

AD-A159 982

CONSTRUCTION AND CALIBRATION OF THE OTTAUQUECHEE RIVER
MODEL(U) COLD REGIONS RESEARCH AND ENGINEERING LAB
HANOVER NH G GOOCH AUG 85 CRREL-SR-85-13

1/1

UNCLASSIFIED

F/G 8/8

NL



END
FILED
DTC

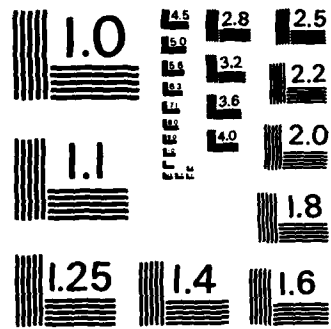

MICROCOPY RESOLUTION TEST CHART
NATIONAL BUREAU OF STANDARDS - 1963 - A

Special Report 85-13

August 1985



12

**US Army Corps
of Engineers**

Cold Regions Research &
Engineering Laboratory

Construction and calibration of the Ottawaquechee River model

Gordon Gooch

AD-A159 902

REPRODUCTION COPY

DTIC
ELECTE
OCT 08 1985
S E D

Prepared for
OFFICE OF THE CHIEF OF ENGINEERS

Approved for public release. distribution is unlimited

85 10 7 008

Unclassified

SECURITY CLASSIFICATION OF THIS PAGE (When Data Entered)

REPORT DOCUMENTATION PAGE		READ INSTRUCTIONS BEFORE COMPLETING FORM
1. REPORT NUMBER Special Report 85-13	2. GOVT ACCESSION NO. AD-A159 902	3. RECIPIENT'S CATALOG NUMBER
4. TITLE (and Subtitle) CONSTRUCTION AND CALIBRATION OF THE OTTAUQUECHEE RIVER MODEL		5. TYPE OF REPORT & PERIOD COVERED
		6. PERFORMING ORG. REPORT NUMBER
7. AUTHOR(s) Gordon Gooch		8. CONTRACT OR GRANT NUMBER(s)
9. PERFORMING ORGANIZATION NAME AND ADDRESS U.S. Army Cold Regions Research and Engineering Laboratory Hanover, New Hampshire 03755-1290		10. PROGRAM ELEMENT, PROJECT, TASK AREA & WORK UNIT NUMBERS CWIS 31357
11. CONTROLLING OFFICE NAME AND ADDRESS Office of the Chief of Engineers Washington, D.C. 20314		12. REPORT DATE August 1985
		13. NUMBER OF PAGES 14
14. MONITORING AGENCY NAME & ADDRESS (if different from Controlling Office)		15. SECURITY CLASS. (of this report) Unclassified
		15a. DECLASSIFICATION/DOWNGRADING SCHEDULE
16. DISTRIBUTION STATEMENT (of this Report) Approved for public release; distribution is unlimited.		
17. DISTRIBUTION STATEMENT (of the abstract entered in Block 20, if different from Report)		
18. SUPPLEMENTARY NOTES		
19. KEY WORDS (Continue on reverse side if necessary and identify by block number) Hydraulic models Ice Ice breakup Ice jams Models		
20. ABSTRACT (Continue on reverse side if necessary and identify by block number) The Ottauquechee River is located in west-central Vermont. This river was chosen for a physical hydraulic model using real ice. The model was built at a scale of 1:50 horizontal and 1:20 vertical. After problems with modeling bed roughness and operating the pump system were overcome, the tests went smoothly.		

PREFACE

This report was prepared by Gordon Gooch, Civil Engineering Technician, Ice Engineering Research Branch, Experimental Engineering Division, U.S. Army Cold Regions Research and Engineering Laboratory. It was technically reviewed by James Wuebben and Dr. Jean-Claude Tatinclaux of CRREL. This work was funded under the U.S. Army Corps of Engineers Civil Works Ice Engineering Program, CWIS 31357, Model Studies of Ice Jam Formation.

Calvin Ackerman, senior model maker for the Ice Engineering Research Branch, CRREL, helped with construction techniques. Instrumentation for monitoring and calibrating the Ottawauechee River model was developed and built by James Morse of the Technical Services Division.

The contents of this report are not to be used for advertising or promotional purposes. Citation of brand names does not constitute an official endorsement or approval of the use of such commercial products.

CONVERSION FACTORS: U.S. CUSTOMARY TO METRIC (SI) UNITS OF MEASUREMENT

These conversion factors include all the significant digits given in the conversion tables in the ASTM Metric Practic Guide (E 380), which has been approved for use by the Department of Defense. Converted values should be rounded to have the same precision as the original (see E 380).

Multiply	By	To obtain
foot	0.3048*	meter
gallon	0.003785412	meter ³
horsepower	745.6999	watt
inch	0.0254*	meter
mile	1609.344*	meter
lbf/in ² (psi)	6894.757	pascal
ton	907.1847	kilogram

*Exact

Accession For	
NTIS GRA&I	<input checked="" type="checkbox"/>
DTIC TAB	<input type="checkbox"/>
Unannounced	<input type="checkbox"/>
Justification	
By _____	
Distribution/	
Availability Codes	
Dist	Avail and/or Special
A-1	



CONSTRUCTION AND CALIBRATION
OF THE
OTTAUQUECHEE RIVER MODEL

Gordon Gooch

INTRODUCTION

A model of a 1.5-mile section of the Ottauquechee River in Quechee, Vermont, was built in the Ice Engineering Facility at CRREL to study the complex processes of ice formation, progression and break-up and ice jam flooding. The model scale was 1:50 horizontal and 1:20 vertical. This report outlines the methods and materials used for construction and calibration. Also mentioned in this report are some of the problems encountered while testing in a cold environment.

We began building the model in July 1980 and finished in January 1981. When the model calibration was complete in October 1981, experiments began. Results of these tests will be given in a future report.

FIELD DATA

During the summers of 1975-1979, a survey team ran a series of closed-loop traverses and took cross sections of the Ottauquechee River bed over a two-mile reach at intervals of 200 ft. The topography of the surrounding flood plain was determined by aerial photography using a series of check-point elevations to establish true horizontal and vertical control. The river survey and the aerial photography were used to prepare a 1:50-scale contour map of the riverbed and flood plain. We used the coordinate grid system from the contour map to lay out a working base line for building the model. This base line was used to transfer all the horizontal and vertical ground elevation detail for layout.

CONSTRUCTION

Building lines were marked out to orient the model. Cement block walls were built around the perimeter to contain the sand fill that would serve as a base for the river model (Fig. 1). Inside the wall perimeter the base line was marked off at 4-ft intervals. At 90° to the base line, a series of parallel lines were laid out to position plywood sheets, which were held vertical and on which elevations were marked. After all details

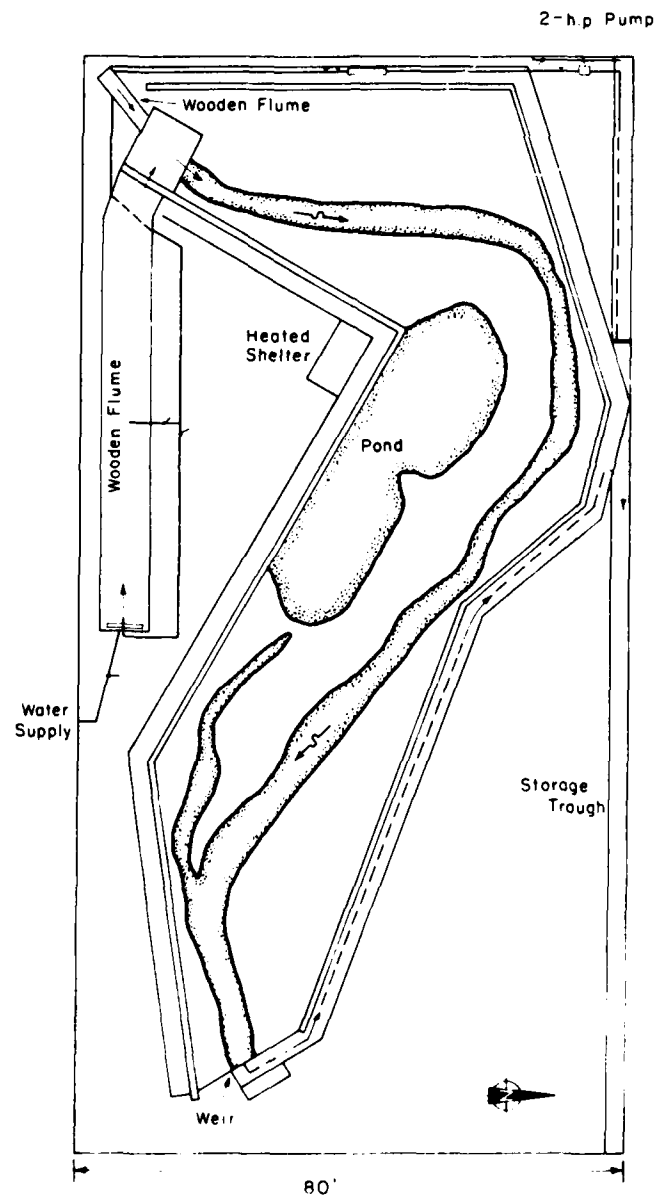

Figure 1. Layout of the model.

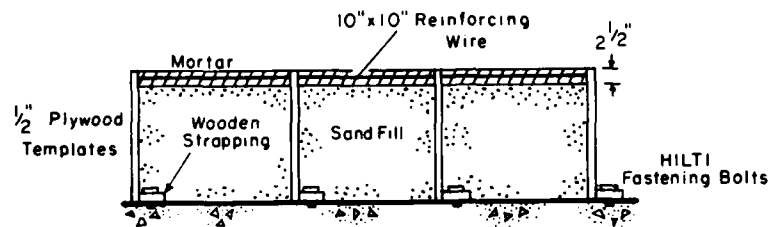

Figure 2. Model construction method.

were marked, templates were cut and fastened securely. The templates marked the approximate topography for subsequent model construction.

The next task was to fill the void between the floor and the finish grade of the model surface (Fig. 2). All but the last 2-1/2 in. was filled with clean plaster sand. A mortar mix was used for the surface of the river model, with the top of each template section serving as a guide for the finish surface contours.

When the mortar surface was dry and clean, we applied three coats of fiberglass resin to waterproof the surface. This system did not hold up as well as expected, possibly due to the freezing, thawing and moisture penetration. There was a great deal of scaling, separating the fiberglass and paint from the mortar. In time most of the surface had scaled, exposing the mortar, which could have been damaged further. We cleaned the surface thoroughly and applied epoxy paint.

Along both banks of the river, heat tapes were installed. By heating the banks any ice buildup could be released. Two major problems were encountered: the tapes moved when the mortar was poured and there were short circuits in the tapes. A heat-sensitive camera was used to trace and mark the location of the heat tapes.

Three areas of the model were outlined in different colors: the river, the flood plain and those areas above the 200-year flood plain elevation. Starting at the outflow of the model, the riverbed was numbered every four feet for documentation during experiments.

MODELING BED ROUGHNESS

One of the most time consuming tasks was modeling the riverbed roughness. Because the mortar surface was very smooth, the water surface elevations in the model were lower than in the actual river.

To increase the roughness, metal tabs were fastened to the riverbed. Each tab measured $3/4$ in. x $1-1/2$ in. A 90° bend was made so that $3/4$ in. of each tab stood vertically. The tabs were placed in rows spaced 6-12 in. apart depending on the amount of roughness needed. With each arrangement, calibration flows were used to test the effect. By increasing or decreasing the number of tabs in a given area, we could adjust the water levels to match the water surface elevations of the river.

After the open water calibration tests were complete, freeze-up tests began. In the first test the metal tabs became clogged with ice and gave unreasonably high water levels. We removed the tabs and replaced them with plastic fencing material with 1.5-in.-square openings laid flat on the bottom. Each roll was 50 ft long and 3 ft wide and was easily fastened in place and trimmed to fit existing contours. This material worked very well and did not have the ice build-up problem.

WATER SUPPLY SYSTEM

The model had two water pump systems, a small Bell and Gossett, 2-h.p. centrifugal pump with a maximum output of 200 gal/min at 22 ft head, and a larger pump with a 10-h.p. motor with a maximum output of 450 gal./min. The pumps could be used separately or together depending on the desired flow. During freeze-up tests and low-flow conditions, the small pump system was used, and during simulated ice jam tests both pumps were needed.

The small pump drew its water from a 2.2- x 3.5- x 160-ft storage trough located on the north side of the research area. Water passed

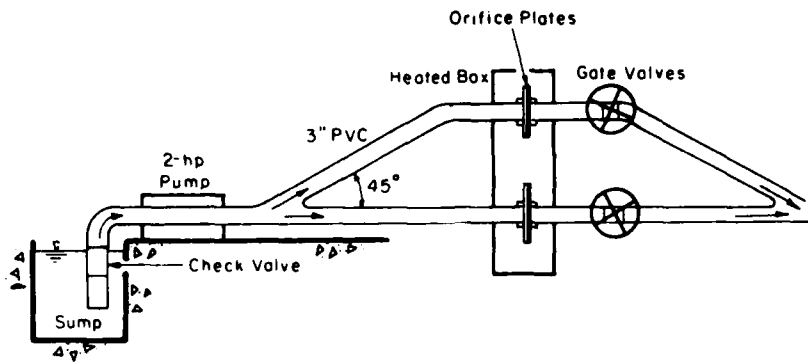

Figure 3. Low-flow water supply system.

through a 3-in. PVC pipe to a point 23 ft from the pump, where it forked into two lines, each controlled by a gate valve (Fig. 3). To measure the amount of flow to the model, each water line had an aluminum orifice plate bolted between two flange connections. These plates were 1/8 in. thick with an outside diameter of 7-1/2 in. and inside diameters of 2.332 in. and 1.595 in. Air bleeder valves on each side of the flange allow trapped air to escape. Pressure taps on each side of the orifice plates allowed the differential pressure to be monitored by a transducer. This system accurately indicated the amount of water passing through the system. The instrumentation was inclosed in a temperature-controlled shelter.

We calibrated the two pumps by measuring the volume of water drawn from the water storage trough over a measured time and comparing this with the values set on the pump control. For the small pump the flow corresponding to a set pressure differential at the orifice plate was used. Based on the amount of water level drop, the volume was computed and compared to that of the pump curve. The measured values were within 1-5 gal./min of the values calculated, depending on the flow used. For the larger pump system the same technique was used but the water level rise as the pump discharged into the trough was monitored at 150 gal./min; the flow set

on the instrumentation console was within 3 gal./min of the measured value.

The flow continued along the west side of the room, where it was directed to one of two wooden flumes (Fig. 1). The smaller flume consisted of a wooden rectangular box with a 3-in. supply line feeding into it and overflowing onto a wooden ramp with a slope of 16% and a length of 10 ft. It then emptied into a 7- x 8- x 2.7-ft rectangular box before entering the model. The larger ice storage flume measured 7 x 60 x 1 ft high and had a 3-in. and a 6-in. water supply line. An adjustable weir regulated the water depth. All wooden surfaces in contact with the water were coated with fiberglass resin. The larger flume had a slope of 0.4% and discharged into the same rectangular box as the smaller flume. The 6-in. water line drew water from a 60,000 gal. tank located in the basement.

During ice production experiments, ice built up at the inlet of the model. Due to the depth and low velocities, a solid ice sheet would form, stopping frazil ice from entering the model. To solve this problem we installed an air bubbler to create a flow pattern that would direct the ice into the model. This system consisted of a plastic air line with holes drilled at regular intervals. The air line was placed at the bottom of the head box around the perimeter and held in place by lead weights. Air was supplied by a small portable compressor at 30 psi.

A sharp-crested weir controlled the water surface elevation in the backwater area of the model. The weir was made of aluminum and moved vertically, maintaining a watertight seal and remaining level at all times (Fig. 4). To adjust the elevation of the weir, two 1/4-ton, Duff Norton screw jacks were attached on either side and above the weir with a connecting bar and crank. A point gauge was attached at one end of the weir for accurate vertical measurements.

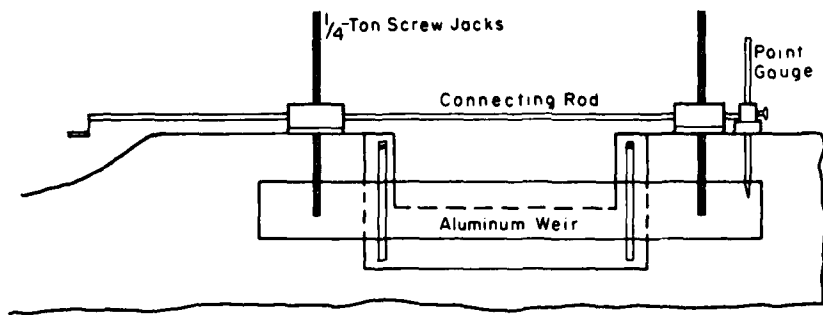

Figure 4. Sharp-crested weir.

INSTRUMENTATION

Nine water level standpipes were laid out from the riverbed locations through the block walls to an enclosed shelter. Each standpipe was connected to a pressure transducer, which measured the fluctuating water level (Fig. 5). The signal from the transducer was stored on an HP 9845 computer. A sliding point gauge was mounted above the standpipes, and each water level change could be checked against the computer output data. The 1.5-in. PVC pipe was insulated with fiberglass and wrapped with a heat tape to prevent freezing. The entire data collection system was enclosed in a heated shelter (Fig. 1).

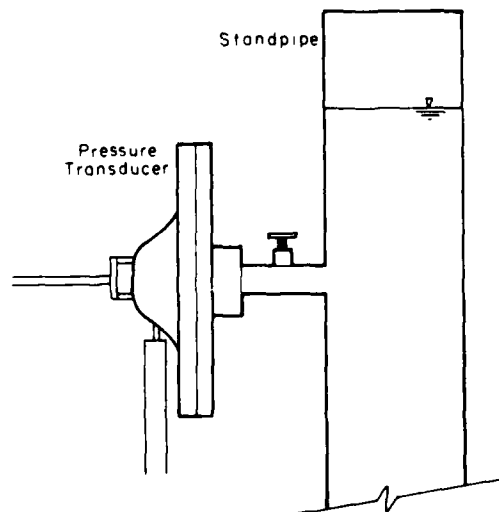

Figure 5. Device for measuring the water level.

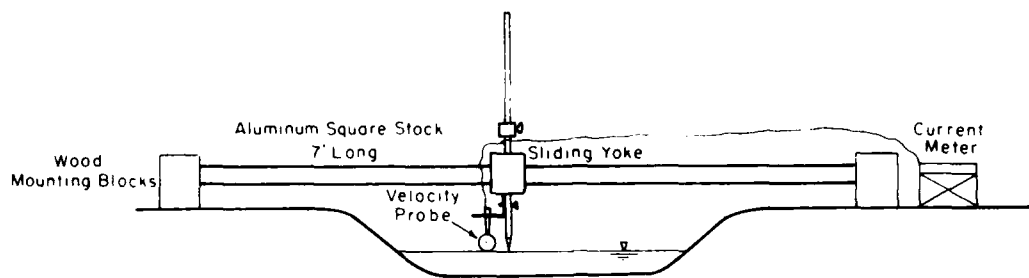

Figure 6. Device for measuring the flow velocity.

To measure the velocity at specific locations, we used a square aluminum bar with a sliding yoke and point gauge with a March McBirney velocity probe (Fig. 6). At each site where a profile was needed, a set of wooden blocks was attached to the model surface. The aluminum bar could then be slipped between the blocks to hold the probe in position for the velocity profile.

Thermistors were used to monitor the air and water temperatures to within 0.02°C . They were placed at all water level measuring locations and also at the inlet and the outlet of the model. Their measurements were fed into the computer system, and temperature fluctuations and water level changes were computed. An ice bath was used to check the thermistors before each series of tests. The ice bath consisted of crushed ice packed tightly into a vacuum bottle with a hole made in the center and a small amount of distilled water added. With a properly made ice bath, a thermistor will read a constant 0°C . Fluctuations can be caused when moisture penetrates wire splices or when the glass covering on the thermistor is damaged.

Thermocouples placed in the sand below the model surface measured the temperature changes as the room was being cooled. Three locations were chosen and various depths at each site were monitored on a digital thermocouple reader.

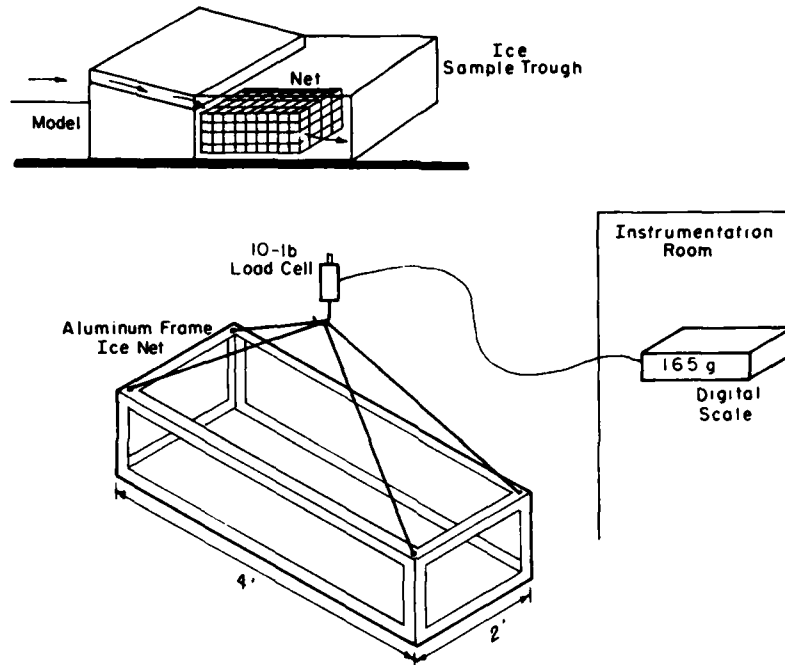

Figure 7. Device for sampling the ice discharge.

At the outlet of the model an ice discharge sampler was constructed (Fig. 7). The sampler consisted of an aluminum frame with fiberglass screening that filtered out the smaller particles. After a measured time, the ice was allowed to drain and was weighed. A 10-lb load cell suspended above the sample trough was used to measure the weight to the nearest gram. The water returned to the water storage trough, completing the closed loop water system.

After a few days of testing, ice could replace most of the water storage and cause the water level at the pump intake to drop to a point where additional water had to be added. One solution to this problem was to turn on the trough heating system for 2-3 hours after a day of testing. This melted the ice without warming the water enough to delay the experiments for the next day. Baffle boards in the storage trough helped prevent ice from reaching the pump intake. Also, the second pump could add water

through a 6-in. line at the west end of the storage trough. The temperature of this water system could be regulated from an ice builder coil or from a heat exchanger system located inside the water storage tank in the basement.

CONCLUSIONS

Construction went smoothly due to the experience and hard work of those involved. Calibration required a few variations of materials and concepts to establish the proper bed roughness. The two water supply pumps were difficult to use simultaneously, requiring additional personnel to control the flow. After temperature schedules and testing procedures were established, model operation became routine. Future model studies will benefit from the experience in construction and testing techniques developed.

END

FILMED

11-85

DTIC