

AD-A161 037

NONLINEAR ACOUSTICS: LONG RANGE UNDERWATER PROPAGATION
AIR-FILLED POROUS (U) TEXAS UNIV AT AUSTIN APPLIED
RESEARCH LABS D T BLACKSTOCK 28 OCT 85 ARL-TR-85-36
N00014-84-K-0574

1/1

UNCLASSIFIED

F/G 20/1

NL



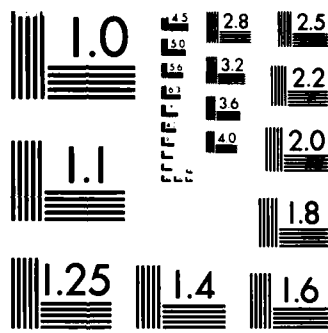

MICROCOPY RESOLUTION TEST CHART
NATIONAL BUREAU OF STANDARDS-1963-A

ARL-TR-85-36

Copy No. 12

12

**NONLINEAR ACOUSTICS: LONG RANGE UNDERWATER PROPAGATION,
AIR-FILLED POROUS MATERIALS, AND NONCOLLINEAR
INTERACTION IN A WAVEGUIDE**
FIRST ANNUAL SUMMARY REPORT UNDER CONTRACT N00014-84-K-0574

David T. Blackstock

APPLIED RESEARCH LABORATORIES
THE UNIVERSITY OF TEXAS AT AUSTIN
POST OFFICE BOX 8029, AUSTIN, TEXAS 78713-8029

AD-A161 037

28 October 1985

Technical Report

1 August 1984 - 31 October 1985

APPROVED FOR PUBLIC RELEASE;
DISTRIBUTION UNLIMITED.

Prepared for:

**OFFICE OF NAVAL RESEARCH
DEPARTMENT OF THE NAVY
ARLINGTON, VA 22217**

DTIC FILE COPY



DTIC
ELECTE
NOV 8 1985
S
A

85 11 08 00 5

I. INTRODUCTION

Contract N00014-K-0574, which began 1 August 1984, provides for basic research on nonlinear acoustics. The contract is the successor to Contract N00014-75-C-0867 (ended 31 August 1984) and also continues research begun under Contract N00014-82-K-0805 (ended 30 November 1984) on the specific topic of nonlinear effects in long range underwater propagation. The period of this report is 1 August 1984 - 31 October 1985. However, because much of the current work began under the previous two contracts, for clarity this report covers some of the work done prior to the present contract. The basic objective of the research is to investigate the behavior of finite-amplitude sound, in particular to investigate effects that do not occur in small-signal sound fields.

The personnel involved in the research are as follows.

Senior personnel

D. T. Blackstock, principal investigator

R. Buckley, consultant. Institute of Sound and Vibration Research (ISVR), University of Southampton, UK.

C. L. Morfey, consultant, ISVR, University of Southampton, UK.

W. M. Wright, consultant, Physics Dept., Kalamazoo College, Kalamazoo, MI.

Postdoctoral fellow

M. F. Hamilton, Ph.D., Pennsylvania State University (1983).

Graduate students

F. D. Cotaras, M.S. student in Electrical Engineering. Completed M.S. degree August 1985; Ph.D. student beginning September 1985.

D. A. Nelson, M.S. student in Mechanical Engineering. Completed M.S. degree December 1985.

J. A. TenCate, Ph.D. student in Mechanical Engineering.

II. PROJECTS

1. Nonlinear effects in long range underwater propagation (Cotaras, Morfey, and Buckley). This work began under Contract N00014-82-K-0805. The research was started by C. L. Morfey, who was at ARL:UT on leave from ISVR during the first six months of 1983. Assisting as a consultant was Richard Buckley, also of ISVR, who functioned primarily under the direction of Morfey. After Morfey returned to ISVR in July 1983, he continued the research, at a much reduced level of effort, as a consultant to ARL:UT. In September 1983, F. D. Cotaras, at ARL:UT on educational leave from DREA in Canada, began work on the project for a master's degree. A brief description of the work done prior to 1 August 1984 will be followed by a report of progress since that date.

Scientists and engineers working on problems in long range underwater propagation depend almost entirely on linear acoustical theory. They recognize that in order to produce signals that travel great distances the source may have to generate a sound of finite amplitude. They assume, however, that after the signal has propagated a certain range, say one hundred or a few hundred meters, the amplitude will have decreased to the point that nonlinear effects are no longer important. Our research was guided by two questions. (1) Is there really a range beyond which nonlinearity may be ignored? (Certain evidence pointed to a negative answer to this question.^{1,2}) (2) If such a range does exist, what is its magnitude and on what does it depend?

¹ H. W. Marsh, R. H. Mellen, and W. L. Konrad, "Anomalous absorption of pressure waves from explosions in sea water," J. Acoust. Soc. Am. 38, 326-328 (1965).

² D. A. Webster and D. T. Blackstock, "Experimental investigation of outdoor propagation of finite-amplitude noise," NASA Contractor Report 2992, Applied Research Laboratories, The University of Texas at Austin (August 1978) (N78-31876).

The three linear theories most commonly used in long range propagation studies are ray theory, the parabolic approximation, and normal mode theory. For three reasons we selected ray theory for our work. First, ray theory is simple and versatile. Second, much was known about how to extend ray theory to cover finite-amplitude waves. Third, the prospects for analytical solutions in certain cases were good.

When Morfey began the research, he divided it into three tasks.

- I. Shock pulse propagation in a homogeneous ocean. The intent here was to develop a computer program to calculate the propagation of sound from realistic explosions in a homogeneous but otherwise realistic ocean. In other words, we wished to implement weak shock theory for spherical waves in a relaxing, viscous fluid.
- II. Nonlinear propagation in a depth dependent ocean. Shocks and dissipation were ignored in this task. Of primary interest was the effect of inhomogeneity on nonlinear distortion. An analytical model based on nonlinear geometrical acoustics was to be developed.
- III. Nonlinear propagation in a caustic region. This topic, which required special attention because of the confluence of three effects -- nonlinear distortion, focusing, and diffraction -- was assigned to consultant Richard Buckley.

The overall plan was to work on each of the three tasks separately and, when they were completed, to put the results all together, probably in the form of a single computer program. One would then be able to calculate the propagation of an intense underwater signal over great distances, under a variety of conditions.

Starting from where Morfey left off on Tasks I and II, Cotaras carried out further work on the two tasks as needed and combined the results. In retrospect this was not a small order, despite the fact that Morfey had in one sense nearly completed Task II.³

During the period covered by this report Cotaras accomplished four things. First, he completed all the analytical work to show how the equations of nonlinear geometrical acoustics are derived from the general equations of fluid mechanics for an inhomogeneous medium. Second, he completed the computer program (which had been started by Morfey) by which propagation calculations based on nonlinear geometrical acoustics are carried out. The program represents a merger of Tasks I and II. He tested the program by running it for cases for which analytical results are known. Third, he applied the program to two different source signals (explosions) of interest. A parametric study of propagation up to 57 km was performed. An interim report was given at the Fall 1984 Acoustical Society of America (ASA) Meeting in Minneapolis (84-4).⁴ One of the unique features of the program is the option available to the operator of turning off nonlinear effects beyond a given range. This option was very useful in helping to answer the question with which we began this project: Beyond what range is it safe to ignore nonlinear effects? The answer is not simple, but we did learn that the "cutoff range" increases with the frequency band in which one is interested. Finally, Cotaras wrote his thesis (85-7), the abstract of which is quoted here.

"In this thesis the propagation of finite amplitude acoustic signals through an inhomogeneous ocean is investigated both analytically and numerically. The effects of reflections and focusing are not considered.

³ C. L. Morfey "Nonlinear Propagation in a Depth-Dependent Ocean," Technical Report ARL-TR-84-11, Applied Research Laboratories, The University of Texas at Austin, 1 May 1984 (ADA 145 079).

⁴ Numbers given in this style refer to items in the Chronological Bibliography, e.g., 84-4 means the fourth entry in the list for 1984.

From simplified versions of the lossless hydrodynamics equations the theories of linear and nonlinear geometrical acoustics are developed. Losses are accounted for directly in the numerical routine. The eikonal equation, from which an equation for the ray paths is derived, is assumed to be the same for both small-signal and finite amplitude waves. The transport equation is found to be different, however. The transport equation leads to a standard first-order progressive wave equation, linear for small-signal waves, but nonlinear for finite amplitude waves. All the analysis is carried out in the time domain and is for a fully inhomogeneous ocean.

"In the numerical study the ocean is assumed to be stratified. The effects of inhomogeneity, ordinary attenuation and dispersion, and nonlinear propagation are investigated using a numerical implementation of nonlinear geometrical acoustics. Two explosion waveforms are considered: a weak shock with an exponentially decaying tail and a more realistic waveform that includes the first bubble pulse. Numerical propagation of the simpler wave along a 58.1 km path starting at a depth of 300 m leads to the following conclusions: (1) The effect of inhomogeneity on nonlinear distortion is small. (2) Dispersion plays an important role in determining the arrival time of the pulse. (3) Neither nonlinearity nor ordinary attenuation (and dispersion) are paramount; both need to be included. For the more realistic wave the propagation is along a 23 km ray path starting from a depth of 4300 m. Two charge weights, 0.818 kg and 22.7 kg TNT, are used. In each case the energy spectrum of the signal obtained by considering finite amplitude effects for the entire 23 km path is compared with spectra obtained by neglecting finite amplitude effects (1) entirely, (2) after the first 150 m, and (3) after the first 1100 m. Finite amplitude effects are found to be of small consequence in the case of the 0.818 kg TNT explosion for frequencies below 6 kHz at distances beyond 1100 m. For the 22.7 kg explosion the corresponding quantities are 4 kHz and 1100 m."

Morfev and, to a lesser extent, Buckley have continued their work on the project as consultants. Most of the effort has been toward writing

journal articles on work that has been accomplished. In November 1984 Buckley submitted a manuscript on his work on caustics to the Journal of the Acoustical Society of America. As a result of comments by reviewers, he now plans to divide the manuscript into two articles, one on the time-domain, linear theory of caustics and the other on nonlinear theory. A paper on the latter was given at the Spring 1985 ASA Meeting in Austin (85-3). Morfey is also working on or has plans for two journal articles. One article is based on his Task I results, which were reported partly at the Kobe International Symposium on Nonlinear Acoustics (ISNA)⁵ and more recently at the Austin ASA Meeting (85-2). The second article will be based on his technical report.³

2. Nonlinear effects in air-filled, bulk porous materials (Nelson). This work began in 1978 under NASA Grant NSG 3198. The first phase was completed in 1982,⁶ at which time Nelson began working on the problem. The project continued to receive its main support from the NASA grant until its expiration 28 February 1985. Nelson completed his thesis in December 1984 (84-9), which, with an added chapter on lined ducts, became a technical report (85-1). The following is the abstract from the report.

"The subject of this investigation is the propagation of high intensity sound waves through an air-filled porous material. The material is assumed (1) to be rigid, incompressible, and homogeneous, and (2) to be adequately described by two properties: resistivity r and porosity Ω . The

⁵ C. L. Morfey, "Aperiodic signal propagation at finite amplitude: some practical applications," 10th International Symposium on Nonlinear Acoustics, Kobe, Japan, 24-28 July 1984.

⁶ H. L. Kuntz, "High-intensity sound in air saturated fibrous bulk porous materials," Ph.D. dissertation, The University of Texas at Austin. Also issued under the same name as Technical Report ARL-TR-82-54, Applied Research Laboratories, The University of Texas at Austin (3 September 1982) (ADA 121 450).

resistivity was measured as a function of velocity for static flows and found to follow the empirical relation $r=r_1+r_2 u \operatorname{sgn}(u)$. This relation is assumed to apply for acoustic signals as well. Ordinary hydrodynamic nonlinearity (which leads to shock formation) is neglected because of the very high attenuation in the porous material. The resulting wave equation is still nonlinear, however, because of the $u \operatorname{sgn}(u)$ term in the resistivity. The equation is solved in the frequency domain as an infinite set of coupled inhomogeneous Helmholtz equations, one for each harmonic. An approximate first integral formulation of these equations gives relations for progressive waves. The source wave considered is a slightly distorted intense tone, that is, a finite-amplitude fundamental accompanied by weak higher harmonics. An approximate but analytical solution leads to predictions of excess attenuation, saturation, and phase speed reduction for the fundamental component. A more general numerical solution is used to calculate the propagation curves for the higher harmonics. The $u \operatorname{sgn}(u)$ nonlinearity produces a cubic distortion pattern; when the input signal is a pure tone, only odd harmonic distortion products are generated. Quantitative experiments were performed on batted Kevlar[®] 29 having porosities in the range $\Omega=0.94$ to 0.98 . Measurements were taken in the 400 to 6200 Hz frequency range for small-signal waves, 500-1500 Hz for finite-amplitude waves. Source levels for the finite-amplitude waves extended to 160 dB. Qualitative confirmation of predictions has been obtained in all cases, and quantitative confirmation in most cases. The theory is then applied to the problem of propagation and attenuation in lined ducts. A vector version of the wave equation is derived along with the corresponding inhomogeneous Helmholtz equations. These are used as the basis of a perturbation solution for reflection from a porous half-space and propagation in lined ducts. The solution becomes extremely complicated, however, when used for high intensity waves in lined ducts. An ad hoc model is therefore presented for the purpose of illustrating the gross nonlinear effects on absorption."

A report on the later stages of the work was given at the Spring 1985 ASA Meeting in Austin (85-4).

3. Nonlinear interaction in a rectangular waveguide. (Hamilton and TenCate). This work is an outgrowth of Hamilton's Ph.D. research (84-6,7) and TenCate's M.S. research (84-2). Experiments and theoretical calculations were carried out for two different excitations of the waveguide, referred to here for convenience as Cases A and B. In Case A a source launches a monochromatic wave called the fundamental (of frequency f) that travels down the waveguide in the 1,0 mode. The discussion that follows may most easily be described in terms of small-signal concepts. In the 1,0 mode the wave bounces back and forth between the top and bottom walls of the waveguide as shown in Fig. 1 (the 0,0 mode is also shown; it plays no role in Case A). The angle the wave makes with the waveguide

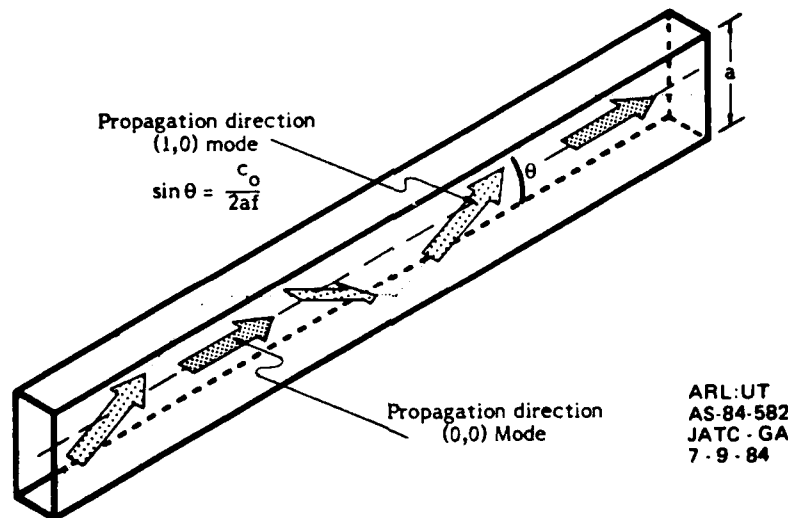
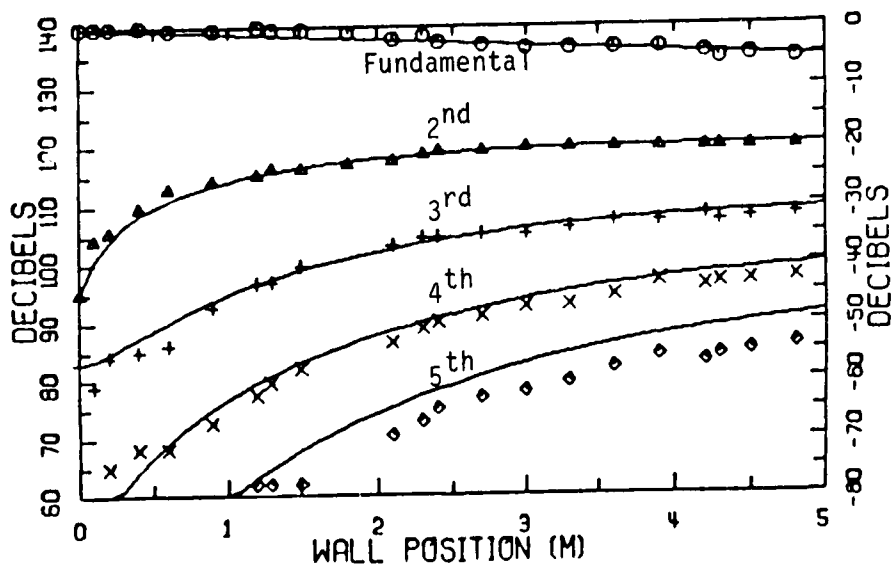

Fig. 1. Propagation in the 0,0 and 1,0 modes of a rectangular waveguide (f = frequency, c_0 = small-signal sound speed, a = height of the guide).

axis is given by the formula in the figure. As the frequency is lowered toward cutoff, θ approaches 90° . Far above cutoff on the other hand, θ approaches 0° . The bouncing wave may be decomposed into upward and downward traveling waves that make angles $+\theta$ and $-\theta$, respectively, with the waveguide axis. Now, when the wave is of finite amplitude, it generates a family of harmonic distortion components. Resonant or synchronous

interaction (like that which takes place when a plane wave propagates in an open medium) occurs when all the harmonics in the family travel at the same speed and in the same direction. This happens when the second harmonic travels in the 2,0 mode, the third harmonic in the 3,0 mode, and so on. The angle θ is then the same for all members of the family (all members have the same group velocity). It turns out that the analysis is simplest when the frequency is such that θ is in the middle range, that is, neither close to cutoff nor close to high frequency operation. In this range the upward and downward traveling waves do not have much effect on each other. Near cutoff ($\theta \rightarrow 90^\circ$) the standing wave nature of the field becomes important and the interaction between the upward and downward waves cannot be ignored. At high frequency ($\theta \rightarrow 0^\circ$) the two waves begin to reinforce each other strongly. Theory and data for a middle range experiment is shown in Fig. 2. Boundary layer losses at the tube walls have been accounted for. It is seen that the theoretical predictions are borne out by the measurements. This work was reported at the Austin ASA Meeting (85-5).



AS-85-986

Fig. 2. Computed and measured propagation curves for the fundamental and second-fifth harmonic distortion components in a rectangular waveguide. The mode for the fundamental is 1,0, the frequency is 3000 Hz, and the angle θ is 55.2° . The cutoff frequency for this waveguide is 2464 Hz.

In Case B two tones interact, one a low frequency wave in the 0,0 mode, the other a high frequency wave in the 1,0 mode (see Fig. 1). The distortion components of chief interest in this case are the sum and difference frequency waves. Dispersion causes a scalloped pattern in the amplitude versus distance curves. The results, both theoretical and experimental, shed light on some of the questions raised by TenCate's thesis (84-2), for example, the dependence of the coefficient of nonlinearity β on the angle θ at which the two tones interact. Some of this work was reported at the Austin ASA Meeting (85-5). More will be reported at the Fall 1985 ASA Meeting in Nashville (85-8), and a journal article is in preparation (85-9).

4. Miscellaneous. A paper by Blackstock on a generalized Burgers equation was published in the Journal of the Acoustical Society of America (85-6). This work had been reported orally earlier.⁷ An oral paper on a topic in the history of nonlinear acoustics was given at the Fall 1984 Meeting of the Texas Section of the American Association of Physics Teachers in Houston (84-8). Two earlier articles on nonlinear acoustics were reprinted in Nonlinear Acoustics in Fluids, the final volume in the series Benchmark Papers in Acoustics (84-10 and 84-11). A journal article by Wright on excitation of a cylindrical cavity by a line thermoacoustic source is in preparation (85-10).

Two new projects were just underway as the report period ended, both Ph.D. dissertation research topics. TenCate has begun work on an acoustical chaos experiment, intense standing waves in a closed tube. His initial task is to search for subharmonics in the response of the tube when it is driven in a higher order longitudinal mode. For his dissertation topic, Cotaras has chosen nonlinear effects in refraction and transmission of sound incident obliquely at an interface between two media, for example, the ocean-sediment interface. At this point only a literature survey has been started.

⁷ D.T. Blackstock, "Generalized Burgers equation for plane waves," 9th International Symposium on Nonlinear Acoustics, 20-24 July 1981, Leeds, England.

CHRONOLOGICAL BIBLIOGRAPHY

1984-1985

Contract N00014-84-K-0574

and

Predecessor Contract N00014-75-C-0867

Code	ONR CONTRACTS
B = chapter in a book	0574 means N00014-84-K-0574, began 8-1-84
J = journal publication	
JS = submitted for journal publication	0867 means N00014-75-C-0867, ended 8-31-84
O = oral presentation	0805 means N00014-82-K-0805
P = paper in a proceedings	
T = thesis or dissertation	
TR = technical report	

1984

ONR Contract	Code	
0867	O,P	1. S. Saito and T. G. Muir, "Simple model for analyzing a parametric focusing source," meeting of the Acoustical Society of Japan, 29-31 March 1984, Tokyo, Japan, Proceedings, pp. 33-40 (in Japanese).
0867	TR	2. J. A. TenCate, "Nonlinear interaction of two noncollinear sound waves in a rectangular waveguide," Technical Report ARL-TR-84-16, Applied Research Laboratories, The University of Texas at Austin, June 1984 (ADA 144 440).
0867	O,P	3. S. Saito and T. G. Muir, "Second harmonic component in a finite-amplitude sound focusing system, 10th International Symposium on Nonlinear Acoustics, Kobe, Japan, 24-28 July 1984, Proceedings, pp. 129-132.
0805 0574	O	4. F. D. Cotaras, C. L. Morfey, and D. T. Blackstock, "Nonlinear effects in long range underwater propagation," Paper Q6, 108th Meeting, Acoustical Society of America, Minneapolis, MN, 8-12 October 1984, [J. Acoust. Soc. Am. <u>76</u> , S39(A) (1984)].

<u>ONR Contract</u>	<u>Code</u>	
0867	JS	5. D. T. Blackstock, "Generalized Burgers equation for plane waves," submitted 1 November 1984 for publication in J. Acoust. Soc. Am. (see 85-6).
0867	J	*6. M. F. Hamilton and F. H. Fenlon, "Parametric acoustic array formation in dispersive fluids," J. Acoust. Soc. Am. <u>76</u> , 1474-1492 (1984).
0867	J	*7. M. F. Hamilton, "Effects of noncollinear interaction on the parametric acoustic array," J. Acoust. Soc. Am. <u>76</u> , 1493-1504 (1984).
0867 0574	O	8. D. T. Blackstock, "Unusual observations during speed of sound experiments in the Arctic in the 1820's and their effect on the development of nonlinear acoustics," Paper B6, 31st Meeting, Texas Section of American Association of Physics Teachers, San Jacinto College North, Houston, TX, 15-17 November 1984.
0867 0574	T,TR	**9. D. A. Nelson, "Propagation of finite-amplitude sound in air-filled porous materials," MS thesis, Mechanical Engineering Department, The University of Texas at Austin, December 1984.
N/A	B	10. D. T. Blackstock, "Thermoviscous attenuation of plane, periodic, finite-amplitude sound waves," paper No. 14, pp. 207-215, in <u>Nonlinear Acoustics in Fluids</u> , edited by R. T. Beyer (Van Nostrand and Reinhold Co., New York, 1984). Reprinted from J. Acoust. Soc. Am. <u>36</u> , 534-542 (1964).
0867	B	11. D. A. Webster and D. T. Blackstock, "Finite-amplitude saturation of plane sound waves in air," Paper No. 31, pp. 364-369, in <u>Nonlinear Acoustics in Fluids</u> , edited by R. T. Beyer (Van Nostrand and Reinhold Co., New York, 1984). Reprinted from J. Acoust. Soc. Am. <u>62</u> , 518-523 (1977).

* Primary support for this work came from ONR Contract N00014-79-C-0624 with Pennsylvania State University.

** Primary support for this work came from NASA Grant NSG 3198.

1985

<u>ONR Contract</u>	<u>Code</u>	
0867 0574	TR	**1. D. A. Nelson, "Interaction of finite-amplitude sound with air-filled porous materials," Technical Report ARL-TR-85-15, Applied Research Laboratories, March 1985 (ADA 155 986).
0805 0574	O	2. C. L. Morfey and J. M. Estes, "Long-range nonlinear propagation of explosive waveforms in the ocean," Paper M10, 109th Meeting, Acoustical Society of America, Austin, 8-12 April 1985. J. Acoust. Soc. Am. <u>77</u> , S30(A) (1985).
0805 0574	O	3. R. Buckley, "Time domain approach to the propagation of nonlinear acoustic pulses near caustics," Paper M12, 109th Meeting, Acoustical Society of America, Austin, 8-12 April 1985. J. Acoust. Soc. Am. <u>77</u> , S30-31(A) (1985).
0867 0574	O	**4. D. A. Nelson and D. T. Blackstock, "Propagation and attenuation of intense tones in air-filled porous materials," Paper V7, 109th Meeting, Acoustical Society of America, Austin, 8-12 April 1985. J. Acoust. Soc. Am. <u>77</u> , S47(A) (1985).
0867 0574	O	5. M. F. Hamilton and J. A. TenCate, "Higher-order finite amplitude modes in a rectangular waveguide," Paper V10, 109th Meeting, Acoustical Society of America, Austin, 8-12 April 1985. J. Acoust. Soc. Am. <u>77</u> , S47(A) (1985).
0867	J	6. D. T. Blackstock, "Generalized Burgers equation for plane waves," J. Acoust. Soc. Am. <u>77</u> , 2050-2053 (1985).
0867 0805 0574	T	7. F. D. Cotaras, "Nonlinear effects in long range underwater acoustic propagation," M.S. thesis, Electrical Engineering Department, The University of Texas at Austin, August 1985. Also to be issued as Technical Report ARL-TR-85-32, Applied Research Laboratories, The University of Texas at Austin (November 1985) (ADA ____).
0574	O	8. M. F. Hamilton and J. A. TenCate, "A coefficient of nonlinearity for noncollinear plane-wave interaction," Paper S1, 110th Meeting, Acoustical Society of America, Nashville, 4-8 November 1985. J. Acoust. Soc. Am. <u>78</u> , S39(A) (1985).
0574	JS	9. M. F. Hamilton and J. A. TenCate, "Sum and difference frequency generation due to noncollinear interaction in rectangular duct," to be submitted to J. Acoust. Soc. Am.
0867 0574	JS	10. W. M. Wright, "Generation of sound within a closed cell by an alternating current in a straight wire," to be submitted to J. Acoust. Soc. Am.

** Primary support for this work came from NASA Grant NSG 3198.

DISTRIBUTION LIST

Copy No.

Copy No.

1 Director
Defense Advanced Research Projects Agency
1400 Wilson Blvd.
Arlington, Virginia 22209
Attn: Technical Library

2 - 3 Office of Naval Research
Physics Division Office (Code 412)
800 North Quincy Street
Arlington, Virginia 2217

4 Office of Naval Research
Director, Technology (Code 200)
800 North Quincy Street
Arlington, Virginia 22217

5 Naval Research Laboratory
Department of the Navy
Washington, DC 20375
Attn: Technical Library

6 Office of the Director of Defense
Research and Engineering
Information Office Library Branch
The Pentagon
Washington, DC 20301

7 - 8 U.S. Army Research Office
Box 1211
Research Triangle Park
North Carolina 27709

9 - 20 Defense Technical Information Center
Cameron Station
Alexandria, Virginia 22314

21 Director, National Bureau of Standards
Washington, DC 20234
Attn: Technical Library

22 Director
U.S. Army Engineering Research
and Development Laboratories
Fort Belvoir, Virginia 22060
Attn: Technical Documents Center

23 ODDR&E Advisory Group on Electron Devices
201 Varick Street
New York, New York 10014

24 Air Force Office of Scientific Research
Department of the Air Force
Bolling AFB, DC 22209

25 Air Force Weapons Laboratory
Kirtland Air Force Base
Albuquerque, New Mexico 87117
Attn: Technical Library

26 Air Force Avionics Laboratory
Air Force Systems Command
Wright-Patterson Air Force Base
Dayton, Ohio 45433
Attn: Technical Library

27 Lawrence Livermore Laboratory
University of California
P.O. Box 808
Livermore, California 94550
Attn: Dr. W. F. Krupke

28 Harry Diamond Laboratories
2800 Powder Mill Road
Adelphi, Maryland 20783
Attn: Technical Library

29 Naval Air Development Center
Johnsville
Warminster, Pennsylvania 18974
Attn: Technical Library

30 Naval Weapons Center
China Lake, California 93555
Attn: Technical Library (Code 753)

31 Naval Underwater Systems Center
New London, Connecticut 06320
Attn: Technical Center

32 Commandant of the Marine Corps
Scientific Advisor (Code RD-1)
Washington, DC 20380

33 Naval Ordnance Station
Indian Head, Maryland 20640
Attn: Technical Library

34 Naval Postgraduate School
Monterey, California 93940
Attn: Technical Library (Code 0212)

35 Naval Missile Center
Point Mugu, California 93010
Attn: Technical Library (Code 5632.2)

36 Naval Ordnance Station
Louisville, Kentucky 40214
Attn: Technical Library

37 Commanding Officer
Naval Ocean Research & Development Activity
NSTL Station, Mississippi 39529
Attn: Technical Library

38 Naval Explosive Ordnance Disposal Facility
San Diego, California 92152
Attn: Technical Library

39 Naval Ocean Systems Center
San Diego, California 92152
Attn: Technical Library

40 Naval Surface Weapons Center
Silver Spring, Maryland 20910
Attn: Technical Library

41 Naval Ship Research and Development Center
Bethesda, Maryland 20084
Attn: Central Library (Codes L42 and L43)

42 Naval Avionics Facility
Indianapolis, Indiana 46218
Attn: Technical Library

UNCLASSIFIED

SECURITY CLASSIFICATION OF THIS PAGE (When Data Entered)

REPORT DOCUMENTATION PAGE		READ INSTRUCTIONS BEFORE COMPLETING FORM	
1. REPORT NUMBER	2. GOVT ACCESSION NO. <i>AD-A161037</i>	3. RECIPIENT'S CATALOG NUMBER	
4. TITLE (and Subtitle) Nonlinear Acoustics: Long Range Underwater Propagation, Air-filled Porous Materials, and Noncollinear Interaction in a Waveguide. First Annual Summary Report under Contract N00014-84-K-0574		5. TYPE OF REPORT & PERIOD COVERED Annual Summary Report 1 August 1984 - 31 October 1985	
7. AUTHOR(s) David T. Blackstock		6. PERFORMING ORG. REPORT NUMBER ARL-TR-85-36	
9. PERFORMING ORGANIZATION NAME AND ADDRESS Applied Research Laboratories The University of Texas at Austin Austin, Texas 78713-8029		8. CONTRACT OR GRANT NUMBER(s) N00014-84-K-0574	
11. CONTROLLING OFFICE NAME AND ADDRESS Office Naval Research Department of the Navy Arlington, Virginia 22217		10. PROGRAM ELEMENT, PROJECT, TASK AREA & WORK UNIT NUMBERS 61153N 11 RR011-08-01 NR 384-317	
14. MONITORING AGENCY NAME & ADDRESS (if different from Controlling Office)		12. REPORT DATE 28 October 1985	
		13. NUMBER OF PAGES 15	
		15. SECURITY CLASS. (of this report) UNCLASSIFIED	
		15a. DECLASSIFICATION/DOWNGRADING SCHEDULE	
16. DISTRIBUTION STATEMENT (of this Report) Approved for public release; distribution unlimited			
17. DISTRIBUTION STATEMENT (of the abstract entered in Block 20, if different from Report)			
18. SUPPLEMENTARY NOTES <i>CC</i>			
19. KEY WORDS (Continue on reverse side if necessary and identify by block number) nonlinear acoustics, waveform distortion, long range propagation, rectangular waveguide, inhomogeneous fluid, noncollinear interaction, porous materials (airfilled), coefficient of nonlinearity			
20. ABSTRACT (Continue on reverse side if necessary and identify by block number) Research on three topics in nonlinear acoustics is described. (1) <u>Nonlinear effects in long range underwater propagation.</u> The equations of nonlinear geometrical acoustics have been derived from the general equations of fluid mechanics for an inhomogeneous fluid. An analytical solution for the waveform of an arbitrary pressure signal traveling along a ray path has been implemented by a computer program. Not included in the program are effects of reflection and focusing. The program has been run for two types of explosion (continued on back)			

UNCLASSIFIED

SECURITY CLASSIFICATION OF THIS PAGE(When Data Entered)

20. ABSTRACT

waveforms under a variety of conditions. The distance beyond which nonlinear effects may be ignored is found to be frequency dependent. Also included is a separate study on nonlinear effects in a caustic region. (2) Nonlinear effects in air-filled bulk porous materials. Theory and experiments on the propagation of intense airborne sound in bulk porous materials are described. The primary source of nonlinearity is the velocity dependent resistivity of the material. The dependence is such as to cause a "cubic" distortion of the wave; e.g., when the input signal is a pure tone, only odd harmonic distortion components are produced. The fundamental suffers excess attenuation and, at high enough levels, saturation. However, because the impedance increases with sound level, so does the reflectivity. As a result the absorption efficiency of the material to an incident wave in air decreases. (3) Nonlinear interaction in a rectangular waveguide. Two problems are considered, (a) distortion of a wave launched as a single tone in the 1,0 mode of the waveguide, and (b) noncollinear interaction of two noncollinear tones, one a low frequency wave in the 0,0 mode, the other a high frequency wave in the 1,0 mode. The latter problem leads to conclusions about the angular dependence of the coefficient of nonlinearity β . Some miscellaneous projects are also mentioned briefly.



AI



UNCLASSIFIED

SECURITY CLASSIFICATION OF THIS PAGE(When Data Entered)

END

FILMED

12-85

DTIC