

AD-A161 159

COMPUTER TECHNIQUES FOR PRODUCING COLOR MAPS(U) ARMY
ENGINEER WATERWAYS EXPERIMENT STATION VICKSBURG MS
ENVIRONMENTAL LAB A N WILLIAMSON AUG 85
NES/MP/GL-85-13

1/1

UNCLASSIFIED

F/G 8/2

NL

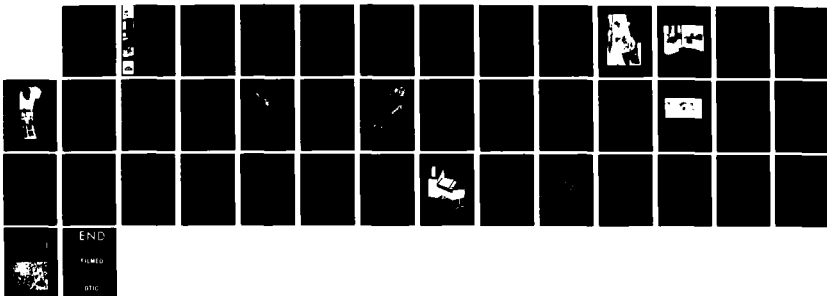

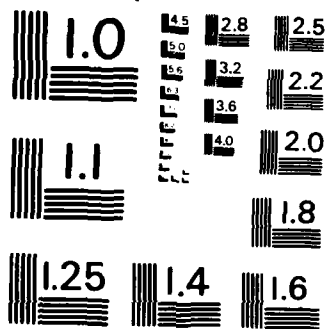

MICROCOPY RESOLUTION TEST CHART
NATIONAL BUREAU OF STANDARDS-1963-A



US Army Corps
of Engineers

AD-A161 159

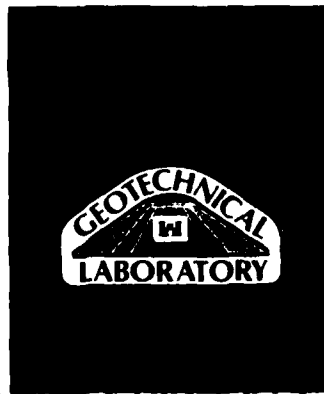

MISCELLANEOUS PAPER GL-85-13

GL

COMPUTER TECHNIQUES FOR PRODUCING COLOR MAPS

by

Albert N. Williamson, Jr.

Geotechnical Laboratory

DEPARTMENT OF THE ARMY
Waterways Experiment Station, Corps of Engineers
PO Box 631, Vicksburg, Mississippi 39180-0631



August 1985
Final Report

Approved For Public Release. Distribution Unlimited

DTIC FILE COPY

Original contains color
plates. All DTIC reproductions
will be in black and
white.

DTIC
SELECTED
NOV 15 1985

SA
A

Prepared for DEPARTMENT OF THE ARMY
US Army Corps of Engineers
Washington, DC 20314-1000

Under Project No. 4A162719AT40,
Task BO, Work Unit 008

88 10 16

Destroy this report when no longer needed. Do not return
it to the originator.

The findings in this report are not to be construed as an official
Department of the Army position unless so designated
by other authorized documents.

The contents of this report are not to be used for
advertising, publication, or promotional purposes.
Citation of trade names does not constitute an
official endorsement or approval of the use of
such commercial products.

Unclassified

SECURITY CLASSIFICATION OF THIS PAGE (When Data Entered)

REPORT DOCUMENTATION PAGE		READ INSTRUCTIONS BEFORE COMPLETING FORM
1. REPORT NUMBER Miscellaneous Paper GL-85-13	2. GOVT ACCESSION NO. AD 7161	3. RECIPIENT'S CATALOG NUMBER 159
4. TITLE (and Subtitle) COMPUTER TECHNIQUES FOR PRODUCING COLOR MAPS	5. TYPE OF REPORT & PERIOD COVERED Final report	
	6. PERFORMING ORG. REPORT NUMBER	
7. AUTHOR(s) Albert N. Williamson, Jr.	8. CONTRACT OR GRANT NUMBER(s)	
9. PERFORMING ORGANIZATION NAME AND ADDRESS US Army Engineer Waterways Experiment Station Geotechnical Laboratory PO Box 631, Vicksburg, Mississippi 39180-0631	10. PROGRAM ELEMENT, PROJECT, TASK AREA & WORK UNIT NUMBERS Project No. 4A162719AT40, Task B0, Work Unit 008	
11. CONTROLLING OFFICE NAME AND ADDRESS DEPARTMENT OF THE ARMY US Army Corps of Engineers Washington, DC 20314-1000	12. REPORT DATE August 1985	
	13. NUMBER OF PAGES 38	
14. MONITORING AGENCY NAME & ADDRESS (if different from Controlling Office)	15. SECURITY CLASS. (of this report) Unclassified	
	15a. DECLASSIFICATION/DOWNGRADING SCHEDULE	
16. DISTRIBUTION STATEMENT (of this Report) Approved for public release; distribution unlimited.		
17. DISTRIBUTION STATEMENT (of the abstract entered in Block 20, if different from Report)		
18. SUPPLEMENTARY NOTES Available from National Technical Information Service, 5285 Port Royal Road, Springfield, Virginia 22161.		
19. KEY WORDS (Continue on reverse side if necessary and identify by block number) Maps--Data processing--Technique (LC) Color in cartography--Technique (LC) Computer graphics--Maps (LC) (LC) Cartography--Automation (LC) Terrain study (Military Science)--Data processing (LC)		
20. ABSTRACT (Continue on reverse side if necessary and identify by block number) This report discusses a technique for encoding maps in a manner that permits rapid production of window maps and color separations. The discussion includes a description of equipment, data processing procedures, and an example of their use for verifying quantitative terrain information for input to an analytical model. A derivation used to portray the output of the Army Mobility Model as a vehicle performance map is described in an appendix.		

PREFACE

This report was originally prepared as a paper for presentation at the US Geological Survey (USGS) International Centennial Symposium held in Reston, Virginia, on 15-17 October 1979. The symposium, entitled "Resources for the Twenty-First Century," was divided into three parts. The first part, sponsored by the USGS, was concerned with the adequacy of energy, mineral, water, and land resources; and with identification, assessment, and development of these resources. The second part, also sponsored by the USGS, was devoted to geologic hazards and their effects on the lives of people; and geologic factors as they affect man and his environment. The third part, sponsored jointly by the USGS and the Commission for the Geologic Map of the World, concentrated on modern cartographic and publication techniques for production of color maps. This report was one of six invited papers presented during the third part of the Symposium.

The work reported herein was conducted by the US Army Engineer Waterways Experiment Station (WES) for the USGS under Order No. ER-66101 during the period September through December 1978. Since presentation of this paper in 1979, additional work, accomplished under RDTE program Project No. 4A162719AT40, Task B0, Work Unit 008, has resulted in adaptation of the data processing procedures discussed herein for portraying mobility-terrain information. An example of the results of this work is presented in Appendix A.

The work reported herein was accomplished by personnel of the Computations and Analysis Group (formerly the Data Handling Branch), Mobility Systems Division, Geotechnical Laboratory, WES, under the general supervision of Mr. J. P. Sale and Dr. W. E. Marcuson, former Chief and Chief, respectively, Geotechnical Laboratory, and Messrs. E. S. Rush and C. J. Nuttall, former Chief and Chief, respectively, Mobility Systems Division. Mr. J. L. Smith, Chief, Computations and Analysis Group, directed the work with the assistance of Mr. A. N. Williamson, Jr. This report was written by Mr. Williamson.

Commanders and Directors of WES during the conduct of this work and preparation of this report were COL John L. Cannon, CE, COL Nelson P. Conover, CE, COL Tilford C. Creel, CE, and COL Robert C. Lee, CE; Technical Director was Mr. Fred R. Brown. Commander of WES at the time of publication was COL Allen F. Grum, USA; Dr. Robert W. Whalin was Technical Director.

CONTENTS

	<u>Page</u>
PREFACE	1
GLOSSARY	3
INTRODUCTION	4
EQUIPMENT USED	5
Computer and Peripheral Equipment	5
Film Reader/Writer	5
DATA PROCESSING PROCEDURES	11
Preprocessing	11
Output Processing	13
ARRANGEMENT OF SUBSET PIXELS	20
SUMMARY	22
TABLES 1-2	
APPENDIX A: PORTRAYAL OF MOBILITY-TERRAIN INFORMATION	A1

GLOSSARY

1. Peel coat - a material, consisting of an amber-colored coating on clear acetate, used by cartographers to manually produce a color separation negative. The amber layer is cut along the boundary of an area and the portion of the coating within the boundary peeled away from the acetate leaving a clear acetate area. The resulting "peel coat" (or window map as they are sometimes called) is required for each color to be printed.
2. Photolithographic printing - a planographic printing process wherein the image to be printed is first formed as a positive on a photosensitized plate.
3. Photopolymer toning - a process for applying color to paper using a laminate of ultraviolet-sensitive photopolymer material. The photopolymer material is sticky until exposed to ultraviolet light. Paper on which the photopolymer has been laminated can be toned (or colored) by dusting it with an inert pigmented powder. The powder will adhere only to the unexposed portions of photopolymer. An image is formed on the paper if exposure to ultraviolet light is made through a transparent positive.
4. Pixel (or picture element) - defines the smallest area over which radiant power is integrated for a measurement.
5. Raster - a predetermined pattern of scanning lines which provide substantially uniform coverage of an area.
6. Real-time data compression - a technique for very rapidly compressing the volume of data to be stored. In the case of the Pagitron system, analog data for line art material are compressed as analog-to-digital conversion takes place for each scan line.
7. Window maps - term used to denote a photographic film on which areas to be printed a given color appear on the film as "windows" or clear areas against a black or opaque background. A window map is required for each color to be printed.



INS. GRA 2	<input checked="" type="checkbox"/>
INS. TAB	<input type="checkbox"/>
Unreproced	<input type="checkbox"/>
Distribution	
By _____	
Unit/Dept _____	
Availability Codes _____	
Dist	Alt. d/or Special
Alt	

COMPUTER TECHNIQUES FOR PRODUCING COLOR MAPS

Introduction

1. One of the primary responsibilities of the Computations and Analysis Group is to develop rapid methods for processing qualitative terrain information from various sources and by the use of established correlative techniques, converting the information to estimated quantitative terrain values in a form suitable for input to a variety of analytical models, such as the Army Mobility Model. Sources of information range from very sophisticated satellite- and aircraft-borne remote sensor data to hand-drawn attribute maps that define the boundaries of terrain areas of interest.

2. To effectively utilize the methodology for correlating and converting the various sources of information to a useful form, a number of computer programs and data processing techniques have evolved that have been successfully demonstrated on a variety of Corps of Engineers problems. One of these is the capability to produce color maps through use of computer techniques. Development of this capability was motivated by the fact that needs exist for techniques for preprocessing and checking digital terrain information that is to be used as input to the Army Mobility Model and to produce displays or maps depicting the output of the model. As a result, the direction taken in developing this capability was dictated by the fact that:

- a. The input would define a terrain area by an orthogonal array of measurements recorded digitally in a format that would permit the measurements to be easily converted to an image on photographic film (image format).
- b. The output had to be compatible with photopolymer toning and photolithographic printing techniques.

3. Demonstration projects in cooperation with the U. S. Geological Survey (USGS), Reston, Va., have indicated that, although the procedures were originally developed with a somewhat different purpose in mind, they may also serve to effectively circumvent some of the laborious, time-consuming tasks normally associated with map production. This paper will discuss these procedures as they were implemented in connection with the demonstration projects for USGS. In addition, an example of the techniques used for verifying quantitative terrain information for input to an analytical model will be presented.

Equipment Used

4. The two primary items of equipment used at the WES to produce color maps are a Digital Equipment Corporation PDP-15 computer and an Optronics International Photomation Mark II system.

5. Limited use has been made of a Pagitron Model P1722 system to gain insight into the potential use of high-speed map digitization and printing, and real-time data compression techniques in color map production.

Computer and peripheral equipment

6. The PDP-15 computer (Figure 1) has 24,000 words of magnetic core storage and two disk storage units. Input and output of the digitized image data are accomplished by means of magnetic tapes. A Tektronix Model 4014-1 cathode ray tube terminal is used for operator control of computer operation and observation of the digitized imagery.

Film reader/writer

7. The Photomation Mark II system (Figure 2a) is an electromechanical drum-type film-scanning and film-writing system designed to accept film sizes up to and including 22.8 by 22.8 cm (9 by 9 in.). In the film reading or input mode, a film transparency is clamped to a drum (shown schematically in Figure 2b) so that the film adheres exactly to the machined cylindrical surface of the drum. A light source and a photodetector are mounted on opposite arms of a carriage within which the drum rotates. An opening in the drum allows light from the source to be transmitted through the transparency to the detector. As the drum rotates, the optical density of successive square spots (pixels) on the film along the circumference of the drum (Y direction) is measured at a selected raster interval. The pixels can be 0.0125, 0.025, or 0.050 mm in size. The raster interval is normally selected to be equal to the pixel size. After each drum revolution, the carriage is stepped in the axial (X) direction a distance equal to the raster interval and the process is repeated until the desired area of the film has been scanned.

8. The output of the photodetector is amplified and converted to digital form; the results are recorded on computer-compatible tape (CCT) as values (gray levels or gray values) between 0 and 255. At the discretion of the operator, 0 may be white and 255 black, or vice versa, depending upon project requirements. Line art or continuous-tone photographs recorded on



Figure 1. Computer and peripheral equipment



Figure 2a. Film reader/writer

film can be scanned without filters or using a blue, green, or red filter to extract information from specific bands on such items as color and color-infrared photos.

9. In the film-writing or output mode, the film reader/writer (shown schematically in Figure 2c) is equipped with a rotating drum and an optical system consisting of a light-emitting diode (LED), a selectable aperture, and a lens system that focuses a spot of light from the LED onto the periphery of the drum. The drum is housed in a light-tight enclosure, which is demountable and is removed to a photographic darkroom to load and unload the film. A piece of film is clamped to the outside of the drum. As the drum rotates, the light intensity of the LED is modulated incrementally over a range of CCT values from 0 to 225 to expose the film. Kodak Linagraph Sheelburst film, Type 2474, is used for this application.

10. The film is normally exposed at the same pixel size and raster interval as used in the reading mode. As the drum rotates, the carriage supporting the optical system is stepped incrementally in the axial (X) direction at the selected raster interval until the total area of the film or the area of interest has been exposed.

11. The instrument is controlled by a minicomputer which permits real-time manipulation of the digitized density data to produce a number of photographic effects.

12. The Pagitron Large Format Image Data system (Figure 3) is similar in concept of operation to the Photomation, but incorporates several features that make this system especially attractive for map digitization and color map production. Like the Photomation, the Pagitron is an electromechanical drum-type system. However, where the Photomation is designed to scan and digitize film transparencies up to 22.8 by 22.8 cm in size, the Pagitron is designed to rapidly scan and digitize line art and continuous-tone images on opaque material up to 43.2 by 53.3 cm (17 by 21 in.). The system incorporates run-length encoding to achieve real-time data compression and stand-alone interactive graphic capabilities that permit real-time additions, deletions, or corrections to the digitized data. The output of the system can be recorded on a plate-ready photographic film, CCT, or computer disk pack for subsequent storage and retrieval.

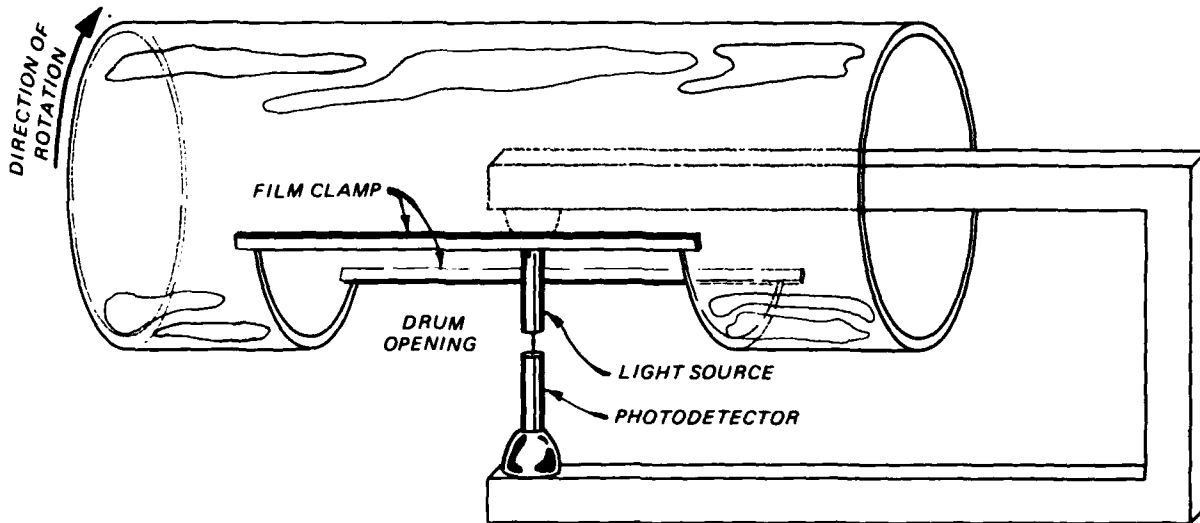

b. Schematic representation of film reading assembly.

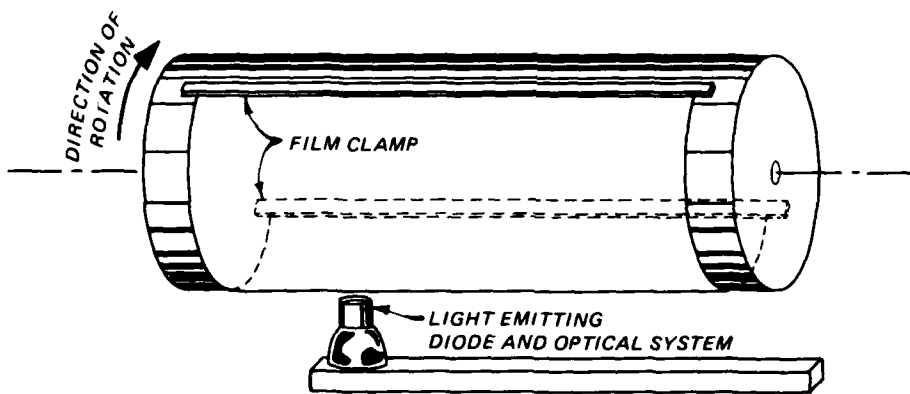

c. Schematic representation of film writing assembly.

Figure 2. Film reading/writing assembly

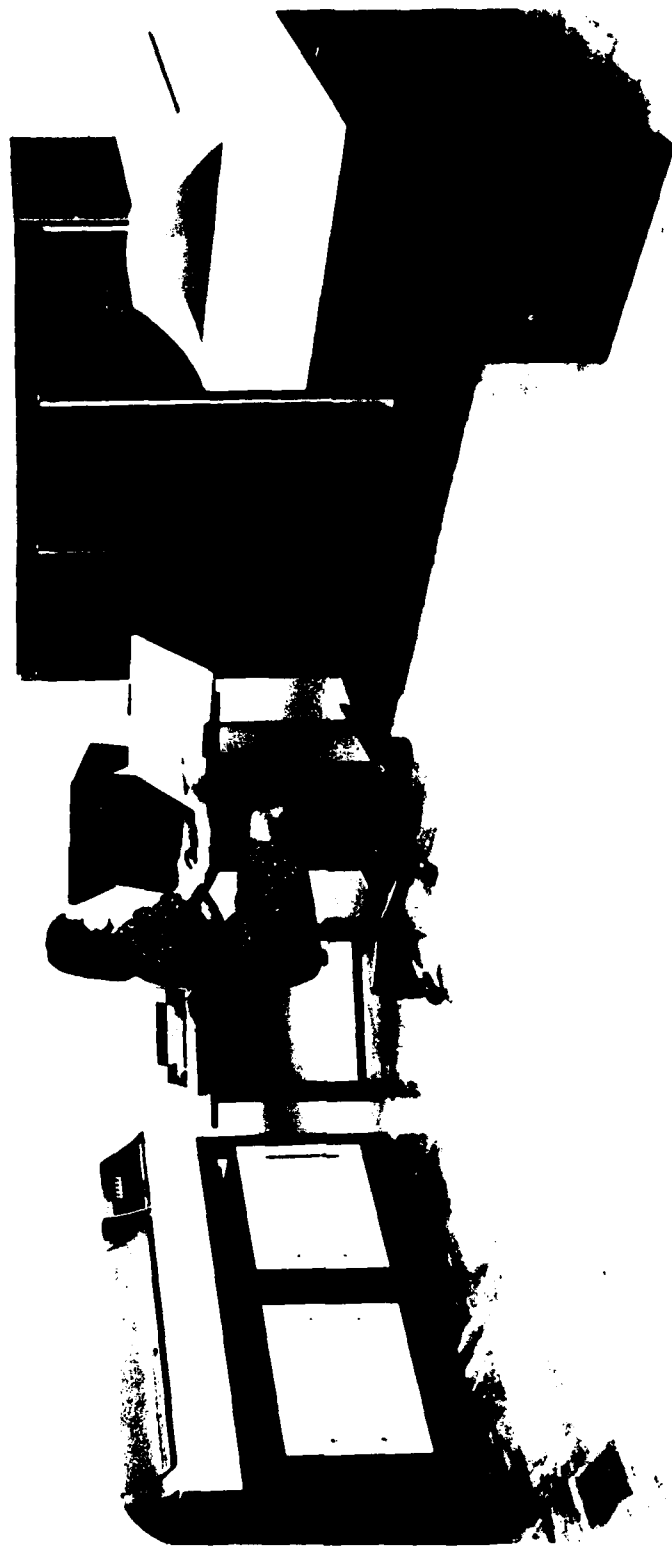

Figure 3. Large format image data system

Data Processing Procedures

13. A typical map to be colored is portrayed as a set of boundary lines that separate homogenous areas (polygons) according to some identifiable terrain attribute, such as soil type or land use. The data processing required for color map production falls into two general categories: preprocessing and output processing. The preprocessing steps are required inalterably, whether the intended output is to be an input to an analytical model, or a product compatible with the photolithographic printing or photopolymer toning process. On the other hand, output processing steps may vary somewhat depending upon the desired output product.

Preprocessing

14. The purpose of preprocessing is to convert a map in graphic form to a digital form suitable for subsequent data processing. Preprocessing is accomplished in five steps: data encoding, editing, factoring, attribute coding, and output recording.

15. Data encoding. Input data to be encoded are in the form of line art drawn on a stable-base drafting material with lines drawn in black against a white background. Encoding is done with either of the Optronics International digitizing systems.

16. Maps to be encoded on the Photomation system are normally photographically reduced in size so that the entire area of the map will appear within the 22.8- by 22.8-cm (9- by 9-in.) opening in the scanner drum.

17. Materials to be encoded on the Pagitron system can normally be used without photo-reduction since the large format of this system is designed to accommodate most standard map products.

18. Any map that has been encoded is described by a set of measurements that define the map as an orthogonal array of pixels. A measurement is taken and recorded on a CCT for each pixel in the array. Measurements for pixels pertaining to lines are characteristically recorded as low values (< 100) while all other areas of the encoded material result in high recorded values. At the end of each row of pixels in the array, an interrecord gap (IRG) code is automatically recorded to signify that recordings for the next row of pixels are about to begin. The measurement for the last pixel on the last row of pixels is followed by an end-of-file code that is automatically recorded on the CCT.

19. By this process, the measurement for each pixel in the grid is recorded. At the same time, the location of each pixel with respect to all other pixels in the grid is implied by the location of the recorded value on the CCT. The value for any pixel can be located on the CCT in terms of its x-y position simply by counting IRG's to find the desired row (y-value) and counting the pixel values to the desired position (x-values).

20. Data recorded in this manner are commonly referred to as being in image format and can be easily converted to an image on photographic film or a CRT monitor.

21. Editing. The edit step is accomplished by operator interaction with the encoded data via the Tektronix Model 4014-1 CRT terminal. The entire data base or selected portions of the data base are displayed at any desired magnification. The value of individual pixels or selected horizontal, vertical, or diagonal lines of pixels are then changed as requirements dictate to, in effect, make real-time additions, deletions, or modifications to the encoded data. For example, a break in a line can be corrected by converting the pixels forming the break to a specified number less than 100, thus redesignating the pixels as "line" pixels.

22. When consideration is given to the fact that a one-pixel-wide break in an encoded line can result in misidentification of an entire map area in a subsequent step, the importance of the edit step cannot be overstated. Therefore, very careful consideration must be given to the manner in which this step is accomplished. Ideally, maps and charts to be encoded should have lines of uniform weight and density that are clearly separated from any other lines nearby. Then the edit process becomes primarily a rapid review of the encoded data as the data are displayed on the CRT. However, as the quality of the images to be processed decreases, the time required to complete the edit process increases rapidly to the point where costs become a major consideration.

23. Factoring. Up to this point we have been concerned with converting a map to be colored to a digital form and accurately differentiating lines and spaces in the digital data base. Factoring is the process of differentiating polygons defined by the boundary lines. This is altogether a computer process that sorts the group of pixels defining each polygon (i.e., all contiguous pixels having a value greater than 100 bounded by contiguous pixels having a value less than 100) into a separate, but yet unidentified,

computer file. Factoring results in a computer file being established for each polygon of the map.

24. Attribute coding. Attribute coding is required to establish the identity of each file resulting from factoring, and, thus, each polygon. Attribute coding again invokes the interactive graphic capabilities provided by the Tektronix Model 4014-1 CRT terminal.

25. To facilitate coding, displays of the factored map are "written" on the CRT in sequence. Each display shows the boundary lines of the map with the pixels from one unidentified file pertaining to one of the polygons highlighted. A computer operator then enters an identification number for the file pertaining to the highlighted polygon. The display is then erased and a display of the same map with another polygon highlighted is "written." Again the operator enters an appropriate identification number. This process is repeated until all files have been given an identification number.

26. Attribute coding is completed by converting the pixel values in each file (which to this point have been a variety of numbers greater than 100) to the identification number assigned to that file. The results are recorded on a CCT for subsequent use.

27. Upon completion of this step, all lines forming boundaries for polygons are "distributed." The pixels defining the width of each line are distributed equally to the adjacent polygons by converting line pixels to the attribute codes of the adjacent polygons separated by the lines.

28. Output recording. The results of this final step are recorded on a CCT which contains the digitized map defined by an appropriate attribute code for all of the pixels defining each polygon. The data are retained in image format for subsequent output processing.

Output processing

29. A number of output processes have been developed at the WES to utilize data that have been preprocessed as described in the preceding paragraphs. However, the scope of this paper limits us to output processing to produce "window maps" as prescribed by the USGS and color separations suitable for producing color maps by photopolymer toning procedures.

30. Window maps. From a cartographic standpoint, window maps serve much the same purpose as "peel-coats." However, window maps are produced by exposing photographic film. Consider as an example the map (Figure 4) recently completed for the USGS.



Figure 4. Aeromagnetic map produced by USGS and used to produce window maps

31. This map was encoded and preprocessed using the procedure described previously. The polygons were each assigned an attribute code between 1 and 12 to correspond to one of the 12 different colors to be used in the final map. A hand-colored index map furnished by the USGS was used in making assignments.

32. Prior to encoding, the map had been photographically reduced in size 5.0 percent. In anticipation of photographically enlarging the window maps back to the original map size, the film transparencies resulting from output processing were to show areas of interest as black against a clear film acetate background. Then, the results of the enlarging process would be a window map on which the area of interest would appear clear against an opaque background.

33. One of the features of the film writing equipment is the capability to transform any gray value or range of gray values recorded on a CCT to some other specified gray level on photographic film. This capability is often exploited to increase the contrast of a photographic image, increase or decrease density to compensate for exposure errors, or to emphasize features described by specific gray values. Use of this capability permitted window maps to be produced directly from the CCT's recorded during preprocessing.

34. A window map was produced for each of the 12 colors in the following manner. For the first map, i.e., the window map for the color coded No. 1, the film writer was programmed to expose the film only on those occasions when a pixel value of "1" appeared on the CCT. For the second map, the film writer was programmed to expose the film only on those occasions when a pixel value of "2" appeared on the CCT. This process was repeated until all 12 window maps were completed. In a similar manner, an overlay containing only the boundary lines was produced by programming the film writer to expose the film only when a pixel value of "0" corresponding to a line occurred on the CCT used for line distribution. The result was the set of window maps, examples of which are shown in Figure 5.

35. Color separations. Computer techniques to convert image data to conventional half-tones have been available for a number of years. However, these techniques are very difficult to implement with film writers such as the Optronics systems that have a fixed or operator preset aperture and pixel size. To circumvent this problem an alternate procedure to convert image data to a form that can be used to produce a half-tone film transparency on



a. Relative gamma = 10,800 to 11,000



b. Relative gamma = 10,200 to 10,400

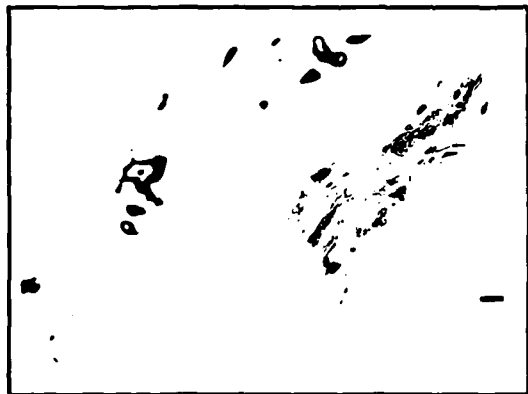

c. Relative gamma = 10,600 to 10,800



d. Relative gamma = 10,000 to 10,200

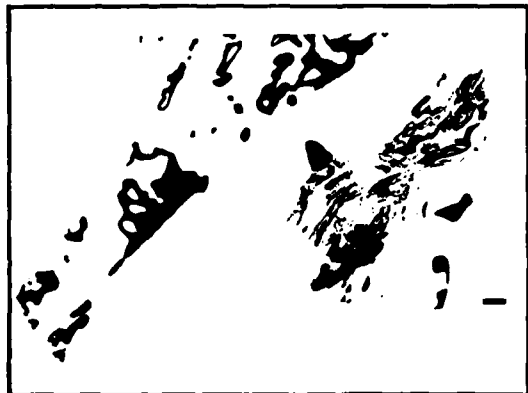

e. Relative gamma = 10,400 to 10,600

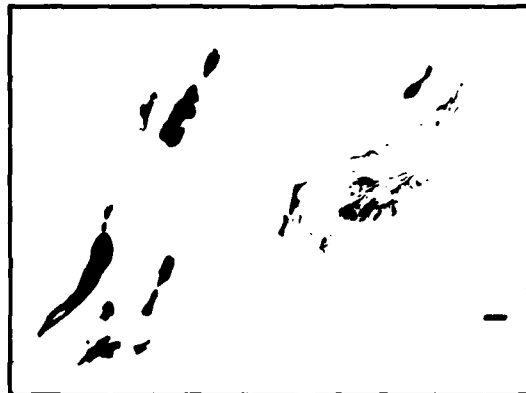

f. Relative gamma = < 10,000

Figure 5. Examples of window maps produced from the USGS map (Aeromagnetic map showing magnetic field intensities in relative gammas)

the Optronics film reader/writer was developed at the WES. In this procedure each pixel in the image data is considered as a 16-pixel subset of pixels in a 4- by 4-pixel array. The relationship of the pixel value(s) on the CCT and the subset pixel or combination of pixels that will ultimately be exposed on film is established by a set of conversion codes that are derived as shown in Figure 6. The location of each subset pixel in the 4- by 4-pixel array is identified in Figure 6a. In Figure 6b, the 16 subset pixels have been arranged in a table in six groups. Each group is considered as being equivalent to a 3-bit binary number. The number is found by selection of the subset pixels to be exposed. If a subset pixel is to be exposed, a "1" is entered in the corresponding block in the row set aside for pixel condition codes. If a subset pixel is not to be exposed a "0" is placed in the appropriate pixel condition code block. In the example shown, subset pixels 1, 3, 4, 8, 10, 12, and 14 are to be exposed. By combining condition codes for each of the six groups, the following binary numbers result: 001, 011, 000, 101, 010, and 100. Converting these to octal numbers results in a conversion code of 130524.

36. After the conversion code has been determined, the pixel value or range of values on the CCT that will result in each subset pixel or pixel combination being exposed is specified. In the example shown in Figure 6, any pixel value between 0 and 44 will be converted to the pixel combination specified by the conversion code 130524. Conversion codes must be established in this manner for all CCT values between 0 and 255. The table of pixel values and corresponding conversion codes can then be used to convert the preprocessed data recorded on CCT to another CCT that contains the data in a form that will result in a half-tone film transparency when the CCT is used as input to the Optronics film writer.

37. An extension of this technique for producing half-tone color separations provides a very useful way to verify the accuracy of a complex digitized map. Consider as an example, the map shown in Figure 7. This map, a water resources map of an area in western Tennessee, defines 65 homogeneous areas and identifies each area by a water resources unit number. When encoded on the film reader/writer, the map was described digitally by an orthogonal array of 0.05- by 0.05-mm pixels. Pixels defining the boundary lines were identified in the recorded output by values greater than 100, while the remaining pixels had values less than 100. After factoring had

1	2	3	4
5	6	7	8
9	10	11	12
13	14	15	16

a. LOCATION OF SUBSET PIXELS IN ARRAY

GROUP NO.	1		2		3		4		5		6					
SUBSET PIXEL NO.	1	2	3	4	5	6	7	8	9	10	11	12	13	14	15	16
CONDITION CODE	0	0	1	0	1	1	0	0	0	1	0	1	0	1	0	0

GREY LEVEL
RANGE 0-44

CONDITION CODE KEY
 1 = PIXEL TO BE EXPOSED
 0 = PIXEL NOT TO BE EXPOSED

NOTE: CONDITION CODE 001, 011, 000,
 101, 010, AND 100 CONVERTS TO
 THE OCTAL NUMBER 130524.

b. CONVERSION CODE DETERMINATION

1	2	3	4
5	6	7	8
9	10	11	12
13	14	15	16

c. RESULTS OF CONVERSION FOR GRAY LEVEL RANGE OF 0 TO 44

Figure 6. Method for determining conversion codes

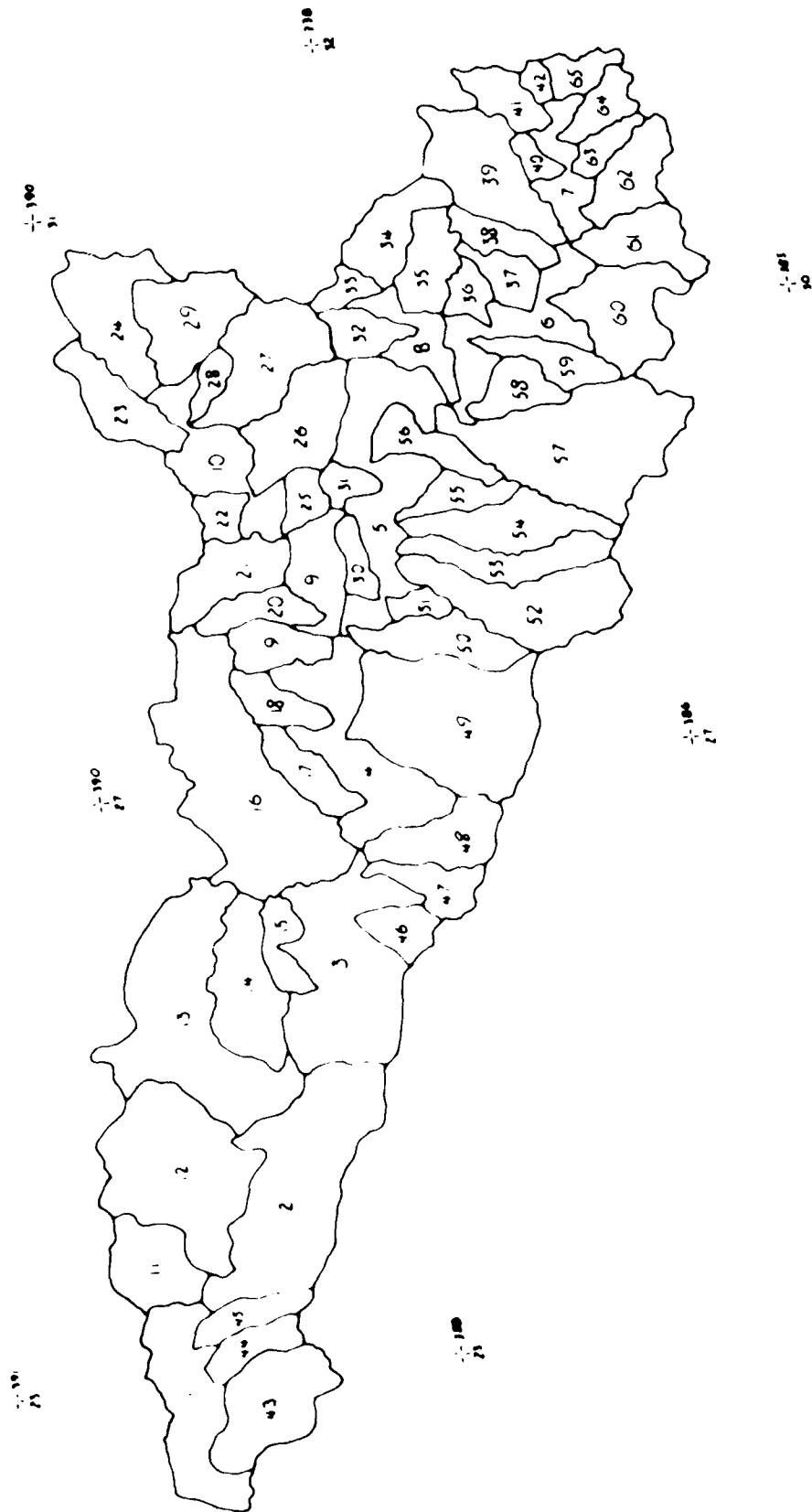

Figure 7. Water resources map of an area in western Tennessee

been accomplished, each pixel that had a value less than 100 was renumbered according to the water resources unit number of the polygon of which it was a part.

38. To verify the map, a photopolymer toning process was used to portray each water resources unit as a different color. Colors were printed as combinations of magenta, yellow, cyan, and/or black. The color separations used in toning were in the form of a positive half-tone transparency for each of the colors used.

39. In preparing the color separations, each pixel was considered as a 16-pixel subset of pixels in a 4-by-4 array. A somewhat different arrangement of the pixels was used for each color as shown in the blocks below.

12	2	10	4
5	13	7	15
9	3	11	1
8	16	6	14

Magenta

13	7	15	5
3	11	1	9
16	6	14	8
2	10	4	12

Yellow

14	8	16	6
4	12	2	10
15	5	13	7
1	9	3	11

Cyan

11	1	9	3
6	14	8	16
10	4	12	2
7	15	5	13

Black

Arrangement of Subset Pixels

40. Table 1 gives the colors used for each polygon, stated in terms of percent magenta, yellow, cyan, and/or black. The percentages refer to the portion of the 4-by-4 array that was exposed on the film by the film reader/writer. Thus, 75 percent means that 12 of the 16 subset pixels in the array were exposed.

41. Once the desired colors were selected, conversion codes to produce each color separation were derived using the procedure described in paragraph 35. As a result of the arrangement of subset pixels being different for each color, unique conversion codes emerged for each color as can be seen in Table 2.

42. The color map that resulted from application of this procedure is shown in Figure 8. It can be seen that each of the 65 polygons is portrayed with a different color, a condition that facilitates each visual check of map accuracy.



Figure 8. Color rendition of water resources map

Summary

43. The results of this work indicate that by a transfer of technology normally used in the field of analytical modeling to the field of automated cartography, a computer-oriented procedure has evolved for encoding maps in a manner that can permit rapid production of window maps and color separations. Experience has shown, however, that the cost-effectiveness of this procedure is dependent to a large extent on the quality of the map product to be used as input. Perhaps some standardization of procedures for preparing maps prior to encoding is in order. In addition, further research and experience may reveal long-term mass data storage techniques that are compatible with maps encoded in the manner described, thus resulting in a procedure for rapidly archiving, retrieving, and updating map sheets and data used to produce maps.

Table 1
Color Combinations for Producing Color Separations

Polygon No.	Percentage			
	Magenta	Yellow	Cyan	Black
1	0	0	75	0
2	20	0	75	0
3	40	0	75	0
4	55	0	75	0
5	75	0	75	0
6	0	0	55	0
7	0	0	55	20
8	0	0	40	20
9	0	0	20	20
10	0	0	75	20
11	0	55	75	0
12	55	55	75	0
13	40	55	75	0
14	20	55	75	0
15	75	55	75	0
16	0	75	0	0
17	0	75	0	20
18	0	75	0	40
19	0	75	0	55
20	20	75	0	0
21	40	75	0	0
22	75	75	0	0
23	20	75	55	0
24	40	75	55	0
25	55	75	55	0
26	75	75	55	0
27	0	75	20	0
28	20	75	20	0
29	40	75	20	0
30	55	75	20	0
31	75	75	20	0
32	20	75	0	20
33	20	75	0	40
34	20	75	0	55
35	0	75	75	0
36	0	75	55	0
37	0	75	40	0
38	55	75	0	0
39	40	40	0	0
40	40	40	0	20
41	40	40	0	40
42	55	40	0	0
43	75	40	0	0

(Continued)

Table 1 (Concluded)

Polygon No.	Percentage			
	Magenta	Yellow	Cyan	Black
44	0	40	20	0
45	20	40	20	0
46	40	40	20	0
47	55	40	20	0
48	75	40	20	0
49	0	40	40	0
50	20	40	40	0
51	40	40	40	0
52	55	40	40	0
53	75	40	40	0
54	0	40	55	0
55	20	40	55	0
56	40	40	55	0
57	55	40	55	0
58	75	40	55	0
59	0	40	75	0
60	20	40	75	0
61	40	40	75	0
62	55	40	75	0
63	75	40	75	0
64	55	20	75	0
65	75	20	75	0

Table 2
Conversion Codes

<u>Percentage</u>	<u>Magenta</u>	<u>Yellow</u>	<u>Cyan</u>	<u>Black</u>
75	177714	174637	03177	067766
55	137610	170427	021357	046764
40	007610	170420	021017	040364
20	003400	160000	000015	000260

APPENDIX A: PORTRAYAL OF MOBILITY TERRAIN INFORMATION

Background

1. In late 1969, the US Army Engineer Waterways Experiment Station and the US Army Tank-Automotive Command undertook a joint program to incorporate research and engineering technology of terrain-vehicle-man interactions available at that time into a comprehensive computerized simulation of a vehicle moving across an area of terrain. The result of this work was the Army Mobility Model (AMM).

2. The AMM predicts vehicle speed and other performance measures within, across, or on a single terrain unit (areal patch, linear feature, or road segment). By making predictions for all terrain units within a geographical area, the AMM, in effect, checks vehicle performance throughout an entire area.

3. Principal elements of the AMM are three independent computational modules--the areal patch module, the linear feature module, and the on-road feature module. The areal patch module computes the maximum first-pass speed for a single vehicle in a single areal terrain patch or terrain unit. The linear feature segment module computes the minimum feasible time for a single vehicle, aided or unaided, to cross one time a uniform segment of a significant linear terrain feature, such as a stream, ditch, or embankment. The on-road segment module computes the maximum feasible first-pass speed of a single vehicle traveling along a uniform segment of a road or trail.

4. All three modules of the model draw from a data base that contains quantitative descriptions of the vehicle, the driver, and the attributes of the terrain to be examined in the simulation. Each vehicle is described in the data base in terms of the geometric, inertial, and mechanical characteristics that influence the manner in which the vehicle interacts with the terrain. Driver attributes used in the data base describe the driver with respect to his limiting tolerance to shock and vibration, his ability to perceive and react to visual stimuli that affect his performance as a vehicle operator, and a minimum acceptable speed for which he will strive regardless of constraints imposed by comfort and visibility considerations. The terrain may be described for any given time by as many as 22 mathematically independent terrain factors for each areal unit, 10 factors for the cross-section and

hydrologic characteristics of a linear feature to be negotiated by the vehicle, and 8 factors to describe a road segment.

5. Terrain information used in the AMM may originate from a variety of sources. Information on soil type, vegetation characteristics, elevation, location of obstacles, etc., may originate from available maps or charts. On the other hand, all or some portion of the required information may be available only via a remote sensor, such as the Landsat multispectral scanner, aerial photography, synthetic aperture radar, or laser profilometer. Some special types of information may be derived only from statistical tabulations or field notes.

6. Regardless of the source, terrain information required as input to the AMM is normally reduced to a set of maps or map overlays. Features, such as land use, vegetation characteristics, geological features, and soil type, are defined as homogenous areas (polygons) separated by boundary lines. Each area is identified as shown in Figure A1 by a code that identifies the characteristic(s) that make the area unique. Terrain features, such as escarpments, embankments, elevations, roadways, rivers, or streams are defined as linear features. As shown in Figure A2, each line, line segment, or point is identified by a code that pertains to the qualities that make the feature unique.

7. Reliable modeling of terrain-vehicle-driver interactions and responses required to predict vehicle performance requires extensive quantitative information on cross-country terrain, streams and gaps, and road networks over large geographic areas. To meet this need, research was initiated by the Computations and Analysis Group¹ in late 1976 to improve techniques and procedures for acquiring the needed information, manipulating and storing the data, retrieving the stored data, and portraying the results of data processing in familiar, easy-to-use forms. This research showed that the field of image data processing, a field made prominent by the launch of the first Landsat satellite in 1972, was characterized by techniques and procedures useful not only for satellite remote sensing but also for rapidly encoding maps to be used with analytical models. Armed with these findings, instruments and data processing techniques normally associated with image

¹ Computations and Analysis Group, Mobility Systems Division, Geotechnical Laboratory.



Figure A1. Example of areal map

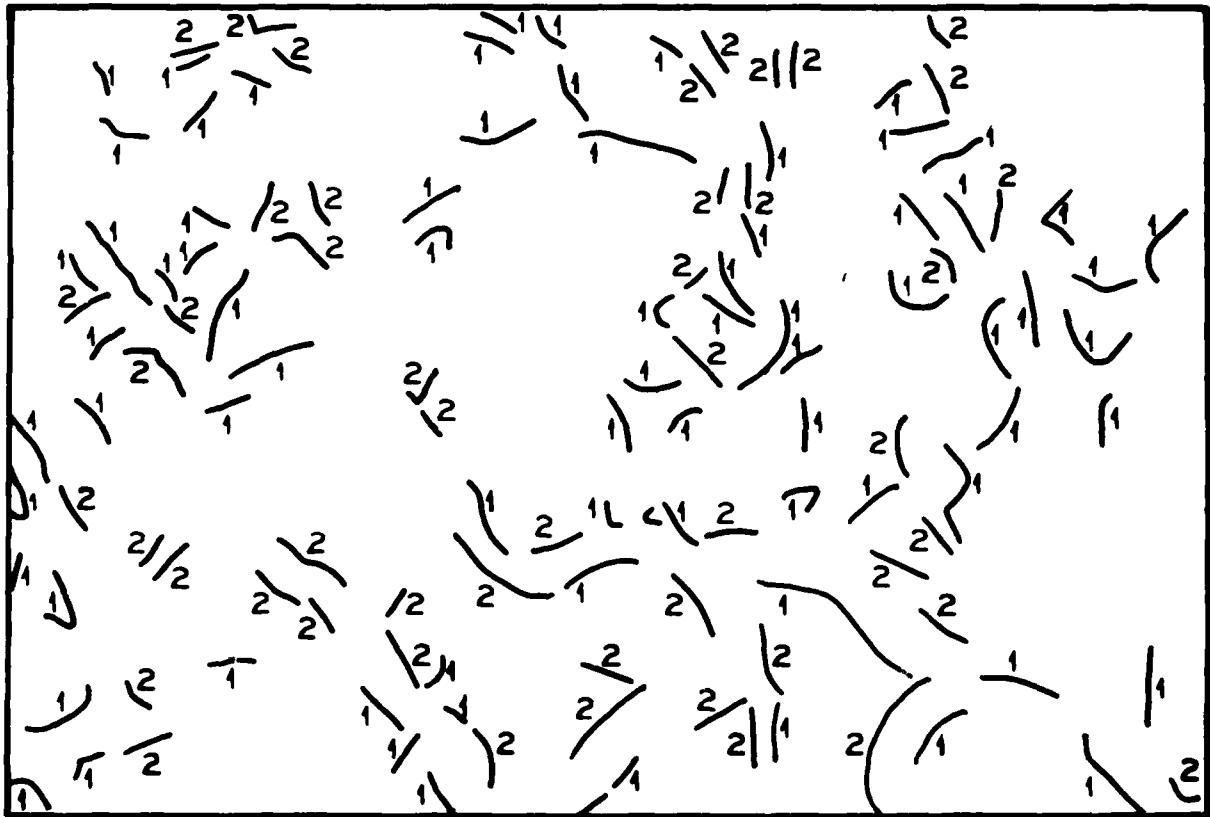

Figure A2. Example of linear map

data processing were adapted so that terrain information can now be digitized routinely, interactively checked for accuracy and edited, adjusted to the scale and resolution dictated by project requirements, and stored for future use. As project requirements dictate, the resulting mobility-terrain data base can be used, in toto, or in part, to solve a variety of problems. The results can then be displayed as a CRT display, or portrayed as a black-and-white or color image.

8. The paragraphs that follow discuss the equipment and the procedures developed to produce color-coded portrayals of vehicle performance.

Data Processing

9. Investigations of available hardware showed that vehicle performance information generated by the AMM could be rapidly portrayed as a color-coded map or map overlay through use of a tri-color image data converter.

Output of the Army Mobility Model (AMM)

10. One of the outputs of the AMM is a computer-compatible magnetic tape formatted much like the output tape from the film reader/writer. A geographic area is described on the tape as a set of values that define the area as an orthogonal array of pixels. However, where the output of the film reader is a record of gray levels or gray values ranging between 0 and 255 for each pixel, the output of the AMM is a record of vehicle speed in miles/hour for each pixel.

11. A value is recorded for each pixel in the array. At the end of each row of pixels in the array, an interrecord gap (IRG) code is recorded to signify that recordings for the next row of pixels are about to begin. The value for the last pixel on the last row of pixels is followed by an end-of-file code that is automatically recorded on the tape. This format preserves the spatial integrity of the data, thereby permitting the data to be used to portray the results as an image or map.

Tri-color image data converter

12. The tri-color image data converter (Figure A3) is designed to rapidly produce graphic displays in full color on paper, clear acetate or other absorbent material. With this system, color-coded displays up to 55.9- by 86.4-cm (22- by 34-in.) in size can be produced in as little as



Figure A3. Tri-color image data converter

8.5 min. The input to the image data converter is a computer-compatible magnetic tape that has been formatted on a host computer to meet the input requirements of the image data converter. The image data converter is comprised of two major subsystems--the color plotter and a magnetic tape reader.

13. Color plotter. The color plotter is the heart of the system. As shown in Figure A4, the plotter has a scanning drum, lead screw, ink-jet nozzles, a mounting block for the nozzles, a stepping motor, and ink pumps, as well as associated electronic circuits for controlling and synchronizing the entire operation of the plotter and tape reader.

14. To print information, an absorbent material is mounted on the drum. As the drum rotates, constant size droplets of magenta, yellow, and cyan ink are emitted from the nozzles at a rate of 125 droplets (points)/in. along the circumference of the rotating drum. Each time the drum completes one revolution, the lead screw driven by the stepping motor causes the block upon which the nozzles are mounted to be advanced approximately 0.008 in. axially.

15. A completed 22- by 34-in. graphic produced on the image data converter is comprised of an orthogonal array of pixels arranged with 4250 (125 points/in. \times 34 in.) pixels along the length and 2750 (125 points/in. \times 22 in.) across the width. A single graphic product can be plotted with magenta, yellow, and/or cyan ink over the entire area or any part thereof. Since a matrix is required for each of the three colors, a total of over 35 million bits ($4250 \times 2750 \times 3$) of information are required to describe a full-sized portrayal.

16. Tape reader. The tape reader reads a standard 0.5-in. computer tape that has been recorded at a density of 800 bpi on 9 tracks. Acting entirely under control of a microprocessor unit (MPU) in the color plotter, the tape reader first reads the data required for printing magenta, yellow, and cyan along the first line in the direction of drum rotation. Once all the data for the first line have been read and stored in a memory buffer, the MPU then requests the second line of data to be read from the tape and stored in a second memory buffer while the output of the first memory buffer is concurrently being used by the image data converter to plot the first line. Once all of the data from the first memory buffer have been plotted, the MPU requests the third line of data to be read from the tape and stored in the first memory buffer while data in the second memory buffer are being plotted.

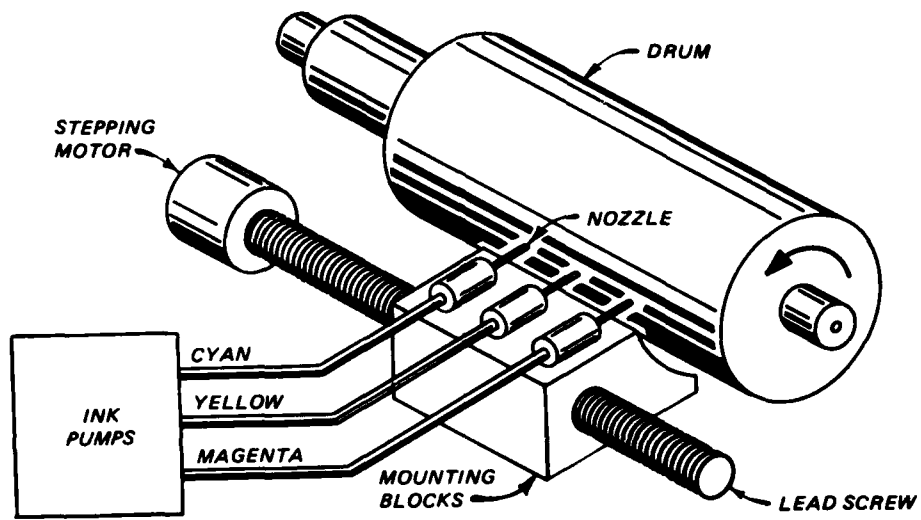

Figure A4. Plotting mechanism of the tri-color image data converter

This process is repeated until all of the data on the tape have been read and plotting has been completed.

Data format

17. Data are recorded on tape as 8-bit bytes, plus an odd parity bit. A complete portrayal is stored as a single file. A file may consist of a maximum of 4250 blocks--one block for each column of points plotted, plus an end-of-file (EOF) block.

18. Figure A5a shows the data format in block N. The first group of 432 bytes corresponds to the magenta line in column N. Since the yellow ink nozzle is physically displaced on the mounting block 10 mm (equivalent to 50 scan lines) away from the magenta nozzle, the second group of 432 bytes corresponds to the yellow line in column N-50. The cyan nozzle is similarly displaced 50 lines away and thus the third group of 432 bytes corresponds to the cyan line in column N-100. The last data byte is followed by an end-of-block (EOB) which incorporates check characters and an interrecord gap (IRG) code.

19. Figure A5b shows the placement of information on a 22- by 34-in. piece of paper mounted on the drum of the image data converter. Note that although 432 bytes (3456 bits) of information are stored on the tape for each color, the last 88 bytes and the last 2 bits of the 344th byte (706 bits in all) fall outside the usable plotting area, leaving only 2750 points that may be plotted.

20. The location of the bytes in block N is shown in the figure. The first byte appears at the bottom of the magenta line number N starting with the most significant bit (MSB) and ending with the least significant bit (LSB). Then, consecutive bytes form the vertical line until the upper limit is reached at byte 344, a part of which is outside the area of the paper. In the same way, bytes 433 to 776 concurrently form the yellow line number N-50 and bytes 865 to 1208 form the cyan line N-100.

21. After the magenta, yellow, and cyan lines have been formed for the bytes recorded in data block N, the block on which the ink nozzles are mounted advances one 0.2-mm increment and plotting of bytes in block N + 1 begins. This process is repeated until the tape reader reads an EOF code, at which time the image data converter turns off.

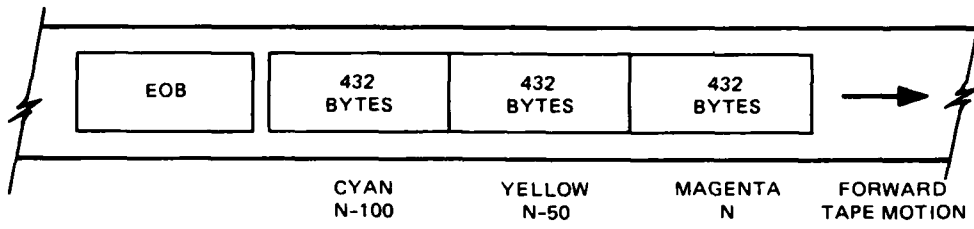

a. DATA FORMAT OF BLOCK NUMBER N ON A COMPUTER COMPATIBLE-MAGNETIC TAPE FOR THE TRI-COLOR IMAGE DATA CONVERTOR

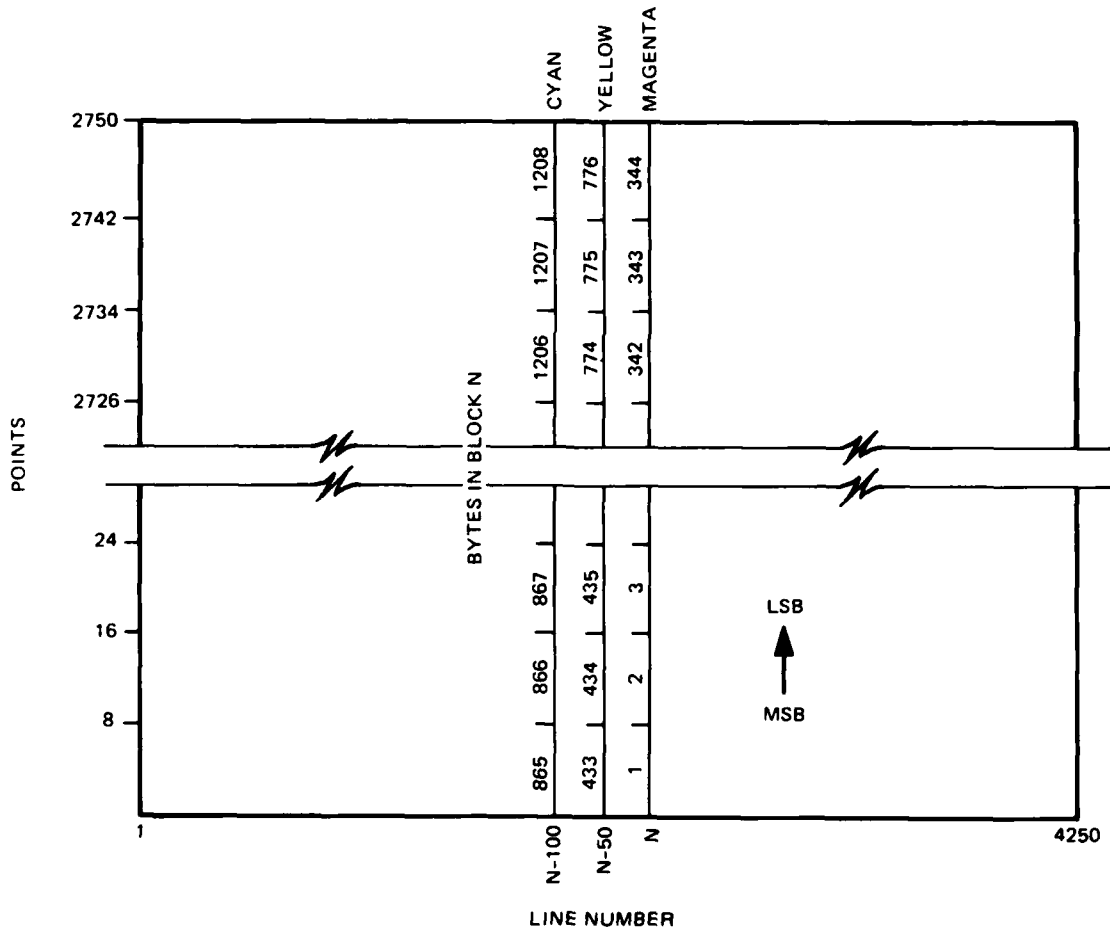

b. LOCATION OF POINTS IN BLOCK N PRINTED ON A 22- BY 34-IN. PIECE OF PAPER

Figure A5. Data format on tape and location on printed paper

Color coding technique

22. A bit recorded on tape may be either a "1" or a "0." A "1" bit results in a spot of ink being deposited on the material mounted on the drum. A "0" bit results in the droplet being deflected away from the drum. Thus, the tape contains information that controls the presence and absence of magenta, yellow, and cyan ink on the material being printed. By judicious use of this feature, shading within an area can be achieved by controlling the percentage of total pixels in an area within which ink is deposited. At the same time coloring can be controlled by applying the magenta, yellow, and cyan ink in various combinations.

23. To capitalize on this capability, a computer program (POSTER) was developed to convert the output data from the AMM to a format acceptable to the image data converter. In the process, shading and coloring are applied to convey information of interest. The computer program considers each grid cell of AMM data as a 16-pixel subset of pixels in a 4- by 4-pixel array for magenta, yellow, and cyan. The location of the subset pixels within the array for each color is shown below.

Magenta				Yellow				Cyan			
12	2	10	4	13	7	15	5	14	8	16	6
5	13	7	15	3	11	1	9	4	12	2	10
4	3	11	1	16	6	14	8	15	5	13	7
8	16	6	14	2	10	4	12	1	9	3	11

It can be seen that the location of subset pixels within the array depends upon the color. For example, subset pixel number 1 is located in row 3 column 4 for magenta, row 2 column 3 for yellow, and row 4 column 1 for cyan. This arrangement is inviolate and is incorporated into the computer program, POSTER.

24. Two tables are required to operate POSTER. One table contains a list of colors defined in terms of the number of magenta, yellow, and cyan pixels within the 16-pixel array that will be plotted. By careful selection of magenta, yellow, and cyan combinations, coloring and shading can be chosen that will most clearly portray the results in the output product. The other table contains a value between 0 and 255 that pertains to each of the magenta, yellow, and/or cyan combinations. This value may be the single value or the lowest value in a range of values that POSTER will convert.

Example of vehicle performance portrayal

25. A typical vehicle performance map produced by the aforementioned procedure is shown in Figure A6. In this example, the performance of a tank is shown for an area in the central highlands of the Federal Republic of Germany (FRG).

26. Critical speeds for purposes of analysis were 0 to <3, 3 to <10, 10-20, and >20 mph. Thus the following table was formulated to portray the output of the AMM for the given tank operating in this study area.

Class	Speed (mph)	Color			Value
		m	y	c	
1	0 - <3	16	00	00	0
2	3 - <10	02	10	00	3
3	10 - 20	00	08	04	10
4	>20	00	08	12	21
5	lettering and boxes	16	16	16	255

In Figure A6, it can be seen that class 1 areas are printed magenta, class 3 areas are printed yellow with magenta dots, class 3 areas are printed light green (achieved by combining yellow and cyan), and class 4 areas are printed dark green (also achieved by combining yellow and cyan, but in higher concentration). Lettering and boxes are black.

Results

27. The result of this work provides a clear, easy-to-use, portrayal of vehicle performance within the study area. The selected colors clearly differentiate among the performance classes and provide the observer with not only a clear assessment of vehicle performance within the area as a whole, but also specific locations within the area.

28. Since the tri-color image data converter can print on most absorbent materials, the portrayals of vehicle performance can be printed on clear acetate suitable for viewgraph projection or for direct overlay on a base map as well as ordinary paper.

VEHICLE: TANK
SEASON: DRY
RESOLUTION: 250m

FEDERAL REPUBLIC
of GERMANY
CENTRAL HIGHLANDS

SCALE: 1:350,000

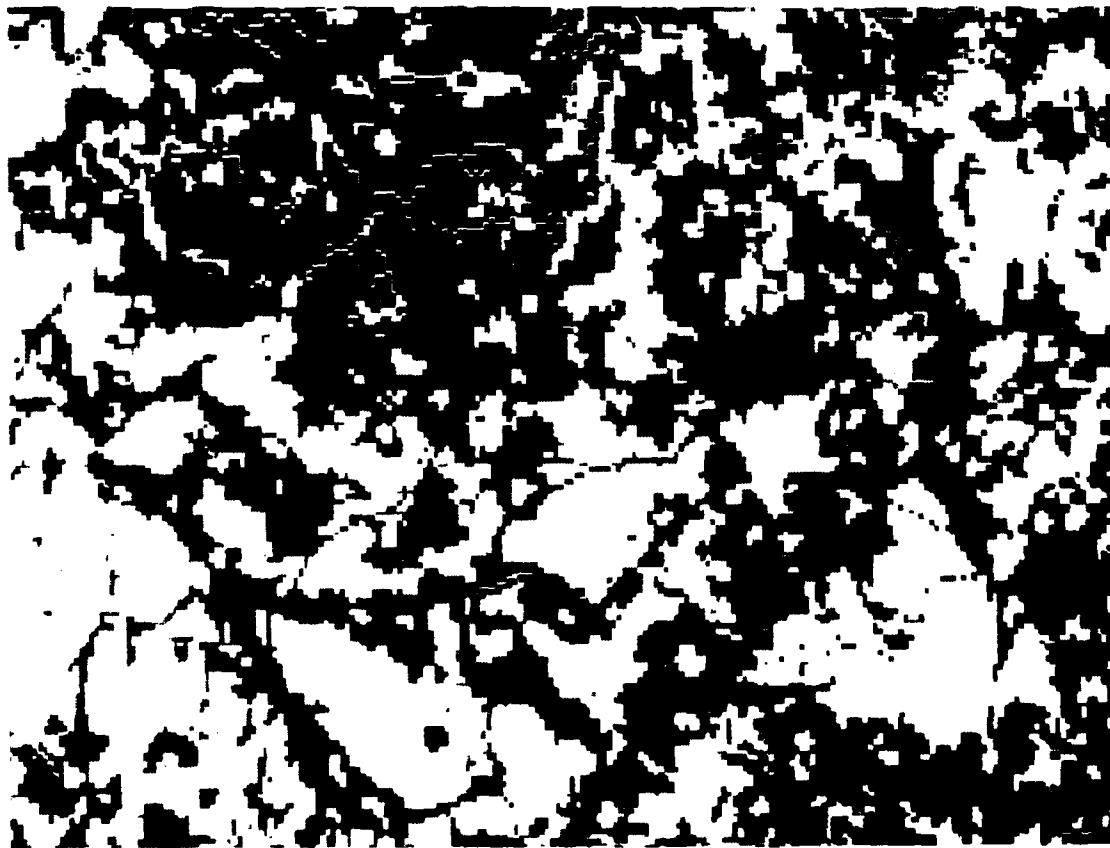

Legend:

0 - < 3 MPH

3 - < 10 MPH

10 - 20 MPH

> 20 MPH

Figure A6. Example of a vehicle performance map

END

FILMED

12-85

DTIC