

AD-A161 199

DEVELOPMENT OF A LOW NOISE 10K REFRIGERATION SYSTEM(U)
MMR TECHNOLOGIES INC MOUNTAIN VIEW CA OCT 85
N00014-85-C-0428

1/1

UNCLASSIFIED

F/G 13/1

NL

								END				
								FUMLD				
								DFIC				

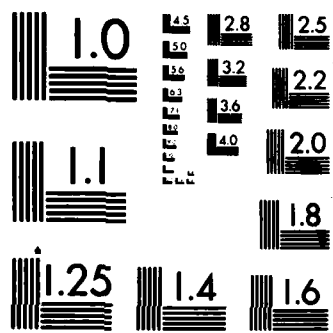

MICROCOPY RESOLUTION TEST CHART
NATIONAL BUREAU OF STANDARDS-1963 A

AD-A161 199

Progress Report #0001AB

Development of a Low Noise 10K Refrigeration System

ONR Contract N00014-85-C-0428

MMR Technologies, Inc.
1400 Stierlin Road, A-5
Mountain View, CA 94043

(415) 962-9620

October 1985

DTIC FILE COPY

DTIC
ELECTE
NOV 18 1985
S D E

This document has been approved for public release and sale; its distribution is unlimited.

85 11 12 019

Abstract

The purpose of this contract is the development of a Low Noise, Closed Cycle, Joule Thomson refrigeration system for 10K operation. This report summarizes work completed to date on the detailed thermodynamic analysis and physical design of the refrigerator. A complete enthalpy balance for the three stage device is presented. Fabrication of the first two refrigeration stages (argon and hydrogen) has begun. A prototype compressor for single gas operation has been designed and tested successfully. ✓

Accession For	
NTIS GRA&I	<input checked="" type="checkbox"/>
DTIC TAB	<input type="checkbox"/>
Unannounced	<input type="checkbox"/>
Justification	<input type="checkbox"/>
<i>form 50 per</i>	
By	
Distribution/	
Availability Codes	
Avail and/or	
Dist	
<i>A-1</i>	



Table of Contents

1.0	Introduction.....	2
2.0	Refrigerator Design.....	2
2.1	Thermodynamical Analysis.....	2
2.1-1	Enthalpy Balance - Helium Stage.....	2
2.1-2	Enthalpy Balance - Hydrogen Stage.....	5
2.1-3	Enthalpy Balance - Argon Stage.....	5
2.2	Heat Exchanger Operation/Estimates of Maximum Allowable Approach Temperatures.....	7
2.3	Physical Design/Function.....	9
3.0	Compressor.....	12
3.1	Component Description.....	13
3.2	Design Philosophy.....	13
3.3	Performance.....	13
3.4	Results and Discussion.....	15
4.0	Objectives of the Next Reporting Period.....	15
5.0	Glossary.....	18

1.0 Introduction

This report summarizes the results of an engineering design program undertaken by MMR Technologies, Inc., for the Office of Naval Research under Contract No. N00014-85-C-0428. The purpose of this program is to develop a low noise, closed cycle, Joule-Thomson, microminiature refrigeration system for 10K operation.

A thorough thermodynamic analysis has been completed on the entire three stage refrigerator and is summarized in Sections 2.1 and 2.2. Engineering layout of the gas channels has been completed for the first five layers, the argon and hydrogen refrigeration stages, of the proposed eight layer refrigerator. The physical design and function of this portion of the cooler is described in Section 2.3.

A prototype, single gas, two stage compressor has been designed built and tested. The details of this and the results obtained are described in Section 3.

2.0 Refrigerator Design

During the present reporting period (August 1 to October 15, 1985) the thermodynamic design of the ONR helium refrigerator has been completed. The results of the detailed enthalpy balances for the argon, hydrogen and helium stages are described in Section 2.1. A description of the required operating conditions of the heat exchangers in each stage is included in Section 2.2. Finally the physical description of the argon and hydrogen stages is given in Section 2.3.

2.1 Thermodynamic Analysis

The thermodynamic analysis of the ONR refrigerator proceeds from detailed enthalpy balances of each stage of the device. These balances are solved, one after the other, beginning with the helium stage, then hydrogen and argon taking into account the refrigeration capacity, the thermal masses cooled, the heat leaks present, the enthalpy differences expected in the gas streams and the theoretical heat exchanger efficiencies. The result of these calculations are the gas flowrates required in each stage, and are summarized in the following sections. An overall enthalpy balance for the ONR helium refrigerator is shown in Figure 2.1-1, and a physical schematic of the device is shown in Figure 2.1-2.

2.1.1 Enthalpy Balance - Helium Stage

The enthalpy balance for the helium stage that applies during the transient cooldown period can be written;

$$\dot{m}_{\text{He}} \Delta H_{\text{hg}} = \frac{1}{t} \sum q_i + \sum_j \dot{q}_j \quad (1)$$

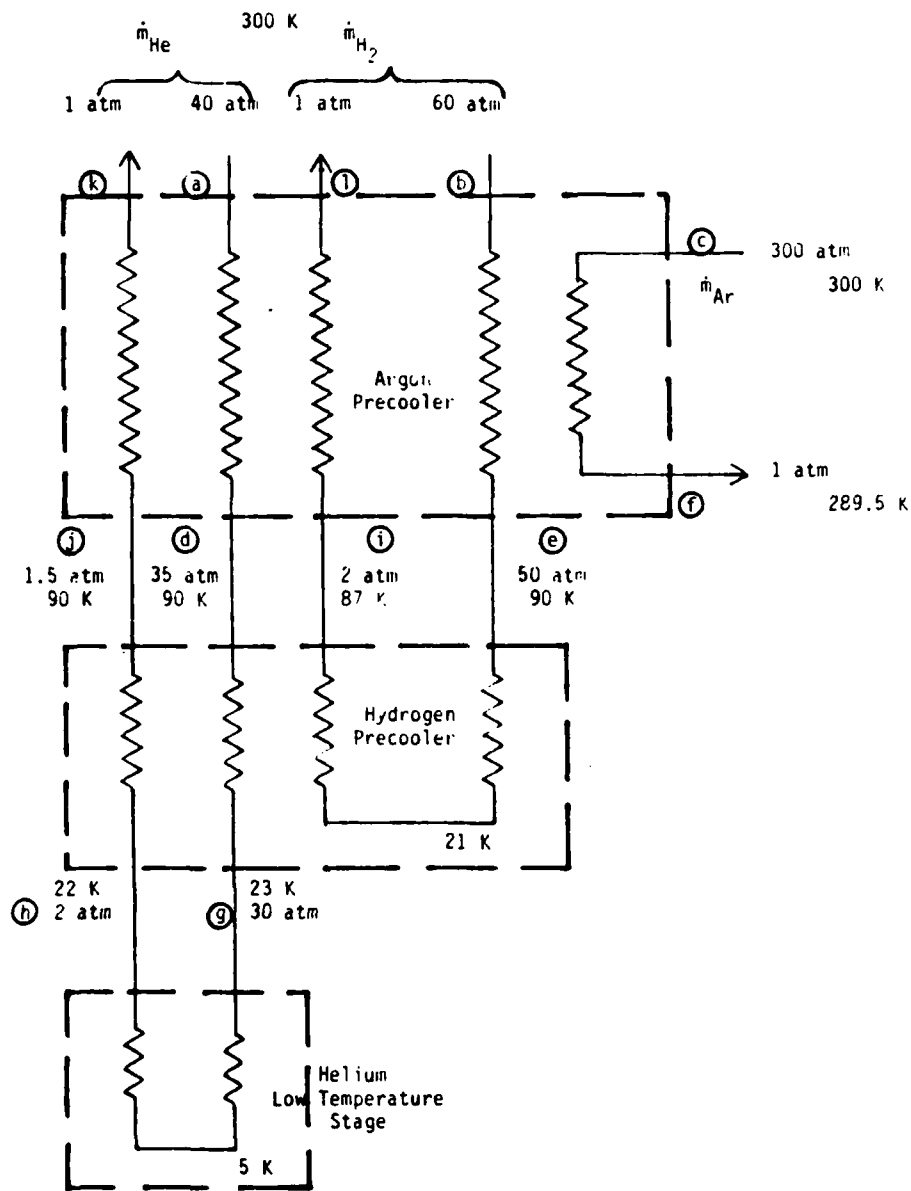

Enthalpy Balance
 for the
 ONR Helium Cooler

Figure 2.1-1

Physical Size and Arrangement
of the Helium Refrigerator

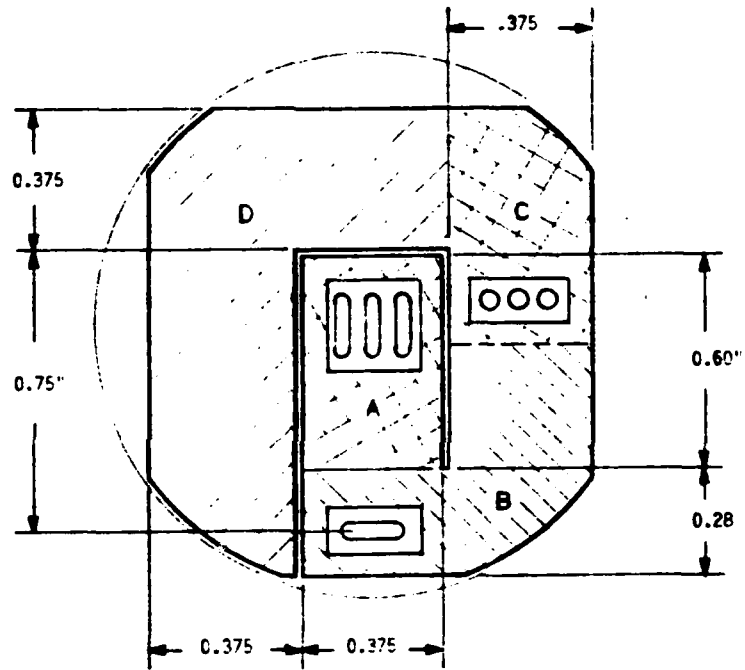

Figure 2.1-2

where the q_i denotes the thermal masses between 23K and 10K, \dot{q}_j denotes the heat leaks, and t is the length of the transient period. The thermal masses and power dissipation terms are tabulated in Table 2.1-1. The thermal mass terms for sensor and refrigerator material are based upon the physical schematic shown in Figure 2.1-2. The heat leak is that caused by thermal conduction through the refrigerator material (glass) between 23K and 10K. The radiation term results from a 300K ambient exposed to the gold flashed surface of the coldstage (emissivity assumed to be 0.02). When the enthalpy balance is solved the dominant term for the helium stage is the required refrigeration at 10K, specified to be 10 milliwatts. The volumetric flowrate of helium based upon a rapid cooldown of three minutes is;

$$\dot{V}_{\text{He}} = 1.3 \text{ liters/min. at STP.}$$

2.1.2 Enthalpy Balances - Hydrogen Stage

The enthalpy balance that applies to the hydrogen stage during the transient cooldown period is given by;

$$\dot{m}_{\text{H}_2} \Delta H_{ie} = \frac{1}{t} \sum_i q_i + \sum_j \dot{q}_j \quad (2)$$

The thermal mass terms (q_i) are taken to be those portions of the refrigerator cooled by hydrogen from 90K to 23K. The power dissipation terms (\dot{q}_j) are due to the conduction heat leak through the refrigerator material, radiation incident on the hydrogen stage and the precooling required by the helium stream. The numerical values of these terms are shown in Table 2.1-1. For this stage there is no single dominant term that determines the refrigerator performance. The refrigerator thermal mass (q_{glass}) and the precooling required by the helium stream (q_{He}) combine to account for most of the heat load in this portion of the device. The result of this balance is a volumetric flowrate of hydrogen of;

$$\dot{V}_{\text{H}_2} = 1.20 \text{ liters/min. at STP.}$$

2.1.3. Enthalpy Balances - Argon Stage

The enthalpy balance that applies to the argon stage during the transient cooldown period is given by;

$$\dot{m}_{\text{Ar}} \Delta H_{fc} = \frac{1}{t} \sum_i q_i + \sum_j \dot{q}_j \quad (3)$$

The thermal mass terms (q_i) represent the entire material of the refrigerator that is cooled from an initial ambient temperature of

Thermal Mass and Power
Dissipation Values Calculated
for Figure 2.1-1

	Helium Stage	Hydrogen Stage	Argon Stage
q_{glass}	$= 4.26 \times 10^{-2}$ joules	$= 4.61$ joules	$= 2.76 \times 10^2$ joules
q_{sensor}	$= 1.49 \times 10^{-2}$ joules	$\dot{q}_{\text{He}} = 8.83 \times 10^{-2}$ watts	$\dot{q}_{\text{H}_2} = 4.82 \times 10^{-1}$ watts
\dot{q}_{load}	$= 1.0 \times 10^{-2}$ watts	$\dot{q}_{\text{radiation}} = 4.95 \times 10^{-3}$ watts	$\dot{q}_{\text{He}} = 2.15 \times 10^{-2}$ watts
$\dot{q}_{\text{radiation}}$	$= 3.52 \times 10^{-3}$ watts	$\dot{q}_{\text{leak}} = 9.57 \times 10^{-3}$ watts	$\dot{q}_{\text{leak}} = 9.14 \times 10^{-2}$ watts
\dot{q}_{leak}	$= 6.19 \times 10^{-4}$ watts		$\dot{q}_{\text{radiation}} = 5.27 \times 10^{-3}$ watts

Table 2.1-1

300K to the steady-state condition at which the boilers are at 90K and a gradient exists across the argon precooler from 90K to the ambient of 300K. The power dissipation terms (\dot{q}_j) are the result of the conduction leak through the refrigerator material, the radiation incident on the refrigerator from the 300K ambient, and the precooling required by the hydrogen and helium streams. The values of these terms are shown in Table 2.1-1. As would be expected for this high temperature stage, the thermal mass term completely dominates this calculation. This is due to the relatively large specific heat of the refrigerator glass at high ambient temperature. The result of this balance is a volumetric flowrate of argon of;

$$\dot{V}_{Ar} = 3.0 \text{ liters/min. at STP.}$$

2.2 Heat Exchanger Operation/Estimates of Required Approach Temperatures

A method of determining the feasibility of the proposed refrigerator design is to calculate the average approach temperature in each heat exchanger section. These calculations use the schematic physical layout shown in Figure 2.1-2 for the allowed heat exchanger area, and the mass flowrate resulting from the enthalpy balances of Section 2.1. The average approach temperatures required for steady-state operation (described by the overall enthalpy balance) is calculated from;

$$\dot{q} = K \frac{A}{d} \Delta T = \dot{m} \Delta H$$

Here we simply say that the precooling achieved in a given section of precooler is equal to the product of the thermal conductivity of the exchanger material (K) divided by the exchanger wall thickness (d) times the area (A) and the temperature difference (ΔT) between the two gas streams.

$$\text{So, } \Delta T_{\text{average}} = \frac{\dot{m} \Delta H d}{KA} \quad (4)$$

where;

- \dot{m} = mass flowrate through the exchanger
- ΔH = change in enthalpy required by the enthalpy balance.
- A = area for heat exchange
- d = thickness of exchanger wall
- K = thermal conductivity of exchanger material of construction

Precooling Stage

Gas Stream	Argon	Hydrogen	Helium
Argon	9.0*		
Hydrogen	3.1	8.2	
Helium	2.4	1.9**	0.6*

Calculated Maximum Approach Temperature[#]
 Required in Precooler Stages
 of the ONR Refrigerator

* high flow calculation based upon 4000 psig operation for fast cooldown.

** assuming .003" interlayer design.

approach temperature = temperature difference between two gas streams shown in narrative.

Table 2.1-2

Table 2.2-1 shows the temperature change that is required in each heat exchanger section of the ONR refrigerator.

For example, in Table 2.2-1 we see that the argon stage must precool the hydrogen stream from the ambient temperature of 300K to approximately 90K. The quantities used in equation (4) above are determined as follows;

- \dot{m}_{H_2} , determined from the enthalpy balance of Section 2.1.2, equals 2.0×10^{-3} gm/sec.
- ΔH , determined from the overall enthalpy balance of Figure 2.1-1, equals 2.88×10^3 joules/gm.
- d , heat exchanger wall thickness, approximately 2.5×10^{-3} cm
- A , heat exchange area available, approximately 4.8 cm^2
- K , thermal conductivity of the heat exchanger material (at approximately 150K). 8×10^{-3} watts/cm K

With these values, equation (4) yields, $\Delta T_{\text{average}} = 3.1$ K. In a similar manner the required approach temperature can be calculated for each section of the cooler. The results of these calculations are shown in Table 2.2-2.

2.3 Physical Design/Function

During this reporting period, the design of the first five layers of the ONR helium refrigerator have been completed. The gas channels have been layed-out at 25x true scale, rubilith has been made of these patterns, and then photo-reduced. The resulting "true size" layer patterns are shown in Figure 2.3-1. In each of these layers the gas channels have been sized to accommodate the gas flowrate calculated in Section 2.1, and to produce the pressure drop required in each section of the device. The theoretical design of the helium stage has been completed and the detailed layout of these last three layers will begin soon.

The operation of each of the first five layers can best be understood with reference to Figure 2.3-1. Layers 1, 2, and 3 comprise the argon stage. As shown schematically in Figure 2.1-2 the gas channels of this stage wrap approximately two-thirds of the way around the outer portion of the 1.5" diameter disk of the cooler. High pressure argon gas enters layer 2 through a small inlet hole located at approximately 8 o'clock. The warm gas circulates clockwise in this layer and is precooled with only a slight pressure drop. Upon reaching approximately 2 o'clock in this layer, the argon undergoes its first expansion reaching a pressure of approximately 20 atmospheres at point "A". At this point the gas stream splits, the major portion passes downwards into layer 1. Once in layer 1 this stream circulates counter-clockwise and exits the device through the exhaust hole in layer 1. The smaller

Precooling Stage

Gas Stream	Argon	Hydrogen	Helium
Argon	300 → 220	—	—
Hydrogen	300 → 90	90 → 45	—
Helium	300 → 90	90 → 23	23 → 13

Temperature Change Required
in Each Stage of the
ONR Helium Refrigerator

Table 2.2-1

Layer #5

Hydrogen low pressure exhaust

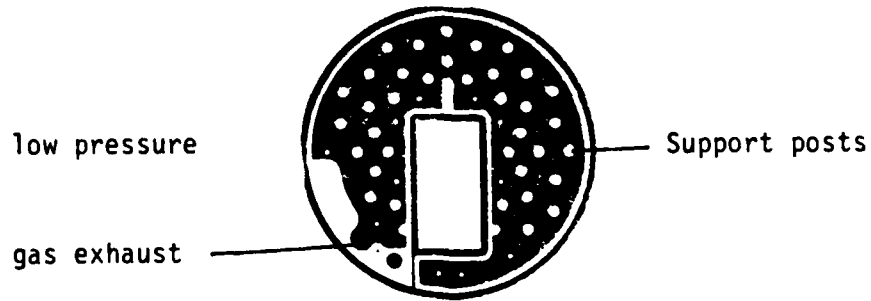

Layer #4

Hydrogen high pressure inflow

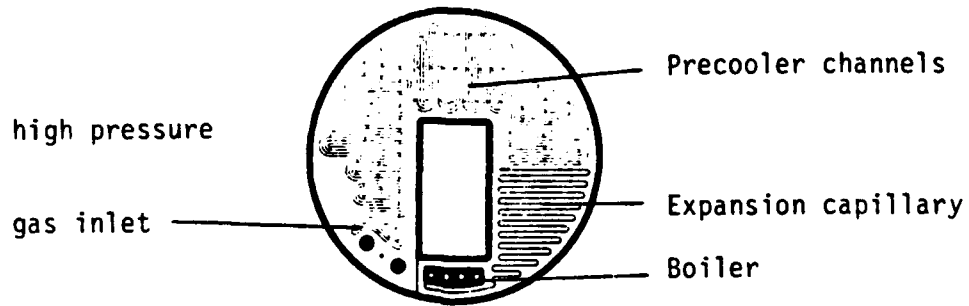

Layer #3

Argon low pressure exhaust

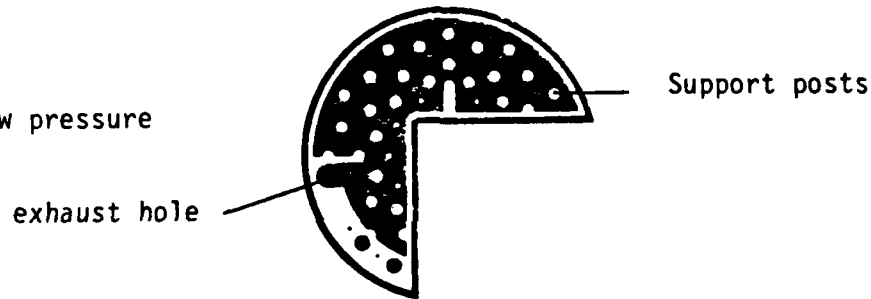

Layer #2

Argon high pressure inflow

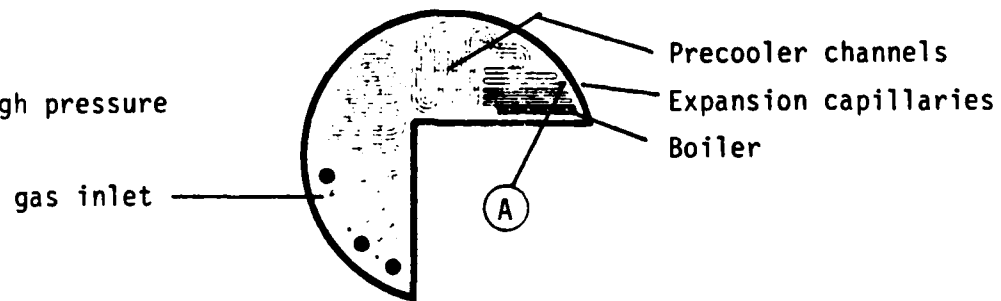

Layer #1

Argon high pressure exhaust

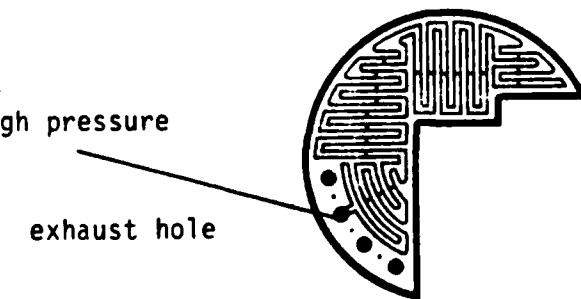

Detailed Physical Layout

Figure 2.3-1

fraction of the argon stream remains in layer 2, undergoes a second expansion and liquifies in the argon boiler. The liquid/gas mixture produced in the boiler of layer 2 passes upward into layer 3, boils and circulates counter-clockwise, finally exiting the cooler through the exhaust hole in layer 3. By the arrangement of gas channels in adjacent layers, a counter-current heat exchanger is produced. The warm stream in layer 2 is "sandwiched" between two cold streams in layers 1 and 3.

Layers 4 and 5 comprise the hydrogen stage of the device. Its operation is similar to that of the argon stage just described; however the gas channels are sized for the required hydrogen flowrate and a Hampson cycle is used. The gas channels of this stage wrap "once around" the outside of the refrigerator disk. As can be seen clearly from Figure 2.3-1, the hydrogen capillary and boiler extend beyond the end of the argon stage below; thus providing thermal isolation for the hydrogen boiler (at 23K) from the argon boiler (at 90K). High pressure (60 atm) hydrogen gas enters layer 4 through a small hole located at 7 o'clock in that layer. It circulates clockwise in the pre-cooler channels of that layer and is cooled while undergoing little pressure drop. After passing over the argon boiler and reaching 90K, the hydrogen stream expands and liquifies in the boiler located at 6 o'clock in layer 4. The entire gas/liquid stream passes upward into layer 5. Here the cold stream passes counter-clockwise through the low pressure heat exchanger and finally exits the device through the large hole in layer 5.

At present the center of the refrigerator disk is not used. The helium stage will occupy all the area of the disk. The final heat exchanger, expansion capillary and boiler (10K) of this stage will extend beyond the hydrogen boiler (23K) into the presently unused center portion of the refrigerator disk.

3.0 Compressor

A prototype, single gas (Air), two stage compressor has been designed, built and tested. Its design was based on the design principles and mode of operation outlined in the first progress report.

An electrically driven hydraulic pump delivers hydraulic fluid through an electronically timed, four-way valve to a double acting, double rod hydraulic cylinder which drives the first and second stage pistons of the pneumatic circuit. The return fluid, after passing back through the four-way valve is cooled through an air-cooled radiator, before returning to the reservoir. The cylinder bore and stroke were sized to give a cycle speed of fourteen cycles per minute. The layout of the system is shown schematically in Figure 3.0.

3.1 Component Description

The key components of the compressor are summarized below:

3.1.1 Hydraulic Cylinder

Double acting, double rod O-ring sealed piston in aluminum housing.

3.1.2 First Stage Cylinder

Aluminum cylinder 2.50" diameter, 2.00" stroke, bearing surface hard anodized and honed to a 2-4 micro-inch finish.

3.1.3 Second Stage Cylinder

Aluminum cylinder 0.75" diameter, 2.00" stroke, bearing surface hard anodized and honed to a 2-4 micro-inch finish.

3.1.4 Seals

Single, spring loaded lip seal of filled teflon for each piston.

3.1.5 Pistons

Aluminum pistons anodized and teflon coated.

3.1.6 Valves

Cartridge type brass check valves in stainless steel housing.

3.1.7 Intercoolers

Stainless steel tubing intercoolers.

3.2 Design Philosophy

The purpose of building the prototype was to obtain in as short a time as possible, preliminary results on the performance of all the key components under normal operating circumstances. Off-the-shelf components were used where ever possible.

The design of the piston seals called for three sealing rings per piston, however, only single seals were installed to allow measurements of seal wear at an accelerated rate.

Engineering drawings have been completed of the cylinders, piston and valve assemblies. These have been fabricated and assembled and put through preliminary tests.

3.3 Performance

The prototype compressor met the design goal delivering 2.0 l/min (STP) at 2000 psi outlet pressure. At zero flow the outlet pressure

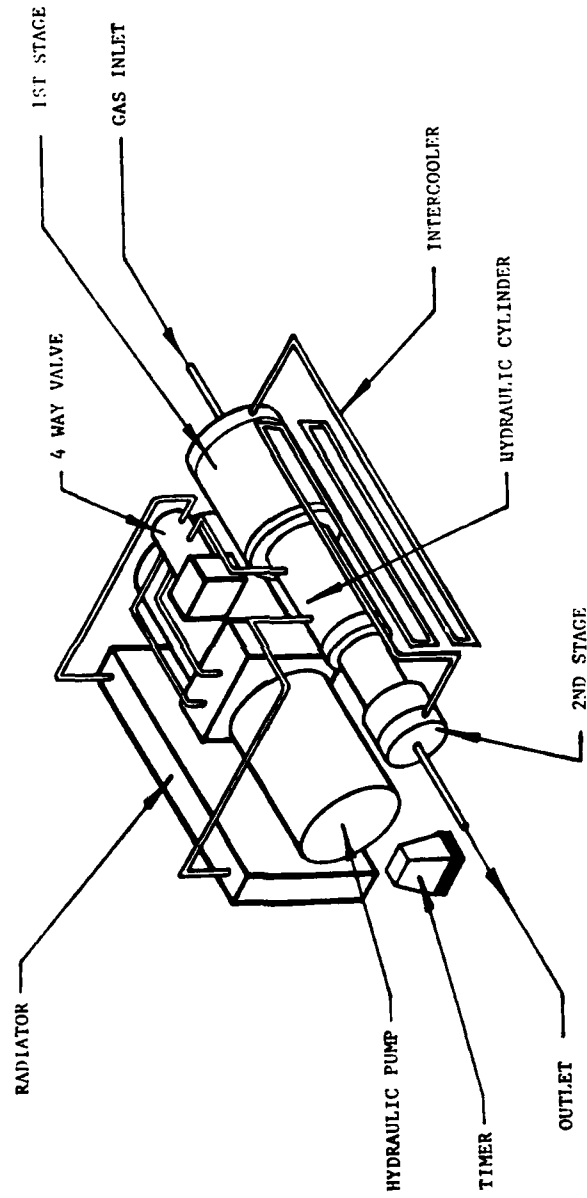

Compressor Schematic

Figure 3.0

exceeded 3200 psi, limited by the hydraulic pressure relief valve setting.

Approximately 100 hours of testing of the compressor was completed on dry air with a moisture content below 1ppm. The compressor was then operated in a closed cycle mode with a MMR microminiature refrigerator and gas drier in the circuit. The test was interrupted periodically to inspect the check valves, sealing surfaces and hydraulic surfaces. A total of approximately 370 hours of operation has been logged.

3.4 Results and Discussion

The only major problem encountered was leakage of hydraulic fluid past the rod seals on the hydraulic cylinder. The cylinder used, was a low cost, low pressure cylinder which was available off-the-shelf. It was operated at 800 psi which is close to its maximum rating. Discussions with the manufacturer indicates that use of a higher rated cylinder and one with double rod seals will eliminate this problem.

One failure did occur with a high pressure seal. However, examination of the seal indicates that it was probably nicked during assembly and failed to seat upon being pressurized. The seal had clearly not worn significantly but had folded over and broken.

The prototype has proved the general validity of the approach. The necessary changes are being made in the choice of hydraulic cylinder and some redesign is being made of the end plates to strengthen the support of the valve assemblies. A second prototype will then be assembled and operated over an extended period to check on the wear of the sealing rings and check valves before proceeding with the addition of the second and third gas circuits.

4.0 Objectives of the Next Reporting Period

During the next reporting period it is expected that the following tasks will be completed:

Experimental

1. The first five layers of the refrigerators will be fabricated. Figure 4.0-1 shows an example of the "two by two" step and repeat patterns that are required for the photo-resist etching process. The manufacture of the glass components for the first five layers will begin with this step.
2. Each stage (argon and hydrogen) will be assembled independently and flow tested.
3. The argon stage will be tested for full cryogenic performance with high pressure gas.

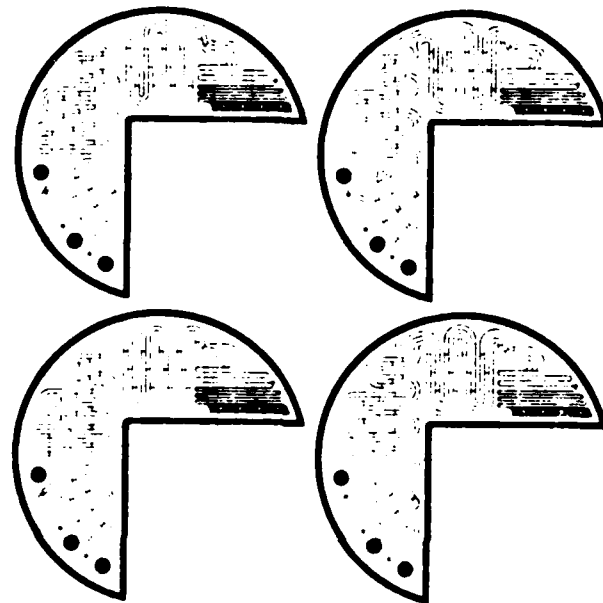

Photomask Step and Repeat
used for Prototype
Manufacture

Figure 4.0-1

4. Once the argon stage is found to operate properly, the hydrogen stage will be attached and the assembly will be operated with high pressure gas.
5. A second single gas prototype compressor will be completed and test on it will be initiated. This will then be used for tests of each of three gases prior to the fabrication of the three gas unit.

Theoretical

1. A full layout of the helium stage will be completed.
2. Photo-masks will be made to prepare for fabrication of this stage.

5.0 Glossary

The variables used in the calculations are defined as follows:

- q = thermal mass, joules
- \dot{q} = power watts
- m = mass grams
- \dot{m} = mass flowrate, gm/sec
- H = enthalpy, joules/gr
- K = thermal conductivity, watts/cm K
- t = thickness, cm
- r = radius, cm
- R = electrical resistance, ohms
- L = The Lorentz No. = 2.45×10^{-8} (volts/K)²
- T = temperature, K
- C = refrigeration capacity, watts
- ΔH = enthalpy difference joules/gr
- $\Delta T(t)$ = time dependent temperature difference (K)
- ΔT_0 = initial temperature difference (K)
- η = thermal diffusivity (cm²/sec)
- ℓ = characteristic length (cm)
- w(ℓ) = width of refrigerator disk as function of length
- V = volumetric flowrate at STP, liter/min
- μ = Joule-Thomson Coefficient (K/atm)
- V = volume, cm³
- ρ = density, gm/cm³
- $c_p(T)$ = temperature dependent specific heat, (joules/grm K)
- tc = time, min.
- d = diameter, cm
- σ = Stefan Boltzmann Constant, 5.67×10^{-12} watts/cm² K⁴
- ϵ = emissivity
- ρ_e = electrical conductivity, (ohm cm)⁻¹

R = gas constant 8.2×10^{-2} , (liter atm/g mole K)
MW = molecular weight, (gm/g mole)
P = exhaust pressure, (atm)
 α = refrigerator flow coefficient, (liter/atm min)
h = heat transfer coefficient, watts/cm² K

END

FILMED

12-85

DTIC