

MICROCOPY RESOLUTION TEST CHART
NATIONAL BUREAU OF STANDARDS-1963-A

12

COORDINATED SCIENCE LABORATORY

AD-A161 350

**AN EXPERIMENTAL STUDY OF
DIELECTRIC ROD ANTENNAS
FOR MILLIMETER-WAVE
IMAGING APPLICATIONS**

S. H. DORAN
R. MITTRA

DTIC FILE COPY

DTIC
ELECTE
NOV 20 1985
S
Y
E
D

This document has been approved
for public release and sale its
distribution is unlimited.

UNIVERSITY OF ILLINOIS - URBANA, ILLINOIS

11 18-85 002

Unclassified

SECURITY CLASSIFICATION OF THIS PAGE

AD-A161350

REPORT DOCUMENTATION PAGE

1a. REPORT SECURITY CLASSIFICATION Unclassified		1b. RESTRICTIVE MARKINGS None	
2a. SECURITY CLASSIFICATION AUTHORITY N/A		3. DISTRIBUTION/AVAILABILITY OF REPORT Approved for public release, distribution unlimited.	
2b. DECLASSIFICATION/DOWNGRADING SCHEDULE N/A			
4. PERFORMING ORGANIZATION REPORT NUMBER(S) R-report # 1037 UIIU-ENG 85-2212		5. MONITORING ORGANIZATION REPORT NUMBER(S) N/A	
6a. NAME OF PERFORMING ORGANIZATION Coordinated Science Lab University of Illinois	6b. OFFICE SYMBOL (If applicable) N/A	7a. NAME OF MONITORING ORGANIZATION Office of Naval Research	
6c. ADDRESS (City, State and ZIP Code) 1101 W. Springfield Avenue Urbana, IL 61801		7b. ADDRESS (City, State and ZIP Code) 800 N. Quincy Street Arlington, VA 22217	
8a. NAME OF FUNDING/SPONSORING ORGANIZATION ONR	8b. OFFICE SYMBOL (If applicable) N/A	9. PROCUREMENT INSTRUMENT IDENTIFICATION NUMBER Contract #1-5-40213	
8c. ADDRESS (City, State and ZIP Code)		10. SOURCE OF FUNDING NOS.	
		PROGRAM ELEMENT NO.	PROJECT NO.
		TASK NO.	WORK UNIT NO.
11. TITLE (Include Security Classification) An Experimental Study of Dielectric Rod Antennas for Millimeter-Wave Imaging Applications			
12. PERSONAL AUTHOR(S) S. H. Doran and R. Mittra			
13a. TYPE OF REPORT Technical	13b. TIME COVERED FROM _____ TO _____	14. DATE OF REPORT (Yr., Mo., Day) April 1985	15. PAGE COUNT 20
16. SUPPLEMENTARY NOTATION N/A			
17. COSATI CODES		18. SUBJECT TERMS (Continue on reverse if necessary and identify by block number)	
FIELD	GROUP	SUB. GR.	
		Dielectric Antennas; Millimeter and Submillimeter Waves; Imaging Radar	
19. ABSTRACT (Continue on reverse if necessary and identify by block number) In this report, the results of an experimental investigation of dielectric antennas for application in an imaging radar at millimeter wavelengths are presented. Several designs for the antenna were tested for use at 81 or 220 GHz and critical design features for these antennas were studied. A simple design for an imaging radar using dielectric antennas was also implemented and field maps were obtained for a series of simple test objects.			
20. DISTRIBUTION/AVAILABILITY OF ABSTRACT UNCLASSIFIED/UNLIMITED <input type="checkbox"/> SAME AS RPT. <input type="checkbox"/> DTIC USERS <input type="checkbox"/>		21. ABSTRACT SECURITY CLASSIFICATION	
22a. NAME OF RESPONSIBLE INDIVIDUAL	22b. TELEPHONE NUMBER (Include Area Code)	22c. OFFICE SYMBOL	

AN EXPERIMENTAL STUDY OF DIELECTRIC ROD
ANTENNAS FOR MILLIMETER-WAVE
IMAGING APPLICATIONS

S. H. Doran and R. Mittra

Electrical & Computer Engineering Department
University of Illinois
Urbana, IL 61801

Accession For	
NTIS GRA&I	<input checked="" type="checkbox"/>
DTIC TAB	<input type="checkbox"/>
Unannounced	<input type="checkbox"/>
Justification	
By _____	
Distribution/	
Availability Codes	
Dist	Avail and/or Special
A-1	



The work reported in this paper was supported by the Joint Service Electronics Program under Contract No. N00014-84-C-0149.

TABLE OF CONTENTS

	Page
I. INTRODUCTION	1
II. EXPERIMENTAL STUDY OF IMAGING ANTENNAS FOR MILLIMETER-WAVE APPLICATIONS	3
III. CONCLUSIONS	17
LIST OF REFERENCES	19

I. INTRODUCTION

As frequencies increase into the millimeter-wave range, the use of low-loss dielectric components becomes more prevalent. The development of dielectric guiding media and integrated circuits has created a need for additional dielectric components. It would be desirable to develop an efficient antenna made of the same dielectric material that could be easily integrated with the other components. Literature on the design and performance of such antennas, however, is severely limited. In this investigation, the design criterion and the performance of several millimeter-wave dielectric rod antennas are discussed. Also, the antenna's performance is observed operating as a component in an imaging radar system.

Some research has been completed on the coupling of dielectric and metal components [1]. Establishing a travelling wave along a dielectric rod through some means of transition from a metal waveguide and then perturbing the wave by either a tapering of the rod or periodic discontinuities have been an effective design recipe for rod antennas [2], [3]. However, merely scaling the microwave antenna designs to millimeter-wave dimensions is often ineffective. By experimentally examining some antennas in the millimeter-wave range, we hope to gain an understanding of the important design factors and performance characteristics of these antennas. One such study of dielectric rod antennas at

76-80 GHz was completed recently [4]. Chang concluded that the design of the transition portion of the antenna was arbitrary and observed that various designs of the radiating end performed similarly.

II. EXPERIMENTAL STUDY OF IMAGING ANTENNAS FOR MILLIMETER-WAVE APPLICATIONS

To determine if the antenna principles design outlined in the last section applied to other operating frequencies or antenna designs, four antennas were constructed and tested at two frequencies.

The table top radar systems were assembled to aid in the study of the antennas. Both the 81 GHz and 220 GHz sources were low power, continuous-wave systems, radiated through high gain horns. The receivers employed were diode detectors, providing amplitude information only. Component diagrams of the 81 GHz and 220 GHz sets are shown in Figures 1 and 2.

All antennas tested were made of Rexolite (dielectric constant = 2.53) and shaped in rectangular rods with a .122 x .061 inch cross section. The rods were inserted into a rigid, open-ended E-band waveguide and used on the receive end only.

A variety of antenna designs was tested and compared to determine the critical features of their shape affecting radiation efficiency. Figure 3 shows the shapes and terms describing the shapes of the antennas investigated. Experiments were conducted by mounting the antenna-equipped waveguide on the center of a turntable, then illuminating the antenna with either of the two high frequency sources. Gain of the antenna was recorded versus aspect angle of the antenna, as the turntable was rotated.

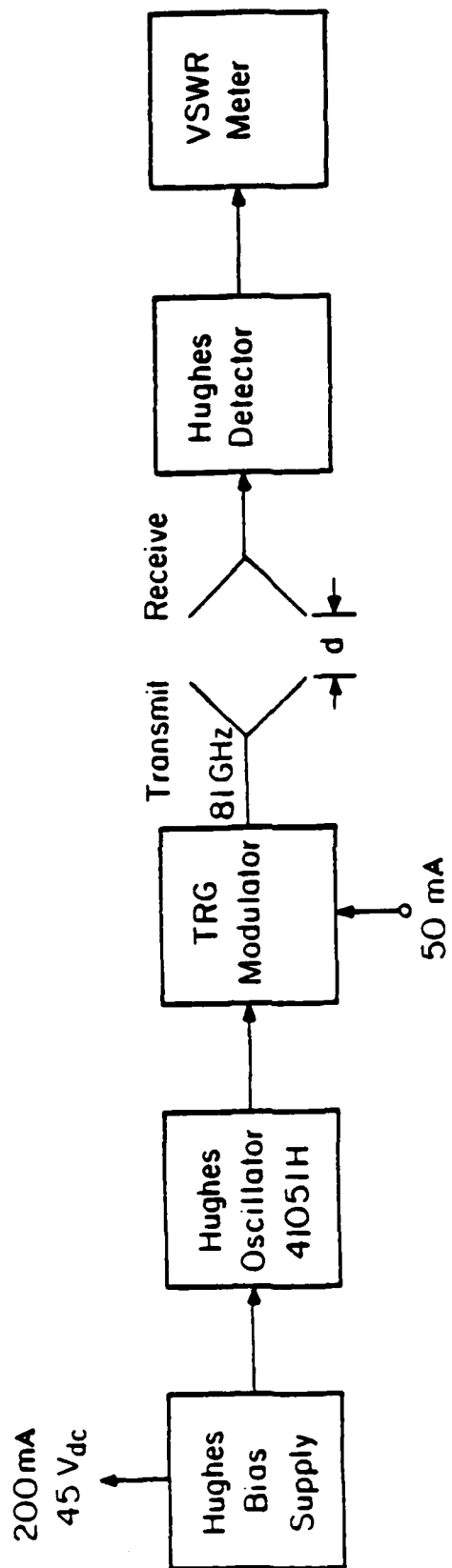

Figure 1. 81 GHz Radar System.

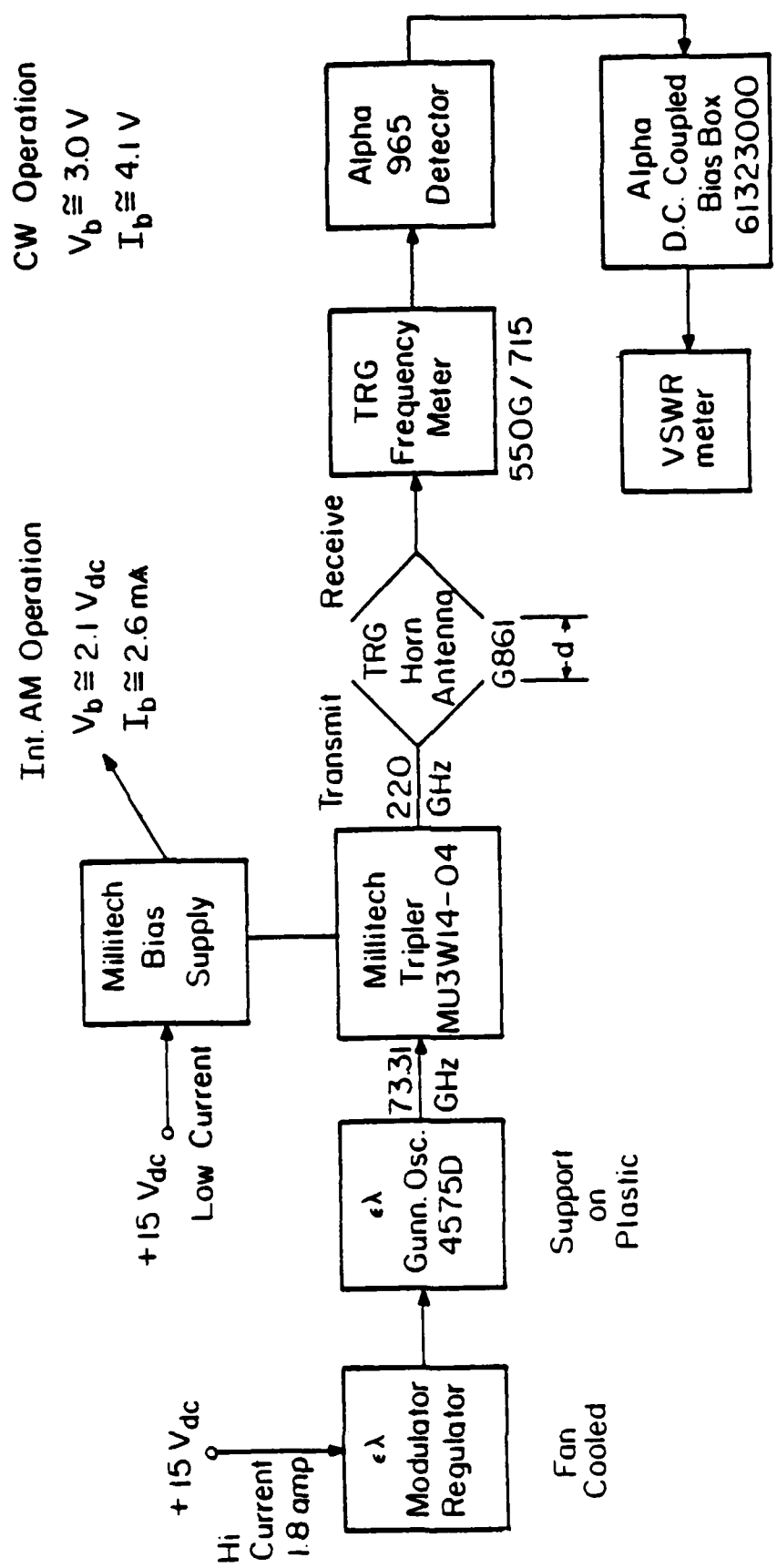

Figure 2. 220 GHz Radar System.

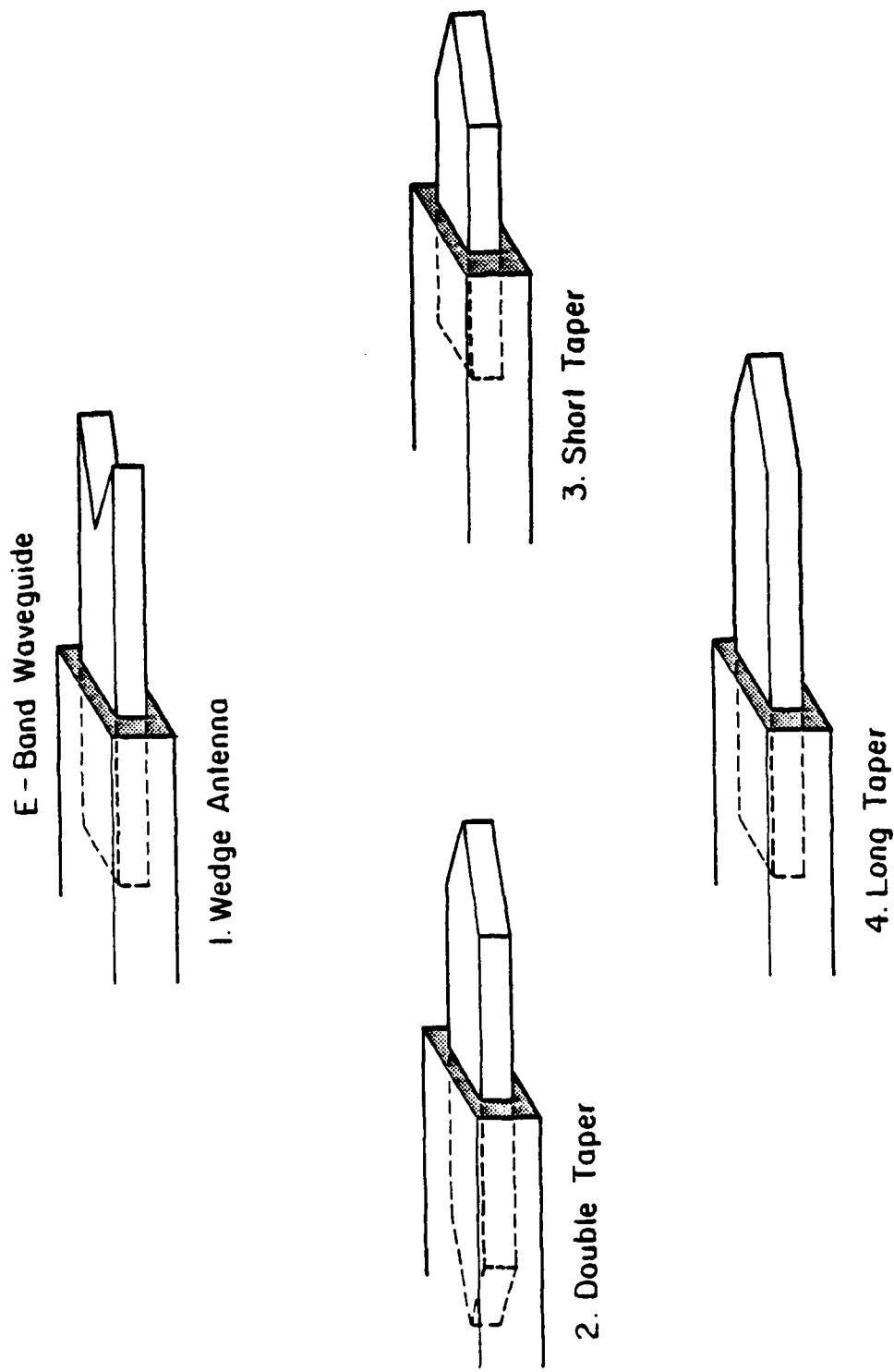

Figure 3. Test Antenna Shapes.

The rods were designed to fit the E-band waveguide used at 81 GHz. For experiments conducted at 220 GHz, the same rods were used with a tapered waveguide transition inserted between the antenna and the detector. Relative gain levels for experiments at each frequency were very similar. The results at 220 GHz are shown in Figure 4. The wedge antenna had the highest gain of all antennas tested, and was the only antenna to perform better than an empty waveguide. These results appear to be consistent with Chang's findings. The most efficient antenna of those tested had an abrupt transition end, the type of transition that theory would tell us would be most reflective [5]. Zucker [6] noticed that reflection takes place at abrupt discontinuities, and smooth transitions are required to establish a surface wave on the antenna, or to effectively radiate energy. These principles appear to be less important at the transition portion of the antenna at millimeter wavelengths. The antenna with a tapered transition was the least effective of the antennas investigated.

The critical design features of these antennas are the lengths of the antenna inside and outside of the waveguide and the shape of the radiating end. By altering the distance, each of the test antennas was inserted into the waveguide; a variance in the gain of up to 10 dB was observed. The difference in performance of the short and long tapered antennas also points out the importance of length in the design of these antennas. A

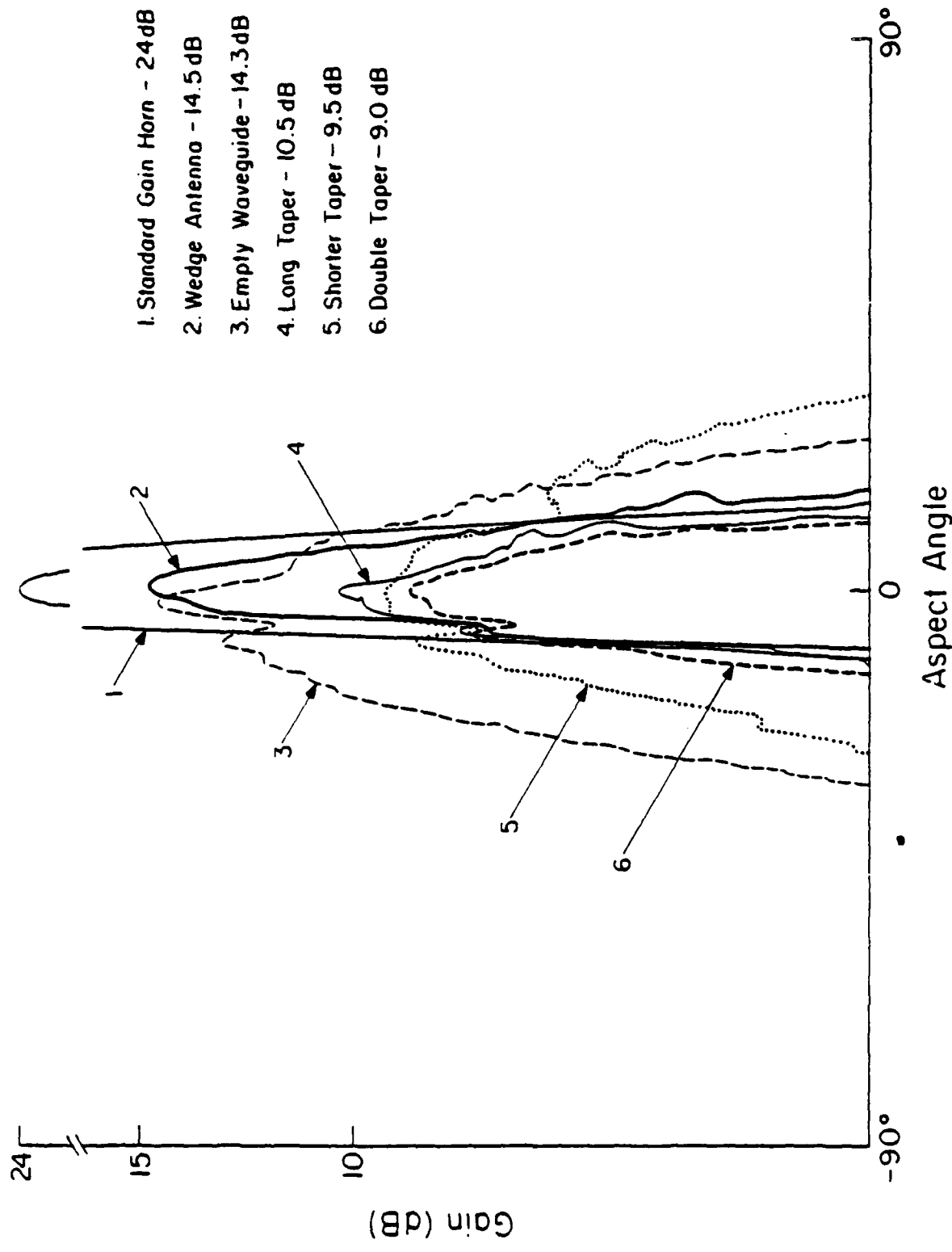

Figure 4. 220 GHz Antenna Test Results.

comparison of the wedge and tapered design antennas in Figure 4 exemplifies the significance of the radiating end design.

Millimeter-wave radars have many popular military and civilian applications. Their relatively high resolutions and abilities to operate at night make terrain imaging one of the more important aspects of these applications. The design of antennas for such systems has been studied by many authors [7], [8]. A simple design of an imaging radar using a dielectric rod antenna is presented and discussed in this section.

In order to obtain "terrain" images from the low power sources available, a lens had to be made to focus the energy reflected off the target. This would create an image intense enough to be detected and small enough to be scanned.

Three dielectric lenses were made so that one could be found suitable for use in imaging experiments. The lenses were made from Rexolite, TPX and High Density Polyethelene and each had different radii of curvature and focal lengths. Each lens was tested by using it to focus the source energy, then scanning the image plane with the receive antenna. The Rexolite lens ($d = 13$ cm, $r_1 = 10$ cm, $r_2 = \infty$) was chosen for use in the imaging radar system since it had the highest gain without distortion. The 81 GHz source was used in the lens' experiments and as the system source in the imaging radar since it had more power available than the 220 GHz source. Figure 5 shows the imaging system as it was set up to test the imagery capability of the radar.

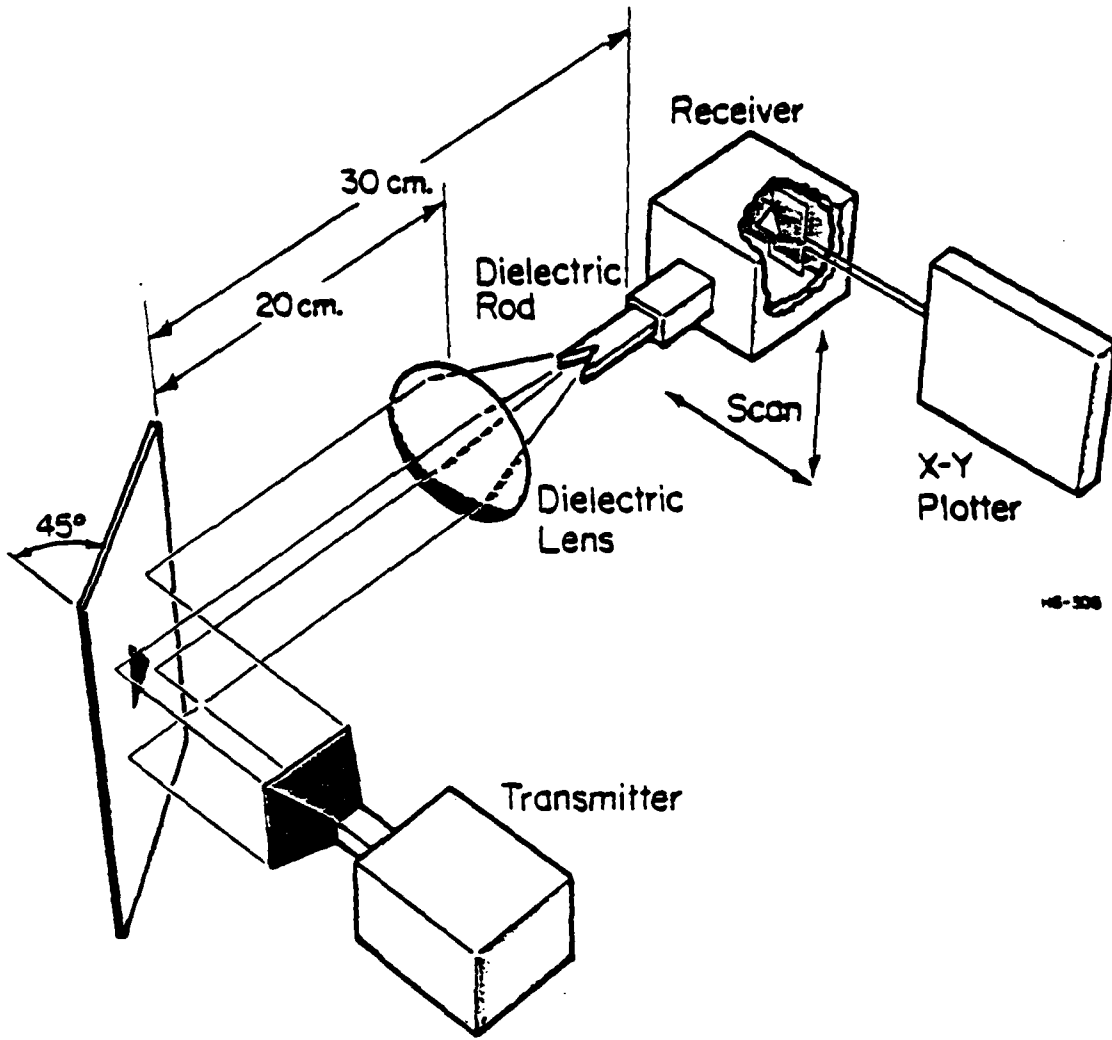

Antenna Range

Figure 5. Imaging Radar System

A resolution test was performed at 81 GHz to determine the imaging system's ability to resolve two points. Thin copper plates were positioned on the object board, then the image plane was scanned with the receive antenna. The image created is transcribed as a plot of receive power versus x-y position. With both plates in the plane of the object board, only the specular reflection of one of the plates would pass through the aperture of the lens and into the image plane. By slightly skewing the position of either plate, the specular reflections off both plates could pass through the lens and show up on the image. Figure 6 shows the image created by two properly angled plates.

Typical radar targets or terrains are much more complex than flat surfaces creating specular reflections. Tetrahedral and dihedral corners, curved surfaces and edge effects are all contributors to complex radar images. The imaging system's ability to detect a variety of these reflections is vital to creating clear images. To determine the sensitivity of the radar, a few changes were made on the test range and a variety of target objects was used. The object board was replaced with a turntable and the receive antenna fixed. Targets were centered on the turntable and the bistatic reflected energy was recorded versus azimuth. Figure 7 shows the radar cross-section measurement of a rectangular block. The contributions to the radar signature come only from the flat sides of the block. A more complex target like that shown in Figure 8 demonstrates the effects of corners in conjunction with flat sides. The spikes

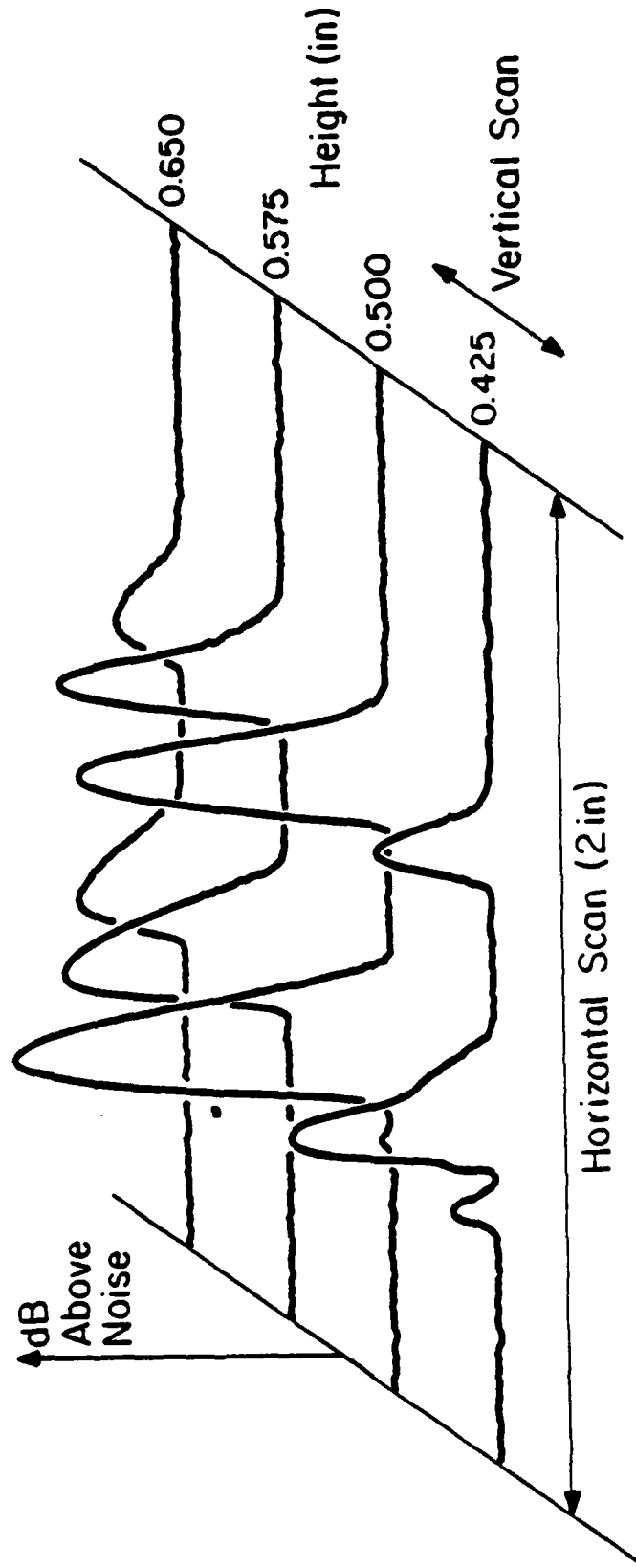

Figure 6. Image Resolution of Two Objects.

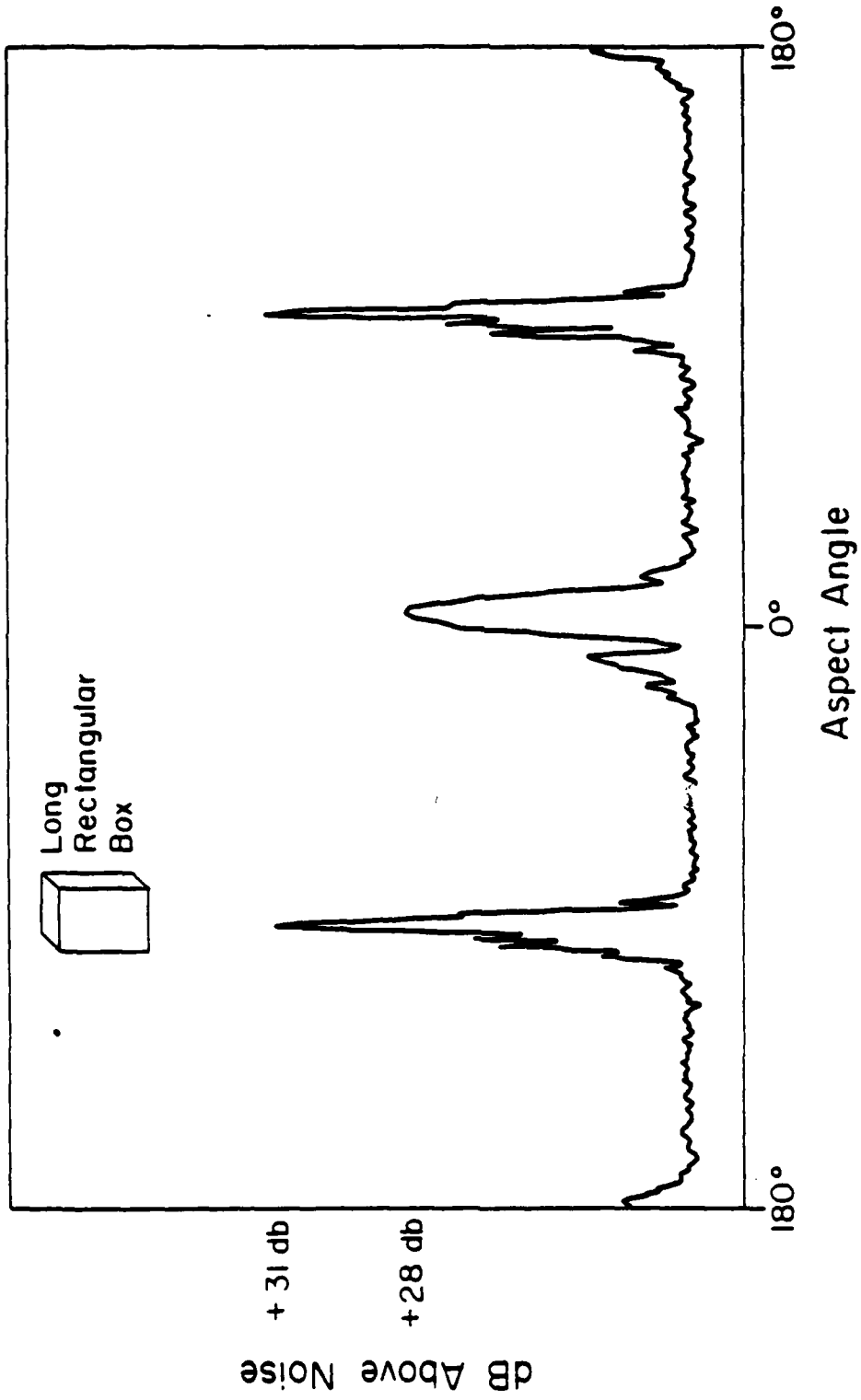

Figure 7. Radar Cross Section: Rectangular Block.

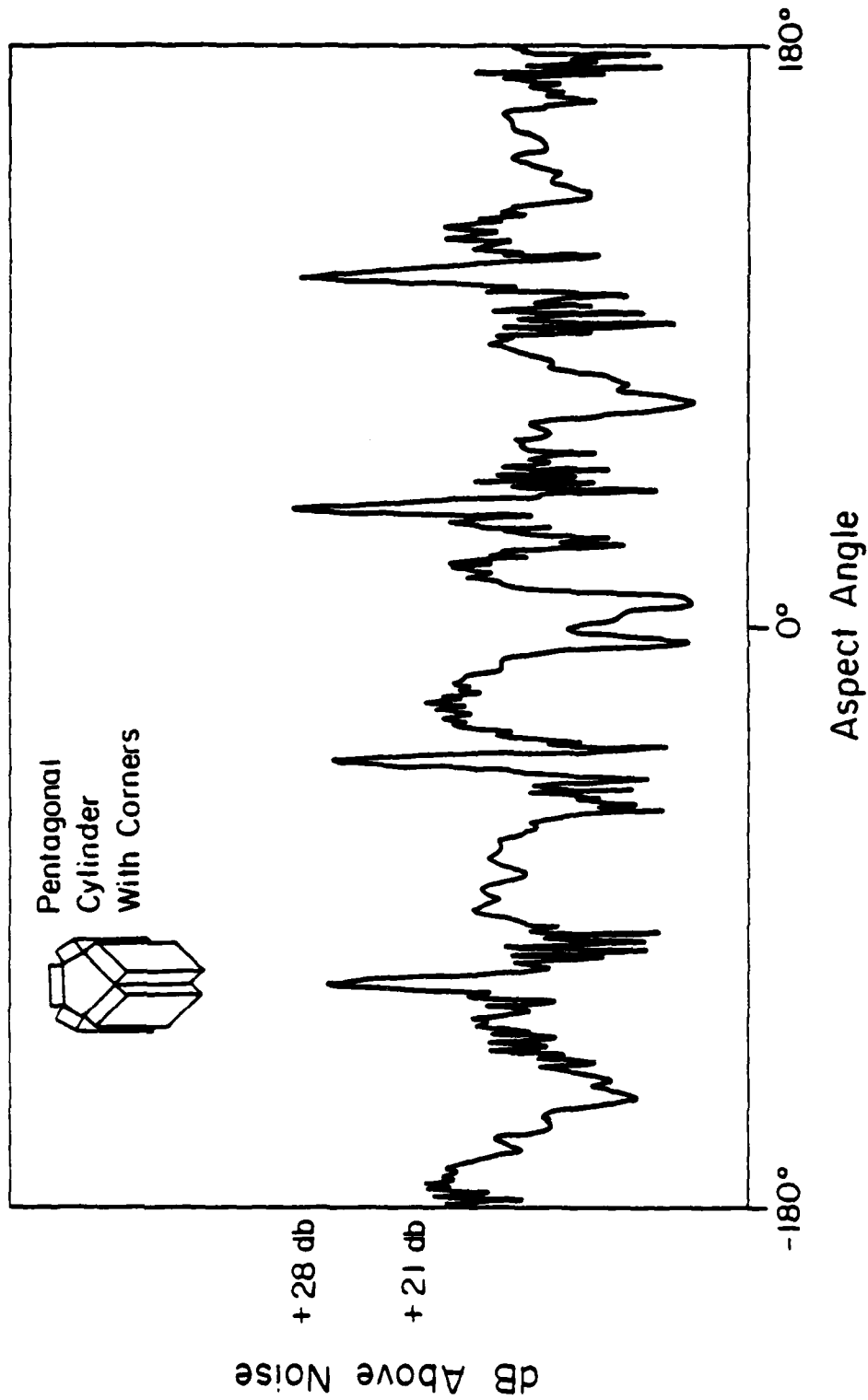

Figure 8. Radar Cross Section: Pentagonal Cylinder.

in the measurement represent the flat side specular returns, but the interference pattern created by the corners between the flat sides is also discernible.

Curved surfaces were examined by observing the radar returns from cylinders of varying radii. Figure 9 makes it clear that the shorter the radius of the cylinder, the more the energy is dispersed and the less energy is received. As the radii of curvature of the cylinders decrease, so does the receive power. A surface that could be considered to have an infinitesimal radius of curvature is an edge or the side of a thin strip. To determine the radar's ability to see edge radiation, a vertical strip of copper was mounted on the turntable and rotated about its long axis. The image created consisted of two spikes from the sides of the strip. To determine if the edges of the strip contributed to the apparently specular image, the edges were coated with a radar absorptive material. The material was made of 2 parts paraffin wax and 1 part extra fine graphite shavings. The mixture was melted, then thoroughly stirred. Application of the wax mixture on several of the previously measured radar targets reduced the known radar cross section 7-10 dB depending on the thickness of the coating. By applying a coating of the radar absorptive material to the edge of the strip, the edge contribution was effectively eliminated from the cross-section measurement. The measurement after the application of the coating showed no perceptible change in the cross-section pattern. The power of the transmitter was simply too low to bring out the edge effects of the uncoated strip.

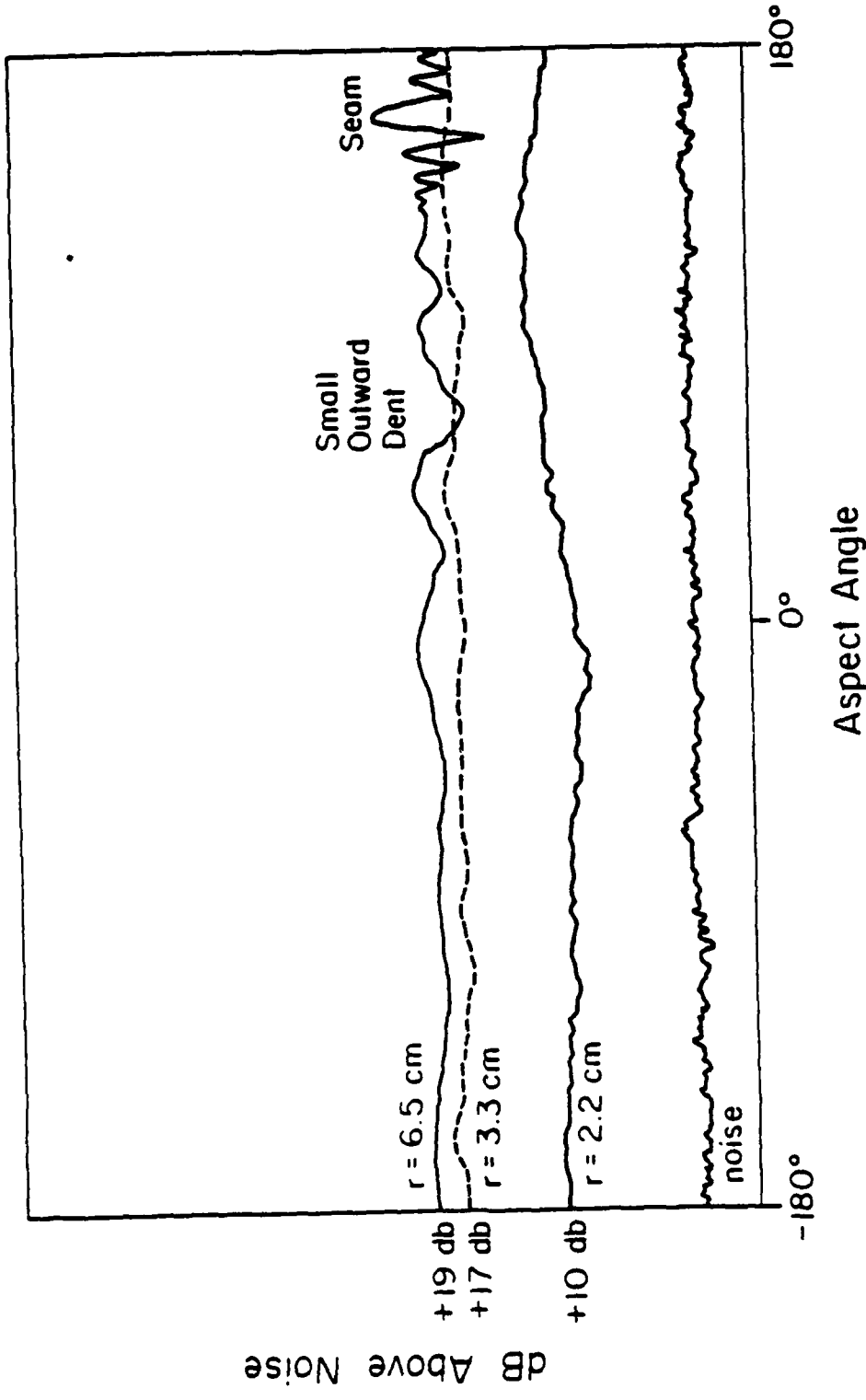

Figure 9. Radar Cross Section: Circular Cylinders.

III. CONCLUSIONS

The experiments on the dielectric rod antennas showed just a few possible design shapes. The wide range in the performance of these antennas makes it clear that the surface of design optimization has just been scratched. The number of design factors (length and shape of transition end, length of rod inside the waveguide, length of rod outside the waveguide, length and shape of radiating end), coupled with the time and difficulty associated with the antenna's manufacture made a thorough analysis of this component a problem beyond the scope of this report. Nevertheless, experiments in this and earlier reports demonstrate that the design of the transition end is not a crucial factor in the overall performance of the antenna. The abrupt transition, the simplest to fabricate, seems to be just as effective as other designs tested. The wedge antenna used in the experiments presented in this report proved to be an effective radiator. However, a more intense study of the dielectric rod antenna should be accomplished to determine the capabilities and limitations of the antenna in millimeter-wave applications.

The scanning system employed to create the images in this paper was an effective scheme to sample the image plane. However, the time delay involved in physically scanning the image plane with one antenna could be a serious limitation in

many dynamic applications. An array of antennas in the image plane could be electronically scanned or could be used as a real-time display of the radar "picture." Such an arrangement of diode detectors would lend itself well to mass production techniques. Use of a photographic "film" sensitive to millimeter waves would be a simple method of producing a static radar image.

Millimeter-wave radar can satisfy many requirements in many applications. Some hardware obstacles do exist, e.g., high-gain antennas and high power RF sources. Recent interest in millimeter waves has stimulated the development of components for this application. Dielectric components such as the rod antenna have been shown to be effective yet simple elements of radar systems. Reduced complexity means reduced costs. Millimeter-wave systems with dielectric components are the vehicles for obtaining high performance with simplified equipment.

LIST OF REFERENCES

- [1]. T. N. Trinh, "Investigation of Metal to Dielectric Waveguide Transition and the Coupling Characteristics of Dielectric Waveguides of Rectangular Cross Section," Technical Report, Coordinated Science Laboratory, University of Illinois, Urbana, IL, November 1980.
- [2]. J. B. Anderson, "Radiation from Surface-wave Antennas," Electron. Lett., Vol. 3, No. 3, pp. 251-252, June 1967.
- [3]. L. B. Felsen, "Radiation From a Tapered Surface-wave Antenna," IRE Trans. Antennas Propagat., Vol. AP-8, pp. 577-586, November 1960.
- [4]. A. Chang and R. Mittra, "Experimental Study of a Dielectric Antenna at the Frequency Range of 76-80 GHz," Technical Report, Coordinated Science Laboratory, University of Illinois, Urbana, IL, October 1983.
- [5]. W. L. Stutzman and G. A. Thiele, Antenna Theory and Design, New York: J. Wiley & Sons, 1981, pp. 192-212.
- [6]. F. J. Zucker, "Surface and Leaky-wave Antennas," Antenna Engineering Handbook, New York: McGraw-Hill, 1961, ch. 16.
- [7]. E. Farr, K. Webb and R. Mittra, "Studies in Fin-Line Antenna Design for Imaging Array Applications," to appear in AEU, 1985.
- [8]. "Development and Test of a 95 GHz Terrain Imaging Radar," Goodyear Aerospace Report, GERA-1987, February 29, 1974.

END

FILMED

1-86

DTIC