

MICROCOPY RESOLUTION TEST CHART
NATIONAL BUREAU OF STANDARDS-1963-A

Chesapeake Bay Tidal Flooding Study

APPENDIX D - SOCIAL AND CULTURAL RESOURCES

APPENDIX E - ENGINEERING DESIGN AND COST ESTIMATES

APPENDIX F - ECONOMICS

20

AD-A161 478

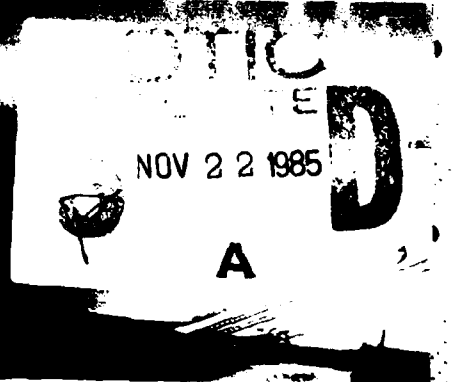
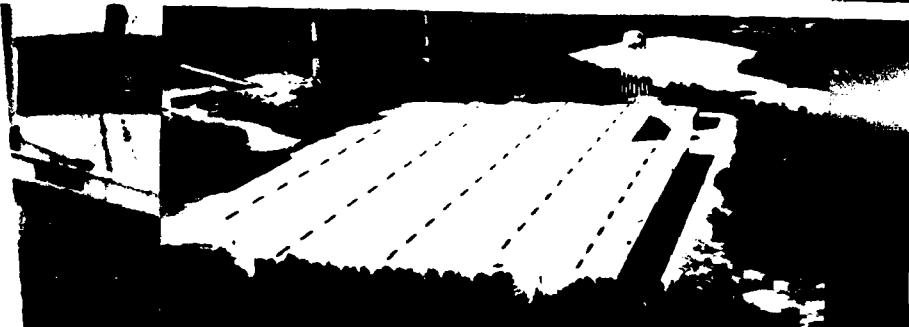
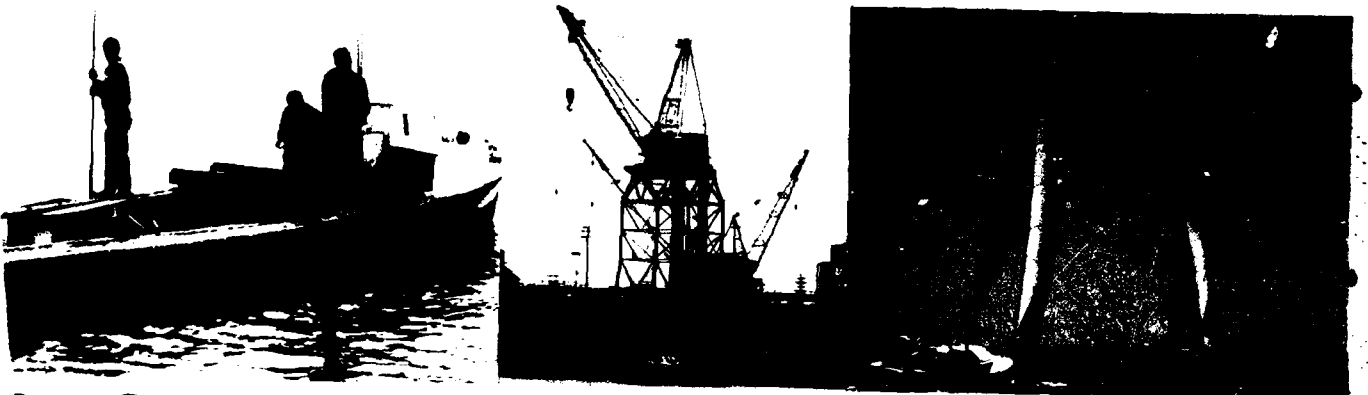

This document has been approved for public release and its distribution is unlimited.

September 1984

UNCLASSIFIED

SECURITY CLASSIFICATION OF THIS PAGE (When Data Entered)

REPORT DOCUMENTATION PAGE		READ INSTRUCTIONS BEFORE COMPLETING FORM
1. REPORT NUMBER CHB-84-T	2. GOVT. ACCESSION NO. AD-A16478	3. RECIPIENT'S CATALOG NUMBER
4. TITLE (and Subtitle) Chesapeake Bay Tidal Flooding Study Main Report , Appendices D through F		5. TYPE OF REPORT & PERIOD COVERED
		6. PERFORMING ORG. REPORT NUMBER
7. AUTHOR(s)	8. CONTRACT OR GRANT NUMBER(s)	
9. PERFORMING ORGANIZATION NAME AND ADDRESS Baltimore District US Army Corps of Engineers, ATTN: NABPL P.O. Box 1715, Baltimore, MD 21203-1715		10. PROGRAM ELEMENT, PROJECT, TASK AREA & WORK UNIT NUMBERS
11. CONTROLLING OFFICE NAME AND ADDRESS Baltimore District US Army Corps of Engineers, ATTN: NABPL P.O. Box 1715, Baltimore, MD 21203-1715		12. REPORT DATE September 1984
		13. NUMBER OF PAGES 780
14. MONITORING AGENCY NAME & ADDRESS (if different from Controlling Office)		15. SECURITY CLASS. (of this report) Unclassified
		15a. DECLASSIFICATION DOWNGRADING SCHEDULE
16. DISTRIBUTION STATEMENT (of this Report) Approved for public release, distribution unlimited		
17. DISTRIBUTION STATEMENT (of the abstract entered in Block 20, if different from Report)		
18. SUPPLEMENTARY NOTES		
19. KEY WORDS (Continue on reverse side if necessary and identify by block number) Chesapeake Bay, structural and non-structural measures, flood forecasting and warning system, tidal flooding, storm surge, flood, flood plain, flood-prone, flood stage, floodwall, estuary, levee, dike, hurricane, tide, riprap, stage-damage relationship		
20. ABSTRACT (Continue on reverse side if necessary and identify by block number) Periodic tidal flooding is a problem that affects all of the Bay's shoreline. Nearly 60 communities around the Bay were identified as having existing or potential flooding problems. Because of their topography and land use patterns, 12 communities were found to be susceptible to significant monetary losses from tidal flooding. Both structural and non-structural measures were considered to reduce or prevent the adverse effects of tidal flooding. Structural measures were generally found		

DD FORM 1 JAN 73 1473 EDITION OF 1 NOV 65 IS OBSOLETE

UNCLASSIFIED
SECURITY CLASSIFICATION OF THIS PAGE (When Data Entered)

UNCLASSIFIED

SECURITY CLASSIFICATION OF THIS PAGE(When Data Entered)

20. ABSTRACT

to be very expensive, have adverse environmental effects, and were less acceptable to local residents. Non-structural solutions were usually less expensive and less environmentally damaging. Combinations of the two were found to be the best alternatives for providing tidal flood protection in the Bay area.

Based on the results of the study, it was recommended that survey scope studies be conducted in the Poquoson, Tangier Island, and Hampton Roads areas of Virginia to include the development and verification of a storm surge model capable of forecasting tidal flood stages and developing stage-frequency relationships.

UNCLASSIFIED

SECURITY CLASSIFICATION OF THIS PAGE(When Data Entered)

Chesapeake Bay Tidal Flooding Study

APPENDIX D - SOCIAL AND CULTURAL RESOURCES

APPENDIX E - ENGINEERING DESIGN AND COST ESTIMATES

APPENDIX F - ECONOMICS

20

[Handwritten signature]	
Date	[Handwritten date]
A-1	

S DTIC
ELECTE
NOV 22 1985
A



**US Army Corps
of Engineers**
Baltimore District



This document has been approved
for public release and sale; its
distribution is unlimited.

September 1984

CHESAPEAKE BAY
TIDAL FLOODING STUDY

APPENDIX D
SOCIAL AND CULTURAL RESOURCES

Department of the Army
Baltimore District, Corps of Engineers
Baltimore, Maryland
September 1984

FOREWORD

This is one of the volumes comprising the final report on the Corps of Engineers' Chesapeake Bay Study. The report represents the culmination of many years of study of the Bay and its associated social, economic, and environmental processes and resources. The overall study was done in three distinct developmental phases. A description is provided below of each study phase, followed by a description of the organization of the report.

The initial phase of the overall program involved the inventory and assessment of the existing physical, economic, social, biological, and environmental conditions of the Bay. The results of this effort were published in a seven volume document titled Chesapeake Bay Existing Conditions Report, released in 1973. This was the first publication to present a comprehensive survey of the tidal Chesapeake and its resources as a single entity.

The second phase of the program focused on projection of water resource requirements in the Bay Region for the year 2020. Completed in 1977, the Chesapeake Bay Future Conditions Report documents the results of that work. The 12-volume report contains projections for resource categories such as navigation, recreation, water supply, water quality, and land use. Also presented are assessments of the capacities of the Bay system to meet the identified future requirements, and an identification of problems and conflicts that may occur with unrestrained growth in the future.

In the third and final study phase, two resource problems of particular concern in Chesapeake Bay were addressed in detail: low freshwater inflow and tidal flooding. In the Low Freshwater Inflow Study, results of testing on the Chesapeake Bay Hydraulic Model were used to assess the effects on the Bay of projected future depressed freshwater inflows. Physical and biological changes were quantified and used in assessments of potential social, economic, and environmental impacts. The Tidal Flooding Study included development of preliminary stage-damage relationships and identification of Bay communities in which structural and nonstructural measures could be beneficial.

The final report of the Chesapeake Bay Study is composed of three major elements: (1) Summary, (2) Low Freshwater Inflow Study, and (3) Tidal Flooding Study. The Chesapeake Bay Study Summary Report includes a description of the results, findings, and recommendations of all the above described phases of the Chesapeake Bay Study. It is incorporated in four parts:

- Summary Report
- Supplement A — Problem Identification
- Supplement B — Public Involvement
- Supplement C — Hydraulic Model

The Low Freshwater Inflow Study consists of a Main Report and six supporting appendices. The report includes:

- Main Report
- Appendix A — Problem Identification
- Appendix B — Plan Formulation
- Appendix C — Hydrology
- Appendix D — Hydraulic Model Test

Appendix E -- Biota
Appendix F -- Map Folio

The Tidal Flooding Study consists similarly of a Main Report and six appendices. The report includes:

Main Report
Appendix A -- Problem Identification
Appendix B -- Plan Formulation, Assessment, and Evaluation
Appendix C -- Recreation and Natural Resources
Appendix D -- Social and Cultural Resources
Appendix E -- Engineering, Design, and Cost Estimates
Appendix F -- Economics

CHESAPEAKE BAY TIDAL FLOODING STUDY
APPENDIX D - SOCIAL AND CULTURAL RESOURCES

TABLE OF CONTENTS

<u>Item</u>	<u>Page</u>
Introduction	D-1
Maryland Flood-Prone Communities	D-1
Cambridge, Maryland	D-1
Demographic Characteristics	D-1
Occupational Distribution	D-3
Income Characteristics	D-3
Educational Characteristics	D-5
Housing Characteristics	D-5
Industrial Employment	D-5
Transportation	D-6
Railroads	D-6
Highways	D-6
Truck Service	D-6
Bus Service	D-6
Water Transportation	D-6
Air Service	D-7
Communications	D-8
Postal Facilities	D-8
Telephone Services	D-8
Radio and Television	D-8
Newspapers	D-8
Utilities	D-8
Electricity and Gas	D-8
Water and Sewerage	D-9
County Services	D-9
Educational Services	D-9
Health Services	D-9
Cultural Institutions	D-10
Libraries and Churches	D-10
Historic Sites	D-10
Land Use	D-10
Existing Land Use	D-10
Future Land Use	D-11
Crisfield, Maryland	D-12
Demographic Characteristics	D-12
Occupational Distribution	D-14
Income Characteristics	D-14
Educational Characteristics	D-14
Housing Characteristics	D-14
Industrial Employment	D-14
Transportation	D-16
Railroads	D-16
Highways	D-16
Truck Service	D-17

TABLE OF CONTENTS (Cont'd)

<u>Item</u>	<u>Page</u>
Bus Service	D-17
Water Transportation	D-17
Air Service	D-17
Communications	D-18
Postal Facilities	D-18
Telephone Services	D-18
Radio and Television	D-18
Newspapers	D-18
Utilities	D-19
Electricity and Gas	D-19
Water and Sewerage	D-19
County Services	D-19
Educational Services	D-20
Health Services	D-20
Cultural Institutions	D-20
Libraries and Churches	D-20
Historic Sites	D-20
Land Use	D-20
Pocomoke City, Maryland	D-21
Demographic Characteristics	D-21
Occupational Distribution	D-22
Income Characteristics	D-23
Educational Characteristics	D-23
Housing Characteristics	D-23
Industrial Employment	D-23
Transportation	D-23
Railroads	D-23
Highways	D-23
Truck Service	D-25
Bus Service	D-25
Water Transportation	D-25
Air Service	D-26
Communications	D-26
Postal Facilities	D-26
Telephone Services	D-26
Radio and Television	D-26
Newspapers	D-27
Utilities	D-27
Electricity and Gas	D-27
Water and Sewerage	D-27
County Services	D-27
Educational Services	D-27
Health Services	D-28
Cultural Institutions	D-28
Libraries and Churches	D-28

TABLE OF CONTENTS (Cont'd)

<u>Item</u>	<u>Page</u>
Historic Sites	D-28
Land Use	D-28
Existing Land Use	D-28
Future Land Use	D-30
Rock Hall, Maryland	D-31
Demographic Characteristics	D-31
Occupational Distribution	D-33
Income Characteristics	D-33
Educational Characteristics	D-33
Housing Characteristics	D-33
Industrial Employment	D-33
Transportation	D-35
Railroads	D-35
Highways	D-35
Truck Service	D-36
Bus Service	D-36
Water Transportation	D-36
Air Service	D-37
Communications	D-37
Postal Facilities	D-37
Telephone Services	D-37
Radio and Television	D-37
Newspapers	D-38
Utilities	D-38
Electricity and Gas	D-38
Water and Sewerage	D-38
County Services	D-38
Educational Services	D-39
Health Services	D-39
Cultural Institutions	D-39
Libraries and Churches	D-39
Historic Sites	D-39
Land Use	D-40
Existing Land Use	D-40
Future Land Use	D-41
St. Michaels, Maryland	D-42
Demographic Characteristics	D-42
Occupational Distribution	D-43
Income Characteristics	D-43
Educational Characteristics	D-45
Housing Characteristics	D-45
Industrial Employment	D-45
Transportation	D-46
Railroads	D-46
Highways	D-46

TABLE OF CONTENTS (Cont'd)

<u>Item</u>	<u>Page</u>
Truck Service	D-47
Bus Service	D-47
Water Transportation	D-47
Air Service	D-47
Communications	D-48
Postal Facilities	D-48
Telephone Services	D-48
Radio and Television	D-48
Newspapers	D-48
Utilities	D-48
Electricity and Gas	D-48
Water and Sewerage	D-49
County Services	D-49
Educational Services	D-49
Health Services	D-49
Cultural Institutions	D-50
Libraries and Churches	D-50
Historic Sites	D-50
Land Use	D-50
Existing Land Use	D-50
Future Land Use	D-51
Snow Hill, Maryland	D-51
Demographic Characteristics	D-51
Occupational Distribution	D-53
Income Characteristics	D-53
Educational Characteristics	D-53
Housing Characteristics	D-53
Industrial Employment	D-53
Transportation	D-55
Railroads	D-55
Highways	D-55
Truck Service	D-56
Bus Service	D-56
Water Transportation	D-56
Air Service	D-56
Communications	D-57
Postal Facilities	D-57
Telephone Services	D-57
Radio and Television	D-57
Newspapers	D-57
Utilities	D-57
Electricity and Gas	D-57
Water and Sewerage	D-57
County Services	D-58
Educational Services	D-58

TABLE OF CONTENTS (Cont'd)

<u>Item</u>	<u>Page</u>
Health Services	D-58
Cultural Institutions	D-58
Libraries and Churches	D-58
Historic Sites	D-59
Land Use	D-59
Existing Land Use	D-59
Future Land Use	D-59
Tilghman Island, Maryland	D-60
Demographic Characteristics	D-60
Occupational Distribution	D-61
Income Characteristics	D-63
Educational Characteristics	D-63
Housing Characteristics	D-63
Industrial Employment	D-63
Transportation	D-63
Railroads	D-63
Highways	D-64
Truck Service	D-64
Bus Service	D-64
Water Transportation	D-65
Air Service	D-65
Communications	D-65
Postal Facilities	D-65
Telephone Services	D-65
Radio and Television	D-66
Newspapers	D-66
Utilities	D-66
Electricity and Gas	D-66
Water and Sewerage	D-66
County Services	D-67
Educational Services	D-67
Health Services	D-67
Cultural Institutions	D-67
Libraries and Churches	D-67
Historic Sites	D-68
Land Use	D-68
Virginia Flood-Prone Communities	D-68
Cape Charles, Virginia	D-68
Demographic Characteristics	D-68
Income Characteristics	D-69
Housing and Municipal Services	D-69

TABLE OF CONTENTS (Cont'd)

<u>Items</u>	<u>Page</u>
Hampton Roads, Virginia	D-70
Demographic Characteristics	D-70
Income Characteristics	D-71
Housing Characteristics	D-71
Employment Characteristics	D-71
Poquoson, Virginia	D-73
Demographic Characteristics	D-73
Occupational Distribution	D-73
Income Characteristics	D-74
Housing Characteristics	D-74
Tangier Island, Virginia	D-75
West Point, Virginia	D-75
Demographic Characteristics	D-75
Occupational Distribution	D-76
Income Characteristics	D-76
Housing Characteristics	D-76
Transportation	D-76
Railroads	D-76
Highways	D-76
Bus Service	D-76
Water Transportation	D-76
References	D-77

LIST OF TABLES

<u>Number</u>	<u>Title</u>	<u>Page</u>
D-1	Tidal Flood-Prone Communities: Maryland and Virginia	D-2
D-2	Historical Population for the U.S., Maryland, Dorchester County, and Cambridge	D-2
D-3	Population Projections for Cambridge and Dorchester County	D-3
D-4	Demographic and Socio-Economic Characteristics for Cambridge, Dorchester County, and Maryland	D-4
D-5	Cambridge 1970 Industrial Employment	D-5
D-6	Cambridge Harbor 1981 Waterborne Commerce	D-7
D-7	Land Use in Cambridge, Maryland	D-10
D-8	Historical Population for the U.S., Maryland, Somerset County, and Crisfield	D-13
D-9	Population Projections for Crisfield and Somerset County	D-13
D-10	Demographic and Socio-Economic Characteristics for Crisfield, Somerset County, and Maryland	D-15
D-11	Crisfield 1970 Industrial Employment	D-16
D-12	Crisfield Harbor 1981 Waterborne Commerce	D-18

LIST OF TABLES (Cont'd)

<u>Number</u>	<u>Title</u>	<u>Page</u>
D-13	Historical Population for the U.S., Maryland, Worcester County, and Pocomoke City	D-22
D-14	Population Projections for Pocomoke City and Worcester County	D-22
D-15	Demographic and Socio-Economic Characteristics for Pocomoke City, Worcester County, and Maryland	D-24
D-16	Pocomoke City 1970 Industrial Employment	D-25
D-17	Pocomoke River 1981 Waterborne Commerce	D-26
D-18	Pocomoke City Land Use	D-29
D-19	Historical Population for the U.S., Maryland, Kent County, and Rock Hall	D-32
D-20	Population Projections for Rock Hall and Kent County	D-32
D-21	Demographic and Socio-Economic Characteristics for Rock Hall, Kent County, and Maryland	D-34
D-22	Rock Hall 1970 Industrial Employment	D-35
D-23	Rock Hall 1980 Waterborne Commerce	D-37
D-24	Rock Hall and Kent County Land Use	D-40
D-25	Historical Population for the U.S., Maryland, Talbot County, and St. Michaels	D-42
D-26	Population Projections for St. Michaels and Talbot County	D-43
D-27	Demographic and Socio-Economic Characteristics for St. Michaels, Talbot County, and Maryland	D-44
D-28	St. Michaels 1970 Industrial Employment	D-45
D-29	St. Michaels 1981 Waterborne Commerce	D-47
D-30	Land Use Within Corporate Limits of St. Michaels	D-51
D-31	Historical Population for the U.S., Maryland, Worcester County, and Snow Hill	D-52
D-32	Population Projections for Snow Hill and Worcester County	D-52
D-33	Demographic and Socio-Economic Characteristics for Snow Hill, Worcester County, and Maryland	D-54
D-34	Snow Hill 1970 Industrial Employment	D-55
D-35	Pocomoke River 1981 Waterborne Commerce	D-56
D-36	Snow Hill Existing Land Use	D-59
D-37	Historical Population for the U.S., Maryland, Talbot County, and Bay Hundred	D-61
D-38	Population Projections for the Tilghman Island Area and Talbot County	D-61
D-39	Demographic and Socio-Economic Characteristics for Tilghman Island, Talbot County, and Maryland	D-62
D-40	Tilghman Island 1970 Industrial Employment	D-64
D-41	Knapps Narrows 1981 Waterborne Commerce	D-65

LIST OF TABLES (Cont'd)

<u>Number</u>	<u>Title</u>	<u>Page</u>
D-42	Northampton County Historical and Projected Population	D-69
D-43	Virginia Department of Planning and Budget Population Projections for Hampton Roads	D-70
D-44	Hampton Roads Comparative Population Projections	D-70
D-45	Hampton Roads Per Capita Income	D-71
D-46	Projected Employment for the Hampton Roads Area	D-72
D-47	OBERS Employment Projections	D-72
D-48	OBERS County Level Employment by Sector for Five-City Area	D-72
D-49	Population Projections for Poquoson, York County, and the Newport-News-Hampton SMSA	D-74
D-50	King William County Historical and Projected Population	D-75

APPENDIX D

SOCIAL AND CULTURAL RESOURCES

INTRODUCTION

The purpose of this appendix is to provide information on the social and cultural features of the communities examined as part of the Chesapeake Bay Tidal Flooding Study. These communities are listed in Table D-1 while the rationale for their inclusion is provided in Appendix A - Problem Identification. Included in this Social and Cultural Resources Appendix are discussions on demographic characteristics, occupational distributions, income, housing, and labor force estimates. Also included are overviews on transportation and communications, municipal services, cultural institutions, and land use for the areas studied.

Much of the information on the demographic, occupational, income, housing, and labor force characteristics for communities with fewer than 2,500 residents was provided by the Fifth Count of the 1970 Census. It should be noted that the data for these smaller communities are subject to variability due to the sampling techniques involved in this count. Change errors may be large because of the numbers involved. Because of this variability the Census Bureau has never published sample data for areas generally smaller than census tracts. Also data on specific sectors of industrial employment such as the fisheries sector are not available from the Fifth Count and therefore had to be addressed on a regional basis. Information on transportation, communications, and municipal services came primarily from Community Economic Inventory reports prepared for the various counties. Land use data for the counties and communities came from the comprehensive plans of the respective communities and counties. Where possible, percentages of major land use categories were provided for the communities.

Demographic projections for the counties and the communities, where possible, were based upon OBERS Series E regional projections. Linear regression techniques based upon historical trends of the population were used to provide estimates for the communities.

Information on archeological sites for the Maryland communities was provided by Mr. Tyler Bastian, the State Archeologist, of the Maryland Geological Survey. The information addressed the communities specifically and covered an area approximately one mile outside the town limits. The Maryland Historical Trust was helpful in providing information on historical structures located within the communities. Though many of these structures are considered to be of historical significance to the Maryland Historical Trust, few have been placed in the National Register of Historic Places.

MARYLAND FLOOD-PRONE COMMUNITIES

CAMBRIDGE, MARYLAND

DEMOGRAPHIC CHARACTERISTICS

Cambridge, Maryland, is the county seat of Dorchester County and is located in the northern part of the County. According to the 1970 Census, the population of Cambridge was 11,595 with a median age of 33.1 years. Of the total population, 48 percent was age 35 years or older. These age figures compare with state figures indicating a median age of 27.1 years with 40 percent of the state population 35 years or greater. Dorchester County

TABLE D-1

TIDAL FLOOD-PRONE COMMUNITIES: MARYLAND
AND VIRGINIA

MARYLAND COMMUNITIES

Cambridge
Crisfield
Pocomoke City
Rock Hall
St. Michaels
Snow Hill
Tilghman Island

VIRGINIA COMMUNITIES

Cape Charles
Hampton Roads
Poquoson
Tangier Island
West Point

figures align themselves closely with those of Cambridge. This is to be expected considering that the population of Cambridge constituted almost 40 percent of the 1970 and 1980 County population. Historical population trends for Cambridge, Dorchester County, the State of Maryland, and the United States are displayed in Table D-2.

TABLE D-2

HISTORICAL POPULATION FOR THE U.S., MARYLAND,
DORCHESTER COUNTY AND CAMBRIDGE
(1940 - 1980)

	<u>1940</u>	<u>1950</u>	<u>1960</u>	<u>1970</u>	<u>1980</u>
UNITED STATES	132,165,000	151,326,000	179,323,000	203,212,000	226,504,825
% change	-	14.5	18.5	13.3	11.5
MARYLAND	1,821,000	2,343,000	3,101,000	3,922,400	4,216,941
% change	-	28.6	32.3	26.5	7.5
DORCHESTER COUNTY	28,006	27,185	29,666	29,405	30,623
% change	-	-2.9	9.1	-0.8	4.1
CAMBRIDGE	10,102	10,351	12,239	11,595	11,703
% change	-	2.4	18.2	-5.2	0.9

Based upon OBERS Series E population projections for the subregion (Calvert, Caroline, Dorchester, Kent, Queen Annes, Somerset, Talbot, Wicomico, and Worcester Counties, Maryland, and Sussex County, Virginia), the estimated population growth for Dorchester County and for Cambridge is shown in Table D-3. Table D-3 also provides population projections based on a simple regression technique. The "regression" projections are provided for Cambridge and all other communities for comparative purposes as the disaggregation and reaggregation of OBERS data to the community level may be somewhat suspect, particularly for the small communities.

TABLE D-3

POPULATION PROJECTIONS FOR
CAMBRIDGE AND DORCHESTER COUNTY
(1980 - 2020)

	<u>1980*</u>	<u>1990</u>	<u>2000</u>	<u>2020</u>
Dorchester County	30,623	31,400	33,100	39,200
Cambridge (Series E)	11,703	13,000	14,000	17,100
Cambridge (Regression)	11,703	13,300	13,900	15,200

*The 1980 populations presented for Cambridge and Dorchester County are the final counts as determined by the Bureau of the Census.

OCCUPATIONAL DISTRIBUTION

The work force in Cambridge is highly concentrated in the category of Operatives with almost 29 percent of the work force aged 16 years or older employed in this category. One would expect a similar distribution for the county and in fact this does occur. County figures show that the category of Operatives constitutes almost 29 percent of the work force aged 16 years or older. However, state figures shown in Table D-4 indicate that the Sales and Clerical occupational grouping employs the largest percentage of the work force with Operatives ranked fourth.

Unemployment in Cambridge in 1970 was approximately 5 percent which compares with a slightly higher County total of 6.2 percent and a State figure of 3.2 percent.

INCOME CHARACTERISTICS

Individual median income in the community of Cambridge in 1970 was \$2,252. Median family income was \$7,394. Nearly 15.9 percent of the families had an income below the poverty level. County figures on 1970 median income are shown in Table D-4. These figures indicate a slightly lower individual median income of \$2,094 with median family income slightly higher at \$7,702. Approximately 14.8 percent of the families were defined as being at or below the poverty level. Both community and County figures regarding income fall well below State figures as shown in Table D-4 while the percentage of families defined as being at or below the poverty level is significantly higher at both the community and the county level.

TABLE D-4

DEMOGRAPHIC AND SOCIO-ECONOMIC CHARACTERISTICS
FOR CAMBRIDGE, DORCHESTER COUNTY AND MARYLAND
(1970)

<u>DEMOGRAPHIC CHARACTERISTICS</u>	<u>CAMBRIDGE</u>	<u>DORCHESTER COUNTY</u>	<u>MARYLAND</u>
Population	11,595	29,405	3,922,400
Median Age	33.1	34.1	27.1
Percent 35 years or older	48.0	49.1	40.0
<u>OCCUPATIONAL DISTRIBUTION*</u>			
Prof. Managerial	17.9	16.1	27.6
Craftsmen, Foremen	12.5	14.8	13.7
Operatives, (incl. transportation)	28.6	28.7	13.3
Labor (incl. farm)	7.9	9.8	4.6
Farm Managers	-	2.3	0.7
Services	16.4	12.9	11.6
Sales and Clerical	16.6	15.1	28.1
Unemployed	5.0	6.2	3.2
<u>INCOME CHARACTERISTICS</u>			
Median Individual Income	\$2,252	\$2,094	\$3,099
Median Family Income	\$7,394	\$7,702	\$11,063
Percent of families below poverty level	15.9	14.8	7.7
<u>EDUCATIONAL CHARACTERISTICS</u>			
Percent of individuals 25 years or older with High School completion	23.8	28.5	52.3
<u>HOUSING CHARACTERISTICS</u>			
Year-round Housing Units	4,414	10,841	1,234,469
Median gross value of rent	\$ 80/month	\$ 79/month	\$ 127/month
Median value of owner-occupied housing	\$11,924	\$10,700	\$18,800
Percent of units moved into in last 5 years	45.2	41.5	52.2

*Based on Percent of Labor Force Aged 16 Years or Older.

EDUCATIONAL CHARACTERISTICS

As seen in Table D-4 approximately only 24 percent of those Cambridge residents age 25 years or older had completed their high school education. This compares with a somewhat higher figure of 28.5 percent for the County and a substantially higher figure of 52.3 percent for the State.

HOUSING CHARACTERISTICS

The number of occupied housing units in Cambridge in 1970 was 4,414 with a median value of gross rent of \$80 per month and a median value of owner-occupied housing of \$11,924. County totals compare showing a median value of gross rent of \$79 per month and a median value of owner-occupied housing of \$10,700. Again, both community and County figures fall well below the State values of \$127 per month for median value of gross rent and \$18,800 for the median value of owner-occupied housing.

INDUSTRIAL EMPLOYMENT

As seen in Table D-5 the overwhelming majority of industrial employment in Cambridge occurs in the Manufacturing sector, followed far behind by the Wholesale and Retail Trade sector. In the case of Cambridge there seems to be a fairly wide range of manufacturing activities represented. While only ten firms contributed 83 percent of the employment in the manufacturing sector, the firms themselves are fairly diverse, engaging in a variety of manufacturing endeavors such as circuit breaker assembly, clothing, printing, and seafood production and processing.

County figures expectedly also reflect a significant dependence upon the Manufacturing sector with almost 39 percent of the work force 16 years of age or older employed in this sector. State figures indicate considerably less concentration in this sector as seen in Table D-5.

TABLE
CAMBRIDGE 1970 INDUSTRIAL EMPLOYMENT
(Work force 16 yrs. of age or older)

<u>SECTOR</u>	<u>CAMBRIDGE (%)</u>	<u>DORCHESTER COUNTY (%)</u>	<u>MARYLAND (%)</u>
Construction	6.6	6.7	6.6
Manufacturing	39.7	38.8	19.5
Public Utilities and Transportation	5.9	5.5	6.8
Wholesale and Retail Trade	17.1	16.2	19.2
F.I.R.E. and Repair Services*	3.1	3.6	8.5
Professional and Related Services	11.7	11.4	12.3
Educational Services	6.0	4.8	8.1
Public Administration	3.1	3.9	13.5
Other	<u>6.9</u>	<u>9.1</u>	<u>5.5</u>
Total	100.0	100.0	100.0

*F.I.R.E. is an acronym for Finance, Insurance, and Real Estate.

TRANSPORTATION

Railroads

The Penn Central Transportation Company provides freight service five days a week to Dorchester County. There are two branch lines which intersect at Hurlock; one serves the eastern part of the County and one terminates at Cambridge. Both lines connect with the main line at Seaford, Delaware. The majority of rail traffic is inbound with commodities such as chemicals, fertilizer, lumber and plywood, farm machinery and raw materials for processed foods.

Highways

The principal artery of the highway system serving Dorchester County is U.S. Route 50 which crosses the County from east to west and then crosses the Chesapeake Bay Bridges to link the County with the Baltimore-Washington area. Principal arterials serving Cambridge are U.S. Route 50, Md. Route 16 and Route 343 (Washington Street), with U.S. Route 50 and Washington Street the most heavily used streets.

Washington Street really does not provide the service expected of a principal arterial as it divides neighborhoods, is congested and functions more as a local street. Race Street provides the main access to Cambridge from the south, though it too divides neighborhoods and is much too narrow to handle large volumes of traffic effectively. High Street in most sections is also too narrow and is burdened by traffic lights. Maryland Avenue generally works well as an arterial. Locust and Glasgow Streets are designated as arterials but are really local, very narrow streets with portions in poor condition. Major proposed changes in the Cambridge vicinity consist primarily of the intention to relocate U.S. Route 50 east of the city and to extend Hambrooks Boulevard to Washington Street (Route 343) and to the Cambridge Beltway (Md. Route 16).

Truck Service

The American Motor Carrier Directory lists ten motor freight common carriers of general commodities authorized to serve Dorchester County with truckload and/or less than truckload service. One motor freight carrier has terminal facilities in Cambridge.

Bus Service

Trailways serves Dorchester County with daily bus service that provides connections with any major point. The bus company also handles small freight shipments. Highly specialized mini-bus service is available to the City and County through the Dorchester Community Development Corporation.

Water Transportation

The Port of Cambridge is the only deepwater port on the Delmarva Peninsula. It was constructed in 1963-64 and handles primarily frozen fish products and cheese and cod liver oil products. The port presently shows approximately only 32 percent time utilization of its facilities.

The Cambridge Harbor consists of a channel 150 feet wide and 16 feet deep from that depth in the Choptank River to the Market Street Bridge then 100 feet wide and 16 feet deep to the head of the harbor with a turning basin of the same depth and irregular dimensions comprising approximately 2.4 acres. There are also two anchorage basins and a channel 60 feet wide and 7 feet deep from that depth in the Choptank to the municipal boat basin. The existing State dredged channel consists of a channel 150 feet wide and 25 feet in depth from that depth in the Choptank to the mouth of Cambridge Creek.

Traffic movements in Cambridge Harbor in calendar year 1981 reveal that the most significant commodities being handled are fish, slag, and sand and gravel products as indicated in Table D-6.

The Port of Baltimore, about 74 miles northwest of Cambridge, is the third largest foreign tonnage port in the United States and is second only to New York in container traffic. The Port is open throughout the year and is served by a channel 42 feet deep.

Air Service

The Cambridge Municipal Airport is located three miles southeast of Cambridge. The Airport handles more than 15,000 arrivals and departures yearly, all of them charter or private flights. The airport has facilities suitable for up to two engine commercial jets.

The Salisbury-Wicomico Airport is located 36 miles southeast of Cambridge in Wicomico County. The Easton Municipal Airport, 15 miles north of Cambridge in Talbot County, offers scheduled daily service to Baltimore and Washington by two private airlines. The Baltimore-Washington International Airport (BWI), nine miles south of Baltimore and within two hours driving time from Cambridge, is served by all major air carriers and commuter airlines and offers international jet service.

TABLE D-6

CAMBRIDGE HARBOR 1981 WATERBORNE COMMERCE

<u>HARBOR OR WATERWAY</u>	<u>COMMODITY</u>	<u>TONS</u>
Cambridge Harbor, MD.	0911 Fresh Fish, except shellfish	43,732
	0912 Shellfish, except prepared	912
	1442 Sand, Gravel, Crushed Rock	33,605
	1491 Salt	1
	2211 Basic Textile Products	1
	2691 Pulp and Paper Products, NEC	1
	3312 Slag	20,365
	3511 Machinery, Except Electrical	1
	3711 Motor Vehicles, Parts, Equip.	3
	TOTAL	98,621

SOURCE: Waterborne Commerce Statistics of the United States, Calendar Year 1981, Department of the Army, Corps of Engineers, February 1983.

COMMUNICATIONS

Postal Facilities

Dorchester County is served by 19 post offices. The largest of these, a Class I facility, is located in Cambridge. Hurlock has a Class II post office and East New Market and Secretary have Class III post offices. The other post offices are strategically located throughout the County.

Telephone Services

The Chesapeake and Potomac Telephone Company of Maryland serves the entire County with a modern dial telephone system for direct nationwide dialing.

Radio and Television

WCEM (AM and FM), the local Cambridge radio station, is well established in the area for radio coverage and advertising. Emergency radio communications are available through the local station, State Police facilities, county roads department, volunteer fire companies or through the central fire alarm headquarters in Cambridge, the marine police, and the Wilmington marine operator.

Television and radio reception are available on all national networks from Baltimore, Washington and Salisbury. Cable Antenna Television (CATV) is also available to Cambridge residents and to homes in the County up to three miles beyond the city limits. The Cambridge CATV provides listeners with a 21 station selection, including all Baltimore and Washington channels, educational and FM channels.

Newspapers

Dorchester County is served by two newspapers, both published in Cambridge. The Daily Banner is published every day except Saturday and Sunday and has a circulation of over 10,000 paid copies. The Dorchester News, a weekly, has a circulation of about 3,230 copies and is issued each Thursday. The County is also served by daily papers from Salisbury, Wilmington, Philadelphia, Baltimore and Washington; and by Sunday papers from New York, Philadelphia, Baltimore and Washington.

UTILITIES

Electricity and Gas

The Delmarva Power and Light Company of Maryland supplies electricity to most of the towns and developed areas from a transmission system serving the County. The Choptank Electric Cooperative, Inc., provides central station electricity to the rural areas of Dorchester County.

The Eastern Shore Natural Gas Company serves the Delmarva Peninsula. The Cambridge Gas Company has distribution mains in the City of Cambridge and distributes natural gas purchased from the Eastern Shore Natural Gas Company. The local bottled gas companies provide tank service to homes and other facilities on a County-wide basis. The proximity to Baltimore permits easy access to supplies of coal and oils via barge, truck or rail.

Water and Sewerage

The Towns of Cambridge, East New Market, Hurlock, Secretary, and Vienna have municipal water systems. The City of Cambridge water system is operated by the Municipal Utilities Commission and water is obtained from ten deep wells. The present water supply is from wells from the Piney Point, Magothy, and Raritan aquifers.

The Towns of Cambridge, East New Market, Hurlock, Secretary, and Vienna have municipal sewer systems. The Cambridge Wastewater Treatment Plant was constructed in 1937 as a primary treatment plant. The plant has been expanded and modernized over the years. The most recent renovation was completed late in 1973 and provides an activated sludge process to provide secondary treatment as well as a shellfish protection holding pond. The system has a capacity of 8.1 million gallons per day (mgd) (expandable to 10.3 mgd) and has an average daily flow of 5.5 mgd. Future plans call for additional interceptors and force mains in previously unsewered areas. Current plans do not envision any expansion of current capability.

COUNTY SERVICES

Law enforcement agencies in Dorchester County include the Cambridge police force, the County Sheriff's office, and the Maryland State Police. There are 14 volunteer fire companies in Dorchester County. Each of them is well equipped with from two to four pieces of motorized equipment. Nine of the 14 fire companies provide ambulance service. These are strategically located to provide adequate coverage throughout the County.

The City of Cambridge has regular trash and garbage collection. Most of the incorporated towns have regular trash and garbage collection but there is no County-wide collection service. Collection service may also be arranged through private contractors. There are three large County-operated land-fills available in the County.

EDUCATIONAL SERVICES

The educational program includes grades K-12. There are presently 16 schools in operation which serve the County and the City of Cambridge: seven elementary schools, three secondary schools, five combined institutions, and one vocational-technical school. These schools serve approximately 5,300 students. There are also four nonpublic schools in the County with an enrollment estimated at approximately 330 students. While there is no institution of higher learning in Dorchester County, there are four colleges nearby: Chesapeake College, Salisbury State College in Wicomico County, Washington College in Kent County, and the University of Maryland-Eastern Shore Branch in Somerset County.

HEALTH SERVICES

Dorchester General Hospital in Cambridge was completed in 1974 and contains 123 beds and employs over 250 persons. Located immediately adjacent to the present City limits is the Eastern Shore Hospital Center, a fully accredited mental hospital operated by the State.

The Dorchester County Health Department has administrative offices in Cambridge. The department makes regular inspections throughout the County with eleven clinics in constant operation. There are four privately operated nursing homes in Dorchester County, two of them located in Cambridge with a total of 152 beds, one in Hurlock and one in nearby Williamsburg.

CULTURAL INSTITUTIONS

Libraries and Churches

The Dorchester County Central Library is located in Cambridge. There is also a branch in Hurlock and a bookmobile which serves outlying areas. Churches representing most major denominations are located in the County. The nearest synagogue is located in Easton approximately 15 miles north of Cambridge.

Historic Sites

There are approximately 260 sites in the vicinity of Cambridge identified by the Maryland Historical Trust as being of significance to the history of the town and county and which will be submitted for inclusion in the National Register of Historic Places. Four sites, Glasgow, Brinsfield I Site, Stanley Institute, and Yarmouth are currently listed on the National Register. In terms of reported archeological sites in the vicinity of Cambridge (within a one mile radius), the Maryland Geological Survey has identified five existing sites (two historical, three aboriginal) of low to medium sensitivity (i.e., may be eligible for inclusion in the National Register). The Maryland Geological Survey also notes that there is a high potential for significant archeological resources in Cambridge.

LAND USE

Existing Land Use

Table D-7 below indicates the various types of land use in the City of Cambridge in the year 1976. Most significant are the agricultural and wooded areas followed by residential development. Annexations in 1974 and 1976 have dramatically increased the acreage of the City by almost 1,500 acres or by more than 75 percent of the pre-1974 level.

TABLE D-7

LAND USE IN CAMBRIDGE, MARYLAND

<u>CATEGORY</u>	<u>ACRES</u>	<u>PERCENT OF AREA WITHIN CITY LIMITS</u>
Residential	952.7	27.7
Commercial	219.0	6.4
Industrial	180.7	5.2
Agricultural, Wooded	1,711.5	49.7
Public, Semi-public	247.7	7.2
Parks/Open Spaces	132.4	3.8
TOTAL	3,444.0	100.0

There are definite sections of differing housing quality within the City limits. Many structures of low value are located in an area bounded by Maces Lane, Bayly Road, Race Street, Park Lane and Leonards Lane. This area exhibits the greatest concentration of economic need in the City.

Housing seems to be very sound in the area north of Park Lane bounded by Cambridge Creek on the east, the City limits on the west and the Choptank River on the north. Almost all of the distinctive and historic structures surveyed by the City are contained in this area. Housing is usually sound in the area bounded on the east by the City limits, on the north by the Choptank River, on the south by U.S. Route 50 and Washington Street, and on the west by Railroad Avenue and Hayward Street with a few pockets of housing indicating some deterioration.

The area bounded by Race Street on the west, Trenton Street on the east, the Choptank River on the north and Cedar Street on the south is the downtown commercial core, with the concentration on Cedar, Academy, and Washington Streets. Structural conditions of most of these establishments range from high to low quality. Considerable commercial development also exists along Route 50. This development is situated to take advantage of the trade commuting to Ocean City. Most commercial structures in this area are in good to excellent condition.

Most of the industrial land in Cambridge is located in the area immediately adjacent to Cambridge Creek with another section bounded by the railroad tracks, Woods Road (the City limits), and U.S. Route 50. These consist of an admixture of old and new industrial structures. (Some of the land adjacent to Cambridge Creek has recently been redeveloped in conjunction with construction of waterfront residential townhouses by the American Cities Corporation.)

Most public and semi-public land use is scattered throughout the community though there is a grouping of government offices in the area of Poplar, Spring, and Cove Streets near Cambridge Creek. Most of these structures are in good condition.

Future Land Use

The Comprehensive Plan for the City of Cambridge recommends that the area north of Park Lane bounded by Cambridge Creek to the east, the City limits on the west and the Choptank River on the north be established as a historic zoning district. The plan also recommends that the residential area bounded by Washington Street on the north, Route 16 on the south, Boundary Road on the east and Bayly Road on the west be maintained as a solidly residential area. In the residential area bounded on the west by Railroad Avenue and Hayward Street, on the east by the City limits, on the north by the Choptank River and on the south by U.S. Route 50 and Washington Street, some effort is expected to be expended to upgrade some of the existing units but the basic character of the area will remain unchanged.

The Comprehensive Plan suggests that development of the area along Cambridge Creek must consider that a large portion of this area lies within the 100-year flood plain. The Plan suggests encouragement of commercial activity and revitalization of the area to include eliminating industrially zoned land surrounding the creek. (In December 1980,

the American Cities Corporation released a plan for developing this area around Cambridge Creek into a waterfront community and tourist area. Several townhouses have been constructed and plans include construction of a luxury hotel and marina on the Creek.)

The "old industrial" area defined by Boundary Road on the west, Washington Street on the north, Route 16 on the south and the City limits on the east, will presumably be demolished and/or renovated for the purpose of attracting "quality" in-town industrial sites. It is also proposed that land on the east and west side of Woods Road to or beyond Route 16 will be used as an industrial growth area.

The Comprehensive Plan for Dorchester County divides the County into two major land use categories: 1) growth areas, or areas where the county would like to encourage new development, and 2) conservation areas, or areas which the county would like to maintain for agricultural or open space purposes. The plan designates the county's nine municipalities and 17 of its unincorporated villages as growth areas and proposes that new development be clustered in and around these existing population centers. These 26 growth areas are further broken down into four groups; 1) the Cambridge area, or the County's principal growth area, 2) the Hurlock area, the County's second growth area, 3) the East New Market, Secretary and Vienna areas which are capable of limited development, and 4) the small towns and villages suitable only for minor additional residential development which include the County's remaining incorporated towns (such as Brookview, Church Creek, Eldorado, and Galestown and 17 unincorporated villages).

The conservation areas are defined as the wetlands, farmlands, forests and waterfront areas. Wetlands are defined as the marshy areas located in southern Dorchester County along the Choptank, Nanticoke, Marshyhope and Blackwater Rivers. Waterfront areas that exist mainly along the Choptank and Little Choptank Rivers are very desirable for residential development. Land use objectives require that the open and natural character of the waterfront areas be maintained by restricting development to agricultural, residential and related uses.

CRISFIELD, MARYLAND

DEMOGRAPHIC CHARACTERISTICS

Crisfield, Maryland, is a fair sized community with a 1970 population of 3,075 located on the southwestern tip of Somerset County. The population of Crisfield is somewhat aged with approximately 53 percent of the population 35 years of age or older and a median age of 37.7 years versus county figures of 47.3 percent and 32.1 years old, respectively. The figures for the state indicate that 40 percent of the population is age 35 years or greater with 27.1 years representing the median age. Historical population trends for Crisfield, Somerset County, the State of Maryland, and the United States are shown in Table D-8 below.

TABLE D-8

HISTORICAL POPULATION FOR THE U.S., MARYLAND,
SOMERSET COUNTY, AND CRISFIELD
(1940-1980)

	<u>1940</u>	<u>1950</u>	<u>1960</u>	<u>1970</u>	<u>1980</u>
UNITED STATES	132,165,000	151,326,000	179,323,000	203,212,000	226,504,825
% change	-	14.5	18.5	13.3	11.5
MARYLAND	1,821,000	2,343,000	3,100,000	3,922,400	4,216,941
% change	-	28.6	32.3	26.5	7.5
SOMERSET COUNTY	20,965	20,745	19,623	18,924	19,188
% change	-	-1.0	-5.4	-3.6	1.4
CRISFIELD	3,908	3,668	3,540	3,075	2,924
% change	-	-6.1	-3.5	-13.1	-4.9

As can be seen in the above table, population has been declining for several decades in both Somerset County and in Crisfield. However, the 1980 population data indicate that the County experienced a slight increase in population.

Based on OBERS Series E population projections for the subregion for the period 1980-2020, the estimated population growth for Crisfield and Somerset County is shown in Table D-9. It should be noted that the regression technique yielded projections that are lower and probably more realistic considering recent historical trends.

TABLE D-9

POPULATION PROJECTIONS FOR CRISFIELD AND SOMERSET COUNTY
(1980-2020)

	<u>1980*</u>	<u>1990</u>	<u>2000</u>	<u>2020</u>
Somerset County	19,100	20,400	21,100	24,000
Crisfield (Series E)	3,100	3,200	3,200	3,500
Crisfield (Regression)	2,900	2,600	2,400	1,800

*The 1980 populations presented for Crisfield and Somerset County are the final counts as determined by the Bureau of the Census.

OCCUPATIONAL DISTRIBUTION

Somerset County has a relatively low-skilled labor force as shown in Table D-10. The table shows a high proportion of Operatives (25.7 percent) in comparison to state percentages. These skills are normally associated with low-wage labor intensive industries. The county lacks professional and technical workers which constitute only 15.3 percent of the work force 16 years or older.

Crisfield also reflects this tendency toward a relatively low-skilled labor force with approximately 22.6 percent of the work force aged 16 years or older employed as Operatives. Only 15.6 percent of Crisfield's work force is classified as Professional or Managerial. These figures compare rather poorly with state totals of 13.3 percent of the work force employed as Operatives and 27.6 percent in the Managerial, Professional category.

INCOME CHARACTERISTICS

Individual median income in Somerset County rates close to the bottom of the list of all Maryland counties at \$1,173 in 1970. Median family income shares this somewhat dubious distinction at \$5,890 while 24.5 percent of the families in the county are defined as at or below the poverty level. Figures for Crisfield are also very low when compared to the state figures, with \$1,568 as the median income for individuals and \$5,270 as the median income for families with 24.4 percent of the families below the poverty level in 1970.

EDUCATIONAL CHARACTERISTICS

One weakness of Somerset County and Crisfield appears to be the low level of educational attainment of the population. Only 21.5 percent of the Somerset County residents 25 years of age or older had completed high school. Crisfield fared even worse with only 14 percent of the 1970 population 25 years of age or older having completed high school. These figures compare very poorly with the state figure of approximately 52 percent.

HOUSING CHARACTERISTICS

The number of year-round housing units in Somerset County in 1970 was 6,897 with a gross rent median value of \$65/month and a median value of owner-occupied housing of \$7,900. Figures for Crisfield indicate 1,222 occupied units in 1970 with a median gross rent of \$65/month and a median value of owner-occupied housing of \$8,170. All figures fall well below the state figures for median value of rent (\$127/month) and median value of owner-occupied housing (\$18,800) as shown in Table D-10.

INDUSTRIAL EMPLOYMENT

As seen in Table D-11, the majority of those 16 years of age or older in Somerset County are employed in Manufacturing (26.9 percent) closely followed by the Wholesale & Retail Trade category. The Manufacturing industry in Crisfield seems fairly diverse, with several large companies engaging almost 60 percent of those employed in this sector: Rubberset (220), Geo. A. Cristy Seafoods (150) and Carvel Hall Cutlery (150). Most

TABLE D-10

DEMOGRAPHIC AND SOCIO-ECONOMIC CHARACTERISTICS
FOR CRISFIELD, SOMERSET COUNTY AND MARYLAND
(1970)

<u>DEMOGRAPHIC CHARACTERISTICS</u>	<u>CRISFIELD</u>	<u>SOMERSET COUNTY</u>	<u>MARYLAND</u>
Population	3,075	18,924	3,922,400
Median Age	37.7	32.1	27.1
Percent 35 years or older	52.9	47.3	40.0
<u>OCCUPATIONAL DISTRIBUTION*</u>			
Prof. Managerial	15.6	15.3	27.6
Craftsmen, Foremen	10.0	13.0	13.7
Operatives (incl. transportation)	22.6	25.7	13.3
Labor (incl. farm)	10.3	11.2	4.6
Farm Managers	-	4.0	0.7
Services	14.4	12.5	11.6
Sales & Clerical	27.0	17.9	28.1
Unemployed	16.0	12.7	3.2
<u>INCOME CHARACTERISTICS</u>			
Median Individual Income	\$ 1,568	\$ 1,173	\$3,099
Median Family Income	\$ 5,270	\$ 5,890	\$11,063
Percent of families below poverty level	24.4	24.5	7.7
<u>EDUCATIONAL CHARACTERISTICS</u>			
Percent of individuals 25 years or older with high school completion	14.0	21.5	52.3
<u>HOUSING CHARACTERISTICS</u>			
Year-round Housing Units	1,222	6,897	1,234,469
Median gross value of rent	\$ 65/month	\$ 65/month	\$ 127/month
Median value of owner-occupied housing	\$8,170	\$7,900	\$18,800
Percent of units moved into in last 5 years	50.2	34.5	52.2

*Based on Percent of Labor Force Aged 16 Years or Older.

TABLE D-11

CRISFIELD 1970 INDUSTRIAL EMPLOYMENT
(Work force 16 years or older)

<u>SECTOR</u>	<u>CRISFIELD (%)</u>	<u>SOMERSET COUNTY (%)</u>	<u>MARYLAND (%)</u>
Construction	7.7	7.3	6.6
Manufacturing	23.2	26.9	19.5
Public Utilities & Transportation	5.1	4.3	6.8
Wholesale & Retail Trade	29.5	21.0	19.2
F.I.R.E. & Repair Services*	4.4	4.3	8.5
Professional & Related Services	7.0	8.4	12.3
Educational Services	9.1	7.8	8.1
Public Administration	5.9	4.8	13.5
Other	8.1	15.2	5.5
Total	100.0	100.0	100.0

*F.I.R.E. is an acronym for Finance, Insurance, and Real Estate.

smaller manufacturing establishments are water-oriented which is to be expected considering the ease of access to Bay waters. State figures also show the Manufacturing and Wholesale and Retail Trade sectors as the major areas of employment. Industrial distribution of employment in Crisfield indicates that 29.5 percent of the work force 16 years of age or greater are employed in Wholesale & Retail Trade while Manufacturing constitutes 23.2 percent.

TRANSPORTATION

Railroads

Somerset County's location on the southernmost tip of Maryland's eastern shore has served as an inhibiting factor in the growth of the county's economy. Many of the problems within the county arise from its inaccessibility to major metropolitan areas. Though the Conrail railroad network continues to provide rail service to Princess Anne, King's Creek and to Pocomoke City, as of April 1976 several lines were abandoned as a result of the reorganization of the bankrupt Penn Central Railroad which included the King's Creek-Crisfield Line. Like many other counties on the lower eastern shore of Maryland, Somerset County also possesses no rail passenger service.

Highways

The principal artery of the highway system serving Somerset County is U.S. Route 13, which extends north to Wilmington and the New Jersey Turnpike and extends south through the Virginia portion of the eastern shore and connects with the Chesapeake Bay Bridge-Tunnel to Norfolk. Maryland Route 413 links Crisfield with other areas of the County and is the major highway spine of the community. Other streets such as Somerset Avenue, Jacksonville Road, Main Street/Md. 380, and Fourth Street/Woodson School Road carry a rather high volume of traffic.

Truck Service

The American Motor Carrier Directory lists 12 motor freight common carriers of general commodities authorized to serve Somerset County with truckload and/or less-than-truckload service. Three of the freight carriers maintain terminal facilities in nearby Salisbury in Wicomico County.

Bus Service

Trailways and Greyhound provide Somerset County with daily bus service that includes one stop in Princess Anne and one in Westover. Small freight shipments are also handled by the bus companies. At present, there is no public transportation in Crisfield.

Water Transportation

As noted earlier, the Port of Cambridge is the only deepwater port on the Delmarva Peninsula. The marine terminal, built on the Choptank River waterfront in Cambridge, is 15 miles upstream from the main shipping lane in the Chesapeake Bay and 100 nautical miles from the Virginia Capes. The Port of Baltimore, about 120 miles northwest of Princess Anne, is the third largest foreign tonnage port in the United States and is second only to New York in container traffic. The port is open throughout the year and is served by a channel 42 feet deep.

The harbor in Crisfield, though authorized for a depth of 14 feet, presently has only an eight foot channel due to siltation. The economy of the county could be dramatically improved with the development of a deepwater port at Crisfield. This proposal has been under consideration by local interests. Traffic in Crisfield Harbor is primarily associated with the shellfish industry, as indicated in Table D-12 below. Figures cited are for calendar year 1981 and were taken from the publication Waterborne Commerce of the United States.

Air Service

The Salisbury-Wicomico Airport is located about 17 miles northeast of Princess Anne in Wicomico County. There are U.S. Air commuter flights daily to Baltimore-Washington International Airport, Washington National Airport, and Philadelphia International Airport. The Airport, situated on over 800 acres, has two 5,000-foot paved runways and one 5,500-foot paved runway. Services and facilities available include full instrument landing system (ILS), VOR navigational equipment, fuel, charter service, air freight service, student instruction, auto rentals, and hangar space for private and corporate aircraft. The FAA also operates a flight service station at the airport.

Crisfield Airport, a municipally operated facility three miles north of Crisfield, has two lighted runways - one 3,500-foot turf runway and one 2,500-foot paved runway. Services and facilities available include: fuel, major maintenance, tie downs, attended during daytime, and taxi service.

TABLE D-12

CRISFIELD HARBOR 1981 WATERBORNE COMMERCE

<u>HARBOR OR WATERWAY</u>	<u>COMMODITY</u>	<u>TONS</u>
Crisfield Harbor, MD	0911 Fresh Fish, Except Shellfish	83
	0912 Shellfish, Except Prepared	35,041
	0931 Marine Shells, Unmanufactured	3,582
	1121 Coal and Lignite	11
	2094 Groceries	102
	2095 Ice	33
	3411 Fabricated Metal Products	7
	4112 Commodities, NEC	113
	TOTAL	38,972

SOURCE: Waterborne Commerce Statistics of the United States, Calendar Year 1981, Department of the Army, Corps of Engineers, February 1983.

COMMUNICATIONS

Postal Facilities

There are 18 post offices located in Somerset County. Princess Anne and Crisfield have first class offices. In addition, there are six third class and ten fourth class facilities in smaller communities throughout the County. The mail boat from Crisfield provides daily service to Smith Island.

Telephone Services

The Chesapeake and Potomac Telephone Company of Maryland serves the entire County with a modern dial telephone system for direct nationwide dialing. The Chesapeake and Potomac Telephone Company has the facilities to expand their services to meet any increased demand. Other telecommunications suppliers are Western Union, IT&T, and Comsat.

Radio and Television

Radio and Television reception is excellent from stations located on the Eastern Shore. WBOC-TV, Salisbury, serves the area with network programming. CATV service is available in Princess Anne and Crisfield. There are no radio or television stations within Somerset County.

Newspapers

Somerset County is served by two weekly newspapers. The Marylander and Herald, published in Princess Anne, has a paid circulation of about 1,830. The Crisfield Times, published in Crisfield, has a paid circulation of over 2,600. In addition, Salisbury and Baltimore newspapers enjoy a large circulation in the County.

UTILITIES

Electricity and Gas

The Delmarva Power and Light Company of Maryland supplies electricity to most of the towns and developed areas. The substation facilities in Somerset County are adequate for the electric load in the area and could be expanded to accommodate any load which might develop in this vicinity.

The Choptank Electric Cooperative, Inc., provides central station electricity to the rural areas of Somerset County. Choptank Electric Cooperative can and will expand their services and equipment to meet any demand for electric service for all uses, subject to the established terms and conditions of the cooperative. Propane gas and fuel oil are available in Somerset County from local dealers and distributors.

Water and Sewerage

The water resources in the County can generally be described as good. The quality and quantity of water available is adequate for most uses, and usually does not require drilling to, or pumping from, excessive depths. A demand in excess of 750 gpm can be met by tapping the Pleistocene-Pliocene aquifer lying at an approximate depth of 20 to 80 feet.

There are municipal water systems in Crisfield and Princess Anne. The Crisfield water system consists of five wells which have a capacity of 2.0 mgd. The water receives no treatment. The distribution system extends to the Carvel Hall plant, one mile northeast of the corporate limits. The residences outside the city limits are served by a series of small private lines. A new principal loop was installed in 1973 within the city. The Harbor Industrial Area mains have been rehabilitated. The current usage is 1.2 mgd. Storage consists of a 250,000 gallon standpipe.

There are municipal sewer systems in Crisfield and Princess Anne. A system is being planned for Smith Island. The sewerage system serves the entire town of Crisfield and that area adjacent to Route 413 to the Carvel Hall Plant, one mile northeast of the corporate limits. The treatment plant is a secondary extended aeration type with a capacity of 1.00 mgd. The average daily flow is 0.6 mgd. The treated effluent is discharged into the Little Annemessex River.

COUNTY SERVICES

The Sheriff's office has three uniformed deputies and three patrol cars. Princess Anne and Crisfield maintain local police departments. All three departments are interconnected with the State Police Headquarters in Salisbury by a modern radio system.

Fire protection is provided in the northern portion of the county by the Princess Anne Volunteer Fire Company and in the southern portion of the county by the Crisfield Volunteer Fire Department. Both companies are jointly funded by county and town appropriations. Volunteer fire departments are also active in Deal Island, Ewell, and Marion Station. The volunteer fire companies in Princess Anne and Crisfield provide ambulance service. Both Princess Anne and Crisfield operate municipal refuse collection facilities.

EDUCATIONAL SERVICES

The educational program in the county includes grades kindergarten through 12. There are approximately 15 schools located in the county with an enrollment of approximately 3,600 students. Educational facilities in the Crisfield area consist of two elementary, one middle and one high school. There are two nonpublic schools in the county with an enrollment of approximately 50 students.

The University of Maryland-Eastern Shore Branch, a fully accredited four year public college, is located in Princess Anne. Salisbury State College, another fully accredited four year college, is located in Salisbury. Tawes Vocational School provides vocational and technical training in programs ranging from automechanics to marine harvest to health occupations.

HEALTH SERVICES

The McCready Memorial Hospital, in Crisfield, is a general hospital with a 40 bed and 8 bassinet capacity. Residents in the northern part of the county use the facilities of Peninsula General Hospital in Salisbury, 13 miles north of Princess Anne. The Hospital has 370 beds and a staff of over 90 physicians and surgeons. It is the largest, fully accredited hospital on the Delmarva Peninsula.

The Somerset County Health Department in Princess Anne administers an active program with four divisions - Administration, Public Health Nursing, Mental Health, and Environmental Health. The Alice B. Tawes Nursing Home, in Crisfield, has a capacity of 64 beds.

CULTURAL INSTITUTIONS

Libraries and Churches

The Somerset County Library system operates branches in Princess Anne, Crisfield, and Smith Island. Churches representing most major denominations are located in the County. Within the City limits of Crisfield there are approximately 12 churches of various denominations.

Historic Sites

There are four sites in the Crisfield vicinity identified by the Maryland Historical Trust which are considered to be of significance to the history of the town and county and which will be submitted for inclusion in the National Register of Historic Places. One of these, Make Peace, is currently listed on the National Register. In terms of reported archeological sites in the vicinity of Crisfield (within a radius of approximately one mile), the Maryland Geological Survey has indicated that there are currently no sites recorded in the area, although a high potential for sites does exist.

LAND USE

The predominant land use category in Crisfield is residential. In the northern portion of the city, along Somerset Avenue and Hall Highway, the land use pattern is relatively large lot single family residential with mixed public and quasi-public uses. Areas in the central portion of the city, generally south and west of Somerset Avenue and Hall

Highway are characterized by a pattern of single family residential use on lots which average 8,000 to 12,000 square feet in area. In areas immediately surrounding the "uptown" central business area, as well as to the south along Fourth Street and Charlotte Street, there are apartments, semi-detached and attached housing intermixed with single family detached. In addition, there is a large area which is undeveloped south of Cove Street between Somerset Avenue and Charlotte Street.

Information on county land use policies is scarce with comments limited only to the fact that Princess Anne, Westover, and Crisfield are the major areas in the county for residential, commercial and industrial development. County planners have not quantified existing land usage nor made land use projections. Comments are limited to the mention that further commercial and industrial development will be encouraged to take place in the localities mentioned above.

Other than in the central business area, the only planned commercial use occurs on Route 413 in the vicinity of the Potomac Street intersection and along Jacksonville Road. The central business district includes the "downtown" and the "uptown" commercial areas running along Main Street from the city dock to Third Street. This seven block strip contains heavy concentrations of commercial activity, vacant lots, multi-family use and a few scattered industrial uses close to the water.

Industrial activity in Crisfield is centered along the waterfront north of Main Street and on the tip of Jersey Island. At least one-half of the industrial activity is related to the use of the water.

POCOMOKE CITY, MARYLAND

DEMOGRAPHIC CHARACTERISTICS

Pocomoke City is located in southwestern Worcester County and had a 1970 population of 3,573. The population's median age was 34.5 years and approximately 50 percent of the population was 35 years of age or older. This compares with a 1970 Worcester County median age of 31.5 years with 46.4 percent of the County population aged 35 years or older. State figures indicate a median age of 27.1 years with approximately 40 percent of the population aged 35 years or older. Historical population trends for Pocomoke City, Worcester County, the State of Maryland and the United States are shown in Table D-13.

As indicated in Table D-13 in the 1940 - 1970 period Pocomoke City grew somewhat more rapidly than the County yet significantly less rapidly than either the State or Nation. However, 1980 Census results indicate that while the County grew more than 25 percent in the 1970 - 1980 period, Pocomoke City actually lost population.

Based upon OBERS Series E population projections for the subregion, the estimated populations for Worcester County and for Pocomoke City are shown in Table D-14. It should be noted that linear regression techniques applied to historical data of population growth in Pocomoke City over the period 1940-1970 yield increasingly significant differences from Series E OBERS projections.

TABLE D-13

HISTORICAL POPULATION FOR THE U.S., MARYLAND,
WORCESTER COUNTY, AND POCOMOKE CITY
(1940 - 1980)

	<u>1940</u>	<u>1950</u>	<u>1960</u>	<u>1970</u>	<u>1980</u>
UNITED STATES	132,165,000	151,326,000	179,323,000	203,212,000	226,504,825
% change	-	14.5	18.5	13.3	11.5
MARYLAND	1,821,000	2,343,000	3,100,000	3,922,400	4,216,941
% change	-	28.6	32.3	26.5	7.5
WORCESTER COUNTY	21,245	23,148	23,733	24,442	30,889
% change	-	9.0	2.5	3.0	26.4
POCOMOKE CITY	2,739	3,191	3,329	3,573	3,558
% change	-	16.5	4.3	7.3	-0.4

TABLE D-14

POPULATION PROJECTIONS FOR POCOMOKE CITY AND WORCESTER COUNTY
(1980-2020)

	<u>1980*</u>	<u>1990</u>	<u>2000</u>	<u>2020</u>
Worcester County	30,889	30,700	33,400	41,400
Pocomoke City (Series E)	3,558	4,700	5,200	6,700
Pocomoke City (Regression)	3,558	4,100	4,400	4,900

*The 1980 populations presented for Crisfield and Somerset County are the final counts as determined by the Bureau of the Census.

OCCUPATIONAL DISTRIBUTION

As shown in Table D-15 more than 25 percent of the work force aged 16 years or above in Pocomoke City is employed in the Sales and Clerical category followed by 19.7 percent in the Professional & Managerial and 19.6 percent in the Operatives classification. County figures show that the Professional & Managerial category is the primary occupation followed closely by Operatives, though state figures, for the most part, parallel those of Pocomoke City.

INCOME CHARACTERISTICS

Individual median income in the community of Pocomoke City in 1970 was \$1,538 with median family income of \$7,628 and with 14.4 percent of the families defined to be below poverty level. This compares with County figures of \$1,697 and \$7,368 for the median income of individuals and families, respectively, and with 17.2 percent of the families defined as below the poverty level. State income levels are significantly higher as shown in Table D-15 while the percentage of families existing below the poverty level is substantially lower.

EDUCATIONAL CHARACTERISTICS

Figures in Table D-15 indicate that in Pocomoke City in 1970 approximately 24 percent of those aged 25 years or greater had completed their high school education. This compares unfavorably with both County and State figures of 32 percent and 52 percent, respectively.

HOUSING CHARACTERISTICS

The number of year-round housing units in Pocomoke City was 1,333 in 1970 with a median value of gross rent of \$78 per month and a median value of owner-occupied housing of \$12,403 as shown in Table D-15. County figures display a marked similarity with a median value of gross monthly rent of \$79 and a median value of owner-occupied housing of \$11,400. Both community and county figures appear well below those of the State.

INDUSTRIAL EMPLOYMENT

As shown in Table D-16 approximately 27 percent of industrial employment in Pocomoke City is in the area of Wholesale and Retail Trade followed by Manufacturing with 22.1 percent. The town has a number of fairly large employers in this latter category, with Campbell Soup (300), Somerset Packing (126), Chesapeake Bay Plywood (310), Delmarva Forest (45), and Pocomoke Garment (43) being the most significant. This aggregate distribution is very consistent with both County and State trends as seen in Table D-16.

TRANSPORTATION

Railroads

The Snow Hill Shipper's Association provides freight service to Worcester County and to Pocomoke City as well. There are 14 rail users with 2 or 3 trains per week serving the County. There is no rail passenger service in the County.

Highways

The highway system in Worcester County includes U.S. Route 13, which extends northward to Wilmington and the New Jersey Turnpike and southward through the Virginia portion of the eastern shore and connects with the Chesapeake Bay Bridge-Tunnel to Norfolk. U.S. Route 113 crosses the County and joins U.S. Route 13 at Pocomoke City. Long-range plans of the State Highway Administration are that U.S. Route 113 be dualized for its entire length through the county as a limited access expressway. U.S. Route 50 which has its eastern terminus at Ocean City links the Eastern Shore with the Baltimore-Washington area and points west via the Chesapeake Bay Bridges.

TABLE D-15

DEMOGRAPHIC AND SOCIO-ECONOMIC CHARACTERISTICS
FOR POCOMOKE CITY, WORCESTER COUNTY, AND MARYLAND
(1970)

<u>DEMOGRAPHIC CHARACTERISTICS</u>	<u>POCOMOKE CITY</u>	<u>WORCESTER COUNTY</u>	<u>MARYLAND</u>
Population	3,573	24,442	3,922,400
Median Age	34.5	31.5	27.1
Percent 35 years or older	49.6	46.4	40.0
<u>OCCUPATIONAL DISTRIBUTION*</u>			
Prof. Managerial	19.7	17.9	27.6
Craftsmen, Foremen	14.3	15.1	13.7
Operatives (incl. transportation)	19.6	17.5	13.3
Labor (incl. farm)	5.9	13.3	4.6
Farm Managers	0.7	4.1	0.7
Services	14.4	15.1	11.6
Sales & Clerical	25.5	16.7	28.1
Unemployed	4.7	3.2	3.2
<u>INCOME CHARACTERISTICS</u>			
Median Individual Income	\$1,538	\$1,697	\$3,099
Median Family Income	\$7,628	\$7,368	\$11,063
Percent of families below poverty level	14.4	17.2	7.7
<u>EDUCATIONAL CHARACTERISTICS</u>			
Percent of individuals 25 years or older with High School completion	23.7	32.3	52.3
<u>HOUSING CHARACTERISTICS</u>			
Year-round housing units	1,333	8,962	1,234,469
Median gross value of rent	\$78/month	\$79/month	\$127/month
Median value of owner-occupied housing	\$12,403	\$11,400	\$18,800
Percent of units moved into in last 5 years	38.8	38.1	52.2

*Based on Percent of Labor Force Aged 16 Years or Older.

TABLE D-16

POCOMOKE CITY 1970 INDUSTRIAL EMPLOYMENT
(Work Force 16 yrs. or older)

<u>SECTOR</u>	<u>POCOMOKE CITY (%)</u>	<u>WORCESTER COUNTY (%)</u>	<u>MARYLAND (%)</u>
Construction	7.1	9.9	6.6
Manufacturing	22.1	22.3	19.5
Public Utilities & Transportation	4.8	4.4	6.8
Wholesale & Retail Trade	26.8	18.1	19.2
F.I.R.E. & Repair Services*	4.1	6.5	8.5
Professional & Related Services	3.5	8.3	12.3
Educational Services	7.9	4.3	8.1
Public Administration	9.4	5.2	13.5
Other	<u>14.2</u>	<u>21.0</u>	<u>5.5</u>
Total	100.0	100.0	100.0

*F.I.R.E. is an acronym for Finance, Insurance, and Real Estate.

Truck Service

The American Motor Carrier Directory lists 10 motor freight common carriers of general commodities authorized to serve Worcester County with truckload and/or less-than-truckload service.

Bus Service

Trailways provides Worcester County with daily bus service through which connections with any major point are available.

Water Transportation

The Port of Cambridge is the nearest deepwater port to Worcester County and is located about 50 miles northwest of Snow Hill. The marine terminal, built on the Choptank River waterfront in Cambridge, is 15 miles upstream from the main shipping lane in the Chesapeake Bay and 100 nautical miles from the Virginia Capes.

The Port of Baltimore, about 125 miles from Snow Hill, is the third largest foreign tonnage port in the United States, handling a record 36.9 million tons of export/import trade in 1975. Baltimore, the second largest container tonnage port on the East and Gulf Coasts, moved a total of about 3.4 million tons of containerized general cargo in 1975.

The Pocomoke River is commercially navigable and is used primarily for the barging of petroleum products and wood chips as shown in Table D-17. There is an 11 foot channel 100 to 150 feet in width through Pocomoke Sound from the mouth of the river to deep water in Chesapeake Bay. Private pleasure craft use the river to some extent, particularly during the fishing season.

TABLE D-17

POCOMOKE RIVER 1981 WATERBORNE COMMERCE

<u>HARBOR OR WATERWAY</u>	<u>COMMODITY</u>	<u>TONS</u>
Pocomoke River, MD	2416 Wood Chips, Staves, Moldings	123,637
	2911 Gasoline	10,772
	2914 Distillate Fuel Oil	8,248
	TOTAL	142,657

SOURCE: Waterborne Commerce Statistics of the United States, Calendar Year 1981, Department of the Army, Corps of Engineers, February 1983.

Air Service

The Ocean City Municipal Airport is located 30 miles northeast of Pocomoke City and has a 3,400-foot paved runway which is lighted from dusk to dawn. There is scheduled commuter service to Baltimore-Washington International Airport (BWI) near Baltimore and to Dulles International Airport west of Washington, D.C.

The Salisbury-Wicomico County Airport is located about 20 miles north of Pocomoke City. The U.S. Air commuter has an average of about 28 flights daily to Baltimore-Washington International Airport (BWI), Washington National Airport, and Philadelphia International Airport.

COMMUNICATIONS

Postal Facilities

Worcester County is served by 10 post offices. There are four Class I offices located in Berlin, Ocean City, Pocomoke City, and Snow Hill. There are six Class III offices located in Bishopville, Girdletree, Newark, Showell, Stockton, and Whaleysville. City delivery is provided for the residents in the four Class I office locations. Rural routes also originate from seven of the county post offices for mail delivery to the rural residents.

Telephone Services

The Chesapeake and Potomac Telephone Company of Maryland provides telephone service in Worcester County. Direct distance dialing is available to all customers. The county seat, Snow Hill, is included in the local calling area for every exchange in Worcester County. Western Union, IT&T, and Comsat also provide telecommunications service.

Radio and Television

There are three radio stations in Worcester County. WBOC (AM & FM) has a studio in Ocean City as well as in Salisbury in Wicomico County. WDMV (AM) is located in Pocomoke City and WETT (AM) is located in Ocean City. The nearest commercial television station is WBOC-TV in Salisbury which has a network hookup with ABC, CBS, and NBC. In addition, there is a cable TV system available in all the incorporated towns in Worcester County.

Newspapers

There are three weekly newspapers published in Worcester County—The Eastern Shore Times in Ocean City with a circulation of about 4,000; the Maryland Coast Press in Ocean City with a circulation of about 4,650, and the Worcester County Messenger in Pocomoke City with a circulation of about 3,700. In addition to these newspapers, daily and Sunday papers from Baltimore, Philadelphia, Salisbury, Washington, D.C. and Wilmington have a wide circulation.

UTILITIES

Electricity and Gas

Delmarva Power and Light Company supplies electricity to most of the towns and developed areas in Worcester County. Choptank Electric Cooperative, Inc. provides electrical service to a large portion of rural Worcester County. The Cooperative distributes bulk power to this area from four substations. The distribution system of Choptank Electric Cooperative is interconnected with Delmarva Power and Light Company. Independent municipal propane gas service is available in Berlin, Ocean City, Pocomoke City, and Snow Hill.

Water and Sewerage

There are municipal water systems in Berlin, Newark, Ocean City, Pocomoke City, and Snow Hill. The Pocomoke City water system consists of two wells which are capable of furnishing 1,400 gallons of water per minute. The water supply is filtered and chemically treated. There is an overhead storage tank which has a capacity of 300,000 gallons. Water for industrial purposes is available from the Pocomoke River. The Pocomoke City municipal sewerage system is a modern lagoon system and is considered adequate for future needs. The system discharges into the Pocomoke River.

COUNTY SERVICES

Law enforcement agencies in Worcester County include town police forces in Berlin, Pocomoke City, Snow Hill, and Ocean City. The Pocomoke City Police Department has a chief and nine officers. Fire protection is provided by several volunteer fire companies located in the incorporated towns. Pocomoke City's volunteer company has ample fire fighting equipment and also provides ambulance service on a 24-hour basis. Pocomoke City also provides its residents with regular refuse collection.

EDUCATIONAL SERVICES

There are 13 schools in the County with a total enrollment of approximately 5,000 students. Four of these schools are located in Pocomoke City. The Worcester County Comprehensive Plan envisions the construction of two additional elementary schools in the southern portion of the county and three additional elementary schools in the northern section with an expansion of the existing middle and high schools. There are three nonpublic schools in Worcester County with an enrollment of approximately 360 students.

There is no institution of higher learning located in Worcester County. There are two colleges nearby - Salisbury State College in Wicomico County and the University of Maryland, Eastern Shore Campus in Somerset County. A new regional community college for the lower eastern shore of Maryland has been authorized by the State and will be sponsored by the Worcester and Wicomico County governments. There is also a County Vocational center which offers training in eight trades and occupations.

HEALTH SERVICES

There is no hospital in Worcester County. The majority of the county's citizens use the Peninsula General Hospital in Salisbury, which is the largest, fully accredited hospital on the Delmarva Peninsula. Public health services are provided through the Worcester County Health Department with offices and clinics maintained in Snow Hill, Pocomoke City, and Berlin. There are also two nursing homes in Worcester County with a total bed capacity of 48.

CULTURAL INSTITUTIONS

Libraries and Churches

The Worcester County Library administrative offices and the Snow Hill branch are located in a 12,000 square foot one-level brick building with a walled garden in Snow Hill. There is no library in Pocomoke City. Churches representing most major denominations are located in the county. Pocomoke City itself has approximately one half dozen churches of various denominations.

Historic Sites

There are nine sites in the vicinity of Pocomoke City which have been identified by the Maryland Historical Trust as being significant to the history of the town and county. These will be submitted for inclusion in the National Register of Historic Places. Two of these sites, the Costen House and Beverly are currently on the National Register.

There are no reported archeological sites in the vicinity of Pocomoke City (within a one mile radius), but it should be noted that a systematic survey of the area has not been conducted. There is a high potential for significant archeological resources in Pocomoke City according to the Maryland Geological Survey.

LAND USE

Existing Land Use

There are 1,213 acres of land and water within the incorporated limits of Pocomoke City. Approximately 62 percent of this area, or 756 acres, has been developed for some type of use. The most extensive type of use in Pocomoke City is residential. This use accounted for 40 percent of the total developed area as shown in Table D-18. The following discussions on existing and future land use are taken from the 1981 Pocomoke City Comprehensive Plan.

TABLE D-18

POCOMOKE CITY LAND USE
(Data Through 1975)

<u>LAND USE TYPE</u>	<u>ACRES</u>	<u>PERCENT OF DEVELOPED AREA</u>
Residential	299	40
Commercial	87	11
Industrial	76	10
Others	294	39
Total	<u>756</u>	<u>100</u>

SOURCE: Pocomoke City Comprehensive Plan, January 1981.

An analysis of the spatial distribution of land uses within the Pocomoke City Planning Area reveals a definite pattern of development within the city and the immediate surrounding area. Concentrated in the heart of town is the Central Business District (CBD), which is the primary center of economic activity within the city's corporate limits. The CBD is situated along two blocks of Market Street from Front Street to Second Street with some spillover southward on Clarke Avenue and Willow Street. However, the downtown Central Business District is currently competing for business activities within the city limits with two relatively new shopping centers located along U.S. Route 13. These secondary commercial activity centers are the Roses Shopping Center at the intersection of Linden Avenue and U.S. Route 13 and the Ames Shopping Center Complex at the intersection of U.S. Route 13 and U.S. Route 113.

Industrial activity within the corporate limits of Pocomoke City is primarily concentrated in an industrial belt extending southward from the railroad along the Pocomoke River and along a small spur extending eastward along the railroad to Fourth Street. The remainder of the land within the corporate limits is devoted primarily to single family homes. However, within the corporate limits there is still a considerable amount of undeveloped property around the edges and on all sides of the built-up sections of the city, especially in the vicinity south of Lynnhaven Drive and the area west of the Homewood Subdivision between Cedar Street and the railroad. The other essential community facilities such as schools, churches and other public and semi-public institutions are spotted throughout the residential areas.

Beyond the corporate limits, strip residential development has occurred along Cedar Hall Road (Route 371) to the south, Old Snow Hill Road (Route 756) to the north and along Old U.S. Route 113. In recent years, there have been substantial new housing starts in the Stockton Road - Groton Road - Buck Harbor Road area to the east of town. Along U.S. Route 13 southward from the corporate limits to the Virginia State line, there is an almost continuous strip of major commercial businesses such as automobile dealerships, large motels, restaurants and other smaller highway oriented businesses such as service stations and fast food restaurants along both the east and west of U.S. Route 13. In addition to these areas, some scattered industrial and business establishments have located along old U.S. Route 113 to the north of town. The remainder of the development within the Pocomoke City Planning Area is primarily rural farm or non-

4.4

farm residential. It is evident that there are numerous areas for urban growth and expansion to the north, east and south of town and particularly for industrial development along the railroad.

After analyzing the existing land use pattern, the fairly compact nature of existing development in Pocomoke City is especially evident. This pattern may be attributed in large part to the availability of city water and sewer facilities. A continued policy of orderly and systematic extension of the water and sewer lines will assist in preventing any undesirable urban sprawl by discouraging scattered developments that are expensive to serve with public utilities. The City should continue to encourage the development of close-in vacant areas where public water and sewer extensions can be installed easily, efficiently and economically.

Future Land Use

A comparison of the land use statistics of Pocomoke City with those of a typical small community indicates that the percentage of residential land to total developed land is almost identical to that of a typical small community. The Pocomoke City Comprehensive Development Plan should focus on an anticipated growth of roughly 35% in the population of Pocomoke City over the next 20 years. This means a total growth of approximately 1,700 persons during the planning period or roughly 23 families per year. In accordance with current trends, it may be assumed that the additional population will reside primarily in single family homes at an average density of 4 - 6 units per acre, which creates a need for a minimum of approximately 95 to 140 acres of residential land to satisfy the residential needs of the anticipated population. The land designated for residential purposes within the corporate limits provides an estimated 1 - 1.5 times the amount of land required for residential use in order to provide a variety of living environments for families to consider in selecting an area to build a home which best suits their individual needs and tastes.

Based on its continuing role as a regional focal point for commercial activity and the possibility of annexing some commercial land along U.S. Route 13, it is anticipated that Pocomoke City's share of commercial activity will continue at a level substantially above those of similar size communities. Therefore, it is recommended that commercial activity within the corporate limits maintain a level of roughly 6 - 10 percent of all development activity throughout the planning period. This would mean the addition of up to 23 acres of commercial land during the next 20 years depending on development demands, and the amount of commercial land that may be annexed. Since the existing number of commercial acres within the town is already approximately 8 percent of the projected total developed community in the year 2000, it is felt that the need for additional commercial land will be minimal during the time frame of the plan and efforts should be directed toward: (1) maximizing the development potential of existing commercial areas within the community by directing new commercial businesses into vacant buildings and redevelopment areas within the downtown area to stimulate the revitalization of the Central Business District and also into already existing shopping centers; and (2) the annexation of commercial land outside the present corporate limits along U.S. Route 13.

From an industrial land use perspective, Pocomoke City appears to be somewhat above the norm of an average community. However, this is somewhat misleading because Pocomoke City cannot be regarded as an average community from an industrial

viewpoint. The Pocomoke City area is currently a major industrial and manufacturing center for the surrounding region and is directly responsible for the employment of over 950 persons in the manufacturing sector of its economy alone. Therefore, it is to be reasonably expected that the industrial sector of the economy should account for a greater percentage of the total developed community than that of comparable communities.

Even though industrial land use presently accounts for over 10 percent of the total developed community, the industrial sector of the economy of Pocomoke City has failed to keep pace with other sectors of the economy over the last ten years. The industrial sector has remained relatively constant, in terms of land use, while the commercial sector has tripled in terms of the percentage of the total community. This lack of any substantial industrial activity within Pocomoke City during the last 10 years as the community's population has steadily increased and the continued loss of the younger working force of the community due to a lack of adequate job opportunities has created a need for a substantial expansion of the industrial sector of the economy during the next 20 years. In an effort to upgrade and expand the industrial sector in hopes of developing a more balanced and diversified economy for the Pocomoke City area and in order to fulfill its designated role in the Worcester County Comprehensive Plan as the industrial center for the county, it is recommended that a minimum of 30 - 80 additional acres of suitable land be developed for industrial purposes within the planning area during the next 20 years. The City has recently taken steps in meeting its future industrial land requirements with the development of approximately 65 acres of industrial property along Broad Street.

In September 1980 a report was published which examined the feasibility of implementing a waterfront redevelopment program in Pocomoke City. This program would build upon the natural amenities of the riverfront area as well as protect the existing openness and accessibility of the waterfront. Another goal of the program would be to tie this new development more closely to the existing Market Street retail and commercial center. The program would involve some residential and commercial development as well as new park and open space features.

ROCK HALL, MARYLAND

DEMOGRAPHIC CHARACTERISTICS

Rock Hall, Maryland, is a small town with a 1970 population of 1,101. It is located in southwestern Kent County, approximately 12 miles southwest of the county seat of Chestertown. The population of Rock Hall, when compared to State totals, is somewhat aged with a median age of 34.9 years and with approximately 50 percent of the population older than 35 years of age. This compares with a state figure of approximately 40 percent of the population 35 years of age or older and a median age of 27.1 years. County figures indicate that approximately 49 percent of the population of Kent County is 35 years of age or older. Historical population trends for Rock Hall, Kent County, the State of Maryland and the U.S. are shown in Table D-19.

TABLE D-19

HISTORICAL POPULATION FOR THE U.S.,
MARYLAND, KENT COUNTY, AND ROCK HALL
(1940-1980)

	<u>1940</u>	<u>1950</u>	<u>1960</u>	<u>1970</u>	<u>1980</u>
UNITED STATES	132,165,000	151,326,000	179,323,000	203,212,000	226,504,825
% change	-	14.5	18.5	13.3	11.5
MARYLAND	1,821,000	2,343,000	3,100,000	3,922,400	4,216,941
% change	-	28.6	32.3	26.5	7.5
KENT COUNTY	13,460	13,680	15,480	16,150	16,695
% change	-	1.6	13.2	4.3	3.4
ROCK HALL	781	786	1,073	1,101	1,511
% change	-	0.6	36.5	2.6	3.7

By 1970, the population of Rock Hall had increased 2.6 percent over the figure for 1960. The population of Kent County increased 4.3 percent and the State figure had increased 26.5 percent over the same period. Total U.S. population over the same period increased 13.3 percent. Population growth in this period in Kent County was markedly lower than that displayed by state or national trends.

Based upon OBERS Series E population projections for the subregion, the estimated population growth for Kent County and for Rock Hall is shown in Table D-20. It should be noted that linear regression techniques applied to the population of Rock Hall yielded a significantly lower population estimate for the year 2020 only.

TABLE D-20

POPULATION PROJECTIONS FOR ROCK HALL AND KENT COUNTY
(1980-2020)

	<u>1980*</u>	<u>1990</u>	<u>2000</u>	<u>2020</u>
Kent County	16,695	18,400	20,000	24,800
Rock Hall (Series E)	1,511	1,450	1,600	2,100
Rock Hall (Regression)	1,571	1,400	1,500	1,800

*The 1980 populations presented for Rock Hall and Kent County are the final counts as determined by the Bureau of the Census.

OCCUPATIONAL DISTRIBUTION

The occupational distribution of Rock Hall is centered in several areas, with the Labor, Sales and Clerical, Services, and Craftwork sectors employing 23.8, 20.7, 20.0 and 17.1 percent of the work force, respectively. This contrasts with the county distribution which indicates that Sales and Clerical constitute 19.4 percent, Professional and Managerial represent 17.7 percent, Laborers constitute 16.3 percent, and the Craftsmen and Foremen constitute 13 percent of the work force. County unemployment in 1970 was 5.9 percent of the work force. Unemployment in the community in 1970 was less than four percent of the work force unemployed. This figure compares with the County and State percentage of 5.9 and 3.2, respectively in Table D-21.

INCOME CHARACTERISTICS

Individual median income in the community of Rock Hall in 1970 was \$1,500, with median family income at approximately \$6,406, and 14.7 percent of the families below the poverty level as shown in Table D-21. Individual median income in the County in 1970 was \$1,630 with a median family income of \$7,636. Only 12.9 percent of the families in the County were defined to be below the poverty level in 1970. Individual median income at the State level in 1970 was significantly higher at \$3,099 with the median family income also significantly higher at \$11,063 with only 7.7 percent of the families below the poverty level. Based upon OBERS Series E per capita income projections, the compound annual growth rate of per capita income for the period 1980-2020 for Rock Hall and Kent County is projected to be 2.9 percent.

EDUCATIONAL CHARACTERISTICS

In 1970, approximately 80 percent of the population aged 25 years or older had not completed high school. This compares with county and state figures of 63 and 48 percent, respectively.

HOUSING CHARACTERISTICS

The number of housing units in Rock Hall in 1970 was 473 with a median gross value of rent of \$74 per month and a median value of owner occupied housing of \$12,359 as shown in Table D-21. County totals valued median gross rent at \$85 per month with a median value of owner occupied homes in 1970 of \$13,100. This contrasts distinctly with state figures of \$127 per month for median gross rent and a median value of owner occupied housing of \$18,800.

INDUSTRIAL EMPLOYMENT

As shown in Table D-22, the majority of employment in Rock Hall occurs in the area of Wholesale and Retail Trade closely followed by the Construction and Manufacturing sectors, with emphasis on marine related activities in this latter category. Note should be made that while employment information on the fisheries sector was not available, this sector is very important to the local economy. The Construction and Manufacturing sectors differ markedly from county and state figures as seen in Table D-22. This may be a function of the skill composition reflected in Table D-21 which indicates a definite lack of professional and technical workers with a rather high proportion of relatively low-skilled workers in both the community and the county.

TABLE D-21

DEMOGRAPHIC AND SOCIO-ECONOMIC CHARACTERISTICS
FOR ROCK HALL, KENT COUNTY, AND MARYLAND
(1970)

<u>DEMOGRAPHIC CHARACTERISTICS</u>	<u>ROCK HALL</u>	<u>KENT COUNTY</u>	<u>MARYLAND</u>
Population	1,101	16,150	3,922,400
Median Age	34.9	29.6	27.1
Percent 35 years or older	50	49.4	40.0
<u>OCCUPATIONAL DISTRIBUTION*</u>			
Prof. Managerial	9.0	17.7	27.6
Craftsmen, Foremen	17.1	13.0	13.7
Operatives (incl. transportation)	8.1	16.8	13.3
Labor (incl. farm)	23.8	16.3	4.6
Farm Managers	1.3	4.8	0.7
Services	20.0	11.6	11.6
Sales and Clerical	20.7	19.4	28.1
Unemployed	3.9	5.9	3.2
<u>INCOME CHARACTERISTICS</u>			
Median Individual Income	\$1,500	\$1,630	\$3,099
Median Family Income	\$6,406	\$7,636	\$11,063
Percent of families below poverty level	14.7	12.9	7.7
<u>EDUCATIONAL CHARACTERISTICS</u>			
Percent of individuals 25 years or older with High School completion	19.7	37.0	52.3
<u>HOUSING CHARACTERISTICS</u>			
Year-round housing units	473	6,049	1,234,469
Median gross value of rent	\$74/month	\$85/month	\$127/month
Median value of owner-occupied housing	\$12,359	\$13,100	\$18,800
Percent of units moved into in last 5 years	38	40.2	52.2

*Based on Percent of Labor Force Aged 16 Years or Older.

TABLE D-22

ROCK HALL 1970 INDUSTRIAL EMPLOYMENT
(Work Force 16 Yrs. or Older)

<u>SECTOR</u>	<u>ROCK HALL (%)</u>	<u>KENT COUNTY (%)</u>	<u>MARYLAND (%)</u>
Construction	15.5	9.3	6.6
Manufacturing	14.2	20.1	19.5
Public Utilities & Transportation	5.8	3.6	6.8
Wholesale & Retail Trade	19.6	18.4	19.2
F.I.R.E. & Repair Services*	4.5	4.9	8.5
Professional & Related Services	8.8	10.6	12.3
Educational Services	4.9	10.1	8.1
Public Administration	3.1	3.6	13.5
Other	23.6	19.1	5.5
Total	<u>100.0</u>	<u>100.0</u>	<u>100.0</u>

*F.I.R.E. is an acronym for Finance, Insurance, and Real Estate.

Though unemployment does not appear to be substantially greater in Kent County than in the State of Maryland, in general, the county work force has been designated since August 1972 as substantially and persistently unemployed by the Department of Commerce Economic Development Administration.

TRANSPORTATION

Railroads

Under an agreement with Penn Central in 1976, the Maryland Department of Transportation (DOT) took over the operation of certain branch lines on the eastern shore of Maryland. DOT in turn entered into several short line operating agreements to have those lines operated under DOT subsidy as the Maryland - Delaware Railroad Company. One of these lines, the Townsend-Chestertown line, serves Chestertown twice weekly and is the closest rail service available to Rock Hall. This line from Chestertown connects with a Conrail line at Townsend, Delaware, for all points north.

Highways

The highway system serving Kent County includes U.S. Route 301, a dual lane highway which crosses the east end of the County and provides a through, north-south route extending from the New Jersey Turnpike across the Chesapeake Bay Bridges and thence southward to Florida. Route 213 is a two lane State highway which runs from the lower east end of the County to the north end of the County and connects with U.S. Route 301 and U.S. Route 50 to the south and U.S. Route 40 to the north. Route 291, a two lane State highway, runs east and west across the County. Route 291 connects with Route 213 and U.S. Route 301 and provides access to Dover, Delaware, and U.S. Route 13.

The basic street system in Rock Hall is formed by Maryland Routes 20 and 445, which connect Rock Hall with the county seat at Chestertown (approximately 15 miles to the east), Tolchester Beach to the north and Eastern Neck to the south. The heaviest traffic flow occurs on Route 20 in the direction of Chestertown where volume approximates 3,000 vehicles per day. Except in the immediate vicinity of Rock Hall itself, most of the streets related to this basic system are discontinuous, dead ending in various waterways and marshy water areas or deteriorating into dirt trails. Many of the residential streets have never been developed and thus much of the land area around the town is inaccessible.

Truck Service

The American Motor Carrier Directory lists 10 motor freight common carriers of general commodities authorized to serve Kent County with truckload and/or less-than-truckload service.

Bus Service

Trailways furnishes Kent County with daily interstate bus service that provides connections with any major point. Both local and long distance schedules are available including through bus service to Philadelphia and New York. Through bus service from Chestertown to New York requires less than four hours travel time.

Water Transportation

Rock Hall Harbor is used extensively by fish and oyster boats with the major commodity shown in Table D-23 to be fish products. The remainder of Kent County's waterways are infrequently used for commercial transportation. Aside from occasional visits by petroleum tankers and grain barges to Chestertown, traffic on the rivers is primarily recreational.

Rock Hall Harbor itself has an approach channel 10 feet in depth and 100 feet wide and measuring 2,000 feet from the entrance through the breakwater to the center of that portion of the channel of the same depth that has been dredged parallel to the harbor terminals. The harbor is extensively developed with marinas, repair yards, marine facilities for the unloading and loading of seafood, an ice manufacturing plant and facilities for obtaining fuel, water, provisions, and motel accommodations.

Outside the harbor itself, much of the shoreline is marshy with water depths of six feet reached only at distances of 500 feet or more from the shore. As a result, only facilities for small boats have been developed in the major marina located outside of the harbor at the end of Rock Hall Road in the Gratitude area. This facility has a restaurant, marine supply store, boat slips, fuel and boat rentals.

The Chester River has a 13-foot channel which permits small oil tankers and grain barges to serve Chestertown. The Port of Cambridge, approximately 50 miles south of Chestertown, is the nearest deepwater port to Kent County. The Port of Baltimore is located approximately 50 miles from Rock Hall.

TABLE D-23

ROCK HALL 1980 WATERBORNE COMMERCE

<u>HARBOR OR WATERWAY</u>	<u>COMMODITY</u>	<u>TONS</u>
Rock Hall Harbor, MD	0911 Fresh Fish, Except Shellfish	63
	0912 Shellfish, Except Prepared	308
Total		<u>371</u>

SOURCE: Waterborne Commerce Statistics of the United States, calendar year 1980, Department of the Army, Corps of Engineers, February 1982.

NOTE: No Commerce was reported in calendar year 1981.

Air Service

Baltimore-Washington International Airport is located approximately 55 miles from Rock Hall. There are more than 300 daily flights providing direct and connecting service to hundreds of domestic and overseas destinations. All scheduled airlines operating at Baltimore-Washington International also carry air freight. In addition, scheduled air-cargo freight service is available between BWI and numerous points.

The Greater Wilmington Airport is approximately 60 miles from Rock Hall. Altair Airlines provides six flights in and out every day. Air freight service is also provided at the Airport. There are two 7,000-foot and two 5,000-foot runways at the Airport. Scheduled air taxi service is available.

COMMUNICATIONS

Postal Facilities

Kent County is served by 11 post offices. The largest is a first class facility in Chestertown. The County also has two second class, five third class and three fourth class offices. Rock Hall itself has a second class post office.

Telephone Services

The Chesapeake and Potomac Telephone Company of Maryland, provides telephone service for the entire County. Nationwide direct distance dialing is one of the services available to customers. Western Union, IT&T and Comsat also provide telecommunications services.

Radio and Television

Radio reception is excellent from Baltimore, Washington, D.C., Philadelphia, Wilmington, Dover and eastern shore stations. There is one radio station in Kent County - WCGR (Chestertown) - which is a 250 watt station. Television reception is excellent on all national networks from Baltimore and Washington, D.C.

Newspapers

There is one weekly newspaper published in Kent County, the Kent County News, with a paid circulation of approximately 7,100. In addition to this newspaper, the County is also served by daily and Sunday papers from Baltimore, Washington, D.C., Wilmington, Philadelphia, and New York.

UTILITIES

Electricity and Gas

The Delmarva Power and Light Company of Maryland supplies electricity to most of the towns and developed areas of the County. The distribution system of the Choptank Electric Cooperative is interconnected with Delmarva Power and Light Company of Maryland and provides electrical service to the rural portions of the County not served by the Delmarva Power and Light Company. Propane gas and fuel oil is available in Kent County from local dealers and distributors.

Water and Sewerage

There are municipal water systems in Betterton, Chestertown, Fairlee, Galena, Kennedyville, and Rock Hall. The Rock Hall water system has a rated plant capacity of 500,000 gallons per day. Water is pumped from three wells and stored in a 125,000 gallon elevated tank. The water distribution system serves all of the present development in the town as well as some of the housing along Route 20 to the east. Outside of the town limits, houses and businesses must rely upon individual on-site wells for their water supply. It appears that the present groundwater resources have sufficient reserve potential to accommodate growth in and near the town to the year 1985.

There are municipal sewerage systems in Betterton, Chestertown, Fairlee, Galena, Kennedyville, Millington, and Rock Hall. Rock Hall's system is the lagoon type. This system provides secondary treatment and has a plant capacity of approximately 250,000 gallons.

COUNTY SERVICES

County police protection is provided by the sheriff and deputies, the Maryland State Police, and municipal police service. The Sheriff has one part time and three full time deputies. The State Police maintains a force in Kent County with headquarters in Chestertown. The municipal police force of Chestertown consists of six full time policemen. Rock Hall also provides police protection.

Fire protection is provided by six volunteer municipal fire departments throughout the county. The six stations are located in Betterton, Chestertown, Galena, Kennedyville, Millington, and Rock Hall. In addition, mutual aid arrangements exist with stations in the communities of Church Hill, Crumpton, Centreville, and Sudlersville in Queen Anne's County, and with Cecilton in Cecil County. Twenty-four hour ambulance service is provided by rescue companies from all of the county fire departments.

The Town of Rock Hall has regular refuse collection twice every week. Most areas of the County contract for service by commercial trash companies. Three county sanitary landfills are available for waste disposal.

EDUCATIONAL SERVICES

The educational program in Kent County includes grades kindergarten-12. There are a total of eight public schools having a total enrollment of approximately 2,700 students. There are three non-public schools in the county with a total estimated enrollment of 230. Rock Hall itself has two schools - one elementary and one high school having a total enrollment of approximately 560 students. These schools are located in the vicinity of Catholic, Main, and Boundary Avenues.

There are a number of institutions providing higher learning in the area. Washington College, a four-year liberal arts and sciences institution, with an enrollment of approximately 800 students, is located in Chestertown. Chesapeake College serves Kent, Queen Anne's and Talbot Counties and has an enrollment of approximately 1,400 students. It is located approximately 22 miles south of Chestertown. Vocational, technical and industrial training programs also exist in the County.

HEALTH SERVICES

Hospital and medical care is provided by a number of institutions. The Kent and Queen Anne's General Hospital is a nonprofit facility located in Chestertown. It is a fully accredited 80 bed facility and provides general medical, surgical, and obstetrical services, emergency room service, and coronary care unit service. The Kent County Health Department located in Chestertown, provides health services for the County in cooperation with the Maryland Department of Health and Mental Hygiene.

CULTURAL INSTITUTIONS

Libraries and Churches

The Kent County Public Library, located in Chestertown, currently operates in a 1,900 square foot facility. The library has a book collection of more than 21,000 volumes. Churches representing most major denominations are located in Kent County. Rock Hall itself possesses several churches of various denominations.

Historic Sites

There are 18 sites in the Rock Hall area which are considered to be of significance to the history of the town and county and which will be submitted for inclusion in the National Register of Historic Places. One of these sites, Hinchingham, is currently listed in the National Register.

In terms of reported archeological sites in the vicinity (approximately a one mile radius) of Rock Hall, the Maryland Geological Survey has indicated that there are six currently reported of medium sensitivity (i.e., may be eligible for inclusion in the National Register). The Maryland Geological Survey also notes that there is a high potential for significant archeological resources within Rock Hall due to its use as a landing in the early 17th century.

LAND USE

Existing Land Use

Early development of Kent County was devoted almost exclusively to the conversion of wooded land to agricultural use. Several early settlements were established on the waterways as shipment points for agricultural products. Those settlements grew into the towns of Chestertown on the Chester River, and Georgetown and Betterton on the Sassafras River. Rock Hall, with a good harbor off the Bay, grew as a center for fishing and boat building.

In general, the development pattern of Kent County is characterized by clusters around towns, widely scattered strips and patches of non-farm residences in the undeveloped areas of the county. Much of the future residential, commercial and industrial development will be encouraged near the towns where public services can most conveniently and economically be provided. The county projects that farm residences will continue to decline.

Existing land use in Kent County is shown in Table D-24. The table indicates that less than seven percent of the total county area is developed. Agriculture occupies by far the greatest percentage of area. It is significant to note that almost as much land is used for streets and roads as for single-family residences. Approximately 25 percent of the total developed residential area lies within, or within one mile of the towns of Chestertown, Rock Hall, Betterton and Millington. Even if the developed area triples by the year 1990, only a very small percentage of the County will be developed.

TABLE D-24

ROCK HALL AND KENT COUNTY LAND USE

<u>TYPE OF LAND USE</u>	<u>KENT COUNTY</u> ¹		<u>ROCK HALL</u> ²	
	<u>ACRES</u>	<u>PERCENT OF DEV. AREA</u>	<u>ACRES</u>	<u>PERCENT OF DEV. AREA</u>
Total Residential	2,888	24.5	104.6	52.0
Total Commercial	443	3.8	8.5	3.5
Total Industrial	152	1.3	9.6	3.0
Public & Semi-Public	5,278	44.8	28.4	10.5
Streets & Roads	2,392	20.3	50.8	31.0

¹ Represents Land Use in Kent County as of 1970.

² Represents Land Use in Rock Hall as of 1965.

The existing land use in Rock Hall for each major category is also shown in Table D-24. The table demonstrates the predominance of residential uses in the community. Residential categories constitute 52 percent of the total of developed land in the planning area. The next largest use of land (exclusive of streets) is the public and semi-public category. Of the total developed land, 48 percent was vacant in 1968. It is important to note that 50 percent of the incorporated area and 86 percent of the planning area is vacant (as of 1968). Much of this vacant land is actually in agricultural use, indicating the importance which agriculture plays in the economic life of the community.

The overall shape of land use is quite disjointed with open spaces scattered throughout. The most obvious limitations on development are imposed by the surrounding bodies of water - the Bay, the Harbor, Swan Creek, and the Haven.

The Main Street central business district consists of developed frontage on both sides of a single block. Typical of the business areas of many small towns, it has grown in a somewhat haphazard fashion over the years, as houses along the street frontage have been converted to commercial usage on their ground floors while continuing residential occupancy upstairs. As expansion of the business area has occurred, it has been in a restricted area along Main Street, with a few scattered establishments on Maryland Route 20 and on Sharp Street. The commercial uses found in the business area are typical of a small community, being oriented toward meeting the daily needs of the populace - food stores, drug stores, variety stores, hardware stores, barber and beauty shops, small restaurants and several service stations. For larger purchases of such items as furniture and appliances, Rock Hall residents must travel to regional shopping areas in Chestertown. The business district has not had much in the way of recent construction outside of two new banks located on Route 20, a liquor store, and several gasoline stations.

Surrounding the commercial core are the older residential areas of town which also include a variety of public and semi-public uses such as town offices and a fire station, post office and several churches. For the most part, these buildings are in good condition.

Industrial land use consists primarily of concentrations of marine-related activities in the area of the intersection of Sharp Street and Chesapeake Avenue. Some expansion of the present area is devoted to seafood packing and processing and boat repair facilities.

Future Land Use

Proposed land use for Rock Hall retains the basic structure of the present community. Commercial activity will continue to be centered along Main Street between Sharp Street and Rock Hall Road. Medium density and high density housing areas surround the commercial core except toward the northeast where there is a proposed industrial area. Moving out from the center of town, housing densities would become lower. On the Gratitude peninsula, medium density housing would be combined with marine oriented commercial uses, with industrial uses of a marine nature located in the Rock Hall Harbor area. Throughout the planning area, many of the marshy areas along the bay front would be retained as permanent open space.

Within Kent County the main goal of the County plan is to concentrate most residential development in the existing towns of Chestertown, Rock Hall, Betterton, and Galena. Non-farm residential construction is to be limited to maintaining the openness of the land. The plan for commercial and industrial development also stresses the concentration of this type of activity within the existing towns. Along Route 20 a sizable area is proposed for the development of services or manufacturing industries which would draw employment from Rock Hall and nearby communities. Among the possible uses which might be accommodated in this area are warehousing, machinery repair, food processing, and other various light manufacturing activities.

ST. MICHAELS, MARYLAND

DEMOGRAPHIC CHARACTERISTICS

St. Michaels, Maryland, is a small town located on the eastern portion of Talbot County, approximately 10 miles west of Easton. In 1970, St. Michaels had an estimated population of 1,470. When compared to County - wide figures, St. Michaels' demographic characteristics are similar. The median age of St. Michaels population was 35.8 years with 51 percent of the population aged 35 years or older. Talbot County figures reflect a 1970 median age of 35.1 years and a population in which 50 percent are age 35 years or older. Both sets of statistics are significantly higher than State figures for these categories. Historical population trends for St. Michaels, Talbot County, Maryland, and the United States are presented in Table D-25.

TABLE D-25

HISTORICAL POPULATION FOR THE U.S., MARYLAND, TALBOT COUNTY, AND ST. MICHAELS (1940-1980)

	<u>1940</u>	<u>1950</u>	<u>1960</u>	<u>1970</u>	<u>1980</u>
UNITED STATES	132,165,000	151,326,000	179,323,000	203,212,000	226,504,825
% change	-	14.5	18.5	13.3	11.5
MARYLAND	18,221,000	2,343,000	3,100,000	3,922,400	4,216,941
% change	-	28.6	32.3	26.5	7.5
TALBOT COUNTY	18,784	19,428	21,578	23,682	25,604
% change	-	3.4	11.1	9.8	8.1
ST. MICHAELS	1,309	1,470	1,484	1,470	1,301
% change	-	12.3	0.9	-0.9	-11.5

As can be seen from Table D-25, population in St. Michaels has exhibited static or decreasing growth since 1950. However, this trend is not the case for Talbot County. Based upon OBERS Series E projections for the subregion, the estimated population

growth for Talbot County and for St. Michaels is shown in Table D-26. Note that linear regressions applied to the population of St. Michaels over the past 40 years yielded a significantly lower population estimate for the year 2020 in particular, with relatively minor differences in other years.

TABLE D-26
POPULATION PROJECTIONS FOR ST. MICHAELS
AND TALBOT COUNTY
(1980-2020)

	<u>1980*</u>	<u>1990</u>	<u>2000</u>	<u>2020</u>
Talbot County	25,604	29,200	32,100	41,100
St. Michaels (Series E)	1,301	1,700	1,800	2,200
St. Michaels (Regression)	1,301	1,600	1,700	1,800

*1980 populations presented for St. Michaels and Talbot County are the final counts as determined by the Bureau of the Census.

OCCUPATIONAL DISTRIBUTION

Occupational distribution in St. Michaels seems to be concentrated in such areas as Craftsmen and Foremen, Services, and Labor. These sectors employ 19.4, 18.6 and 17.3 percent of the work force, respectively. At the County level, the Sales and Clerical category constitutes 20.3 percent of the work force, while Professional and Managerial accounts for 19.5 percent, and Craftsmen and Foremen account for 16 percent of the work force. State figures show that Sales and Clerical workers make up 28.1 percent of the work force, Professional workers represent 27.6 percent and Craftsmen & Foremen constitute 14 percent. Unemployment in the community is very low, at less than three percent of the work force as shown in Table D-27, and seems to be marginally lower in both St. Michaels and Talbot County than in the State.

INCOME CHARACTERISTICS

Individual median income in the community of St. Michaels in 1970 was \$1,916. Median family income was \$7,508 with 13.9 percent of the families below the poverty level as shown in Table D-27. Individual median income for the county in 1970 was \$2,422 with median family income of \$8,073 and 12.5 percent of the families considered to be below the poverty level. Individual median income for the State in 1970 is shown in Table D-27 to be significantly higher at \$3,099 with the median family income also substantially

TABLE D-27

DEMOGRAPHIC AND SOCIO-ECONOMIC CHARACTERISTICS
FOR ST. MICHAELS, TALBOT COUNTY AND MARYLAND
(1970)

<u>DEMOGRAPHIC CHARACTERISTICS</u>	<u>ST. MICHAELS</u>	<u>TALBOT COUNTY</u>	<u>MARYLAND</u>
Population	1,470	23,682	3,922,400
Median Age	35.8	35.1	27.1
Percent 35 years or older	51.0	50.0	40.0
<u>OCCUPATIONAL DISTRIBUTION*</u>			
Prof. Managerial	13.6	19.5	27.6
Craftsmen, Foremen	19.4	16.0	13.7
Operatives (incl. transportation)	15.1	15.2	13.3
Labor (incl. farm)	17.3	10.9	4.6
Farm Managers	0.7	2.6	0.7
Services	18.6	15.3	11.6
Sales & Clerical	15.3	20.3	28.1
Unemployed	2.9	2.5	3.2
<u>INCOME CHARACTERISTICS</u>			
Median Individual Income	\$1,916	\$2,422	\$3,099
Median Family Income	\$7,508	\$8,073	\$11,063
Percent of families below poverty level	13.9	12.5	7.7
<u>EDUCATIONAL CHARACTERISTICS</u>			
Percent of individuals 25 years or older with high school completion	23.7	39.1	52.3
<u>HOUSING CHARACTERISTICS</u>			
Year-round housing units	606	8,907	1,234,469
Median Gross value of rent	\$78/month	\$90/month	\$127/month
Median value of owner-occupied housing	\$12,948	\$16,200	\$18,800
Percent of units moved into in last 5 years	48.3	39.0	52.2

*Based on Percent of Labor Force Aged 16 Years or Older.

higher at \$11,063 with only 7.7 percent of the families defined to be below the poverty level. Based upon OBERS per capita income projections, the compound annual growth rate of per capita income for the period 1980-2020 for St. Michaels and Talbot County is projected to be 2.9 percent.

EDUCATIONAL CHARACTERISTICS

In 1970, approximately 76 percent of the population aged 25 years or older had not completed high school. These figures compare with county totals of 61 percent and State totals of a much lower 48 percent.

HOUSING CHARACTERISTICS

The number of housing units in St. Michaels in 1970 was 606 with a median gross value of rent of \$78 per month and a median value of owner-occupied housing of \$12,948. County figures indicate a median gross value of rent of \$90 per month and a median value of owner-occupied housing of \$16,200 in 1970. These figures are well below the State figures of \$127 per month for median gross rent and \$18,800 for median value of owner-occupied housing.

INDUSTRIAL EMPLOYMENT

As shown in Table D-28, the majority of employment in St. Michaels is in the area of Manufacturing closely followed by Wholesale and Retail Trade and the Construction sectors. Most of the manufacturing in St. Michaels is water-oriented, engaged directly in fishing activity or in marine repair services with Eastern Shore Clam (40) and St. Michaels Oyster (25) being the most significant employers in the area.

TABLE D-28

ST. MICHAELS 1970 INDUSTRIAL EMPLOYMENT (Work Force 16 yrs. or Older)

<u>SECTORS</u>	<u>ST. MICHAELS (%)</u>	<u>TALBOT COUNTY (%)</u>	<u>MARYLAND (%)</u>
Construction	14.5	10.0	6.6
Manufacturing	23.1	16.7	19.5
Public Utilities & Transportation	3.6	5.0	6.8
Wholesale & Retail Trade	17.3	21.6	19.2
F.I.R.E. & Repair Services*	3.3	4.8	8.5
Professional & Related Services	8.7	16.3	12.3
Educational Services	5.2	6.2	8.1
Public Administration	1.8	3.6	13.5
Other	22.6	15.8	5.5
Total	<u>100.0</u>	<u>100.0</u>	<u>100.0</u>

*F.I.R.E. is an acronym for Finance, Insurance, and Real Estate.

County figures shown in Table D-28 reflect a preponderance of Wholesale and Retail Trade employment, with Manufacturing and Professional and Related Services closely behind. State and County figures indicate a much larger proportion of the work force in Professional and Related Services again underscoring this shortcoming at the local level.

TRANSPORTATION

Railroads

Under an agreement with the Penn Central Railroad dated April 1, 1976, Maryland DOT took over the operation of certain branch lines on the eastern shore. Maryland DOT, in turn, entered into several short line operating agreements to have those lines operate as the Maryland - Delaware Railroad Company. Of these lines, the Clayton-Easton line serves Talbot County twice weekly hauling major commodities such as fertilizer and chemicals, feed, field crops, lumber, canned or frozen food and pulpwood. There is at this time no existing or anticipated link to the Town of St. Michaels. Moreover, the continued subsidization of the Clayton-Easton line is questionable if present traffic trends continue.

Highways

The highway system serving Talbot County includes U.S. Route 50, a dual lane highway, which is the major north-south artery through Talbot County. U.S. Route 50 links the eastern shore with the Baltimore-Washington area and points west via the Chesapeake Bay bridges. Headed south, U.S. Route 50 joins U.S. Route 13 and links the eastern shore with Norfolk and southern points via the Chesapeake Bay Bridge-Tunnel. U.S. Route 50 also joins U.S. Route 301 and then onward to the New Jersey Turnpike. There are five Maryland routes which supplement U.S. Route 50 in Talbot County.

Maryland Route 33 runs north-south through St. Michaels and is the only through street in the town. This street connects St. Michaels with Route 50 at Easton to the east and with Tilghman Island to the west. All other north-south streets in St. Michaels eventually dead end. The east-west streets in the town are mostly dead ends as well, either ending at the water's edge or at the railroad right-of-way. Aside from Route 33, St. Michaels has no transportation links with the rest of the state. With the exception of the northwestern portion of the town, the existing streets are in fair condition and are adequate to handle the local traffic.

A 1970 study by the state shows two major projects in the St. Michaels area. The first is the "St. Michaels bypass" and the second is the dualization of Route 33 from Rio Vista to an intersection with Route 50 just north of Easton. As conceived, the bypass would start approximately one mile north of the present town limits bearing to the west and would run roughly along the old railroad right-of-way intersecting Route 33 in the vicinity of Lincoln Avenue in Rio Vista. This proposed dualization of Route 33 could be as much as 20 years in the future.

Truck Service

The American Motor Carrier Directory lists 11 motor freight common carriers of general commodities authorized to serve Talbot County with truckload and/or less-than-truckload service. Trucking service in St. Michaels is on an "as required" basis. This is not likely to change in the foreseeable future.

Bus Service

Trailways provides Talbot County with daily bus service and maintains a terminal in Easton. There are five scheduled daily trips to Washington, D.C. and Baltimore and five daily round trips to Wilmington. There is currently no public transportation in St. Michaels.

Water Transportation

Commodity movements in St. Michaels Harbor are indicated in Table D-29. Understandably, the commodities are exclusively water-oriented.

TABLE D-29

ST. MICHAELS 1981 WATERBORNE COMMERCE

<u>HARBOR OR WATERWAY</u>	<u>COMMODITY</u>	<u>TONS</u>
St. Michaels Harbor, MD	0911 Fresh Fish, except shellfish	4
	0912 Shellfish, except prepared	6,701
	TOTAL	<u>6,705</u>

SOURCE: Waterborne Commerce Statistics of the United States, Calendar Year 1981, Department of the Army, Corps of Engineers, February 1983.

Air Service

Easton Municipal Airport, about two miles north of Easton on U.S. Route 50, has two paved, lighted 4,000-foot runways. Scheduled service to Baltimore and Washington, D.C. is provided by private airline. Facilities and services include fuel, storage and outside tiedown, instruction, rental planes, unicom radio and aircraft maintenance. Accommodations for corporate aircraft are available. There is also a small private airfield located approximately five miles west of St. Michaels.

Baltimore-Washington International Airport is located about 55 miles from Easton. The facility is owned by the Maryland Department of Transportation and managed and operated by its State Aviation Administration. There are an average of 300 flights daily providing air service between BWI and more than 125 North American cities (plus many overseas and foreign destinations) with convenient connecting flights to hundreds of other cities. Washington National Airport, about 70 miles from Easton, has up to 560 scheduled operations (landings and takeoffs) daily. National offers jet and non-jet flights or connections to every major city in the United States.

COMMUNICATIONS

Postal Facilities

Talbot County is served by 16 post offices. The largest of these is the first class office located at Easton. This office has 60 employees and has an annual revenue in excess of \$7,080,000. There are two second class offices located at Oxford and St. Michaels. Thirteen third and fourth class offices are located throughout the County.

Telephone Services

The Chesapeake and Potomac Telephone Company of Maryland, provides telephone service for Talbot County. Nationwide direct distance dialing is available to all customers. Additional suppliers of telecommunications services include Western Union, IT&T, and Comsat.

Radio and Television

WEMD (AM and FM) in Easton is the only radio station in Talbot County. WCEM (AM and FM) in Cambridge is in neighboring Dorchester County. Radio reception is available on all major networks from Baltimore and Washington, D.C. Television reception is available for all major networks from Baltimore, Salisbury, and Washington, D.C. and cable antenna television is available from Cambridge.

Newspapers

There are two daily (Monday through Friday) newspapers published in Easton: The Star Democrat with a circulation of about 10,000 and the Talbot Banner with a circulation of about 11,000. In addition, daily and Sunday papers from Baltimore, Salisbury, and Washington, D.C. and the daily paper from Wilmington, Delaware, have a wide circulation in the County.

UTILITIES

Electricity and Gas

There are four sources of power available in Talbot County. These include the Easton Utilities Commission, the St. Michaels Utilities Commission, the Choptank Electric Cooperative, Inc. and the Delmarva Power and Light Company. The St. Michaels Utilities Commission serves parts of Talbot County and the incorporated town of St. Michaels. Electric power is purchased wholesale from Delmarva Power and Light Company of Maryland. St. Michaels has two substations to serve its present loads, and has purchased land for a third substation site to accommodate future demands.

Natural gas is supplied in the Town of Easton by the Gas Department of the Easton Utilities Commission. The supply of gas is adequate to serve existing loads only. No extensions are being made to the gas system and no additional commercial or industrial customers are being added to the system. Other areas of the County utilize propane gas which is available from local distributors. All grades of fuel oil are available in Talbot County from local distributors.

Water and Sewerage

The towns of Oxford, St. Michaels, and Trappe have central water supply systems supplied by wells. The Aquia Formation is the primary source of water in an area southwest of Easton (including the Bailey's Neck and Oxford Neck areas) and parts of the St. Michaels - Tilghman Neck area. Aquifer characteristics of the Aquia Formation are as follows: the transmissibility is relatively low, ranging from 2,000 to about 5,000 gpd per foot and the permeability is also low, ranging from 45 to 79 gpd per square foot. The Aquia lies 550 to 620 feet below sea level. The waterbearing sands are about 40 to 65 feet thick.

COUNTY SERVICES

Law enforcement agencies in the County include the Sheriff's office, the State Police, and town police departments in Easton, Oxford, St. Michaels, and Trappe. There are seven volunteer fire companies that provide protection for Talbot County. Each company has a Class A rated pumper. All companies are connected by a central alarm system. County-wide ambulance service is available through volunteer fire companies on a 24-hour basis.

Municipal refuse collection is provided within the corporate limits of Easton. The incorporated towns of Oxford, St. Michaels, and Trappe provide refuse collection through commercial contractors. There is a landfill about three miles east of Easton.

EDUCATIONAL SERVICES

There are 10 schools located in Talbot County having a total enrollment of approximately 3,800 students. There are also six non-public schools in the County with a total enrollment of approximately 900 students. The Talbot County Vocational-Technical Center is located in Easton. This facility provides training in areas ranging from mechanics to construction to food services. There are no institutions of higher education located in Talbot County. There are three colleges nearby - Chesapeake College in Queen Anne's County, Washington College in Kent County, and Salisbury State College in Wicomico County.

HEALTH SERVICES

Memorial Hospital at Easton is a completely modern, fully accredited, 200 bed facility. It has a staff of 97 active or consulting physicians and surgeons. The hospital also conducts a 32 month accredited diploma School of Nursing. The Talbot County Health Department is located in Easton. It is an integral unit of the Maryland State Department of Health and Mental Hygiene. The Talbot County Health Department has a Home Health Program available to anyone needing intermittent nursing services or physical therapy. There are two nursing homes in the County. One is located in Easton and one near St. Michaels. There is also an Extended Care Facility at the Memorial Hospital in Easton.

CULTURAL INSTITUTIONS

Libraries and Churches

The Talbot County Free Library is located in the south wing of the Talbot County Courthouse in Easton. The Library houses a collection of some 59,000 books and 1,245 phonograph records, and subscribes to 110 magazines and 8 newspapers. In addition there is a branch library in Oxford with a collection of approximately 4,000 volumes. There is also a special Outreach Reading Room in the Neighborhood Service Center in Easton. A new facility was constructed in 1976. Churches representing most major denominations are located throughout the County. St. Michaels and vicinity has approximately six churches of various denominations.

Historic Sites

There are 13 sites in the St. Michaels vicinity which are considered by the Maryland Historical Trust to be of significance to the history of the town and county and which will be submitted for inclusion in the National Register of Historic Places. Three of these sites, Crooked Intention, Sherwood Manor, and Victorian Corn Cribs are currently listed in the National Register. The Chesapeake Bay Maritime Museum is also located in the Harbor area of St. Michaels and maintains collections which include maritime records, artifacts, and memorabilia.

The Maryland Geological Survey lists no recorded archeological sites in the St. Michaels area (within a one mile radius of the town) but notes that the potential for sites is rather high. The Maryland Geological Survey also notes that there is a high potential for significant archeological resources within St. Michaels.

LAND USE

Existing Land Use

The general pattern of existing zoning in Talbot County calls for agricultural use in the eastern half of the county and mostly waterfront residential usage west of Route 50. Approximately 70 percent of the total county land, or approximately 125,000 acres is farmland. The single largest area of development has occurred in and around the town of Easton. Commercial and industrial land uses have tended for the most part to locate in and around the incorporated towns though there is some scattered industrial use at places such as Cordova.

As can be seen from Table D-30, the majority of land in the St. Michaels planning area is used for residential purposes (44.7 percent). Public and semi-public lands occupy 9.1 percent and streets, railways, and utilities occupy 37.2 percent of the total land in the planning area. Much of the recent residential development in the St. Michaels area has occurred southeast of the town itself in the Rio Vista area. Approximately 28 percent of the town area of St. Michaels is undeveloped with the majority in two areas: vacant land on the west side of the town near the railroad tracks and farm land, and on the north side of town between Talbot Street and the harbor.

TABLE D-30

LAND USE WITHIN CORPORATE LIMITS OF ST. MICHAELS

<u>TYPE OF LAND USE</u>	<u>ACRES</u>	<u>PERCENT OF DEVELOPED AREA</u>
Residential	222.4	44.7
Commercial	18.2	3.6
Industrial	9.3	1.9
Public & Semi-Public	46.0	9.1
Streets, Rails, Utilities	186.7	37.2

St. Michaels commercial activity is situated along both sides of Talbot Street for nearly its entire length, although the highest concentration exists between Mill and Mulberry Streets. This section provides residents with day-to-day shopping needs and services. A second area of commercial activity is located in the vicinity of St. Michaels Harbor and consists of marine-oriented activities such as marinas, boat yards, restaurants and related businesses. There is substantial room for the development of commercial enterprises and efforts to locate such endeavors in other areas will probably be discouraged.

The industrial area in St. Michaels is located in the harbor area which is the center for marine-related industry. Relatively little space has been allocated for industrial development as the geographical location of the town and the small labor market tend to discourage this sort of development.

Future Land Use

Most of the area in St. Michaels proposed for development is for low density residential use. There is provision for a substantial increase in parks, recreation areas, and public and semi-public lands. The growth of the town will depend upon the ability of the local business interests to satisfy the needs of the residents in the general area.

SNOW HILL, MARYLAND

DEMOGRAPHIC CHARACTERISTICS

Snow Hill, Maryland, a small community with a 1970 population of 2,201, is located in the central portion of Worcester County. When compared to the State totals, the Snow Hill population is somewhat aged. The median age of the 1970 Snow Hill population was 33.3 years with 48.3 percent of the town population 35 years of age or older. These statistics compare with a State-wide median age of 27.1 years and 40 percent of the State population aged 35 years or older. County figures indicate a Worcester County median age of 31.5 years with 46.4 percent of the County residents 35 years of age or older. Historical population trends for Snow Hill, Worcester County, the State of Maryland, and the United States are presented in Table D-31.

TABLE D-31

HISTORICAL POPULATION FOR THE U.S., MARYLAND,
WORCESTER COUNTY, AND SNOW HILL
(1940-1980)

	<u>1940</u>	<u>1950</u>	<u>1960</u>	<u>1970</u>	<u>1980</u>
UNITED STATES	132,165,000	151,326,000	179,323,000	203,212,000	226,504,825
% change	-	14.5	18.5	13.3	11.5
MARYLAND	1,821,000	2,343,000	3,100,000	3,922,400	4,216,941
% change	-	28.6	32.3	26.5	7.5
WORCESTER COUNTY	21,245	23,148	23,733	24,442	30,889
% change	-	9.0	2.5	3.0	26.4
SNOW HILL	1,926	2,091	2,311	2,201	2,192
% change	-	8.6	10.5	-4.8	-0.4

Table D-31 indicates that during the decade spanning the period 1960-70, the County population increased only marginally while that of Snow Hill actually decreased. This out-migration of the population of Snow Hill should be cause for concern as those who migrate tend to be younger and better trained members of the community. A region or community which is exporting population tends not only to be exporting capital in the form of local educational services invested in its outmigrants, but is left with a relatively high proportion of non-workers and less productive workers, compounding its economic problems.

Based upon OBERS Series E population projections for the subregion, the estimated populations for Snow Hill and Worcester County are shown in Table D-32. Linear regression techniques applied to historical data of population growth in Snow Hill over the period 1940-70 yielded increasingly significant differences from OBERS Series E projections.

TABLE D-32

POPULATION PROJECTIONS FOR SNOW HILL AND WORCESTER COUNTY

	<u>1980*</u>	<u>1990</u>	<u>2000</u>	<u>2020</u>
Worcester County	30,889	30,700	33,400	41,400
Snow Hill (Series E)	2,192	2,800	3,100	3,800
Snow Hill (Regression)	2,192	2,500	2,600	2,800

*1980 populations presented for Snow Hill and Worcester County are the final counts as determined by the Bureau of the Census.

OCCUPATIONAL DISTRIBUTION

A large portion of the work force in Snow Hill is employed in the Operatives Category (24.1 percent), followed by Sales and Clerical employees (19.9 percent). This contrasts with County figures which indicate a greater percentage of the work force in the Professional and Managerial Category (17.9 percent) as shown in Table D-33. State figures show the Sales and Clerical category to be at 28.1 percent followed closely by the Professional and Managerial group (27.6 percent). Unemployment is shown to be at very low levels in Snow Hill (3.8 percent) but is still higher than both the County and State figures at 3.2 percent of the work force.

INCOME CHARACTERISTICS

Individual median income in the community in 1970 was \$2,166, median family income was \$7,804, and 15 percent of the families were defined to be below the poverty level. This compares favorably with county figures which show individual median income at \$1,697, family median income at \$7,386 and 17.2 percent of the families with income below the poverty level. State levels are still higher at \$3,099 for median individual income and \$11,063 for median family income. The percentage of families defined as below the poverty level State-wide is at 7.7 percent.

EDUCATIONAL CHARACTERISTICS

Figures indicate that in Snow Hill in 1970 approximately 27.9 percent of the population aged 35 years or older had completed high school. This compares unfavorably with a figure of 52 percent for the State of Maryland.

HOUSING CHARACTERISTICS

The number of year-round housing units in Snow Hill in 1970 was 822 with a median gross value of rent of \$82 per month and a median value of owner-occupied housing of \$12,403 as shown in Table D-33. County figures display a median gross value of rent of \$79 per month with a median value of owner-occupied housing of \$11,400. These figures are substantially lower than state figures of \$127 per month as the median gross value of rent and \$18,800 as the median value of owner-occupied housing.

INDUSTRIAL EMPLOYMENT

As shown in Table D-34, almost 35 percent of the Snow Hill work force is employed in the Manufacturing sector. At 14.4 percent of the work force, the Wholesale and Retail Trade sector is a distant second. The distribution of Snow Hill's work force among sectors differs somewhat from the County and the State percentages but similarity is exhibited among the three jurisdictions in that the Manufacturing and Wholesale and Retail Trade sectors are ranked one and two, respectively, in terms of percentage of labor force employed.

TABLE D-33

DEMOGRAPHIC AND SOCIO-ECONOMIC CHARACTERISTICS
FOR SNOW HILL, WORCESTER COUNTY, AND MARYLAND
(1970)

<u>DEMOGRAPHIC CHARACTERISTICS</u>	<u>SNOW HILL</u>	<u>WORCESTER COUNTY</u>	<u>MARYLAND</u>
Population	2,201	24,442	3,922,400
Median Age	33.3	31.5	27.1
Percent 35 years or older	48.3	46.4	40.0
<u>OCCUPATIONAL DISTRIBUTION*</u>			
Prof. Managerial	17.9	17.9	27.6
Craftsmen, Foremen	15.5	15.1	13.7
Operatives (incl. transportation)	24.1	17.5	13.3
Labor (incl. farm)	5.4	13.3	4.6
Farm Managers	2.1	4.1	0.7
Services	15.1	15.1	11.6
Sales and Clerical	19.9	16.7	28.1
Unemployed	3.8	3.2	3.2
<u>INCOME CHARACTERISTICS</u>			
Median Individual Income	\$2,166	\$1,697	\$3,099
Median Family Income	\$7,804	\$7,386	\$11,063
Percent of families below poverty level	15.0	17.2	7.7
<u>EDUCATIONAL CHARACTERISTICS</u>			
Percent of individuals 25 years or older with High School completion	27.9	32.3	52.3
<u>HOUSING CHARACTERISTICS</u>			
Year-round housing units	822	8,962	1,234,469
Median gross value of rent	\$82/month	\$79/month	\$127/month
Median value of owner-occupied housing	\$12,403	\$11,400	\$18,800
Percent of units moved into in last 5 years	36.8	38.1	52.2

*Based on Percent of Labor Force Aged 16 Years or Older.

TABLE D-34

SNOW HILL 1970 INDUSTRIAL EMPLOYMENT
(Work Force 16 Years or Older)

<u>SECTORS</u>	<u>SNOW HILL(%)</u>	<u>WORCESTER COUNTY (%)</u>	<u>MARYLAND (%)</u>
Construction	5.2	9.9	6.6
Manufacturing	34.9	22.3	19.5
Public Utilities & Transportation	2.8	4.4	6.8
Wholesale & Retail Trade	14.4	18.1	19.2
F.I.R.E. & Repair Services*	7.8	6.5	8.5
Professional & Related Services	7.6	8.3	12.3
Educational Services	8.6	4.3	8.1
Public Administration	9.7	5.2	13.5
Other	9.1	21.0	5.5
Total	100.0	100.0	100.0

*F.I.R.E. is an acronym for Finance, Insurance, and Real Estate.

TRANSPORTATION

Railroads

The Snow Hill Shippers Association provides freight service for Worcester County and Snow Hill as well. There are 14 rail users in the county of which the Snow Hill area accounts for 8. There are two to three trains per week in the county though there is no rail passenger service.

Highways

The highway system serving Worcester County includes U.S. Route 13, which extends northward to Wilmington and the New Jersey Turnpike and southward through the Virginia portion of the eastern shore and connects with the Chesapeake Bay Bridge-Tunnel to Norfolk. U.S. Route 113 crosses the County and joins U.S. Route 13 at Pocomoke City. Long-range plans of the State Highway Administration are that U.S. Route 113 be dualized for its entire length through the County as a limited access expressway. U.S. Route 50 which has its eastern terminus at Ocean City links the eastern shore with the Baltimore-Washington area and points west via the Chesapeake Bay Bridges.

The main thoroughfares in Snow Hill are Market Street (U.S. Route 113), Church Street (Maryland Route 12 east), West Washington Street (Maryland Route 12 west) and Bay Street (Maryland Route 365). The town is designed in a generally rectangular pattern based upon a few major roads which radiate outward from the business center. The town has a network of short streets with Federal Street and Market Street the only two streets which cross the town.

Truck Service

The American Motor Carrier Directory lists 10 motor freight common carriers of general commodities authorized to serve Worcester County with truckload and/or less-than-truckload service.

Bus Service

Trailways provides Worcester County with daily bus service through which connections with any major point are available.

Water Transportation

The Port of Cambridge is the nearest deepwater port and is located about 50 miles northwest of Snow Hill. The Port of Baltimore is about 125 miles from Snow Hill. Snow Hill is at the head of navigation on the Pocomoke River. The channel has an authorized depth of nine feet and a width of 100 to 130 feet. As seen in Table D-35 below, in calendar year 1981 the Pocomoke River was used primarily for barge transportation of wood and petroleum products to private terminals at Snow Hill. There is also a basin for small pleasure boats in Byrd Park, but little use is made of it.

TABLE D-35

POCOMOKE RIVER 1981 WATERBORNE COMMERCE

<u>HARBOR OR WATERWAY</u>	<u>COMMODITY</u>	<u>TONS</u>
Pocomoke River, MD.	2416 Wood Chips, Staves, Moldings	123,637
	2911 Gasoline	10,772
	2914 Distillate Fuel Oil	8,248
	TOTAL	142,657

SOURCE: Waterborne Commerce Statistics of the United States, Calendar Year 1981, Department of the Army, Corps of Engineers, February 1983.

Air Service

The Ocean City Municipal Airport is located about 20 miles northeast of Snow Hill and has a 3,400-foot paved runway which is lighted from dusk to dawn. There is scheduled commuter service to Baltimore-Washington International Airport (BWI) near Baltimore and to Dulles International Airport west of Washington, D.C.

The Salisbury-Wicomico County Airport is located about 15 miles northwest of Snow Hill. The U.S. Air Commuter has an average of about 28 flights daily to BWI near Baltimore, Washington National Airport, and Philadelphia International Airport.

COMMUNICATIONS

Postal Facilities

Worcester County is served by 10 post offices. There are four Class I offices located in Berlin, Ocean City, Pocomoke City, and Snow Hill. City delivery is provided for the residents in the Class I office locations.

Telephone Services

The Chesapeake and Potomac Telephone Company of Maryland provides telephone service in Worcester County. Direct distance dialing is available to all customers. The county seat, Snow Hill, is included in the local calling area for every exchange in Worcester County. Telecommunications services are also provided by Western Union, IT&T and Comsat.

Radio and Television

There are three radio stations in Worcester County. WBOC (AM & FM) has a studio in Ocean City as well as in Salisbury in Wicomico County. WDMV (AM) is located in Pocomoke City and WETT (AM) is located in Ocean City. The nearest commercial television station is WBOC-TV in Salisbury which has a network hookup with ABC, CBS, and NBC. In addition, there is a cable TV system available in all the incorporated towns in Worcester County.

Newspapers

There are three weekly newspapers published in Worcester County: the Eastern Shore Times in Ocean City with a circulation of about 4,000, the Maryland Coast Press in Ocean City with a circulation of about 4,650, and the Worcester County Messenger in Pocomoke City with a circulation of about 3,700. In addition to these newspapers, daily and Sunday papers from Baltimore, Philadelphia, Salisbury, Washington, D.C., and Wilmington have a wide circulation.

UTILITIES

Electricity and Gas

Delmarva Power and Light Company supplies electricity to most of the towns and developed areas in Worcester County. Choptank Electric Cooperative, Inc. provides electrical service to a large portion of rural Worcester County. The distribution system of Choptank Electric Cooperative is interconnected with Delmarva Power and Light Company. Independent municipal propane gas systems are available in Berlin, Ocean City, Pocomoke City, and Snow Hill.

Water and Sewerage

There are municipal water systems in Berlin, Newark, Ocean City, Pocomoke City, and Snow Hill. The municipal system of Snow Hill consists of two main wells with each pumping 550 gpm, an auxiliary well which pumps 380 gpm, and an overhead storage tank which has a capacity of 220,000 gallons.

There are municipal sewerage systems in Berlin, Newark, Ocean City, Pocomoke City, and Snow Hill. Snow Hill has a combined sewerage system with practically all properties connected. The primary sewage treatment plant was constructed in 1965. It is located on Cypress Lane and has a 330,000 gpd capacity. The capacity of the sewage treatment plant is projected to be inadequate for growth through the year 1990.

COUNTY SERVICES

Law enforcement agencies in Worcester County include town police forces in Berlin, Pocomoke City, Snow Hill, and Ocean City. The Snow Hill Police Department has a chief and six officers. Fire protection is provided by several volunteer fire companies located in the incorporated towns. Snow Hill's volunteer company has ample fire fighting equipment and also provides ambulance service on a 24-hour basis. Snow Hill also provides its residents with regular refuse collection.

EDUCATIONAL SERVICES

There are 13 schools located in Worcester County with a total enrollment of approximately 5,000 students. Snow Hill has one elementary school, one middle school, and one high school. The total enrollment in 1974 of all three schools was approximately 1900 students. In the 1973-74 school year, Snow Hill accounted for 28.2 percent of the total enrollment in the County. There are three non-public schools located in Worcester County with an enrollment of approximately 360 students.

There are no institutions of higher learning located in Worcester County. There are two colleges nearby - Salisbury State College in Wicomico County and the University of Maryland, Eastern Shore Campus in Somerset County. Salisbury State College is a fully accredited four year liberal arts college located approximately 18 miles from Snow Hill. The University of Maryland, Eastern Shore is also a fully accredited four year public college in Princess Anne in Somerset County. There is also a county Vocational Center which offers training in eight trades and occupations.

HEALTH SERVICES

There is no hospital in Worcester County. The majority of the County's citizens utilize the Peninsula General Hospital in Salisbury, about 18 miles from Snow Hill. It is community-owned with 370 beds and a staff of over 90 physicians and surgeons. Public health services are provided through the Worcester County Health Department with offices and clinics maintained in Snow Hill, Pocomoke City, and Berlin. There are two nursing homes in Worcester County with a total bed capacity of 48.

CULTURAL INSTITUTIONS

Libraries and Churches

The Worcester County Library has its administrative office and the Snow Hill branch in a new 12,000 square foot one-level brick building with a walled garden in Snow Hill. Churches representing most major denominations are located in Worcester County. Snow Hill itself has approximately six churches of various denominations.

Historic Sites

There are approximately 40 sites in the vicinity of Snow Hill which are considered by the Maryland Historical Trust to be of significance to the history of the town and county and which will be submitted for inclusion in the National Register of Historic Places. One of these, the Nassawango Iron Furnace site, is currently listed on the National Register. Snow Hill also possesses the Julia A. Purnell Museum which contains John Wilkes Booth's weapon of assassination.

In terms of reported archeological sites in the vicinity (within a one mile radius of the town) of Snow Hill, the Maryland Geological Survey has indicated that there are two areas of medium sensitivity (i.e., may be eligible for inclusion in the National Register). It should be noted that Snow Hill is one of the oldest towns in Maryland and possesses a high potential for significant archeological resources.

LAND USE

Existing Land Use

As seen in Table D-36 the dominant land use in the town of Snow Hill is residential. The majority of Snow Hill's housing supply was built prior to World War II and consists generally of one or two story frame, single family homes. Most of the units which appear to be in need of improvement are clustered near the commercial center northwest of Market Street near Byrd Park.

TABLE D-36

SNOW HILL EXISTING LAND USE (1974)

<u>LAND USE TYPE</u>	<u>ACRES</u>	<u>PERCENT WITHIN CORPORATE LIMITS</u>
Residential	250	61.0
Commercial	15	3.9
Industrial & Utilities	54	13.9

The central business district consists of the downtown shopping district along Market, Green, Washington, and adjacent streets. This is the dominant shopping center in central Worcester County. Adjoining this core is a fringe of auto sales and service dealers, public buildings, churches, small industries and some fine old homes. The principal area of industrial development is along the main railroad track from its terminal north to Purnell Branch outside of the town.

Future Land Use

The Comprehensive Plan for Snow Hill recommends that not less than four percent of the future town be allocated to commercial use. Industries and transportation should have approximately 15 percent of the total area, with recreation and other needs occupying approximately 10 percent. This would mean approximately 30 acres for commercial use, 120 acres for industrial use, 86 acres for parks and playgrounds and 67 acres for public and semi-public buildings.

It is the expressed intent of the Comprehensive Plan to keep the shopping area intact, with the frontage of Green, Washington, Pearl and Bank Streets reserved for principal stores, shops and business offices. The intention is to cluster the shopping facilities into a close knit group for maximum convenience. The plan provides more space for primary business buildings than currently is available by gradually relocating the non-shopping or general business establishments elsewhere including the auto sales and service places, used car lots and certain state and county offices. It is planned to relocate downtown offices of governmental agencies in a new government building park along the waterfront. It is also proposed that a traffic-free pedestrian plaza or mall be constructed along Pearl Street from Market to Green Street.

In June 1982, a Waterfront Redevelopment Study was conducted for the community of Snow Hill. The study area extended from Washington Street to the West side of Byrd Park, and from the river to Market Street with the exception of the downtown commercial area. The purpose of this study was to examine opportunities for development of the waterfront, in order to take advantage of some of the most valuable real estate in the area, and also to support the downtown. The elements of the study included interviews with key citizens, the distribution of an attitude survey, field surveys of existing constraints and opportunities, a series of public meetings, the coordination of goals and objectives statements, a brief market analysis, and the preparation of alternative design concepts.

TILGHMAN ISLAND, MARYLAND

DEMOGRAPHIC CHARACTERISTICS

Tilghman Island is a small community located in the southwesternmost part of Talbot County. It had a 1970 population of 1,180 with a median age of 34.6 years. Almost 50 percent of the community's population was 35 years of age or older. This compares to Talbot County's median age figure of 35.1 years with 50 percent of the County population age 35 years or older.

Information on population trends on Tilghman Island is sketchy. Available data indicate that the population grew from 804 to 1,180 in the period 1960-1970. Some demographic information is available for the Bay Hundred area which includes the area from Claiborne to Blackwalnut Point. Historical trends for this area are compared with county, state and national trends in Table D-37. As indicated, population in the Bay Hundred area has shown a net decrease since 1950.

Based upon OBERS Series E population projections for the subregion, the estimated population growth for Talbot County is shown in Table D-38. Because of the unavailability of data for the Tilghman Island area, regression techniques were applied to the population of the Bay Hundred area using data for the past 40 years. Based upon this regression analysis, projections of populations for the area through the year 2020 are also displayed in Table D-38.

TABLE D-37

HISTORICAL POPULATION FOR THE U.S., MARYLAND,
TALBOT COUNTY, AND BAY HUNDRED
(1940-1980)

	<u>1940</u>	<u>1950</u>	<u>1960</u>	<u>1970</u>	<u>1980</u>
UNITED STATES	132,165,000	151,326,000	179,323,000	203,212,000	226,504,825
% change	-	14.5	18.5	13.3	11.5
MARYLAND	1,821,000	2,343,000	3,100,000	3,922,400	4,216,941
% change	-	28.6	32.3	26.5	7.5
TALBOT COUNTY	18,784	19,428	21,578	23,682	25,604
% change ^c	-	3.4	11.1	9.8	8.1
BAY HUNDRED	2,033	2,201	1,957	1,975	1,927
% change	-	8.3	-11.1	0.9	-2.4

TABLE D-38

POPULATION PROJECTIONS FOR THE
TILGHMAN ISLAND AREA AND TALBOT COUNTY
(1980-2020)

	<u>1980*</u>	<u>1990</u>	<u>2000</u>	<u>2020</u>
Talbot County	25,604	29,200	32,100	41,100
Bay Hundred (Regression)	1,927	2,200	2,200	2,300

*1980 populations presented for Bay Hundred and Talbot County are the final counts as determined by the Bureau of the Census.

OCCUPATIONAL DISTRIBUTION

The occupational distribution of Tilghman Island is highly concentrated among some very low paying, low-skilled occupations, with 39.7 percent and 24.0 percent of the work force aged 16 years or older employed in the Operatives and Labor sectors, respectively. The island work force lacks professional and technical workers as well as clerical and kindred workers as shown in Table D-39. Partially because of this imbalance, the labor force would not be very attractive to many industries. These figures contrast with county figures shown in Table D-39 which indicate a larger share of workers in the Sales and Clerical and the Professional and Managerial categories. State figures in Table D-39 also emphasize the Sales and Clerical and Professional and Managerial categories.

TABLE D-39

DEMOGRAPHIC AND SOCIO-ECONOMIC CHARACTERISTICS
FOR TILGHMAN ISLAND, TALBOT COUNTY, AND MARYLAND
(1970)

<u>DEMOGRAPHIC CHARACTERISTICS</u>	<u>TILGHMAN ISLAND</u>	<u>TALBOT COUNTY</u>	<u>MARYLAND</u>
Population	1,180	23,682	3,922
Median Age	34.6	35.1	27.1
Percent 35 years or older	49.6	50.0	40.0
<u>OCCUPATIONAL DISTRIBUTION*</u>			
Prof. Managerial	9.8	19.5	27.6
Craftsmen, Foremen	10.2	16.0	13.7
Operatives (incl. transportation)	39.7	15.2	13.3
Labor (incl. farm)	24.0	10.9	4.6
Farm Managers	0.8	2.6	0.7
Services	11.4	15.3	11.6
Sales and Clerical	4.1	20.3	28.1
Unemployed	2.7	2.5	3.2
<u>INCOME CHARACTERISTICS</u>			
Median Individual Income	\$2,399	\$2,422	\$3,099
Median Family Income	\$6,214	\$8,073	\$11,063
Percent of families below poverty level	7.9	12.5	7.7
<u>EDUCATIONAL CHARACTERISTICS</u>			
Percent of individuals 25 years or older with High School completion	12.5	39.1	52.3
<u>HOUSING CHARACTERISTICS</u>			
Year-round housing units	525	8,907	1,234,469
Median gross value of rent	\$65/month	\$90/month	\$127/month
Median value of owner-occupied housing	\$9,340	\$16,200	\$18,800
Percent of units moved into in last 5 years	37.1	39.0	52.2

*Based on Percent of Labor Force Aged 16 Years or Older.

INCOME CHARACTERISTICS

Individual median income for Tilghman Island residents in 1970 was \$2,399 while median family income was \$6,214. Based on family income, 7.9 percent of the families on Tilghman Island were below the poverty level. The county-wide individual median income figure of \$2,422 was comparable to the local community. The county median family income figure was \$8,073 and the percentage of families below the poverty level was 12.5 percent. State figures on income are significantly higher than those for the community and the county while the percentage of families, statewide, below the poverty level is slightly lower at 7.7 percent. This information is also presented in Table D-39.

EDUCATIONAL CHARACTERISTICS

In 1970 only 12.5 percent of the population aged 25 years or older had completed high school. County figures fared somewhat better at 39.1 percent while the State scored even higher with 52.3 percent of this category having completed high school.

HOUSING CHARACTERISTICS

The number of year-round housing units in Tilghman in 1970 was 525 with a median gross value of monthly rent of \$65 and a median value of owner-occupied housing of \$9,340. Figures for Talbot County are significantly higher at \$90 for the median gross value of monthly rent and \$16,200 as the median value of owner-occupied housing. State figures exceeded both community and County figures. The State figure for median gross value of monthly rent in 1970 is shown in Table D-39 to be \$127, and \$18,800 is given as the median value of owner-occupied housing.

INDUSTRIAL EMPLOYMENT

As seen in Table D-40, the majority of those aged 16 years or older on Tilghman are employed in the Manufacturing sector. It should be stressed that this sector is exclusively water-oriented. This compares with county figures which show a concentration in the Wholesale and Retail Trade category. State figures indicate almost equal shares in the Manufacturing and Wholesale and Retail Trade sectors with the Public Administration sector also contributing a large share.

TRANSPORTATION

Railroads

Under agreement with the Penn Central Railroad dated April 1, 1976, Maryland DOT took over the operation of certain branch lines on the eastern shore. Maryland DOT, in turn, entered into several short line operating agreements to have those lines operate as the Maryland-Delaware Railroad Company. Of these lines, the Clayton-Easton line serves Talbot County twice weekly hauling major commodities such as fertilizer and chemicals, feed, field crops, lumber, canned or frozen food and pulpwood. Moreover, the continued subsidization of the Clayton-Easton line is questionable if present traffic trends continue.

TABLE D-40

TILGHMAN ISLAND 1970 INDUSTRIAL EMPLOYMENT
(Work Force 16 Years or Older)

<u>SECTORS</u>	<u>TILGHMAN ISLAND (%)</u>	<u>TALBOT COUNTY (%)</u>	<u>MARYLAND (%)</u>
Construction	7.9	10.0	6.6
Manufacturing	25.7	16.7	19.5
Public Utilities & Transportation	2.4	5.0	6.8
Wholesale and Retail Trade	10.8	21.6	19.2
F.I.R.E. & Repair Services*	0.0	4.8	8.5
Professional & Related Services	3.9	16.3	12.3
Educational Services	4.1	6.2	8.1
Public Administration	5.9	3.6	13.5
Other	39.3	15.8	5.5
Total	100.0	100.0	100.0

*F.I.R.E. is an acronym for Finance, Insurance, and Real Estate.

Highways

The highway system serving Talbot County includes U.S. Route 50, a dual lane highway, which is the major north-south artery through Talbot County. U.S. Route 50 links the eastern shore with the Baltimore-Washington area and points west via the Chesapeake Bay bridges. In a southerly direction, U.S. Route 50 joins U.S. Route 13 and links the eastern shore with Norfolk and southern points via the Chesapeake Bay Bridge-Tunnel. U.S. Route 50 also joins U.S. Route 301 which provides connections to the New Jersey Turnpike. There are five Maryland routes which supplement U.S. Route 50 in Talbot County.

Maryland Route 33 connects Tilghman Island with St. Michaels to the east and with Route 50 at Easton. Because of the land area involved, streets in the town are short, dead-ending at the water's edge, with Route 33 the only access into or out of Tilghman. Most streets in the town are in fair condition and are adequate to handle the small quantity of local traffic.

Truck Service

The American Motor Carrier Directory lists 11 motor freight common carriers of general commodities authorized to serve Talbot County with truckload and/or less-than-truckload service. Trucking service in St. Michaels is on an "as required" basis. This is not likely to change in the foreseeable future.

Bus Service

Trailways provides Talbot County with daily bus service and maintains a terminal in Easton through which connections with any major point are available.

Water Transportation

The Port of Cambridge, which is about 15 miles south of Easton, is the nearest deepwater port to Talbot County. The Port of Baltimore is about 59 miles from Easton. As to be expected, the major commodity group involved in traffic at Knapps Narrows in calendar year 1981 was fish products as indicated in Table D-41.

Air Service

Easton Municipal Airport, about two miles north of Easton on U.S. Route 50, has two paved, lighted 4,000-foot runways. Scheduled service to Baltimore and Washington, D.C. is provided by private airline. Facilities and services include fuel, storage and outside tiedown, instruction, rental planes, unicom radio and aircraft maintenance. Accommodations for corporate aircraft are available. There is also a small private airfield located approximately five miles west of St. Michaels.

TABLE D-41

KNAPPS NARROWS 1981 WATERBORNE COMMERCE

<u>HARBOR OR WATERWAY</u>	<u>COMMODITY</u>	<u>TONS</u>
Knapps Narrows, MD.	0911 Fresh Fish, except shellfish	9
	0912 Shellfish, except prepared	16,227
	0931 Marine Shells, unmanufactured	1,120
	TOTAL	17,356

SOURCE: Waterborne Commerce Statistics of the United States, Calendar Year 1981, Department of the Army, Corps of Engineers, February 1983.

COMMUNICATIONS

Postal Facilities

Talbot County is served by 16 post offices. The largest of these is the first class office located at Easton. There are two second class offices located at Oxford and St. Michaels. Thirteen third and fourth class offices are located throughout the County. Tilghman Island has one third class post office.

Telephone Services

The Chesapeake and Potomac Telephone Company of Maryland provides telephone service for Talbot County. Nationwide direct distance dialing is available to all customers. Additional suppliers of telecommunications services include Western Union, IT&T, and Comsat.

Radio and Television

WEMD (AM and FM) in Easton is the only radio station in Talbot County. WCEM (AM and FM) in Cambridge is in neighboring Dorchester County. Radio reception is available on all major networks from Baltimore and Washington, D.C. Television reception is available for all major networks from Baltimore, Salisbury, and Washington, D.C. and cable antenna television is available from Cambridge.

Newspapers

There are two daily (Monday through Friday) newspapers published in Easton: The Star Democrat with a circulation of about 10,000 and the Talbot Banner with a circulation of about 11,000. In addition, daily and Sunday papers from Baltimore, Salisbury, and Washington, D.C. and the daily paper from Wilmington, Delaware, have a wide circulation in the County.

UTILITIES

Electricity and Gas

There are four sources of power available in Talbot County to include the Easton Utilities Commission, Delmarva Power and Light Company, the Choptank Electric Cooperative, Inc. and the St. Michaels Utilities Commission. The St. Michaels Utilities Commission serves parts of Talbot County and the incorporated town of St. Michaels. Electric power is purchased wholesale from Delmarva Power and Light Company of Maryland.

Natural gas is supplied in the Town of Easton by the Gas Department of the Easton Utilities Commission. The supply of gas is adequate to serve existing loads only. No extensions are being made to the gas system and no additional commercial or industrial customers are being added to the system. Other areas of the county utilize propane gas which is available from local distributors. All grades of fuel oil are available in Talbot County from local distributors.

Water and Sewerage

The Aquia Formation occurs in western Talbot County and is the primary source of water in an area southwest of Easton (including the Bailey's Neck and Oxford Neck areas) and parts of the St. Michaels - Tilghman Neck area. Aquifer characteristics of the Aquia Formation are as follows: the transmissibility is relatively low, ranging from 2,000 to about 5,000 gpd per foot and the permeability is also low, ranging from 45 to 79 gpd per square foot. The Aquia lies 550 to 620 feet below sea level. The waterbearing sands are about 40 to 65 feet thick. The original static water level was at least a few feet above sea level, and thus about 550 feet of drawdown was available to the first wells completed in the formation. The Aquia is capable of supplying moderately large quantities of water in the Easton area in spite of its low transmissibility. Most sewerage is handled by private septic systems on the island.

COUNTY SERVICES

Law enforcement agencies in the county include the Sheriff's office, the State Police, and town police departments in Easton, Oxford, St. Michaels, and Trappe. There are seven volunteer fire companies that provide protection for Talbot County. Each company has a Class A rated pumper. All companies are connected by a central alarm system. County-wide ambulance service is available through volunteer fire companies on a 24-hour basis. Municipal refuse collection is provided within the corporate limits of Easton. The incorporated towns of Oxford, St. Michaels, and Trappe provide refuse collection through commercial contractors. There is a landfill about three miles east of Easton.

EDUCATIONAL SERVICES

There are 10 schools in the area with a total enrollment in 1981 of approximately 3,800 students. The Talbot County Vocational-Technical Center is located in Easton. This facility provides training in areas ranging from mechanics to construction to food services. There are also six non-public schools within the County enrolling approximately 900 students. The Talbot County Board of Education also offers a program in adult continuing education, enrolling approximately 550 adults in over 20 courses throughout the County.

There are no institutions of higher learning located within Talbot County. There are however three colleges nearby: Chesapeake College in Queen Anne's County, Washington College in Kent County, and Salisbury State College in Wicomico County.

HEALTH SERVICES

Memorial Hospital at Easton is a completely modern, fully accredited, 200 bed facility. It has a staff of 97 active or consulting physicians and surgeons. The hospital also conducts a 32 month accredited diploma School of Nursing. The Talbot County Health Department is also located in Easton. It is an integral unit of the Maryland State Department of Health and Mental Hygiene. The Talbot County Health Department has a Home Health Program available to anyone needing intermittent nursing services or physical therapy. There are two nursing homes in the county. One is located in Easton and one near St. Michaels. There is also an Extended Care Facility at the Memorial Hospital in Easton.

CULTURAL INSTITUTIONS

Libraries and Churches

The Talbot County Free Library is located in the south wing of the Talbot County Courthouse in Easton. The Library houses a collection of some 59,000 books and 1,245 phonograph records, and subscribes to 110 magazines and 8 newspapers. In addition there is a branch library in Oxford with a collection of approximately 4,000 volumes and a special Outreach Reading Room in the Neighborhood Service Center in Easton. A new facility was constructed in 1976. Churches representing most major denominations are located in the County. Tilghman Island itself has several churches of various denominations.

Historic Sites

There are two sites in the Tilghman Island vicinity which are considered by the Maryland Historical Trust to be of significance to the history of the town and county and which will be submitted for inclusion in the National Register of Historic Places. One skipjack, the Reliance, is currently located off Knapps Narrows and is included in the National Register.

There are no recorded archeological sites in the vicinity of Tilghman Island (within a one mile radius), but it should be noted that a systematic survey of the area has not been conducted. According to the Maryland Geological Survey, there is a high potential for significant archeological resources in the Tilghman area.

LAND USE

The general pattern of existing zoning in Talbot County calls for agricultural use of the eastern half of the county and mostly waterfront residential usage west of Route 50. Approximately 70 percent of the total County land, or approximately 125,000 acres is farmland. The single largest area of development has occurred in and around the town of Easton. Commercial and industrial land is generally located in and around the incorporated towns though there is some scattered industrial use at places such as Cordova.

The majority of land on Tilghman Island is used for residential purposes. The condition of most residences on the island is good, with one rather low value area located on Mission Road west of Route 22 and another similar area generally along Route 33. As one approaches the water, the condition of the housing in the area seems to improve.

Commercial establishments in Tilghman Island are located in the area immediately adjacent to Knapps Narrows with another area of moderately concentrated commercial activity located along Route 33 heading south from Knapps Narrows. These areas include a few service stations, an auto repair garage, a few grocery stores, three restaurants, two novelty and gift shops, one bank, and one hardware store. The condition of most of these establishments is fair to good. The restaurants are all very well maintained and seem more oriented toward visitors to the island than to the local population.

VIRGINIA FLOOD-PRONE COMMUNITIES

CAPE CHARLES, VIRGINIA

DEMOGRAPHIC CHARACTERISTICS

Between 1970 and 1980, Northampton County gained 183 persons while the town lost 266 (a 10.5 percent decline over 1970). Several agencies have projected changes in future population. Two of these are shown in Table D-42 below with their sources noted. No agency has made projections for Cape Charles. However a contribution of existing circumstances would suggest little or no growth in population.

TABLE D-42

NORTHAMPTON COUNTY HISTORICAL AND PROJECTED
POPULATION (1970 - 2030)

<u>SOURCE</u>	<u>1970(a)</u>	<u>1980(a)</u>	<u>1990</u>	<u>2000</u>	<u>2010</u>	<u>2020</u>	<u>2030</u>
Department of Planning and Budget Jan 1983(b)	14,442	14,625	15,000	15,300	15,600	15,900	16,200
Regional Economic Analysis Division - Bureau of Economic Analysis(c)	14,442	14,625	15,271	16,113	17,018	18,062	18,681

- (a) U.S. Department of Commerce, Bureau of Census, 1970 & 1980 Census of Population, Vol. 1. August 1982.
 (b) Population Projections - Virginia Counties and Cities, 1980 - 2000.
 (c) County-Level Projections of Economic Activity and Population Virginia, 1985 - 2040, U.S. Department of Commerce, December 1982.

INCOME CHARACTERISTICS

Seasonal unemployment, together with low wages and salaries, contribute to a high level of poverty. Thus 1970 median family income was less than one-half the state's, and approximately one-third of Northampton County's families were below poverty level. Many of these families were either elderly or black.

The Tayloe-Murphy Institute of Virginia counted 3,999 families in 1978, with median income of \$10,503 (57 percent of the state level). Among 136 counties, this placed Northampton 135th, even though median income in constant dollars increased 23.5 percent between 1969 and 1978. Based on Department of Commerce OBERS statistics, real dollar per capita income should reach 68.4 percent of state levels by 2030. In 1969 it was 59.5 percent of the state level.

HOUSING AND MUNICIPAL SERVICES

The 1980 Census counted 701 housing units in Cape Charles with a median value of \$22,900. Of these, 312 were owner occupied.

The nearest elementary school to Cape Charles is in Capeville. The town does have a police department, emergency ambulance service, voluntary fire company, and library. While the county has a public health department and hospital, there is a shortage of private and public health facilities and services.

HAMPTON ROADS, VIRGINIA

DEMOGRAPHIC CHARACTERISTICS

Since 1970, the net increase in the study area population has been due to growth in Chesapeake and Virginia Beach. Table D-43 shows historical population and the Virginia Department of Planning and Budget's projections for the five cities. Table D-44 shows study area population projections from another source as well as projections for the two SMSA's in which the area is located.

Table D-43

VIRGINIA DEPARTMENT OF PLANNING AND
BUDGET POPULATION PROJECTIONS FOR HAMPTON ROADS

<u>CITY</u>	<u>1970</u>	<u>1980</u>	<u>1990</u>	<u>2000</u>	<u>2010</u>	<u>2020</u>	<u>2030</u>
Hampton	120,777	122,617	124,900	127,000	128,800	130,400	132,000
Norfolk	307,951	266,979	245,500	240,000	240,000	240,000	240,000
Portsmouth	110,963	104,577	99,200	96,800	96,800	96,800	96,800
Chesapeake	89,580	114,486	142,000	162,500	179,000	193,300	207,600
Va. Beach	172,106	262,199	352,300	417,500	476,000	530,000	584,000
Total	801,379	870,858	963,900	1,043,800	1,120,600	1,190,500	1,260,400

TABLE D-44

HAMPTON ROADS COMPARATIVE POPULATION PROJECTIONS

<u>SOURCE</u>	<u>1970</u>	<u>1980</u>	<u>1990</u>	<u>2000</u>	<u>2010</u>	<u>2020</u>	<u>2030</u>
Department of Planning & Budget (a)	801,379	870,858	963,900	1,043,800	1,120,600	1,190,500	1,260,400
OBERS County Level (b)	801,379	870,858	966,472	1,046,359	1,122,060	1,199,046	1,247,209
Two SMSA's (VA portion) (c) OBERS-Low Change-in-Share	-	1,160,311	1,272,311	1,374,701	-	-	1,639,795

- (a) Population Projections-Virginia Counties and Cities, 1980-2000, January 1983.
- (b) County Level Projections of Economic Activity and Population Virginia, 1985-2040, Regional Economic Analysis Division, Bureau of Economic Analysis, December 1982.
- (c) 1980 OBERS BEA Regional Projections, Economic Activity in the United States, Vol. 8, Region 5, Bureau of Economic Analysis, July 1981.

All sources in Table D-44 project the population to grow between 41 and 44.5 percent from 1980 to 2030. The greatest increases in population are anticipated for Chesapeake and Virginia Beach. Norfolk and Portsmouth are projected to show modest growth by OBERS and a decline by the Department of Planning and Budget.

The population within the study area has been getting older over the past decade. The percentage of population under 18 years of age decreased from 34.8 percent to 28.5 percent between 1970 and 1980; the 18 to 64 year-olds have increased from 59.3 to 64.1 percent. Those 65 and older increased from 5.9 to 7.4 percent.

INCOME CHARACTERISTICS

Per capita income for the cities in the study area ranged between \$7,251 and \$8,238 and ranked in the lower three-fifths of Virginia's incorporated cities. The 1979 income is shown in Table D-45. OBERS projects per capita income in the area's two SMSA's to increase two percent per year.

TABLE D-45

HAMPTON ROADS PER CAPITA INCOME

<u>CITY</u>	<u>PER CAPITA 1979</u>	<u>CITY RANK</u>
Chesapeake	\$7,251	37
Hampton	7,875	29
Norfolk	7,463	34
Portsmouth	7,466	33
Va. Beach	8,238	25

SOURCE: Tayloe-Murphy Institute.

HOUSING CHARACTERISTICS

There were 307,245 housing units in the study area in 1980, 306,359 of which were year-round units. Seventy-seven percent of all year-round units were single family. Owners occupied 166,306 total units. Norfolk had the largest percentage of multifamily dwellings (33 percent) and Chesapeake the smallest (14.5 percent). The median value of houses as estimated by their owners ranged from \$36,600 in Portsmouth to \$58,500 in Virginia Beach.

EMPLOYMENT CHARACTERISTICS

OBERS total employment for the five-city area is projected to increase from 418,774 to 597,519 or 42.7 percent between 1978 and 2030. Table D-46 shows these projections by city. OBERS projections for employment in the two SMSA's are shown in Table D-47. The largest increases over the 1978-2030 period were projected for Services at 88 percent, Wholesale and Retail Trade at 75 percent, and Manufacturing at 45 percent. The importance of Government, Trade, and Services to the economy is demonstrated in Table D-48.

TABLE D-46

PROJECTED EMPLOYMENT FOR THE HAMPTON ROADS AREA

<u>CITY</u>	<u>1978</u>	<u>1990</u>	<u>2000</u>	<u>2010</u>	<u>2020</u>	<u>2030</u>
Hampton	35,013	66,103	72,236	76,886	78,336	79,853
Norfolk	206,306	227,054	242,774	256,279	260,793	265,657
Portsmouth	50,470	58,775	63,549	67,344	68,582	69,871
Chesapeake	27,835	36,899	40,817	43,547	44,228	44,983
Va. Beach	79,150	109,441	122,672	131,690	134,388	137,155
Total	<u>418,774</u>	<u>498,272</u>	<u>542,048</u>	<u>575,746</u>	<u>586,327</u>	<u>597,519</u>

SOURCE: County-Level Projections of Economic Activity and Population: Virginia, 1985-2040.

TABLE D-47

OBERS EMPLOYMENT PROJECTIONS

<u>SMSA</u>	<u>1978</u>	<u>1985</u>	<u>1990</u>	<u>2000</u>	<u>2030</u>
Norfolk-Virginia Beach-Portsmouth	334,651	428,469	453,510	492,817	543,080
Newport News- Hampton	<u>172,224</u>	<u>195,123</u>	<u>207,642</u>	<u>227,011</u>	<u>251,215</u>
TOTAL	556,875	623,592	661,152	719,818	794,295

SOURCE: 1980 OBERS BEA Regional Projections.

TABLE D-48

OBERS COUNTY LEVEL
EMPLOYMENT BY SECTOR FOR FIVE-CITY AREA¹
(1978)

<u>Employment</u>	<u>Percent</u>
Total Government (incl. military)	40.6
Wholesale and Retail Trade ²	18.4
Services	18.0
Total Manufacturing	6.3
Contract Construction	5.9
Percent of Total Employment	<u>89.2</u>

¹ Includes Hampton, Norfolk, Portsmouth, Chesapeake, and Virginia Beach.

² Does not include wholesale trade for Chesapeake and Portsmouth.

There are several large government installations in the study area. In Portsmouth, the Norfolk Naval Shipyard was the city's largest employer, accounting for 41 percent of the civilian labor force in 1971. Hampton has a large concentration of military and civilian Federal personnel at Langley Air Force Base and the National Aeronautics and Space Agency. The Fifth Naval District is headquartered in Norfolk, where the Naval Supply Center, Public Works Center, and Naval Air Station are among the large operations.

POQUOSON, VIRGINIA

DEMOGRAPHIC CHARACTERISTICS

Poquoson has been one of the fastest growing cities in Virginia over the past 20 years. While the surrounding population of York County grew at an estimated 6.8 percent between 1970 and 1980, and that of Newport News - Hampton SMSA at 9.4 percent, Poquoson's population increased 60.4 percent. Projections for these areas are shown in Table D-49.

The proportion of Poquoson's population between 18 and 64 years old increased from 55.8 percent in 1970 to 60.5 percent in 1980. The increase in this working age group is evidence of the immigration which has occurred because Poquoson acts as a residential suburb for the nearby metropolitan area.

Normally such population growth as Poquoson has had can be expected to be accompanied by industrial and commercial development. That has not proven to be the case in Poquoson. Thus, the city is having to provide the services demanded by a rapidly increasing population of all income groups and is forced to rely not on a diversified local tax base but almost completely on residential real property taxation and intergovernment revenues.

OCCUPATIONAL DISTRIBUTION

Residents generally commute to jobs in either Newport News, Hampton, or York County. The total number of residents employed has increased steadily since 1960. Individuals employed increased over 33 percent between 1976 and 1978 from 2,532 to 3,385. Consequently, unemployment rates have remained low. Within the city, the number of employed grew from 468 in 1976 to 572 in 1978. The largest single employer during these years was local government, accounting for nearly one-half of Poquoson's jobs.

Currently, there are no large industrial or commercial establishments in Poquoson. Of those industries having five or more employees, the majority were engaged in seafood packing or processing. Other commercial employment sectors in 1980 included Retail and Wholesale Trade (160 employees), Services (69), and Contract Construction (58). Despite the lack of available jobs within the city, the labor force is skilled and well educated. Median school years increased from 9.4 in 1960 to 11.1 in 1970. Many of Poquoson's professional workers are employed in public and private research facilities at or near the Langley Air Force Base, including NASA, LTV Aerospace Corporation, Wyle Laboratories, and Hayes International.

TABLE D-49

POPULATION PROJECTIONS FOR POQUOSON,
YORK COUNTY, AND THE NEWPORT NEWS-HAMPTON SMSA

PLACE/SOURCE	Historical ¹		1990	2000	2010	2020	2030
	1970	1980					
Poquoson-DSPB ²	5,441	8,726	11,900	14,500	16,400	17,900	19,400
Poquoson-OBERS ³	5,441	8,726	9,774	10,595	11,372	12,131	12,616
York County-DSPB ²	27,762	35,463	42,500	47,300	51,000	54,100	57,200
Newport News-Hampton SMSA-DSPB ²	333,463	364,449	393,700	415,500	432,600	446,900	461,200
Newport News-Hampton SMSA-OBERS ⁴	333,140	364,449	408,982	444,185	—	—	531,228

¹Actual values are final census counts.

²Virginia Population Projections 2000, Department of Planning and Budget, Richmond, Virginia, January, 1983. Adjusted to account for Poquoson's independent city status on June 1, 1975.

³County-Level Projections of Economic Activity and Population, Virginia, 1985-2040, Regional Economic Analysis, U.S. Department of Commerce, December, 1982.

⁴1980 OBERS BEA Regional Projections, Volume 8, Region 5, Southeast, U.S. Department of Commerce, Bureau of Economic Analysis, July, 1981.

INCOME CHARACTERISTICS

Family income increased at all levels between 1960 and 1970. According to the Tayloe-Murphy Institute, there were 2,440 families in Poquoson in 1978 with a median income of \$19,531, or 106 percent of the State median figure. The city ranked 17th out of 136 counties and cities with respect to this measure of income. The change in constant dollars over the 1969 median was 16.2 percent. Per capita income in 1977, however, was only 77 percent of the State level, or \$5,250.

HOUSING CHARACTERISTICS

According to a city housing census, there were 2,885 housing units as of 1980. Approximately 22 percent of these units have either structural deficiencies, lack of adequate plumbing and sanitary facilities, overcrowding, or combinations of these problems. An estimated 1,099 residential building permits were issued between 1970 and the third quarter of 1979. Almost all of these permits were for private, single-family structures.

The current housing supply fails to meet the city's needs despite the number of units offered and the stability of the local housing market. Approximately 48.1 percent of the city's population is within the category of low to moderate income. Over 60 percent of these persons reside in the Trinity area, within the eastern precinct. This area has most of the city's oldest residences. The average value of street-front properties in that area is less than one-half the average value of all improved and unimproved properties in the city as a whole.

TANGIER ISLAND, VIRGINIA

While there is current information published for Accomack County, little of it is for Tangier alone or can be useful in understanding life on the island. The population is predominantly methodist and the two churches play an important part in community life. There is a Health Center with a registered nurse and an accredited school for kindergarten through high school even though there may be only a dozen students graduating from high school in any year. A community center with basketball courts and eating facilities was recently built on a pile foundation at a northwest site on the island. Local people characterize their life as a tranquil one. They can walk or bike easily to any part of town and those who want cars keep them parked in places like Crisfield for use on the mainland.

WEST POINT, VIRGINIA

DEMOGRAPHIC CHARACTERISTICS

West Point's population of 2,726 in 1980 was slightly over 29 percent of King William County's population of 9,334. There are two sources of projected population for King William County shown in Table F-50, along with historical figures. If West Point maintained the average growth it has exhibited over the last decade (0.47 percent per year between 1970-1980), it would reach 3,450 persons by 2030.

TABLE D-50

KING WILLIAM COUNTY HISTORICAL AND PROJECTED POPULATION (1970-2030)

<u>Source</u>	<u>1970</u> ¹	<u>1980</u> ¹	<u>2000</u>	<u>2020</u>	<u>2030</u>
Department of State Planning and Budget, January 1983 ²	7,497	9,334	12,600	14,500	15,400
Bureau of Economic Analysis, December 1982 ³	7,497	9,334	10,269	11,583	11,970

¹ 1980 Census of Population, Volume 1, U.S. Department of Commerce, Bureau of Census, August 1982.

² Population Projections - Virginia Counties and Cities, 1980-2000.

³ County-Level Projections of Economic Activity and Projections, Virginia, 1985-2040, U.S. Department of Commerce, December 1982.

OCCUPATIONAL DISTRIBUTION

The number of West Point residents employed in 1970 was 39 percent of the total number of county residents employed, irrespective of place of work. Since 1970 the number of employed persons living within the county increased over 22 percent, reaching 3,467 in 1978. Unemployment that year was 5.8 percent. Manufacturing, with 1,314 employees, accounted for 51 percent of all the county's nonagricultural wage and salary jobs in 1978. About 94 percent of these manufacturing employees were in the paper and lumber industries, which are located chiefly in West Point. By 2020 approximately 4,500 persons are expected to be employed in the county. Employment and earnings in paper and allied products will continue to be of major importance to the county's economy.

INCOME CHARACTERISTICS

In 1970, 10.6 percent of all persons and 7.5 percent of all families below the poverty level resided in the town. Per capita income for King William County was between 80 and 88 percent of the national figure throughout the 1970's and is expected to maintain that relative position through 2020. In 1978, the county ranked 45th out of 136 counties and cities in Virginia with respect to median family income, that being \$17,106.

HOUSING CHARACTERISTICS

About 31 percent of the county's year-round housing units are in West Point. In 1980, the town had 980 occupied units, 736 of them owner occupied. Their median value was estimated at \$41,300 and only 3.1 percent lacked plumbing for their exclusive use.

TRANSPORTATION

Railroads

A division of the Norfolk Southern Railway runs from West Point to Danville via Richmond. Daily scheduled freight service is available on this line with north-south or east-west connections made at either Richmond or Danville.

Highways

State Highway 30 runs the entire length of King William County from northwest to southeast, providing access from West Point to Interstate 95 via U.S. 301 and State Route 54. In addition, Route 33 provides a direct interchange with Interstate 64, which passes approximately 12 miles south of the town.

Bus Service

The southern portion of King William County is served by Cavalier Transportation Company operating over State Route 33 and providing trips daily each way between the Trailways Terminal in Richmond and West Point, Matthews, Deltaville, and other towns of the "Middle Peninsula." Connections for distant travel may be made at Richmond.

Water Transportation

Chartered oceangoing vessels drawing 18 feet of water navigate safely the length of the York River to just above West Point. Barges and other shallow-draft vessels use the Pamunkey and Mattaponi Rivers. All of the rivers are also used for fishing and pleasure boating.

REFERENCES

Background Studies, Talbot County, Maryland, Comprehensive Planning Program, Urban Pathfinders, Inc., January 1973.

Background Study for Worcester County, Urban Pathfinders, Inc., Baltimore-Washington International Airport, August 1974.

Brief Industrial Facts, Dorchester County, Maryland, Maryland Department of Economic and Community Development, Division of Business and Industrial Development, January 1983.

Brief Industrial Facts, Kent County, Maryland, Maryland Department of Economic and Community Development, Division of Business and Industrial Development, Annapolis, Maryland, January 1983.

Brief Industrial Facts, Somerset County, Maryland, Maryland Department of Economic and Community Development, Division of Business and Industrial Development, Annapolis, Maryland, January 1983.

Brief Industrial Facts, Talbot County, Maryland, Maryland Department of Economic and Community Development, Division of Business and Industrial Development, Annapolis, Maryland, January 1983.

Brief Industrial Facts, Worcester County, Maryland, Maryland Department of Economic and Community Development, Division of Business and Industrial Development, Annapolis, Maryland, January 1983.

Community Economic Inventory, Dorchester County, Maryland, Maryland Department of Economic and Community Development, Division of Business and Industrial Development, Annapolis, Maryland, April 1975.

Community Economic Inventory, Kent County, Maryland, Maryland Department of Economic and Community Development, Division of Business and Industrial Development, Annapolis, Maryland, June 1977.

Community Economic Inventory, Somerset County, Maryland, Maryland Department of Economic and Community Development, Division of Business and Industrial Development, Annapolis, Maryland, April 1975.

Community Economic Inventory, Worcester County, Maryland, Maryland Department of Economic and Community Development, Division of Business and Industrial Development, Annapolis, Maryland, June 1976.

Community Economic Inventory, Talbot County, Maryland, Maryland Department of Economic and Community Development, Division of Business and Industrial Development, Annapolis, Maryland, May 1976.

The Comprehensive Development Plan, Pocomoke City, Maryland, Pocomoke City Planning Commission and Maryland Department of State Planning, Pocomoke City, Maryland, January 1981.

The Comprehensive Development Plan, St. Michaels, Maryland, St. Michaels Planning and Zoning Commission, 1971.

The Comprehensive Development Plan, Snow Hill, Maryland, January 1976.

The Comprehensive Plan, The City of Cambridge, Jacob F. Frego and Robert L. Dodd, July 1978.

Comprehensive Plan for Crisfield, Maryland, Armiger, Chaffin and Associates, Inc., Columbia, Maryland, June 1976.

The Comprehensive Plan, Dorchester County, Maryland, Comprehensive Planning Program, Urban Pathfinders, Inc., Baltimore, Maryland, November 1974.

The Comprehensive Plan for Kent County, Maryland, Volumes I and II, Prepared 1968 by Harland, Bartholomew & Associates, updated 1974 by Peter L. Johnston.

The Comprehensive Plan for Rock Hall, Maryland, Harland, Bartholomew & Associates, Washington, DC, November 1968 (updated 1974).

Comprehensive Plan for Somerset County, Maryland, Stottler, Stagg and Associates, May 1975.

The Comprehensive Plan, Talbot County, Maryland, Comprehensive Planning Program, Urban Pathfinders, Inc., October 1973.

General Housing Characteristics, Maryland, Census of Housing, US Bureau of the Census, August 1982.

General Housing Characteristics, Virginia, Census of Housing, US Bureau of the Census, August 1982.

Historic Snow Hill, Snow Hill Bicentennial Committee, Snow Hill, Maryland, 1976.

Preliminary Report, Community Facilities and Financial Studies, Comprehensive Plan, Rock Hall, Maryland, February 1967, Harland, Bartholomew & Associates.

Volume I and Measurements Reports, Series GE No. 1, US Bureau of the Census, 1970.

Waterborne Commerce of the United States, Calendar Year 1980, Part 1, Department of the Army, Corps of Engineers, February 1982.

Waterborne Commerce of the United States, Calendar Year 1981, Part 1, Department of the Army, Corps of Engineers, February 1983.

The Worcester County Comprehensive Plan, Urban Pathfinders, Inc., and William Small Associates, Severna Park, Maryland, February 1976.

CHESAPEAKE BAY
TIDAL FLOODING STUDY

APPENDIX E
ENGINEERING DESIGN AND COST ESTIMATES

Department of the Army
Baltimore District, Corps of Engineers
Baltimore, Maryland
September 1984

CHESAPEAKE BAY TIDAL FLOODING STUDY

APPENDIX E - ENGINEERING DESIGN AND COST ESTIMATES

TABLE OF CONTENTS

<u>Item</u>	<u>Page</u>
Introduction	E-1
Stage-Frequency Information	E-1
Engineering Design	E-3
Structural Measures	E-3
Floodwalls	E-3
Flood Levees	E-3
Steel Sheet Pile Bulkhead	E-20
Nonstructural Measures	E-20
Raising of Structure	E-20
Utility Room Addition	E-21
Relocation of Structure	E-21
Acquisition and Demolition	E-21
Floodproofing	E-24
Flood Shields	E-24
Floodwalls	E-24
Flood Control Plan Cost Estimates	E-27
Maryland Communities	E-29
Cambridge	E-30
Crisfield	E-40
Pocomoke City	E-48
Rock Hall	E-55
Snow Hill	E-67
St. Michaels	E-76
Tilghman Island	E-82
Virginia Communities	E-91
Cape Charles	E-91
Structural	E-91
Nonstructural	E-91
Hampton Roads	E-95
Structural	E-95
Nonstructural	E-95
Poquoson	E-98
Structural	E-98
Nonstructural	E-98
Tangier Island	E-102
Structural	E-102
Nonstructural	E-104
West Point	E-107
Structural	E-107
Nonstructural	E-107

LIST OF FIGURES

<u>Number</u>	<u>Title</u>	<u>Page</u>
E-1	Cambridge Stage-Frequency Relationship	E-4
E-2	Crisfield Stage-Frequency Relationship	E-5
E-3	Pocomoke City Stage-Frequency Relationship	E-6
E-4	Rock Hall Stage-Frequency Relationship	E-7
E-5	Snow Hill Stage-Frequency Relationship	E-8
E-6	St. Michaels Stage-Frequency Relationship	E-9
E-7	Tilghman Island Stage-Frequency Relationship	E-10
E-8	Cape Charles Stage-Frequency Relationship	E-11
E-9	Hampton Roads Stage-Frequency Relationship	E-12
E-10	Poquoson Stage-Frequency Relationship	E-13
E-11	Tangier Island Stage-Frequency Relationship (CORPS)	E-14
E-12	Tangier Island Stage-Frequency Relationship (VIMS)	E-15
E-13	West Point Stage-Frequency Relationship (CORPS)	E-16
E-14	West Point Stage-Frequency Relationship (VIMS)	E-17
E-15	Typical Wall Section	E-18
E-16	Typical Levee Section	E-19
E-17	First Floor Raising	E-22
E-18	Utility Room Addition	E-23
E-19	Flood Shield Installation and Storage Scheme	E-25
E-20	Gravity Floodwall	E-26
E-21	Typical Gravity Floodwall Cross Section	E-28

LIST OF TABLES

<u>Number</u>	<u>Title</u>	<u>Page</u>
E-1	Tidal Flood-Prone Communities: Maryland and Virginia	E-27
E-2	Cambridge Cost Summary for Structural Plan CA-1	E-31
E-3	Cambridge Cost Summary for Structural Plan CA-2	E-32
E-4	Cambridge Cost Summary for Structural Plan CA-3	E-33
E-5	Cambridge Cost Summary for Structural Plan CA-4	E-34
E-6	Cambridge Cost Summary for Structural Plan CA-5	E-35
E-7	Cambridge Cost Summary for Structural Plan CA-6	E-36
E-8	Cambridge Cost Summary for Nonstructural Plan CA-7	E-37
E-9	Cambridge Cost Summary for Nonstructural Plan CA-8	E-38
E-10	Cambridge Flood Control Alternatives: Estimates of Annual Equivalent Charges	E-39

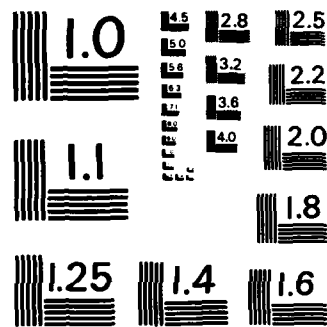

MICROCOPY RESOLUTION TEST CHART
NATIONAL BUREAU OF STANDARDS-1963-A

LIST OF TABLES (Cont'd)

<u>Number</u>	<u>Title</u>	<u>Page</u>
E-11	Crisfield Cost Summary for Structural Plan CR-1	E-41
E-12	Crisfield Cost Summary for Structural Plan CR-2	E-42
E-13	Crisfield Cost Summary for Structural Plan CR-3	E-43
E-14	Crisfield Cost Summary for Structural Plan CR-4	E-44
E-15	Crisfield Cost Summary for Nonstructural Plan CR-5	E-45
E-16	Crisfield Cost Summary for Nonstructural Plan CR-6	E-46
E-17	Crisfield Flood Control Alternatives: Estimates of Annual Equivalent Charges	E-47
E-18	Pocomoke City Cost Summary for Structural Plan PC-1	E-49
E-19	Pocomoke City Cost Summary for Structural Plan PC-2	E-50
E-20	Pocomoke City Cost Summary for Nonstructural Plan PC-3	E-51
E-21	Pocomoke City Cost Summary for Nonstructural Plan PC-4	E-52
E-22	Pocomoke City Cost Summary for Nonstructural Plan PC-5	E-53
E-23	Pocomoke City Flood Control Alternatives: Estimates of Annual Equivalent Charges	E-54
E-24	Rock Hall Cost Summary for Structural Plan RH-1	E-56
E-25	Rock Hall Cost Summary for Structural Plan RH-2	E-57
E-26	Rock Hall Cost Summary for Structural Plan RH-3	E-58
E-27	Rock Hall Cost Summary for Structural Plan RH-4	E-59
E-28	Rock Hall Cost Summary for Structural Plan RH-5	E-60
E-29	Rock Hall Cost Summary for Structural Plan RH-6	E-61
E-30	Rock Hall Cost Summary for Nonstructural Plan RH-7	E-62
E-31	Rock Hall Cost Summary for Nonstructural Plan RH-8	E-63
E-32	Rock Hall Cost Summary for Nonstructural Plan RH-9	E-64
E-33	Rock Hall Cost Summary for Nonstructural Plan RH-10	E-65
E-34	Rock Hall Flood Control Alternatives: Estimates of Annual Equivalent Charges	E-66
E-35	Snow Hill Cost Summary for Structural Plan SH-1	E-68
E-36	Snow Hill Cost Summary for Structural Plan SH-2	E-69
E-37	Snow Hill Cost Summary for Structural Plan SH-3	E-70
E-38	Snow Hill Cost Summary for Structural Plan SH-4	E-71
E-39	Snow Hill Cost Summary for Nonstructural Plan SH-5	E-72
E-40	Snow Hill Cost Summary for Nonstructural Plan SH-6	E-73
E-41	Snow Hill Cost Summary for Nonstructural Plan SH-7	E-74
E-42	Snow Hill Flood Control Alternatives: Estimates of Annual Equivalent Charges	E-75
E-43	St. Michaels Cost Summary for Structural Plan SM-1	E-77
E-44	St. Michaels Cost Summary for Structural Plan SM-2	E-78
E-45	St. Michaels Cost Summary for Nonstructural Plan SM-3	E-79
E-46	St. Michaels Cost Summary for Nonstructural Plan SM-4	E-80
E-47	St. Michaels Flood Control Alternatives: Estimates of Annual Equivalent Charges	E-81

LIST OF TABLES (Cont'd)

<u>Number</u>	<u>Title</u>	<u>Page</u>
E-48	Tilghman Island Cost Summary for Structural Plan TI-1	E-83
E-49	Tilghman Island Cost Summary for Structural Plan TI-2	E-84
E-50	Tilghman Island Cost Summary for Structural Plan TI-3	E-85
E-51	Tilghman Island Cost Summary for Structural Plan TI-4	E-86
E-52	Tilghman Island Cost Summary for Nonstructural Plan TI-5	E-87
E-53	Tilghman Island Cost Summary for Nonstructural Plan TI-6	E-88
E-54	Tilghman Island Cost Summary for Nonstructural Plan TI-7	E-89
E-55	Tilghman Island Flood Control Alternatives: Estimates of Annual Equivalent Charges	E-90
E-56	Nonstructural Measures Considered for Cape Charles, Virginia	E-92
E-57	Cape Charles Nonstructural Plan Average Annual Costs	E-94
E-58	Structural and Nonstructural Measures Considered for Hampton, Virginia	E-96
E-59	Hampton Average Annual Cost Computation	E-97
E-60	Nonstructural Measures Considered for Poquoson, Virginia	E-99
E-61	Poquoson Average Annual Nonstructural Cost Computation	E-101
E-62	Cost of Floodwalls on Tangier to the 100-Year Corps Tidal Flood Stage	E-102
E-63	Cost of Protecting the Tangier School	E-103
E-64	Nonstructural Measures Considered for Tangier, Virginia	E-104
E-65	Annual Costs of Structural and Nonstructural Plans on Tangier Island	E-106
E-66	Nonstructural Measures Considered for West Point, Virginia	E-108
E-67	West Point Average Annual Nonstructural Cost Computation	E-110

APPENDIX E

ENGINEERING DESIGN AND COST ESTIMATES

INTRODUCTION

Several detailed studies were undertaken in an effort to fulfill the goals and objectives of the Chesapeake Bay Program. One of these studies involved the examination of the effects of tidal flooding in the Chesapeake Bay Region. Specifically, this study identified communities potentially impacted by a flood that is tidal in origin. Preliminary plans were then developed for avoiding or minimizing the effects of tidal flooding. The purpose of this appendix is to describe the assumptions upon which the preliminary plans were based and to provide estimates of costs associated with construction and implementation of these plans. Included in this presentation will be a discussion of the stage-frequency information used in the hydrologic analysis, a discussion of the types of measures considered as well as the cost of these measures, a discussion of the Stage II results (leading to more detailed work by the Norfolk District) and finally, a presentation of the cost estimates by plan for each of the communities examined.

STAGE-FREQUENCY INFORMATION

Generally, serious tidal flooding in the Chesapeake Bay Region is caused by storms which are classified as either tropical or extratropical in nature. The tropical storms and hurricanes are those storms which originate in the lower latitudes and move northward into the Bay Region. They are characterized by rather high winds which generate non-uniform surges and local extremes in flood heights due to locally intense cells of low pressure in combination with variable shoreline configurations and water depths. Extratropical storms or "northeasters," on the other hand, are primarily winter storms which originate in the middle latitudes and move from the ocean shoreward. Occurring more frequently than the tropical storms, the "northeasters" produce a relatively uniform surge over wide areas due to an extensive low pressure field in addition to wind stress effects. Both types of storms produce flood elevations which are combinations of three basic elements: (1) the astronomical tide, (2) the surge associated with the storms, and (3) wave set-up superimposed on the raised water level.

The astronomical tide throughout Chesapeake Bay is predominantly semidiurnal with two high waters and two low waters per lunar day of 24.84 solar hours. There is a tendency toward mixed diurnal-semidiurnal conditions in the upper half of the Bay which is manifested by an inequality in successive low water heights in the vicinity of the Choptank River and an inequality in successive high water heights in the upper quarter of the Bay (Hicks, 1964). The mean tidal range progressively decreases from 3.0 feet at the entrance to a minimum of 0.9 feet at Annapolis, Maryland, increasing thereafter to about 2.0 feet at the head of the Bay. Due to the Coriolis effect, tidal ranges tend to be larger along the Eastern as opposed to the Western Shore at a given latitude, particularly in the wider lower half of the Bay.

Tidal gaging information in the Bay area has been collected for a number of years at various locations. Unfortunately, only a few areas have had continuous gaging such that reasonably good estimates of flood levels are available: Norfolk, Kiptopeke, Annapolis, Baltimore, and Washington for example. For the most part, there are insufficient

historical records on a Bay-wide basis for accurate flood-level frequency assessment. Also the fact that storm surges within the Bay can vary greatly over a short distance, seriously limits the interpolation or extension of the data between those few stations where reliable tide data exist. Therefore, the need for synthetic data through hydraulic and/or numerical modeling techniques has increasingly become a necessity for the Chesapeake Bay Region.

The storm surge problem for any bay system has been approached through several hydrodynamic methods by many investigators. All past studies concerned only the nearshore and offshore regions of the ocean or only the bay and did not consider a bay-ocean system because previous models weren't compatible with complex coastal configuration and shallow water. Analytical solutions to some simple storm surge problems have been developed by several investigators, such as Lamb (1945), Bretschneider (1966), and Dean and Pearce (1972) but have limited application due to the complexities of actual driving forces, coastal configuration, and topography. A more realistic approach to storm surge problems using numerical techniques was originally proposed by Hansen (1956). Since then many investigators have developed various finite difference numerical schemes for two-dimensional storm surge calculations, such as Platzman (1958), Hansen (1962), Reid and Bodine (1968), Jelesnianski (1965, 1966, 1967, 1970, 1974), Pearce (1972) and Butler (1978).

The most advanced stage-frequency information for Chesapeake Bay are the surge predictions developed by the Virginia Institute of Marine Sciences (VIMS) as part of a study for the Federal Insurance Administration. This study determined tidal elevations at 21 selected stations on or near the shore of Chesapeake Bay for frequencies of 10, 50, 100, and 500 years. The hydrodynamic model used was developed by H.S. Chen and is basically a two dimensional depth-integrated numerical model of a bay-ocean system. Although the tributaries of the Bay were excluded from examination in this model, the use of a finite element scheme was employed to more efficiently represent the coastal configuration of Chesapeake Bay. Results obtained from this model were adopted by the Federal Emergency Management Agency (FEMA) for use in the determination of flood insurance rates and the preparation of flood hazard mapping in the Bay Region.

The hydrologic analyses conducted during the Tidal Flooding Study were based on actual tidal data or the previously mentioned VIMS Study. Actual tidal records were used if sufficient data existed to conduct a conventional statistical analysis. This procedure was followed for the communities of Norfolk and Kiptopeke, Virginia. For the communities of Rock Hall and St. Michaels, Maryland, specific tidal data weren't available. Therefore, the stage-frequency relationships established for the VIMS data station nearest the community were assumed to represent the actual stage-frequency relationship for that community. For those communities where both historical gage data stations and VIMS data stations were equidistant - Tangier Island and West Point, Virginia, - both frequency relationships are presented and two sets of damage calculations are carried through the report.

It should be noted that due to the nature and extension of some of the data, a sensitivity analysis was conducted which reflected both a 1-foot shift in stage and the use of differing sets of frequency curves. It should also be noted that as part of a continuing study effort, a hydraulic/numerical modeling effort is needed to develop stage-frequency

relationships in all identified critical flood-prone communities as well as along all of the Bay's major tributaries.

Figures E-1 through E-14 represent the stage-frequency relationships used for each of the communities examined. For the communities analyzed with the VIMS information, curves were drawn from data provided for the 0.1, 0.2, 0.01, and 0.02 recurrence probabilities (in heights above the National Geodetic Vertical Datum of 1929). For the communities analyzed with historical gage information, the stage-frequency curves were drawn from data provided for the 0.8 to 0.01 probabilities of recurrence (in heights above mean sea level). Wave height analyses have also been made for the Federal Emergency Management Agency at Cape Charles, Poquoson, and Tangier. In Hampton Roads, studies have been made at Hampton, Newport News, Norfolk, Portsmouth, and Virginia Beach. The maximum wave height varied from 2.2 to 4.5 feet above the stillwater elevation of the 100-year flood (0.01 probability of recurrence). The results of these examinations and their impacts upon average annual damages are found in Appendix B - Plan Formulation, Assessment, and Evaluation.

ENGINEERING DESIGN

STRUCTURAL MEASURES

FLOODWALLS

The floodwalls considered were of the inverted "T" type and were based on design criteria contained in Engineering Manual 1110-2-2501 - Wall Design: Flood Walls. The walls would be constructed of reinforced concrete with three feet of freeboard above the design heights. The design heights were generally selected to protect against the 100-year and 500-year flood event based on recurrence intervals determined for each community. Since the topography of each community varies as does the predicted flood height, floodwalls with heights ranging from two feet to ten feet above ground were examined. A section of a typical flood wall is presented in Figure E-15.

FLOOD LEVEES

Constructed of impervious material, the earth levees would have 10-foot widths and side slopes of one vertical on three horizontal. An inspection trench would be excavated under all levees to a depth of nine feet. This trench would have a bottom width of 10 feet with side slopes of one vertical on one horizontal. Armoring, through the use of riprap, would be provided on the water side of the levees. The tops of the levees would be set at the design water surface elevation plus three feet of freeboard. The same design heights were investigated for levees and structural plans with floodwall and levee combinations. Figure E-16 presents a section view of a typical levee. With the construction of any floodwall or levee, additional features and considerations would be required to include providing for access to wharves and piers, dewatering measures, closure structures for other than major roadways, and interior drainage facilities. However, these features weren't included in the development of plans and costs were developed only in cases where cost-benefit analyses indicated more detailed study was warranted.

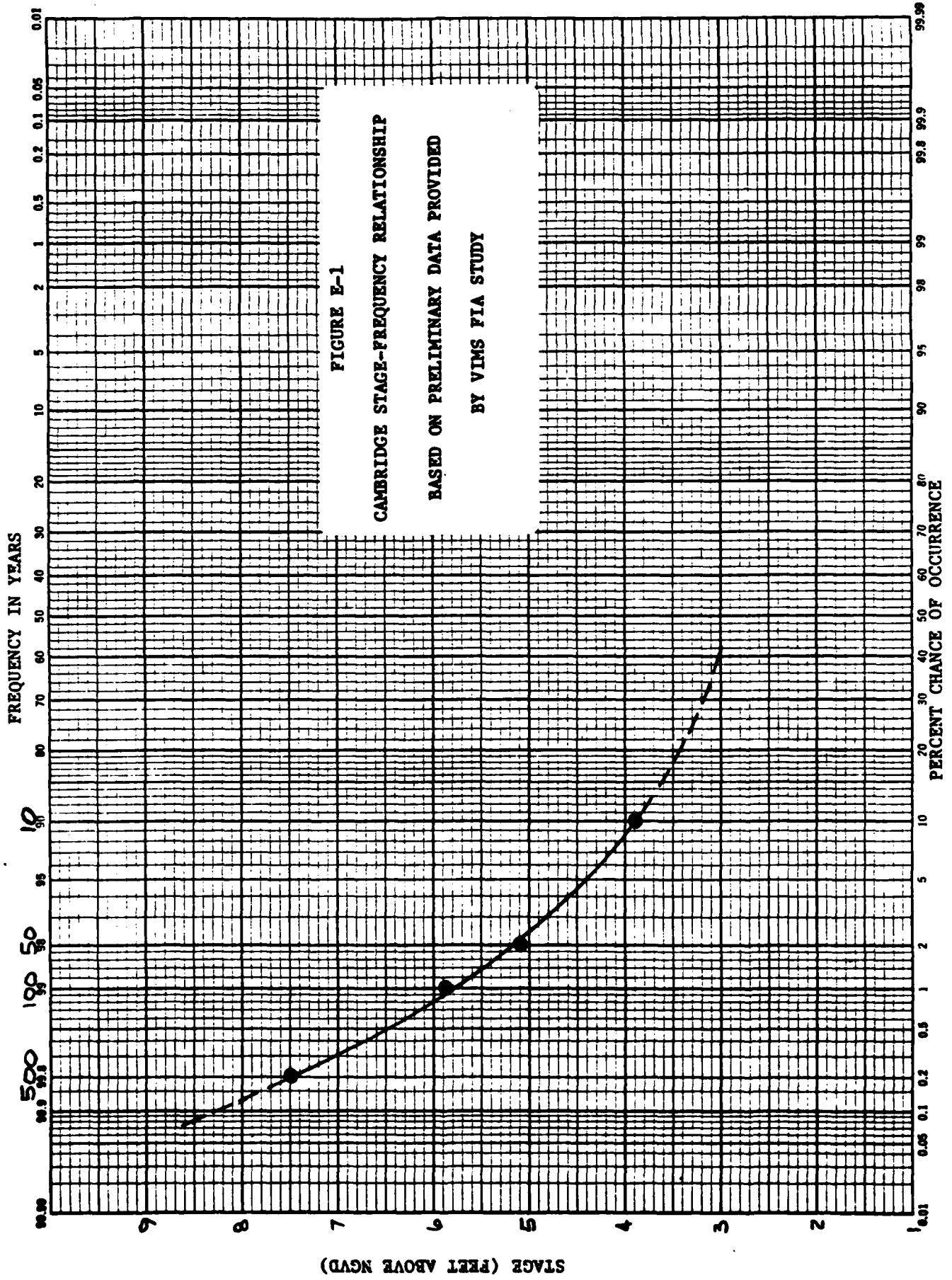

FREQUENCY IN YEARS

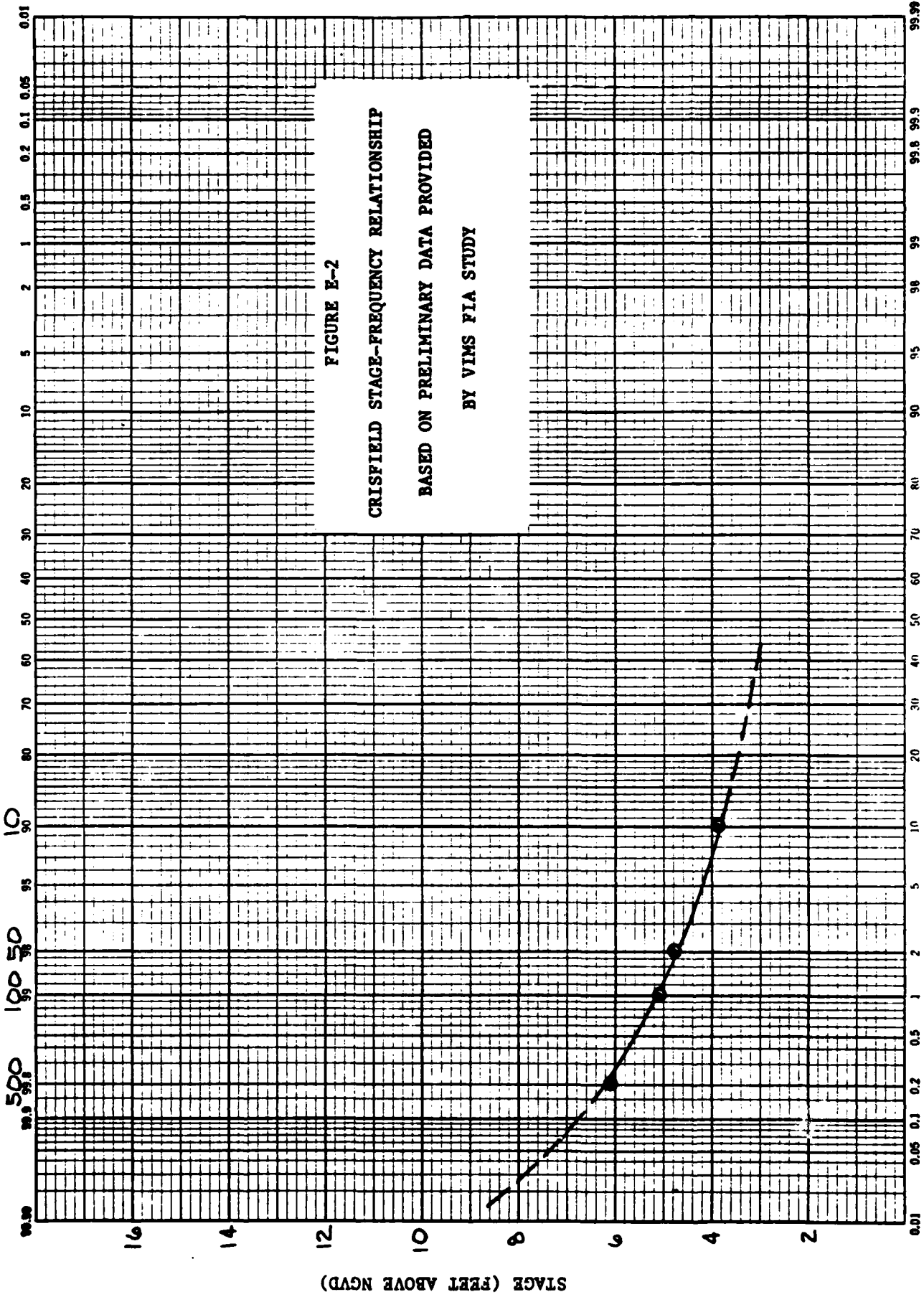

STAGE (FEET ABOVE NGVD)

E-5

FIGURE E-2
CRISFIELD STAGE-FREQUENCY RELATIONSHIP
BASED ON PRELIMINARY DATA PROVIDED
BY VIMS FIA STUDY

PERCENT CHANCE OF OCCURRENCE

0.01 0.05 0.1 0.2 0.5 1 2 5 10 20 30 40 50 60 70 80 90 95 96 99 99.5 99.9

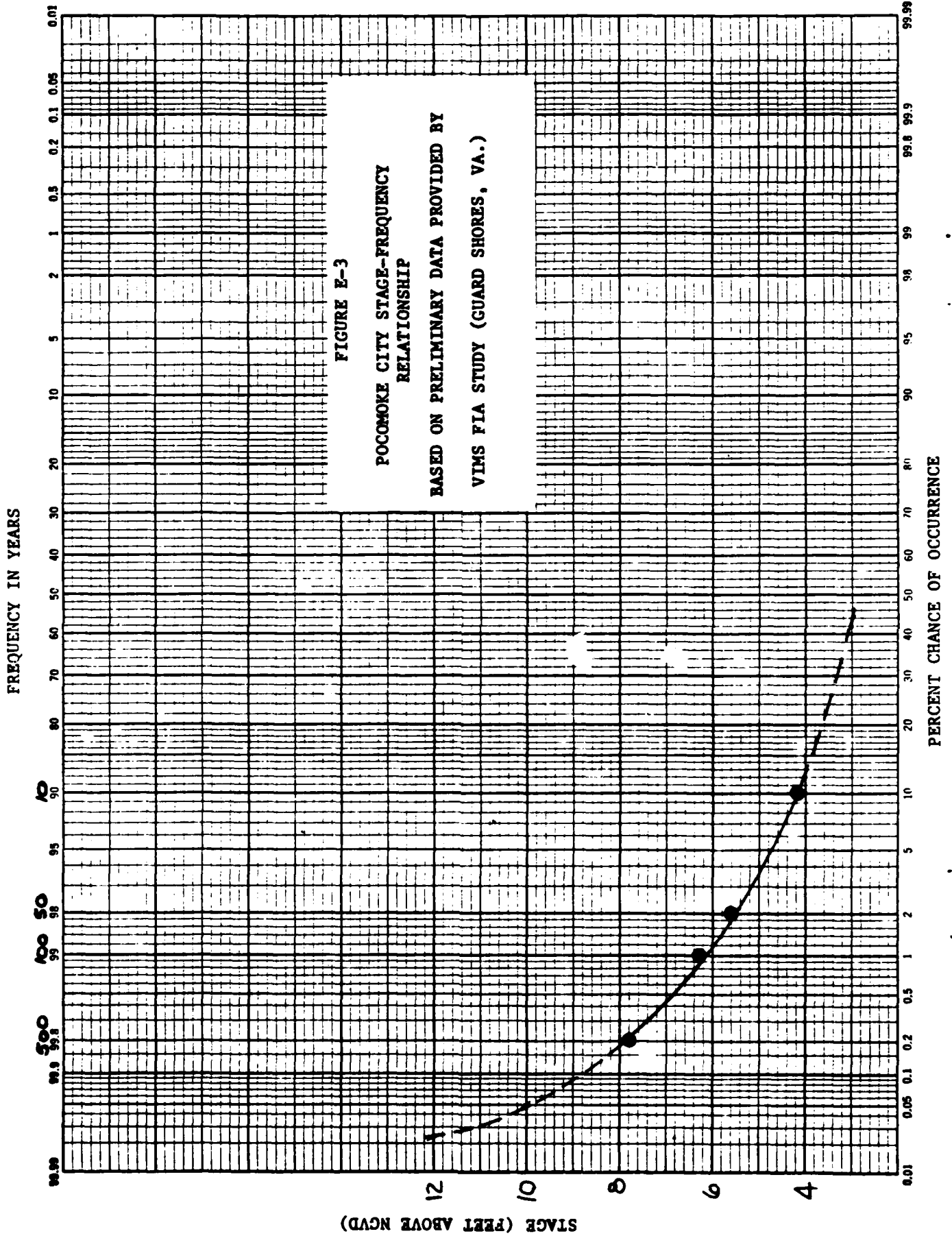

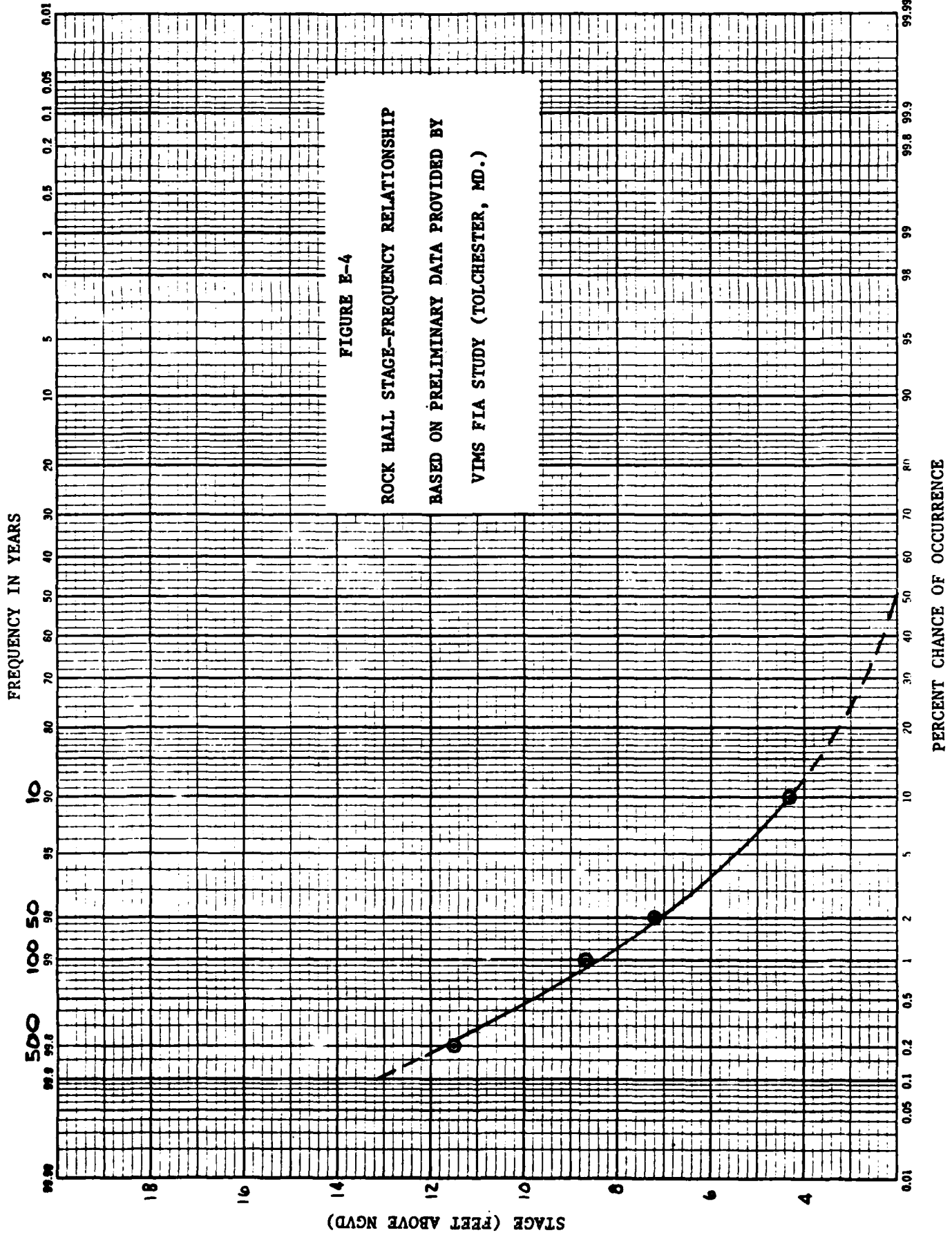
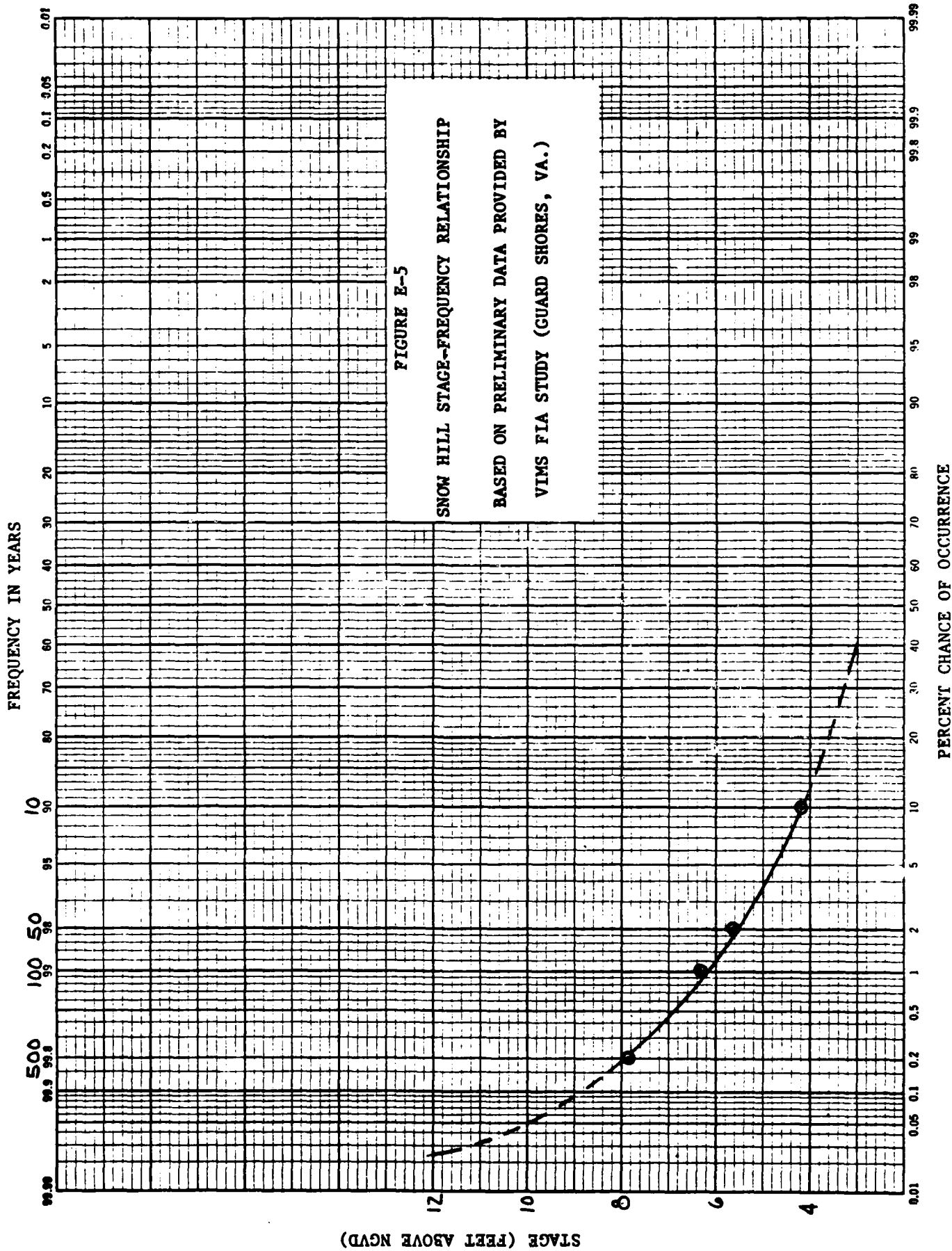
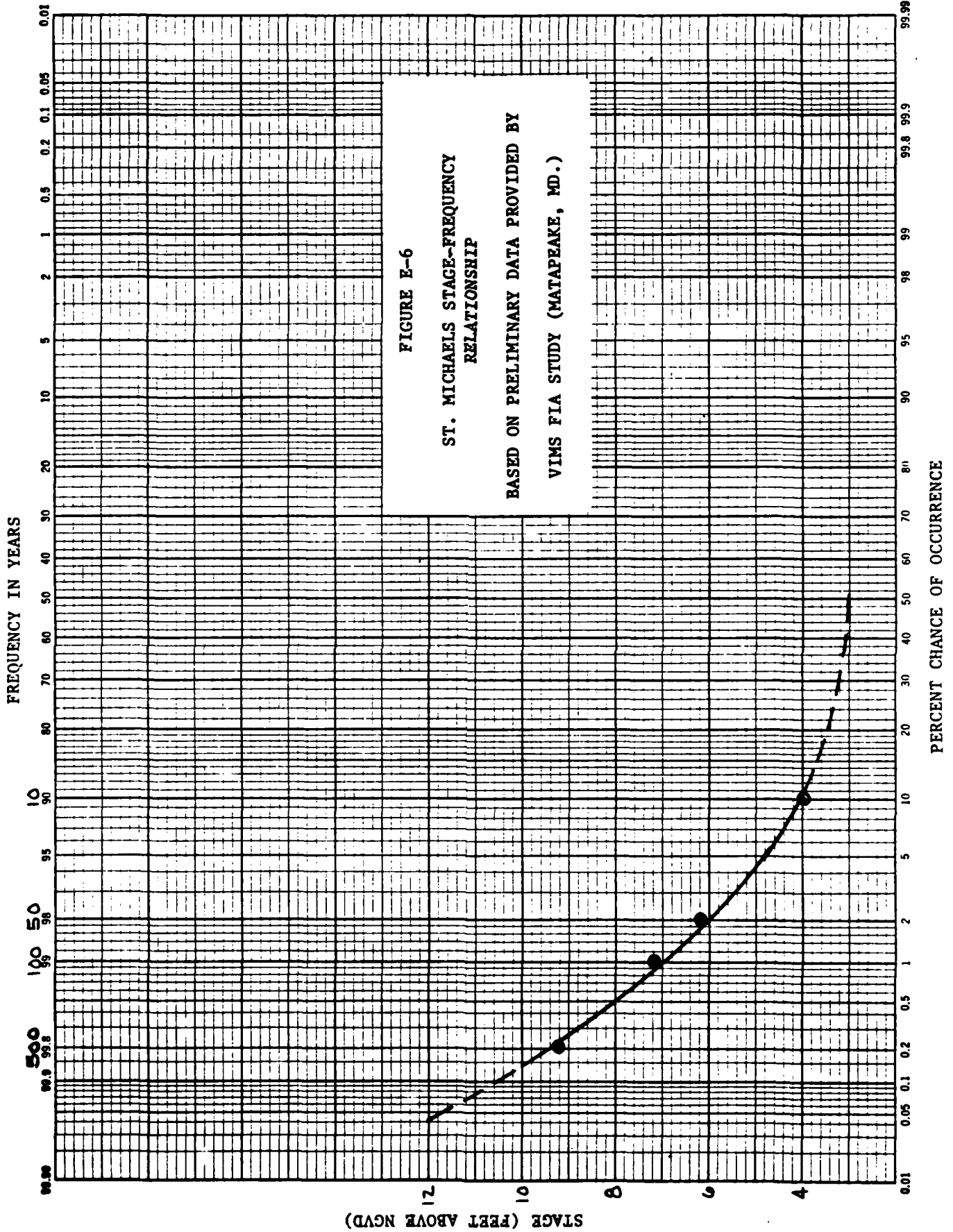

FIGURE E-4
ROCK HALL STAGE-FREQUENCY RELATIONSHIP
BASED ON PRELIMINARY DATA PROVIDED BY
VIMS FIA STUDY (TOLCHESTER, MD.)





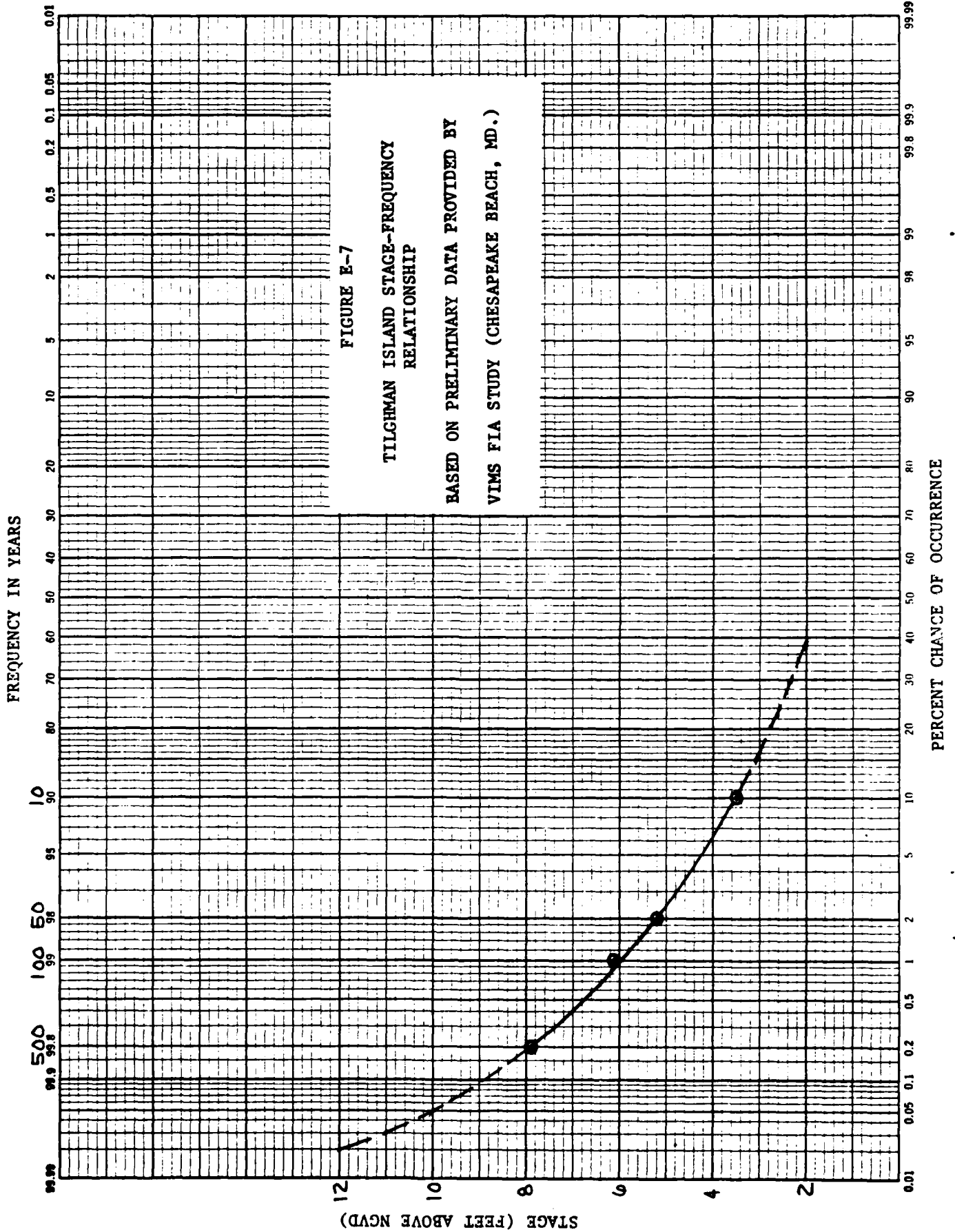
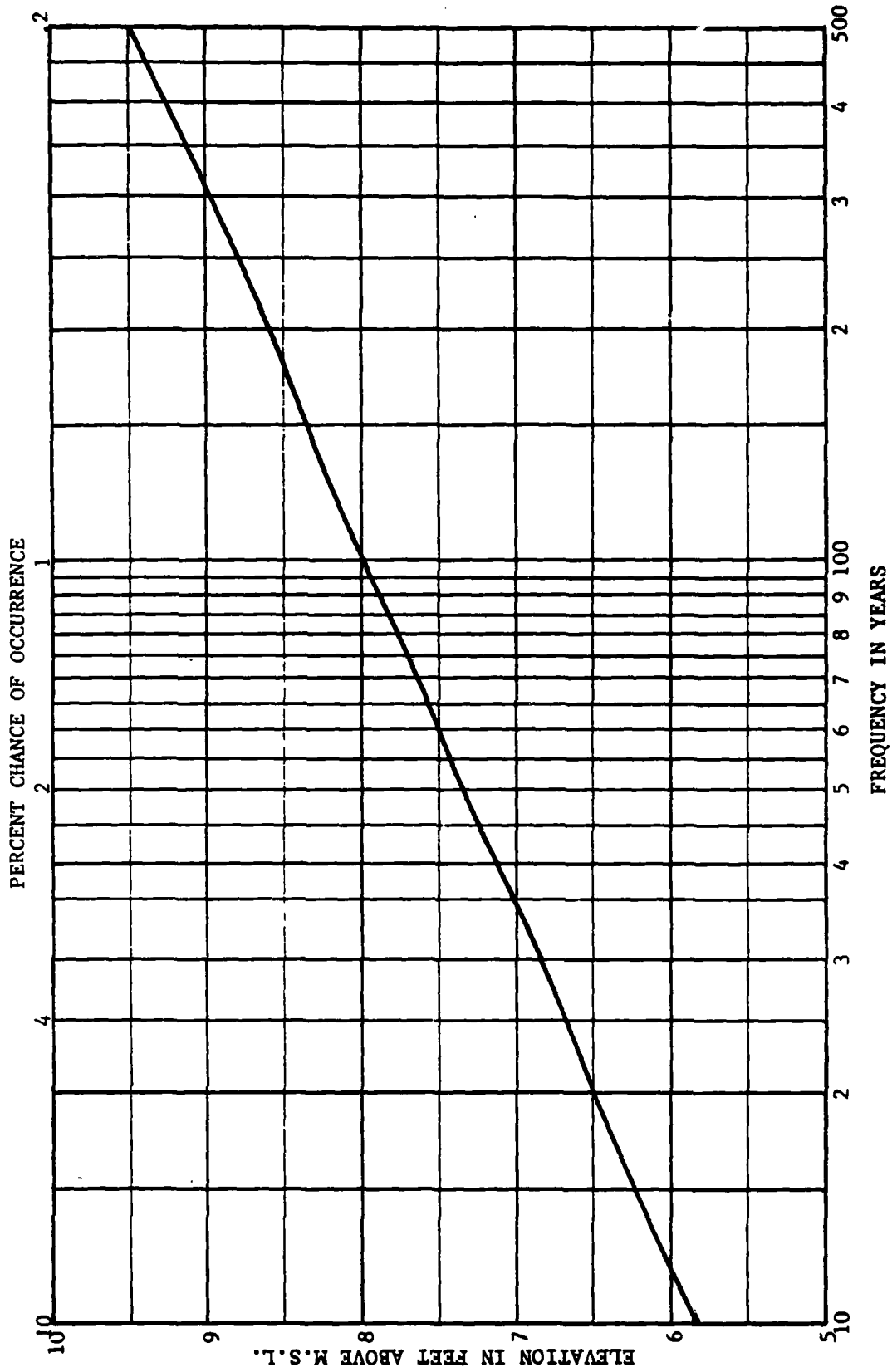

FIGURE E-8

CAPE CHARLES STAGE-FREQUENCY RELATIONSHIP



From FLOOD INSURANCE STUDY,
CAPE CHARLES, VA. 2 August, 1982
by Federal Emergency Management Agency.

FIGURE E-9
 HAMPTON ROADS STAGE-FREQUENCY RELATIONSHIP

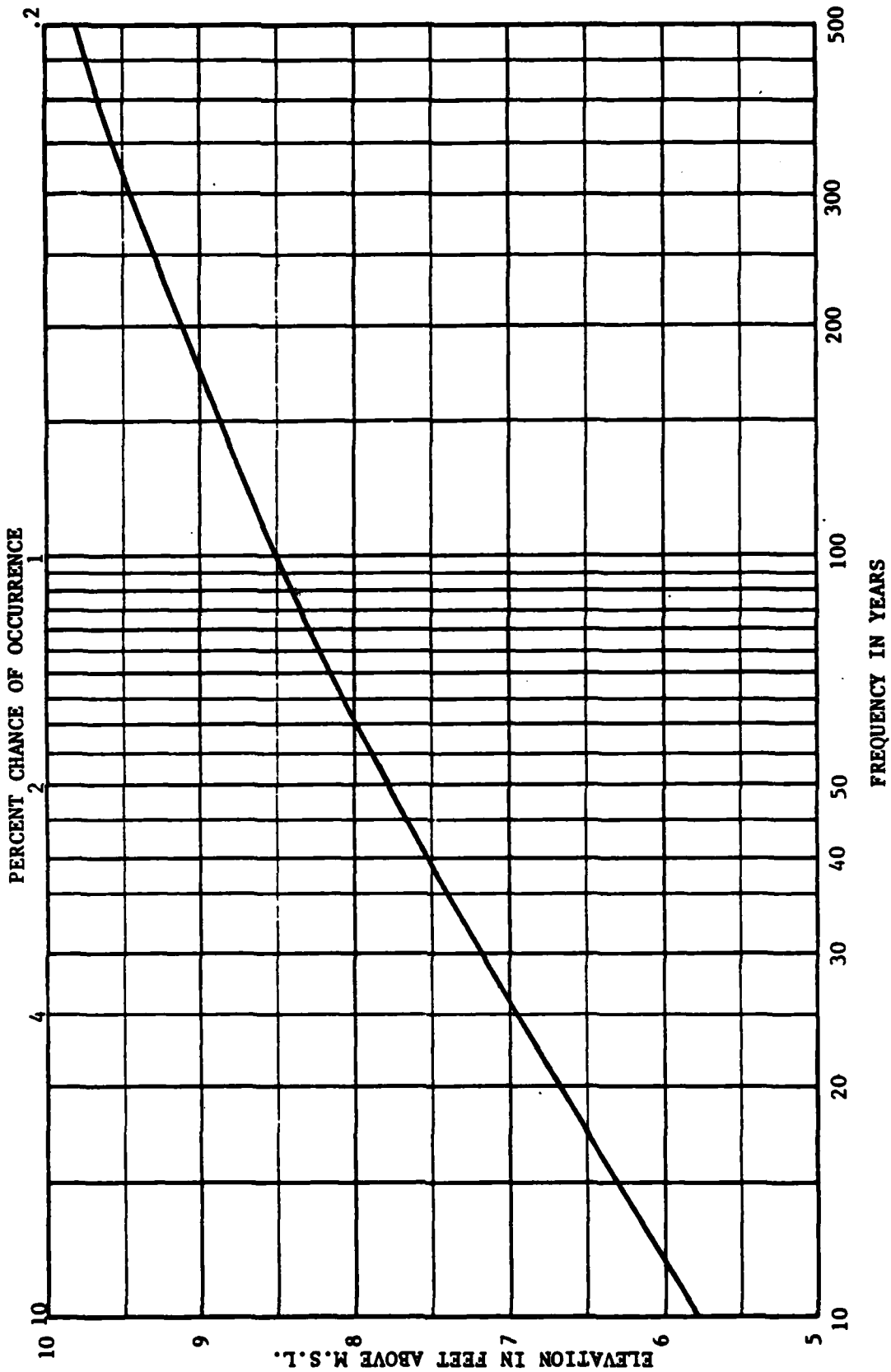

From FLOOD INSURANCE STUDY, HAMPTON, VA., August 1970
 by Federal Insurance Administration.

FIGURE E-10

POQUOSON STAGE-FREQUENCY RELATIONSHIP

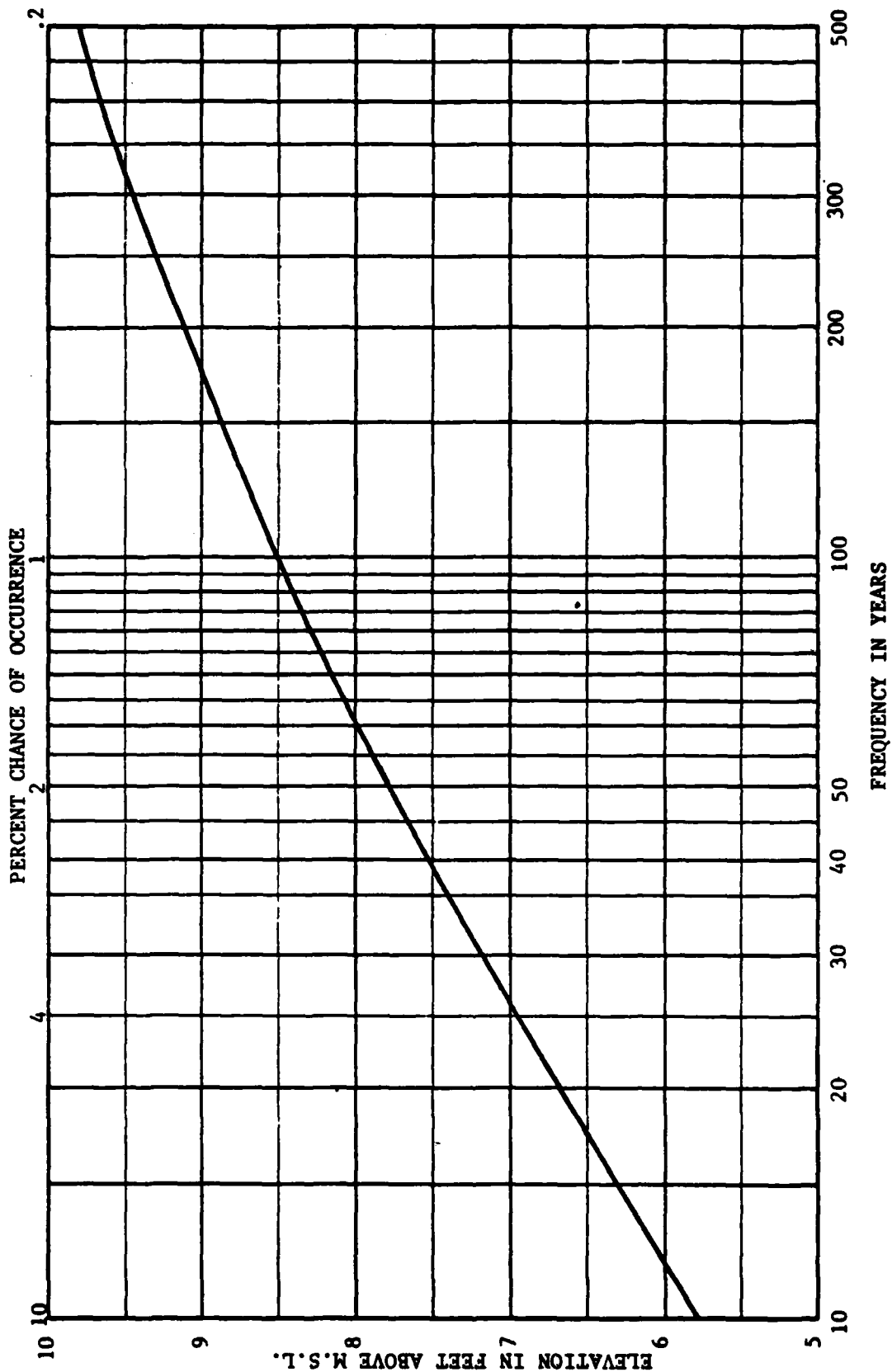

From FLOOD INSURANCE STUDY, POQUOSON, VA.,
November, 1976 by U.S. Department of Housing
and Urban Development, Federal Insurance
Administration.

FIGURE E-11

TANGLIER ISLAND STAGE-FREQUENCY RELATIONSHIP - CORPS

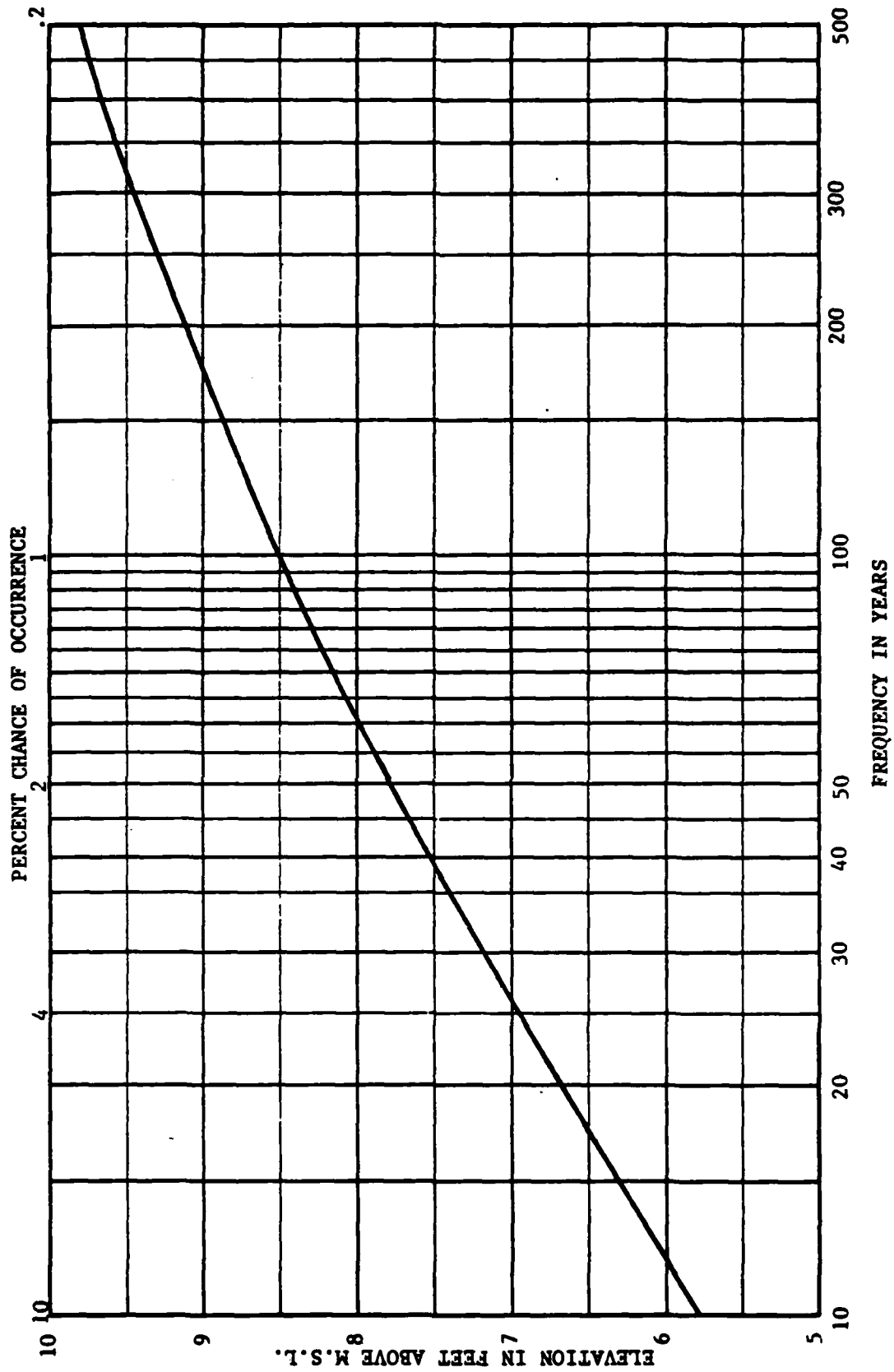

From FLOOD INSURANCE STUDY, POQUOSON, VA.,
November, 1976 by U.S. Department of Housing
and Urban Development, Federal Insurance
Administration.

FIGURE E-12

TANGIER ISLAND STAGE-FREQUENCY RELATIONSHIP - VIMS

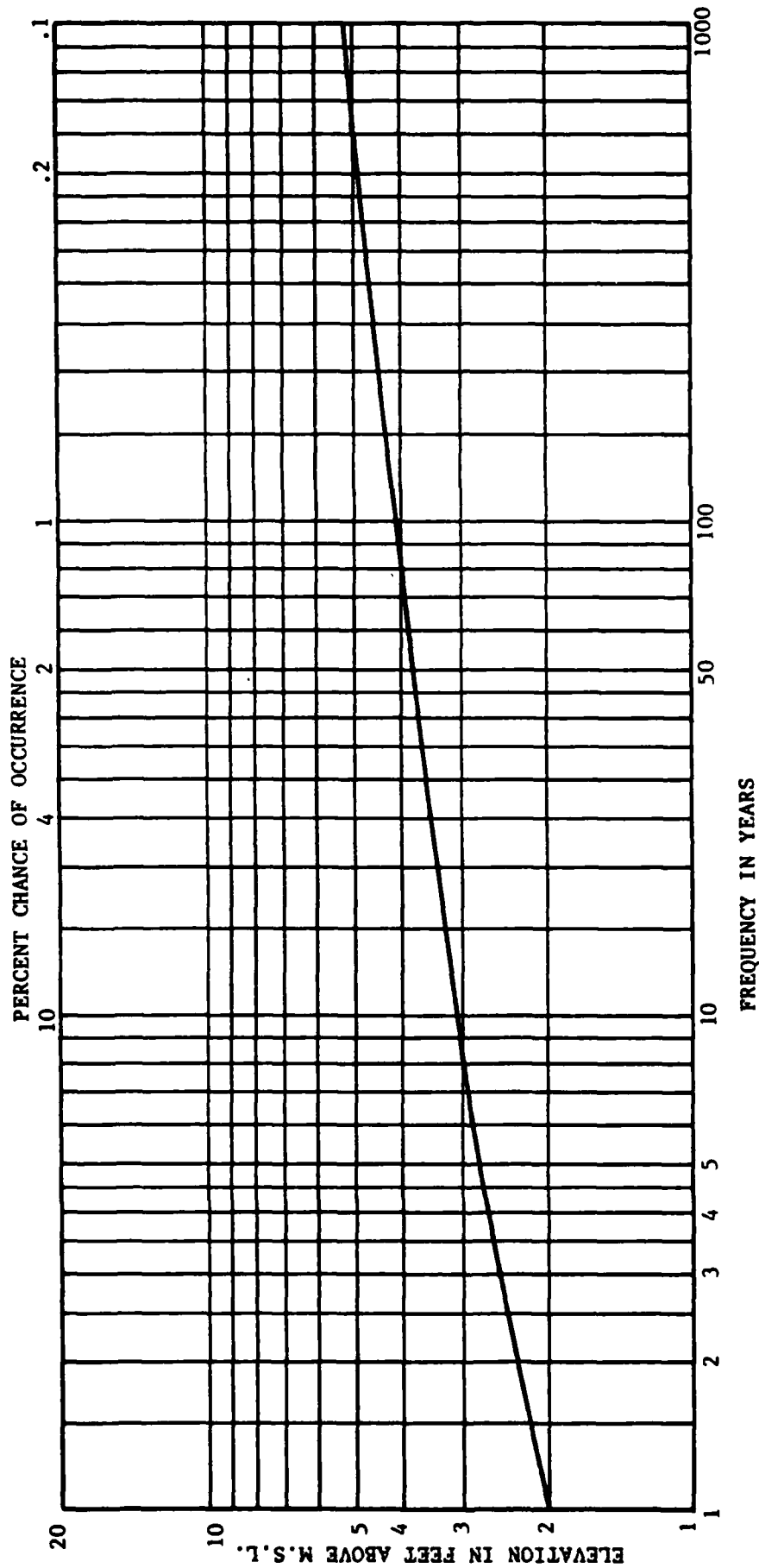

From FLOOD INSURANCE STUDY, TANGIER, VA. 15 April, 1982
by Federal Emergency Management Agency.

FIGURE E-13

WEST POINT STAGE-FREQUENCY RELATIONSHIP - CORPS

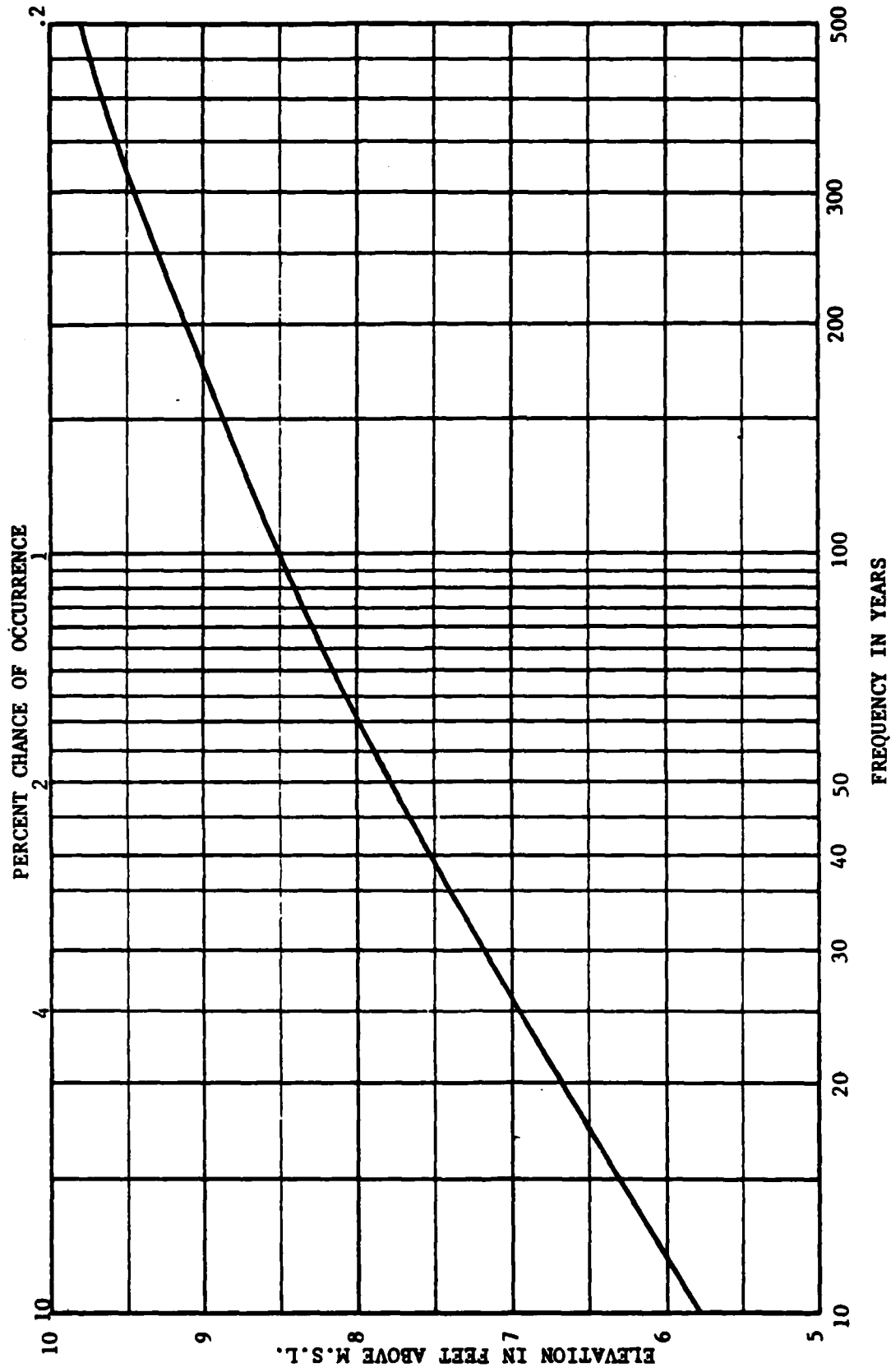

From FLOOD INSURANCE STUDY, POQUOSON, VA.,
November, 1976 by U.S. Department of Housing
and Urban Development, Federal Insurance
Administration.

FIGURE E-14
 WEST POINT STAGE-FREQUENCY RELATIONSHIP - VIMS

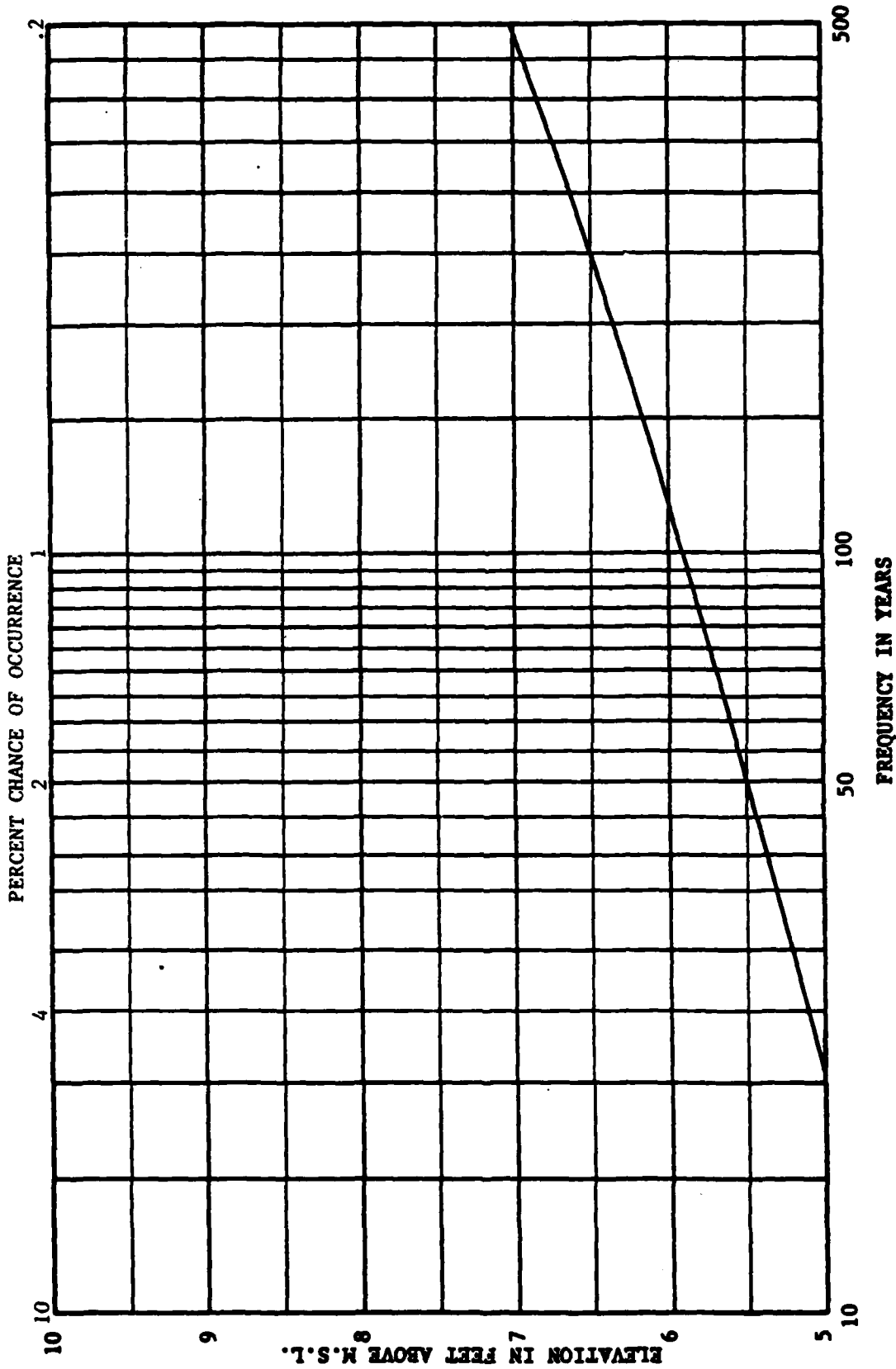

Based on figure 8.2 (Gloucester Point) in
 Special Report 189, June 1978 "Frequency Analyses
 and Model Prediction for Chesapeake Bay", by V.I.M.S.

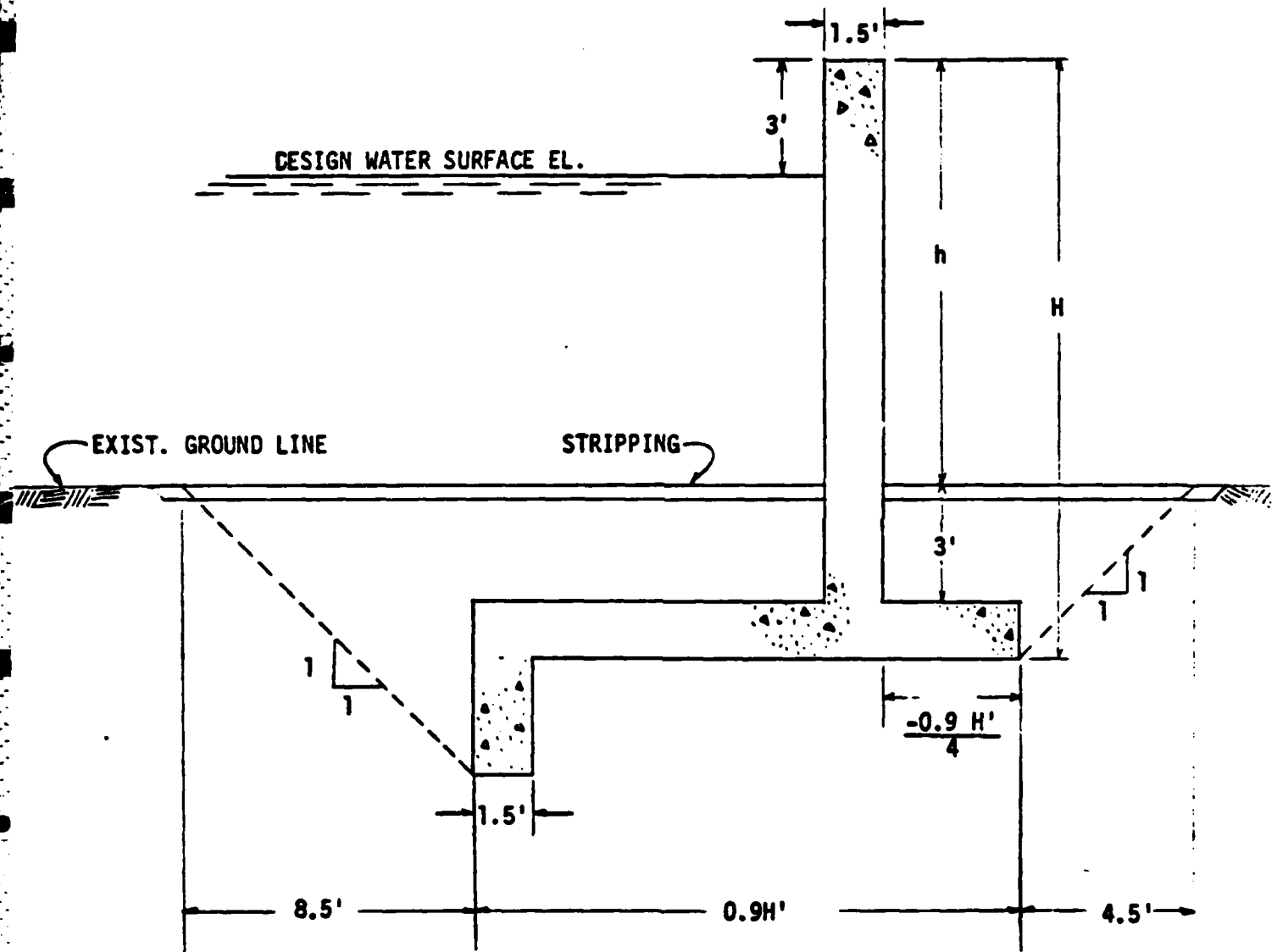
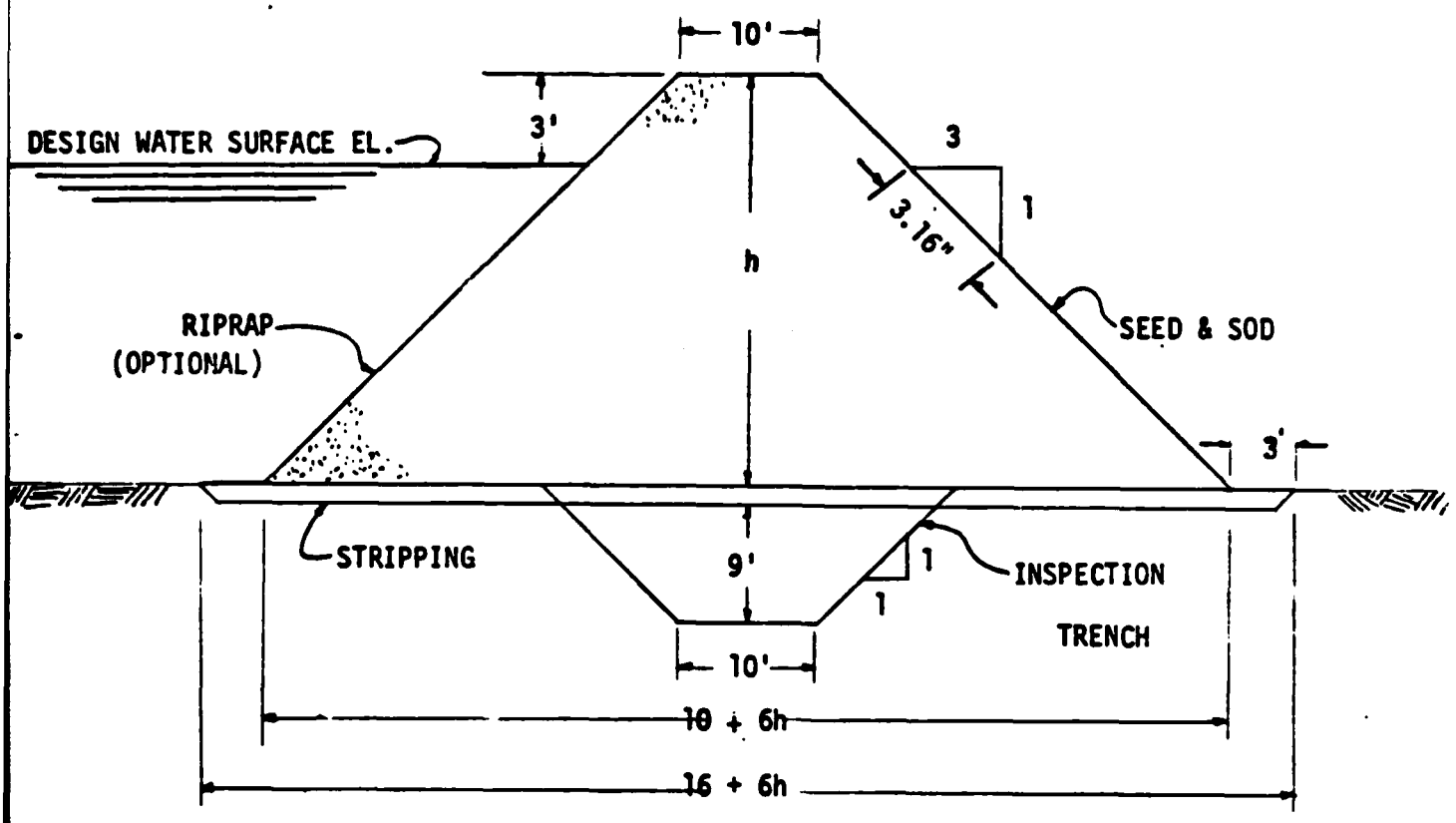

FIGURE E-15 TYPICAL WALL SECTION



NOT TO SCALE

FIGURE E-16 TYPICAL LEVEE SECTION

STEEL SHEET PILE BULKHEAD

During the investigation, it was determined that the cost per linear foot for concrete floodwalls was similar to that for steel sheet pile bulkhead. It was then assumed that the results of any evaluations for floodwalls would also apply to steel sheetpiling. Therefore, a separate detailed evaluation wasn't conducted for steel sheet pile bulkhead.

NONSTRUCTURAL MEASURES

The guidelines used for consideration of nonstructural measures were based on an update of information developed as part of the Baltimore District's Susquehanna River Basin Flood Control Review Study. This information was published in Institute for Water Resources (IWR) Pamphlet No. 4, Cost Report on Non-Structural Flood Damage Reduction Measures for Residential Buildings Within the Baltimore District, July 1977. The degree of tidal flood protection investigated varied from community to community but was based on the recurrence level associated with even-foot increments of flooding from the point of zero damage to the approximate level of the one hundred year flood. A combination of the most appropriate measures to protect all structures in a community at a particular depth of flooding was referred to as a "plan." Further, a nonstructural plan wasn't developed for any depth of community flooding unless a minimum of 20 structures received flood damages. Selection of the appropriate nonstructural measure for any structure was based on factors to include the age of the structure, the type of construction, the depth of flooding, and cost effectiveness. The nonstructural measures considered are presented in the following paragraphs.

RAISING OF STRUCTURE

Raising of the first floor was considered for both residential and commercial structures in good condition with a first floor area less than 1,500 square feet. The heights to which structures were to be raised were selected to keep flood waters below the first floor and to permit an even number of courses of eight-inch concrete block to be used (e.g. heights of 1' 4", 2' 8", 3' 4", 4' 0", and 5' 4"). For each height increment it was assumed that nothing would be done to prevent basement flooding. However, if necessary, the construction of a utility room to accommodate utilities and mechanical equipment was considered. Only the main structures were considered for raising; storage sheds and other outbuildings were considered to remain at their existing elevation. The following assumptions were made in the evaluation of this alternative:

1. Houses with concrete block foundations could adequately support the additional layers of block required for the raisings,
2. Houses with stone, brick, or combination stone-concrete foundations were considered incapable of supporting the additional layers of block required for the raisings,
3. New footings would have a 28-day compressive strength of 2,500 pounds per square inch,
4. Houses would be raised by using steel beams and jacks, and
5. Estimates of costs would include the house raising, the removal of the existing foundation, new foundation work, and landscaping.

The success of this alternative would be contingent upon the structural soundness of the existing foundations and the buildings themselves. This determination, however, would require a detailed structural analysis of each building. Costs reflective of this analysis, therefore, were not included. Figure E-17 shows typical house raisings for two different elevations with respect to the structure and existing ground conditions.

UTILITY ROOM ADDITION

Construction of a wood-frame utility room adjacent to the structure at the first floor level was considered for homes receiving basement flooding only and for those few homes with basements that had their first floors raised above design flood levels. Estimates of the costs included all excavation and foundation work, construction of the superstructure itself, all electrical work, relocation of equipment, and provision of a check valve in the sanitary lines. Figure E-18 illustrates a typical addition of a utility room to the main structure.

RELOCATION OF STRUCTURE

Relocation of a residential structure to a new site beyond the limits of the flood plain was considered for homes and trailers in good condition which are subject to frequent and substantial (depths of two feet or more) flooding. This alternative entailed disconnecting and capping all utilities at the present site, removal of obstructions enroute to the new location, construction of a new foundation at the relocation site, razing or backfilling at the abandoned site, connection of utilities at the new site, and any grading and landscaping necessary at the new site. The cost for these items was based on the following assumptions:

1. The house or trailer could be relocated within a 10-mile radius,
2. A new housing site was available along an existing public road with utility services, and
3. The existing electrical and mechanical fixtures in the structure to be relocated complied with local building codes.

For the purpose of this report, the additional costs associated with relocations were assumed to include only the purchase of the land at both the old and new sites. No costs were included for purchase of the home or resettlement expenses as implied by the Uniform Relocation Assistance and Real Property Acquisition Policies Act of 1970, Public Law 91-646, Section 302(a). If the purchase of a property owner's house and other improvements located on the land became mandatory, then the costs to move the house would be incurred by the property owner. The property owner would then be eligible for resettlement benefits which would have to be included in the assessment.

ACQUISITION AND DEMOLITION

This measure was considered for both commercial and residential structures less than 3,000 square feet in area, in poor condition, and subject to frequent and substantial (depths of two feet or more) flooding. Included in the cost assessments were: 1) the cost of purchasing a particular structure and relevant land area at a fair and reasonable price; 2) the costs associated with demolition of the structure; 3) site restoration costs

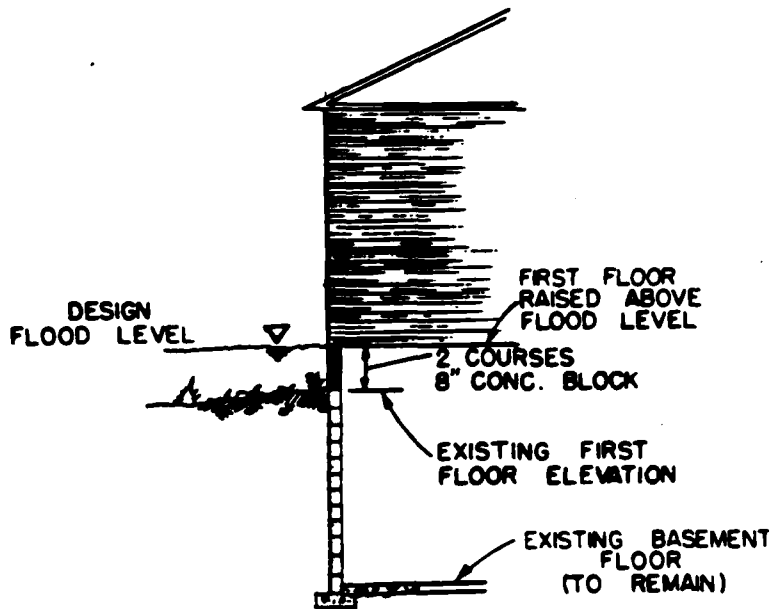

RAISING FIRST FLOOR 1'-4"

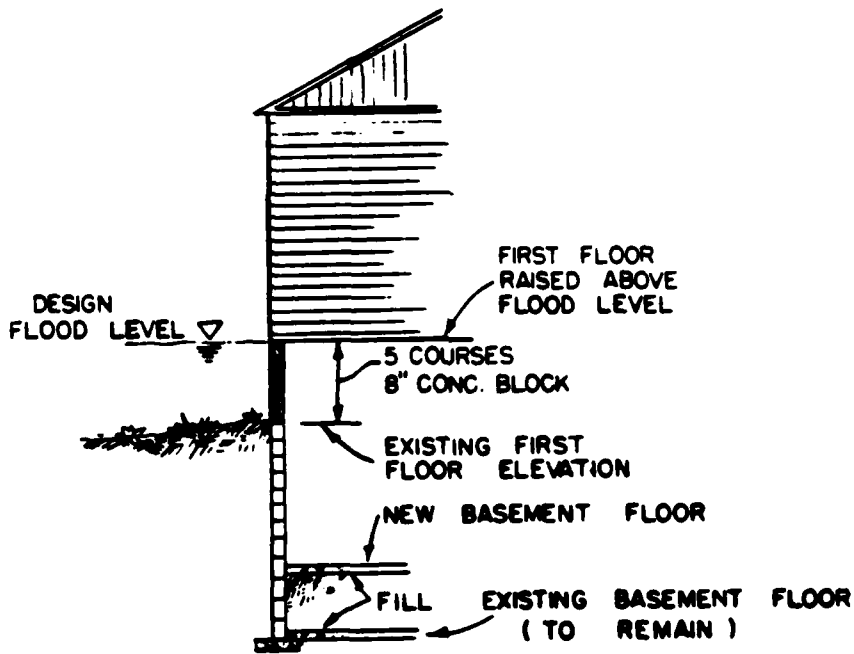

RAISING FIRST FLOOR 3'-4"

FIGURE E-17 FIRST FLOOR RAISING

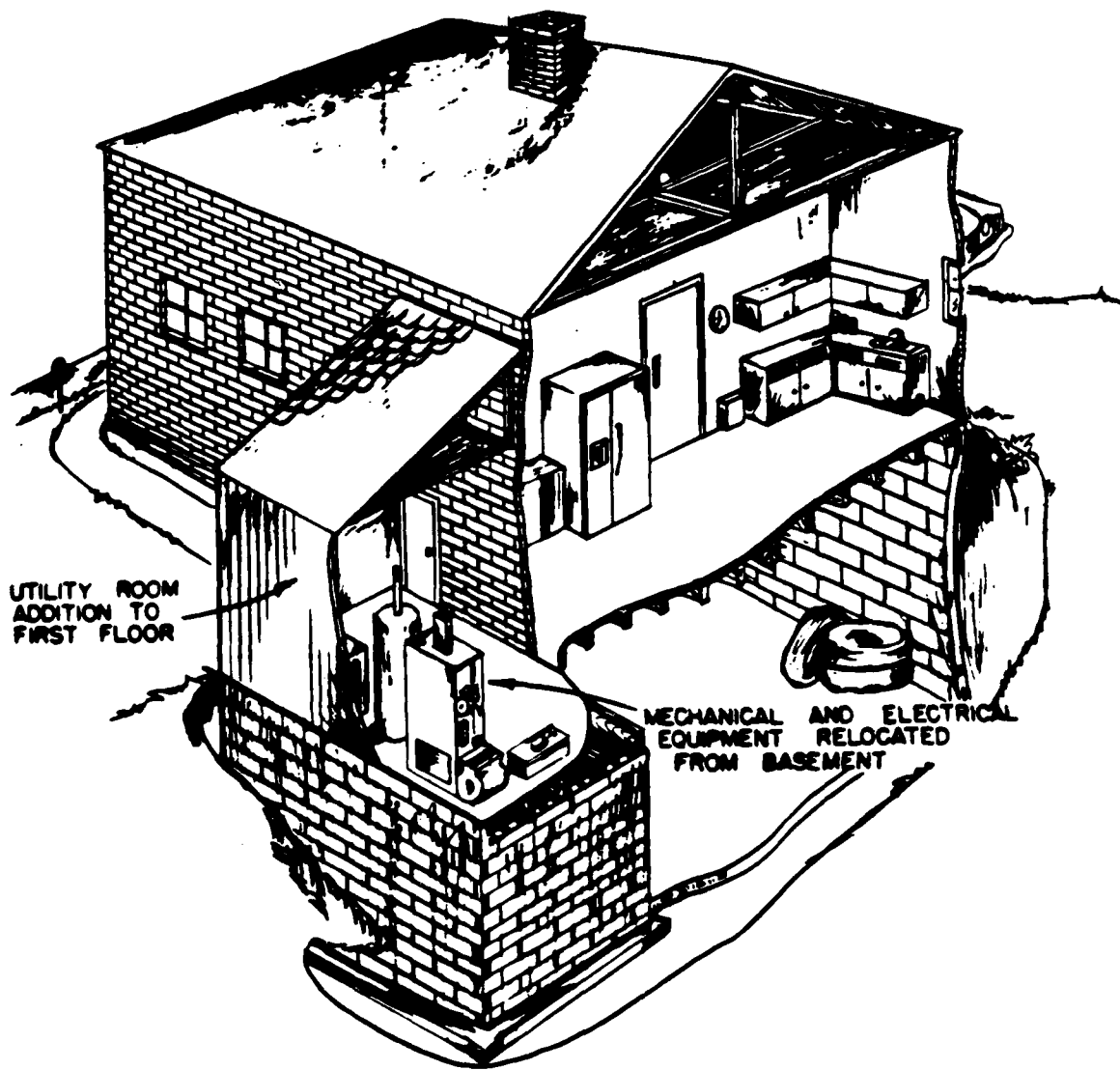

FIGURE E-18 UTILITY ROOM ADDITION

incurred by filling, grading, and seeding; and 4) relocation and resettlement expenses for the owner. Site restoration did not include the razing of public streets or sidewalks. It should be noted that the cost assessment included an allowance for acquisition costs in conformance with the requirements of PL 91-646.

FLOODPROOFING

Flood Shields

Floodproofing of existing structures was considered for only those commercial buildings constructed of block or brick and in good structural condition. The guidelines used were based upon the requirements of Engineering Pamphlet 1165-2-314, Flood-Proofing Regulations, June 1972, together with information concerning large flood shields developed during the Susquehanna River Basin Flood Control Review Study. In the evaluation of this alternative, the following assumptions were made:

- 1) Floodproofing was not applicable to metal or wood-frame structures,
- 2) All buildings would be floodproofed to an elevation one foot above the design flood with an upper limit of six feet above the first floor,
- 3) All windows and doors with a majority of the opening (75 percent or more) below the design flood stage would be closed permanently by brick,
- 4) Small windows and doors with openings above the design flood stage would be protected by installation of 1/4-inch thick aluminum flood shields,
- 5) Openings of 10 feet or more horizontally would receive large flood shields with vertical supports on 10 foot centers,
- 6) Costs for large flood shields, whether for placement in windows or doors, were the same, and
- 7) Aesthetics were not considered.

Estimates of costs would include the cost of flood shields and related appurtenances, costs for permanent closure of inundated openings by brick, costs of waterproofing the existing structure with a polyethylene coating, and costs of installing an adequate number of sump pumps and backflow valves in utility lines. Costs associated with storage and installation of the flood shields were not included in the estimate. Depending upon the size and number of flood shields required, this cost could merit additional consideration. Figure E-19 presents an installation and storage scheme for large flood shields. The success of this alternative would be contingent upon the structural soundness of the buildings and the assumptions made regarding the size and number of openings in each structure.

Floodwalls

The use of small floodwalls for floodproofing was considered for those types of commercial buildings for which no other nonstructural measure was found economically or structurally feasible. Floodwalls were selected rather than levees because of the tight space requirements encountered in most of the communities. Figure E-20 shows the placement of a typical gravity floodwall with respect to its location to the structure.

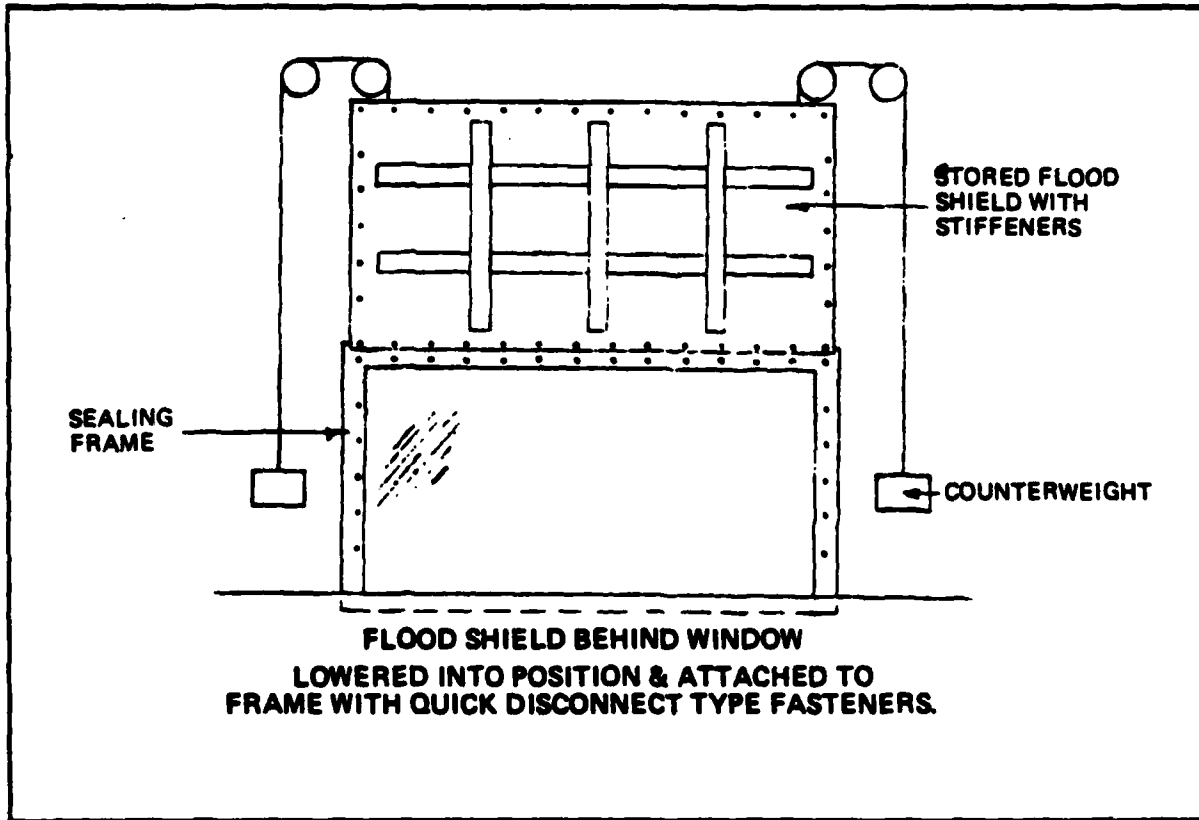

FIGURE E-19 FLOOD SHIELD INSTALLATION AND STORAGE SCHEME

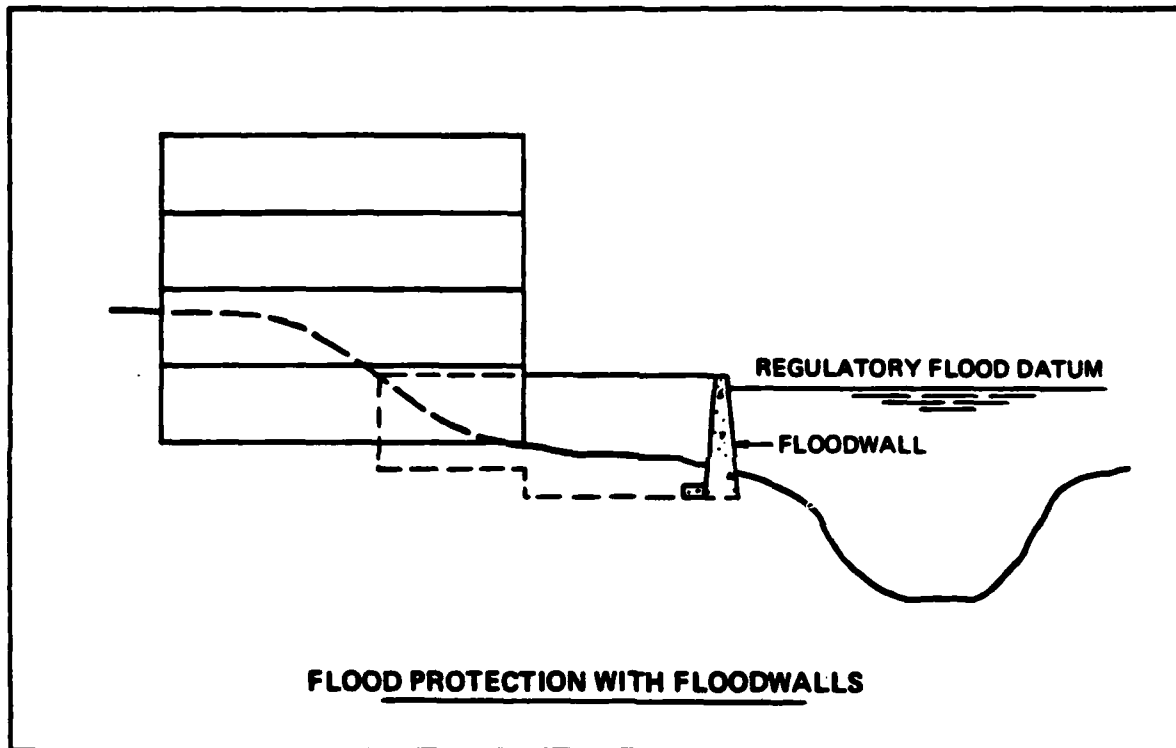

FIGURE E-20 GRAVITY FLOODWALL

The floodwalls themselves were of the standard gravity-type based on design criteria contained in EM 1110-2-2501. The walls would be constructed of reinforced concrete and would be designed to include between one and two feet of freeboard, depending on the proximity of the wall to the waterfront. Design heights were selected to protect against occurrences as low as the 15-year event and as high as the 100-year event. The corresponding wall heights investigated, accounting for changing topography, varied from two feet to eight feet above the original ground line. Figure E-21 provides an illustration of a typical wall section.

Provisions for access to buildings, wharves, or piers, dewatering measures, closure structures of all types, and interior drainage facilities would have to be made with construction of these walls. However, these features weren't included in the evaluation of this measure. Due to the sandy composition and questionable foundation conditions in all of the communities, detailed subsurface investigations would be required to determine the necessity and extent of using piles.

FLOOD CONTROL PLAN COST ESTIMATES

As a result of the preliminary tidal flooding analyses conducted in 1979 and 1980, 12 communities within the Chesapeake Bay Region were identified as having potential need for a Federally-sponsored tidal flood control project. These communities are listed in Table E-1. Because of the areal expanse of the Bay Region, and because of the jurisdictional location of these communities, the Baltimore District, Corps of Engineers requested that the Norfolk District conduct the assessment of the tidal flooding problems in the Commonwealth of Virginia while the Baltimore District investigated the Maryland communities.

TABLE E-1

TIDAL FLOOD-PRONE COMMUNITIES MARYLAND AND VIRGINIA

<u>MARYLAND</u> ¹	<u>VIRGINIA</u> ²
Cambridge	Cape Charles
Crisfield	Hampton Roads
Pocomoke City	Poquoson
Rock Hall	Tangier Island
Snow Hill	West Point
St. Michaels	
Tilghman Island	

¹ Assessment and evaluation of tidal flood control plans for these communities was conducted by the Baltimore District, Corps of Engineers.

² Assessment and evaluation of tidal flood control plans for these communities was conducted by the Norfolk District, Corps of Engineers.

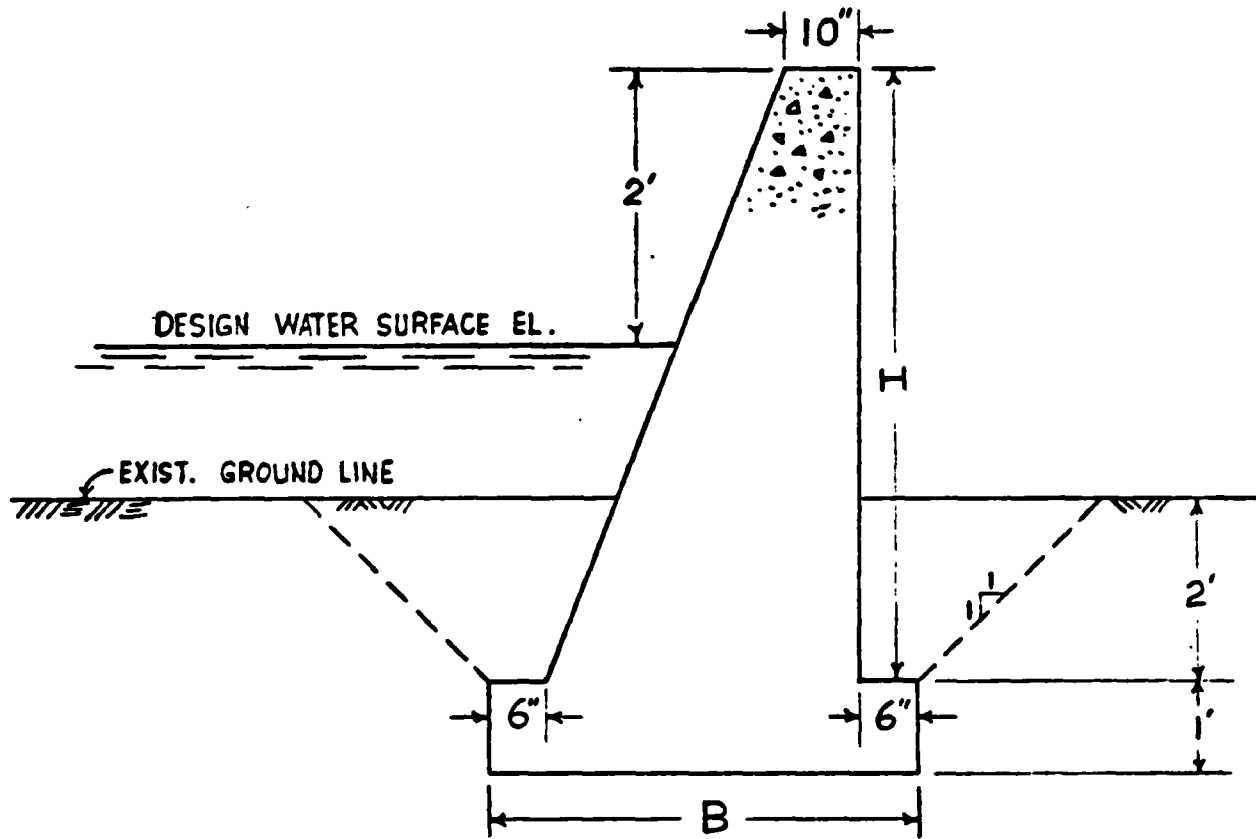

FIGURE E-21 TYPICAL GRAVITY FLOODWALL CROSS SECTION

Alternative measures were examined and structural and nonstructural flood control plans and cost estimates were developed for each community. The cost estimates were prepared for each of the plans to a level of detail sufficient to determine economic feasibility. Costs for items which required extensive data collection and detailed analyses, whether of a structural or nonstructural nature, weren't included in the generalized determination of plan feasibility. Those items that were excluded (e.g., interior drainage for floodwalls, structural analyses for floodproofing) have been addressed in the discussion of individual measures presented in the previous section of this appendix.

Based on the benefit-cost ratios developed, several of these community flood control plans were identified as meriting further study and investigation. The communities identified for further study are located in Virginia and include Cape Charles, Hampton Roads, Poquoson, Tangier Island, and West Point. None of the Maryland communities were examined further because the economic rationale necessary for further evaluation was not sufficient. This is discussed further in Appendix F - Economics.

As the Virginia communities were studied in more detail, the cost estimates presented for each of the Virginia communities plans differ in both detail and price level from the costs developed for the Maryland communities. For this reason, then, a discussion of the cost estimating procedures used for the Maryland communities in 1980 and the Virginia communities in 1983 is presented in the following sections.

MARYLAND COMMUNITIES

The Baltimore District developed cost estimates for both structural and nonstructural flood control alternatives for each of the seven communities studied. Costs for structural alternatives were developed to reflect April 1980 price levels.

Quantities of principal construction items were estimated on the basis of the design features previously discussed. Unit costs were applied to the quantities to arrive at total costs, except for lump sum items. The structural cost estimates include a 30 percent contingency allowance for construction items. Also included is a 20 percent allowance for supervision and administration costs and engineering and design costs to include design studies, design memorandums and plans and specifications.

Nonstructural cost estimates were based on information contained in IWR Pamphlet No. 4, Cost Report on Non-structural Flood Damage Reduction Measures for Residential Buildings within the Baltimore District. After having reviewed these for application to the communities under study, the costs were updated to April 1980 price levels. For residential structures, construction contingencies were estimated to be 20 percent while engineering and design and supervision and administration contingency costs were estimated to be 1 percent.

Commercial structures which required floodproofing or small floodwalls received a 30 percent allowance for construction contingencies while engineering and design and supervision and administration contingency costs were estimated at 20 percent. Real estate values for lands and buildings, whether structural or nonstructural plans, were determined from a review of sales and assessed valuations of commercial, residential, and vacant parcels of land for each community. These real estate values include a 20 percent allowance for contingencies.

Estimates of annual equivalent costs were computed using an interest rate of 7 1/8 percent (Fiscal Year 1980) and include amortization and operation and maintenance costs. A 100-year economic life was assumed in evaluating plans associated with levees, floodwalls, and bulkheads; a 50-year period of analysis was used in estimating annual equivalent costs for all nonstructural alternatives. For a more complete description of the plans and the evaluation process, refer to Appendix B - Plan Formulation, Assessment, and Evaluation.

CAMBRIDGE

A total of eight tidal flood control plans were developed for Cambridge, Maryland. Six structural plans and two nonstructural plans were considered. The structural plans included both a levee and a floodwall with each plan differing in either area or degree of protection. Structural plans CA-1 to CA-3 were designed to protect against flooding up to and including the 120-year event. The differences in cost which are reflected in Tables E-2 through E-4 are due to the length of the levees and floodwalls.

Structural plans CA-4 through CA-6 are also composed of levees and floodwalls. However, these three plans were designed to protect against floods approximating the 500-year event. These plans are the most expensive ranging in costs from \$6.06 million to \$9.12 million as shown in Tables E-5 to E-7.

Two nonstructural plans, CA-7 and CA-8, were developed for the Cambridge area. Plan CA-7 was designed to provide protection against a 40-year flood. This plan required utility additions for five structures, floodproofing of nine structures and construction of a small floodwall. Plan CA-8 protected against the 120-year event by providing for seven utility room additions, floodproofing of 10 structures and construction of an 1,100 foot floodwall. As shown in Tables E-8 and E-9, Plan CA-8 is more than twice as expensive as Plan CA-7. Estimates of annual equivalent charges for the structural and nonstructural plans are shown in Table E-10.

TABLE E-2

CAMBRIDGE COST SUMMARY FOR
STRUCTURAL PLAN CA-1
(120-Year Event - 9 Foot Elevation)
- April 1980 Costs -

DESCRIPTION	QUANTITY	UNIT	UNIT COST	COST	
				FEDERAL	NON-FED
Lands					
Levee	3.5	AC	\$ 20,000	\$ 0	\$ 70,000
Wall	7.9	AC	25,000	0	197,500
Sub-total				0	267,500
Contingencies			20%	0	53,500
Relocations (None)					
Levee (3,430 FT.)					
Stripping	5,150	C.Y.	2.50	12,875	0
Trenching	21,700	C.Y.	2.50	54,250	0
Tot. Embankment	38,900	C.Y.	7.00	272,300	0
Riprap	2,400	C.Y.	103.00	247,200	0
Seed & Sod	10,350	S.Y.	0.45	4,658	0
Clearing	—	JOB	L.S.	10,000	0
Closure Structure	—	JOB	L.S.	105,000	0
Floodwall (12,050 FT.)					
Concrete	14,200	C.Y.	200.00	2,840,000	0
Steel	1,623,100	LB.	0.50	811,550	0
Fill	30,000	C.Y.	3.00	90,000	0
Seed & Sod	240,300	S.Y.	0.45	108,135	0
Excavation	28,900	C.Y.	2.20	63,580	0
Stripping	11,500	C.Y.	2.50	28,750	0
Clearing	—	JOB	L.S.	10,000	0
Closure Structure	—	—	—	—	—
Sub-total				4,658,298	0
Contingencies			30%	1,397,702	0
Sub-total				6,056,000	0
E&D			15%	908,250	0
S&A			5%	302,750	0
Sub-total				\$7,267,000	\$321,000
Total Cost	(April 1980)			\$7,588,000	

AC - acre
C.Y. - cubic yard
LB. - pounds
S.Y. - square yard
L.S. - lump sum

TABLE E-3

CAMBRIDGE COST SUMMARY FOR
STRUCTURAL PLAN CA-2
(120-Year Event - 9 Foot Elevation)
- April 1980 Costs -

<u>DESCRIPTION</u>	<u>QUANTITY</u>	<u>UNIT</u>	<u>UNIT COST</u>	<u>COST</u>	
				<u>FEDERAL</u>	<u>NON-FED</u>
Lands					
Levee	1.61	AC	\$ 20,000	\$ 0	\$ 32,000
Wall	6.4	AC	25,000	0	160,000
Sub-total				0	192,000
Contingencies			20%	0	38,400
Relocations (None)					
Levee (1,610 FT.)					
Stripping	2,400	C.Y.	2.50	6,000	0
Trenching	10,200	C.Y.	2.50	25,500	0
Tot. Embankment	18,000	C.Y.	7.00	126,000	0
Riprap	1,200	C.Y.	103.00	123,600	0
Seed & Sod	4,700	S.Y.	0.45	2,115	0
Clearing	-	JOB	L.S.	10,000	0
Closure Structure	-	JOB	L.S.	90,000	0
Floodwall (9,790 FT.)					
Concrete	11,600	C.Y.	200.00	2,320,000	0
Steel	1,329,100	LB.	0.50	664,550	0
Fill	24,400	C.Y.	3.00	73,200	0
Seed & Sod	195,900	S.Y.	0.45	88,155	0
Excavation	23,600	C.Y.	2.20	51,920	0
Stripping	9,400	C.Y.	2.50	23,500	0
Clearing	-	JOB	L.S.	10,000	0
Closure Structure	-	-	-	-	0
Sub-total				3,614,540	0
Contingencies			30%	1,084,460	0
Sub-total				4,699,000	0
E&D			15%	\$704,850	0
S&A			5%	234,950	0
Sub-total				<u>\$5,638,800</u>	<u>\$230,400</u>
Total Cost	(April 1980)			\$5,869,200	

AC - acre
C.Y. - cubic yard
LB. - pounds
S.Y. - square yard
L.S. - lump sum

TABLE E-4

CAMBRIDGE COST SUMMARY FOR
STRUCTURAL PLAN CA-3
(120-Year Event, 9 Foot Elevation)
- April 1980 Costs -

DESCRIPTION	QUANTITY	UNIT	UNIT COST	COST	
				FEDERAL	NON-FED
Lands					
Levee	0.1	AC	\$ 20,000	0	\$ 2,000
Wall	6.2	AC	25,000	0	155,000
Sub-total				0	157,000
Contingencies			20%	0	31,400
Relocations (None)					
Levee (120 FT.)					
Stripping	125	C.Y.	2.50	320	0
Trenching	760	C.Y.	2.50	1,900	0
Tot. Embankment	1,025	C.Y.	7.00	7,175	0
Riprap	0	C.Y.	103.00	0	0
Seed & Sod	300	S.Y.	L.S.	500	0
Clearing	-	-	-	-	-
Closure Structure	-	-	-	-	-
Floodwall (9,600 FT.)					
Concrete	11,400	C.Y.	200.00	2,280,000	0
Steel	1,304,550	LB.	0.50	652,275	0
Fill	24,000	C.Y.	3.00	72,000	0
Seed & Sod	192,300	S.Y.	0.45	86,535	0
Excavation	23,100	C.Y.	2.20	50,820	0
Stripping	9,200	C.Y.	2.50	23,000	0
Clearing		JOB	L.S.	10,000	0
Closure Structure	-	-	-	-	-
Sub-total				3,184,525	0
Contingencies			30%	955,475	0
Sub-total				4,140,000	0
E&D			15%	\$621,000	0
S&A			5%	207,000	0
Sub-total				<u>\$4,968,000</u>	<u>\$188,400</u>
Total Cost	(April 1980)			\$5,156,400	

AC - acre
C.Y. - cubic yard
LB. - pounds
S.Y. - square yard
L.S. - lump sum

TABLE E-5

CAMBRIDGE COST SUMMARY
 FOR STRUCTURAL PLAN CA-4
 (500-Year Event, 11 Foot Elevation)
 - April 1980 Costs -

<u>DESCRIPTION</u>	<u>QUANTITY</u>	<u>UNIT</u>	<u>UNIT COST</u>	<u>COST</u>	
				<u>FEDERAL</u>	<u>NON-FED</u>
Lands					
Levee	4.6	AC	\$ 20,000	\$ 0	\$ 92,000
Wall	8.3	AC	25,000	0	207,500
Sub-total				0	299,500
Contingencies			20%	0	59,900
Relocations (None)					
Levee (3,534 FT.)					
Stripping	6,800	C.Y.	2.50	17,000	0
Trenching	22,400	C.Y.	2.50	56,000	0
Tot. Embankment	51,600	C.Y.	7.00	361,200	0
Riprap	3,350	C.Y.	103.00	345,050	0
Seed & Sod	13,000	S.Y.	0.45	5,850	0
Clearing	—	JOB	L.S.	10,000	0
Closure Structure	—	JOB	L.S.	170,000	0
Floodwall (12,080 FT.)					
Concrete	16,800	C.Y.	200.00	3,360,000	0
Steel	1,929,300	LB.	0.50	964,650	0
Fill	32,400	C.Y.	3.00	97,200	0
Seed & Sod	262,400	S.Y.	0.45	118,080	0
Excavation	31,400	C.Y.	2.20	69,080	0
Stripping	12,700	C.Y.	2.50	31,750	0
Clearing	—	JOB	L.S.	10,000	0
Closure Structure	—	—	—	—	—
Sub-total				5,615,860	0
Contingencies			30%	1,685,140	0
Sub-total				7,301,000	0
E&D			15%	1,095,150	0
S&A			5%	365,050	0
Sub-total				<u>\$8,761,200</u>	<u>\$359,400</u>
Total Cost	(April 1980)			\$9,120,600	

AC - acre
 C.Y. - cubic yard
 LB. - pounds
 S.Y. - square yard
 L.S. - lump sum

TABLE E-6

CAMBRIDGE COST SUMMARY
FOR STRUCTURAL PLAN CA-5
(500-Year Event, 11 Foot Elevation)
- April 1980 Costs -

<u>DESCRIPTION</u>	<u>QUANTITY</u>	<u>UNIT</u>	<u>UNIT COST</u>	<u>COST</u>	
				<u>FEDERAL</u>	<u>NON-FED</u>
Lands					
Levee	0.6	AC	\$ 20,000	\$ 0	\$ 12,000
Wall	6.8	AC	25,000	0	170,000
Sub-total				0	182,000
Contingencies			20%	0	36,400
Relocations (None)					
Levee (1,720 FT.)					
Stripping	3,100	C.Y.	2.50	7,750	0
Trenching	10,900	C.Y.	2.50	27,250	0
Tot. Embankment	23,700	C.Y.	7.00	165,900	0
Riprap	1,700	C.Y.	103.00	175,100	0
Seed & Sod	6,000	S.Y.	0.45	2,700	0
Clearing	—	JOB	L.S.	10,000	0
Closure Structure	—	JOB	L.S.	160,000	0
Floodwall (9,820 FT.)					
Concrete	13,800	C.Y.	200.00	2,760,000	0
Steel	1,578,100	LB.	0.50	789,050	0
Fill	26,400	C.Y.	3.00	79,200	0
Seed & Sod	214,000	S.Y.	0.45	96,300	0
Excavation	25,600	C.Y.	2.20	56,320	0
Stripping	10,400	C.Y.	2.50	26,000	0
Clearing	—	JOB	L.S.	10,000	0
Closure Structure	—	—	—	—	—
Sub-total				4,365,570	0
Contingencies			30%	1,309,430	0
Sub-total				5,675,000	0
E&D			15%	851,250	0
S&A			5%	283,750	0
Sub-total				\$6,810,000	\$218,400
Total Cost	(April 1980)			\$ 7,028,400	

AC - acre
C.Y. - cubic yard
LB. - pounds
S.Y. - square yard
L.S. - lump sum

TABLE E-7

CAMBRIDGE COST SUMMARY
FOR STRUCTURAL PLAN CA-6
(500-Year Event, 11 Foot Elevation)
- April 1980 Costs -

<u>DESCRIPTION</u>	<u>QUANTITY</u>	<u>UNIT</u>	<u>UNIT COST</u>	<u>COST</u>	
				<u>FEDERAL</u>	<u>NON-FED</u>
Lands					
Levee	0.2	AC	\$ 20,000	\$ 0	\$ 4,000
Wall	6.6	AC	25,000	0	165,000
Sub-total				0	169,000
Contingencies			20%	0	33,800
Relocations (None)					
Levee (210 FT.)					
Stripping	250	C.Y.	2.50	625	0
Trenching	1,300	C.Y.	2.50	3,250	0
Tot. Embankment	2,050	C.Y.	7.00	14,350	0
Riprap	—	C.Y.	—	—	—
Seed & Sod	600	S.Y.	—	1,000	0
Clearing	—	—	—	—	—
Closure Structure	—	—	—	—	—
Floodwall (9,630 FT.)					
Concrete	13,500	C.Y.	200.00	2,700,000	0
Steel	1,547,400	LB.	0.50	773,700	0
Fill	25,950	C.Y.	3.00	77,850	0
Seed & Sod	209,800	S.Y.	0.45	94,410	0
Excavation	25,050	C.Y.	2.20	55,110	0
Stripping	10,200	C.Y.	2.50	25,500	0
Clearing	—	JOB	L.S.	10,000	0
Closure Structure	—	—	—	—	—
Sub-total				3,755,795	0
Contingencies			30%	1,126,205	0
Sub-total				4,882,000	0
E&D			15%	732,300	0
S&A			5%	244,100	0
Sub-total				<u>\$5,858,400</u>	<u>\$202,800</u>
Total Cost	(April 1980)			\$ 6,061,200	

AC - acre
C.Y. - cubic yard
LB. - pounds
S.Y. - square yard
L.S. - lump sum

TABLE E-8
 CAMBRIDGE COST SUMMARY
 FOR NONSTRUCTURAL PLAN CA-7
 (40-Year Event)
 - April 1980 Costs -

DESCRIPTION	COST
<u>Residential</u>	
Utility Additions	
5 Units	\$37,000
Raising	
0 Homes 1'-4"	0
0 Homes 2'-8"	0
0 Homes 4'-0"	0
Relocations	
0 Homes	0
0 Trailers	0
Acquisition & Demolition	
0 Homes	0
Sub-total	37,000
Contingencies @ 20%	7,400
	44,400
E&D,S&A @ 1%	400
Total	\$ 44,800
<u>Commercial</u>	
Acquisition & Demolition	
0 Structures	\$ 0
Raising	
0 Structures 1'-4"	0
0 Structures 2'-8"	0
0 Structures 4'-0"	0
Relocations	
0 Structures	0
Floodproofing	
9 Structures	134,250
Floodwall	
470' Length for 2 Structures	71,850
Sub-total	206,100
Contingencies @ 30%	61,800
	267,900
E&D @ 15%	40,200
S&A @ 5%	13,400
Total	\$ 321,500
Total Cost (April 1980)	\$366,300

TABLE E-9

CAMBRIDGE COST SUMMARY FOR
NONSTRUCTURAL PLAN CA-8
(120-Year Event)
- April 1980 Costs -

<u>DESCRIPTION</u>	<u>COST</u>
<u>Residential</u>	
Utility Additions	
7 Units	\$51,800
Raising	
0 Homes 1'-4"	0
0 Homes 2'-8"	0
0 Homes 4'-0"	0
Relocations	
0 Homes	0
0 Trailers	0
Acquisition & Demolition	
4 Homes	158,800
	Sub-total 210,600
	Contingencies @ 20% 42,100
	252,700
	E&D,S&A @ 1% 2,500
	Total \$ 255,200
<u>Commercial</u>	
Acquisition & Demolition	
0 Structures	\$ 0
Raising	
0 Structures 1'-4"	0
0 Structures 2'-8"	0
0 Structures 4'-0"	0
Relocations	
0 Structures	0
Floodproofing	
10 Structures	160,680
Floodwall	
1,110' Length for 5 Structures	155,950
	Sub-total 316,630
	Contingencies @ 30% 95,000
	411,630
	E&D @ 15% 61,725
	S&A @ 5% 20,575
	Total \$ 493,930
Total Cost (April 1980)	\$749,100

TABLE E-10

CAMBRIDGE FLOOD CONTROL ALTERNATIVES:
ESTIMATES OF ANNUAL EQUIVALENT CHARGES
- April 1980 Costs -

<u>Plan</u>	<u>First Cost</u>	<u>Interest and Amortization Factor*</u>	<u>Interest & Amortization</u>	<u>Operation & ** Maintenance Costs</u>	<u>Total Annual Equivalent Charges</u>
CA-1	\$7,588,000	0.07132	\$ 541,200	\$ 46,600	\$ 587,800
CA-2	5,869,200	0.07132	418,600	36,100	454,700
C -3	5,156,400	0.07132	367,800	31,800	399,600
CA-4	9,120,600	0.07132	650,500	56,200	706,700
CA-5	7,028,400	0.07132	501,300	43,700	545,000
CA-6	6,061,200	0.07132	432,300	37,600	469,900
CA-7	366,300	0.07361	26,700	0	26,700
CA-8	\$ 749,150	0.07361	\$ 55,150	\$ 0	\$ 55,150

* The Interest and Amortization Factor is based on an economic life of 100 years for structural projects (50 years for nonstructural projects) and a Federal interest rate of 7 1/8 percent (FY 1980).

** Estimates of operation and maintenance costs were based on one percent of the construction costs.

CRISFIELD

Six alternative tidal flood protection plans were developed for the community of Crisfield, Maryland. Four structural plans and two nonstructural plans were analyzed. Each of the four structural plans included levee and floodwall protection with estimated costs ranging between \$5.8 million and \$7.3 million based on April 1980 price levels. Structural plans CR-1 and CR-3 were designed to protect against the 80-year flood event through levee and floodwall construction to a top elevation of eight feet. The main difference between these two plans was related to the length of the levees and floodwalls considered. Cost estimates for these two plans are presented in Table E-11 and E-13. Structural plans CR-2 and CR-4 also consisted of levees and floodwalls. Aside from the lengths considered, these plans differed from CR-1 and CR-3 in that the top elevation was increased by one foot. This one foot increment, however, was determined to protect against the 400-year tidal flood event. These two plans were the most expensive of the six plans evaluated as indicated by the cost estimates in Tables E-12 and E-14. Nonstructural plan CR-5, through 1 utility room addition, 3 relocations and 1 demolition, would protect the residential areas against the 12-year flood event. Protection of commercial property to the same degree was based on demolition of 2 structures, a raising of 2 structures, floodproofing of 12 structures and construction of a floodwall to protect 7 more structures. Estimates of the cost of CR-5 are provided in Table E-15.

Table E-16 presents cost information on nonstructural plan CR-6. Elements of residential protection in this plan included addition of 24 utility rooms, 17 relocations and 20 demolitions. The commercial portion of this plan included demolition of 41 structures, raising of 6 structures, floodproofing 61 structures and floodwall construction totalling almost 8,900 feet in length. This nonstructural plan was determined to protect against the 80-year tidal flood at an estimated cost of almost \$6.3 million. Annual equivalent charges for all of the above plans are presented in Table E-17.

TABLE E-11

CRISFIELD COST SUMMARY FOR
STRUCTURAL PLAN CR-1
(80-Year Event, 8 Foot Elevation)
- April 1980 Costs -

DESCRIPTION	QUANTITY	UNIT	UNIT COST	COST	
				FEDERAL	NON-FED
Lands					
Levee	13.8	AC	\$ 15,000	\$ 0	\$ 207,000
Wall	4.6	AC	25,000	0	115,000
Sub-total				0	322,000
Contingencies			20%	0	64,400
Relocations (None)					
Levee (15,340 FT.)					
Stripping	20,000	C.Y.	2.50	50,000	0
Trenching	97,100	C.Y.	2.50	242,750	0
Tot. Embankment	154,000	C.Y.	7.00	1,078,000	0
Riprap	—	C.Y.	—	—	—
Seed & Sod	44,400	S.Y.	0.45	19,980	0
Clearing	—	JOB	L.S.	20,000	0
Closure Structure	—	JOB	L.S.	223,000	0
Floodwall (7,280 FT.)					
Concrete	7,900	C.Y.	200.00	1,580,000	0
Steel	899,800	LB.	0.50	449,900	0
Fill	17,500	C.Y.	3.00	52,500	0
Seed & Sod	139,400	S.Y.	0.45	62,730	0
Excavation	168,200	C.Y.	2.20	370,040	0
Stripping	6,600	C.Y.	2.50	16,500	0
Clearing	—	JOB	L.S.	10,000	0
Closure Structure	—	JOB	L.S.	76,000	0
Sub-total				4,251,400	0
Contingencies			30%	1,275,600	0
Sub-total				5,527,000	0
E&D			15%	829,000	0
S&A			5%	276,350	0
Sub-total				\$6,632,400	\$386,400
Total Cost	(April 1980)			\$ 7,018,800	

AC - acre
C.Y. - cubic yard
LB. - pounds
S.Y. - square yard
L.S. - lump sum

TABLE E-12

CRISFIELD COST SUMMARY FOR
STRUCTURAL PLAN CR-2
(400-Year Event, 9 Foot Elevation)
- April 1980 Costs -

<u>DESCRIPTION</u>	<u>QUANTITY</u>	<u>UNIT</u>	<u>UNIT COST</u>	<u>COST</u>	
				<u>FEDERAL</u>	<u>NON-FED</u>
Lands					
Levee	16.4	AC	\$ 15,000	\$ 0	\$ 246,000
Wall	4.8	AC	25,000	0	120,000
Sub-total				0	366,000
Contingencies			20%	0	73,200
Relocations (None)					
Levee (16,055 FT.)					
Stripping	24,000	C.Y.	2.50	60,000	0
Trenching	101,600	C.Y.	2.50	254,000	0
Tot. Embankment	181,100	C.Y.	7.00	1,267,700	0
Riprap	—	C.Y.	—	—	—
Seed & Sod	51,300	S.Y.	0.45	23,085	0
Clearing	—	JOB	L.S.	20,000	0
Closure Structure	—	JOB	L.S.	283,000	0
Floodwall (7,280 FT)					
Concrete	8,700	C.Y.	200.00	1,740,000	0
Steel	991,900	LB.	0.50	495,950	0
Fill	18,200	C.Y.	3.00	54,600	0
Seed & Sod	145,000	S.Y.	0.45	65,250	0
Excavation	17,500	C.Y.	2.20	38,500	0
Stripping	7,000	C.Y.	2.50	17,500	0
Clearing	—	JOB	L.S.	10,000	0
Closure Structure	—	JOB	L.S.	90,000	0
Sub-total				4,419,585	0
Contingencies			30%	1,325,415	0
Sub-total				5,745,000	0
E&D			15%	861,750	0
S&A			5%	287,250	0
Sub-total				<u>\$6,894,000</u>	<u>\$439,200</u>
Total Cost	(April 1980)			\$ 7,333,200	

AC - acre
C.Y. - cubic yard
LB. - pounds
S.Y. - square yard
L.S. - lump sum

TABLE E-13

CRISFIELD COST SUMMARY FOR
STRUCTURAL PLAN CR-3
(80-Year Event, 8 Foot Elevation)
- April 1980 Costs -

DESCRIPTION	QUANTITY	UNIT	UNIT COST	COST	
				FEDERAL	NON-FED
Lands					
Levee	13.6	AC	\$ 15,000	\$ 0	\$ 204,000
Wall	3.9	AC	25,000	0	97,500
Sub-total				0	301,500
Contingencies			20%	0	60,300
Relocations (None)					
Levee (14,820 FT.)					
Stripping	19,500	C.Y.	2.50	48,750	0
Trenching	93,800	C.Y.	2.50	234,500	0
Tot. Embankment	149,900	C.Y.	7.00	1,049,300	0
Riprap	—	C.Y.	—	—	—
Seed & Sod	43,300	S.Y.	0.45	19,485	0
Clearing	—	JOB	L.S.	20,000	0
Closure Structure	—	JOB	L.S.	193,000	0
Floodwall (6,110 FT.)					
Concrete	6,600	C.Y.	200.00	1,320,000	0
Steel	755,200	LB.	0.50	377,600	0
Fill	14,700	C.Y.	3.00	44,100	0
Seed & Sod	117,000	S.Y.	0.45	52,650	0
Excavation	14,100	C.Y.	2.20	31,020	0
Stripping	5,600	C.Y.	2.50	14,000	0
Clearing	—	JOB	L.S.	10,000	0
Closure Structure	—	JOB	L.S.	76,000	0
Sub-total				3,490,405	0
Contingencies			30%	1,047,595	0
Sub-total				4,538,000	0
E&D			15%	\$680,700	0
S&A			5%	226,900	0
Sub-total				<u>\$5,445,600</u>	<u>\$361,800</u>
Total Cost	(April 1980)				\$ 5,807,400

AC - acre
C.Y. - cubic yard
LB. - pounds
S.Y. - square yard
L.S. - lump sum

TABLE E-14

CRISFIELD COST SUMMARY FOR
STRUCTURAL PLAN CR-4
(400-Year Event, 9 Foot Elevation)
- April 1980 Costs -

DESCRIPTION	QUANTITY	UNIT	UNIT COST	COST	
				FEDERAL	NON-FED
Lands					
Levee	15.9	AC	\$ 15,000	\$ 0	\$ 238,500
Wall	4.0	AC	25,000	0	100,000
Sub-total				0	338,500
Contingencies			20%	0	67,700
Relocations (None)					
Levee (15,535 FT.)					
Stripping	23,400	C.Y.	2.50	58,500	0
Trenching	98,300	C.Y.	2.50	245,750	0
Tot. Embankment	176,500	C.Y.	7.00	1,235,500	0
Riprap	—	C.Y.	—	—	—
Seed & Sod	50,000	S.Y.	0.45	22,500	0
Clearing	—	JOB	L.S.	20,000	0
Closure Structure	—	JOB	L.S.	245,000	0
Floodwall (6,110 FT.)					
Concrete	7,300	C.Y.	200.00	1,460,000	0
Steel	832,500	LB.	0.50	416,250	0
Fill	152,800	C.Y.	3.00	458,400	0
Seed & Sod	122,500	S.Y.	0.45	55,125	0
Excavation	14,700	C.Y.	2.20	32,340	0
Stripping	5,900	C.Y.	2.50	14,750	0
Clearing	—	JOB	L.S.	10,000	0
Closure Structure	—	JOB	L.S.	90,000	0
Sub-total				4,364,115	0
Contingencies			30%	1,309,885	0
Sub-total				5,674,000	0
E&D			15%	851,100	0
S&A			5%	283,700	0
Sub-total				\$6,808,800	\$406,200
Total Cost	(April 1980)			\$ 7,215,000	

AC - acre
C.Y. - cubic yard
LB. - pounds
S.Y. - square yard
L.S. - lump sum

TABLE E-15

CRISFIELD COST SUMMARY FOR
NONSTRUCTURAL PLAN CR-5
(12-Year Event)
-April 1980 Costs-

<u>DESCRIPTION</u>	<u>COST</u>
<u>Residential</u>	
Utility Additions	
<u>1</u> Unit	\$7,400
Raising	
<u>0</u> Homes 1'4"	0
<u>0</u> Homes 2'8"	0
<u>0</u> Homes 4'0"	0
Relocations	
<u>0</u> Homes	0
<u>3</u> Trailers	36,000
Acquisition & Demolition	
<u>1</u> Homes	20,350
	<u>63,750</u>
Sub-total	63,750
Contingencies @ 20%	12,750
	<u>76,500</u>
E&D,S&A @ 1%	800
Total	\$ 77,300
 <u>Commercial</u>	
Acquisition & Demolition	
<u>2</u> Structures	\$ 58,850
Raising	
<u>0</u> Structures 1'-4"	0
<u>2</u> Structures 2'-8"	21,600
<u>0</u> Structures 4'-0"	0
Relocations	
<u>0</u> Structures	0
Floodproofing	
<u>12</u> Structures	98,540
Floodwall	
2,050' Length for 7 Structures	205,000
	<u>383,990</u>
Sub-total	383,990
Contingencies @ 30%	115,200
	<u>499,200</u>
E&D @ 15%	74,850
S&A @ 5%	24,950
Total	\$ 599,000
 Total Cost (April 1980)	 \$676,300

TABLE E-16

CRISFIELD COST SUMMARY FOR
NONSTRUCTURAL PLAN CR-6
(80-Year Event)
- April 1980 Costs -

<u>DESCRIPTION</u>	<u>COST</u>
<u>Residential</u>	
Utility Additions	
<u>24</u> Units	\$177,600
Raising	
<u>0</u> Homes 1'-4"	0
<u>0</u> Homes 2'-8"	0
<u>0</u> Homes 4'-0"	0
Relocations	
<u>0</u> Homes	0
<u>17</u> Trailers	204,000
Acquisition & Demolition	
<u>20</u> Homes	481,100
	<u>Sub-total</u>
	862,700
	Contingencies @ 20%
	172,500
	<u>1,035,200</u>
	E&D, S&A @ 1%
	10,350
	<u>Total</u>
	\$ 1,045,550
<u>Commercial</u>	
Acquisition & Demolition	
<u>41</u> Structures	\$1,792,750
Raising	
<u>6</u> Structures 1'-4"	58,800
<u>0</u> Structures 2'-8"	0
<u>0</u> Structures 4'-0"	0
Relocations	
<u>0</u> Structures	0
Floodproofing	
<u>61</u> Structures	433,240
Floodwall	
8,875' Length for 36 Structures	1,081,750
	<u>Sub-total</u>
	3,366,540
	Contingencies @ 30%
	1,010,000
	<u>4,376,540</u>
	E&D @ 15%
	656,500
	S&A @ 5%
	218,800
	<u>Total</u>
	\$ 5,251,800
 Total Cost (April 1980)	 \$6,297,300

TABLE E-17

CRISFIELD FLOOD CONTROL ALTERNATIVES:
ESTIMATES OF ANNUAL EQUIVALENT CHARGES
- April 1980 Costs -

<u>Plan</u>	<u>First Cost</u>	<u>Interest & Amortization Factor*</u>	<u>Interest & Amortization</u>	<u>Operation & ** Maintenance Costs</u>	<u>Total Annual Equivalent Charges</u>
CR-1	\$7,018,800	0.07132	\$500,600	\$ 42,500	\$543,100
CR-2	7,333,200	0.07132	523,000	44,200	567,200
CR-3	5,807,400	0.07132	414,200	34,900	449,100
CR-4	7,215,000	0.07132	514,600	43,600	558,200
CR-5	676,300	0.07361	49,800	0	49,800
CR-6	\$6,297,300	0.07361	\$463,500	\$ 0	\$463,500

* The Interest and Amortization Factor is based on an economic life of 100 years for structural projects (50 years for nonstructural projects) and a Federal interest rate of 7 1/8 percent (FY 1980).

** Estimates of operation and maintenance costs were based on one percent of the construction costs.

POCOMOKE CITY

Tidal flood protection plans developed for Pocomoke City consisted of two structural plans and three nonstructural plans. Both structural plans PC-1 and PC-2 included levee and floodwall construction. The length of floodwall constructed in both plans was the same (5,630 feet) while plan PC-2 included 310 feet more levee construction than PC-1. Structural Plan PC-1 was based on a top elevation of 9 feet which would protect against the estimated 70-year tidal flood event. Costs of this plan based on April 1980 dollars were approximately \$3.5 million as shown in Table E-18. Plan PC-2 not only included increased levee construction but also was designed to a top elevation of 11 feet. This plan was estimated to protect against events approximating the 500-year tidal flood. Costs of this plan, as shown in Table E-19, approximated \$4.3 million at 1980 price levels.

The nonstructural plans for Pocomoke City were based on making changes to residential and commercial structures in the flood plain. Nonstructural Plan PC-3 included utility room additions to three residences as well as acquisition and demolition of one home. Acquisition and demolition of one commercial structure and construction of 610 feet of floodwall to protect two structures completed this plan. This plan, estimated to cost approximately \$0.26 million, as shown in Table E-20, would protect against the 25-year tidal flood. Nonstructural Plan PC-4, again, was based on alterations to the residential and commercial sectors. A total of seven utility room additions, one house raising, one relocation, and demolition of two homes accounted for approximately 33 percent of the plan cost. The remaining 67 percent of the plan cost reflects the cost of demolishing one commercial structure, floodproofing two structures and floodwall construction of 2,410 feet. Total construction cost of this plan as shown in Table E-21 was estimated to be \$0.73 million and reflects a level of protection approximating the 70-year flood event. Nonstructural Plan PC-5 was designed to protect against the estimated 220-year flood event. The increased protection results from a substantial effort in the residential sector. Because of increased utility additions, raisings, and demolitions, costs of residential protection almost tripled those of PC-4. Total costs of this plan were estimated to be \$1.36 million at April 1980 levels as reflected in Table E-22. Table E-23 summarizes the annual equivalent costs associated with the plans for Pocomoke City.

TABLE E-18

POCOMOKE CITY COST SUMMARY FOR
 STRUCTURAL PLAN PC-1
 (70-Year Event, 9 Foot Elevation)
 - April 1980 Costs -

DESCRIPTION	QUANTITY	UNIT	UNIT COST	COST	
				FEDERAL	NON-FED
Lands					
Levee	3.9	AC	\$ 10,000	\$ 0	\$ 39,000
Wall	3.6	AC	12,000	0	43,200
Sub-total				0	82,200
Contingencies			20%	0	16,440
Relocations (None)					
Levee (4,560 FT.)					
Stripping	5,700	C.Y.	2.50	14,250	0
Trenching	28,800	C.Y.	2.50	72,000	0
Tot. Embankment	43,900	C.Y.	7.00	307,300	0
Riprap	—	C.Y.	—	—	—
Seed & Sod	12,700	S.Y.	0.45	5,715	0
Clearing	—	JOB	L.S.	20,000	0
Closure Structure	—	JOB	L.S.	70,000	0
Floodwall (5,630 FT.)					
Concrete	6,080	C.Y.	200.00	1,216,000	0
Steel	695,900	LB.	0.50	347,950	0
Fill	13,500	C.Y.	3.00	40,500	0
Seed & Sod	107,800	S.Y.	0.45	48,510	0
Excavation	13,000	C.Y.	2.50	32,500	0
Stripping	5,100	C.Y.	2.50	12,750	0
Clearing	—	JOB	L.S.	20,000	0
Closure Structure	—	—	—	—	—
Sub-total				2,207,475	0
Contingencies			30%	662,525	0
Sub-total				2,870,000	0
E&D			15%	430,500	0
S&A			5%	143,500	0
Sub-total				\$3,444,000	\$98,640
Total Cost	(April 1980)			\$ 3,542,600	

AC - acre
 C.Y. - cubic yard
 LB. - pound
 S.Y. - square yard
 L.S. - lump sum

TABLE E-19

POCOMOKE CITY COST SUMMARY FOR
STRUCTURAL PLAN PC-2
(500-Year Event, 11 Foot Elevation)
- April 1980 Costs -

DESCRIPTION	QUANTITY	UNIT	UNIT COST	COST	
				FEDERAL	NON-FED
Lands					
Levee	5.25	AC	\$10,000	\$ 0	\$52,500
Wall	3.8	AC	12,000	0	45,600
Sub-total				0	98,100
Contingencies			20%	0	19,620
Relocations (None)					
Levee (4,870 FT.)					
Stripping	7,870	C.Y.	2.50	19,675	0
Trenching	30,770	C.Y.	2.50	76,925	0
Tot. Embankment	59,405	C.Y.	7.00	415,835	0
Riprap	—	C.Y.	—	—	—
Seed & Sod	16,590	S.Y.	0.45	7,466	0
Clearing	—	JOB	L.S.	20,000	0
Closure Structure	—	JOB	L.S.	110,000	0
Floodwall (5,630 FT.)					
Concrete	7,300	C.Y.	200.00	1,460,000	0
Steel	838,300	LB.	0.50	419,150	0
Fill	14,600	C.Y.	3.00	43,800	0
Seed & Sod	117,900	S.Y.	0.45	53,055	0
Excavation	14,100	C.Y.	2.50	35,250	0
Stripping	5,700	C.Y.	2.50	14,250	0
Clearing	—	JOB	L.S.	20,000	0
Closure Structure	—	—	—	—	—
Sub-total				2,695,406	0
Contingencies			30%	808,594	0
Sub-total				3,504,000	0
E&D			15%	525,750	0
S&A			5%	175,250	0
Sub-total				\$4,205,000	\$117,720
Total Cost	(April 1980)			\$ 4,322,700	

AC - acre
C.Y. - cubic yard
LB. - pound
S.Y. - square yard
L.S. - lump sum

TABLE E-20

POCOMOKE CITY COST SUMMARY FOR
NONSTRUCTURAL PLAN PC-3
(25-Year Event)
- April 1980 Costs -

<u>DESCRIPTION</u>	<u>COST</u>
<u>Residential</u>	
Utility Additions	
<u>3</u> Units	\$ 22,200
Raising	
<u>0</u> Homes 1'-4"	0
<u>0</u> Homes 2'-8"	0
<u>0</u> Homes 4'-0"	0
Relocations	
<u>0</u> Homes	0
<u>0</u> Trailers	0
Acquisition & De.nolition	
<u>1</u> Home	35,000
	<u>57,200</u>
Sub-total	57,200
Contingencies @ 20%	11,400
	<u>68,600</u>
E&D, S&A @ 1%	700
Total	<u>\$ 69,300</u>
<u>Commercial</u>	
Acquisition & Demolition	
<u>1</u> Structure	\$ 61,100
Raising	
<u>0</u> Structures 1'-4"	0
<u>0</u> Structures 2'-8"	0
<u>0</u> Structures 4'-0"	0
Relocations	
<u>0</u> Structures	0
Floodproofing	
<u>0</u> Structures	0
Floodwall	
610' Length for 2 Structures	61,000
	<u>122,100</u>
Sub-total	122,100
Contingencies @ 30%	36,600
	<u>158,700</u>
E&D @ 15%	\$ 23,800
S&A @ 5%	7,900
Total	<u>\$ 190,400</u>
Total Cost (April 1980)	<u>\$259,700</u>

TABLE E-21

POCOMOKE CITY COST SUMMARY FOR
NONSTRUCTURAL PLAN PC-4
(70-Year Event)
-April 1980 Costs-

<u>DESCRIPTION</u>	<u>COST</u>
<u>Residential</u>	
Utility Additions	
<u>7</u> Units	\$ 51,800
Raising	
<u>1</u> Home 1'-4"	9,800
<u>0</u> Homes 2'-8"	0
<u>0</u> Homes 4'-0"	0
Relocations	
<u>0</u> Homes	0
<u>1</u> Trailer	6,000
Acquisition & Demolition	
<u>2</u> Homes	80,000
	<u>147,600</u>
Sub-total	147,600
Contingencies @ 20%	29,500
	<u>177,100</u>
E&D, S&A @ 1%	1,800
Total	<u>\$ 178,900</u>
<u>Commercial</u>	
Acquisition & Demolition	
<u>1</u> Structure	\$ 61,100
Raising	
<u>0</u> Structures 1'-4"	0
<u>0</u> Structures 2'-8"	0
<u>0</u> Structures 4'-0"	0
Relocations	
<u>0</u> Structures	0
Floodproofing	
<u>2</u> Structures	33,700
Floodwall	
2,410' Length for 3 Structures	257,500
	<u>352,300</u>
Sub-total	352,300
Contingencies @ 30%	105,700
	<u>458,000</u>
E&D @ 15%	68,700
S&A @ 5%	22,900
Total	<u>\$ 549,600</u>
Total Cost (April 1980)	\$728,500

TABLE E-22

POCOMOKE CITY COST SUMMARY FOR
NONSTRUCTURAL PLAN PC-5
(220-Year Event)
- April 1980 Costs -

<u>DESCRIPTION</u>	<u>COST</u>
<u>Residential</u>	
Utility Additions	
<u>16</u> Units	\$ 118,400
Raising	
<u>5</u> Homes 1'-4"	51,200
<u>1</u> Homes 2'-8"	10,800
<u>0</u> Homes 4'-0"	0
Relocations	
<u>0</u> Homes	0
<u>1</u> Trailer	6,000
Acquisition & Demolition	
<u>6</u> Homes	<u>224,700</u>
	Sub-total
	411,100
	Contingencies @ 20%
	82,200
	<u>493,300</u>
	E&D, S&A @ 1%
	4,900
	Total
	\$ <u>498,200</u>
 <u>COMMERCIAL</u>	
Acquisitions & Demolition	
<u>2</u> Structures	\$ 87,200
Raising	
<u>1</u> Structures 1'-4"	7,700
<u>0</u> Structures 2'-8"	0
<u>0</u> Structures 4'-0"	0
Relocations	
<u>0</u> Structures	0
Floodproofing	
<u>5</u> Structures	58,000
Floodwall	
2,410' Length for 3 Structures	<u>397,700</u>
	Sub-total
	550,600
	Contingencies @ 30%
	165,200
	<u>715,800</u>
	E&D @ 15%
	107,400
	S&A @ 5%
	35,800
	Total
	\$ <u>859,000</u>
 Total Cost (April 1980)	 \$1,357,200

TABLE E-23
 POCOMOKE CITY FLOOD CONTROL ALTERNATIVES:
 ESTIMATES OF ANNUAL EQUIVALENT CHARGES
 - April 1980 Costs -

<u>Plan</u>	<u>First Cost</u>	<u>Interest & Amortization Factor *</u>	<u>Interest & Amortization</u>	<u>Operation & ** Maintenance Costs</u>	<u>Total Annual Equivalent Charges</u>
PC-1	\$ 3,542,600	0.07132	\$ 252,700	\$ 22,100	\$ 274,800
PC-2	4,322,700	0.07132	308,300	27,000	335,300
PC-3	259,700	0.07361	19,100	0	19,100
PC-4	728,500	0.07361	53,600	0	53,600
PC-5	\$ 1,357,200	0.07361	\$ 99,900	\$ 0	\$ 99,900

* The Interest and Amortization Factor is based on an economic life of 100 years for structural projects (50 years for nonstructural projects) and a Federal interest rate of 7 1/8 percent (FY 1980).

** Estimates of operation and maintenance costs were based on one percent of the construction costs.

ROCK HALL

During the investigation of tidal flooding problems in the community of Rock Hall, ten alternative flood protection plans were developed. Six of these plans were structural in design including both levee and floodwall construction. Structural Plans RH-1 and RH-2 both included 9,575 feet of floodwall construction while Plan RH-2 included an additional 3,100 feet of levee construction. Furthermore, Plan RH-2 had a top elevation of 15 feet - 3 feet more than Plan RH-1. These design differences translated into the following: Plan RH-1 was designed to provide protection against the 140-year tidal flood event at an April 1980 cost of \$9.45 million while Plan RH-2 was designed to protect against an event approximating the 500-year occurrence at an estimated cost of \$13.51 million. Plan cost information is presented in Tables E-24 and E-25.

Structural Plans RH-3 and RH-4 also provided protection against the 140-year event and the approximate 500-year event, respectively. Both of these plans included for 7,370 feet of floodwall construction and 8,660 feet of levee construction. At an April 1980 estimated cost of \$10.31 million, Structural Plan RH-4 exceeded the cost of Structural Plan RH-3 by more than \$2.3 million. The major reason for this is that Plan RH-4, at 15 feet top elevation, is 3 feet greater in height than Plan RH-3. Itemized costs of these two plans are presented in Tables E-26 and E-27.

Of the six structural plans, Plans RH-5 and RH-6 are the least expensive. Designed to protect against the 140-year tidal flood event, Plan RH-5 is based on 2,205 feet of floodwall construction and 7,700 feet of levee construction for an April 1980 estimated cost of \$3.29 million. Plan RH-6, which was designed to protect against tidal floods approximating the 500-year event, also includes 2,205 feet of floodwall construction plus 9,450 feet of levee construction. However, with a top elevation of 15 feet, Plan RH-6, at \$4.8 million in April 1980 dollars, costs \$1.5 million more than Plan RH-5. Tables E-28 and E-29 present estimated costs for Structural Plans RH-5 and RH-6, respectively.

Four nonstructural plans were also developed for Rock Hall. Nonstructural Plan RH-7 is the least expensive and provides the least amount of protection. In terms of residential and commercial impact, this plan was determined to require 7 structure relocations, floodproofing of 6 structures, acquisition and demolition of 4 homes, and 2,900 feet of floodwall construction to provide protection against the 15-year event. Plan costs, in April 1980 dollars, were estimated to be \$1.09 million as shown in Table E-30. Nonstructural Plan RH-8 was designed to protect against the 25-year tidal event through residential and commercial relocations, raisings, acquisition and demolition of 20 structures, and 3,500 feet of floodwall construction. Estimated April 1980 costs of Plan RH-8 are \$2.5 million as itemized in Table E-31.

Nonstructural Plan RH-9 provides protection against the 50-year tidal event at an estimated April 1980 cost of \$4.86 million. This plan includes acquisition and demolition of 58 structures, relocation of 18 structures, floodproofing, house raisings, and floodwall construction in the amount of 3,500 feet. Costs of this plan are shown in Table E-32. Nonstructural Plan RH-10 provides protection against the 80-year tidal flood event. With regard to the commercial sector, the only difference between Plans RH-9 and RH-10 is the increased height of the floodwall design in Plan RH-10. To protect the residential sector against the 80-year event, additional raisings and relocations, and a significant number of acquisitions and demolitions would be necessary. Estimated costs of Plan RH-10 are \$7.15 million and these costs are shown in Table E-33. Table E-34 summarizes the annual costs of Plans RH-1 through RH-10.

TABLE E-24

ROCK HALL COST SUMMARY FOR
STRUCTURAL PLAN RH-1
(140-Year Event, 12 Foot Elevation)
- April 1980 Costs-

<u>DESCRIPTION</u>	<u>QUANTITY</u>	<u>UNIT</u>	<u>UNIT COST</u>	<u>COST</u>	
				<u>FEDERAL</u>	<u>NON-FED</u>
Lands					
Levee	17.4	AC	\$ 15,000	\$ 0	\$ 261,000
Wall	6.8	AC	20,000	0	136,000
Sub-total				0	397,000
Contingencies			20%	0	79,400
Relocations (None)					
Levee (12,840 FT.)					
Stripping	26,100	C.Y.	2.50	65,250	0
Trenching	81,300	C.Y.	2.50	203,250	0
Tot. Embankment	200,900	C.Y.	7.00	1,406,300	0
Riprap	—	C.Y.	—	—	—
Seed & Sod	51,400	S.Y.	0.45	23,130	0
Clearing	—	JOB	L.S.	15,000	0
Closure Structure	—	JOB	L.S.	160,000	0
Floodwall (9,575 FT.)					
Concrete	14,000	C.Y.	200.00	2,800,000	0
Steel	1,603,500	LB.	0.50	801,750	0
Fill	25,900	C.Y.	3.00	77,700	0
Seed & Sod	213,200	S.Y.	0.45	95,940	0
Excavation	25,400	C.Y.	2.20	55,880	0
Stripping	10,400	C.Y.	2.50	26,000	0
Clearing	—		L.S.	25,000	0
Closure Structure	—	—	—	—	—
Sub-total				5,755,200	0
Contingencies			30%	1,726,800	0
Sub-total				7,482,000	0
E&D			15%	1,122,300	0
S&A			5%	374,100	0
Sub-total				\$8,978,400	\$476,400
Total Cost	(April 1980)			\$ 9,454,800	

AC - acre
C.Y. - cubic yard
LB. - pound
S.Y. - square yard
L.S. - lump sum

TABLE E-25

ROCK HALL COST SUMMARY
FOR STRUCTURAL PLAN RH-2
(500-Year Event, 15 Foot Elevation)
- April 1980 Costs-

DESCRIPTION	QUANTITY	UNIT	UNIT COST	COST	
				FEDERAL	NON-FED
Lands					
Levee	26.3	AC	\$ 15,000	\$ 0	\$ 394,500
Wall	7.4	AC	20,000	0	148,000
Sub-total				0	542,500
Contingencies			20%	0	108,500
Relocations (None)					
Levee (15,940 FT.)					
Stripping	40,200	C.Y.	2.50	100,500	0
Trenching	100,900	C.Y.	2.50	252,250	0
Tot. Embankment	334,700	C.Y.	7.00	2,342,900	0
Riprap	5,200	C.Y.	80.00	416,000	0
Seed & Sod	76,300	S.Y.	0.45	34,335	0
Clearing	--	JOB	L.S.	20,000	0
Closure Structure	--	JOB	L.S.	344,000	0
Floodwall (9,575 FT.)					
Concrete	17,200	C.Y.	200.00	3,440,000	0
Steel	1,966,900	LB.	0.50	983,450	0
Fill	29,200	C.Y.	3.00	87,600	0
Seed & Sod	239,100	S.Y.	0.45	107,595	0
Excavation	28,300	C.Y.	2.20	62,260	0
Stripping	11,800	C.Y.	2.50	29,500	0
Clearing	--	JOB	L.S.	25,000	0
Closure Structure	--	--	--	--	0
Sub-total				8,245,390	0
Contingencies			30%	2,473,610	0
Sub-total				10,719,000	0
E&D			15%	1,607,850	0
S&A			5%	535,950	0
Sub-total				<u>\$12,862,800</u>	<u>\$651,000</u>
Total Cost	(April 1980)			\$13,513,800	

AC - acre
C.Y. - cubic yard
LB. - pound
S.Y. - square yard
L.S. - lump sum

TABLE E-26

ROCK HALL COST SUMMARY
FOR STRUCTURAL PLAN RH-3
(140-Year Event, 12 foot elevation)
- April 1980 Costs -

<u>DESCRIPTION</u>	<u>QUANTITY</u>	<u>UNIT</u>	<u>UNIT COST</u>	<u>COST</u>	
				<u>FEDERAL</u>	<u>NON-FED</u>
Lands					
Levee	12.8	AC	\$ 15,000	\$ 0	\$ 192,000
Wall	5.2	AC	20,000	0	104,000
Sub-total				0	296,000
Contingencies			20%	0	59,200
Relocations (None)					
Levee (8,660 FT.)					
Stripping	19,300	C.Y.	2.50	48,250	0
Trenching	54,800	C.Y.	2.50	137,000	0
Tot. Embankment	149,900	C.Y.	7.00	1,049,300	0
Riprap	3,700	C.Y.	80.00	296,000	0
Seed & Sod	37,100	S.Y.	0.45	16,695	0
Clearing	--	JOB	L.S.	10,000	0
Closure Structure	--	JOB	L.S.	320,000	0
Floodwall (7,370 FT.)					
Concrete	10,900	C.Y.	200.00	2,180,000	0
Steel	1,247,300	LB.	0.50	623,650	0
Fill	19,900	C.Y.	3.00	59,700	0
Seed & Sod	165,100	S.Y.	0.45	74,295	0
Excavation	19,400	C.Y.	2.20	42,680	0
Stripping	8,000	C.Y.	2.50	20,000	0
Clearing	--	JOB	L.S.	20,000	0
Closure Structure	--	--	--	--	--
Sub-total				4,897,570	0
Contingencies			30%	1,469,430	0
Sub-total				6,367,000	0
E&D			15%	955,050	0
S&A			5%	318,350	0
Sub-total				<u>\$7,640,400</u>	<u>\$355,200</u>
Total Cost	(April 1980)				\$ 7,995,600

AC - acre
C.Y. - cubic yard
LB. - pound
S.Y. - square yard
L.S. - lump sum

TABLE E-27

**ROCK HALL COST SUMMARY
FOR STRUCTURAL PLAN RH-4
(500-Year Event, 15 Foot Elevation)
- April 1980 Costs -**

<u>DESCRIPTION</u>	<u>QUANTITY</u>	<u>UNIT</u>	<u>UNIT COST</u>	<u>COST</u>	
				<u>FEDERAL</u>	<u>NON-FED</u>
Lands					
Levee	16.3	AC	\$ 15,000	\$ 0	\$ 244,500
Wall	5.7	AC	20,000	0	114,000
Sub-total				0	358,500
Contingencies			20%	0	71,700
Relocations (None)					
Levee (8,660 FT.)					
Stripping	25,100	C.Y.	2.50	62,750	0
Trenching	54,800	C.Y.	2.50	137,000	0
Tot. Embankment	216,000	C.Y.	7.00	1,512,000	0
Riprap	5,200	C.Y.	80.00	416,000	0
Seed & Sod	46,200	S.Y.	0.45	20,790	0
Clearing	—	JOB	L.S.	10,000	0
Closure Structure	—	JOB	L.S.	508,000	0
Floodwall (7,370 FT.)					
Concrete	13,300	C.Y.	200.00	2,660,000	0
Steel	1,527,000	LB.	0.50	763,500	0
Fill	22,600	C.Y.	3.00	67,800	0
Seed & Sod	185,000	S.Y.	0.45	83,250	0
Excavation	21,900	C.Y.	2.20	48,180	0
Stripping	9,100	C.Y.	2.50	22,750	0
Clearing	—	JOB	L.S.	20,000	0
Closure Structure	—	—	—	—	—
Sub-total				6,332,020	0
Contingencies			30%	1,899,980	0
Sub-total				8,232,000	0
E&D			15%	1,234,500	0
S&A			5%	411,500	0
Sub-total				<u>\$9,878,000</u>	<u>\$430,200</u>
Total Cost	(April 1980)			\$ 10,308,200	

AC - acre
C.Y. - cubic yard
LB. - pound
S.Y. - square yard
L.S. - lump sum

116

TABLE E-28

ROCK HALL COST SUMMARY
 FOR STRUCTURAL PLAN RH-5
 (140-Year Event, 12 Foot Elevation)
 - April 1980 Costs -

DESCRIPTION	QUANTITY	UNIT	UNIT COST	COST	
				FEDERAL	NON-FED
Lands					
Levee	9.7	AC	\$ 15,000	\$ 0	\$ 145,500
Wall	1.5	AC	20,000	0	30,000
Sub-total				0	175,500
Contingencies			20%	0	35,100
Relocations (None)					
Levee (7,700 FT.)					
Stripping	14,400	C.Y.	2.50	36,000	0
Trenching	48,700	C.Y.	2.50	121,750	0
Tot. Embankment	109,000	C.Y.	7.00	763,000	0
Riprap	—	C.Y.	—	—	—
Seed & Sod	29,200	S.Y.	0.45	13,140	0
Clearing	—	JOB	L.S.	15,000	0
Closure Structure	—	JOB	L.S.	160,000	0
Floodwall (2,205 FT.)					
Concrete	3,100	C.Y.	200.00	620,000	0
Steel	356,200	LB.	0.50	178,100	0
Fill	6,000	C.Y.	3.00	18,000	0
Seed & Sod	48,200	S.Y.	0.45	21,690	0
Excavation	5,800	C.Y.	2.20	12,760	0
Stripping	2,300	C.Y.	2.50	5,750	0
Clearing	—	JOB	L.S.	10,000	0
Closure Structure	—	—	—	—	—
Sub-total				1,975,190	0
Contingencies			30%	592,810	0
Sub-total				2,568,000	0
E&D			15%	384,750	0
S&A			5%	128,250	0
Sub-total				\$3,081,000	\$210,600
Total Cost	(April 1980)			\$ 3,291,600	

AC - acre
 C.Y. - cubic yard
 LB. - pound
 S.Y. - square yard
 L.S. - lump sum

TABLE E-29

ROCK HALL COST SUMMARY
FOR STRUCTURAL PLAN RH-6
(500-Year Event, 15 Foot Elevation)
- April 1980 Costs -

<u>DESCRIPTION</u>	<u>QUANTITY</u>	<u>UNIT</u>	<u>UNIT COST</u>	<u>COST</u>	
				<u>FEDERAL</u>	<u>NON-FED</u>
Lands					
Levee	14.3	AC	\$ 15,000	\$ 0	\$ 214,500
Wall	1.7	AC	20,000	0	34,000
Sub-total				0	248,500
Contingencies			20%	0	49,700
Relocations (None)					
Levee (9,450 FT.)					
Stripping	21,800	C.Y.	2.50	54,500	0
Trenching	59,800	C.Y.	2.50	149,500	0
Tot. Embankment	177,400	C.Y.	7.00	1,241,800	0
Riprap	—	C.Y.	—	—	—
Seed & Sod	42,400	S.Y.	0.45	19,080	0
Clearing	—	JOB	L.S.	20,000	0
Closure Structure	—	JOB	L.S.	344,000	0
Floodwall (2,205 FT.)					
Concrete	3,800	C.Y.	200.00	760,000	0
Steel	439,900	LB.	0.50	219,950	0
Fill	6,600	C.Y.	3.00	19,800	0
Seed & Sod	54,100	S.Y.	0.45	24,345	0
Excavation	6,400	C.Y.	2.20	14,080	0
Stripping	2,700	C.Y.	2.50	6,750	0
Clearing	—	JOB	L.S.	10,000	0
Closure Structure	—	—	—	—	—
Sub-total				2,883,805	0
Contingencies			30%	865,195	0
Sub-total				3,749,000	0
E&D			15%	562,350	0
S&A			5%	187,450	0
Sub-total				\$4,498,800	\$298,200
Total Cost	(April 1980)			\$ 4,797,000	

AC - acre
C.Y. - cubic yard
LB. - pound
S.Y. - Square yard
L.S. - lump sum

TABLE E-30

ROCK HALL COST SUMMARY
 FOR NONSTRUCTURAL PLAN RH-7
 (15-Year Event)
 - April 1980 Costs -

<u>DESCRIPTION</u>	<u>COST</u>
<u>Residential</u>	
Utility Additions	
<u>1</u> Unit	\$ 7,400
Raising	
<u>0</u> Homes 1'-4"	0
<u>0</u> Homes 2'-8"	0
<u>0</u> Homes 4'-0"	0
Relocations	
<u>0</u> Homes	0
<u>6</u> Trailers	72,000
Acquisition & Demolition	
<u>4</u> Homes	214,800
	<u>294,200</u>
Sub-total	294,200
Contingencies @ 20%	58,800
	<u>353,000</u>
E&D, S&A @ 1%	3,500
Total	<u>\$ 356,500</u>
 <u>Commercial</u>	
Acquisition & Demolition	
<u>0</u> Structures	\$ 0
Raising	
<u>0</u> Structures 1'-4"	0
<u>0</u> Structures 2'-8"	0
<u>0</u> Structures 4'-0"	0
Relocations	
<u>1</u> Structure	13,450
Floodproofing	
<u>6</u> Structures	51,200
Floodwall	
2,942' Length for 10 Structures	407,500
	<u>472,150</u>
Sub-total	472,150
Contingencies @ 30%	141,600
	<u>613,750</u>
E&D @ 15%	92,100
S&A @ 5%	30,650
Total	<u>\$ 736,500</u>
 Total Cost (April 1980)	 <u>\$1,093,000</u>

TABLE E-31

ROCK HALL COST SUMMARY
 FOR NONSTRUCTURAL PLAN RH-8
 (25-Year Event)
 - April 1980 Costs -

<u>DESCRIPTION</u>	<u>COST</u>
<u>Residential</u>	
Utility Additions	
<u>3</u> Units	\$ 22,200
Raising	
<u>0</u> Homes 1'-4"	0
<u>1</u> Home 2'-8"	8,500
<u>0</u> Homes 4'-0"	0
Relocations	
<u>0</u> Homes	0
<u>13</u> Trailers	156,000
Acquisition & Demolition	
<u>18</u> Homes	709,100
	<u>895,800</u>
Sub-total	895,800
Contingencies @ 20%	179,200
	<u>1,075,000</u>
E&D, S&A @ 1%	10,750
Total	<u>\$ 1,085,750</u>
<u>Commercial</u>	
Acquisition & Demolition	
<u>2</u> Structures	\$ 239,700
Raising	
<u>0</u> Structures 1'-4"	0
<u>0</u> Structures 2'-8"	0
<u>0</u> Structures 4'-0"	0
Relocations	
<u>1</u> Structure	13,450
Floodproofing	
<u>5</u> Structures	56,600
Floodwall	
3,552' Length for 14 Structures	599,700
	<u>909,450</u>
Sub-total	909,450
Contingencies @ 30%	272,800
	<u>1,182,250</u>
E&D @ 15%	177,350
S&A @ 5%	59,100
Total	<u>\$ 1,418,700</u>
 Total Cost (April 1980)	 \$ 2,504,450

TABLE E-32

ROCK HALL COST SUMMARY
FOR NONSTRUCTURAL PLAN RH-9
(50-Year Event)
- April 1980 Costs -

<u>DESCRIPTION</u>	<u>COST</u>
<u>Residential</u>	
Utility Additions	
<u>3</u> Units	\$ 22,200
Raising	
<u>1</u> Home 1'-4"	8,500
<u>3</u> Homes 2'-8"	37,500
<u>1</u> Home 4'-0"	14,200
Relocations	
<u>1</u> Home	121,000
<u>16</u> Trailers	192,000
Acquisition & Demolition	
<u>56</u> Homes	2,184,000
	<u>2,579,400</u>
	Sub-total
	Contingencies @ 20%
	515,900
	<u>3,095,300</u>
	E&D, S&A @ 1%
	30,950
	<u>Total</u>
	\$ 3,126,250
<u>Commercial</u>	
Acquisition & Demolition	
<u>2</u> Structures	\$ 239,700
Raising	
<u>0</u> Structures 1'-4"	0
<u>0</u> Structures 2'-8"	0
<u>0</u> Structures 4'-0"	0
Relocations	
<u>1</u> Structure	13,450
Floodproofing	
<u>10</u> Structures	99,800
Floodwall	
3,552' Length for 13 Structures	757,400
	<u>1,110,350</u>
	Sub-total
	Contingencies @ 30%
	333,100
	<u>1,443,450</u>
	E&D @ 15%
	216,500
	S&A @ 5%
	72,200
	<u>Total</u>
	\$ 1,732,150
 Total Cost (April 1980)	 \$4,858,400

TABLE E-33

ROCK HALL COST SUMMARY
FOR NONSTRUCTURAL PLAN RH-10
(80-Year Event)
- April 1980 Costs -

<u>DESCRIPTION</u>	<u>COST</u>
<u>Residential</u>	
Utility Additions	
7 Units	\$ 51,800
Raising	
0 Homes 1'-4"	0
13 Homes 2'-8"	138,600
1 Home 4'-0"	11,600
Relocations	
2 Homes	152,000
26 Trailers	312,000
Acquisition & Demolition	
91 Homes	3,549,000
	<u>4,215,000</u>
Sub-total	4,215,000
Contingencies @ 20%	843,000
	<u>5,058,000</u>
E&D, S&A @ 1%	50,600
Total	\$ <u>5,108,600</u>
 <u>Commercial</u>	
Acquisition & Demolition	
2 Structures	\$ 239,700
Raising	
0 Structures 1'-4"	0
0 Structures 2'-8"	0
0 Structures 4'-0"	0
Relocations	
1 Structure	13,450
Floodproofing	
10 Structures	108,720
Floodwall	
3,552' Length for 13 Structures	943,900
	<u>1,305,770</u>
Sub-total	1,305,770
Contingencies @ 30%	391,730
	<u>1,697,500</u>
E&D @ 15%	254,600
S&A @ 5%	84,900
Total	\$ <u>2,037,000</u>
 Total Cost (April 1980)	 \$ 7,145,600

TABLE E-34

ROCK HALL FLOOD CONTROL ALTERNATIVES:
ESTIMATES OF ANNUAL EQUIVALENT CHARGES
- April 1980 Costs -

<u>Plan</u>	<u>First Cost</u>	<u>Interest & Amortization Factor*</u>	<u>Interest & Amortization</u>	<u>Operation & ** Maintenance Costs</u>	<u>Total Annual Equivalent Charges</u>
RH-1	\$ 9,454,800	0.07132	\$ 674,300	\$ 57,600	\$ 731,900
RH-2	13,513,800	0.07132	963,800	82,500	1,046,300
RH-3	7,995,600	0.07132	570,200	49,000	619,200
RH-4	10,308,200	0.07132	735,200	63,300	798,500
RH-5	3,291,600	0.07132	234,800	19,800	254,600
RH-6	4,797,000	0.07132	342,100	28,800	370,900
RH-7	1,093,000	0.07361	80,500	0	80,500
RH-8	2,504,450	0.07361	184,350	0	184,350
RH-9	4,858,400	0.07361	357,600	0	357,600
RH-10	\$ 7,145,600	0.07361	\$ 526,000	\$ 0	\$ 526,000

* The Interest and Amortization Factor is based on an economic life of 100 years for structural projects (50 years for nonstructural projects) and a Federal interest rate of 7 1/8 percent (FY 1980).

** Estimates of operation and maintenance costs were based on one percent of the construction costs.

SNOW HILL

A total of seven plans, four structural and three nonstructural, were developed during the analysis of tidal flooding in Snow Hill, Maryland. Structural Plans SH-1 and SH-2 were designed to protect against the 70-year tidal flood event. Both plans include levee and floodwall construction to a top elevation of nine feet. Both of these plans also include floodwall construction in the amount of 5,680 linear feet with excavation work being the only cost differential. Structural Plan SH-1 includes 1,510 linear feet of levee construction, which is 1,110 feet more than that of Plan SH-2. Estimated costs of Plans SH-1 and SH-2, in April 1980 dollars, are \$3.01 million and \$2.84 million, respectively. These costs are listed in Tables E-35 and E-36, respectively.

To protect against flood events approximating the 500 year occurrence, both structural Plans SH-3 and SH-4 were designed with a top elevation of 11 feet. Construction of 5,840 linear feet of floodwall is common to both of these plans. However, Plan SH-3 includes construction of 2,080 feet of levee which is more than three times the amount included in Plan SH-4. The April 1980 estimated cost of Plan SH-3 is \$3.74 million compared to Plan SH-4 estimated costs of \$3.6 million. These costs are itemized in Tables E-37 and E-38, respectively.

Nonstructural Plan SH-5 was developed to protect against the 25-year tidal event. This plan required no residential alterations and a minimum of commercial protection. The costs of this plan, as shown in Table E-39, approximated \$0.3 million dollars. Plan SH-6 was also nonstructural and the April 1980 costs of \$0.5 million reflect protection against the 70-year event. Acquisition and demolition of two structures, raising of two structures, floodproofing, and 1,600 feet of floodwall construction are elements of this plan. Estimated costs of Plan SH-6 are presented in Table E-40. Nonstructural Plan SH-7 was designed to protect against the 220-year tidal event. The cost of this plan, in April 1980 dollars, was estimated to be \$1.21 million. With the exception of the acquisition and demolition of three residences, Plan SH-7 is oriented entirely toward the commercial sector. Indeed, 95 percent of the plan costs are for protection of the commercial sector. Itemized costs of Plan SH-7 are presented in Table E-41. Estimated annual costs of Plans SH-1 through SH-7 are shown in Table E-42.

TABLE E-35

SNOW HILL COST SUMMARY
FOR STRUCTURAL PLAN SH-1
(70-Year Event, 9 Foot Elevation)
- April 1980 Costs -

DESCRIPTION	QUANTITY	UNIT	UNIT COST	COST	
				FEDERAL	NON-FED
Lands					
Levee	1.1	AC	\$ 10,000	\$ 0	\$ 11,000
Wall	3.8	AC	15,000	0	57,000
Sub-total				0	68,000
Contingencies			20%	0	13,600
Relocations (None)					
Levee (1,510 FT.)					
Stripping	1,600	C.Y.	2.70	4,320	0
Trenching	9,600	C.Y.	2.70	25,920	0
Tot. Embankment	12,900	C.Y.	7.50	96,750	0
Riprap	—	C.Y.	—	—	—
Seed & Sod	3,700	S.Y.	0.45	1,665	0
Clearing	—	JOB	L.S.	5,000	0
Closure Structure	—	—	—	—	—
Floodwall (5,680 FT.)					
Concrete	6,200	C.Y.	200.00	1,240,000	0
Steel	714,700	LB.	0.50	357,350	0
Fill	13,700	C.Y.	3.00	41,100	0
Seed & Sod	109,700	S.Y.	0.45	49,365	0
Excavation	13,200	C.Y.	2.50	33,000	0
Stripping	5,200	C.Y.	2.50	13,000	0
Clearing	—	JOB	L.S.	5,000	0
Closure Structure	—	JOB	L.S.	5,000	0
Sub-total				1,877,470	0
Contingencies			30%	563,530	0
Sub-total				2,441,000	0
E&D			15%	366,150	0
S&A			5%	122,050	0
Sub-total				\$2,929,200	\$81,600
Total Cost	(April 1980)			\$3,010,800	

AC - acre
C.Y. - cubic yard
LB. - pound
S.Y. - square yard
L.S. - lump sum

TABLE E-36

SNOW HILL COST SUMMARY
FOR STRUCTURAL PLAN SH-2
(70-Year Event, 9 Foot Elevation)
- April 1980 Costs -

<u>DESCRIPTION</u>	<u>QUANTITY</u>	<u>UNIT</u>	<u>UNIT COST</u>	<u>COST</u>	
				<u>FEDERAL</u>	<u>NON-FED</u>
Lands					
Levee	0.3	AC	\$ 10,000	\$ 0	\$ 3,000
Wall	3.7	AC	15,000	0	55,500
Sub-total				0	58,500
Contingencies			20%	0	11,700
Relocations (None)					
Levee (400 FT.)					
Stripping	400	C.Y.	2.70	1,080	0
Trenching	2,500	C.Y.	2.70	6,750	0
Tot. Embankment	3,400	C.Y.	7.50	25,500	0
Riprap	—	C.Y.	—	—	—
Seed & Sod	1,000	S.Y.	0.45	450	0
Clearing	—	JOB	L.S.	2,000	0
Closure Structure	—	—	—	—	—
Floodwall (5,680 FT.)					
Concrete	6,200	C.Y.	200.00	1,240,000	0
Steel	714,700	LB.	0.50	357,350	0
Fill	13,700	C.Y.	3.00	41,100	0
Seed & Sod	109,700	S.Y.	0.45	49,365	0
Excavation	12,700	C.Y.	2.50	31,750	0
Stripping	5,200	C.Y.	2.50	13,000	0
Clearing	—	JOB	L.S.	5,000	0
Closure Structure	—	JOB	L.S.	5,000	0
Sub-total				1,778,345	0
Contingencies			30%	533,655	0
Sub-total				2,312,000	0
E&D			15%	346,800	0
S&A			5%	115,600	0
Sub-total				<u>\$2,774,400</u>	<u>\$70,200</u>
Total Cost	(April 1980)			\$2,844,600	

AC - acre
C.Y. - cubic yard
LB. - pound
S.Y. - square yard
L.S. - lump sum

TABLE E-37

SNOW HILL COST SUMMARY
FOR STRUCTURAL PLAN SH-3
(500-Year Event, 11 Foot Elevation)
- April 1980 Costs -

DESCRIPTION	QUANTITY	UNIT	UNIT COST	COST	
				FEDERAL	NON-FED
Lands					
Levee	1.8	AC	\$ 10,000	\$ 0	\$ 18,000
Wall	4.0	AC	15,000	0	60,000
Sub-total				0	78,000
Contingencies			20%	0	15,600
Relocations (None)					
Levee (2,080 FT.)					
Stripping	2,700	C.Y.	2.50	6,750	0
Trenching	13,200	C.Y.	2.50	33,000	0
Tot. Embankment	21,000	C.Y.	7.00	147,000	0
Riprap	—	C.Y.	—	—	—
Seed & Sod	6,000	S.Y.	0.45	2,700	0
Clearing	—	JOB	L.S.	6,000	0
Closure Structure	—	—	—	—	—
Floodwall (5,840 FT.)					
Concrete	7,600	C.Y.	200.00	1,520,000	0
Steel	872,100	LB.	0.50	436,050	0
Fill	15,200	C.Y.	3.00	45,600	0
Seed & Sod	122,500	S.Y.	0.45	55,125	0
Excavation	14,700	C.Y.	2.50	36,750	0
Stripping	5,900	C.Y.	2.50	14,750	0
Clearing	—	JOB	L.S.	5,000	0
Closure Structure	—	JOB	L.S.	30,000	0
Sub-total				2,338,725	0
Contingencies			30%	701,275	0
Sub-total				3,040,000	0
E&D			15%	456,000	0
S&A			5%	152,000	0
Sub-total				\$3,648,000	\$93,600
Total Cost	(April 1980)			\$ 3,741,600	

AC - acre
C.Y. - cubic yard
LB. - pound
S.Y. - square yard
L.S. - lump sum

TABLE E-38

SNOW HILL COST SUMMARY
FOR STRUCTURAL PLAN SH-4
(500-Year Event, 11 Foot Elevation)
- April 1980 Costs -

DESCRIPTION	QUANTITY	UNIT	UNIT COST	COST	
				FEDERAL	NON-FED
Lands					
Levee	0.5	AC	\$ 10,000	\$ 0	\$ 5,000
Wall	4.2	AC	15,000	0	63,000
Sub-total				0	68,000
Contingencies			20%	0	13,600
Relocations (None)					
Levee (620 FT.)					
Stripping	800	C.Y.	2.70	2,160	0
Trenching	3,900	C.Y.	2.70	10,530	0
Tot. Embankment	6,100	C.Y.	7.50	45,750	0
Riprap	400	C.Y.	110.00	44,000	0
Seed & Sod	1,500	S.Y.	0.45	675	0
Clearing	—	JOB	L.S.	6,000	0
Closure Structure	—	—	—	—	—
Floodwall (5,840 FT.)					
Concrete	7,600	C.Y.	200.00	1,520,000	0
Steel	872,100	LB.	0.50	436,050	0
Fill	15,200	C.Y.	3.00	45,600	0
Seed & Sod	122,500	S.Y.	0.45	55,125	0
Excavation	14,700	C.Y.	2.50	36,750	0
Stripping	5,900	C.Y.	2.50	14,750	0
Clearing	—	JOB	L.S.	5,000	0
Closure Structure	—	JOB	L.S.	30,000	0
Sub-total				2,252,390	0
Contingencies			30%	675,610	0
Sub-total				2,928,000	0
E&D			15%	439,500	0
S&A			5%	146,500	0
Sub-total				\$3,514,000	\$81,600
Total Cost	(April 1980)			\$3,595,600	

AC - acre
C.Y. - cubic yard
LB. - pound
S.Y. - square yard
L.S. - lump sum

TABLE E-39

SNOW HILL COST SUMMARY
 FOR NONSTRUCTURAL PLAN SH-5
 (25-Year Event)
 - April 1980 Costs -

<u>DESCRIPTION</u>	<u>COST</u>
<u>Residential</u>	
Utility Additions	
<u>0</u> Units	\$ 0
Raising	
<u>0</u> Homes 1'-4"	0
<u>0</u> Homes 2'-8"	0
<u>0</u> Homes 4'-0"	0
Relocations	
<u>0</u> Homes	0
<u>0</u> Trailers	0
Acquisition & Demolition	
<u>0</u> Homes	0
	Sub-total 0
	Contingencies @ 20% 0
	E&D, S&A @ 1% 0
	Total \$ 0
<u>Commercial</u>	
Acquisition & Demolition	
<u>0</u> Structures	\$ 0
Raising	
<u>1</u> Structure 1'-4"	9,800
<u>0</u> Structures 2'-8"	0
<u>0</u> Structures 4'-0"	0
Relocations	
<u>0</u> Structures	0
Floodproofing	
<u>2</u> Structures	8,700
Floodwall	
1,760' Length for 4 Structures	176,000
	Sub-total 194,500
	Contingencies @ 30% 58,400
	E&D @ 15% 37,950
	S&A @ 5% 12,650
	Total \$ 303,500
Total Cost (April 1980)	\$ 303,500

TABLE E-40

SNOW HILL COST SUMMARY
FOR NONSTRUCTURAL PLAN SH-6
(70-Year Event)
- April 1980 Costs -

<u>DESCRIPTION</u>	<u>COST</u>
<u>Residential</u>	
Utility Additions	
<u>0</u> Units	\$ 0
Raising	
<u>0</u> Homes 1'-4"	0
<u>0</u> Homes 2'-8"	0
<u>0</u> Homes 4'-0"	0
Relocations	
<u>0</u> Homes	0
<u>0</u> Trailers	0
Acquisition & Demolition	
<u>1</u> Home	17,000
	<u>17,000</u>
Sub-total	17,000
Contingencies @ 20%	3,400
	<u>20,400</u>
E&D, S&A @ 1%	200
Total	\$ <u>20,600</u>
<u>Commercial</u>	
Acquisition & Demolition	
<u>1</u> Structure	\$ 16,100
Raising	
<u>0</u> Structures 1'-4"	0
<u>2</u> Structures 2'-8"	19,300
<u>0</u> Structures 4'-0"	0
Relocations	
<u>0</u> Structures	0
Floodproofing	
<u>5</u> Structures	40,500
Floodwall	
1,630' Length for 3 Structures	245,000
	<u>320,900</u>
Sub-total	320,900
Contingencies @ 30%	96,300
	<u>417,200</u>
E&D @ 15%	62,550
S&A @ 5%	20,850
Total	\$ <u>500,600</u>
Total Cost (April 1980)	\$ 521,200

TABLE E-41

SNOW HILL COST SUMMARY
FOR NONSTRUCTURAL PLAN SH-7
(220-Year Event)
- April 1980 Costs -

<u>DESCRIPTION</u>	<u>COST</u>
<u>Residential</u>	
Utility Additions	
<u>0</u> Units	\$ 0
Raising	
<u>0</u> Homes 1'-4"	0
<u>0</u> Homes 2'-8"	0
<u>0</u> Homes 4'-0"	0
Relocations	
<u>0</u> Homes	0
<u>0</u> Trailers	0
Acquisition & Demolition	
<u>3</u> Homes	50,400
	<u>50,400</u>
Sub-total	50,400
Contingencies @ 20%	10,100
	<u>60,500</u>
E&D, S&A @ 1%	600
Total	<u>\$ 61,100</u>
<u>Commercial</u>	
Acquisition & Demolition	
<u>5</u> Structures	\$ 253,000
Raising	
<u>0</u> Structures 1'-4"	0
<u>1</u> Structure 2'-8"	8,500
<u>0</u> Structures 4'-0"	0
Relocations	
<u>0</u> Structures	0
Floodproofing	
<u>5</u> Structures	125,400
Floodwall	
1,950' Length for 3 Structures	349,700
	<u>736,600</u>
Sub-total	736,600
Contingencies @ 30%	221,000
	<u>957,600</u>
E&D @ 15%	143,625
S&A @ 5%	47,875
Total	<u>\$ 1,149,100</u>
 Total Cost (April 1980)	 <u>\$ 1,210,200</u>

TABLE E-42
 SNOW HILL FLOOD CONTROL ALTERNATIVES:
 ESTIMATES OF ANNUAL EQUIVALENT CHARGES
 - April 1980 Costs -

<u>Plan</u>	<u>First Cost</u>	<u>Interest & Amortization Factor*</u>	<u>Interest & Amortization</u>	<u>Operation & ** Maintenance Costs</u>	<u>Total Annual Equivalent Charges</u>
SH-1	\$ 3,010,800	0.07132	\$ 214,700	\$ 18,800	\$ 233,500
SH-2	2,844,600	0.07132	202,900	17,800	220,700
SH-3	3,741,600	0.07132	266,900	23,400	290,300
SH-4	3,595,600	0.07132	256,400	22,500	278,900
SH-5	303,500	0.07361	22,300	0	22,300
SH-6	521,200	0.07361	38,400	0	38,400
SH-7	\$ 1,210,200	0.07361	\$ 89,100	\$ 0	\$ 89,100

*The Interest and Amortization Factor is based on an economic life of 100 years for structural projects (50 years for nonstructural projects) and a Federal interest rate of 7 1/8 percent (FY 1980).

** Estimates of operation and maintenance costs were based on one percent of the construction costs.

ST. MICHAELS

Four tidal flood protection plans were developed for the community of St. Michaels, Maryland. Two structural plans protected against the 100-year and 450-year event while the two nonstructural plans protected against the 45-year event and the 100-year event. Structural Plan SM-1 consisted of 2,600 feet of levee construction and 11,400 feet of floodwall construction. With a top elevation of 10 feet, this plan protected against the 100-year event at a cost of \$7.2 million in April 1980 dollars. Structural Plan SM-2 also included levee construction (8,700 feet) and floodwall construction (15,200 feet). However, Plan SM-2 was designed to a top elevation of 12 feet. This plan design protected against the 450-year event at an estimated April 1980 cost of \$11.98 million. Estimated plan costs are presented in Tables E-43 and E-44 for plans SM-1 and SM-2, respectively.

Nonstructural Plan SM-3 included four utility room additions, demolition of one structure, floodproofing of one structure, and construction of 2,500 feet of floodwall. Designed to protect against the 45-year flood event, this plan was estimated to cost \$0.73 million in April 1980 dollars. Plan SM-4 is similar to Plan SM-3; however, Plan SM-4 increased the residential structures affected to seven (five additions, 2 raisings) and increased the commercial floodproofing measures and floodwall heights. This plan protected against the 100-year event at an estimated April 1980 cost of \$0.92 million. Costs of Plans SM-3 and SM-4 are listed in Tables E-45 and E-46, respectively, while Table E-47 presents estimates of annual costs for plans SM-1 through SM-4.

TABLE E-43

ST. MICHAELS COST SUMMARY
 FOR STRUCTURAL PLAN SM-1
 (100-Year Event, 10 Foot Elevation)
 - April 1980 Costs -

DESCRIPTION	QUANTITY	UNIT	UNIT COST	COST	
				FEDERAL	NON-FED
Lands					
Levee	2.8	AC	\$ 20,000	\$ 0	\$ 56,000
Wall	7.7	AC	30,000	0	231,000
Sub-total				0	287,000
Contingencies			20%	0	57,400
Relocations (None)					
Levee (2,590 FT.)					
Stripping	4,200	C.Y.	2.50	10,500	0
Trenching	16,400	C.Y.	2.50	41,000	0
Tot. Embankment	33,500	C.Y.	7.00	234,500	0
Riprap	—	C.Y.	—	—	—
Seed & Sod	8,800	S.Y.	0.45	3,960	0
Clearing	—	JOB	L.S.	2,000	0
Closure Structure	—	—	—	—	—
Floodwall (11,395 FT.)					
Concrete	14,800	C.Y.	200.00	2,960,000	0
Steel	1,690,300	LB.	0.50	845,150	0
Fill	29,600	C.Y.	3.00	88,800	0
Seed & Sod	238,300	S.Y.	0.45	107,235	0
Excavation	28,600	C.Y.	2.20	62,920	0
Stripping	11,500	C.Y.	2.50	28,750	0
Clearing	—	JOB	L.S.	25,000	0
Closure Structure	—	—	—	—	—
Sub-total				4,409,815	0
Contingencies			30%	1,323,185	0
Sub-total				5,733,000	0
E&D			15%	859,950	0
S&A			5%	286,650	0
Sub-total				\$6,879,600	\$344,400
Total Cost	(April 1980)				\$ 7,224,000

AC - acre
 C.Y. - cubic yard
 LB. - pound
 S.Y. - square yard
 L.S. - lump sum

TABLE E-44

ST. MICHAELS COST SUMMARY
 FOR STRUCTURAL PLAN SM-2
 (450-Year Event, 12 Foot Elevation)
 - April 1980 Costs -

DESCRIPTION	QUANTITY	UNIT	UNIT COST	COST	
				FEDERAL	NON-FED
Lands					
Levee	9.4	AC	\$20,000	\$ 0	\$188,000
Wall	10.7	AC	30,000	0	321,000
Sub-total				0	509,000
Contingencies			20%	0	101,800
Relocations (None)					
Levee (8,690 FT.)					
Stripping	13,800	C.Y.	2.20	30,360	0
Trenching	55,000	C.Y.	2.40	132,000	0
Tot. Embankment	106,400	C.Y.	7.00	744,800	0
Riprap	—	C.Y.	—	—	—
Seed & Sod	29,000	S.Y.	0.45	13,050	0
Clearing	—	JOB	L.S.	20,000	0
Closure Structure	—	JOB	L.S.	200,000	0
Floodwall (15,200 FT.)					
Concrete	22,200	C.Y.	200.00	4,440,000	0
Steel	2,547,300	LB.	0.50	1,273,650	0
Fill	41,800	C.Y.	3.00	125,400	0
Seed & Sod	338,600	S.Y.	0.45	152,370	0
Excavation	40,400	C.Y.	2.20	88,880	0
Stripping	16,500	C.Y.	2.20	36,300	0
Clearing	—	JOB	L.S.	25,000	0
Closure Structure	—	—	—	—	—
Sub-total				7,281,810	0
Contingencies			30%	2,184,190	0
Sub-total				9,466,000	0
E&D			15%	1,420,500	0
S&A			5%	473,500	0
Sub-total				\$ 11,360,000	\$610,800
Total Cost	(April 1980)			\$11,970,800	

AC - acre
 C.Y. - cubic yard
 LB. - pound
 S.Y. - square yard
 L.S. - lump sum

TABLE E-45

ST. MICHAELS COST SUMMARY
 FOR NONSTRUCTURAL PLAN SM-3
 (45-Year Event)
 - April 1980 Costs -

<u>DESCRIPTION</u>	<u>COST</u>
<u>Residential</u>	
Utility Additions	
<u>4</u> Units	\$ 29,600
Raising	
<u>0</u> Homes 1'-4"	0
<u>0</u> Homes 2'-8"	0
<u>0</u> Homes 4'-0"	0
Relocations	
<u>0</u> Homes	0
<u>0</u> Trailers	0
Acquisition & Demolition	
<u>0</u> Homes	0
	Sub-total
	29,600
	Contingencies @ 20%
	5,900
	35,500
	E&D, S&A @ 1%
	400
	Total
	\$ 35,900
<u>Commercial</u>	
Acquisition & Demolition	
<u>1</u> Structure	\$ 73,000
Raising	
<u>0</u> Structures 1'-4"	0
<u>0</u> Structures 2'-8"	0
<u>0</u> Structures 4'-0"	0
Relocations	
<u>0</u> Structures	0
Floodproofing	
<u>1</u> Structure	23,900
Floodwall	
2,500' Length for 5 Structures	348,000
	Sub-total
	444,900
	Contingencies @ 30%
	133,500
	578,400
	E&D @ 15%
	86,800
	S&A @ 5%
	28,900
	Total
	\$ 694,100
 Total Cost (April 1980)	 \$730,000

TABLE E-46

ST. MICHAELS COST SUMMARY
FOR NONSTRUCTURAL PLAN SM-4
(100-Year Event)
- April 1980 Costs -

<u>DESCRIPTION</u>	<u>COST</u>
<u>Residential</u>	
Utility Additions	
<u>5</u> Units	\$ 37,000
Raising	
<u>2</u> Homes 1'-4"	19,600
<u>0</u> Homes 2'-8"	0
<u>0</u> Homes 4'-0"	0
Relocations	
<u>0</u> Homes	0
<u>0</u> Trailers	0
Acquisition & Demolition	
<u>0</u> Homes	0
	<u>56,600</u>
Sub-total	56,600
Contingencies @ 20%	<u>11,300</u>
	67,900
E&D, S&A @ 1%	700
Total	\$ 68,600
<u>Commercial</u>	
Acquisition & Demolition	
<u>1</u> Structure	\$ 73,000
Raising	
<u>0</u> Structures 1'-4"	0
<u>0</u> Structures 2'-8"	0
<u>0</u> Structures 4'-0"	0
Relocations	
<u>0</u> Structures	0
Floodproofing	
<u>1</u> Structure	27,500
Floodwall	
2,500' Length for 5 Structures	<u>442,900</u>
	543,400
Sub-total	543,400
Contingencies @ 30%	<u>163,000</u>
	706,400
E&D @ 15%	106,000
S&A @ 5%	<u>35,300</u>
Total	\$ 847,700
 Total Cost (April 1980)	 \$916,300

TABLE E-47

ST. MICHAELS FLOOD CONTROL ALTERNATIVES:
ESTIMATES OF ANNUAL EQUIVALENT CHARGES
- April 1980 Costs -

<u>Plan</u>	<u>First Cost</u>	<u>Interest & Amortization Factor*</u>	<u>Interest & Amortization</u>	<u>Operation & ** Maintenance Costs</u>	<u>Total Annual Equivalent Charges</u>
SM-1	\$ 7,224,000	0.07132	\$ 515,200	\$ 44,100	\$ 559,300
SM-2	11,970,800	0.07132	853,800	72,800	926,600
SM-3	730,000	0.07361	53,700	0	53,700
SM-4	\$ 916,300	0.07361	\$ 67,400	\$ 0	\$ 67,400

* The Interest and Amortization Factor is based on an economic life of 100 years for structural projects (50 years for nonstructural projects) and a Federal interest rate of 7 1/8 percent (FY 1980).

** Estimates of operation and maintenance costs were based on one percent of the construction costs.

TILGHMAN ISLAND

A total of seven tidal flood protection plans were developed for the analysis of Tilghman Island, Maryland. Four structural plans considered levee and floodwall construction for protection against the 90-year event and the approximate 500-year event. Structural Plan TI-1 was designed to protect against the 90-year tidal flood event. This was based on 7,500 feet of levee construction and 10,050 feet of floodwall construction to a top elevation of nine feet. The estimated April 1980 cost of this plan was \$7.37 million. Also designed to protect against the 90-year flood event, Structural Plan TI-2 included 1,250 feet of levee construction and 4,100 feet of floodwall construction with a top height of nine feet. This plan was less expensive than plan TI-1 and cost \$2.34 million in April 1980 dollars. Tables E-48 and E-49 reflect the itemized costs of these two plans.

Structural Plan TI-3 is an expanded version of Plan TI-1. The length of levee and floodwall construction is the same in both plans but Plan TI-3 was designed to a top elevation of 11 feet. This allowed for protection against the approximate 500-year event. Cost of this plan in April 1980 dollars was estimated to be \$8.90 million. Structural Plan TI-4 also was developed to protect against tidal floods which approximate the 500-year event. This plan is a modified version of Plan TI-2. The levee and floodwall lengths are the same as in Plan TI-2, (1,250 feet and 4,100 feet, respectively) but the top elevation of 11 feet is two feet higher than the Plan TI-2 height. Cost of this plan was estimated to be \$2.88 million in April 1980 dollars. Costs of Plans TI-3 and TI-4 are listed in Tables E-50 and E-51.

The three nonstructural tidal flood control plans for Tilghman Island range in cost from \$0.12 million to \$2.77 million in April 1980 dollars. Nonstructural Plan TI-5 included three trailer relocations, demolition of one house and 520 feet of floodwall construction. Designed to protect against the 15-year event, this plan was estimated to cost \$0.12 million as shown in Table E-52. Plan TI-6 included raising of 7 structures, relocation of 6 structures, floodproofing of one structure, demolition of 12 structures and construction of 910 feet of floodwall. Estimated to cost \$1.04 million, as shown in Table E-53, this plan was developed to protect against the 40-year tidal flood. The 90-year flood event was the level of protection for which plan TI-7 was designed. The majority of the plan costs were oriented toward the relocation, raising, and demolition of residential structures. The biggest commercial cost item was the construction of more than 1,500 feet of floodwall to protect 6 commercial structures. Costs of this plan are shown in Table E-54 and were estimated to be \$2.77 million in April 1980 dollars. Estimates of annual costs for all the plans examined for protection of Tilghman Island are found in Table E-55.

TABLE E-48

TILGHMAN ISLAND COST SUMMARY
FOR STRUCTURAL PLAN TI-1
(90-Year Event, 9 Foot Elevation)
- April 1980 Costs -

DESCRIPTION	QUANTITY	UNIT	UNIT COST	COST	
				FEDERAL	NON-FED
Lands					
Levee	7.7	AC	\$20,000	\$ 0	\$154,000
Wall	6.6	AC	15,000	0	99,000
Sub-total				0	253,000
Contingencies			20%	0	50,600
Relocations	1	JOB	L.S.	31,000	0
Levee (7,510 FT.)					
Stripping	11,400	C.Y.	2.50	28,500	0
Trenching	48,000	C.Y.	2.20	105,600	0
Tot. Embankment	85,400	C.Y.	7.00	597,000	0
Riprap	5,000	C.Y.	73.00	365,000	0
Seed & Sod	23,000	S.Y.	0.45	10,350	0
Clearing	—	JOB	L.S.	10,000	0
Closure Structure	—	JOB	L.S.	30,000	0
Floodwall (10,050 FT.)					
Concrete	12,000	C.Y.	200.00	2,400,000	0
Steel	1,370,000	LB.	0.50	685,000	0
Fill	25,200	C.Y.	3.00	75,600	0
Seed & Sod	202,000	S.Y.	0.45	90,900	0
Excavation	24,300	C.Y.	2.20	53,400	0
Stripping	9,700	C.Y.	2.50	24,250	0
Clearing	—	—	—	—	—
Closure Structure	—	JOB	L.S.	23,000	0
Sub-total				4,529,600	0
Contingencies			30%	1,358,900	0
Sub-total				5,888,500	0
E&D			15%	883,300	0
S&A			5%	294,400	0
Sub-total				\$ 7,066,200	\$303,600
Total Cost	(April 1980)			\$ 7,369,800	

AC - acre
C.Y. - cubic yard
LB. - pound
S.Y. - square yard
L.S. - lump sum

TABLE E-49

TILGHMAN ISLAND COST SUMMARY
FOR STRUCTURAL PLAN TI-2
(90-Year Event, 9 Foot Elevation)
- April 1980 Costs -

DESCRIPTION	QUANTITY	UNIT	UNIT COST	COST	
				FEDERAL	NON-FED
Lands					
Levee	0.7	AC	\$15,000	\$ 0	\$10,500
Wall	2.7	AC	20,000	0	54,000
Sub-total				0	64,500
Contingencies			20%	0	12,900
Relocations (None)					
Levee (1,250 FT.)					
Stripping	1,000	C.Y.	2.50	2,500	0
Trenching	3,500	C.Y.	2.20	7,700	0
Tot. Embankment	5,200	C.Y.	7.00	36,400	0
Riprap	—	C.Y.	—	—	—
Seed & Sod	2,600	S.Y.	0.45	1,170	0
Clearing	—	—	—	—	—
Closure Structure	—	—	—	—	—
Floodwall (4,100 FT.)					
Concrete	4,900	C.Y.	200.00	980,000	0
Steel	559,000	LB.	0.50	279,500	0
Fill	10,300	C.Y.	3.00	30,900	0
Seed & Sod	82,200	S.Y.	0.45	36,990	0
Excavation	9,900	C.Y.	2.20	21,780	0
Stripping	4,000	C.Y.	2.50	10,000	0
Clearing	—	—	—	—	—
Closure Structure	—	JOB	L.S.	45,000	0
Sub-total				1,451,940	0
Contingencies			30%	435,060	0
Sub-total				1,887,000	0
E&D			15%	283,500	0
S&A			5%	94,500	0
Sub-total				\$ 2,265,000	\$77,400
Total Cost	(April 1980)			\$ 2,342,400	

AC - acre
C.Y. - cubic yard
LB. - pound
S.Y. - square yard
L.S. - lump sum

TABLE E-50

TILGHMAN ISLAND COST SUMMARY
FOR STRUCTURAL PLAN TI-3
(500-Year Event, 11 Foot Elevation)
- April 1980 Costs -

DESCRIPTION	QUANTITY	UNIT	UNIT COST	COST	
				FEDERAL	NON-FED
Lands					
Levee	9.8	AC	\$15,000	\$ 0	\$147,000
Wall	7.0	AC	20,000	0	140,000
Sub-total				0	287,000
Contingencies			20%	0	57,400
Relocations	1	JOB	L.S.	31,000	0
Levee (7,510 FT.)					
Stripping	14,700	C.Y.	2.50	36,750	0
Trenching	47,600	C.Y.	2.20	104,720	0
Tot. Embankment	111,300	C.Y.	7.00	779,100	0
Riprap	7,000	C.Y.	73.00	511,000	0
Seed & Sod	28,100	S.Y.	0.45	12,645	0
Clearing	—	JOB	L.S.	10,000	0
Closure Structure	—	JOB	L.S.	45,000	0
Floodwall (10,050 FT.)					
Concrete	14,200	C.Y.	200.00	2,840,000	0
Steel	1,623,600	LB.	0.50	811,800	0
Fill	27,200	C.Y.	3.00	81,600	0
Seed & Sod	219,600	S.Y.	0.45	98,820	0
Excavation	26,300	C.Y.	2.20	57,860	0
Stripping	10,700	C.Y.	2.50	26,750	0
Clearing	—	—	—	—	—
Closure Structure	—	JOB	L.S.	35,000	0
Sub-total				5,482,045	0
Contingencies			30%	1,644,614	0
Sub-total				7,126,660	0
E&D			15%	1,069,000	0
S&A			5%	356,300	0
Sub-total				\$ 8,551,960	\$344,400
Total Cost	(April 1980)			\$ 8,896,360	

AC - acre
C.Y. - cubic yard
LB. - pound
S.Y. - square yard
L.S. - lump sum

TABLE E-51

TILGHMAN ISLAND COST SUMMARY
FOR STRUCTURAL PLAN TI-4
(500-Year Event, 11 Foot Elevation)
- April 1980 Costs -

<u>DESCRIPTION</u>	<u>QUANTITY</u>	<u>UNIT</u>	<u>UNIT COST</u>	<u>COST</u>	
				<u>FEDERAL</u>	<u>NON-FED</u>
Lands					
Levee	1.1	AC	\$15,000	\$ 0	\$16,500
Wall	2.9	AC	20,000	0	58,000
Sub-total				0	74,500
Contingencies			20%	0	14,900
Relocations (None)					
Levee (1,250 FT.)					
Stripping	1,600	C.Y.	2.50	4,000	0
Trenching	8,000	C.Y.	2.20	17,600	0
Tot. Embankment	12,200	C.Y.	7.00	85,400	0
Riprap	—	C.Y.	—	—	—
Seed & Sod	3,600	S.Y.	0.45	1,620	0
Clearing	—	—	—	—	—
Closure Structure	—	—	—	—	—
Floodwall (4,100 FT.)					
Concrete	5,800	C.Y.	200.00	1,160,000	0
Steel	62,400	LB.	0.50	331,200	0
Fill	11,100	C.Y.	3.00	33,300	0
Seed & Sod	89,600	S.Y.	0.45	40,320	0
Excavation	10,700	C.Y.	2.20	23,540	0
Stripping	4,400	C.Y.	2.50	11,000	0
Clearing	—	—	—	—	—
Closure Structure	—	JOB	L.S.	80,000	0
Sub-total				1,787,980	0
Contingencies			30%	536,020	0
Sub-total				2,324,000	0
E&D			15%	348,600	0
S&A			5%	116,200	0
Sub-total				<u>\$ 2,788,800</u>	<u>\$89,400</u>
Total Cost	(April 1980)			\$ 2,878,200	

AC - acre
C.Y. - cubic yard
LB. - pound
S.Y. - square yard
L.S. - lump sum

TABLE E-52

TILGHMAN ISLAND COST SUMMARY
FOR NONSTRUCTURAL PLAN TI-5
(15-Year Event)
- April 1980 Costs -

<u>DESCRIPTION</u>	<u>COST</u>
<u>Residential</u>	
Utility Additions	\$ 0
<u>0</u> Units	
Raising	
<u>0</u> Homes 1'-4"	0
<u>0</u> Homes 2'-8"	0
<u>0</u> Homes 4'-0"	0
Relocations	
<u>0</u> Homes	0
<u>3</u> Trailers @ \$8,000 ea.	24,000
Acquisition & Demolition	
<u>1</u> Home @ \$8,500	8,500
	Sub-total <u>32,500</u>
	Contingencies @ 20% <u>6,500</u>
	<u>39,000</u>
	E&D, S&A @ 1% <u>400</u>
	Total \$ <u>39,400</u>
<u>Commercial</u>	
Acquisition & Demolition	
<u>0</u> Structures	\$ 0
Raising	
<u>0</u> Structures 1'-4"	0
<u>0</u> Structures 2'-8"	0
<u>0</u> Structures 4'-0"	0
Relocations	
<u>0</u> Structures	0
Floodproofing	
<u>0</u> Structures	0
Floodwall	
520' Length for 2 Structures	52,000
	Sub-total <u>52,000</u>
	Contingencies @ 30% <u>15,600</u>
	<u>67,600</u>
	E&D @ 15% <u>10,100</u>
	S&A @ 5% <u>3,400</u>
	Total \$ <u>81,100</u>
Total Cost (April 1980)	\$120,500

TABLE E-53

TILGHMAN ISLAND COST SUMMARY
FOR NONSTRUCTURAL PLAN TI-6
(40-Year Event)
- April 1980 Costs -

<u>DESCRIPTION</u>	<u>COST</u>
<u>Residential</u>	
Utility Additions	
<u>0</u> Units	\$ 0
Raising	
<u>5</u> Homes 1'-4"	44,800
<u>0</u> Homes 2'-8"	0
<u>0</u> Homes 4'-0"	0
Relocations	
<u>1</u> Home	31,000
<u>5</u> Trailers	40,000
Acquisition & Demolition	
<u>12</u> Homes	563,500
	<u>679,300</u>
Sub-total	679,300
Contingencies @ 20%	135,900
	<u>815,200</u>
E&D, S&A @ 1%	8,200
Total	<u>\$ 823,400</u>
 <u>Commercial</u>	
Acquisition & Demolition	
<u>0</u> Structures	\$ 0
Raising	
<u>2</u> Structures 1'-4"	17,500
<u>0</u> Structures 2'-8"	0
<u>0</u> Structures 4'-0"	0
Relocations	
<u>0</u> Structures	0
Floodproofing	
<u>1</u> Structure	4,650
Floodwall	
910' Length for 4 Structures	115,500
	<u>137,650</u>
Sub-total	137,650
Contingencies @ 30%	41,300
	<u>178,950</u>
E&D @ 15%	26,850
S&A @ 5%	8,950
Total	<u>\$ 214,750</u>
 Total Cost (April 1980)	 <u>\$1,038,150</u>

TABLE E-54

TILGHMAN ISLAND COST SUMMARY
FOR NONSTRUCTURAL PLAN TI-7
(90-Year Event)
-April 1980 Costs-

<u>DESCRIPTION</u>	<u>COST</u>
<u>Residential</u>	
Utility Additions	
<u>0</u> Units	\$ 0
Raising	
<u>7</u> Homes 1'-4"	66,500
<u>5</u> Homes 2'-8"	49,400
<u>0</u> Homes 4'-0"	0
Relocations	
<u>1</u> Home	31,000
<u>8</u> Trailers	64,000
Acquisition & Demolition	
<u>27</u> Homes	1,267,000
	Sub-total <u>1,477,900</u>
	Contingencies @ 20% <u>295,600</u>
	<u>1,773,500</u>
	E&D, S&A @ 1% <u>17,700</u>
	Total \$ <u>1,790,600</u>
<u>Commercial</u>	
Acquisition & Demolition	
<u>2</u> Structures	\$ 390,000
Raising	
<u>0</u> Structures 1'-4"	0
<u>2</u> Structures 2'-8"	19,300
<u>0</u> Structures 4'-0"	0
Relocations	
<u>0</u> Structures	0
Floodproofing	
<u>1</u> Structure	4,700
Floodwall	
1,560' Length for 6 Structures	215,150
	Sub-total <u>629,150</u>
	Contingencies @ 30% <u>188,750</u>
	<u>817,900</u>
	E&D @ 15% <u>122,700</u>
	S&A @ 5% <u>40,900</u>
	Total \$ <u>981,500</u>
Total Cost (April 1980)	<u>\$2,772,100</u>

TABLE E-55

TILGHMAN ISLAND FLOOD CONTROL ALTERNATIVES:
ESTIMATES OF ANNUAL EQUIVALENT CHARGES
- April 1980 Costs -

<u>Plan</u>	<u>First Cost</u>	<u>Interest & Amortization Factor*</u>	<u>Interest & Amortization</u>	<u>Operation & ** Maintenance Costs</u>	<u>Total Annual Equivalent Charges</u>
TI-1	\$ 7,369,800	0.07132	\$ 525,600	\$ 45,300	\$ 570,900
TI-2	2,342,400	0.07132	167,100	14,500	181,600
TI-3	8,896,360	0.07132	634,500	54,800	689,300
TI-4	2,878,200	0.07132	205,300	17,900	223,200
TI-5	120,500	0.07361	8,900	0	8,900
TI-6	1,038,150	0.07361	76,400	0	76,400
TI-7	\$ 2,772,100	0.07361	\$ 204,100	\$ 0	\$ 204,100

* The Interest and Amortization Factor is based on an economic life of 100 years for structural projects (50 years for nonstructural projects) and a Federal interest rate of 7 1/8 percent (FY 1980).

** Estimates of operation and maintenance costs were based on one percent of the construction costs.

VIRGINIA COMMUNITIES

The Norfolk District developed cost estimates for both structural and nonstructural flood control alternatives for each of the five communities examined. Costs for structural alternatives were initially developed to reflect July 1979 price levels. However, with the reanalysis conducted in 1983, costs were updated to reflect January 1983 price levels.

Estimates of annual equivalent costs were also updated. They were computed using an interest rate of 7-7/8 percent (Fiscal Year 1983) and included amortization and operation and maintenance costs. A 100-year economic life was assumed in evaluating plans associated with levees, floodwalls, and bulkheads; a 50-year period of analysis was used in estimating annual equivalent costs for all nonstructural alternatives. For a more complete description of the plans and the evaluation process, refer to Appendix B - Plan Formulation, Assessment, and Evaluation.

CAPE CHARLES

Structural

The cost of the measures undertaken by the SCS was about \$320,000. The cost of the proposed dikes and flapgates in the concrete outflow sewers was not estimated.

Nonstructural

The cost of the nonstructural plans considered varied from \$103,000 to \$502,000, depending on the stage to which protection was provided and the nonstructural measures adopted. Table E-56 provides details of the nonstructural measures considered while Table E-57 presents annualized costs of the plans.

TABLE E-56
NONSTRUCTURAL MEASURES CONSIDERED
FOR CAPE CHARLES, VIRGINIA

<u>PLAN</u>		<u>COSTS</u>
A	PROTECTION TO 100-YEAR FLOOD STAGE-ELEVATION 8.0 1. Raise 11 residences and 2 commercial establishments 2. Remove household mechanical and electrical equipment from basement of 15 additional residences. Relocate to a first-floor utility room addition. 3. Construct temporary closures for basement windows of 15 residences. Sub-Total E&D @ 8% S&A @ 7%	\$230,400 168,000 38,000 <u>\$436,400</u> 34,900 30,500 <u>\$501,800</u> \$502,000
	TOTAL Rounded	
B	PROTECTION TO 100-YEAR FLOOD STAGE-ELEVATION 8.0 1. Same as for Plan A. 2. Same as for Plan A. 3. Assume that as a result of item 2 there would be no further damage in the basements of the 15 residences, thereby eliminating the need for temporary window closures in basements. Sub-Total E&D @ 8% S&A @ 7%	\$230,400 168,000 -0- <u>\$398,400</u> 31,900 27,900 <u>\$458,200</u> \$458,000
	TOTAL Rounded	
C	PROTECTION TO 35-YEAR FLOOD STAGE-ELEVATION 7.0 1. The first floor of all structures is at elevation 7 or higher. However, there are 8 residences whose first floor is at elevation 9 but whose basement windows are at elevation 6. Remove household, mechanical, and electrical equipment from basement of these 9 residences. Relocate to a first-floor utility addition. 2. Construct temporary closures for basement windows of 8 residences. Sub-Total E&D @ 8% S&A @ 7%	\$89,700 20,300 <u>\$110,000</u> 8,800 7,700 <u>\$126,500</u> \$127,000
	TOTAL Rounded	

TABLE E-56 (cont'd)

<u>PLAN</u>	<u>COSTS</u>
D PROTECTION TO 35-YEAR FLOOD STAGE-ELEVATION 7.0	
1. Same as for Plan C.	\$89,700
2. Assume that as a result of item 1 there would be no further damage in the basements of the 8 residences, thereby eliminating the need for temporary window closures in basement.	
Sub-Total	-0-
E&D @ 8%	89,700
S&A @ 7%	7,200
	6,300
TOTAL	\$103,200
Rounded	\$103,000

TABLE E-57

CAPE CHARLES NONSTRUCTURAL PLAN AVERAGE ANNUAL COSTS
(Based on January 1983 Price Levels)

PLAN	COST	COST SHARING		ANNUAL CHARGES			TOTAL
		FEDERAL	LOCAL	INTEREST AT 7 7/8%	AMORTIZATION AT 0.182%	O&M AT 1%	
A	\$502,000	\$402,000	\$100,000	\$39,500	\$900	\$5,000	\$45,400
B	458,000	366,000	92,000	36,100	800	4,600	41,500
C	127,000	102,000	25,000	10,000	200	1,300	11,500
D	\$103,000	\$82,000	\$21,000	\$8,100	\$200	\$1,000	\$9,300

NOTE: Estimates assume a 50-year project life.

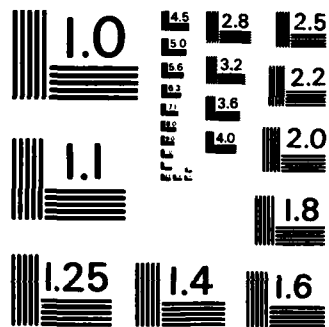

MICROCOPY RESOLUTION TEST CHART
NATIONAL BUREAU OF STANDARDS-1963-A

HAMPTON ROADS

Structural

No estimates of cost were prepared for the four sites on the Lafayette River since they were not considered feasible. The Hague area sites on the Elizabeth River, examined in the 1962 study, need to be reviewed to determine economic feasibility. In the case of the Hampton-Fox Hill area, an estimate of cost was made for building a gravity floodwall to protect most of the area selected for detailed analysis as an alternative to employing nonstructural methods. Protection to the 100-year level would cost \$3,184,000. Not included in the estimate were the costs of 10 closures, 4 of which would be across streams and 6 across roads, plus the possibility of the need for sheet piling due to the marshy condition of the soil. The cost of a pumping station was also not considered.

Nonstructural

The estimates of cost for raising the houses to the 100-year level and 25-year level are \$2,065,000 and \$904,000, respectively. Table E-58 provides details for each of the measures considered while Table E-59 presents average annual cost computations for each of the plans.

TABLE E-58

STRUCTURAL AND NONSTRUCTURAL MEASURES CONSIDERED
FOR HAMPTON, VIRGINIA

<u>PLAN</u>	<u>COSTS</u>
A	PROTECTION TO 100-YEAR FLOOD STAGE--ELEVATION 8.5
<u>Structural Measures</u>	
Floodwall to encompass 50 structures	
Floodwall height (ground elevation - 3.5)	
Below ground	1 ft.
Above ground to elevation 8.5	5 ft.
Freeboard	3 ft.
Total	9 ft.
Length	6200 ft.
Sub-Total	Cost = 6,200 ft. X \$446.50/ft.
E&D @ 8%	\$2,768,300
S&A @ 7%	221,500
Total	193,800
Rounded	\$3,183,600
	\$3,184,000
B	PROTECTION TO 100-YEAR FLOOD STAGE--ELEVATION 8.5
<u>Nonstructural Measures</u>	
Raise 8 structures 8"	\$296,500
Raise 17 structures 2'	504,500
Raise 25 structures 2'-8"	698,700
Raise 9 structures 4'	295,500
Sub-Total	\$1,795,200
E&D @ 8%	143,600
S&A @ 7%	125,700
Total Cost of raising 59 structures	\$2,064,500
Rounded	\$2,065,000
C	PROTECTION TO 25-YEAR FLOOD STAGE--ELEVATION 6.9
<u>Nonstructural Measures</u>	
Raise 25 structures 1'-4"	\$572,100
Raise 9 structures 2'	213,700
Sub-Total	\$785,800
E&D @ 8%	62,900
S&A @ 7%	55,000
Total cost of raising 34 structures	\$903,700
Rounded	\$904,000

TABLE E-59

HAMPTON AVERAGE ANNUAL COST COMPUTATION
(Costs Based on January 1983 Price Levels)

PLAN	COST	COST SHARING		ANNUAL CHARGES			TOTAL
		FEDERAL	LOCAL	INTEREST AT 7 7/8%	AMORTIZA- TION AT 0.182%	O&M AT 1%	
Structural, 100-year	\$3,184,000	\$2,547,000	\$637,000	\$250,700	\$5,800	\$95,500	\$352,000
Nonstructural 100-year	2,065,000	1,652,000	413,000	162,600	3,800	20,600	187,000
Nonstructural 25-year	\$904,000	\$723,000	\$181,000	\$71,200	\$1,600	\$9,000	\$81,800

NOTE: Estimates assume a 50-year project life.

POQUOSON

Structural

No estimates of cost were prepared for any of the structural plans. None of them were considered practical or economically feasible. The only exception was the provision of a flood proofed building which could be used as shelter in the event of a major tidal flood which would inundate Poquoson. Since the roads are at a low elevation, it would be necessary to investigate raising them so that the public could reach the flood proofed structure well in advance of a catastrophic flood. The Poquoson Middle School is one possibility.

Nonstructural

The estimates of cost for the various nonstructural plans of protection varied from \$199,000 to over \$8.7 million. No plans were prepared for POQ-1 since it was found that the average annual damage totalled only \$1,240 for the 100-year tidal flood stage and only \$2,600 for the 500-year level. Table E-60 provides details of the nonstructural measures considered while Table E-61 presents annualized costs of the plans.

TABLE E-60

NONSTRUCTURAL MEASURES CONSIDERED FOR
POQUOSON, VIRGINIA

<u>PLAN</u>		<u>COSTS</u>
POQ-1	Since the average annual damages in this area are less than \$1,240 at the 100-year tidal flood stage, further study of this area is not warranted.	
POQ-2	RELOCATE 96 STRUCTURES IN TRAILER COURT TO A NEW LOCATION: ¹	
	4 trailers with permanent foundation =	\$ 65,700
	92 trailers on wheels =	622,500
	Sub-Total =	688,200
	E&D @ 8% =	55,100
	S&A @ 7% =	48,200
	Total =	\$ 791,500
	Rounded =	\$ 792,000
POQ-3	PROTECTION TO 100-YEAR FLOOD STAGE—ELEVATION 8.5	
	Raise 3 structures 8" =	\$ 76,600
	Raise 33 structures 1'-4" =	572,800
	Raise 9 structures 2'-8" =	227,000
	Sub-Total =	876,400
	E&D @ 8% =	70,100
	S&A @ 7% =	61,300
	Total cost of raising 45 structures =	\$1,007,800
	Rounded =	\$1,008,000
POQ-3	PROTECTION TO 25-YEAR FLOOD STAGE—ELEVATION 7.0	
	Raise 9 structures 1' =	\$ 173,000
	E&D @ 8% =	13,800
	S&A @ 7% =	12,100
	Total cost of raising 9 structures =	\$ 198,900
	Rounded =	\$ 199,000
POQ-4	PROTECTION TO 100-YEAR FLOOD STAGE—ELEVATION 8.5	
	Raise 68 structures 8" =	\$1,040,300
	Raise 133 structures 1'-4" =	2,225,800
	Raise 115 structures 2'-8" =	2,660,900
	Raise 60 structures 3'-4" =	1,470,300
	Raise 7 structures 4'-8" =	215,000
	Sub-Total =	\$7,612,300
	E&D @ 8% =	609,000
	S&A @ 7% =	532,900
	Total cost of raising 383 structures =	\$8,754,200
	Rounded =	\$8,754,000

TABLE E-60 (Cont'd)

<u>PLAN</u>		<u>COSTS</u>
POQ-4	PROTECTION TO 25-YEAR FLOOD STAGE--ELEVATION 7.0	
	Raise 115 structures 1'-4" =	\$ 2,036,000
	Raise 60 structures 2' =	1,189,000
	Raise 7 structures 3'-4" =	168,200
	Sub-Total =	<u>\$3,393,200</u>
	E&D @ 8% =	271,500
	S&A @ 7% =	237,500
	Total cost of raising 182 structures =	\$ 3,902,200
	Rounded =	\$ 3,902,000
POQ-4	PROTECTION TO 25-YEAR FLOOD STAGE--ELEVATION 7.0	
	Purchase and demolish 58 below average value residences in poor condition and raise remaining 124 structures to 25-year flood stage--Elevation 7.0	
	Land, building and resettlement =	\$1,752,200
	Acquisition =	386,900
	Sub-Total =	<u>\$2,139,100</u>
	Demolition and site reclamation =	112,000
	Raise structures 1'-4" =	819,000
	Raise structures 2' =	1,569,600
	Raise structures 3'-4" =	97,700
	Sub-Total =	<u>\$ 2,598,300</u>
	E&D @ 8% =	207,900
	S&A @ 7% =	<u>181,900</u>
	Total cost of purchasing and demolishing 58 structures and raising 124 structures =	\$ 5,127,200
	Rounded =	\$ 5,127,000
POQ-4	PROTECTION TO 10-YEAR FLOOD STAGE--ELEVATION 5.8	
	Purchase and demolish 25 below average value residences in poor condition that are below the level of the 10-year flood stage--Elevation 5.8	
	Land, building and resettlement =	\$755,300
	Acquisition =	166,800
	Sub-Total =	<u>922,100</u>
	Demolition and site reclamation =	48,300
	E&D @ 8% =	3,900
	S&A @ 7% =	<u>3,400</u>
	Total cost of purchasing and demolishing 25 structures =	\$977,700
	Rounded =	\$ 978,000

¹ The structures would be relocated to an area at least 1-foot above the 1,000 year flood (elevation 11 feet NGVD).

TABLE E-61

POQUOSON AVERAGE ANNUAL NONSTRUCTURAL COST COMPUTATION
(Costs Based on January 1983 Price Levels)

PLAN	CONSTRUCTION COST	COST SHARING		INTEREST AT 7-7/8%	AMORTIZATION AT 0.182%	O&M AT 1%	TOTAL
		FEDERAL	LOCAL				
POQ-2	\$ 792,000	\$ 634,000	\$ 158,000	\$ 62,400	\$ 1,400	\$ 7,900	\$ 71,700
POQ-3	1,008,000	806,000	202,000	79,400	1,800	10,100	91,300
POQ-3	199,000	159,000	40,000	15,700	400	2,000	18,100
POQ-4	8,754,000	7,003,000	1,751,000	689,400	15,900	87,500	792,800
POQ-4	3,902,000	3,122,000	780,000	307,300	7,100	39,000	353,400
POQ-4*	5,127,000	4,102,000	1,025,000	322,500	7,400	51,300	381,200**
POQ-4***	\$ 978,000	\$ 782,000	\$ 196,000	\$ 42,000	\$ 1,000	\$ 9,800	\$ 52,800**

*Purchase and demolish 58 structures. Raise 124 structures.

**Excludes interest and amortization on cost of resettlement.

***Purchase and demolish 25 structures.

NOTE: Estimates assume a 50-year project life.

TANGIER ISLAND

Structural

The cost of protecting the West Ridge, Main Ridge, and Canton Ridge by concrete cantilever walls to the level of the 100-year tidal flood stage, based on Corps frequency data, was estimated at over \$24 million. The cost of protecting the school on Tangier Island to the level of the standard project tidal flood, (elevation 13) as estimated by the Corps, was \$1,697,000.

It was not considered practical to provide long walls to protect single line houses and other structures along the three ridges on Tangier Island from tidal flooding. The environmental agencies would undoubtedly object to crowding the marshes, and the people on the island would not care to have the small amount of useable land removed for this purpose. Nevertheless, a preliminary estimate of the cost of such structural measures was prepared. Each of the three walls around the three ridges was designed to the level of the 100-year tidal stage plus freeboard. Top of wall elevations for each ridge were estimated to be 11 feet. The height of the wall above ground for West Ridge and Main Ridge was estimated to be 7 feet while the wall height around Canton Ridge was estimated to be about 1-foot lower.

A cantilever wall was adopted in order to utilize the least amount of land. It would include a 15-foot steel sheet pile cutoff wall. About 2,600 feet would be required for the Canton Ridge, 7,200 feet would be required for the West Ridge, and approximately the same amount for the Main Ridge. Table E-62 presents an estimate of cost. No estimate based on VIMS frequency was necessary since the 100-year elevation is close to the level of the ground.

TABLE E-62

**COST OF FLOODWALLS ON TANGIER TO THE 100-YEAR CORPS
TIDAL FLOOD STAGE
(Based on January 1983 Price Levels)**

<u>ITEM</u>	<u>UNIT</u>	<u>AMOUNT</u>	<u>COST PER UNIT</u>	<u>TOTAL COST</u>
Sheet piling	sq. ft.	272,000	\$ 16.50	\$ 4,488,000
Forms	sq. ft.	333,000	1.65	549,450
Concrete	c.y.	19,584	440.00	8,616,960
Closures	L.S.	10	Job	220,000
	Subtotal			\$13,874,410
Contingencies @ 20%				2,774,880
	Subtotal			\$16,649,290
E&D @ 8%				1,331,940
S&A @ 7%				1,165,450
	Subtotal			\$19,146,680
	TOTAL			\$24,891,000

NOTE: Costs were updated from July 1979 to January 1983 by a factor of 1.30.

A plan was developed for protecting a building to be used as a shelter. There are three structures that might be suitable for this purpose—the Methodist Church, the recreation center, and the school. There would be difficulty in flood proofing these structures. Some land, houses, and roads may also be affected.

The school appeared to offer the most practical alternative. According to the principal in 1980, Mr. Harold G. Wheatley, the emergency plans call for the people of Tangier to go to the school. The building does have flood preparation facilities.

In order to reduce the amount of area required for the protection structure, a cantilever concrete wall was envisaged. Sheet piling would be required below ground level. It would rise to a height of 12.5 feet above ground level. Nine hundred feet of wall would encircle the school and be a reasonable distance from it. Table E-63 provides a cost estimate for this alternative.

TABLE E-63
 COST OF PROTECTING THE TANGIER SCHOOL
 (Based on January 1983 Price Levels)

<u>ITEM</u>	<u>UNIT</u>	<u>AMOUNT</u>	<u>COST PER UNIT</u>	<u>TOTAL COST</u>
Sheet piling	sq. ft.	15,200	\$16.50	\$ 250,800
Forms	sq. ft.	26,850	1.65	44,300
Concrete	c.y.	1,429	440.00	628,760
Closures	L.S.	L.S.	Job	<u>22,000</u>
Subtotal				\$ 945,860
Contingencies @ 20%				<u>189,170</u>
Subtotal				\$1,135,030
E&D @ 8%				90,800
S&A @ 7%				<u>79,450</u>
Subtotal				<u>\$1,305,280</u>
TOTAL				\$1,697,000

NOTE: A factor of 1.30 was used to update costs from July 1979 to January 1983.

Nonstructural

The cost of the nonstructural plans considered vary from \$180,000 to \$7.78 million, depending on the stage to which protection is provided. Table E-64 provides details for the nonstructural measures considered while Table E-65 presents estimates of average annual costs for the nonstructural plans.

TABLE E-64

NONSTRUCTURAL MEASURES CONSIDERED FOR
TANGIER, VIRGINIA
(Based on January 1983 Price Levels)

<u>PLAN</u>		<u>COSTS</u>
A	PROTECTION TO 100-YEAR FLOOD STAGE—ELEVATION 8.5 (CORPS FREQUENCY)	
	Raise 5 structures 0-8"	\$ 57,800
	Raise 46 structures 1'-4"	702,810
	Raise 121 structures 2'-8"	2,322,880
	Raise 125 structures 3'-4"	2,702,100
	Raise 23 structures 4'-8"	646,100
	Raise 9 structures 5'-4"	259,400
	Raise 2 structures 6'-8"	75,400
	Sub-Total	<u>6,766,490</u>
	E&D @ 8%	541,320
	S&A @ 7%	473,650
	Total cost of raising 331 structures	<u>\$7,781,460</u>
	Rounded	\$7,781,000
B	PROTECTION TO 25-YEAR FLOOD STAGE—ELEVATION 7.0 (CORPS FREQUENCY)	
	Raise 1 structure 1'-4"	\$1,684,780
	Raise 5 structures 2'-0"	2,066,640
	Raise 3 structures 3'-4"	521,900
	Raise 9 structures 4'-0"	205,570
	Raise 2 structures 5'-4"	66,120
	Sub-Total	<u>4,545,010</u>
	E&D @ 8%	363,600
	S&A @ 7%	318,150
	Total cost of raising 280 structures	<u>\$5,226,760</u>
	Rounded	\$5,227,000

TABLE E-64 (cont'd)

<u>PLAN</u>	<u>COSTS</u>
C	
PROTECTION TO 100-YEAR FLOOD STAGE—ELEVATION 4.1 (VIMS FREQUENCY) ¹	
Raise 9 structures 1'-4"	\$ 119,130
Raise 2 structures 2'-0"	37,430
Sub-Total	<u>156,560</u>
E&D @ 8%	12,520
S&A @ 7%	10,960
Total cost of raising 11 structures	<u>\$ 180,040</u>
Rounded	\$ 180,000

¹ Protection to elevation 4.1 provides protection to 4.2-year flood stage - Corps frequency.

TABLE E-65

ANNUAL COSTS OF STRUCTURAL AND NONSTRUCTURAL PLANS
ON TANGIER ISLAND
(Based on January 1983 Price Levels)

PLAN (\$1,000)	CONSTRUCTION COST SHARING (\$1,000)		ANNUAL CHARGES (\$1,000)			TOTAL	
	FEDERAL	LOCAL	INTEREST AT 7-7/8%	AMORTIZA- TION AT 0.182%	O&M ¹		
Structural 100-yr(C)	\$24,891	\$19,913	\$4,978	\$1,960.2	\$ 45.3	\$ 497.8	\$2,503.3
Stand. Proj. Fld. (C) ²	1,697	1,358	339	133.6	3.1	33.9	170.6
Nonstructural 100-yr(C)	7,781	6,225	1,556	612.8	14.2	77.8	704.8
25-yr(C)	5,227	4,182	1,045	411.6	9.5	52.3	473.4
100-yr(V)	\$ 180	\$ 144	\$ 36	\$ 14.2	\$ 0.3	\$ 1.8	\$ 16.3

¹ Structural O&M @ 2%, Nonstructural O&M @ 1%.

² For protection of the Tangier School.

NOTE: C = Frequency based on Corps estimate.

V = Frequency based on VIMS estimate.

WEST POINT

Structural

No estimates of cost were prepared for any structural plans. None were considered to be practical or economically feasible.

Nonstructural

In the study area which includes 15th Street and below, the estimates of cost for the nonstructural plans varied from \$90,000 to \$1,048,000 depending on whether the stage-frequency curve was based on Corps or VIMS estimates. Table E-66 provides details for the nonstructural measures considered while Table E-67 presents the average annual costs for the nonstructural tidal flood protection plans considered.

TABLE E-66

NONSTRUCTURAL MEASURES CONSIDERED FOR WEST POINT, VIRGINIA

<u>PLAN</u>	<u>COSTS</u>
A PROTECTION TO THE 100-YEAR FLOOD STAGE - ELEVATION 8.5 (CORPS FREQUENCY)	
Raise 19 structures 0.5'	\$ 309,400
Raise 7 structures 1.5'	139,100
Raise 2 structures 2.5'	48,900
Raise 12 structures 3.5'	316,400
Raise 3 structures 4.5'	97,700
Sub-Total	<u>911,500</u>
E&D @ 8%	72,900
S&A @ 7%	63,800
Total cost of raising 43 structures	\$1,048,200
Rounded	\$1,048,000
B PROTECTION TO THE 25-YEAR FLOOD STAGE - ELEVATION 7.0 (CORPS FREQUENCY)	
Raise 2 structures 1'	\$ 35,100
Raise 12 structures 2'	270,600
Raise 3 structures 3'	98,500
Sub-Total	<u>404,200</u>
E&D @ 8%	32,300
S&A @ 7%	28,300
Total cost of raising 17 structures	\$ 464,800
Rounded	\$ 465,000
C PROTECTION TO THE 100-YEAR FLOOD STAGE - ELEVATION 6.0 (VIMS FREQUENCY)¹	
Raise 12 structures 1'	\$ 223,200
Raise 3 structures 2'	72,300
Sub-Total	<u>\$ 295,500</u>
E&D @ 8%	23,600
S&A @ 7%	20,700
Total cost of raising 15 structures	\$ 339,800
Rounded	\$ 340,000

TABLE E-66 (cont'd)

<u>PLAN</u>	<u>COSTS</u>
D PROTECTION TO THE 25-YEAR FLOOD STAGE - ELEVATION 5.0 (VIMS FREQUENCY) ²	
Raise 3 structures 1'	\$ 78,500
E&D @ 8%	6,300
S&A @ 7%	5,500
Total cost of raising 3 structures	\$ 90,300
Rounded	\$ 90,000

¹ Protection to elevation 6.0 provides protection to 12-year flood stage-Corps frequency.

² Protection to elevation 5.0 provides protection to 6-year flood stage-Corps frequency.

TABLE E-67

WEST POINT AVERAGE ANNUAL NONSTRUCTURAL COST COMPUTATION
(Based on January 1983 Price Levels)

PLAN	CONSTRUCTION COSTS		COST SHARING		INTEREST AT 7-7/8%	AMORTIZATION AT 0.182%		O&M TOTAL
	FEDERAL	LOCAL	FEDERAL	LOCAL		AT 1%	TOTAL	
100-year(C)	\$1,048,000	\$210,000	\$838,000	\$210,000	\$82,500	\$1,900	\$10,500	\$94,900
25-year(C)	465,000	93,000	372,000	93,000	36,600	800	4,700	42,100
100-year(V)	340,000	68,000	272,000	68,000	26,800	600	3,400	30,800
25-year(V)	\$90,000	\$18,000	\$72,000	\$18,000	\$7,100	\$200	\$900	\$8,200

NOTE: C = Corps Estimate, V = VIMS Estimate

CHESAPEAKE BAY
TIDAL FLOODING STUDY

APPENDIX F
ECONOMICS

Department of the Army
Baltimore District, Corps of Engineers
Baltimore, Maryland
September 1984

702

CHESAPEAKE BAY TIDAL FLOODING STUDY

APPENDIX F - ECONOMICS

TABLE OF CONTENTS

<u>Item</u>	<u>Page</u>
Introduction	F-1
Methodology	F-1
Benefits	F-2
Recreation Benefits	F-2
Intensification Benefits	F-2
Inundation Reduction Benefits	F-2
Location Benefits	F-2
Employment Benefits	F-2
Costs	F-3
Maryland Flood-Prone Communities	F-3
Cambridge, Maryland	F-3
Without Project Conditions	F-3
Future Growth	F-5
Damages	F-5
With Project Conditions	F-5
Crisfield, Maryland	F-6
Without Project Conditions	F-6
Future Growth	F-6
Damages	F-9
With Project Conditions	F-9
Pocomoke City, Maryland	F-11
Without Project Conditions	F-11
Future Growth	F-11
Damages	F-11
With Project Conditions	F-13
Rock Hall, Maryland	F-13
Without Project Conditions	F-13
Future Growth	F-16
Damages	F-16
With Project Conditions	F-16
Snow Hill, Maryland	F-17
Without Project Conditions	F-17
Future Growth	F-20
Damages	F-20
With Project Conditions	F-20
St. Michaels, Maryland	F-22
Without Project Conditions	F-22
Future Growth	F-22
Damages	F-22
With Project Conditions	F-24
Tilghman Island, Maryland	F-24
Without Project Conditions	F-24
Future Growth	F-26
Damages	F-26
With Project Conditions	F-26

TABLE OF CONTENTS (Cont'd)

<u>Item</u>	<u>Page</u>
Virginia Flood-Prone Communities	F-28
Cape Charles, Virginia	F-28
Without Project Conditions	F-28
Future Growth Without Project	F-31
Stage-Damage Relationship Without Project	F-31
Affluence Factor Benefits	F-34
Inundation Reduction Benefits	F-34
Average Annual Costs and Benefits	F-34
Hampton Roads, Virginia	F-35
Without Project Conditions	F-35
Future Growth Without Project	F-36
Stage-Damage Relationship Without Project	F-36
Benefits	F-39
Average Annual Costs and Benefits	F-40
Poquoson, Virginia	F-40
Without Project Conditions	F-40
Future Growth Without Project	F-45
Stage-Damage Relationship Without Project	F-45
Affluence Factor Benefits	F-47
Inundation Reduction Benefits	F-47
Average Annual Costs and Benefits	F-47
Tangier Island, Virginia	F-60
Without Project Conditions	F-60
Future Growth Without Project	F-60
Stage-Damage Relationship Without Project	F-60
Affluence Factor Benefits	F-63
Inundation Reduction Benefits	F-63
Average Annual Costs and Benefits	F-63
West Point, Virginia	F-68
Without Project Conditions	F-68
Future Growth Without Project	F-68
Stage-Damage Relationship Without Project	F-68
Affluence Factor Benefits	F-72
Inundation Reduction Benefits	F-72
Average Annual Costs and Benefits	F-73

LIST OF FIGURES

<u>Number</u>	<u>Title</u>	<u>Page</u>
F-1	Cape Charles Flood Area	F-30
F-2	Cape Charles Stage-Damage Relationship	F-32
F-3	Hampton-Fox Hill Area Stage-Damage Relationship	F-37
F-4	Poquoson Flood Area	F-43
F-5	Poquoson Existing Land Use	F-44
F-6	Poquoson Future Land Use	F-46
F-7	Poquoson Area One Stage-Damages	F-48
F-8	Poquoson Area Two Stage-Damages	F-49
F-9	Poquoson Area Three Stage-Damages	F-50
F-10	Poquoson Area Four Stage-Damages	F-51
F-11	Tangier Island Stage-Damage Relationship	F-61
F-12	West Point Flood Area	F-69
F-13	West Point Stage-Damage Relationship	F-70

LIST OF TABLES

<u>Number</u>	<u>Title</u>	<u>Page</u>
F-1	Cambridge Flood Plain Inventory	F-4
F-2	Summary Economic Analysis of Alternative Plans for Cambridge	F-7
F-3	Crisfield Flood Plain Inventory	F-8
F-4	Summary Economic Analysis of Alternative Plans for Crisfield	F-10
F-5	Pocomoke City Flood Plain Inventory	F-12
F-6	Summary Economic Analysis of Alternative Plans for Pocomoke City	F-14
F-7	Rock Hall Flood Plain Inventory	F-15
F-8	Summary Economic Analysis of Alternative Plans for Rock Hall	F-18
F-9	Snow Hill Flood Plain Inventory	F-19
F-10	Summary Economic Analysis of Alternative Plans for Snow Hill	F-21
F-11	St. Michaels Flood Plain Inventory	F-23
F-12	Summary Economic Analysis of Alternative Plans for St. Michaels	F-25
F-13	Tilghman Island Flood Plain Inventory	F-27
F-14	Summary Economic Analysis of Alternative Plans for Tilghman Island	F-29
F-15	Cape Charles Average Annual Flood Damages	F-33
F-16	Cape Charles Average Annual Nonstructural Costs	F-34
F-17	Cape Charles Average Annual Nonstructural Benefits	F-35
F-18	Cape Charles Net Nonstructural Benefits	F-35
F-19	Hampton-Fox Hill Area Average Annual Flood Damages	F-38
F-20	Hampton Residential Flood Reduction Benefits	F-39

LIST OF TABLES (Cont'd)

<u>Number</u>	<u>Title</u>	<u>Page</u>
F-21	Hampton Average Annual Costs	F-41
F-22	Hampton Average Annual Benefits	F-42
F-23	Poquoson Future Residential Land Use	F-45
F-24	Poquoson Area One Average Annual Flood Damages	F-52
F-25	Poquoson Area Two Average Annual Flood Damages	F-53
F-26	Poquoson Area Three Average Annual Flood Damages	F-54
F-27	Poquoson Area Four Average Annual Flood Damages	F-55
F-28	Poquoson Inundation Reduction Benefits	F-56
F-29	Poquoson Average Annual Nonstructural Costs	F-57
F-30	Poquoson Average Annual Nonstructural Benefits	F-58
F-31	Poquoson Net Nonstructural Benefits and B-C Ratios	F-59
F-32	Tidal Stage-Damage Data for Tangier	F-62
F-33	Per Capita Income, BEA Economic Area 017	F-63
F-34	Tangier Residential Flood Reduction Benefits	F-64
F-35	Tangier Annual Costs of Structural and Nonstructural Plans	F-65
F-36	Tangier Average Annual Benefits	F-66
F-37	Tangier Economic Analysis	F-67
F-38	West Point Average Annual Flood Damages - Corps Frequency	F-71
F-39	West Point Average Annual Flood Damages - VIMS Frequency	F-72
F-40	West Point Inundation Reduction Benefits	F-73
F-41	West Point Average Annual Nonstructural Costs	F-74
F-42	West Point Average Annual Nonstructural Benefits	F-75
F-43	West Point Net Nonstructural Benefits and B-C Ratios	F-75

LIST OF ANNEXES

<u>Number</u>	<u>Title</u>	<u>Page</u>
F-I	Cambridge Stage-Damage and Average Annual Damage Computations	F-I-1
F-II	Crisfield Stage-Damage and Average Annual Damage Computations	F-II-1
F-III	Pocomoke City Stage-Damage and Average Annual Damage Computations	F-III-1
F-IV	Rock Hall Stage-Damage and Average Annual Damage Computations	F-IV-1
F-V	Snow Hill Stage-Damage and Average Annual Damage Computations	F-V-1
F-VI	St. Michaels Stage-Damage and Average Annual Damage Computations	F-VI-1
F-VII	Tilghman Island Stage-Damage and Average Annual Damage Computations	F-VII-1

APPENDIX F

ECONOMICS

INTRODUCTION

The purpose of this appendix is to provide the stage-damage and cost information necessary for the economic evaluation of plans considered for the tidal flood-prone communities. This appendix presents a general discussion of the methodology used in the economic evaluation. This includes discussions on benefit determination and cost estimates as well as an overview of the analytical procedure used. This then proceeds to a community analysis and a comparison of "without" and "with" project conditions.

METHODOLOGY

Beneficial effects to National Economic Development (NED) are increases in the economic value of the national output of goods and services resulting from a plan. Beneficial effects to Environmental Quality (EQ) are favorable changes in the quantity of natural and cultural resources or in the quality of these resources as measured by their ecological, aesthetic, or cultural attributes. Adverse effects to NED are the opportunity costs of resources used in the implementation of structural and nonstructural aspects of a plan. Adverse effects to EQ are unfavorable changes in the quantity of natural and cultural resources or in the quality of these resources as measured by ecological, aesthetic and cultural attributes. The economic justification of alternative plans can be ascertained by comparing combined NED and EQ beneficial effects to those combined NED and EQ adverse effects which will most probably be realized over the project life. In order for a plan to be economically justified it must have net benefits; that is, the combined beneficial effects must outweigh the combined adverse effects.

The values given to benefits and costs at the time of their occurrence are made comparable by conversion to an equivalent time basis using an appropriate interest rate. At the time of the tidal flooding analysis, a Federal interest rate of 7 1/8 percent was used. This was the rate at which all water resources projects were evaluated in fiscal year 1980. Future costs and benefits were discounted to the base year of 1995 where applicable. A number of economic and physical forces limit the economic life of a project such as physical depreciation, obsolescence, changing requirements for project services, and inaccuracies in making extended projections. Based on these factors, an economic life of 100 years was selected for structural measures and an economic life of 50 years was selected for nonstructural measures.

The development of costs and benefits followed the Procedures for Evaluation of NED Benefits and Costs in Water Resources Planning. Costs and benefits were based on April 1980 price levels for those plans in the State of Maryland evaluated by the Baltimore District. Plans for the Virginia communities evaluated by the Norfolk District were based on January 1983 price levels. Costs and benefits were evaluated at a level of detail appropriate to the results of the economic analyses. Plans for any community which were clearly economically infeasible did not receive a rigorous analysis of future benefits.

BENEFITS

Benefits from plans for reducing flood hazards accrue primarily through the reduction in actual or potential damages associated with land use. While there is only one benefit standard, there are three benefit categories, reflecting three different responses to a flood hazard reduction plan. This section discusses these benefit categories and the assumptions regarding those benefits which are common to all the projects considered.

RECREATION BENEFITS

No effort was made to compute potential recreation benefits as they were considered to be incidental for the scope and nature of the alternatives under consideration.

INTENSIFICATION BENEFITS

If the type of floodplain use is unchanged but the method of operation is modified because of a plan, the benefit is the increased net income which may be generated by the increased or intensified floodplain activity.

INUNDATION REDUCTION BENEFITS

If floodplain use is the same with and without a project, the benefit is the increased net income generated by that use. The benefit is the difference in flood damages with and without the project, plus the reduction in flood proofing costs, plus the reduction in insurance overhead, plus the restoration of land values in certain situations. If an activity is removed from the floodplain, this inundation reduction benefit is realized only to the extent that removal of the activity increases the net income of other activities in the economy.

LOCATION BENEFITS

If an activity is added to the floodplain because of a plan, the benefit is the difference between aggregate net incomes (including economic rent) in the economically affected area with and without the plan.

EMPLOYMENT BENEFITS

If labor resources which would otherwise have been unemployed or underemployed are used directly in project construction, an NED employment benefit may result. To facilitate estimation of NED employment benefits for qualified communities some assumptions were made. Thirty percent of estimated construction costs (excluding land) was assumed to be labor costs. Labor requirements for construction were assumed to be 75 percent skilled, 20 percent unskilled and 5 percent other. The average wage rates (including overhead) for the skill levels were estimated to be \$31,760 for a skilled worker, \$25,300 for an unskilled worker, and \$20,840 for other workers. These assumed values were based on averages observed during the construction of similar projects. For purposes of this study, it was assumed that project construction would take two years and 50 percent of the labor would be required each year.

To determine employment benefits the labor requirements per skill category per year were computed by the following equation:

$$\frac{FC \times PLC \times PSC}{SCW} = \text{Number of Workers for Skill Category}$$

where:

FC = First Costs of Project
PLC = Percentage of Costs that are Labor Costs
PSC = Percentage of Labor Force in Skill Category
SCW = Skill Category Wage

If there are more unemployed workers in the specific skill category, a local hire rule was assumed and the construction wage bill was used to compute average annual benefits.

COSTS

In the following sections the estimated first costs of construction for alternative plans are presented for each community. Contingencies, engineering and design (E&D), costs, and supervision and administration (S&A) costs are included in this total. The basis for costs presented is discussed in Appendix E - Engineering Design and Cost Estimates. The economic cost of interest during construction is not included in the gross investment costs of these projects. Annual costs presented in this Appendix are based on the present worth of first costs at the time of construction and annual operation and maintenance. No allocation of cost is required.

MARYLAND FLOOD-PRONE COMMUNITIES

CAMBRIDGE, MARYLAND

WITHOUT PROJECT CONDITIONS

There are an estimated 3,400 acres within the community of Cambridge as described in Appendix A - Problem Identification. Cambridge is subjected to tidal and fluvial flooding on the Choptank River and Cambridge Creek. However, fluvial flooding was not evaluated in this study. The 100-year flood hazard zone (5.9' NGVD) covers about 70 acres of the community. Of this area 76 percent (53 acres) is developed. The 500-year flood hazard zone (7.5' NGVD) covers about 139 acres. Of this amount 88 percent (122 acres) is currently developed.

The Cambridge flood plain is primarily residential in character with the non-residential development primarily located on the waterfront. Table F-1 summarizes the type of development in various flood hazard zones. About 80 percent of the structures in the flood plain are residential. Conversations with Cambridge residents and local insurance agents indicated that the value of the contents of an average residential structure was about 40 percent of the structure value.

TABLE F-1
CAMBRIDGE FLOOD PLAIN INVENTORY
(April 1980 Prices)

AVERAGE STAGE (NGVD)	APPROXIMATE FLOOD HAZARD ZONE	NUMBER OF STRUCTURES			ANNUAL DAMAGES		
		Residential	Commercial	Industrial		Public & Other	Total
4 feet	12 year (8.2%)	0	2	2	0	4	\$4,000
6 feet	120 year (0.82%)	60	14	2	0	76	\$12,000
8 feet	500 year (0.20%)	139	29	3	0	171	\$15,000
18 feet	SPTF	359	50	3	0	412	\$19,000

FUTURE GROWTH

Cambridge is not subjected to strong developmental pressures and any changes in Cambridge's level of development in the future will be minor. The real value of residential contents was estimated to grow at the OBERS regional growth rate for per capita income for BEA Area 17. The annual growth rate was 2.6 percent. The value of residential contents, estimated to be 40 percent of the structure value, was projected to grow at a rate of 2.6 percent annually until 2005, at which time the content value would equal 75 percent of structure value. Growth in real value of contents was limited to 75 percent of structure value. Residential contents would increase 47 percent from 1980 to 1995 with an affluence factor of 1.22.

DAMAGES

A flood damage survey of all development within the Standard Project Flood Plain was conducted in Cambridge in November 1979. Average annual damages were computed using standard damage-frequency curve and integration techniques. Stage-damage and average annual damage tables and/or computations are presented in Annex F-I

With the affluence factor analysis, average annual damages increased by less than \$500 and were considered to be negligible. As noted above, little new development is anticipated in this community. However, to test the sensitivity of any plan's feasibility to future development, an extreme upper limit on average annual damages was estimated. To do this it was assumed that the approximate 17 acres of undeveloped floodplain land would be immediately developed in a manner reflective of existing development patterns. Damage at and below the 100-year flood was increased by 25 percent while damages above the 100-year flood were increased by 15 percent (different percentages reflect increasing flood plain size). Under these extreme assumptions of full development, average annual damages were estimated to be \$23,000 as compared with annual damages of \$19,000 without the development.

WITH PROJECT CONDITIONS

The presence of either a structural or a nonstructural plan of improvement would not be expected to influence either the size of the floodplain or the level of development in any way that would differ from the without project land use. As a result of providing protection from tidal flooding, NED benefits would accrue. The benefits considered are discussed in the following paragraphs and the average annual damage computations for the with project conditions are included in Annex F-I.

Land use is expected to be the same in Cambridge with and without a plan and no increased economic activity resulting from a plan is anticipated. There is no potential for intensification benefits in Cambridge. For the same reason there is no potential for location benefits.

Dorchester County, Maryland, has been designated by the Economic Development Administration, U.S. Department of Commerce, as an area of "substantial and persistent unemployment" under Sub-Section 1 of Title IV of the Public Works and Economic Development Act of 1966. Because sufficient unemployed labor resources are available for employment, all plans would result in NED employment benefits.

Inundation reduction benefits would accrue to both the structural and nonstructural plans. An affluence factor was computed for the residential content damages and was found to be negligible. The summary economic analyses of six structural and two nonstructural plans are presented in Table F-2.

In order to test the sensitivity of structural project feasibility to future development, inundation reduction benefits in Table F-2 were proportionately increased to \$7,000, \$6,000, \$4,000, \$12,000, \$8,000, and \$6,000, for Plans CA-1 through CA-6, respectively. The benefit-cost ratios for the structural plans remained at 0.1 to 1. Nonstructural plans were not reevaluated because it was assumed that new development would comply with National Flood Insurance Program floodproofing requirements. There were no economically justified plans identified for Cambridge. Economic justification is insensitive to a more rigorous evaluation of future benefits and there is no realistic potential for unquantifiable EQ benefits.

CRISFIELD, MARYLAND

WITHOUT PROJECT CONDITIONS

The community of Crisfield is approximately 2,100 acres in size and approximately 50 percent of the community is subject to tidal flooding. The community may be subjected to high velocity flooding as a result of the direct assault of waves on development. With the presence of a major Bay harbor in Crisfield, there is the potential for high debris content in flood waters if boats break loose or if waterfront structures are battered by waves in a major storm.

The 100-year flood hazard zone (5.1' NGVD) covers about 938 acres of the community. Of this area 73 percent (683 acres) is developed. The 500-year flood hazard zone (6.1' NGVD) covers about 1,283 acres. Of this amount 71 percent (913 acres) is currently developed.

The Crisfield flood plain is primarily residential in character with some non-residential development. Table F-3 summarizes the type of development in various flood hazard zones. About 85 percent of the structures in the flood plain are residential. Conversations with Crisfield residents and local insurance agents indicated that the value of the contents of an average residential structure was about 40 percent of the structure value.

FUTURE GROWTH

Crisfield is not subjected to strong developmental pressures and any changes in Crisfield's level of development in the future will be minor. The real value of residential contents was estimated to grow at the OBERS regional growth rate for per capita income for BEA Area 17, which includes Crisfield. Per capita income was estimated to grow at an annual rate of 2.6 percent. The value of residential contents, estimated to be 40 percent of structure value, was projected to grow at a rate of 2.6 percent annually until 2005, at which time the content value would equal 75 percent of structure value. Growth in real value of contents beyond 75 percent of structure value was not estimated. Residential contents would increase by 47 percent from 1980 to 1995 with an affluence factor of 1.22.

TABLE F-2
 SUMMARY ECONOMIC ANALYSIS OF ALTERNATIVE PLANS FOR CAMBRIDGE
 (April 1980 Prices)
 (\$1,000's)

ITEM	PLAN							
	CA-1	CA-2	CA-3	CA-4	CA-5	CA-6	CA-7	CA-8
Costs								
First Annual	\$7,588	\$5,869	\$5,156	\$9,121	\$7,028	\$6,061	\$357	\$749
I&A	541	419	368	651	501	432	26	55
O&M	47	36	32	56	44	38	0	0
Total	\$588	\$455	\$400	\$707	\$545	\$470	\$26	\$55
Benefits								
Intensification	\$ 0	\$ 0	\$ 0	\$ 0	\$ 0	\$ 0	\$ 0	\$ 0
Location	0	0	0	0	0	0	0	0
Employment	79	61	54	94	72	62	4	8
Inundation Reduction								
Existing	6	5	3	10	7	5	10	12
Future*	0	0	0	0	0	0	0	0
Total	\$ 85	\$ 66	\$ 57	\$104	\$ 79	\$ 67	\$14	\$20
Net Benefits	-\$503	-\$389	-\$343	-\$603	-\$466	-\$403	-\$12	-\$35
Benefit-Cost Ratio	0.1	0.1	0.1	0.1	0.1	0.1	0.5	0.4

*Consists of affluence factor for residential contents only.

TABLE F-3
 CRISFIELD FLOOD PLAIN INVENTORY
 (April 1980 Prices)

STAGE (NGVD)	APPROXIMATE FLOOD HAZARD ZONE	NUMBER OF STRUCTURES			Public & Other	Total	AVERAGE ANNUAL DAMAGES
		Residential	Commercial	Industrial			
4 feet	12 year (8.2%)	57	69	0	3	129	\$40,000
5 feet	80 year (1.2%)	564	162	3	13	742	\$102,000
6 feet	400 year (0.25%)	1,133	193	4	18	1,348	\$129,000
12 feet	500 year (0.20%)	1,679	208	4	31	1,922	\$146,000

DAMAGES

A flood damage survey was conducted in Crisfield in November 1979. Average annual damages were computed using standard damage-frequency curve and integration techniques. Details and pertinent data for calculating the stage-damage relationship and existing average annual damages of \$146,000 for Crisfield's development are presented in Annex F-II.

With the affluence factor analysis, average annual damages increased by \$5,000 to \$151,000. As noted above, little new development is anticipated in this community. However, to test the sensitivity of any plan's feasibility to future development an extreme upper limit on average annual damages was estimated. To do this it was assumed that the approximate 370 acres of undeveloped land would be immediately developed in a manner reflective of existing development patterns. Damages at and below the 100-year flood were increased by 25 percent while damages above the 100-year flood were increased by 30 percent (different percentages reflect increasing flood plain size). Under these extreme assumptions of full development, average annual damages were estimated to be \$185,000.

WITH PROJECT CONDITIONS

The presence of either a structural or a nonstructural plan of improvement would not be expected to influence either the size of the flood plain or the level of development in any way that would differ from without project land use. As a result of providing protection from tidal flooding NED benefits would accrue. The benefits considered are discussed in the following paragraphs and the average annual damage computations for the with project conditions are included in Annex F-II.

Land use is expected to be the same in Crisfield with and without a plan and no increased economic activity resulting from a plan is anticipated. There is no potential for intensification benefits in Crisfield. For the same reason there is no potential for location benefits.

Somerset County, Maryland, has been designated by the Economic Development Administration, U.S. Department of Commerce, as an area of "substantial and persistent unemployment" under Sub-section 1 of Title IV of the Public Works and Economic Development Act of 1966. Because sufficient unemployed labor resources are available for employment, all plans would result in NED employment benefits.

Inundation reduction benefits would accrue to both the structural and nonstructural plans. An affluence factor was computed for the residential content damages. The summary economic analyses of four structural and two nonstructural plans are presented in Table F-4.

In order to test the sensitivity of project feasibility to future development, inundation reduction benefits for Plans CR-1 through CR-4 were increased to \$92,000, \$86,000, \$120,000 and \$112,000, respectively, in accordance with the future development assumption explained above. The benefit-cost ratios for the plans remained 0.3 to 1 even with these increases in inundation reduction benefits. Nonstructural plans were not reevaluated because it was assumed that new development would comply with National Flood Insurance Program floodproofing requirements.

TABLE F-4
 SUMMARY ECONOMIC ANALYSIS OF ALTERNATIVE PLANS FOR CRISFIELD
 (April 1980 Prices)
 (\$1,000's)

ITEM	PLAN					
	<u>CR-1</u>	<u>CR-2</u>	<u>CR-3</u>	<u>CR-4</u>	<u>CR-5</u>	<u>CR-6</u>
Costs						
First	\$ 7,019	\$ 7,333	\$ 5,807	\$ 7,215	\$ 676	\$ 6,294
Annual						
I&A	501	523	414	515	50	463
O&M	42	44	35	43	0	0
Total	\$ 543	\$ 567	\$ 449	\$ 558	\$ 50	\$ 463
Benefits						
Intensification	\$ 0	\$ 0	\$ 0	\$ 0	\$ 0	\$ 0
Location	0	0	0	0	0	0
Employment	72	76	60	75	7	65
Inundation Reduction						
Existing	71	92	66	85	24	89
Future*	2	3	2	3	1	3
Total	\$ 145	\$ 171	\$ 128	\$ 163	\$ 32	\$ 157
Net Benefits	-\$ 398	-\$ 396	-\$ 321	-\$ 395	-\$ 18	-\$ 306
Benefit-Cost Ratio	0.3	0.3	0.3	0.3	0.6	0.3

*Consists of affluence factor for residential contents only.

There were no economically justified plans identified for Crisfield. Economic justification is insensitive to a more rigorous evaluation of future benefits and there is no realistic potential for unquantifiable EQ benefits.

POCOMOKE CITY, MARYLAND

WITHOUT PROJECT CONDITIONS

There are an estimated 1,080 acres within the community of Pocomoke City as described in Appendix A - Problem Identification. Pocomoke City is subject to tidal flooding from the Pocomoke River. The 100-year flood hazard zone (6.3' NGVD) covers about 81 acres of the community. All of this area is developed. The 500-year flood hazard zone (7.8' NGVD) covers about 171 acres of which 84 percent (144 acres) is currently developed.

The Pocomoke City flood plain is primarily residential in character with large amounts of non-residential development. Table F-5 summarizes the type of development in various flood hazard zones. About 80 percent of the structures in the flood plain are residential. Conversations with Pocomoke City residents and local insurance agents indicated that the value of the contents of an average residential structure was about 40 percent of the structure value.

FUTURE GROWTH

Pocomoke City is not subjected to developmental pressures and any changes in Pocomoke City's level of development in the future will be minor. The real value of residential contents was estimated to grow at the OBERS regional growth rate for per capita income for BEA Area 17, which includes Pocomoke City. Per capita income was estimated to grow at an annual rate of 2.6 percent. The value of residential contents, estimated to be 40 percent of structure value, was projected to grow at a rate of 2.6 percent annually until 2005, at which time the content value would equal 75 percent of the structure value. Growth in real value of contents was limited to 75 percent of the structure value. Residential contents would increase 47 percent from 1980 to 1995 with an affluence factor of 1.22.

DAMAGES

A flood damage survey was conducted in Pocomoke City in July 1979. Average annual damages were computed using standard damage-frequency curve and integration techniques. Details and pertinent data for calculating stage-damage and the existing average annual damages of \$25,000 for Pocomoke City are presented in Annex F-III. With the affluence factor analysis, average annual damages increased by less than \$500 and were considered to be negligible. As noted above, little new development is anticipated in this community. However, to test the sensitivity of any plan's feasibility to future development an extreme upper limit on average annual damages was estimated. To do this, it was assumed that the approximate 27 acres of undeveloped land would be immediately developed in a manner reflective of existing development patterns. Damages at and below the 70-year event were not increased but damages above the 100-year event were increased by 16 percent (different percentages reflect increasing flood plain size). Under these extreme assumptions of full development, average annual damages were estimated to be \$27,000.

TABLE F-5
 POCOMOKE CITY FLOOD PLAIN INVENTORY
 (April 1980 Prices)

STAGE (NGVD)	APPROXIMATE FLOOD HAZARD ZONE	NUMBER OF STRUCTURES				AVERAGE ANNUAL DAMAGES
		Residential	Commercial	Industrial	Public & Other	
4 feet	8 year (12%)	2	1	0	0	\$5,000
5 feet	25 year (4%)	16	4	1	0	\$8,000
6 feet	70 year (1.4%)	43	8	1	0	\$12,000
8 feet	500 year (0.20%)	145	30	2	1	\$20,000
18 feet	SPTF	597	103	3	18	\$25,000

WITH PROJECT CONDITIONS

The presence of either a structural or a nonstructural plan of improvement was not expected to influence either the size of the flood plain or the level of development in any way that would differ from without project land use. As a result of providing protection from tidal flooding NED benefits would accrue. The benefits considered are discussed in the following paragraphs and the average annual damage computations for the with project conditions are included in Annex F-III.

Land use is expected to be the same in Pocomoke City with and without a plan and no increased economic activity resulting from a plan is anticipated. There is no potential for intensification benefits in Pocomoke City. For the same reason there is no potential for location benefits. Worcester County, Maryland, has not been designated as an area of "substantial and persistent unemployment" so NED employment benefits were not estimated.

Inundation reduction benefits would accrue to both the structural and nonstructural plans. An affluence factor was computed for the residential content damages. The summary economic analyses of two structural and three nonstructural plans are presented in Table F-6.

In order to test the sensitivity of project feasibility to future development, inundation reduction benefits in Table F-6 were increased by the eight percent increase in average annual damages due to full development in accordance with the assumptions explained above. The benefit-cost ratios for the structural plans were still less than 0.1. Nonstructural plans were not reevaluated because it was assumed that new development would comply with National Flood Insurance floodproofing requirements.

There were no economically justified plans identified for Pocomoke City. Economic justification is insensitive to a more rigorous evaluation of future benefits and there is no realistic potential for unquantifiable EQ benefits.

ROCK HALL, MARYLAND

WITHOUT PROJECT CONDITIONS

Rock Hall is approximately 860 acres in size and is subject to the tidal flooding of the Chesapeake Bay. The community may be subjected to high velocity flooding as a result of the direct assault of waves on development. With the presence of a major Bay harbor in Rock Hall, there is a potential for high debris content in flood waters if boats break loose in a major storm.

The 100-year flood hazard zone (8.7' NGVD) covers about 466 acres of the community. Of this area 57 percent (266 acres) is developed. The 500-year flood hazard zone (11.5' NGVD) covers about 529 acres. Of this amount 68 percent (329 acres) is currently developed.

The Rock Hall flood plain is primarily residential in character with the non-residential development primarily oriented toward the waterfront. Table F-7 summarizes the types of development in the various flood hazard zones. About 90 percent of the structures in

TABLE F-6
 SUMMARY ECONOMIC ANALYSIS OF ALTERNATIVE PLANS
 FOR POCOMOKE CITY
 (April 1980 Prices)
 (\$1,000's)

ITEM	PLAN				
	<u>PC-1</u>	<u>PC-2</u>	<u>PC-3</u>	<u>PC-4</u>	<u>PC-5</u>
Costs					
First Annual	\$ 3,543	\$ 4,323	\$ 260	\$ 729	\$ 1,357
I&A	253	308	19	54	100
O&M	22	27	0	0	0
Total	\$ 275	\$ 335	\$ 19	\$ 54	\$ 100
Benefits					
Intensification	\$ 0	\$ 0	\$ 0	\$ 0	\$ 0
Location	0	0	0	0	0
Employment	0	0	0	0	0
Inundation Reduction					
Existing	11	17	10	14	18
Future*	0	0	0	0	0
Total	\$ 11	\$ 17	\$ 10	\$ 14	\$ 18
Net Benefits	-\$ 264	-\$ 318	-\$ 9	-\$ 40	-\$ 82
Benefit-Cost Ratio	0.0	0.1	0.5	0.3	0.2

*Consists of affluence factor for residential contents only.

TABLE F-7

ROCK HALL FLOOD PLAIN INVENTORY
(April 1980 Prices)

STAGE (NGVD)	APPROXIMATE FLOOD HAZARD ZONE	NUMBER OF STRUCTURES				AVERAGE ANNUAL DAMAGES
		Residential	Commercial	Industrial	Public & Other	
4 feet	8 year (12%)	29	5	1	0	\$3,000
6 feet	25 year (4%)	143	17	6	0	\$17,000
9 feet	140 year (0.7%)	317	22	7	0	\$47,000
12 feet	500 year (0.2%)	423	24	7	1	\$63,000
18 feet	SPTF	613	44	8	8	\$76,000

the flood plain are residential. Based on conversations with Rock Hall residents and local insurance agents the value of the contents of an average residential structure was about 40 percent of the structure value.

FUTURE GROWTH

Rock Hall is not subject to developmental pressures and any changes in Rock Hall's level of development in the future are expected to be minor. Those changes which will take place will be because of, and not in spite of, Rock Hall's proximity to the water. A Federal project consisting of channel deepening and modifications and raising of the breakwaters has caused some expansion within the Rock Hall Harbor. This may have spurred some small increase in support services and residences, but the magnitude is minor.

The real value of residential contents was estimated to grow at the OBERS regional growth rate for per capita income for BEA Area 17, which includes Rock Hall. Per capita income was estimated to grow at an annual rate of 2.6 percent. The value of residential contents, estimated to be 40 percent of structure value, was projected to grow at a rate of 2.6 percent annually until 2005, at which time content value would equal 75 percent of structure value. Growth in real value of contents was limited to 75 percent of structure value. Residential contents would increase by 47 percent from 1980 to 1995 with an affluence factor of 1.22.

DAMAGES

A flood damage survey was conducted in Rock Hall in June 1979. Average annual damages were computed using standard damage-frequency curve and integration techniques. Details and pertinent data for determining stage-damages and the existing average annual damages of \$76,000 for Rock Hall are presented in Annex F-IV.

With the affluence factor analysis, average annual damages increased by \$3,000 to \$79,000. As noted above, little new development is anticipated in this community. However, to test the sensitivity of any plan's feasibility to future development an extreme upper limit on average annual damages was estimated. To do this it was assumed that the approximate 200 acres of undeveloped land would be immediately developed in a manner reflective of existing development patterns. Damages at and below the 100-year flood were increased by 75 percent while damages above the 100-year flood were increased by 60 percent (different percentages reflect increasing flood plain size). Under these extreme assumptions of full development, average annual damages were estimated to be \$127,000.

WITH PROJECT CONDITIONS

The presence of either a structural or a nonstructural plan of improvement would not be expected to influence either the size of the flood plain or the level of development in any way that would differ from the without project land use. As a result of providing protection from tidal flooding NED benefits would accrue. The benefits considered are discussed in the following paragraphs and the average annual damage computations for the with project conditions are included in Annex F-IV.

Land use is expected to be the same in Rock Hall with and without a plan and no increased economic activity resulting from a plan is anticipated. There is no potential for intensification benefits in Rock Hall. For the same reason, there is no potential for location benefits.

Kent County, Maryland, has been designated by the Economic Development Administration, U.S. Department of Commerce as an area of "substantial and persistent unemployment" under sub-section 1 of Title IV of the Public Works and Economic Development Act of 1966. Because sufficient unemployed labor resources are available for employment, all plans would result in NED employment benefits.

Inundation reduction benefits would accrue to both the structural and nonstructural plans. An affluence factor was computed for the residential content damages. The summary economic analyses of six structural and four nonstructural plans are presented in Table F-8.

In order to test the sensitivity of structural project feasibility to future development, inundation reduction benefits in Table F-8 were proportionately increased to \$67,000, \$92,000, \$40,000, \$55,000, \$27,000, and \$37,000, for Plans RH-1 thru RH-6, respectively. The benefit-cost ratios for the structural plans remained at 0.2. Nonstructural plans were not reevaluated because it is assumed that new development would comply with National Flood Insurance Program floodproofing requirements.

There were no economically justified plans identified for Rock Hall. Economic justification is insensitive to a more rigorous evaluation of future benefits and there is no realistic potential for unquantifiable EQ benefits.

SNOW HILL, MARYLAND

WITHOUT PROJECT CONDITIONS

Snow Hill is approximately 750 acres in size and is subject to tidal flooding from the Pocomoke River. The 100-year flood hazard zone (6.5' NGVD) covers about 92 acres of the community. Of this area, 21 percent (19 acres) is developed. The 500-year flood hazard zone (7.8' NGVD) covers about 141 acres. Of this amount 28 percent (39 acres) is developed. The Snow Hill flood plain is primarily non-residential in character. Table F-9 summarizes the type of development in various flood hazard zones. About 45 percent of the structures in flood plains less than the 100-year flood plain are residential.

Based on conversations with Snow Hill residents and local insurance agents the value of the contents of an average residential structure was estimated to be 40 percent of the structure value.

TABLE F-8

SUMMARY ECONOMIC ANALYSIS OF ALTERNATIVE PLANS FOR ROCK HALL
(April 1980 Prices)
(\$1,000's)

ITEM	PLAN									
	RH-1	RH-2	RH-3	RH-4	RH-5	RH-6	RH-7	RH-8	RH-9	RH-10
Costs										
First	\$9,455	\$13,514	\$7,996	\$10,308	\$3,292	\$4,797	\$1,093	\$2,504	\$4,832	\$7,081
Annual										
I&A	674	964	570	735	235	342	81	184	356	521
O&M	58	82	49	63	20	29	0	0	0	0
Total	\$ 732	\$ 1,046	\$ 619	\$ 798	\$ 255	\$ 371	\$ 81	\$ 184	\$ 356	\$ 521
Benefits										
Intensification	\$ 0	\$ 0	\$ 0	\$ 0	\$ 0	\$ 0	\$ 0	\$ 0	\$ 0	\$ 0
Location	0	0	0	0	0	0	0	0	0	0
Employment	97	139	82	106	34	49	11	26	50	73
Inundation Reduction										
Existing	39	53	23	32	15	21	12	24	40	50
Future*	1	2	1	1	1	1	0	1	2	2
Total	\$ 137	\$ 194	\$ 106	\$ 139	\$ 50	\$ 71	\$ 23	\$ 51	\$ 92	\$ 125
Net Benefits	-\$ 595	-\$ 852	-\$ 513	-\$ 659	-\$ 205	-\$ 300	-\$ 58	-\$ 133	-\$ 264	-\$ 396
Benefit-Cost Ratio	0.2	0.2	0.2	0.2	0.2	0.2	0.3	0.3	0.3	0.2

*Consists of affluence factor for residential contents only.

TABLE F-9
 SNOW HILL FLOOD PLAIN INVENTORY
 (April 1980 Prices)

STAGE (NGVD)	APPROXIMATE FLOOD HAZARD ZONE	NUMBER OF STRUCTURES				AVERAGE ANNUAL DAMAGES	
		Residential	Commercial	Industrial	Public & Other		Total
4 feet	8 year (12%)	1	2	0	0	3	\$300
5 feet	25 year (4%)	4	8	1	0	13	\$3,000
6 feet	70 year (1.4%)	13	14	1	0	28	\$5,000
8 feet	500 year (0.20%)	62	22	3	1	88	\$9,000
18 feet	SPTF	414	62	5	14	495	\$11,000

FUTURE GROWTH

Snow Hill is not subject to developmental pressures and any changes in Snow Hill's level of development in the future will be minor. The real value of residential contents was estimated to grow at the OBERS regional growth rate for per capita income for BEA Area 17, which includes Snow Hill. Per capita income was estimated to grow at an annual rate of 2.6 percent. The value of residential contents, estimated to be 40 percent of structure value, was projected to grow at a rate of 2.6 percent annually until 2005, at which time content value would equal 75 percent of structure value. Growth in real value of contents was limited to 75 percent of structure value. Residential contents would increase 47 percent from 1980 to 1995 with an affluence factor of 1.22.

DAMAGES

A flood damage survey was conducted in Snow Hill in July 1979. Average annual damages were computed using standard damage-frequency curve and integration techniques. Details and pertinent data for calculating the stage-damage relationships and the existing average annual damages of \$11,000 are presented in Annex F-V. With the affluence factor analysis, average annual damages increased by less than \$500 and were considered to be negligible. As noted above, little new development is anticipated in this community. However, to test the sensitivity of any plan's feasibility to future development an extreme upper limit on average annual damages was estimated. To do this it was assumed that the approximate 100 acres of undeveloped land within the community would be immediately developed in a manner reflective of existing development patterns. Damages at and below the 100-year flood were increased by 380 percent while damages above the 100-year flood were increased by 260 percent (different percentages reflect increasing flood plain size). Under these extreme assumptions of full development, average annual damages were estimated to be \$37,000.

WITH PROJECT CONDITIONS

The presence of either a structural or a nonstructural plan of improvement would not be expected to influence either the size of the flood plain or the level of development in any way that would differ from without project land use. As a result of providing protection from tidal flooding NED benefits would accrue. The benefits considered are discussed in the following paragraphs and the average annual damage computations for the with project conditions are included in Annex F-V.

Land use is expected to be the same in Snow Hill with and without a plan and no increased economic activity resulting from the plan is anticipated. There is no potential for either intensification or location benefits in Snow Hill. Worcester County, Maryland, has not been designated as an area of "substantial and persistent unemployment" so NED employment benefits are not warranted.

Inundation reduction benefits would accrue to both the structural and nonstructural plans. An affluence factor was computed for the residential content damages but the increase was insignificant. The summary economic analyses of four structural and three nonstructural plans are presented in Table F-10.

TABLE F-10
 SUMMARY ECONOMIC ANALYSIS OF ALTERNATIVE PLANS FOR SNOW HILL
 (April 1980 Prices)
 (\$1,000's)

ITEM	PLAN						
	SH-1	SH-2	SH-3	SH-4	SH-5	SH-6	SH-7
Costs	\$ 3,011	\$ 2,845	\$ 3,742	\$ 3,596	\$ 304	\$ 421	\$ 1,210
First Annual I&A	215	203	267	256	22	38	89
O&M	19	18	23	23	0	0	0
Total	\$ 234	\$ 221	\$ 290	\$ 279	\$ 22	\$ 38	\$ 89
Benefits	\$ 0	\$ 0	\$ 0	\$ 0	\$ 0	\$ 0	\$ 0
Intensification Location	0	0	0	0	0	0	0
Employment Inundation Reduction Existing	5	5	9	8	3	6	8
Future*	0	0	0	0	0	0	0
Total	\$ 5	\$ 5	\$ 9	\$ 8	\$ 3	\$ 6	\$ 8
Net Benefits	-\$ 229	-\$ 216	-\$ 281	-\$ 271	-\$ 19	-\$ 32	-\$ 81
Benefit-Cost Ratio	0.02	0.02	0.03	0.03	0.1	0.2	0.09

*Consists of affluence factor for residential contents only.

In order to test the sensitivity of structural project feasibility to future development, the inundation reduction benefits shown in Table F-10 for Plans SH-1 through SH-4 were proportionately increased to \$16,000, \$16,000, \$29,000 and \$26,000, respectively. With this increase in benefits, the benefit-cost ratios for the structural plans still remained at or less than 0.1. Nonstructural plans were not reevaluated because it was assumed that new development would comply with National Flood Insurance Program floodproofing requirements.

There were no economically justified plans identified for Snow Hill. Economic justification is insensitive to a more rigorous evaluation of future benefits and there is no realistic potential for unquantifiable EQ benefits.

ST. MICHAELS, MARYLAND

WITHOUT PROJECT CONDITIONS

St. Michaels is approximately 620 acres in size and is subject to tidal flooding on the Miles River. The 100-year flood hazard zone (7.2' NGVD) covers about 73 acres of the community. One hundred percent of this area is developed. The 500-year flood hazard zone (9.2' NGVD) covers about 292 acres. Of this amount 76 percent (222 acres) is developed.

The St. Michaels flood plain is primarily residential in character with the non-residential development primarily located on the waterfront and a main commercial street. Table F-11 summarizes the type of development in various flood hazard zones. About 80 percent of the structures in the flood plain are residential. Based on conversations with St. Michaels' residents and local insurance agents the value of the contents of an average residential structure was estimated to be about 40 percent of the structure value.

FUTURE GROWTH

St. Michaels is not subject to strong developmental pressures and any changes which take place will be because of, and not in spite of, St. Michaels proximity to the water. The real value of residential contents was estimated to grow at the OBERS regional growth rate for per capita income for BEA Area 17, which includes St. Michaels. Per capita income was estimated to grow at an annual rate of 2.6 percent. The value of residential contents, estimated to be 40 percent of structure value, was projected to grow at a rate of 2.6 percent annually until 2005, at which time the content value would equal 75 percent of structure value. Growth in real value of contents was limited to 75 percent of structure value. Residential contents would increase 47 percent from 1980 to 1995 with an affluence factor of 1.22.

DAMAGES

A flood damage survey was conducted in St. Michaels in August 1979. Average annual damages were computed using standard damage-frequency curve and integration techniques. Details and pertinent data for calculating the stage-damage relationship and the existing average annual damages are presented in Annex F-VI. With the affluence factor analysis, the average annual damages of \$27,000 increased by less than \$500 and

TABLE F-11

ST. MICHAELS FLOOD PLAIN INVENTORY
(April 1980 Prices)

STAGE (NGVD)	APPROXIMATE FLOOD HAZARD ZONE	NUMBER OF STRUCTURES				AVERAGE ANNUAL DAMAGES
		Residential	Commercial	Industrial	Public & Other	
4 feet	10 year (10%)	1	2	1	0	\$4,000
5 feet	20 year (5%)	3	3	1	0	\$6,000
7 feet	100 year (1%)	55	5	5	2	\$10,000
9 feet	450 year (0.22%)	255	49	6	5	\$17,000
16 feet	SPTF	713	78	10	12	\$27,000

this increase was considered to be negligible. As noted above, little new development is anticipated in this community. However, to test the sensitivity of any plan's feasibility to future development an extreme upper limit on average annual damages was estimated. To do this it was assumed that the approximately 70 acres of undeveloped land within the community would be immediately developed in a manner reflective of existing development patterns. Damages at and below the 100-year flood were not increased but damages above the 100-year flood were increased by 30 percent (different percentages reflect increasing flood plain size). Under these extreme assumptions of full development, average annual damages were estimated to increase by \$5,000 to \$32,000.

WITH PROJECT CONDITIONS

The presence of either a structural or a nonstructural plan of improvement would not be expected to influence either the size of the flood plain or the level of development in any way that would differ from the without project land use. As a result of providing protection from tidal flooding NED benefits would accrue. The benefits considered are discussed in the following paragraphs and the average annual damage computations for the with project conditions are included in Annex F-VI.

Land use is expected to be the same in St. Michaels with and without a plan and no increased economic activity resulting from a plan is anticipated. There was no potential for either intensification or location benefits in St. Michaels. Talbot County, Maryland, has not been designated as an area of "substantial and persistent unemployment" so NED employment benefits were not warranted.

Inundation reduction benefits would accrue to both the structural and nonstructural plans. An affluence factor was computed for the residential content damages. The summary economic analysis of two structural and two nonstructural plans is presented in Table F-12.

In order to test the sensitivity of structural project feasibility to future development, the inundation reduction benefits for plans SM-1 and SM-2 were proportionately increased to \$12,000 and \$20,000, respectively. The benefit-cost ratios for the structural plans remained less than 0.1. Nonstructural plans were not reevaluated because it was assumed that new development would comply with National Flood Insurance Program flood-proofing requirements.

There were no economically justified plans identified for St. Michaels. Economic justification is insensitive to a more rigorous evaluation of future benefits and there is no realistic potential for unquantifiable EQ benefits.

TILGHMAN ISLAND, MARYLAND

WITHOUT PROJECT CONDITIONS

The community of Tilghman is approximately 1,530 acres in size. Tilghman Island is subjected to tidal flooding from the Chesapeake Bay. The community may be subjected to high velocity flooding as a result of the direct assault of waves on development. With the presence of a major Bay harbor and waterfront development in Tilghman, there is the potential for high debris content in flood waters if the boats break loose in a major storm

TABLE F-12
 SUMMARY ECONOMIC ANALYSIS OF ALTERNATIVE PLANS FOR ST. MICHAELS
 (April 1980 Prices)
 (\$1,000s)

ITEM	PLAN			
	SM-1	SM-2	SM-3	SM-4
Costs				
First Annual I&A	\$ 7,224	\$ 11,971	\$ 730	\$ 916
O&M	515 44	854 73	54 0	67 0
Total	\$ 559	\$ 927	\$ 54	\$ 67
Benefits				
Intensification	\$ 0	\$ 0	\$ 0	\$ 0
Location	0	0	0	0
Employment	0	0	0	0
Inundation Reduction				
Existing	10	17	8	11
Future *	0	0	0	0
Total	\$ 10	\$ 17	\$ 8	\$ 11
Net Benefits	-\$ 549	-\$ 910	-\$ 46	-\$ 56
Benefit-Cost Ratio	0.02	0.02	0.1	0.2

*Consists of affluence factor for residential contents only.

or if waterfront property is demolished. The 100-year flood hazard zone (6.1 feet NGVD) covers about 1,108 acres of the community. Of this area 21 percent (236 acres) is developed. The 500-year flood hazard zone (7.9 feet NGVD) covers about 1,397 acres. Of this amount 25 percent (355 acres) is developed.

The Tilghman Island flood plain is primarily residential in character with the non-residential development oriented toward the waterfront. Table F-13 summarizes the type of development in various flood hazard zones. About 90 percent of the structures in the flood plain are residential. The value of the contents of an average residential structure was estimated to be about 40 percent of the structure value.

FUTURE GROWTH

Tilghman Island is not subject to developmental pressures and any changes to Tilghman Island's level of development in the future will be minor. Those changes will take place because of, and not in spite of, Tilghman Island's proximity to the water. The real value of residential contents was estimated to grow at the OBERS regional growth rate for per capita income for BEA Area 17, which includes Tilghman Island. Per capita income growth was estimated to be at an annual rate of 2.6 percent. The value of residential contents, estimated to be 40 percent of the structure value, was projected to grow at a rate of 2.6 percent annually until 2005, at which time content value would equal 75 percent of structure value. Growth in real value of contents was limited to 75 percent of the structure value. Residential contents would increase 47 percent from 1980 to 1995 with an affluence factor of 1.22.

DAMAGES

A flood damage survey was conducted in the community in May 1979. Average annual damages were computed using standard damage-frequency curve and integration techniques. Details and pertinent data for calculating the stage-damage relationship and the existing average annual damages of \$35,000 are presented in Annex F-VII. With the affluence factor analysis, average annual damages increased from \$35,000 to \$36,000. As noted above, little new development is anticipated in this community. However, to test the sensitivity of any plan's feasibility to future development an extreme upper limit on average annual damages was estimated. To do this it was assumed that the approximate 1,042 acres of undeveloped land would be immediately developed in a manner reflective of existing development patterns. Damages at and below the 100-year flood were increased by 370 percent while damages above the 100-year flood were increased by 290 percent (different percentages reflect increasing flood plain size). Under these extreme assumptions of full development, average annual damages were estimated to be \$124,000.

WITH PROJECT CONDITIONS

The presence of either a structural or a nonstructural plan of improvement would not be expected to influence either the size of the flood plain or the level of development in any way that would differ from the without project land use. As a result of providing protection from tidal flooding NED benefits would accrue. The benefits considered are discussed in the following paragraphs and the average damage computations for the with project conditions are included in Annex F-VII.

TABLE F-13
 TILGHMAN ISLAND FLOOD PLAIN INVENTORY
 (April 1980 Prices)

STAGE (NGVD)	APPROXIMATE FLOOD HAZARD ZONE	NUMBER OF STRUCTURES			Public & Other	Total	AVERAGE ANNUAL DAMAGES
		Residential	Commercial	Industrial			
4 feet	15 year (6%)	47	4	2	1	55	\$8,000
5 feet	40 year (2.5%)	99	10	2	1	112	\$15,000
6 feet	90 year (1.1%)	167	11	3	1	182	\$21,000
8 feet	500 year (0.20%)	275	13	3	2	293	\$31,000
15 feet	SPTF	446	22	4	8	480	\$36,000

231

Land use is expected to be the same in Tilghman Island with and without a plan and no increased economic activity resulting from the plan is anticipated. There is no potential for either location or intensification benefits. Talbot County, Maryland, was not designated as an area of "substantial and persistent unemployment" so NED employment benefits were not estimated.

Inundation reduction benefits would accrue to both the structural and nonstructural plans. An affluence factor was computed for the residential content damages. The summary economic analysis of four structural and three nonstructural plans is presented in Table F-14.

In order to test the sensitivity of structural project feasibility to future development, inundation reduction benefits for the structural plans TI-1 through TI-4 were proportionately increased to \$10,000, \$2,000, \$21,000 and \$3,000, respectively. The benefit-cost ratios for the structural plans remained at zero. Nonstructural plans weren't reevaluated because it was assumed that new development would comply with National Flood Insurance Program floodproofing requirements. There were no economically justified plans identified for Tilghman Island. Economic justification is insensitive to a more rigorous evaluation of future benefits and there is no realistic potential for unquantifiable EQ benefits.

VIRGINIA FLOOD-PRONE COMMUNITIES

CAPE CHARLES, VIRGINIA

WITHOUT PROJECT CONDITIONS

Figure F-1 shows the approximate areal extent of flooding which would be experienced during the 100-year and Standard Project tidal floods. Flooded areas shown represent those areas flooded by a rise in water level of surrounding coastal areas. The actual limits of these flooded areas may vary slightly from those shown because of the effects of wave action in exposed areas and also because of the difficulty of locating the exact limits on the ground in such flat terrain. In most cases, the ground level near building foundations has been raised to provide proper drainage, thereby creating isolated spots of high ground which may be above the height of the flood shown. A more accurate estimation of the relative flood hazard can be determined by carrying field survey levels to any point in question.

Practically all of Cape Charles' existing development has taken place on the low ground near the water's edge. Most of the town is below the level of the Standard Project Flood which is an elevation of 12 feet. A field survey performed for this community included an inventory of 538 structures. Of this total, 445 were residential, 85 were commercial, and 8 were public structures. Studies by the Norfolk District indicated that the value of residential contents compared to the value of the structure, averaged from a low of 25 percent to a high of about 40 percent and that lower value homes seemed to have a higher percent of value of contents to structure.

To the south is Cape Charles Harbor, important for commercial fishing vessels and other commerce, while to the north is Kings Creek, a predominantly recreational waterway which is the home port for many charter fishing and hunting vessels. In 1975, an 850-foot

TABLE F-14
SUMMARY ECONOMIC ANALYSIS OF ALTERNATIVE PLANS FOR TILGHMAN ISLAND
(April 1980 Prices)
(\$1,000's)

ITEM	PLAN						
	TI-1	TI-2	TI-3	TI-4	TI-5	TI-6	TI-7
Costs							
First Annual	\$ 7,370	\$ 2,342	\$ 8,896	\$ 2,878	\$ 121	\$ 1,038	\$ 2,772
I&A	526	167	635	205	9	76	204
O&M	45	15	55	18	0	0	0
Total	\$ 571	\$ 182	\$ 690	\$ 223	\$ 9	\$ 76	\$ 204
Benefits							
Intensification	\$ 0	\$ 0	\$ 0	\$ 0	\$ 0	\$ 0	\$ 0
Location	0	0	0	0	0	0	0
Employment	0	0	0	0	0	0	0
Inundation Reduction							
Existing	3	0	6	1	3	14	21
Future*	0	0	0	0	0	0	1
Total	\$ 3	\$ 0	\$ 6	\$ 1	\$ 3	\$ 14	\$ 22
Net Benefits	-\$ 568	-\$ 182	-\$ 684	-\$ 222	-\$ 6	-\$ 62	-\$ 182
Benefit-Cost Ratio	0.0	0.0	0.0	0.0	0.3	0.2	0.1

*Consists of affluence factor for residential contents only.

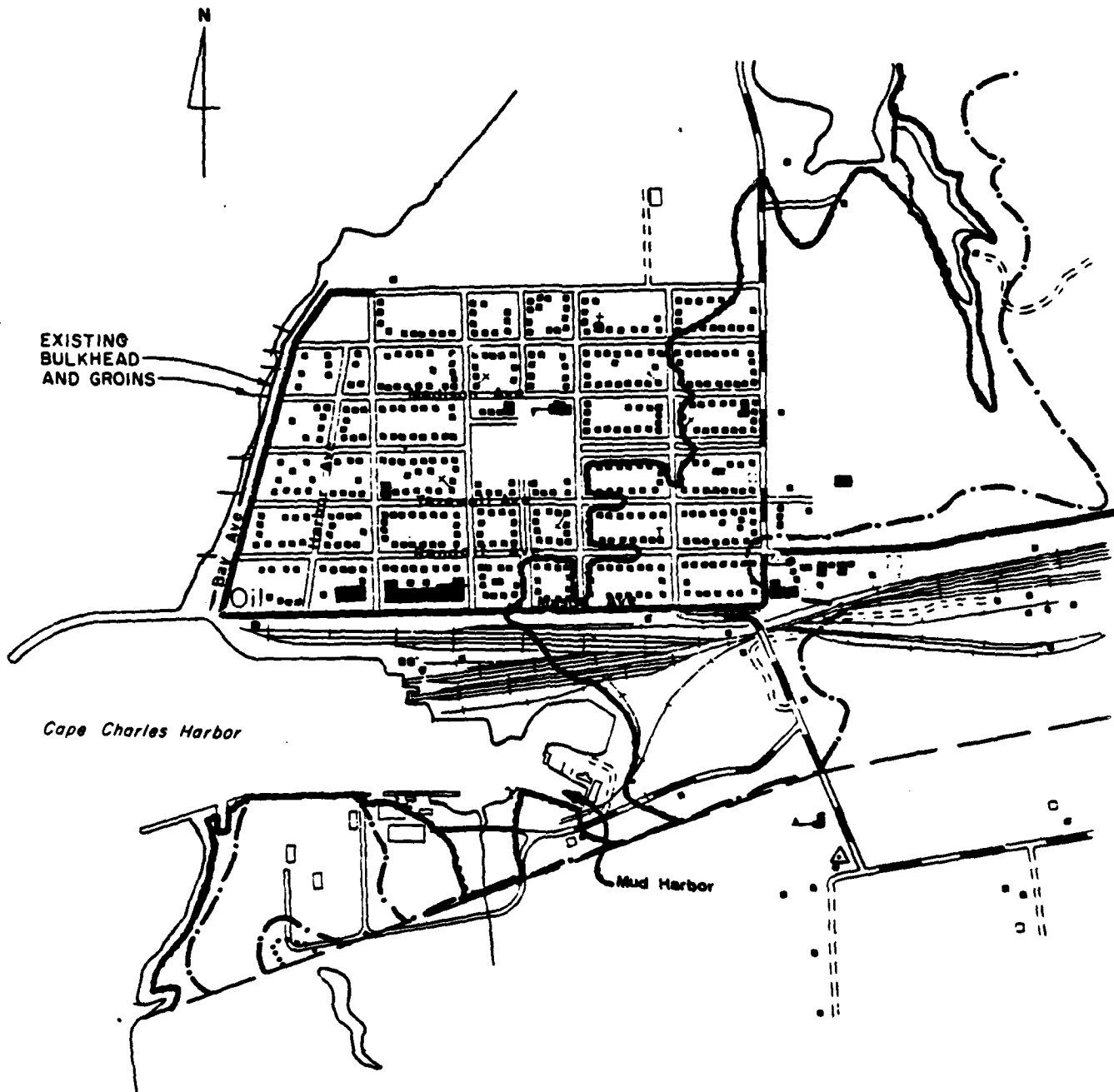

LEGEND

- INTERMEDIATE REGIONAL TIDAL FLOOD (100 YEAR)
- - - - - STANDARD PROJECT TIDAL FLOOD



FIGURE F-1 CAPE CHARLES FLOOD AREA

portion of a city-owned bulkhead around Cape Charles Harbor was reconstructed. There are city-owned piers and four unloading derricks here. Based on data obtained from a visit to the area in 1975, approximately 92 commercial vessels use the harbor each year. Inbound and outbound vessels made 2,308 trips to Cape Charles in 1981. The Virginia-Maryland Railroad Company maintains a line running the length of the Eastern Shore from ports north to Norfolk. Car ferries operate between a railroad in the northern portion of Cape Charles Harbor and Little Creek. The nearest commercial airline service is at the Norfolk Regional Airport near the southern end of the Chesapeake Bay Bridge-Tunnel.

FUTURE GROWTH WITHOUT PROJECT

It is questionable whether any material growth in commercial or industrial property can be expected in the foreseeable future. If Brown and Root had developed an industrial complex in the vicinity of Cape Charles, as it had planned to do, there would have been considerable growth in the community. However, this is not the case. There will undoubtedly be some additional residential development in the area in the foreseeable future. However, in accordance with the Federal Insurance Act and State regulations, the first floor of future houses will have to be raised or flood proofed to elevation 8, the level of the 100-year tidal flood. Any additional commercial development can be accommodated in the existing vacant stores.

STAGE-DAMAGE RELATIONSHIP WITHOUT PROJECT

The probable future damage from tidal flooding was estimated in the following manner. First, a map of the town showing streets and lots was furnished by the mayor. The elevation of street intersections was established in the field based on the available bench marks. Then the first floor elevation of each of the 538 structures was determined. A field inspection of each structure was conducted to establish the elevation of zero damage, type of property (residential, commercial, public), loss and condition of property, number of stories, basement, residential size (small, average, large), furnishings (high, average, low), length and width of commercial property, and its use.

The above information was fed into a computer which contained stage-damage data for different types and classes of property as developed by the Baltimore District, Corps of Engineers. Figure F-2 indicates the stage-damage relationship established for Cape Charles.

The damage-frequency relationship was based on the stage-damage curve compiled for the area, and the stage-frequency curve shown in Appendix E - Engineering Design and Cost Estimates. The potential future flood loss was obtained by multiplying the damages occurring in small increments of stage by the annual expectancy of each increment of stage, and the resulting incremental losses were summarized to determine the total average annual damages up to any tidal flood stage. Table F-15 summarizes the data.

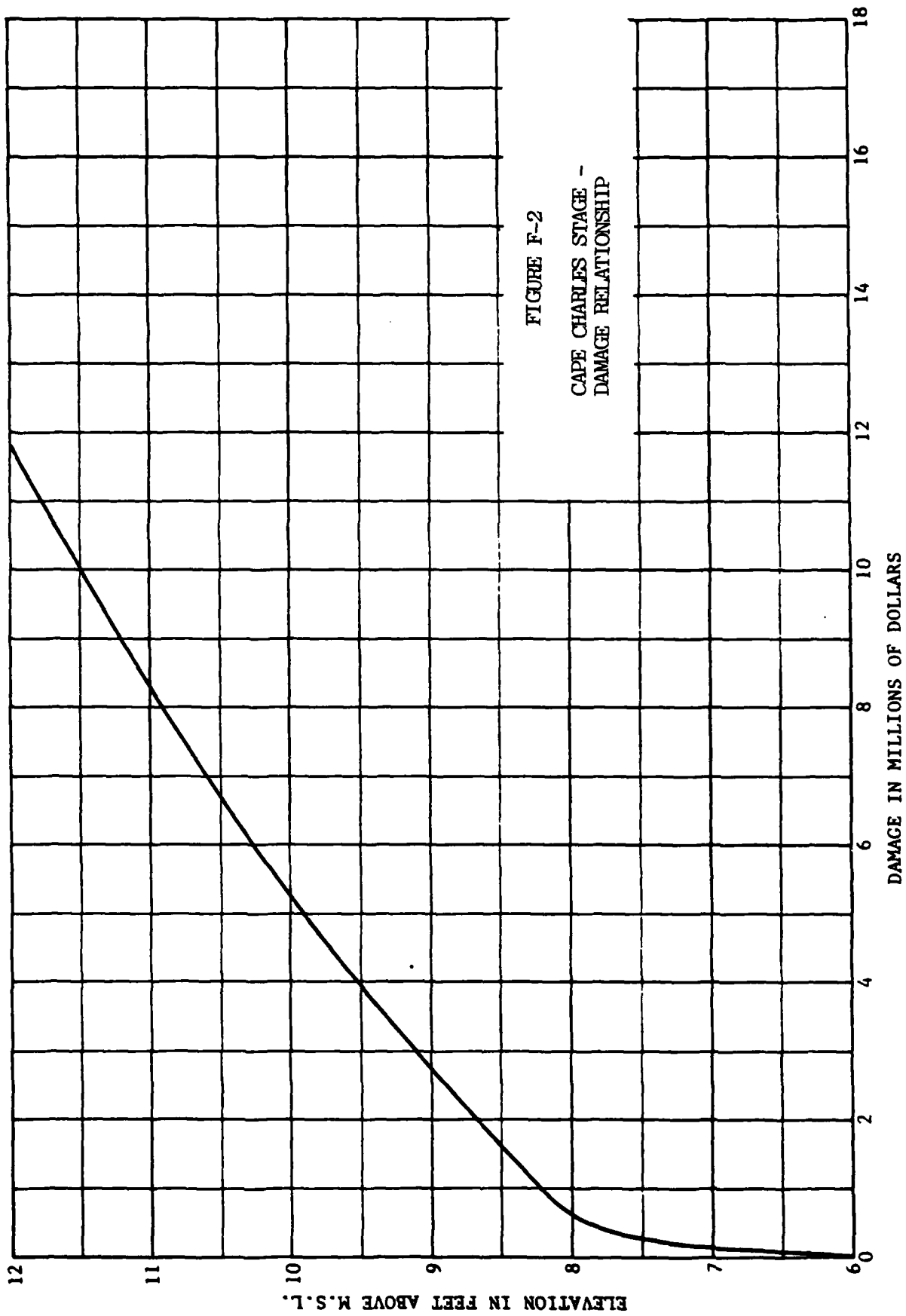

FIGURE F-2
CAPE CHARLES STAGE -
DAMAGE RELATIONSHIP

TABLE F-15

CAPE CHARLES AVERAGE ANNUAL FLOOD DAMAGES
(Based on January 1983 Prices)

<u>TOTAL DAMAGE \$1,000</u>	<u>FLOOD STAGE ELEVATION</u>	<u>PROBABILITY IN YEARS</u>	<u>INTERVAL</u>	<u>AVERAGE INTERVAL</u>	<u>ANNUAL LOSS TO STAGE NOTED</u>
11,753.00	12.00	0.00	0.100	\$ 8,500	\$37,423
5,247.00	10.00	1,000.00	0.233	9,328	28,923
2,748.00	9.00	300.00	0.667	11,193	19,595
610.00	8.00	100.00	1.000	4,240	8,402
238.00	7.40	50.00	0.857	1,581	4,162
131.00	7.00	35.00	2.143	1,832	2,581
40.00	6.50	20.00	3.333	733	748
4.00	6.00	12.00	0.758	\$ 15	15
0.00	5.90	11.00			\$ 0

AFFLUENCE FACTOR BENEFITS

Existing procedures permit the use of growth rates for per capita income as the basis for increasing the real value of residential contents in the future to account for the affluence factor. The value of the residential contents may be projected at the per capita income growth rate to a maximum level of 75 percent of the residential structure. However, because of the low benefit-cost ratio, based on existing conditions, it was not considered necessary to incorporate the affluence factor into the economic analysis for the projects under consideration. It would not influence the benefit-cost ratio over 0.2.

INUNDATION REDUCTION BENEFITS

Flood protection benefits, resulting from raising and/or flood proofing existing buildings, were determined as the differences in the average annual damages under existing conditions and the reduced damages that would result from the proposed nonstructural improvement.

AVERAGE ANNUAL COSTS AND BENEFITS

Table F-16 presents computations of the average annual costs for the nonstructural tidal flood protection plans considered. Table F-17 indicates the average annual benefits of the plans considered while Table F-18 reflects the net benefits attributable to each plan as well as the benefit-cost ratios of the plans.

TABLE F-16

CAPE CHARLES AVERAGE ANNUAL NONSTRUCTURAL COSTS (Based on January 1983 Prices)

Plan	Construction Cost	COST SHARING		Interest (@7-7/8%)	ANNUAL CHARGES		TOTAL
		Federal	Non-Federal		Amortiza- tion at 0.182%	O&M 1%	
A	\$502,000	\$402,000	\$100,000	\$39,500	\$900	\$5,000	\$45,400
B	458,000	366,000	92,000	36,100	800	4,600	41,500
C	127,000	102,000	25,000	10,000	200	1,300	11,500
D	\$103,000	\$ 82,000	\$ 21,000	\$ 8,100	\$200	\$1,000	\$ 9,300

TABLE F-17

CAPE CHARLES AVERAGE ANNUAL NONSTRUCTURAL BENEFITS
(Based on January 1983 Prices)

<u>Plan</u>	<u>Without Project</u>	<u>Following Improvement</u>	<u>Average Annual Benefits</u>
A	\$37,400	\$32,400	\$5,000
B	37,400	32,200	5,200
C	37,400	37,200	200
D	\$37,400	\$37,100	\$300

TABLE F-18

CAPE CHARLES NET NONSTRUCTURAL BENEFITS
(Based on January 1983 Prices)

<u>Plan</u>	<u>Average Annual Cost</u>	<u>Annual Benefits</u>	<u>Net Benefits</u>	<u>Benefit-Cost Ratio</u>
A	\$45,400	\$5,000	-\$ 40,400	0.11
B	41,500	5,200	-36,300	0.13
C	11,500	200	-11,300	0.02
D	\$9,300	\$300	-\$ 9,000	0.03

HAMPTON ROADS, VIRGINIA

WITHOUT PROJECT CONDITIONS

Land for new development is already very scarce in Norfolk and Portsmouth. Chesapeake and Virginia Beach have the largest amount of land available for growth. Chesapeake will probably be the site of many new industrial and residential developments. Chesapeake is actively promoting the former as the 35-foot channel on the Southern Branch of the Elizabeth River was recently extended 1.5 miles upstream, providing 475 additional acres with access to deep water. A Corps feasibility study completed in 1980 recommended the deepening of the existing 35-foot channel between River Mile 15 and 17.5 to a depth of 40 feet over the existing channel width.

The Fox Hill area in Hampton is essentially forested lowland with considerable marshland along the coastline. Of the 1,600 acres in this vicinity, only about 350 acres are developed with about 500 structures. Practically all of these are residential. The commercial establishments are small and housed in old buildings. They consist of a grocery store, two beauty shops, a general contractor, a sign painter, an awning repair shop, a screen printer, and a hide tanner. The value of the contents of residences is about 35 percent of the structure value.

FUTURE GROWTH WITHOUT PROJECT

The large acreage of marshland in this vicinity will remain undeveloped. Undoubtedly, some additional houses will be built in the fringe areas although they will have to be constructed so that the first floor level will be at or above the elevation of the 100-year tidal flood. Whether development of any magnitude will be permitted in the remaining low lying area is questionable. No industry or large commercial enterprise can be expected to develop in this area.

STAGE-DAMAGE RELATIONSHIP WITHOUT PROJECT

A brief study was made of the Fox Hill area of Hampton. This included an examination of available maps, an inspection of the community, and a general field survey. The survey established ground elevations at key points throughout the area and from these the first floor elevation of each structure was determined, as well as the elevation of zero damage. The type of property (residential, commercial, public), class and condition of property, residential size (small, average, large), residential furnishings (low, average, high value), and length, width, use and size of commercial property were also determined for each of the 379 buildings in the area. This information was fed into a computer which contained stage-damage data for different types and classes of property as developed by the Corps.

One area typical of Fox Hill and Hampton Roads was selected for analysis. The data for the 61 structures encompassed by this area were evaluated by the computer and stage-damages were determined for existing conditions. These estimates were updated to January 1983 price levels and are shown in Figure F-3.

The damage-frequency relationship was based on the stage-damage curve compiled for the area, and the stage-frequency curve shown in Appendix E - Engineering Design and Cost Estimates. The potential future flood loss was obtained by multiplying the damage occurring in small increments of stage by the annual expectancy of each increment of stage, and the resulting incremental losses were summed to determine the average annual damage up to any tidal flood stage. Table F-19 indicates the results of this procedure.

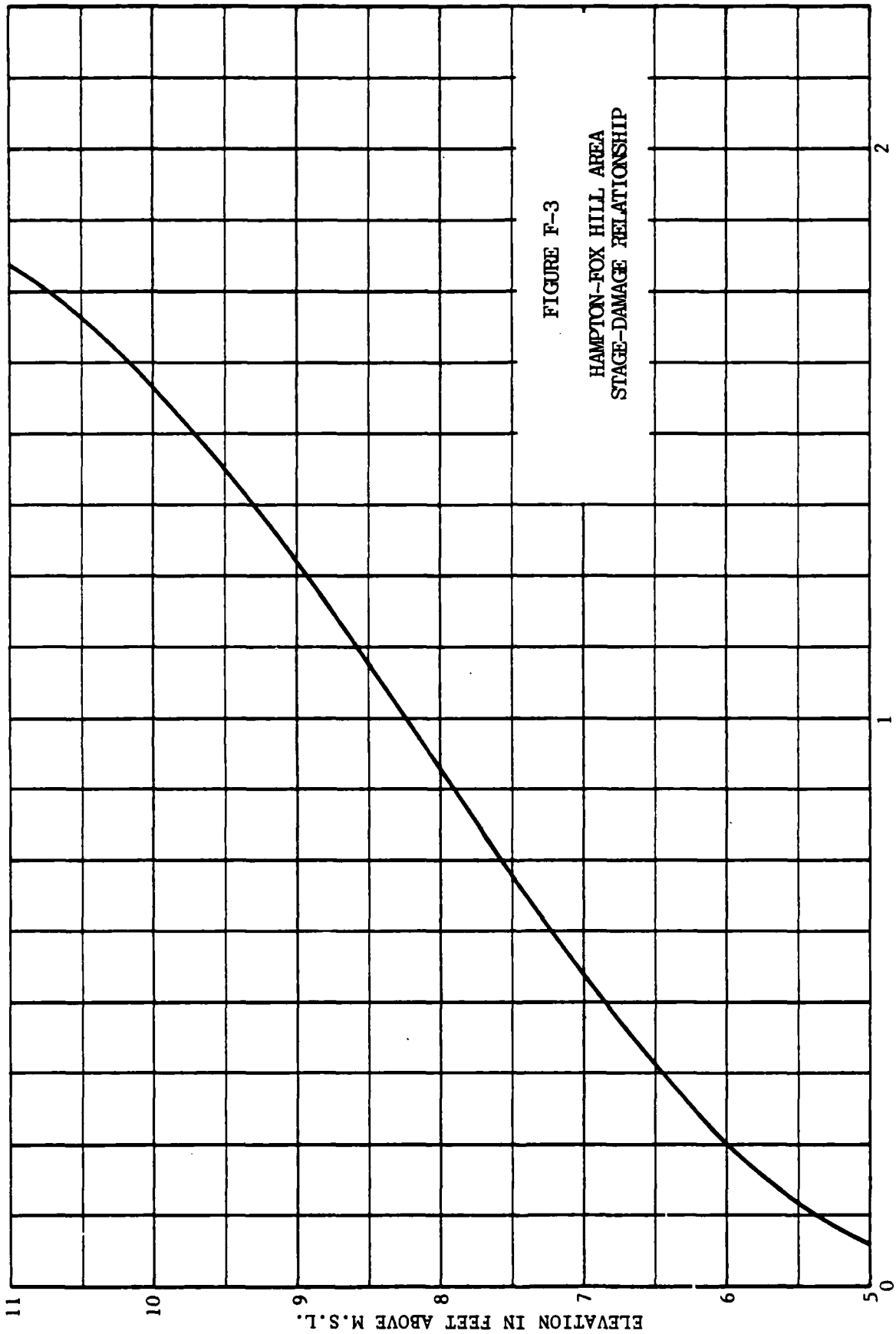

FIGURE F-3
 HAMPTON-FOX HILL AREA
 STAGE-DAMAGE RELATIONSHIP

DAMAGE IN HUNDREDS OF THOUSANDS OF DOLLARS

ELEVATION IN FEET ABOVE M.S.L.

TABLE F-19

HAMPTON-FOX HILL AREA AVERAGE ANNUAL FLOOD DAMAGES
(Based on January 1983 Prices)

<u>TOTAL DAMAGE \$1,000</u>	<u>FLOOD STAGE</u>	<u>PROBABILITY IN YEARS</u>	<u>INTERVAL</u>	<u>AVERAGE INTERVAL</u>	<u>ANNUAL LOSS TO STAGE NOTED</u>
1,805.10	11.00	0.00			\$100,098
1,702.80	10.50	1,000.00	0.100	\$ 1,754	98,344
1,583.80	10.00	600.00	0.067	1,096	97,249
1,532.50	9.80	500.00	0.033	519	96,729
1,271.70	9.00	180.00	0.356	4,985	91,744
1,093.00	8.50	100.00	0.444	5,255	86,489
903.50	8.00	60.00	0.667	6,655	79,834
544.10	7.00	26.00	2.179	15,775	64,059
514.18	6.90	25.00	0.154	815	63,245
256.90	6.00	12.00	4.333	16,720	46,524
75.60	5.00	4.60	13.406	22,287	24,237
3.10	4.00	1.20	61.594	\$24,237	\$ 0

BENEFITS

Existing procedures permit the use of growth rates for per capita income as the basis for increasing the real value of residential contents in the future to account for the affluence factor. The value of the residential contents may be projected at the per capita income growth rate to a maximum level of 75 percent of the value of the residential structure.

For example, in the case of Fox Hill where consideration was given to raising 34 residences up to elevation 6.9', the level of the 25-year flood, the average annual benefits to residential contents increased from \$17,500 to \$29,400 over the next 31 years. The average annual structural benefits of \$32,600 remained the same. Table F-20 shows average annual flood reduction benefits for pertinent years based on the above factors.

Flood protection benefits, resulting from a floodwall or raising existing buildings, were determined as the difference in the average annual damage under existing conditions and the reduced damages that would result from the proposed improvements.

TABLE F-20

HAMPTON RESIDENTIAL FLOOD REDUCTION BENEFITS (Average Annual Dollars Based on January 1983 Prices)

<u>ITEM</u>	<u>100-YEAR PROTECTION</u>	<u>25-YEAR PROTECTION</u>
EXISTING BENEFIT (1983)		
Structure	\$ 57,100	\$32,600
Contents	30,700	17,500
TOTAL	\$ 87,800	\$50,100
BASE YEAR BENEFIT (1988)		
Structure	\$ 57,100	\$ 32,600
Contents	35,100	20,000
TOTAL	\$ 92,200	\$ 52,600
FUTURE BENEFITS-UNDISCOUNTED (2014) ¹		
Structure	\$ 57,100	\$ 32,600
Contents	72,300	41,300
TOTAL	\$129,400	\$ 73,900
AVERAGE ANNUAL BENEFITS		
Structure ²	\$ 57,100	\$ 32,600
Contents	51,500	29,400
TOTAL	\$108,600	\$ 62,000

¹Year in which content value will equal 75 percent of structural value.

²Undiscounted value less base year value multiplied by 0.4408 average annual equivalence factor for 7-7/8 percent, 26 years, and 50-year project life.

The inundation reduction benefits computed for Fox Hill for 59 structures raised to the 100-year flood level and 34 structures raised to the 25-year flood level are \$87,800 and \$50,100, respectively.

AVERAGE ANNUAL COSTS AND BENEFITS

Table F-21 presents computations of average annual costs for the tidal flood protection plans considered while Table F-22 indicates the average annual benefits, net benefits, and benefit-cost ratios for the plans under consideration.

POQUOSON, VIRGINIA

WITHOUT PROJECT CONDITIONS

Poquoson was formerly a rural town dependent on fishing and agriculture. As part of the growing Newport News SMSA, it has now become a residential suburb. Most of the residents are employed at the Newport News Shipyard, National Aeronautics and Space Administration, Langley Air Force Base, and the many commercial and industrial establishments in the Peninsula area. The only job opportunities within Poquoson are in small seafood processing plants, service-type business establishments, and local government agencies.

Residential use totalling approximately 1,900 acres occupies the largest amount of developed land in Poquoson. As of June 1975, there were 1,830 acres in single-family use, 22 acres in mobile homes, 9 in multifamily units, and 1 acre in two-family use. The average size of a single-family residential lot has decreased from 1 acre to approximately 15,000 square feet between 1967 and 1975. This occurred as public water and sewer became available.

Commercial use accounts for approximately 55 acres. Most of these commercial uses are scattered along Poquoson Avenue and Wythe Creek Road. Industrial use occupies approximately 13 acres, an increase of about 9 acres between 1967 and 1975. Public and semi-public uses comprise about 60 acres and include the municipal building, a park, two schools, a fire station, churches, and a sanitary landfill site. Public uses are generally concentrated at two locations—The Southwestern Quadrant of Poquoson and Cedar Roads Intersection and the area between Poplar Road and Freeman Lane. Undeveloped area, covering almost 8,000 acres, makes up between 65-70 percent of the city's land area. Most of the undeveloped area is wetlands and should not be developed for urban uses due to aesthetic and ecological considerations.

Figure F-4 shows the extent of the flood problem in Poquoson. It should be noted that the 25-year tidal flood will cover a substantial portion of the city. The total land area of the city is approximately 15.6 square miles and a considerable portion is marshland. Existing land use is shown in Figure F-5.

TABLE F-21
 HAMPTON AVERAGE ANNUAL COSTS
 (Based on January 1983 Prices)

<u>PLAN</u>	<u>DESCRIPTION</u>	<u>CONSTRUCTION COST (FIRST COST)</u>	<u>FEDERAL SHARE (80%)</u>	<u>LOCAL SHARE (20%)</u>	<u>INTEREST @ 7.875%</u>	<u>AMORTIZATION @ 0.1820%</u>	<u>OPERATION AND MAINTENANCE*</u>	<u>TOTAL</u>
Structural Plan for Protection to 100-year flood level	6,200 feet of floodwall to protect 50 structures to 8.5-foot flood level	\$3,184,000	\$2,547,000	\$637,000	\$250,700	\$5,800	\$95,500	\$352,000
Non-structural Plan for Protection to 100-year flood level	Raise 59 structures to 8.5 feet	\$2,065,000	\$1,652,000	\$413,000	\$162,600	\$3,800	\$20,600	\$187,000
Nonstructural Plan for Protection to 25-year flood level	Raise 34 structures to 6.9 feet	\$904,000	\$723,000	\$181,000	\$71,200	\$1,600	\$9,000	\$81,800

*Structural O&M @ 3%; Nonstructural O&M @ 1%.

TABLE F-22
 HAMPTON AVERAGE ANNUAL BENEFITS
 (Based on January 1983 Prices)

<u>PLAN</u>	<u>DAMAGES</u>		<u>BENEFITS</u>			<u>AVERAGE ANNUAL COSTS</u>	<u>NET BENEFITS</u>	<u>BENEFIT-COST RATIO</u>
	<u>EXISTING CONDITIONS</u>	<u>FOLLOWING IMPROVEMENTS</u>	<u>INUNDATION REDUCTION</u>	<u>AFFLUENCE FACTOR</u>	<u>TOTAL</u>			
Structural plan for protection to 100-year flood level	\$100,100	\$13,600	\$86,500	\$20,400	\$106,900	\$352,000	-\$ 245,100	0.30
Nonstructural plan for protection to 100-year flood level	\$100,100	\$12,300	\$87,800	\$20,800	\$108,600	\$187,000	-\$ 78,400	0.58
Nonstructural plan for protection to 25-year flood level	\$100,100	\$50,000	\$50,100	\$11,900	\$62,000	\$81,800	-\$ 19,800	0.76

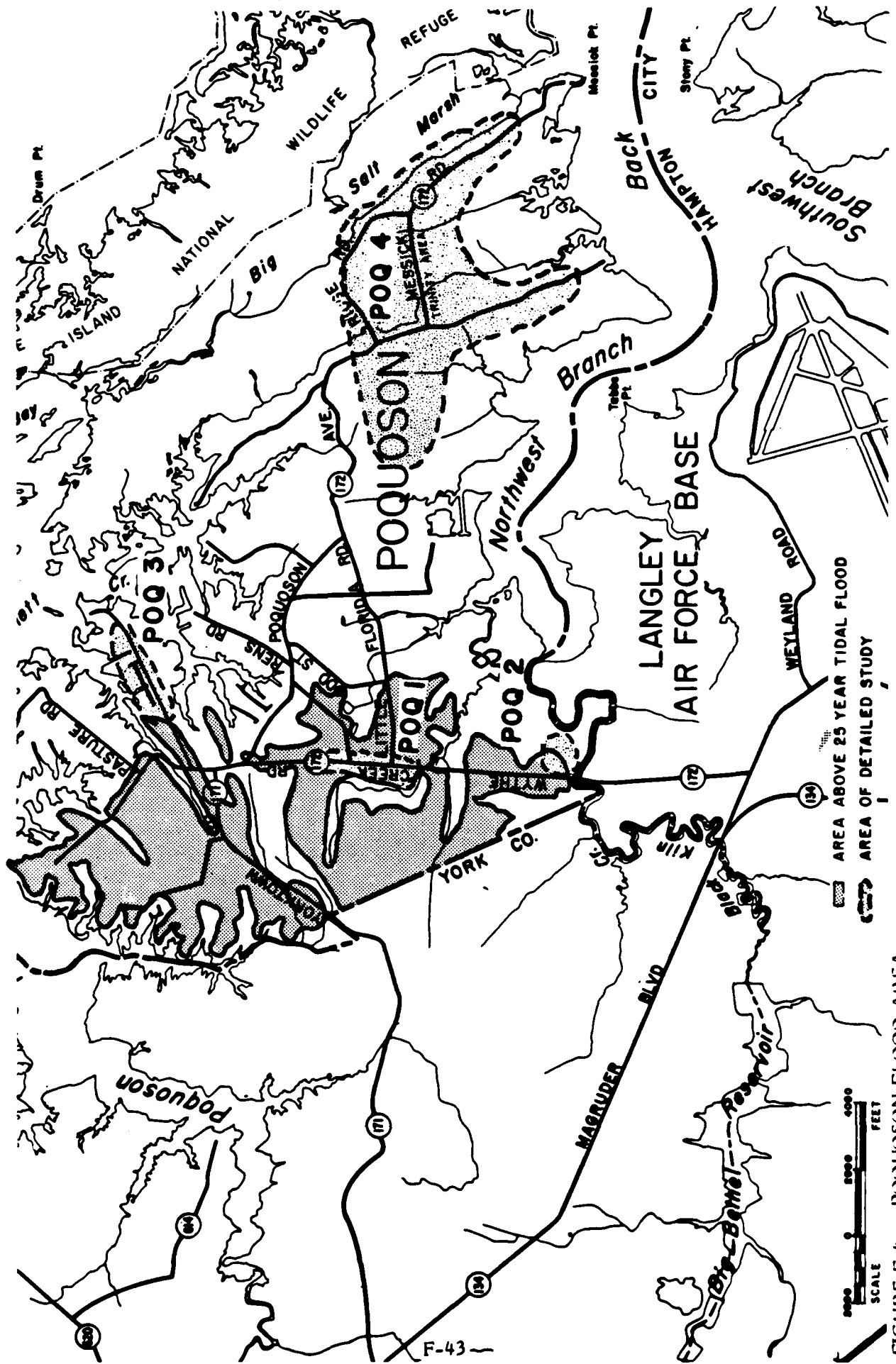
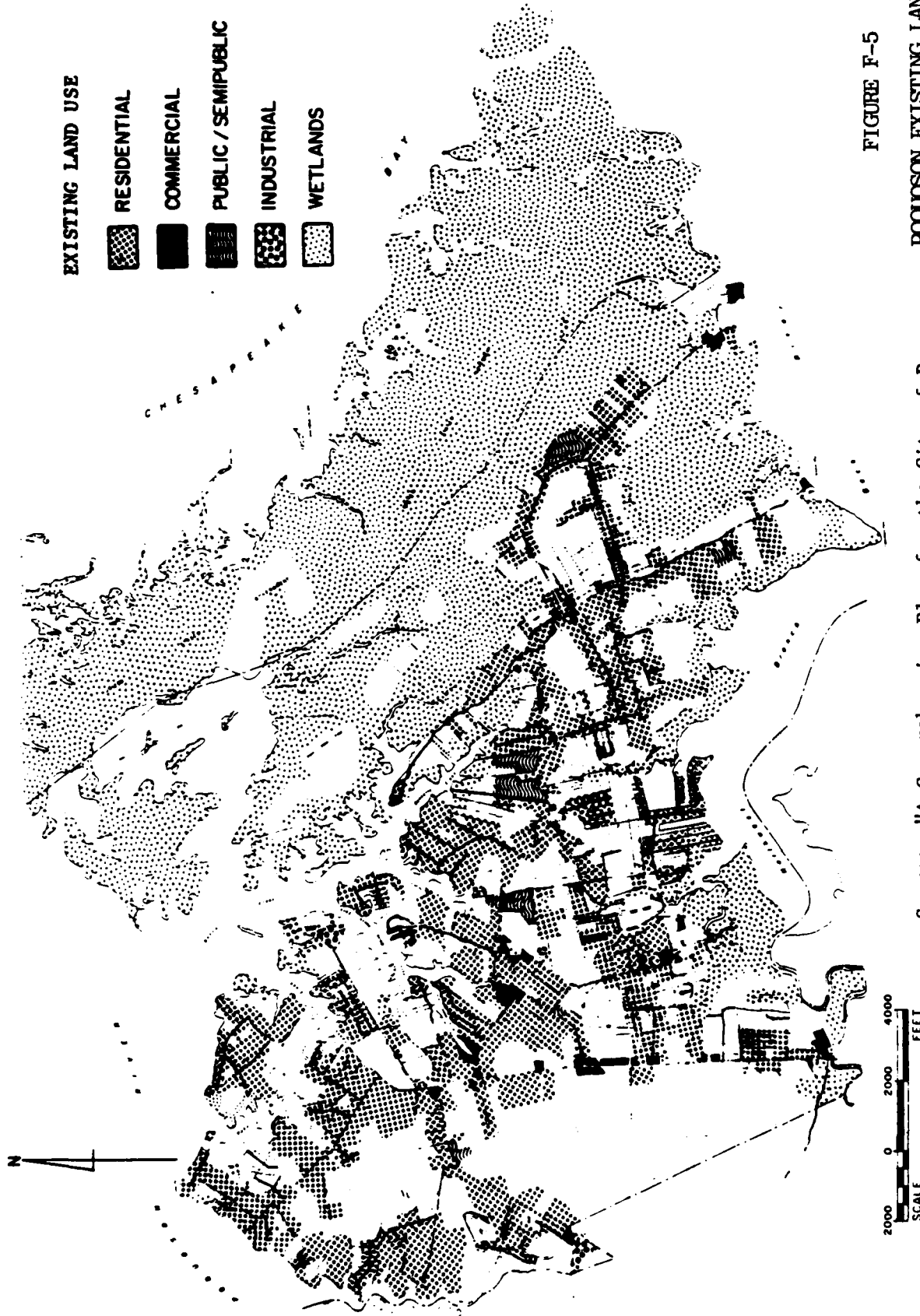

FIGURE F-4 POQUOSON FLOOD AREA



EXISTING LAND USE

RESIDENTIAL

COMMERCIAL

PUBLIC / SEMIPUBLIC

INDUSTRIAL

WETLANDS

FIGURE F-5

Source: "A Comprehensive Plan for the City of Poquoson, Virginia" adopted May 1976.

2000 0 2000 4000
SCALE
FEET

FUTURE GROWTH WITHOUT PROJECT

The economic future of Poquoson is inseparable from that of the entire metropolitan area. This will continue to be the case since Poquoson does not have a strong employment base and must depend on the basic industries of other localities within the SMSA for employment of its residents. Thus, the predominantly suburban residential character of the city is not expected to change.

Figure F-6 shows future (proposed) land use in Poquoson. The approximate acreage for the different residential categories is shown in Table F-23.

TABLE F-23

POQUOSON FUTURE RESIDENTIAL LAND USE

<u>DENSITY CATEGORY</u>	<u>AVERAGE DWELLING UNITS PER ACRE</u>	<u>APPROXIMATE ACREAGE</u>
Low	2	2,000
Low to medium	3	2,500
Medium	4	1,700
High	12	200

SOURCE: Comprehensive Plan adopted May 25, 1976.

Relative to the commercial sector, a medium-size shopping center was recommended for the general business area. Approximately 100 acres are proposed for special waterfront business development including seafood markets and processors, boat repair yards, and marinas.

An industrial park which would comprise 400 acres when fully developed is envisioned for the areas located along both sides of Little Florida Road (between Wythe Creek Road and the Western Corporate Limits). The area is zoned for this development but there are no plans at this time to proceed with development.

Approximately 150 acres of land are proposed for public use, including schools, municipal buildings, sanitary landfill sites, and parks and recreation areas. According to the comprehensive plan, the new high school, the municipal building and the recreation areas which are located between Odd and Cedar Roads should form the center of public activities and services in Poquoson.

STAGE-DAMAGE RELATIONSHIP WITHOUT PROJECT

In 1980, a field survey was made of this community. This included a field investigation, a study of the available maps, and an inspection of the city. The four specific areas previously referred to were delineated and a detailed inventory thereof was made. These areas encompassed 573 structures.

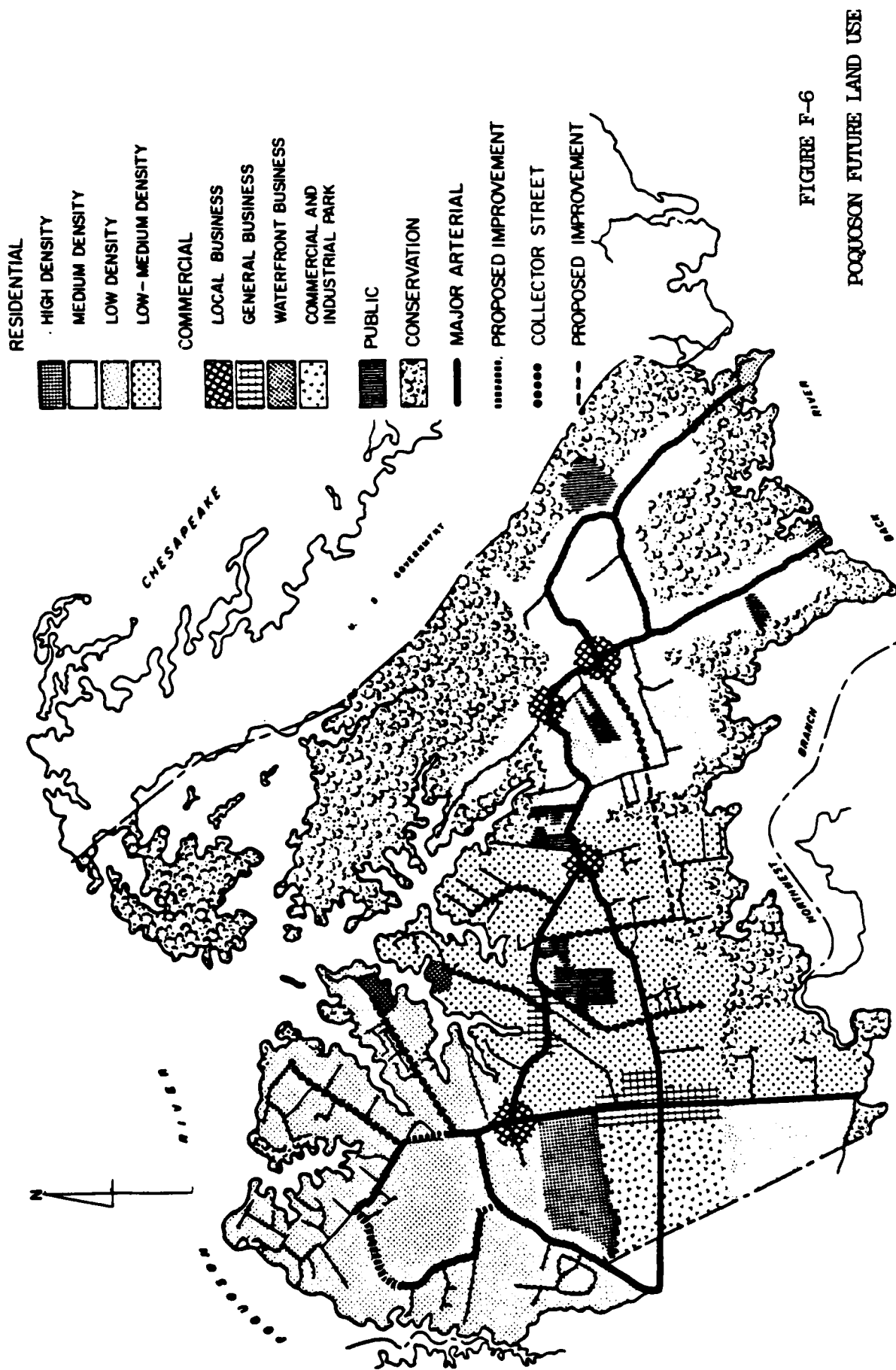

FIGURE F-6

POQUOSON FUTURE LAND USE



Source: "A Comprehensive Plan for the City of Poquoson, Virginia" adopted May 1976.

The first floor elevation of each structure was determined, as well as the elevation of zero damage, type and use of property (residential, commercial, public), class, condition, residential size (small, average, large), furnishings, length, and width. For residential structures, the value of the contents of residences varied from 30 percent for Class A or above average structures to 40 percent for Class C or below average structures.

The above information was fed into a computer which contained stage-damage data for different types and classes of property as developed by the Corps. Figures F-7 through F-10 indicate the resulting stage-damage data for POQ-1 through POQ-4.

The damage-frequency relationship was based on the stage-damage curves compiled for the area and the Corps stage-frequency curve shown in Appendix E - Engineering Design and Cost Estimates. The potential future flood loss was obtained by multiplying the damage occurring in small increments of stage by the annual expectancy of each increment of stage, and the resulting incremental losses were summarized to determine the total average annual damage for any tidal flood stage. Tables F-24 through F-27 indicate the results for the areas investigated.

AFFLUENCE FACTOR BENEFITS

Existing procedures permit the use of growth rates for per capita income as the basis for increasing the real value of residential contents in the future to account for the affluence factor. The value of the residential contents may be projected at the per capita income growth rate to a maximum level of 75 percent of the value of the residential structure. For example, in the case of POQ-4 wherein consideration was given to raising 182 residences up to elevation 7, the level of the 25-year flood, the average annual benefits to residential contents increased from their present amount of \$65,600 to \$105,100 over the next 26 years. The average annual structural benefits of \$118,700 remained the same.

INUNDATION REDUCTION BENEFITS

Flood protection benefits, resulting from purchasing and demolishing and/or raising existing buildings, were determined as the difference in the average annual damage under existing conditions and the reduced damages that would result from the proposed nonstructural improvement. The inundation reduction benefits computed for the various areas are shown in Table F-28.

AVERAGE ANNUAL COSTS AND BENEFITS

Table F-29 presents computations of the average annual costs for the nonstructural tidal flood protection plans considered while Table F-30 presents the average annual benefits determined for the plans examined. Table F-31 indicates the net benefits attributable to each plan as well as the benefit-cost ratio.

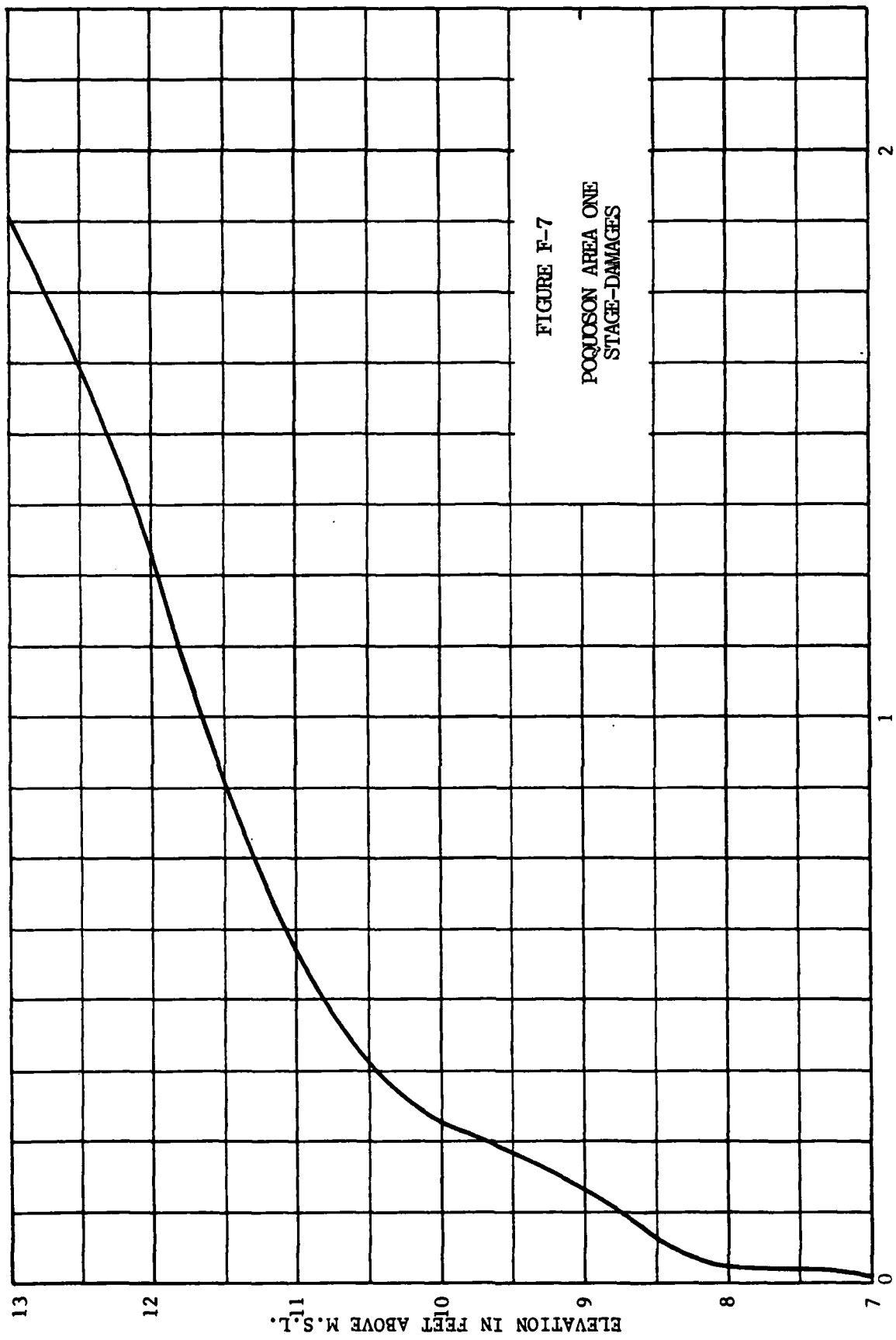

FIGURE F-7
POQUOSON AREA ONE
STAGE-DAMAGES

DAMAGE IN MILLIONS OF DOLLARS

ELEVATION IN FEET ABOVE M.S.L.

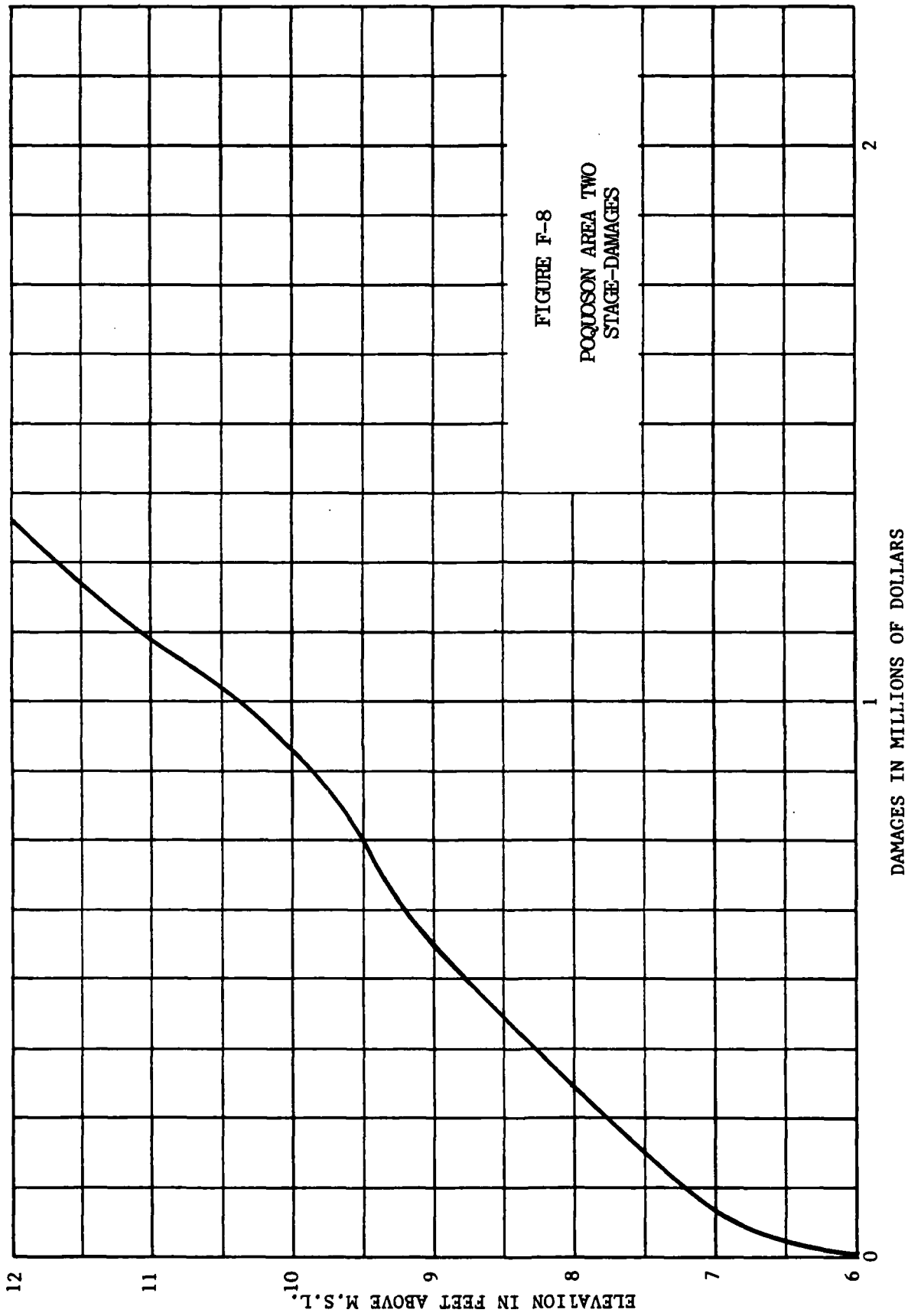
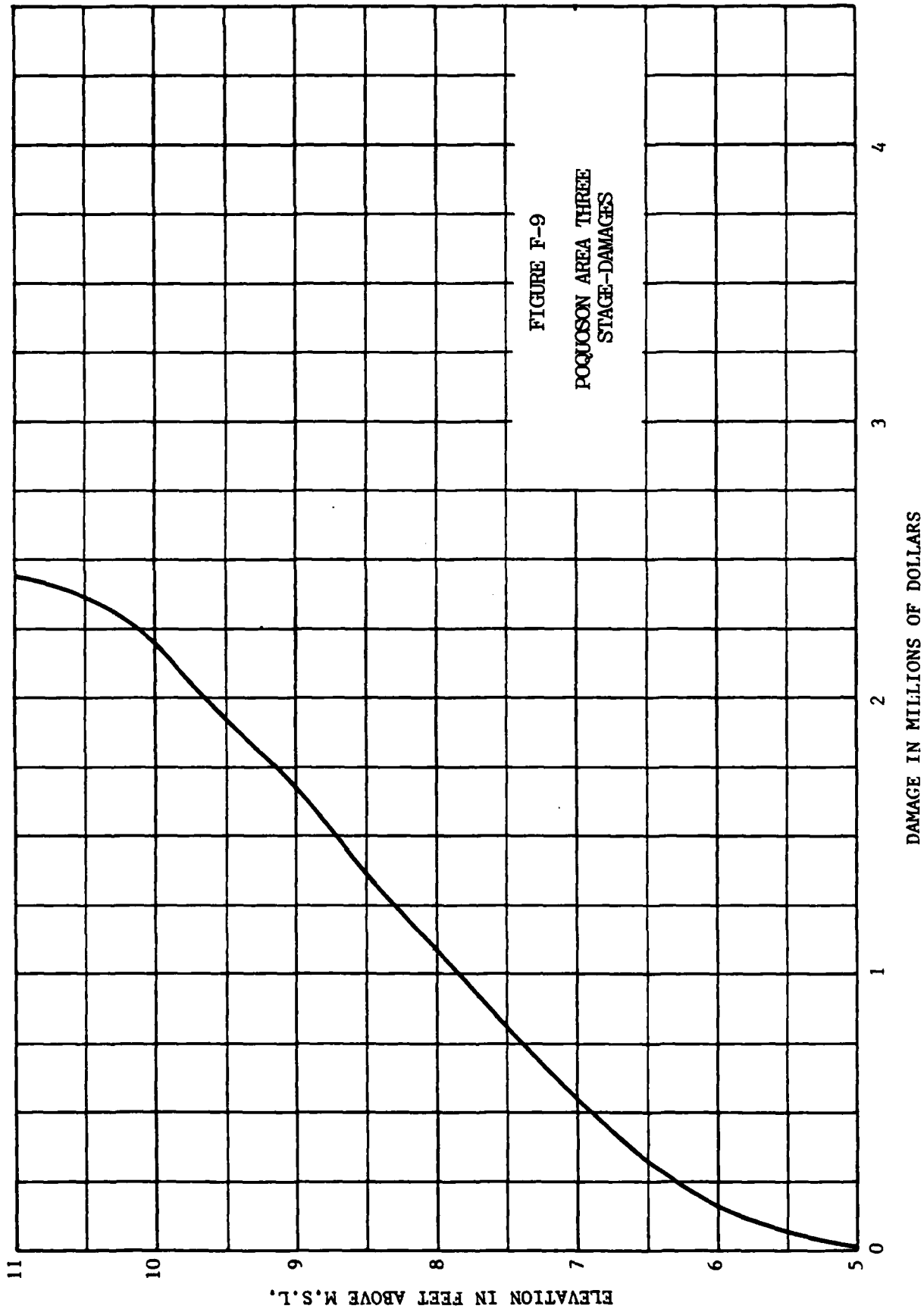

FIGURE F-8
POQUOSON AREA TWO
STAGE-DAMAGES



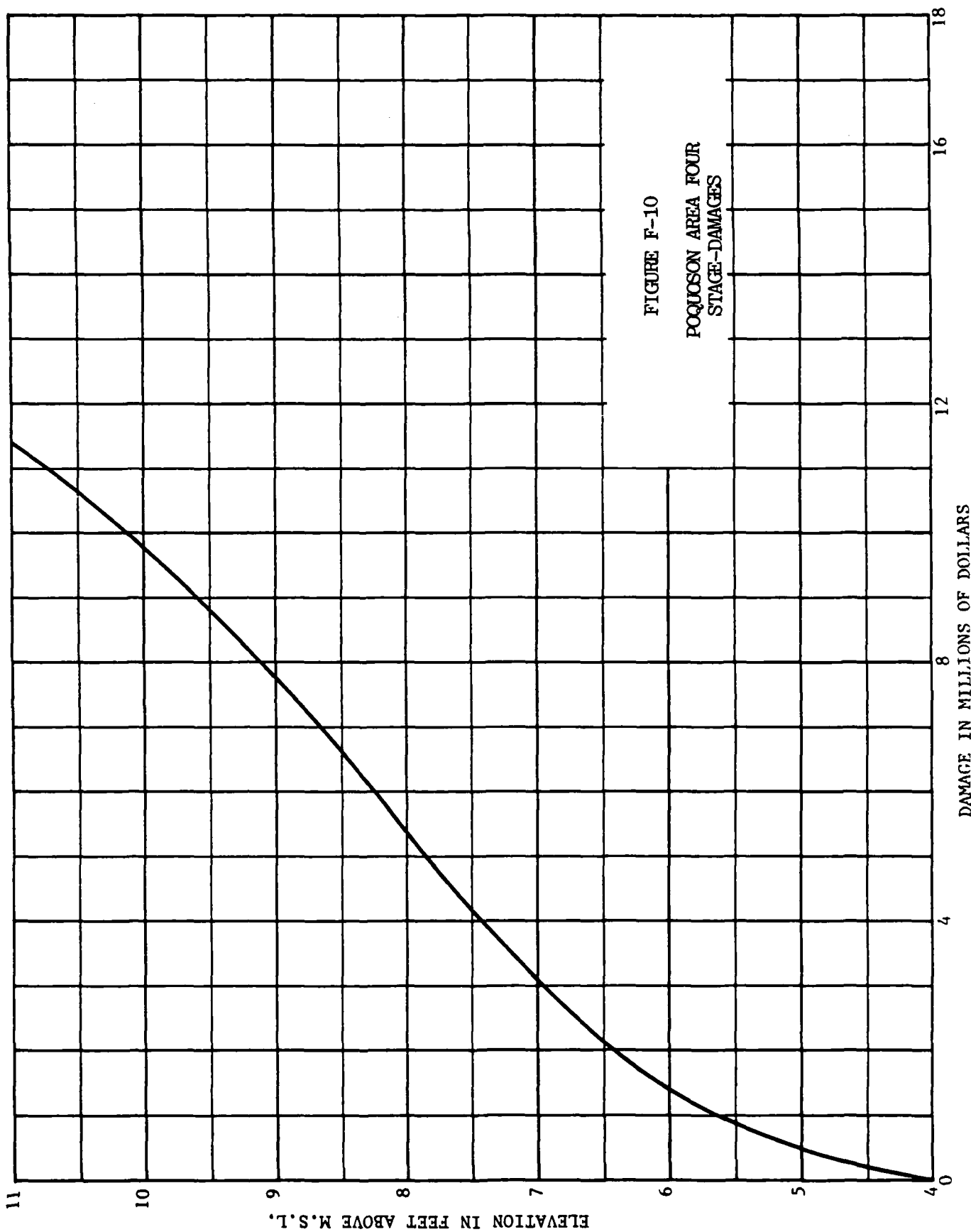

FIGURE F-10
POQUOSON AREA FOUR
STAGE-DAMAGES

TABLE F-24

POQUOSON AREA ONE
 AVERAGE ANNUAL FLOOD DAMAGES
 (Based on January 1983 Prices)

<u>TOTAL DAMAGE \$1,000</u>	<u>FLOOD STAGE</u>	<u>PROBABILITY IN YEARS</u>	<u>INTERVAL</u>	<u>AVERAGE INTERVAL</u>	<u>ANNUAL LOSS TO STAGE NOTED</u>
588.10	11.00	0.00			\$3,258
278.80	10.00	1,000.00	0.100	\$433	2,824
257.40	9.80	500.00	0.100	268	2,556
167.10	9.00	175.00	0.371	788	1,768
79.20	8.50	100.00	0.429	528	1,240
27.30	8.00	60.00	0.667	355	885
17.00	7.00	25.00	2.333	517	368
0.00	6.00	12.00	4.333	\$368	\$ 0

TABLE F-25

POQUOSON AREA TWO
 AVERAGE ANNUAL FLOOD DAMAGES
 (Based on January 1983 Prices)

<u>TOTAL DAMAGE \$1,000</u>	<u>FLOOD STAGE</u>	<u>PROBABILITY IN YEARS</u>	<u>INTERVAL</u>	<u>AVERAGE INTERVAL</u>	<u>ANNUAL LOSS TO STAGE NOTED</u>
1,112.80	11.00	0.00			\$15,021
867.60	10.00	1,000.00	0.100	\$ 990	14,030
782.10	9.80	500.00	0.100	825	13,206
563.10	9.00	175.00	0.371	2,498	10,707
415.80	8.50	100.00	0.429	2,098	8,610
280.80	8.00	60.00	0.667	2,322	6,288
80.00	7.00	25.00	2.333	4,209	2,078
11.50	6.00	12.00	4.333	1,983	96
0	5.80	10.00	1.667	\$ 96	\$ 0

TABLE F-26

POQUOSON AREA THREE
 AVERAGE ANNUAL FLOOD DAMAGES
 (Based on January 1983 Prices)

<u>TOTAL DAMAGE \$1,000</u>	<u>FLOOD STAGE</u>	<u>PROBABILITY IN YEARS</u>	<u>INTERVAL</u>	<u>AVERAGE INTERVAL</u>	<u>ANNUAL LOSS TO STAGE NOTED</u>
2,437.80	11.00	0.00			\$ 66,477
			0.100	\$ 2,290	
2,142.80	10.00	1,000.00			64,187
			0.100	2,111	
2,079.00	9.80	500.00			62,076
			0.371	6,956	
1,666.80	9.00	175.00			55,119
			0.429	6,499	
1,366.20	8.50	100.00			48,620
			0.667	8,156	
1,080.70	8.00	60.00			40,464
			2.333	19,100	
556.40	7.00	25.00			21,364
			4.333	15,204	
145.30	6.00	12.00			6,161
			1.667	2,201	
118.80	5.80	10.00			3,960
			6.667	\$ 3,960	
0.00	5.00	6.00			\$ 0

TABLE F-27

POQUOSON AREA FOUR
 AVERAGE ANNUAL FLOOD DAMAGES
 (Based on January 1983 Prices)

<u>TOTAL DAMAGE \$1,000</u>	<u>FLOOD STAGE</u>	<u>PROBABILITY IN YEARS</u>	<u>INTERVAL</u>	<u>AVERAGE INTERVAL</u>	<u>ANNUAL LOSS TO STAGE NOTED</u>
11,287.60	11.00	0.00			\$ 416,631
9,814.50	10.00	1,000.00	0.100	\$ 10,551	406,080
9,306.00	9.80	500.00	0.100	9,560	396,519
7,732.70	9.00	175.00	0.371	31,643	364,876
6,633.00	8.50	100.00	0.429	30,784	334,092
5,380.80	8.00	60.00	0.667	40,046	294,046
3,107.40	7.00	25.00	2.333	99,029	195,017
1,403.40	6.00	12.00	4.333	97,734	97,283
425.30	5.00	6.00	8.333	76,196	21,087
20.20	4.00	4.00	8.333	18,562	2,525
0.00	3.00	2.00	25.000	\$ 2,525	\$ 0

TABLE F-28

POQUOSON INUNDATION REDUCTION BENEFITS
 (Based on January 1983 Prices)

<u>AREA</u>	<u>PLAN</u>	<u>INUNDATION REDUCTION BENEFITS</u>
POQ-1*	--	-
POQ-2	Relocate 96 trailers	\$ 15,000
POQ-3	Raise 45 structures to 100-year flood level	39,200
POQ-3	Raise 9 structures to 25-year flood level	17,600
POQ-4	Raise 383 structures to 100-year flood level	362,000
POQ-4	Raise 182 structures to 25-year flood level	184,300
POQ-4	Raise 124 structures to 25-year flood level and purchase and demolish 58 structures	208,500
POQ-4	Purchase and demolish 25 structures below 10-year flood level	\$ 27,800

*No improvement considered.

TABLE F-29
 POQUOSON AVERAGE ANNUAL NONSTRUCTURAL COSTS
 (Based on January 1983 Prices)

PLAN AREA	LEVEL OF PROTECTION	ELEVATION	CONSTRUCTION COST	FEDERAL SHARE	LOCAL SHARE	INTEREST @ 7-7/8%	AMORTIZATION @ 0.182%	OPERATION AND MAINTENANCE @ 1%	TOTAL ANNUAL COSTS
POQ-2	Complete	-	\$792,000	\$634,000	\$158,000	\$62,400	\$1,400	\$7,900	\$71,700
POQ-3	100-year	8.5	1,008,000	806,000	202,000	79,400	1,800	10,100	91,300
POQ-3	25-year	7.0	199,000	159,000	40,000	15,700	400	2,000	18,100
POQ-4	100-year	8.5	8,754,000	7,003,000	1,751,000	689,400	15,900	87,500	792,800
POQ-4	25-year	7.0	3,902,000	3,122,000	780,000	307,300	7,100	39,000	353,400
POQ-4 ¹	25-year	7.0	5,127,000	4,102,000	1,025,000	322,500	7,400	51,300	381,200 ²
POQ-4 ³	10-year	5.8	\$978,000	\$782,000	\$196,000	\$42,000	\$1,000	\$9,800	\$52,800 ²

¹ Purchase and demolish 58 structures. Raise 124 structures.

² Excludes interest and amortization on cost of resettlement.

³ Purchase and demolish 25 structures.

NOTE: Costs are computed based on a 50-year project life.

TABLE F-30

POQUOSON AVERAGE ANNUAL NONSTRUCTURAL BENEFITS
(Based on January 1983 Prices)

<u>Area</u>	<u>Plan Considered</u>	<u>AVERAGE ANNUAL DAMAGE</u>		<u>AVERAGE ANNUAL BENEFITS</u>		
		<u>Naturally</u>	<u>Following improvement</u>	<u>Inundation reduction</u>	<u>Affluence factor¹</u>	<u>Total</u>
POQ-2	Complete relocation	\$15,000	\$ 0	\$15,000	-	\$15,000
POQ-3	100-year flood level	66,500	27,300	39,200	-	39,200
POQ-3	25-year flood level	66,500	48,900	17,600	\$ 3,700	21,300
POQ-4	100-year flood level	416,600	54,600	362,000	-	362,000
POQ-4	25-year flood level	416,600	232,300	184,300	\$39,500	223,800
POQ-4	25-year flood level ²	416,600	208,100	208,500	\$44,700	253,200
POQ-4	10-year flood level ³	\$416,600	\$388,800	\$27,800	-	\$27,800

¹Not determined in all cases. B-C ratio considerably less than 1.0.

²Purchase and demolish structures. Raise others.

³Purchase and demolish structures.

TABLE F-31

POQUOSON NET NONSTRUCTURAL BENEFITS AND B-C RATIOS
(Based on January 1983 Prices)

<u>PLAN AREA</u>	<u>PLAN CONSIDERED</u>	<u>ANNUAL COSTS</u>	<u>AVERAGE ANNUAL BENEFITS</u>	<u>NET BENEFITS</u>	<u>BENEFIT-COST RATIO</u>
POQ-2	Complete relocation	\$71,700	\$15,000	-\$56,700	0.21
POQ-3	100-year flood level	91,300	39,200	-52,100	0.43
POQ-3	25-year flood level	18,100	21,300	3,200	1.18
POQ-4	100-year flood level	792,800	362,000	-430,800	0.46
POQ-4	25-year flood level	353,400	223,800	-129,600	0.63
POQ-4 ¹	25-year flood level	381,200	253,200	-128,000	0.66
POQ-4 ²	10-year flood level	\$52,800	\$27,800	-\$25,000	0.53

¹Purchase and demolish structures. Raise others.

²Purchase and demolish structures.

TANGIER ISLAND, VIRGINIA

WITHOUT PROJECT CONDITIONS

Tangier Island is susceptible to tidal flooding — the extent depending on the level of the stillwater stage. Based on Corps frequency data, the 100-year tidal flood of elevation 8.5' would inundate the entire island and all the structures would be damaged to a degree. Damage would exceed \$1.3 million to residential and commercial property. Based on VIMS frequency data, the 100-year tidal flood elevation of 4.1' would cause damage approaching \$68,000. Under the Corps frequency data, an extremely rare storm, exceeding the 100-year tidal flood, would create a serious tidal flood problem on the island. The lives of some of the islanders would be threatened and 298 residential, 25 commercial, and 7 public units would receive major damage.

FUTURE GROWTH WITHOUT PROJECT

It is anticipated that there will be little growth on the island. All available land is occupied. There appears to be sufficient space for present inhabitants, however future generations will find it difficult to expand on the considerable amount of available marshland unless restrictions on filling this land are lifted. At present, this does not appear likely.

Businesses will have the same difficulty as the inhabitants in locating additional land area for expansion. The main industry is fishing and Tangier's economy is directly dependent on this source of income.

STAGE-DAMAGE RELATIONSHIP WITHOUT PROJECT

The stage-damage relationship was established for the structures on Tangier Island. First-floor elevations of the 331 structures were determined by field survey. A field inspection of each structure was conducted to establish the elevation of zero damage, type of property (residential, commercial, public), class and condition of property, number of stories, existence of basement, residential size (small, average, large), class of furnishings (high, average, low), length and width of commercial property and its use. This information was fed into a computer which contained stage-damage data for different types and classes of property as developed by the Corps of Engineers. Figure F-11 indicates the stage-damage relationship established for Tangier.

The damage-frequency relationship was based on the stage-damage curve computed for the area and the stage-frequency curves shown in Appendix E - Engineering Design and Cost Estimates. The potential future flood loss was obtained by multiplying the damages occurring in small increments of stage by the annual expectancy of each increment of stage. The resulting incremental losses were summed to determine the total average annual damages up to any tidal flood stage. Table F-32 summarizes the data.

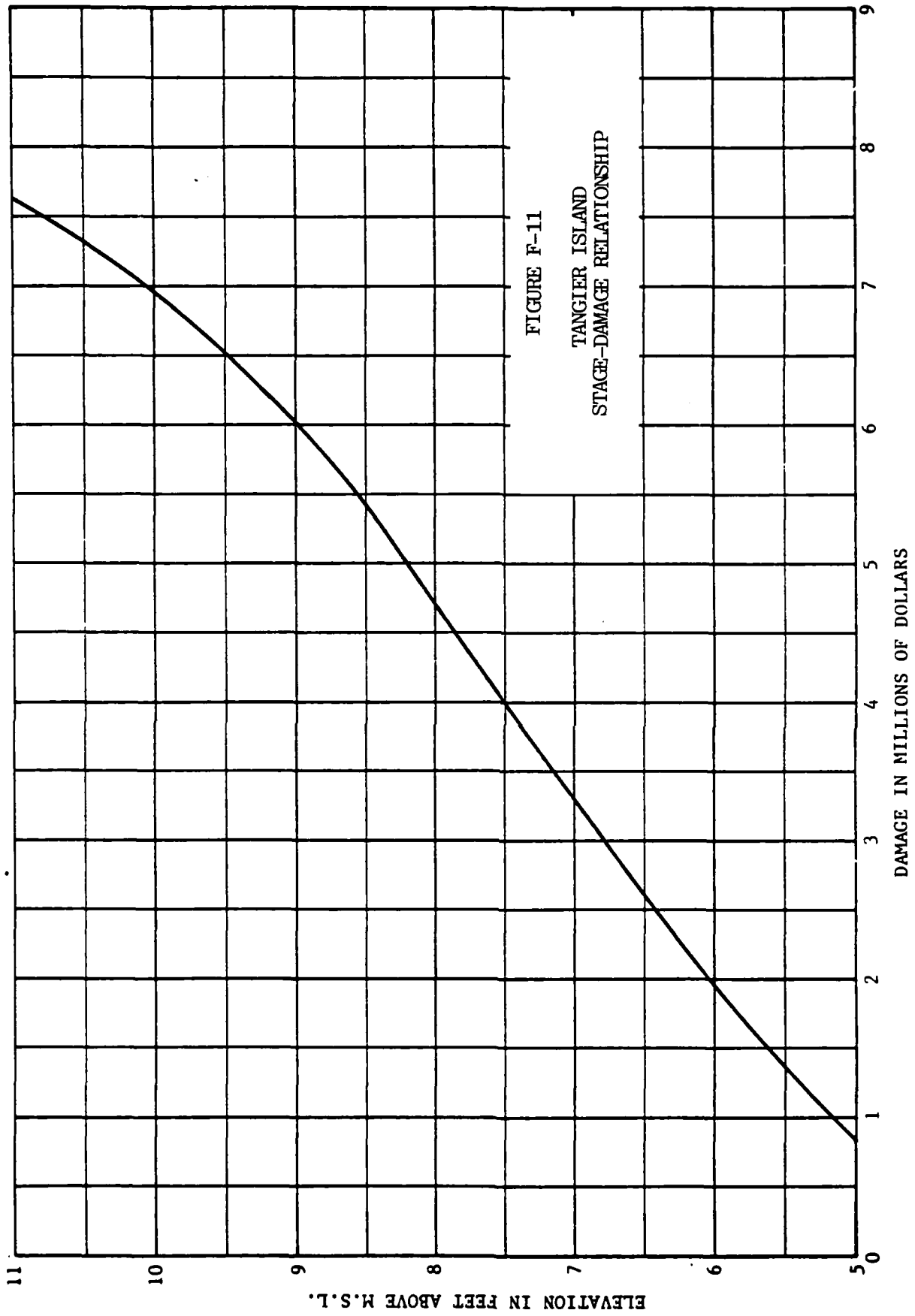

FIGURE F-11
TANGIER ISLAND
STAGE-DAMAGE RELATIONSHIP

TABLE F-32

TIDAL STAGE-DAMAGE DATA FOR TANGIER*
(Corps of Engineers Frequencies)

<u>TOTAL DAMAGE \$1,000</u>	<u>FLOOD STAGE</u>	<u>PROBABILITY IN YEARS</u>	<u>INTERVAL</u>	<u>AVERAGE INTERVAL</u>	<u>ANNUAL LOSS TO STAGE NOTED</u>
7,643.00	11.00	0.00			\$ 481,734
6,978.00	10.00	1,000.00	0.100	\$ 7,310	474,423
6,811.00	9.80	500.00	0.100	6,894	467,529
6,023.00	9.00	175.00	0.371	23,835	443,694
5,445.00	8.50	100.00	0.429	24,574	419,120
4,708.00	8.00	60.00	0.667	33,843	385,277
3,315.00	7.00	25.00	2.333	93,602	291,675
1,940.00	6.00	12.00	4.333	113,858	177,817
1,683.00	5.80	10.00	1.667	30,192	147,625
847.00	5.00	6.00	6.667	84,333	63,292
246.00	4.00	4.00	8.333	45,542	17,750
28.00	3.00	3.00	8.333	11,417	6,333
12.00	2.00	2.00	16.667	3,333	3,000
0.00	1.00	1.00	50.00	\$ 3,000	\$ 0

*Based on January 1983 price levels.

AFFLUENCE FACTOR BENEFITS

Existing procedures permit the use of per capita income growth rates as the basis to increase the real value of residential contents in the future to account for the affluence factor. The residential units on Tangier are middle class homes of the \$10,000 to \$25,000 range. The value of the contents was assumed to be 40 and 35 percent, respectively.

The value of the residential contents may be projected at the per capita income growth rate to a maximum level of 75 percent of the value of the residential structure. Table F-33 shows projected per capita income for the period 1970 - 2020 for BEA Economic Area 017 which includes Tangier.

TABLE F-33
PER CAPITA INCOME, BEA ECONOMIC AREA 017

<u>YEAR</u>	<u>AMOUNT (1967 \$)</u>
1970	3,570
1980	4,800
1990	6,200
2000	8,200
2020	13,400

INUNDATION REDUCTION BENEFITS

Flood protection by walls is positive up to the height of this type of protection. The average annual benefits to be derived from building a wall or berm were taken as the average annual damages eliminated from floods up to the stage that would be controlled, exclusive of freeboard.

Based on the per capita income estimates and the 75 percent of structure value maximum limitation, projections were made for the 25-year and the 100-year event for Corps frequency data. By using the above data, content values in residential structures increased from \$7,200 at present to \$14,700 in 2009. Table F-34 shows average annual flood reduction benefits for pertinent years based on the above discussion for the 100-year Corps frequency plan.

Flood protection benefits, resulting from raising and/or flood proofing existing buildings, were determined as the difference in the average annual damages under existing conditions and the reduced damages that would result from the proposed nonstructural improvement.

AVERAGE ANNUAL COSTS AND BENEFITS

Table F-35 presents annual costs for the structural and nonstructural plans considered. Table F-36 indicates the average annual benefits determined for the plans considered.

TABLE F-34

TANGIER RESIDENTIAL FLOOD REDUCTION BENEFITS*
(Based on January 1983 Prices)

<u>ITEM</u>	<u>AMOUNT</u>
EXISTING BENEFIT (1983)	
Structure	\$242,441
Contents	142,386
TOTAL	<u>\$384,827</u>
BASE YEAR (1988)	
Structure	\$242,441
Contents	161,927
TOTAL	<u>\$404,368</u>
FUTURE BENEFITS - UNDISCOUNTED ¹ (2009)	
Structure	\$242,441
Contents	288,660
TOTAL	<u>\$531,101</u>
AVERAGE ANNUAL BENEFITS	
Structure	\$242,441
Contents ²	226,362
TOTAL	<u>\$468,803</u>

*Affluence calculations applied only to residential portion of benefit; commercial benefits remain constant.

¹Year in which content value will equal 75 percent of structure value.

²Undiscounted value less base year value multiplied by 0.5323 average annual equivalence factor for 7-7/8 percent, 21 years, 50-year project life.

TABLE F-35
 TANGIER ANNUAL COSTS OF STRUCTURAL AND NONSTRUCTURAL PLANS
 (Based on January 1983 Prices)

PLAN	CONSTRUCTION COST	FEDERAL SHARE	LOCAL SHARE	ANNUAL CHARGES			TOTAL
				INTEREST @ 7-7/8%	AMORTIZATION @ 0.182%	O&M ³	
				<u>STRUCTURAL PLANS</u>			
100-yr (C) ¹	\$24,891,000	\$19,913,000	\$4,978,000	\$1,960,200	\$45,300	\$497,800	\$2,503,300
St. Proj. Fid (C) ²	\$1,697,000	\$1,358,000	\$339,000	\$133,600	\$3,100	\$33,900	\$170,600
				<u>NONSTRUCTURAL PLANS</u>			
100-yr (C)	\$7,781,000	\$6,225,000	\$1,556,000	\$612,800	\$14,200	\$77,800	\$704,800
25-yr (C)	5,227,000	4,182,000	1,045,000	411,600	9,300	52,300	473,400
100-yr (V)	\$ 180,000	\$ 144,000	\$ 36,000	\$ 14,200	\$ 300	\$ 1,800	\$ 16,300

¹C = Frequency based on Corps estimate; V = Frequency based on VIMS estimate for Guard shores.
²Protection of School
³Structural O&M at 2 percent, Nonstructural O&M at 1 percent.

TABLE F-36

TANGIER AVERAGE ANNUAL BENEFITS
(Based on January 1983 prices)

<u>Plan</u>	<u>Average annual damages</u>		<u>Average annual inundation reduction benefits</u>
	<u>Existing</u>	<u>With plan of protection</u>	
<u>STRUCTURAL PLANS</u>			
100-yr (C)* St. Proj. Fld (C)	\$481,700	\$62,700	\$419,000
	\$481,700	**	**
<u>NONSTRUCTURAL PLANS</u>			
100-yr (C)	\$481,700	\$31,600	\$450,100
25-yr (C)	481,700	170,000	311,700
100-yr (V)	\$ 49,600	\$ 25,800	\$ 23,800

*C = frequency based on Corps estimate; V = frequency based on VIMS estimate.

**Not determined. School protected to provide a haven for people on island during major tidal flooding.

Table F-37 indicates the net benefits attributable to each plan as well as the benefit/cost ratios.

TABLE F-37
TANGIER ECONOMIC ANALYSIS
(Based on January 1983 Prices)

<u>PLAN</u>	<u>ANNUAL COSTS</u>	<u>AVERAGE ANNUAL NET ANNUAL</u> <u>BENEFITS</u>	<u>BENEFITS</u>	<u>BENEFIT-</u> <u>COST RATIO</u>
<u>STRUCTURAL PLANS</u>				
100-yr (C) St. Proj. Fld (C)	\$2,503,300	\$419,000	-\$2,084,300	0.17 ¹
	\$ 170,600	Not determined	--	--
<u>NONSTRUCTURAL PLANS</u>				
100-yr (C)	\$704,800	\$534,100	-\$ 170,700	0.76 ²
25-yr (C)	473,400	370,500	-102,900	0.78 ²
100-yr (V)	\$ 16,300	\$ 23,800	\$7,500	1.46 ³

¹ Affluence factor benefit not projected since b-c ratio is very small.

² Indicates effect of including affluence factor benefits.

³ Affluence factor benefit not projected since b-c ratio is greater than 1.0.

WEST POINT, VIRGINIA

WITHOUT PROJECT CONDITIONS

Natural marshlands and residential and public land uses make up approximately 93 percent of the land use in West Point. The Chesapeake Corporation is the largest industrial site within the town. The topography and flooded area in West Point are shown in Figure F-12. Elevations were established by the Corps at street intersections at and below 15th Street. Excluding the Chesapeake Corporation plant, practically all of the area (240 acres) at and below elevation 10' is located downstream from 15th Street. About 70 acres and 25 buildings are on the ground which is at or below the elevation 5' contour. Approximately 100 buildings are located on the 40 acres between the 5- and 10-foot contours. The remaining land located in this urbanized area below 15th Street is not more than a foot above elevation 10'.

The entire area below 15th Street is well developed. Of the 380 structures, 58 are commercial developments, 3 are public buildings, and the remainder are residences. The value of the contents of residences generally varies from 30 percent for class A (above average structure) to 40 percent for class C (below average structure).

FUTURE GROWTH WITHOUT PROJECT

Since the section of town below 15th Street is quite fully developed, it is questionable whether any material growth of commercial or residential property of consequence can be expected in this area. Some expansion can be expected, generally north of 15th Street, as the population and activities at West Point increase in proportion to the increase in the county. However, in accordance with the Federal Insurance Administration acts and State regulations, the first floor of future buildings will have to be raised to the elevation of the 100-year tidal flood or flood proofed to this level.

STAGE-DAMAGE RELATIONSHIP WITHOUT PROJECT

The probable future damage from tidal flooding was estimated exclusive of any damage to be sustained by the Chesapeake Corporation. A map of the town showing streets and lots was obtained. The elevation of street intersections was established in the field based on available bench marks. Then the first floor elevation of 380 structures was determined. A field inspection of each structure was conducted to establish the elevation of zero damage, type of property, class and condition of property, number of stories, basement, residential size (small, average, large), furnishings, and length and width of commercial property and its use. This information was fed into a computer which contained stage-damage data for different types and classes of property as developed by the Corps. Figure F-13 indicates the resulting stage-damage data developed for West Point.

The damage-frequency relationship was based on the stage-damage curve compiled for the area, and the stage-frequency curves as determined by the Corps and/or VIMS. The potential future loss was obtained by multiplying the damages occurring in small increments of stage by the annual expectancy of each increment of stage. The resulting incremental losses were summed to determine the average annual damage up to any tidal flood stage. Tables F-38 and F-39 indicate the results.

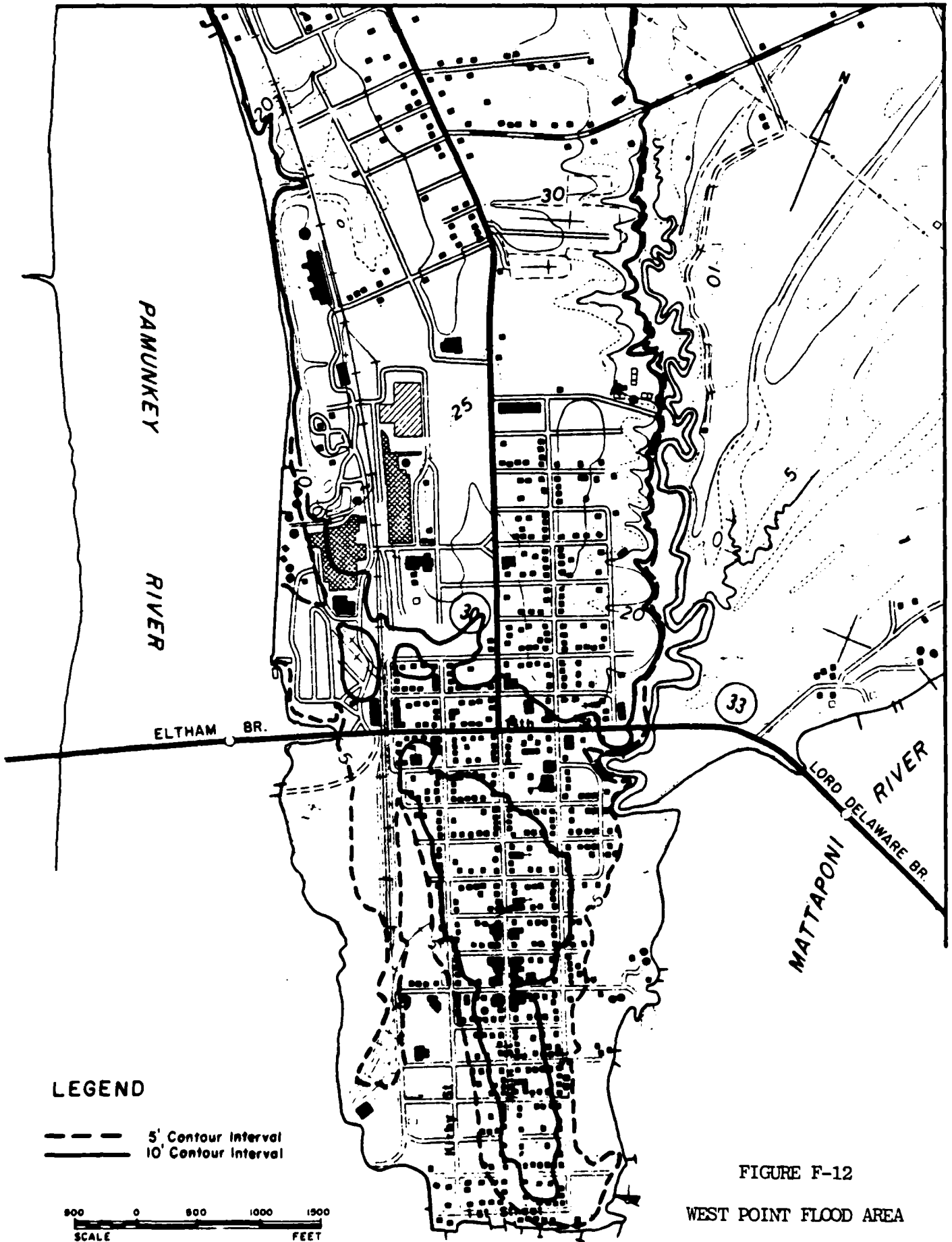

FIGURE F-12
WEST POINT FLOOD AREA

F-69

291

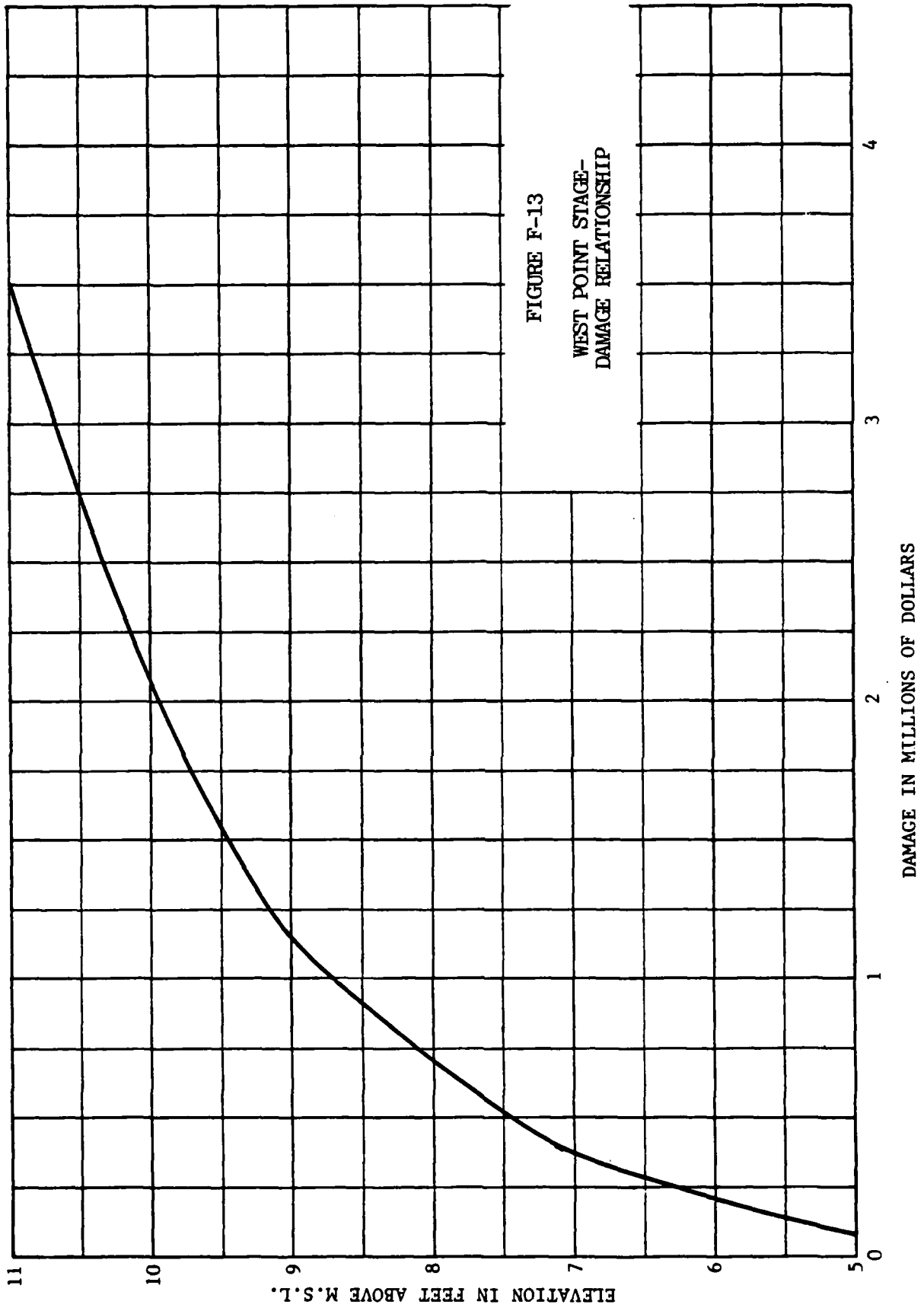

FIGURE F-13
WEST POINT STAGE-
DAMAGE RELATIONSHIP

TABLE F-38

WEST POINT AVERAGE ANNUAL FLOOD DAMAGES - CORPS FREQUENCY
(Based on January 1983 Prices)

<u>TOTAL DAMAGE \$1,000</u>	<u>FLOOD STAGE</u>	<u>PROBABILITY IN YEARS</u>	<u>INTERVAL</u>	<u>AVERAGE INTERVAL</u>	<u>ANNUAL LOSS TO STAGE NOTED</u>
3,505.80	11.00	0.00			\$ 62,477
			0.100	\$ 2,789	
2,072.30	10.00	1,000.00			59,688
			0.100	1,947	
1,821.60	9.80	500.00			57,741
			0.371	5,518	
1,149.60	9.00	175.00			52,223
			0.429	4,415	
910.80	8.50	100.00			47,808
			0.667	5,368	
699.70	8.00	60.00			42,440
			2.333	12,399	
363.10	7.00	25.00			30,040
			4.333	12,311	
205.10	6.00	12.00			17,729
			8.333	12,046	
84.00	5.00	6.00			5,683
			8.333	4,046	
13.10	4.00	4.00			1,638
			25.000	\$ 1,638	
0	3.00	2.00			\$ 0

TABLE F-39

WEST POINT AVERAGE ANNUAL FLOOD DAMAGES - VIMS FREQUENCY
(Based on January 1983 Prices)

<u>TOTAL DAMAGE \$1,000</u>	<u>FLOOD STAGE</u>	<u>PROBABILITY IN YEARS</u>	<u>INTERVAL</u>	<u>AVERAGE INTERVAL</u>	<u>ANNUAL LOSS TO STAGE NOTED</u>
1,148.40	9.00	0.00			\$ 25,591
542.50	7.60	1,000.00	0.100	\$ 845	24,745
364.30	7.00	500.00	0.100	453	24,292
205.90	6.00	120.00	0.633	1,806	22,486
198.00	5.90	100.00	0.167	337	22,150
130.70	5.40	50.00	1.000	1,644	20,506
83.20	5.00	21.00	2.762	2,954	17,552
11.90	4.00	3.00	28.571	13,586	3,967
0	3.00	1.00	66.667	\$ 3,967	\$ 0

AFFLUENCE FACTOR BENEFITS

Existing procedures permit the use of per capita income growth rates as the basis for increasing the real value of residential contents in the future and account for the affluence factor. The value of the residential contents may be projected at the per capita income growth rate up to a maximum level of 75 percent of the value of the residential structure. Since the affluence factor benefit increased the benefit-cost ratio by only 0.1 to 0.2, it was not computed for raising structures to the 100-year level since the benefit-cost ratio was only 0.5 or less. In the case of the structures raised to the Corps 25-year tidal level, the affluence factor increased the average annual benefits by \$7,100.

INUNDATION REDUCTION BENEFITS

Flood protection benefits, resulting from raising existing buildings, were determined as the difference in the average annual damage under existing conditions and the reduced damages that would result from the proposed nonstructural improvement. The inundation reduction benefits computed for the Corps and VIMS stage-frequency data are shown in Table F-40.

TABLE F-40

WEST POINT INUNDATION REDUCTION BENEFITS
(Based on January 1983 Prices)

<u>Stage Frequency data by</u>	<u>Frequency in Years</u>	<u>Number of Structures</u>	<u>Inundation Reduction Benefits</u>
Corps	100	43	\$40,200
Corps	25	17	31,200
VIMS	100	15	11,200
VIMS	25	3	\$ 7,700

AVERAGE ANNUAL COSTS AND BENEFITS

Table F-41 shows the average annual costs for the nonstructural tidal flood protection plans considered. Table F-42 indicates the benefits for the plans considered while Table F-43 indicates the net benefits attributable to each plan as well as the benefit-cost ratios.

TABLE F-41
 WEST POINT AVERAGE ANNUAL NONSTRUCTURAL COSTS
 (Based on January 1983 Prices)

STAGE FREQUENCY DATA BY	LEVEL OF PROTECTION	CONSTRUCTION COST	FEDERAL SHARE	LOCAL SHARE	ANNUAL CHARGES			TOTAL
					INTEREST @ 7-7/8%	AMORTIZATION @ 0.182%	O&M @ 1%	
Corps	100-yr.	\$1,048,000	\$838,000	\$210,000	\$82,500	\$1,900	\$10,500	\$94,900
Corps	25-yr.	465,000	372,000	93,000	36,600	800	4,700	42,100
VIMS	100-yr.	340,000	272,000	68,000	26,800	600	3,400	30,800
VIMS	25-yr.	\$90,000	\$ 72,000	\$ 18,000	\$7,100	\$200	\$ 900	\$ 8,200

TABLE F-42

WEST POINT AVERAGE ANNUAL NONSTRUCTURAL BENEFITS
(Based on January 1983 Prices)

Stage Frequency Data By	Level Of Protection	AVERAGE ANNUAL DAMAGE		AVERAGE ANNUAL BENEFITS		
		Without Project	Following Improvement	Inundation Reduction	Affluence Factor	Total
Corps	100-yr.	\$62,500	\$22,300	\$40,200	*	\$40,200
Corps	25-yr.	62,500	31,300	31,200	\$7,100	38,300
VIMS	100-yr.	25,600	14,400	11,200	*	11,200
VIMS	25-yr.	\$25,600	\$17,900	\$ 7,700	\$1,700	\$ 9,400

*Not determined.

TABLE F-43

WEST POINT NET NONSTRUCTURAL BENEFITS AND B-C RATIOS
(Based on January 1983 Prices)

Stage Frequency Data By	Level Of Protection	Annual Costs	Average Annual Benefits	Net Benefits	Benefit- Cost Ratio
Corps	100-yr.	\$94,900	\$40,200	-\$54,700	0.42
Corps	25-yr.	42,100	38,300	-3,800	0.91
VIMS	100-yr.	30,800	11,200	-19,600	0.36
VIMS	25-yr.	\$ 8,200	\$ 9,400	\$ 1,200	1.15

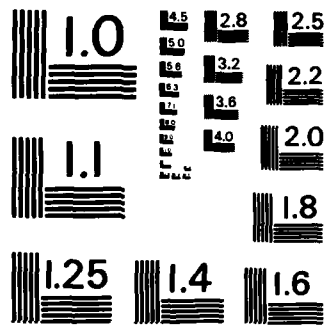

MICROCOPY RESOLUTION TEST CHART
NATIONAL BUREAU OF STANDARDS - 1963 - A

ANNEX F-1
CAMBRIDGE
STAGE-DAMAGE AND AVERAGE
ANNUAL DAMAGE COMPUTATIONS

F-1-1

STAGE DAMAGE SUMMARY TABLE (\$ x 1000)

CAMBRIDGE, DORCHESTER CO., MD

ELEVATION FLOOD STAGE	TOTAL RESIDENTIAL DAMAGE	TOTAL UTIL., TRANS, I.P.H., DAM.	TOTAL COMMERCIAL DAMAGE	TOTAL PUBLIC DAMAGE	TOTAL INDUSTRIAL DAMAGE	APPRAISAL COUNT			ELEVATION FLOOD STAGE	TOTAL COMMUNITY DAMAGE
						IND. TOT.				
						RES.	COMM.	PUB.		
4	0.0	0.3	23.2	0	1.6	0	2	0	4	25.1
5	35.4	10.2	34.9	0	30.9	37	8	0	5	111.4
6	78.4	20.8	140.4	0	54.1	60	14	0	6	293.7
7	189.7	40.1	275.8	0	74.8	105	22	0	7	580.4
8	412.4	61.6	523.0	0	103.8	137	29	0	8	1100.8
9	764.5	89.8	765.4	0	121.6	185	37	0	9	1741.3
10	1236.8	119.8	1088.1	0	136.2	218	40	0	10	2580.9
11	1865.6	159.7	1442.7	0	146.6	286	45	0	11	3614.6
12	2586.1	173.5	1769.8	0	164.8	322	47	0	12	4714.2
13	3438.3	228.1	2130.8	0	178.0	358	50	0	13	5975.2
14	4287.8	255.8	2499.3	0	189.2	358	50	0	14	7234.1
15	5154.8	280.4	2811.4	0	250.6	357	50	0	15	8477.2
16	5989.8	302.9	3213.7	0	272.4	357	50	0	16	9778.8
17	6744.6	322.0	3497.8	0	274.8	357	50	0	17	10839.2
18	7452.6	337.3	3785.8	0	275.9	357	50	0	18	11853.6

VALUES ARE BASED ON JULY, 1979 BCI. (WITHOUT PROJECT CONDITIONS)
 SURVEY PERFORMED DURING 1979

CALCULATION OF AVERAGE ANNUAL DAMAGES PLANS CA-1 & CA-4		BASIN CHESAPEAKE BAY	REACH CAMBRIDGE, MD	LT. RT. BANK <input type="checkbox"/> <input type="checkbox"/>
TYPE OF DAMAGE TIDAL FLOODING		TERRITORY CHOPTANK RIVER	UPSTREAM LIMIT OF REACH -	
PRICE LEVEL OF JUL '79		STREAM -	DOWNSTREAM LIMIT OF REACH -	
CONDITIONS OF	REFERENCE GAGE OR POINT CAMBRIDGE (VIMS)	DRAINAGE AREA SQ. MI.	COMPLETED BY GMB	DATE 4/15/80
			CHECKED BY SKC	DATE 4/80

FLOOD (1)	DISCHARGE (cfs) (2)	STAGE (Ft.)		FREQUENCY		DAMAGES (Dollars) X1000		AVE. ANNUAL DAMAGES X1000	
		RF (3)	MSL (4)	% (5)	Interval (6)	At Stage (7)	Average (8)	Interval (9)	Summation (10)
			3.0	41		0.0			0.0
			4.0	8.0	33	5.6	2.80	0.924	0.924
			5.0	2.4	56	86.8	46.20	2.587	3.511
			6.0	0.82	158	255.5	171.15	2.704	6.215
			7.0	0.21	0.51	527.8	391.65	1.997	8.212
			8.0	0.15	0.16	1004.4	766.10	1.226	9.438
			9.0	0.05	0.094	1609.6	1307.00	1.229	10.667
			10.0	0.045	0.011	2397.3	2003.45	0.220	10.887
			11.0	0.032	0.013	3325.7	2861.50	0.372	11.259
			12.0	0.022	0.006	4251.9	3788.80	0.227	11.486
			13.0	0.021	0.005	5214.4	4733.15	0.237	11.723
			14.0	0.019	0.002	6128.7	5671.55	0.113	11.836
			15.0	0.017	0.002	7021.4	6575.05	0.132	11.968
			16.0	0.015	0.002	7983.4	7502.40	0.150	12.118
			17.0	0.012	0.002	8782.8	8383.10	0.168	12.286
			18.0	0.012	0.001	9601.9	9192.35	0.092	12.378

REMARKS: DAMAGES PREVENTED

CALCULATION OF AVERAGE ANNUAL DAMAGES		SACIA		REACH		LT. RT. BANK			
PLANS CA-2 & CA-5		CHESAPEAKE BAY		CAMBRIDGE, MD		<input type="checkbox"/> <input type="checkbox"/>			
TYPE OF DAMAGE		DISTRICT		UPSTREAM LIMIT OF REACH					
TIDAL FLOODING		CHOPTANK RIVER		-					
PRICE LEVEL OF		REFERENCE GAGE OR POINT		DRAINAGE AREA		COMPUTED BY			
JUL '79		CAMBRIDGE, MD		SO. MI.		DATE			
CONDITIONS OF						CHECKED BY			
						DATE			
						4/15/80			
						SKC			
						4/80			
FLOOD (1)	DISCHARGE (cfs) (2)	STAGE (Ft.)		FREQUENCY		DAMAGES (Dollars) X1000		AVE. ANNUAL DAMAGES X1000	
		RF (3)	MSL (4)	% (5)	Interval (6)	At Stage (7)	Average (8)	Interval (9)	Summation (10)
			3.0	41	-	0.0	-	-	0.0
			4.0	8.0	33	5.6	2.80	0.924	0.924
			5.0	2.4	5.6	60.9	33.25	1.862	2.786
			6.0	0.82	1.58	186.9	123.90	1.958	4.744
			7.0	0.21	0.51	353.8	270.35	1.379	6.123
			8.0	0.15	0.16	634.6	494.20	0.791	6.914
			9.0	0.056	0.094	928.1	781.35	0.734	7.648
			10.0	0.045	0.011	1325.9	1127.00	0.124	7.772
			11.0	0.022	0.013	1782.4	1554.15	0.202	7.974
			12.0	0.022	0.006	2218.9	2000.65	0.120	8.094
			13.0	0.021	0.005	2710.1	2464.50	0.123	8.217
			14.0	0.010	0.002	3214.9	2962.50	0.059	8.276
			15.0	0.017	0.002	3724.8	3469.85	0.069	8.345
			16.0	0.013	0.002	4303.3	4014.05	0.080	8.425
			17.0	0.013	0.002	4585.7	4444.50	0.089	8.514
			18.0	0.012	0.001	5103.6	4844.65	0.048	8.562

REMARKS: DAMAGES PREVENTED

CALCULATION OF AVERAGE ANNUAL DAMAGES		BASIN CHESAPEAKE BAY		REACH CAMBRIDGE, MD		LT. RT. RANK <input type="checkbox"/> <input type="checkbox"/>	
PLAN CA-7		TRIBUTARY CHOPTANK RIVER		UPSTREAM LIMIT OF REACH -			
TYPE OF DAMAGE TIDAL FLOODING		STREAM -		DOWNSTREAM LIMIT OF REACH -			
PRICE LEVEL OF JUL '79	CONDITIONS OF	REFERENCE GAGE OR POINT CAMBRIDGE VVPS	DRAINAGE AREA SQ. MI.	COMPUTED BY GMB	DATE 6/80	CHECKED BY ESM	DATE 7/80

FLOOD (1)	DISCHARGE (cfs) (2)	STAGE (Ft.)		FREQUENCY		DAMAGES (Dollars) X 1000		AVE. ANNUAL DAMAGES X 1000	
		RF (3)	MSL (4)	% (5)	Interval (6)	At Stage (7)	Average (8)	Interval (9)	Summation (10)
			3.0	41	—	0.0	—	—	0.0
			4.0	8.0	33	0.3	0.15	0.050	0.050
			5.0	2.4	5.6	16.9	8.60	0.482	0.531
			6.0	0.82	1.58	253.2	135.05	2.134	2.665
			7.0	0.21	0.51	540.1	396.65	2.023	4.688
			8.0	0.15	0.16	1072.2	606.15	1.290	5.978
			9.0	0.05%	0.094	1711.9	1392.05	1.309	7.286
			10.0	0.045	0.011	2549.8	2130.85	0.234	7.521
			11.0	0.032	0.013	3588.0	3068.90	0.399	7.920
			12.0	0.024	0.006	4692.6	4140.30	0.248	8.168
			13.0	0.021	0.005	5955.1	5323.85	0.266	8.434
			14.0	0.019	0.002	7214.7	6584.90	0.132	8.566
			15.0	0.017	0.002	8478.2	7846.45	0.157	8.723
			16.0	0.015	0.002	9759.9	9119.05	0.182	8.905
			17.0	0.013	0.002	10820.3	10290.10	0.206	9.111
			18.0	0.012	0.001	11834.4	11327.35	0.113	9.224

REMARKS: DAMAGES REMAINING

ANNEX F-II

CRISFIELD

STAGE-DAMAGE AND AVERAGE
ANNUAL DAMAGE COMPUTATIONS

F-II-1

STAGE DAMAGE SUMMARY TABLE (\$ X 1000)
 CRISFIELD, SOMERSET COUNTY, MD.

ELEVATION FLOOD STAGE	TOTAL RESIDENTIAL DAMAGE	TOTAL UTIL, TRANS, P.H. DAM.	TOTAL COMMERCIAL DAMAGE	TOTAL PUBLIC DAMAGE	TOTAL INDUSTRIAL DAMAGE	APPRAISAL COUNT			ELEVATION FLOOD STAGE	TOTAL COMMUNITY DAMAGE
						RES.	COMM	PUB.		
2	0.0	0.1	0.2	0.0	0.0	0	2	0	0	0.3
3	27	32	65	0.0	0.0	10	3	0	0	12.4
4	38.6	24.2	81.1	52.1	0.0	57	19	3	0	198.0
5	314.1	195.4	839.1	218.9	2.1	364	162	13	3	1569.6
6	1116.39	424.3	1828.7	512.0	16.5	1133	193	18	4	3945.4
7	2861.0	666.6	3107.7	800.2	101.6	1526	203	24	4	7537.1
8	5386.9	865.5	4806.6	1180.4	359.6	1668	207	27	4	12599.0
9	8454.3	1035.1	6579.6	1495.7	706.3	1679	208	29	4	18271.0
10	11531.8	1176.4	7949.2	1939.6	1107.7	1679	208	30	4	23764.7
11	14250.3	1285.9	9028.8	2230.5	1700.1	1679	208	30	4	28495.6
12	16423.6	1358.5	9696.5	2510.1	1941.6	1679	208	31	4	31930.3
13	17974.5	1406.2	10109.3	2731.1	2063.3	1679	208	31	4	34364.4
14	19225.7	1451.2	10354.8	2936.5	2193.5	1679	208	31	4	36161.7
15	20602.6	1512.7	11055.3	3077.6	2239.1	1679	208	31	4	38487.3
16	22433.5	1593.4	11467.5	3161.1	2273.1	1679	208	31	4	40928.6

\$ VALUES ARE BASED ON JULY, 1979 DCI. (WITHOUT PROJECT CONDITIONS)
 SURVEY PERFORMED DURING 1979

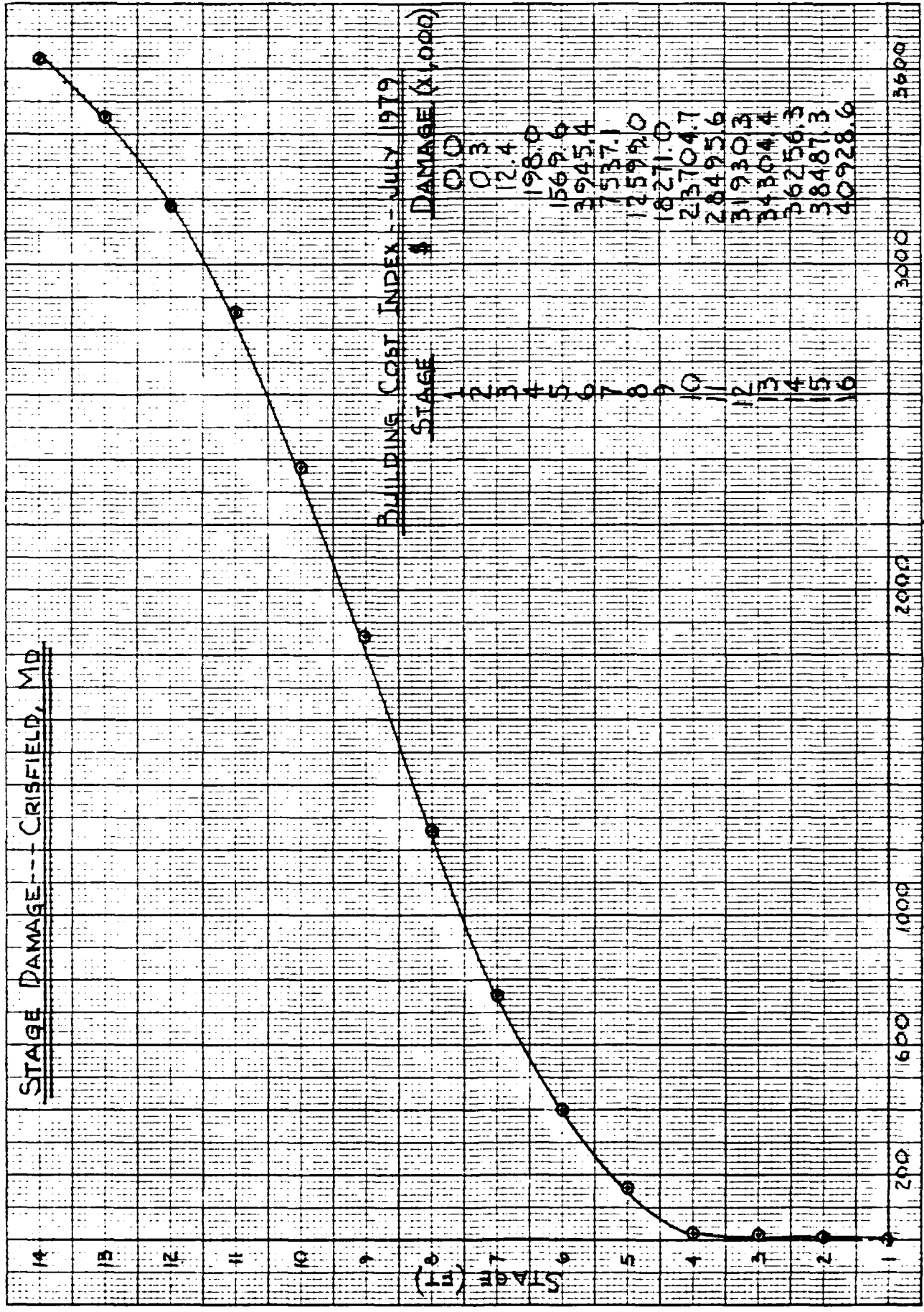

STAGE DAMAGE --- CRISFIELD, MD

BUILDING COST INDEX -- JULY 1979

STAGE

DAMAGE (x,000)

3600

3000

2000

1000

200

DAMAGE \$ (x10,000)

CALCULATION OF AVERAGE ANNUAL DAMAGES CHBTFCF		BASIN CHESAPEAKE BAY	REACH CRISFIELD, MD	LT. RT. <input type="checkbox"/> <input type="checkbox"/>
TYPE OF DAMAGE TIDAL FLOODING		TRIBUTARY TANGIER SOUND	UPSTREAM LIMIT OF REACH N/A	
PRICE LEVEL OF JUL 1979		CONCITIONS OF BASE	REFERENCE GAGE OR POINT CRISFIELD (VIMS)	DRAINAGE AREA. SQ. MI.
		STREAM N/A	DOWNSTREAM LIMIT OF REACH N/A	
			COMPUTED BY MB	DATE 5/80
			CHECKED BY EEM	DATE 6/80

FLOOD (1)	DISCHARGE (cfs) (2)	STAGE (Ft.)		FREQUENCY		DAMAGES (Dollars) X1000		AVE. ANNUAL DAMAGES X1000	
		RF (3)	MSL (4)	% (5)	Interva. (6)	At Stage (7)	Average (8)	Interval (9)	Summation (10)
			1	100	0.0	0.0	0.0	0.0	0.0
			2	93	7.0	0.3	0.150	0.011	0.011
			3	42	51.0	12.4	6.350	3.239	3.249
			4	8	34.0	198.0	105.200	35.768	39.017
			5	1.2	6.80	1569.6	883.800	60.098	99.115
			6	0.25	0.950	3945.4	2757.500	26.196	125.310
			7	0.07	0.180	7537.1	5741.250	10.334	135.646
			8	0.025	0.045	12599.0	10068.050	4.531	140.177
			9	0.01	0.015	18271.0	15435.000	2.315	142.492
			10	0.01	0.000	23704.7	20987.850	0.000	
			11	0.01		28495.6	26100.150		
			12	0.01		31390.3	29942.950		
			13	0.01		34304.4	32847.350		
			14	0.01		36257.3	35280.850		
			15	0.01		38487.3	37372.300		
			16	0.01		40928.6	39707.950		

REMARKS:

CALCULATION OF AVERAGE ANNUAL DAMAGES		BASIN CHESAPEAKE BAY	REACH CRISFIELD	LT. <input type="checkbox"/>	PT. <input type="checkbox"/>
PLANS CR-3 & CR-4		TRIBUTARY TAUGHER SOUND	UPSTREAM LIMIT OF REACH -		
TYPE OF DAMAGE TIDAL FLOODING		STREAM -	DOWNSTREAM LIMIT OF REACH -		
PRICE LEVEL OF JUL '79	CONDITIONS OF	REFERENCE GAGE OR POINT CRISFIELD (VIMS)	DRAINAGE AREA SQ. MI.	COMPUTED BY JMB	DATE 4/15/80
				CHECKED BY SKC	DATE 4/80

FLOOD (1)	DISCHARGE (cfs) (2)	STAGE (Ft.)		FREQUENCY		DAMAGES (Dollars) X1000		AVE. ANNUAL DAMAGES X1000	
		RF (3)	MSL (4)	% (5)	Interval (6)	At Stage (7)	Average (8)	Interval (9)	Summation (10)
			1.0	99	-	0.0	-	-	0.0
			2.0	93	6.0	0.3	0.15	0.009	0.009
			3.0	42	51	7.5	3.90	1.989	1.998
			4.0	8	34	125.4	66.45	22.593	24.591
			5.0	1.2	6.8	1027.6	576.50	39.202	63.793
			6.0	0.25	0.95	2986.7	2007.15	19.068	82.861
			7.0	0.07	0.18	5766.8	4376.75	7.878	90.739
			8.0	0.025	0.045	9734.7	7750.75	3.488	94.227
			9.0	0.010	0.015	14,337.9	12036.30	1.805	96.032
			10.0	0.010	0.0	18,770.8	16554.35	0.0	96.032
			11.0	0.010	0.0	22,799.8	20785.30	0.0	96.032
			12.0	0.010	0.0	25,669.4	24234.60	0.0	96.032
			13.0	0.010	0.0	27,671.1	26670.25	0.0	96.032
			14.0	0.010	0.0	29,227.2	28449.15	0.0	96.032
			15.0	0.010	0.0	30,889.6	30058.40	0.0	96.032
			16.0	0.010	0.0	32,877.6	31883.60	0.0	96.032

REMARKS: DAMAGES PREVENTED CR-3 & CR-4

CALCULATION OF AVERAGE ANNUAL DAMAGES PLAN CR-5		BASIN CHESAPEAKE BAY	REACH CRISFIELD	LT. RT. <input type="checkbox"/> <input type="checkbox"/>
TYPE OF DAMAGE DA FLOODING		TRIBUTARY LAGER CREEK	UPSTREAM LIMIT OF REACH -	
PRICE LEVEL OF -		STREAM -	DOWNSTREAM LIMIT OF REACH -	
CONDITIONS OF -		REFERENCE GAGE OR POINT CRISFIELD (VIMS)	DRAINAGE AREA SQ. MI.	COMPUTED BY JHE
			DATE 6/80	CHECKED BY BJM
			DATE 7/80	

FLOOD	DISCHARGE (cfs) (2)	STAGE (Ft.)		FREQUENCY		DAMAGES (Dollars) x1000		AVG. ANNUAL DAMAGES x1000	
		RF (3)	MSL (4)	% (5)	Interva. (6)	At Stage (7)	Average (8)	Interval (9)	Summation (10)
			1.0	99	6.0	0.0			0.0
			2.0	93	51	0.3	0.15	0.009	0.009
			3.0	42	34	10.1	5.20	2.652	2.661
			4.0	8	6.8	93.3	51.70	17.578	20.239
			5.0	1.2	0.95	1536.3	814.80	55.406	75.645
			6.0	0.75	0.18	3892.1	2714.20	25.785	101.430
			7.0	0.07	0.045	7468.7	5680.40	10.225	111.655
			8.0	0.025	0.015	12507.5	9988.10	4.495	116.150
			9.0	0.010	0.0	18178.2	15342.85	2.301	118.451
			10.0	0.005	0.0	23610.4	20894.30	0.0	118.451
			11.0	0.003	0.0	28398.5	26004.45	0.0	118.451
			12.0	0.002	0.0	31827.9	30113.20	0.0	118.451
			13.0	0.001	0.0	34194.6	33011.25	0.0	118.451
			14.0	0.001	0.0	36044.1	35119.35	0.0	118.451
			15.0	0.001	0.0	38366.2	37205.15	0.0	118.451
			16.0	0.001	0.0	40804.3	39585.25	0.0	118.451

REMARKS: DAMAGES REMAINING CR-5

CALCULATION OF AVERAGE ANNUAL DAMAGES		BASIN CHESAPEAKE BAY	REACH CRISFIELD	LT. RT. BANK <input type="checkbox"/> <input type="checkbox"/>
PLAN CR-6		TRIBUTARY RIDGE ROAD	UPSTREAM LIMIT OF REACH -	
TYPE OF DAMAGE TIDAL FLOODING		STREAM -	DOWNSTREAM LIMIT OF REACH -	
WATER LEVEL OF 0.0	CONDITIONS OF -	REFERENCE GAGE OR POINT CRISFIELD (VIMS)	DRAINAGE AREA 50. MI.	COMPUTED BY SIE
				DATE 6/80
				CHECKED BY CJM
				DATE 7/80

FLOOD 1	DISCHARGE (cfs) (2)	STAGE (Ft.)		FREQUENCY		DAMAGES (Dollars) X 1000		AVG. ANNUAL DAMAGES X 1000	
		RF (3)	MSL (4)	% (5)	Interva. (6)	At Stage (7)	Average (8)	Interval (9)	Summation (10)
			1.0	99	6.0	0.0	0.0	0.0	0.0
			2.0	93	51	0.0	0.65	0.332	0.0
			3.0	42	34	1.3	11.40	3.876	0.332
			4.0	8	6.8	21.5	258.45	17.575	4.208
			5.0	1.2	0.95	495.4	1925.35	18.291	21.782
			6.0	0.25	0.18	3355.3	5045.00	9.081	40.073
			7.0	0.07	0.045	6734.7	9118.15	4.103	49.154
			8.0	0.025	0.015	11501.6	14281.85	2.142	53.257
			9.0	0.010	0.0	17062.1	19751.90	0.0	55.399
			10.0	0.005	0.0	22441.7	24830.40	0.0	55.399
			11.0	0.003	0.0	27219.1	28925.75	0.0	55.399
			12.0	0.001	0.0	30632.4	31794.60	0.0	55.399
			13.0	0.001	0.0	32956.8	33862.20	0.0	55.399
			14.0	0.001	0.0	34767.6	35787.60	0.0	55.399
			15.0	0.001	0.0	36807.6	38015.30	0.0	55.399
			16.0	0.001		39223.0			55.399

REMARKS: DAMAGES REMAINING CR-6

ANNEX F-III
POCOMOKE CITY
STAGE-DAMAGE AND AVERAGE
ANNUAL DAMAGE COMPUTATIONS

F-III-1

STAGE DAMAGE SUMMARY TABLE (\$ X 1000)
 ROCOMOKE CITY, WORCESTER COUNTY, MD

ELEVATION FLOOD STAGE	TOTAL RESIDENTIAL DAMAGE	TOTAL UTIL, TRANS, P.H. DAM.	TOTAL COMMERCIAL DAMAGE	TOTAL PUBLIC DAMAGE	TOTAL INDUSTRIAL DAMAGE	APPRAISAL COUNT			ELEVATION FLOOD STAGE	TOTAL COMMUNITY DAMAGE	
						RES.	COMM	PUB.			IND.
3	210	0.6	3.8	0.0	0.0	11	11	0	0	2	6.4
4	38	112	9.6	0.0	0.0	2	1	0	0	3	14.6
5	2110	42	324	0.0	5.3	16	4	0	1	21	63.9
6	90.4	137	69.9	0.0	42.9	43	8	0	1	52	216.9
7	214.8	314	148.3	0.0	257.6	73	14	0	1	108	652.1
8	391.4	57.3	276.1	5.6	529.8	145	30	1	2	178	1260.2
9	656.8	93.2	582.1	13.0	796.2	207	46	1	2	256	2141.3
10	992.7	136.8	1107.2	33.9	1335.5	253	72	3	2	380	3571.3
11	1458.0	204.0	1796.5	117.3	1570.1	372	91	6	2	471	5145.9
12	1993.3	289.2	2798.1	281.4	2695.8	507	100	13	2	622	7057.8
13	2689.2	320.5	3827.5	366.2	3949.7	558	102	16	3	677	9093.1
14	3471.0	427.0	4949.2	559.1	4917.0	594	103	18	3	718	11343.3
15	4385.0	474.2	5781.1	717.6	5938.6	597	103	18	3	721	13296.5
16	5226.9	516.0	6539.8	888.2	6975.2	597	103	18	3	721	15146.1
17	6041.3	551.3	7041.1	1089.1	8155.0	597	103	18	3	721	17178.4
18	6880.2	580.9	7388.7	1252.1	8922.8	597	103	18	3	721	18514.7

\$ VALUES ARE BASED ON JULY, 1979 BCI. (WITHOUT PROJECT CONDITIONS)
 SURVEY PERFORMED DURING 1979

STAGE DAMAGE -- POCOMOKE CITY

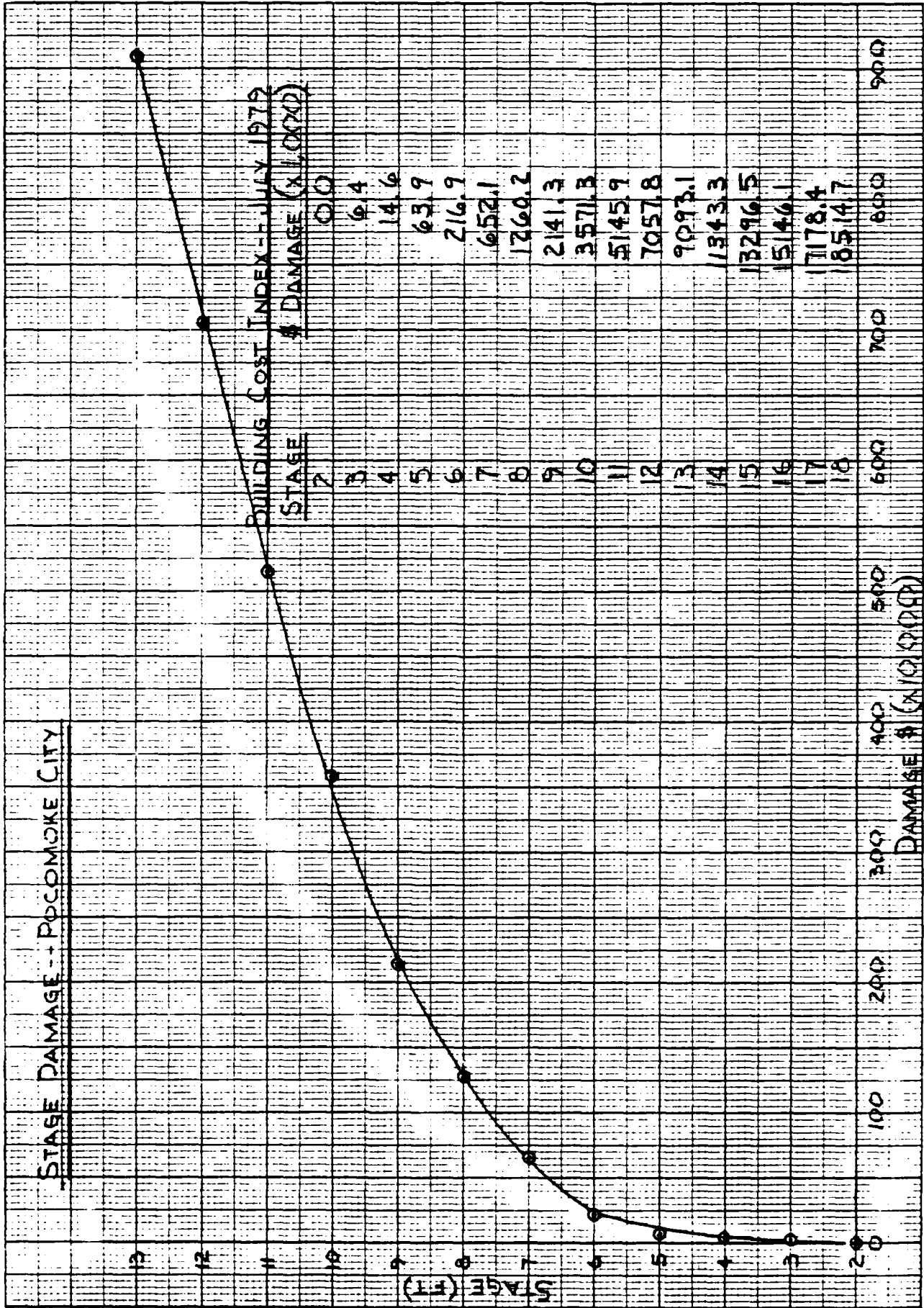

CALCULATION OF AVERAGE ANNUAL DAMAGES PLANS PC-1 & PC-2		HASIN CHESAPEAKE BAY	REACH POCONOKE CITY	LT. RT. BANK
TYPE OF DAMAGE TIDAL FLOODING		TRIBUTARY POCONOKE RIVER	UPSTREAM LIMIT OF REACH	
PRICE LEVEL OF CONDITIONS OF JUL '79		REFERENCE GAGE OR POINT GUARDSH (NHC)	DRAINAGE AREA SQ. MI. 50 MI.	COMPUTED BY VTE
			DATE 4/80	CHECKED BY SKC
			DATE 4/80	

FLOOD (1)	DISCHARGE (cfs) (2)	STAGE (Ft.)		FREQUENCY		DAMAGES (Dollars) X 1000		AVG. ANNUAL DAMAGES X 1000	
		RF (3)	RF (4)	% (5)	Interval (6)	At Stage (7)	Average (8)	Interval (9)	Summation (10)
			2.0	98	56	0.0	3.15	1.764	0.0
			3.0	42	30	6.3	10.45	3.135	1.764
			4.0	12	78	14.6	34.20	2.663	4.899
			5.0	4.2	2.8	53.8	106.55	2.983	7.567
			6.0	1.4	0.95	159.3	338.40	3.215	10.550
			7.0	0.45	0.28	517.5	775.65	2.172	13.765
			8.0	0.17	0.085	1033.8	1419.75	1.207	15.937
			9.0	0.075	0.035	1805.7	2457.75	0.860	17.144
			10.0	0.050	0.018	3109.8	3816.15	0.687	18.004
			11.0	0.032	0.009	4522.5	5384.05	0.465	18.691
			12.0	0.023	0.005	6246.6	7150.55	0.358	19.176
			13.0	0.019	0.003	8055.5	9068.20	0.272	19.534
			14.0	0.013	0.001	10,080.9	10935.00	0.109	19.806
			15.0	0.014	0.001	11,789.1	12601.25	0.126	19.915
			16.0	0.013	0.001	13,413.4	14339.45	0.142	20.041
			17.0	0.012	0.001	15,265.5	15850.65	0.159	20.154
			18.0	0.011		16,435.8			20.242

REMARKS: DAMAGES PREVENTED FOR PC-1 & PC-2

CALCULATION OF AVERAGE ANNUAL DAMAGES PLAN PC-3		BASIN CHESAPEAKE BAY	REACH POCOMOKE CITY	LT. RT. BANK <input type="checkbox"/> <input type="checkbox"/>
TYPE OF DAMAGE TIDAL FLOODING		TRIBUTARY POCOMOKE RIVER	UPSTREAM LIMIT OF REACH -	
PRICE LEVEL OF JUL '79		CONDITIONS OF	REFERENCE GAGE OR POINT GUARD SH. (VIMS)	DRAINAGE AREA SO. MI.
			COMPUTED BY QMB	DATE 5/80
			CHECKED BY ESM	DATE 6/80
			DOWNSTREAM LIMIT OF REACH -	

FLOOD (1)	DISCHARGE (cfs) (2)	STAGE (Ft.)		FREQUENCY		DAMAGES (Dollars) X 1000		AVE. ANNUAL DAMAGES X 1000	
		RF (3)	MSL (4)	% (5)	Interval (6)	At Stage (7)	Average (8)	Interval (9)	Summation (10)
			2.0	98	56	0.0	0.0	0.0	0.0
			3.0	42	30	0.0	0.15	0.045	0.0
			4.0	12	7.8	0.3	8.85	0.690	0.045
			5.0	4.2	2.8	17.4	90.05	2.521	0.735
			6.0	1.4	0.95	162.7	369.35	3.509	3.257
			7.0	0.45	0.28	576.0	872.45	2.443	6.766
			8.0	0.17	0.085	1168.9	1605.45	1.365	9.208
			9.0	0.085	0.035	2042.0	2755.70	0.964	10.573
			10.0	0.050	0.018	3469.4	4257.20	0.766	11.538
			11.0	0.032	0.009	5045.0	5999.95	0.540	12.304
			12.0	0.023	0.005	6954.9	7971.80	0.399	12.844
			13.0	0.018	0.003	8988.7	10120.05	0.304	13.242
			14.0	0.015	0.001	11251.4	12236.40	0.122	13.546
			15.0	0.014	0.001	13221.4	14160.70	0.142	13.668
			16.0	0.013	0.001	15100.0	16137.65	0.161	13.810
			17.0	0.012	0.001	17175.3	17858.25	0.179	13.971
			18.0	0.011		18541.2			14.150

REMARKS: **DAMAGES REMAINING--PC-3**

501

CALCULATION OF AVERAGE ANNUAL DAMAGES PLAN PC-4		BASIN CHESAPEAKE BAY	REACH POCOMOKE CITY	LT. RT. BANK <input type="checkbox"/>
TYPE OF DAMAGE TIDAL FLOODING		TRIBUTARY POCOMOKE RIVER	UPSTREAM LIMIT OF REACH -	
PRICE LEVEL OF JUL '79		CONDITIONS OF -	REFERENCE GAGE OR POINT GUARD SH. (VIMS)	DRAINAGE AREA SQ. MI. -
-		DOWNSTREAM LIMIT OF REACH -		COMPUTED BY JMB
-		-		DATE 5/80
-		-		CHECKED BY ESM
-		-		DATE 6/80

FLOOD (1)	DISCHARGE (cfs) (2)	STAGE (Ft.)		FREQUENCY		DAMAGES (Dollars) X 1000		AVE. ANNUAL DAMAGES X 1000	
		RF (3)	PERCENT (4)	% (5)	Interval (6)	At Stage (7)	Average (8)	Interval (9)	Summation (10)
			2.0	98		0.0			0.0
			3.0	42	56	0.0	0.0	0.0	0.0
			4.0	12	30	0.3	0.15	0.045	0.045
			5.0	4.2	7.8	3.9	2.10	0.164	0.209
			6.0	1.4	2.8	69.9	36.9	1.033	1.242
			7.0	0.45	0.95	544.1	307.00	2.917	4.159
			8.0	0.17	0.28	1130.9	837.50	2.345	6.504
			9.0	0.095	0.085	2003.5	1567.20	1.332	7.836
			10.0	0.050	0.035	3434.4	2718.95	0.952	8.787
			11.0	0.032	0.018	5012.5	4223.45	0.760	9.547
			12.0	0.023	0.009	6921.4	5966.95	0.537	10.084
			13.0	0.019	0.005	8951.6	7936.50	0.397	10.481
			14.0	0.015	0.003	11204.1	10077.85	0.302	10.784
			15.0	0.014	0.001	13163.9	12184.00	0.122	10.905
			16.0	0.013	0.001	15034.2	14099.05	0.141	11.046
			17.0	0.012	0.001	17105.0	16069.60	0.161	11.207
			18.0	0.011	0.001	18468.7	17786.85	0.178	11.385

REMARKS:
DAMAGES REMAINING PC-4

ANNEX F-IV
ROCK HALL
STAGE-DAMAGE AND AVERAGE
ANNUAL DAMAGE COMPUTATIONS

F-IV-1

STAGE DAMAGE SUMMARY TABLE (\$ 1,000)

ROCK HALL, MD.

1 2 3 4 5 6 7 8 9 10 11

ELEVATION/ FLOOR STAGE	TOTAL RESIDENTIAL DAMAGE		TOTAL UTIL., TRANS., P.H. DAM.		TOTAL COMMERCIAL DAMAGE		TOTAL PUBLIC DAMAGE		TOTAL INDUSTRIAL DAMAGE		APPRAISAL COUNT			ELEVATION FLOOD STAGE		TOTAL COMMUNITY DAMAGE
	RESIDENTIAL DAMAGE	TOTAL	UTIL., TRANS., P.H. DAM.	TOTAL	COMMERCIAL DAMAGE	TOTAL	PUBLIC DAMAGE	TOTAL	INDUSTRIAL DAMAGE	RES.	COMM. PUB.	IND.	TOT.	FLOOD STAGE		
3	0.3	0.3	0.0	0.0	0.0	0.0	0.0	0.0	0.0	0.0	0	0	0	4	3	1.0
4	11.4	11.4	7.4	21.3	0	0	0	0	1.7	0	29	5	0	35	4	46.8
5	55.2	55.2	26.3	66.3	0	0	0	0	2.4	0	81	16	0	102	5	150.2
6	183.0	183.0	51.3	194.5	0	0	0	0	12.1	0	143	17	0	166	6	390.9
7	424.2	424.2	81.4	245.5	0	0	0	0	23.5	0	202	21	0	229	7	774.6
8	792.5	792.5	119.4	375.5	0	0	0	0	32.5	0	276	22	0	305	8	1319.9
9	1130.0	1130.0	154.7	545.5	0	0	0	0	77.1	0	317	22	0	346	9	2094.3
10	1937.4	1937.4	185.2	683.9	0	0	0	0	100.8	0	344	23	0	374	10	2969.3
11	2609.5	2609.5	213.3	813.0	0	0	0	0	136.4	0	367	24	0	398	11	3772.2
12	3327.8	3327.8	244.2	909.5	0.15	0.15	0.15	0.15	176.2	0.15	423	24	1	455	12	4639.9
13	3961.0	3961.0	272.1	1000.9	68.2	68.2	68.2	68.2	184.7	68.2	442	27	3	479	13	5486.9
14	4575.5	4575.5	303.4	1094.0	79.6	79.6	79.6	79.6	195.9	79.6	481	31	4	525	14	6268.4
15	5221.0	5221.0	340.2	1182.2	113.6	113.6	113.6	113.6	199.3	113.6	527	33	6	574	15	7056.3
16	5901.2	5901.2	381.3	1303.4	138.9	138.9	138.9	138.9	224.3	138.9	575	35	7	625	16	7949.1
17	6671.4	6671.4	419.6	1450.8	185.1	185.1	185.1	185.1	238.0	185.1	600	38	8	654	17	8964.9
18	7535.4	7535.4	457.2	1590.8	246.2	246.2	246.2	246.2	243.1	246.2	613	44	8	673	18	10074.1

VALUES ARE BASED ON JULY, 1979 BCI. (WITHOUT PROJECT CONDITION)
SURVEY PERFORMED DURING 1979

CALCULATION OF AVERAGE ANNUAL DAMAGES: PLAN RH-10		BASIN CHESAPEAKE BAY			REACH ROCK HALL MD			LT. RT. <input type="checkbox"/> <input type="checkbox"/>	
		TRIBUTARY CHESTER RIVER			UPSTREAM LIMIT OF REACH —				
TYPE OF DAMAGE TIDAL FLOODING		STREAM —			DOWNSTREAM LIMIT OF REACH —				
PRICE LEVEL OF JUL 79	CONDITIONS OF	REFERENCE GAGE OR POINT TOLCHESTER (VIMS)			DRAINAGE AREA SQ. MI.	COMPUTED BY JMB	DATE 6/80	CHECKED BY ESM	DATE 6/80
FLOOD (1)	DISCHARGE (cfs) (2)	STAGE (Ft.)		FREQUENCY		DAMAGES (Dollars) x 1000		AVE. ANNUAL DAMAGES x 1000	
		RF (3)	MSL (4)	% (5)	Interval (6)	At Stage (7)	Average (8)	Interval (9)	Summation (10)
			2.0	50	—	0.0	—	—	0.0
			3.0	24	26	0.0	0.0	0.0	0.0
			4.0	13	11	0.5	0.25	0.028	0.028
			5.0	6.7	6.3	2.1	1.30	0.082	0.109
			6.0	3.9	2.8	20.6	11.35	0.318	0.427
			7.0	2.2	1.7	63.8	42.20	0.717	1.145
			8.0	1.3	0.9	224.8	144.30	1.299	2.443
			9.0	0.7	0.6	1117.2	671.00	4.026	6.469
			10.0	0.4	0.3	1753.8	1435.50	4.307	10.776
			11.0	0.28	0.12	2491.3	2122.55	2.547	13.323
			12.0	0.19	0.09	3298.4	2894.85	2.605	15.928
			13.0	0.15	0.04	4113.7	3706.05	1.482	17.411
			14.0	0.13	0.02	4834.8	4474.25	0.895	18.305
			15.0	0.1	0.03	5504.9	5169.85	1.551	19.856
			16.0	0.08	0.02	6213.5	5859.20	1.172	21.028
			17.0	0.05	0.03	7078.4	6645.95	1.994	23.022
			18.0	0.02	0.03	8044.2	7561.30	2.268	25.290
REMARKS: DAMAGES REMAINING RH-10									

ANNEX F-V
SNOW HILL
STAGE-DAMAGE AND AVERAGE
ANNUAL DAMAGE COMPUTATIONS

F-V-1

STAGE DAMAGE SUMMARY TABLE (\$ X 1000)
 SNOW HILL, WORCESTER COUNTY, MD

ELEVATION FLOOR STAGE	TOTAL RESIDENTIAL DAMAGE	TOTAL UTIL, TRANS, PH. DAM.	TOTAL COMMERCIAL DAMAGE	TOTAL PUBLIC DAMAGE	TOTAL INDUSTRIAL DAMAGE	APPRAISAL COUNT			ELEVATION FLOOD STAGE	TOTAL COMMUNITY DAMAGE	
						RES.	COMM	PUB.			IND.
4	0.1	0.6	0.9	0.0	0.0	1	2	0	0	3	1.6
5	1.5	2.4	3.3	0.0	47.9	4	8	0	1	13	55.1
6	6.0	8.3	57.5	0.0	69.0	13	14	0	1	28	140.8
7	22.4	21.6	148.2	0.0	112.7	37	20	0	3	62	304.9
8	71.2	34.9	375.5	9.4	186.9	62	22	1	3	88	677.9
9	152.8	50.2	570.5	244.9	210.9	77	22	2	3	106	1249.3
10	260.7	44.4	809.6	486.9	225.4	71	26	2	4	123	1847.0
11	388.8	84.2	1065.8	705.7	244.0	116	34	4	4	158	2408.5
12	566.9	101.7	1279.6	948.8	256.0	129	40	5	4	178	3153.0
13	805.7	120.7	1494.3	1237.1	273.1	153	43	10	5	211	3732.9
14	1083.4	146.6	1763.2	1499.1	300.8	192	53	11	5	261	4793.1
15	1427.8	185.7	2088.6	1734.0	439.6	268	60	12	5	346	5876.7
16	1834.6	238.0	2533.3	1783.5	454.6	362	61	13	5	471	7045.9
17	2370.1	279.9	2973.3	2249.6	473.5	401	62	14	5	482	8386.4
18	3021.7	316.1	3715.3	2550.0	518.8	414	62	14	5	495	10121.9

\$ VALUES ARE BASED ON JULY, 1979 DCI. (WITHOUT PROJECT CONDITIONS)
 SURVEY PERFORMED DURING 1979

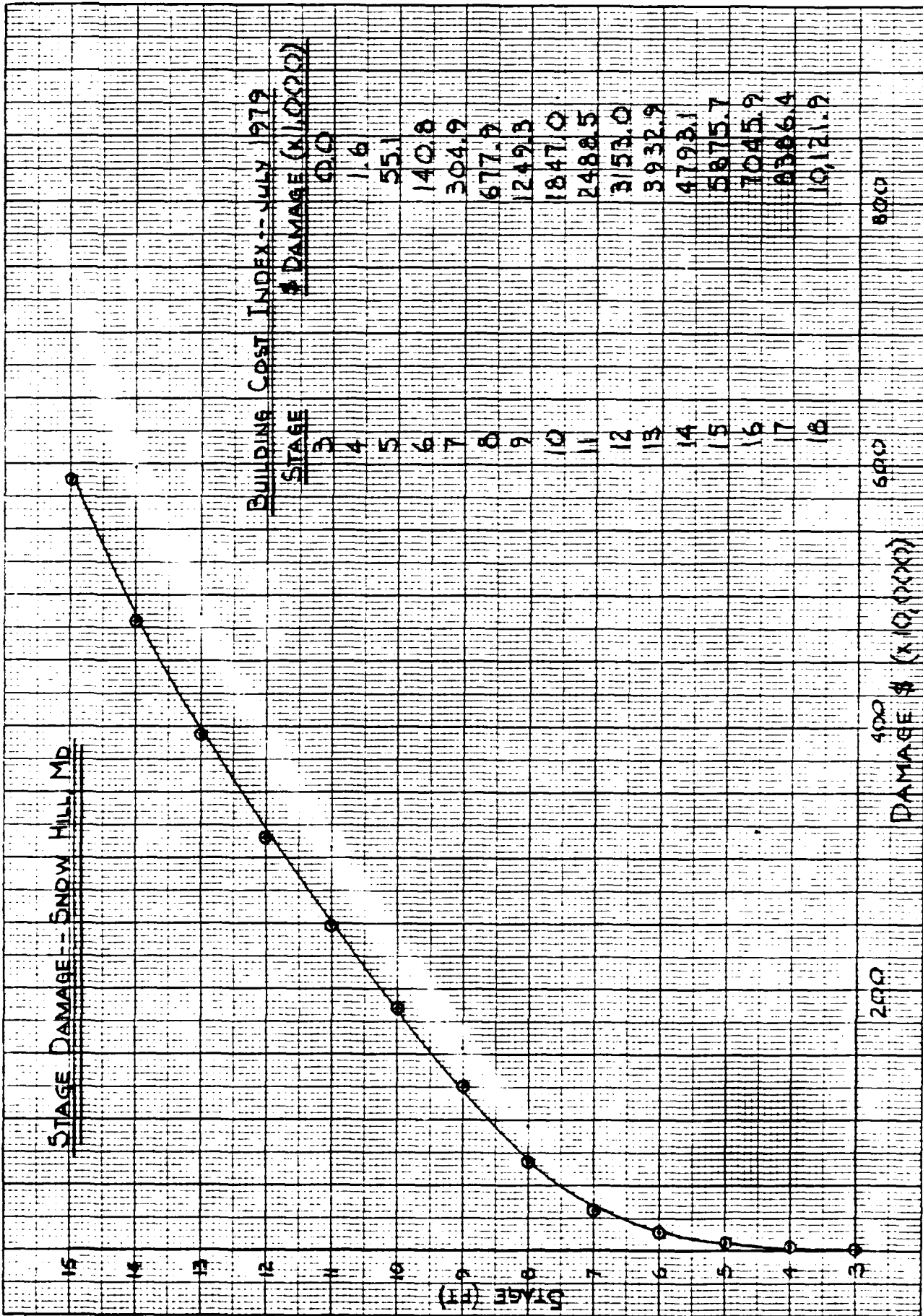

CALCULATION OF AVERAGE ANNUAL DAMAGES		BASIN CHESAPEAKE BAY		REACH SNOW HILL, MD		LT. RT. BANK			
PLANS SH-2 & SH-4		TRIBUTARY POCOMOKE RIVER		UPSTREAM LIMIT OF REACH					
TYPE OF DAMAGE TIDAL FLOODING		STREAM		DOWNSTREAM LIMIT OF REACH					
PRICE LEVEL OF JUL '79	CONDITIONS OF	REFERENCE GAGE OR POINT GULED SH. (VIMS)	DRAINAGE AREA SQ. MI.	COMPUTED BY GMB	DATE 4/15/80	CHECKED BY SKC	DATE 9/80		
FLOOD (1)	DISCHARGE (cfs) (2)	STAGE (Ft.)		FREQUENCY		DAMAGES (Dollars) x 1000		AVE. ANNUAL DAMAGES x 1000	
		RF (3)	MSL (4)	% (5)	Interva. (6)	At Stage (7)	Average (8)	Interval (9)	Summation (10)
			3.0	50	—	0.0	—	—	0.0
			4.0	12	38	1.1	0.55	0.209	0.209
			5.0	4.2	7.8	54.6	27.85	2.172	2.381
			6.0	1.4	2.8	136.2	95.40	2.671	5.053
			7.0	0.45	0.95	296.0	216.10	2.053	7.105
			8.0	0.17	0.28	662.4	479.20	1.342	8.447
			9.0	0.085	0.085	1215.9	939.15	0.798	9.245
			10.0	0.05	0.035	1801.6	1508.75	0.528	9.774
			11.0	0.032	0.018	2432.1	2116.85	0.381	10.155
			12.0	0.023	0.009	3089.3	2760.70	0.248	10.403
			13.0	0.018	0.005	3862.1	3475.70	0.174	10.577
			14.0	0.015	0.003	4718.3	4290.20	0.129	10.706
			15.0	0.014	0.001	5798.0	5258.15	0.053	10.758
			16.0	0.013	0.001	6964.8	6381.40	0.064	10.822
			17.0	0.012	0.001	8303.3	7634.05	0.076	10.898
			18.0	0.011	0.001	10,038.0	9170.65	0.092	10.990
REMARKS:									

CALCULATION OF AVERAGE ANNUAL DAMAGES		BASIN		REACH		LT. RT. BANK									
PLAN SH-6		CHESAPEAKE BAY		SNOW HILL MD		<input type="checkbox"/> <input type="checkbox"/>									
TYPE OF DAMAGE		TERRITORY		UPSTREAM LIMIT OF REACH											
TIDAL FLOODING		POCOMOKE RIVER		DOWNSTREAM LIMIT OF REACH											
PRICE LEVEL OF		REFERENCE GAGE OR POINT		DRAINAGE AREA		COMPUTED BY		DATE		CHECKED BY		DATE			
JUL '79		CONDITIONS OF		GULF SH. (VIMS)		59. MI.		GMB		6/80		ESM		6/80	
FLOOD (1)	DISCHARGE (cfs) (2)	STAGE (Ft.)		FREQUENCY		DAMAGES (Dollars) X 1000		AVE. ANNUAL DAMAGES X 1000							
		RF (3)	MSL (4)	% (5)	Interval (6)	At Stage (7)	Average (8)	Interval (9)	Summation (10)						
			3.0	50		0.0									
			4.0	12	38	0.0	0.0	0.0							
			5.0	4.2	7.8	1.4	0.70	0.055							
			6.0	1.4	2.8	9.0	5.20	0.146							
			7.0	0.45	0.95	280.8	144.90	1.377							
			8.0	0.17	0.28	637.7	459.25	1.286							
			9.0	0.085	0.085	1192.3	915.00	0.778							
			10.0	0.05	0.035	1783.4	1487.85	0.521							
			11.0	0.032	0.018	2426.9	2105.15	0.379							
			12.0	0.023	0.009	3098.4	2762.65	0.249							
			13.0	0.018	0.005	3884.0	3491.20	0.175							
			14.0	0.015	0.003	4745.1	4314.55	0.129							
			15.0	0.014	0.001	5824.6	5284.85	0.053							
			16.0	0.013	0.001	6983.7	6404.15	0.064							
			17.0	0.012	0.001	8316.8	7650.25	0.077							
			18.0	0.011	0.001	10050.2	9183.50	0.092							

REMARKS: DAMAGES REMAINING SH-6

ANNEX F-VI
ST. MICHAELS
STAGE-DAMAGE AND AVERAGE
ANNUAL DAMAGE COMPUTATIONS

F-VI-1

STAGE DAMAGE SUMMARY TABLE (\$ x 1000)

ST. MICHAELS, TALBOT CO., MARYLAND

ELEVATION FLOOR STAGE	2		3		4		5		6		7			8			9		10		11
	TOTAL RESIDENTIAL DAMAGE	TOTAL UTIL, TRANS, PH. DAM.	TOTAL COMMERCIAL DAMAGE	TOTAL PUBLIC DAMAGE	TOTAL INDUSTRIAL DAMAGE	RES.	COMM	PUB.	IND.	TOT.	RES.	COMM	PUB.	IND.	TOT.	FLOOD STAGE	ELEVATION	TOTAL COMMUNITY DAMAGE			
1	0	0	0	0	0	0	0	0	0	0	0	0	0	0	0	1		0			
2	0	0	0	0	0	0	0	0	0	0	0	0	0	0	0	2		0			
3	0	0	0	0	0	0	0	0	0	0	0	0	0	0	0	3		0			
4	0	0.3	17.8	0	2.8	1	2	0	1	4	1	2	0	1	4	4		20.9			
5	0.6	2.0	27.1	0	6.2	3	3	0	1	7	3	0	0	1	7	5		35.9			
6	17.4	8.0	51.5	12.1	17.2	25	4	1	13	33	25	4	1	3	33	6		106.2			
7	87.6	18.1	89.5	44.3	103.6	55	5	2	5	67	55	5	2	5	67	7		345.1			
8	264.4	37.0	168.2	116.3	172.0	105	13	4	5	127	105	13	4	5	127	8		757.9			
9	651.6	102.2	361.8	194.6	264.9	255	49	5	6	315	255	49	5	6	315	9		1575.1			
10	1447.3	176.0	853.5	301.6	374.6	463	73	10	8	554	463	73	10	8	554	10		5173.0			
11	2770.7	301.5	1339.7	411.87	434.1	648	77	12	8	745	648	77	12	8	745	11		8266.7			
12	4481.5	380.7	2165.4	594.4	488.6	684	77	12	10	783	684	77	12	10	783	12		8112.6			
13	6458.3	460.8	3018.5	788.9	549.9	709	78	12	10	807	709	78	12	10	807	13		11276.4			
14	8307.2	524.7	3864.4	924.2	627.6	711	78	12	10	811	711	78	12	10	811	14		14250.1			
15	7848.0	566.1	4474.3	1029.6	680.3	713	78	12	10	813	713	78	12	10	813	15		14590.3			
16	16977.6	593.9	4802.2	1132.3	796.0	713	78	12	10	813	713	78	12	10	813	16		18374.0			

* VALUES ARE BASED ON JULY, 1979 BCI. (WITHOUT PROJECT CONDITIONS)
SURVEY PERFORMED DURING 1979

STAGE DAMAGE-- ST. MICHAELS, MD

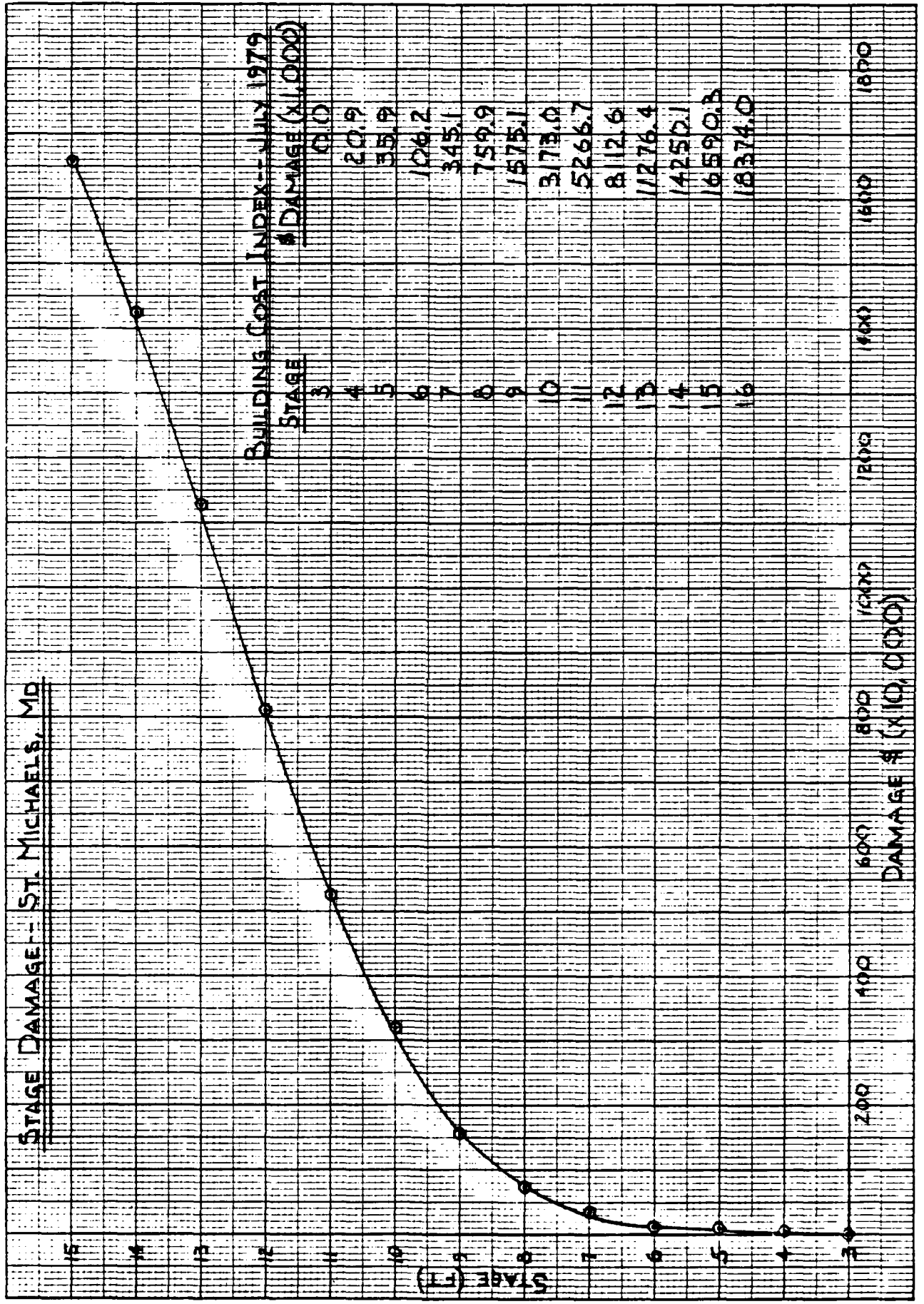

BUILDING COST INDEX-- JULY 1979

STAGE

% DAMAGE (X1,000)

1500 1600 1800

200 400 600 800 1000

DAMAGE \$ (X10,000)

STAGE (X)

3 4 5 6 7 8 9 10 11 12 13 14 15 16

ANNEX F-VII
TILGHMAN ISLAND
STAGE-DAMAGE AND AVERAGE
ANNUAL DAMAGE COMPUTATIONS

F-VII-1

STAGE DAMAGE SUMMARY TABLE (\$ X 1000)
 TILGHMAN ISLAND, TALBOT CO, MD

ELEVATION FLOOR STAGE	TOTAL RESIDENTIAL DAMAGE	TOTAL UTIL, TRANS, P.H. DAM.	TOTAL COMMERCIAL DAMAGE	TOTAL PUBLIC DAMAGE	TOTAL INDUSTRIAL DAMAGE	APPRAISAL COUNT				ELEVATION FLOOD STAGE	TOTAL COMMUNITY DAMAGE
						RES.	COMM	PUB.	IND.		
1	0	0	0	0	0	0	0	0	0	0	0
2	02	03	0	0	0	1	0	0	0	1	0.5
3	37	54	91	0	0	17	3	0	0	20	18.2
4	50.0	15.3	21.2	14.1	0.8	47	4	1	2	54	101.4
5	158.5	34.4	70.5	16.9	0.9	99	10	1	2	112	281.2
6	353.0	62.8	110.4	25.1	24.2	167	11	1	3	182	583.5
7	728.6	92.6	212.2	33.0	36.8	221	12	1	3	237	1104.0
8	1270.0	125.5	307.8	43.0	62.1	275	13	2	3	293	1810.4
9	1744.0	164.4	413.1	84.0	89.0	343	15	5	3	366	2694.5
10	2701.6	207.0	505.7	228.0	105.9	416	20	6	4	446	3748.2
11	3538.3	240.4	620.4	284.3	126.6	445	22	8	4	479	4810.0
12	4351.9	266.0	701.9	357.4	138.0	446	22	8	4	480	5815.2
13	5140.1	289.1	787.4	425.3	159.3	446	22	8	4	480	6801.2
14	5823.7	311.0	880.5	478.0	174.8	446	22	8	4	480	7668.0
15	6435.8	328.7	980.0	498.2	186.0	446	22	8	4	480	8426.7

VALUES ARE BASED ON JULY, 1979 BCI. (WITHOUT PROJECT CONDITIONS)
 SURVEY PERFORMED DURING 1979

STAGE DAMAGE -- TILGHMAN ISLAND, MD

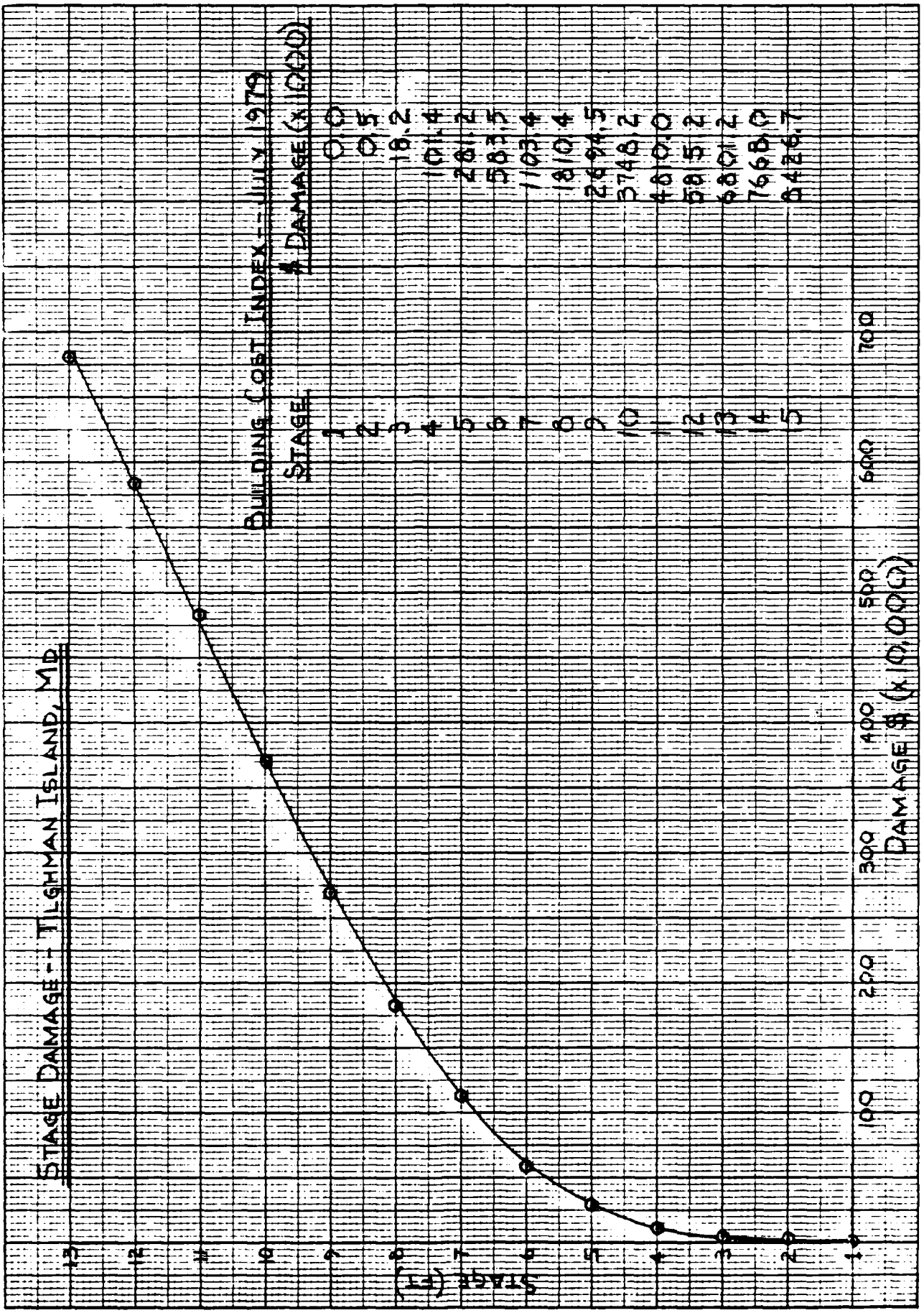

CALCULATION OF AVERAGE ANNUAL DAMAGES:		BASIN CHESAPEAKE BAY	REACH TILGHMAN ISL. MD	LT. RT. <input type="checkbox"/> BANK <input type="checkbox"/>
PLAN TI-5		TRIBUTARY -	UPSTREAM LIMIT OF REACH -	
TYPE OF DAMAGE TIDAL FLOODING		STREAM -	DOWNSTREAM LIMIT OF REACH -	
PRICE LEVEL OF Jul '79	CONDITIONS OF	REFERENCE GAGE OR POINT CHES. BH. (VIMS)	DRAINAGE AREA SQ. MI.	COMPUTED BY DATE GMB 6/80
				CHECKED BY DATE EJM 7/80

FLOOD (1)	DISCHARGE (cfs) (2)	STAGE (Ft.)		FREQUENCY		DAMAGES (Dollars) X 1000		AVE. ANNUAL DAMAGES X 1000	
		RF (3)	MSL (4)	% (5)	Interval (6)	At Stage (7)	Average (8)	Interval (9)	Summation (10)
			1.0	90	-	0.0	-	-	0.0
			2.0	38	52	0.4	0.20	0.104	0.104
			3.0	15	23	8.6	4.50	1.035	1.139
			4.0	6	9	97.4	53.00	4.770	5.909
			5.0	2.5	3.5	273.0	185.20	6.482	12.391
			6.0	1.1	1.4	568.1	420.55	5.888	18.279
			7.0	0.42	0.68	1080.6	824.35	5.606	23.884
			8.0	0.17	0.25	1781.9	1431.25	3.578	27.462
			9.0	0.085	0.085	2661.6	2221.75	1.888	29.351
			10.0	0.047	0.038	3712.1	3186.85	1.211	30.562
			11.0	0.03	0.017	4770.9	4241.50	0.721	31.283
			12.0	0.02	0.01	5772.7	5271.80	0.527	31.810
			13.0	0.016	0.004	6756.4	6264.55	0.251	32.061
			14.0	0.013	0.003	7622.8	7189.60	0.216	32.276
			15.0	0.012	0.001	8381.1	8001.95	0.080	32.356

REMARKS:
DAMAGES REMAINING TI-5

END

FILMED

1-86

DTIC