

40-A161 SSS

A CONDITIONAL SAMPLING MODULE FOR THE TEE LASER DOPPLER
ANEMOMETER COUNTER PROCESSOR (U) AERONAUTICAL RESEARCH
LABS MELBOURNE (AUSTRALIA) W H MARCH JUL 85

1/1

UNCLASSIFIED

ARL/ACRO-PROP-TM-828

F/G 14/2

ML

END
DATE
FREQ
80

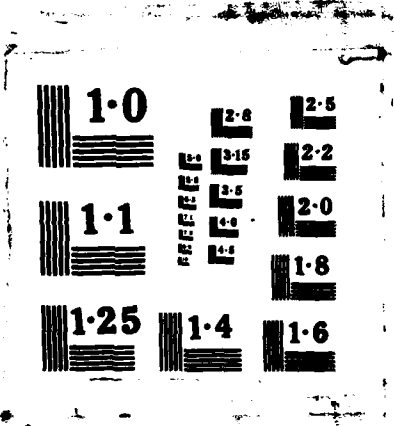

1.0

1.1

1.25

E
E
E
E
E

1.4

2.8

3.15

3.5

4.0

4.5

2.5

2.2

2.0

1.8

1.6

UNCLASSIFIED

12

ASE-AERO-PROP-TM-428

AR-004-036



DEPARTMENT OF DEFENCE
DEFENCE SCIENCE AND TECHNOLOGY ORGANISATION
AERONAUTICAL RESEARCH LABORATORIES
MELBOURNE, VICTORIA

Aero Propulsion Technical Memorandum 428

A CONDITIONAL SAMPLING MODULE FOR THE TSI LASER
DOPPLER ANEMOMETER COUNTER PROCESSOR

by

Warren H. HARCH

DTIC
ELECTE
NOV 26 1985
S
D

Approved for Public Release

THE UNITED STATES NATIONAL
TECHNICAL INFORMATION SERVICE
IS AUTHORISED TO
REPRODUCE AND SELL THIS REPORT

(C) COMMONWEALTH OF AUSTRALIA 1985

JUN 1985

UNCLASSIFIED 1 1 21-85 085

AD-A161 555

DTIC FILE COPY

AR-004-036

DEPARTMENT OF DEFENCE
DEFENCE SCIENCE AND TECHNOLOGY ORGANISATION
AERONAUTICAL RESEARCH LABORATORIES

Aero Propulsion Technical Memorandum 428

A CONDITIONAL SAMPLING MODULE FOR THE TSI LASER
DOPPLER ANEMOMETER COUNTER PROCESSOR

by

Warren H. HARCH

SUMMARY

A module is described that is fully compatible with TSI Laser Doppler Counter Processors and Interfaces and which, when installed, permits conditional sampling of the TSI Laser Doppler Anemometer Output at some predetermined cyclic or externally imposed rate.



(C) COMMONWEALTH OF AUSTRALIA 1985

POSTAL ADDRESS: Director, Aeronautical Research Laboratories,
P.O. Box 4331, Melbourne, Victoria, 3001, Australia.

CONTENTS

	PAGE NO.
1. BACKGROUND	1
2. INTERFACE PRINCIPLES	1
2.1 Introduction	1
2.2 TSI 1990 Counter	2
2.3 TSI 1998 Master Interface	2
2.4 ARL Conditional Interface	2
3. CONSTRUCTION AND OPERATIONS	3
4. CONFIGURATIONS	4
5. ACKNOWLEDGEMENT	5
REFERENCES	
FIGURES	
DISTRIBUTION	
DOCUMENT CONTROL DATA	

Accession For	
NTIS CRA&I	<input checked="" type="checkbox"/>
DTIC TAB	<input type="checkbox"/>
Unannounced	<input type="checkbox"/>
Justification	
By _____	
Distribution / _____	
Availability Codes	
Dist	Avail and/or Special
A-1	



1. BACKGROUND

Laser Doppler Anemometry (LDA) is a well established flow measurement technique, having the advantages of being non-intrusive and calibration-free, with high spatial and temporal resolution. A significant disadvantage of the technique, however, is the existence of velocity biasing problems associated with highly turbulent flows, and density biasing problems which arise in turbulent combusting flows. The majority of these biases can be eliminated with good optics and frequency shifting of the laser beam.

One bias problem remains, due to the fact that a laser doppler anemometer measures instantaneous velocities of individual particles. Measurement of a large number of particle velocities allows the calculation of statistical quantities that describe the average particle flow. However, turbulent flow processes are conventionally described in terms of time-averaged velocity components and velocity correlations, which generally differ from the above particle-averaged quantities since, for an uniformly seeded flow, the particle arrival rate is dependent on the flow velocity. Several correction schemes^(1,2) have been proposed to remove this bias, but modern techniques tend to favour some form of conditional sampling^(3,4,5), such that the velocity sampling of the flow is not controlled by the particle arrival rate. The ability to impose conditional sampling is also of value in synchronizing measurements of velocity with external events having periodicity, such as occur in rotating machinery or reciprocating engines.

A common method for obtaining conditionally sampled data involves recording both the raw data and a synchronizing signal, and post-processing the data according to the required algorithm. However, in a typical LDA measurement the conditioned data might represent less than 1% of validated data points, and the above process can result in unacceptable computational overheads. The device described below enables conditional sampling which is controlled either externally or by an internally generated pulse rate. When the internal pulse rate is used to control sampling, the sampling frequency is set at least 2 orders lower than the particle arrival rate so that the fluid-velocity can be considered to be sampled at fixed intervals and therefore free of bias. Data are passed to the computer at the sampling rather than the particle arrival rate and excessive overheads are therefore avoided.

The device has been designed for use with TSI LDA system and configured for the HP-9825A computer.

2. INTERFACE PRINCIPLES

2.1 Introduction

The ARL 60 105 conditional interface is designed as an add-on component to the TSI 1998 Master Interface, and enables DMA (Direct Memory Access) transfer of the data from the TSI 1998 Master Interface to the Hewlett Packard 9825A Computer via the HP 98032A interface. The general arrangement is shown in Figure 1. Details of operation of the TSI 1990,

HP 98032A and HP 9825A are to be found in relevant manuals^(6,7,8). A brief description only is included here for convenience.

2.2 TSI 1990 Counter

Each time a velocity data point is validated and latched into the output register, the TSI 1990 counter generates the following output:

- (a) 16 Bit time output
- (b) 8 Bit cycle count output
- (c) 1 Bit data ready pulse.

The cycle count plus the time output together determine the doppler frequency, although the latter is sufficient information if the counter is operating in the fixed N cycle mode.

2.3 TSI 1998 Master Interface

The 1998 Master Interface uses the above information to generate two 16 Bit words for each counter in the system and transfers this information in bit parallel, word serial form to the computer. The interface also generates a third word representing time between data points (TBD). The words contain the following information:

- (a) Word A: 8 bit cycle count, 2 bit processor address, 1 bit counter mode, 1 bit first transfer after synchronizing pulse.
- (b) Word B: 16 bit time output.
- (c) Word TBD: 16 bit time between data points.

Three bits are used to control the data transfer handshake between the interface and the computer. The interface will always transmit word B. Words A and TBD are optional.

The interface may operate in one of two modes - random or coincidence. In random mode the interface will transmit data from a counter each time it receives a "data ready" pulse from that counter. In coincidence mode, the data is transferred only if all counters in the system generate a "data ready" pulse within a previously programmed coincidence interval.

2.4 ARL Conditional Interface

The Conditional Interface (Fig. 2) operates in two modes - Active and Internal Rate. In the internal rate mode the data is transferred directly from the master interface to the computer, the sole function of the conditional interface being to enable the correct handshake between the master interface and the computer.

In active mode the sampling frequency is controlled by either an internally or an externally generated square wave in the following manner. During normal operations and upon receipt of a data ready pulse

from the counter, the TSI 1998 interface imposes an inhibit on the TSI 1990 counter to prevent updating of the output registers during the data transfer operation. The circuit has been modified to prevent this inhibit from being cleared until the next rising edge of the sampling frequency square wave following completion of the data transfer. The maximum data rate from the counter is therefore equal to the prescribed sampling frequency although the actual rate may be less than this. The internally generated sampling frequency is periodic and continuously variable in the range of 650 kHz to 0.03 Hz.

The sampling frequency also generates a synchronising pulse which may be inserted in either the internal rate or active mode to enable determination of the temporal relationship between data points and the event generating the synchronizing pulse.

3. CONSTRUCTION AND OPERATIONS

Detailed drawings for the conditional interface are described in ARL Series Parts List No. 60105-A2, portions of which are reproduced in Figure 3.

Figure 4 shows the minor rework necessary to the TSI 1998 interface to enable operation of the conditional interface. Supply voltage for the conditional interface has been connected to Pin 30. A second J-K flip flop (U76) has been inserted in the data hold (counter inhibit) circuit and the data between this flip flop and the original data hold flip flop is formed external to the interface through pins 46 and 50 on connector J2.

A second modification (Fig. 4, U41) was incorporated to correct a logic error that occurred in the TSI 1998 interface when programmed to transfer only Words A and B. In the unmodified condition the 'First after Synch' bit of Word A would latch only on every second validated data transfer from the counter unless more than one data transfer occurred between synchronizing pulses.

A jumper connected between pins 46 and 50 will enable the TSI 1998 interface to operate in its unmodified mode.

Figure 5 shows the timing diagram for a three word data transfer in the conditional sampling mode. This timing diagram should be read in conjunction with relevant interface and computer manuals. (7,8)

Control line 0 (CTL 0) of the 9825A computer is connected to the ST11 line on the conditional interface. This line enables software control of the sampling mode according to the truth table below.

Initiation of a DMA transfer by the computer drives the PCTL line on the 98025A interface high (PCTL set) which subsequently activates the TSI 1998 interface via the COMMAND line.

When the TSI 1990 counter has data to send to the computer it sends the data together with a "data ready" (DR) pulse to the TSI 1998 interface. The interface responds by sending a DATA HOLD (DH2) to the counter, inhibiting further updating by the counter.

		CTL 1 (ST11) LINE	
		TRUE = LOW	FALSE = HIGH
F S U W N I C T T C O H I N	ACTIVE	CONDITIONAL SAMPLING RATE	INTERNAL
	INTERNAL RATE	INTERNAL RATE	INTERNAL RATE
FIG. 2		SAMPLING MODE	

The TSI 1998 interface sends a flag pulse to the HP98032A interface which responds with a level change (PCTL CLEAR) and acceptance by the computer of the data. When the computer is ready for the next word PCTL is changed from "CLEAR" to "SET" and the transfer cycle can be repeated.

When the required number of words for the data point have been transmitted by the TSI 1998 interface the CLR DH1 is activated, clearing the master interface and releasing DH1. The next rising edge of the square wave generates CLR DH2 which releases DH2 (DATA HOLD) and the 1990 counter is free to accept a new data point. If the DMA transfer is incomplete the PCTL line will be reset and the cycle repeated.

If the DMA transfer is completed the control line CTL 0 is usually released (BO-00 High) and the counter allowed to run free. If only one word is read per data measurement a further Low-High transition is required on the BO-00 since an alternative circuit is used to clear the Master Interface.

4. CONFIGURATIONS

For operation as outlined in this technical memorandum the following configurations apply.

(a) TSI 2998 Master Interface

Dip switch I.C. Location U25 on PC2605252

(5)

<u>Switch No.</u>	<u>State</u>
1	As required
2	As required
3	As required
4	Not used
5	ON
6	OFF
7	ON
8	Not used

Rotary Switch and Dip switch at IC location on PC2605251 to be set as required.

(b) HP98032A interface

The following configuration jumpers are installed to obtain correct logic.

3, 7, 9, B, D

(c) HP9825A Computer

When operating in DMA mode the following considerations apply.

: To transfer M words from peripheral "2" to buffer "ONE" execute
eir2,1;tfr2,"ONE",M;eir2,0

: The TSI 1998 and HP98032A use complementary logic. To read a binary word from buffer "ONE" execute the following statement
cmprdb"ONE".

5. ACKNOWLEDGEMENT

The author wishes to acknowledge the assistance of Mr G. Forsyth in the design and Mr K. Vaughan in the construction of this circuit.

REFERENCES

1. McLaughlin, D.K. and Tiederman, W.G., Physics of Fluids, Vol.16 No.12, 1973.
2. Roesler, I., Stevenson, W.H. and Thomson H.D., "Investigation of Bias Errors in Laser Doppler Velocimeter Measurements", AFWAL-TR-80-2108 Dec 1980.
3. Stevenson, W.H., Thomson, H.D. and Luchik, T.S. "Laser Velocimeter Measurements and Analysis in Turbulent Flows with Combustion", AFWAL-TR-82-2076 Part 1, Sept 1982.
4. Stevenson, W.H., Thomson, H.D. and Gould, R.D., "Laser Velocimeter Measurements and Analysis in Turbulent Flows with Combustion", AFWAL-TR-82-2076 Part II, July 1983.
5. Craig, R.R., Nejad, A.S., Hahn, E.Y. and Schwartzkopf, K.G., "A general approach for obtaining unbiased LDV data in highly turbulent nonreacting and reacting flows". AIAA-84-0366 January 1984.
6. TSI Incorporated Instruction Manual Model 1990 Counter Type Signal processor for Laser Velocimeter.
7. TSI Incorporated P/N 1990165. Instruction Manual Model 1998 Master Interface.
8. Hewlett-Packard 98032A 16-Bit Interface Installation and Service Manual.

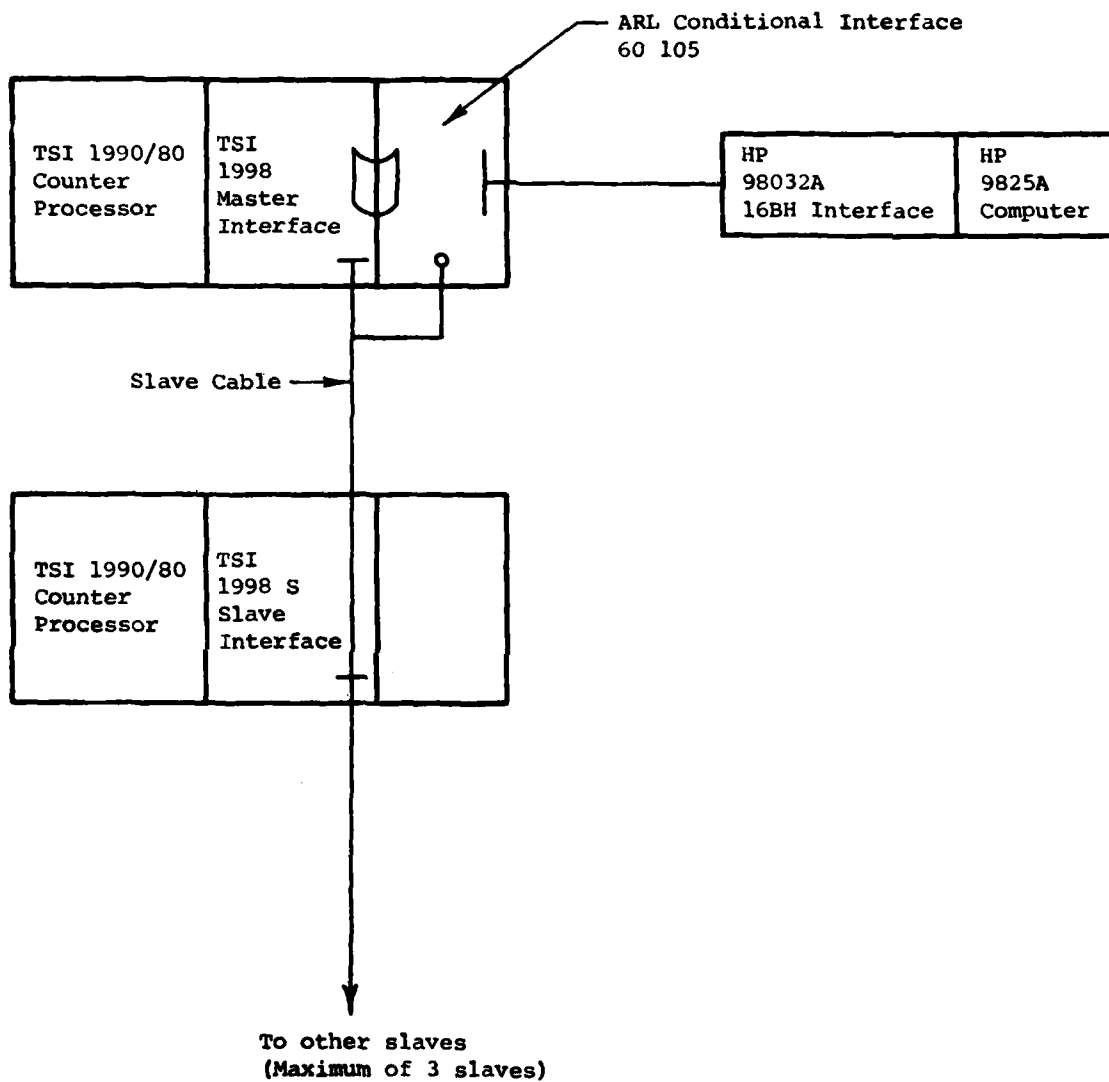

FIG. 1 SYSTEM ARRANGEMENT OF COUNTER PROCESSORS, INTERFACES, AND COMPUTER

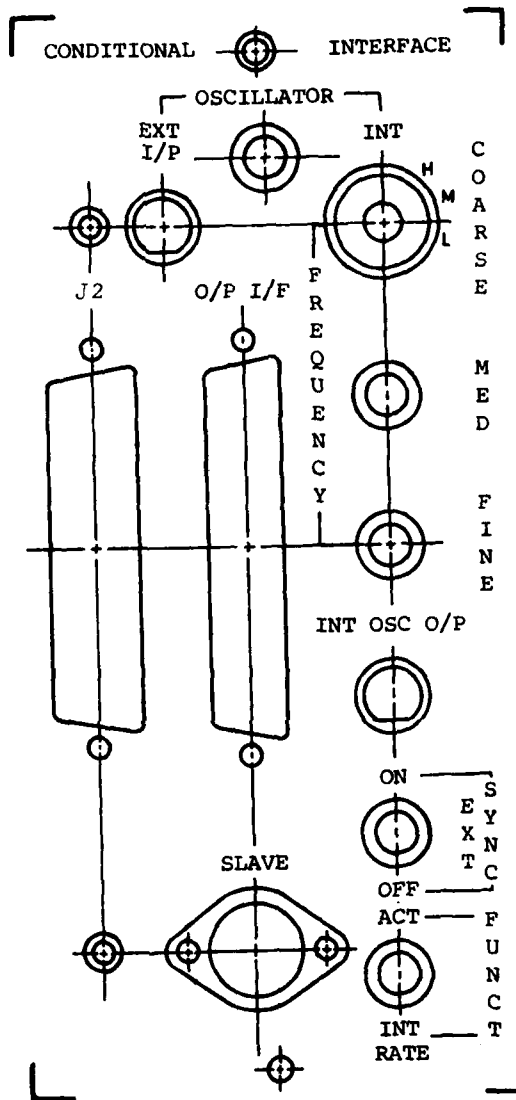
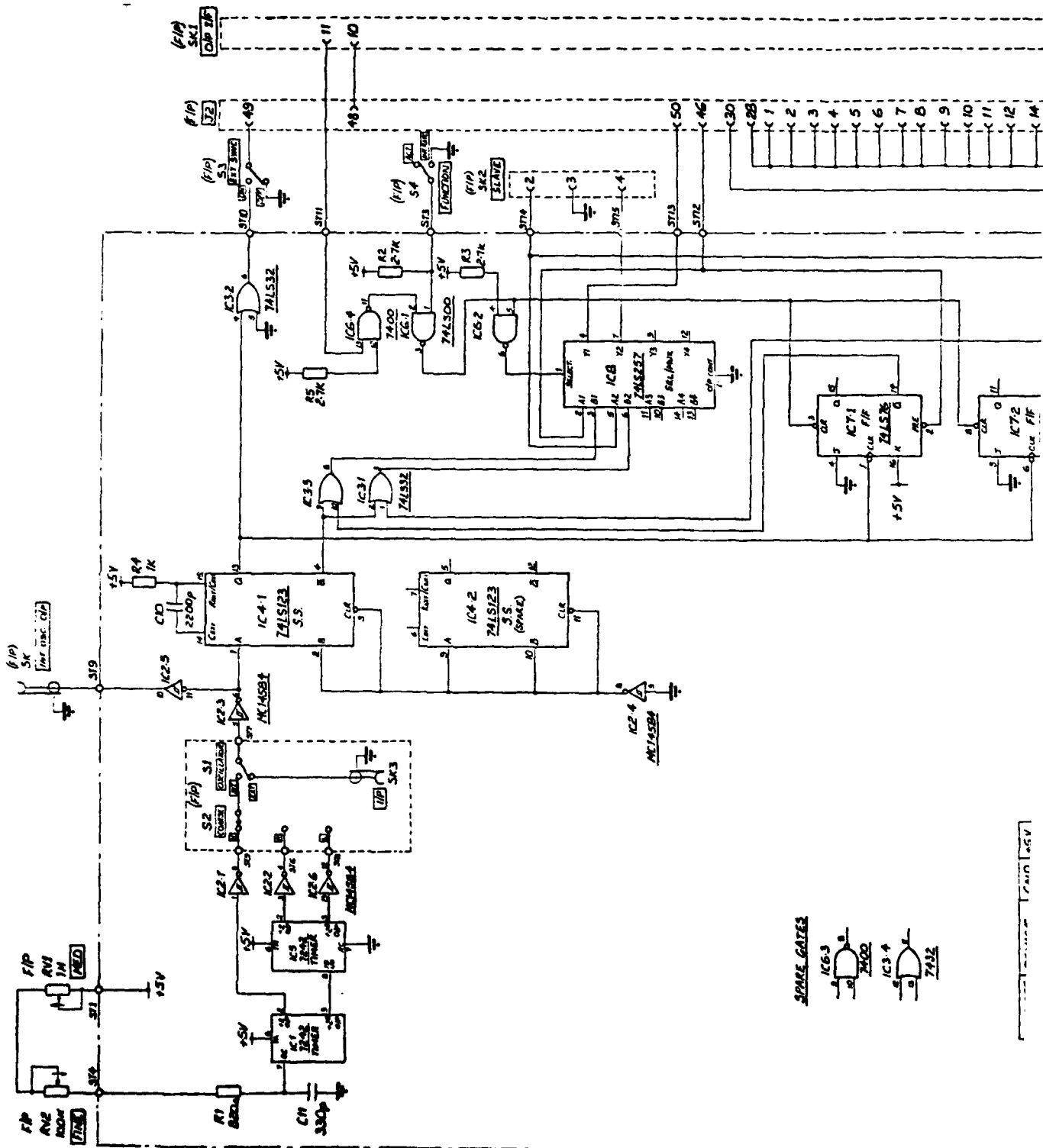

FIG. 2 CONDITIONAL INTERFACE FRONT PANEL



SPARE GATES
 IC 6-3 7400
 IC 3-4 7400
 74LS20

74LS20

SOME GATES



CCT REF	DEVICE	GND	+5V
K1.5	KM72A2	4	1
K2	MC17504	7	14
K4	SN74LS123	8	16
K6	SN74LS00	7	14
K7	SN74LS176	13	3
K8	SN74LS87	8	16
K3	SN74LS32	7	14

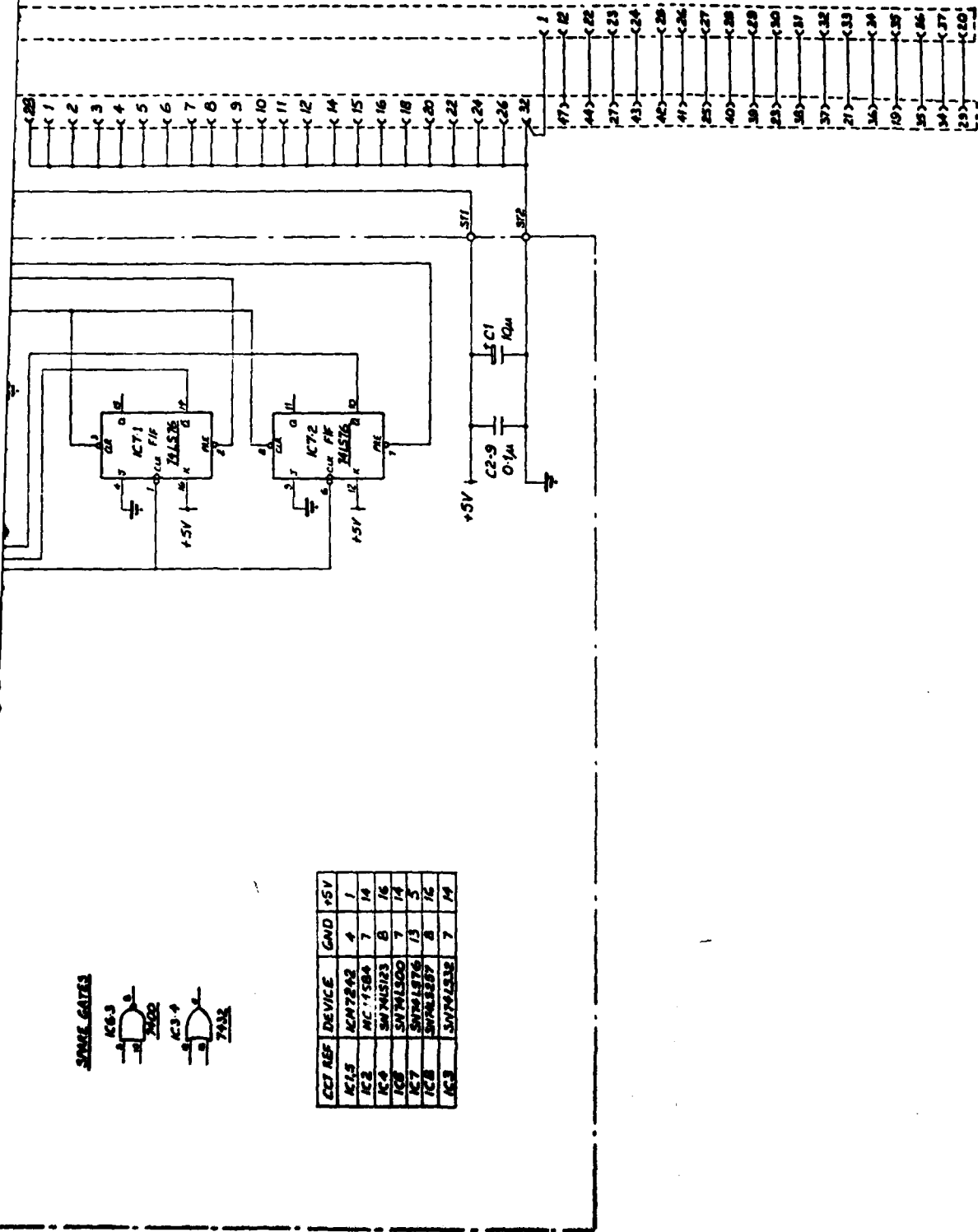
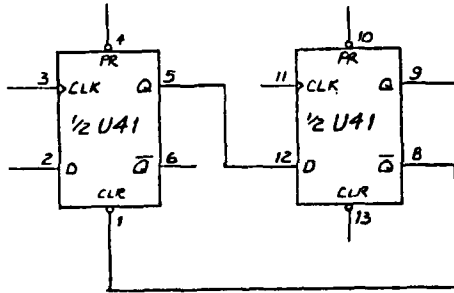
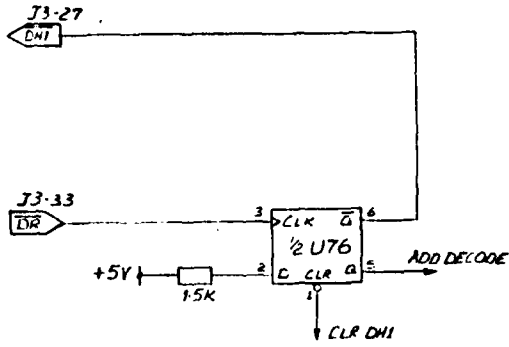

FIG. 3 ARL CONDITIONAL INTERFACE CIRCUIT

STANDARD CCT IN 1998 M



MODIFIED CCT FOR 1998 M/S

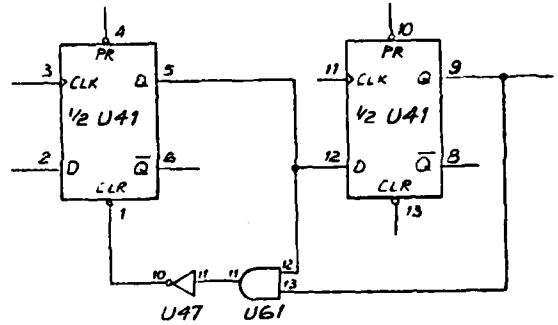
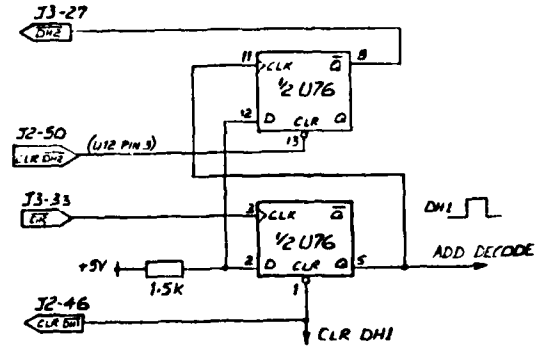

FIG. 4 TSI 1998 INTERFACE CIRCUIT CHANGES

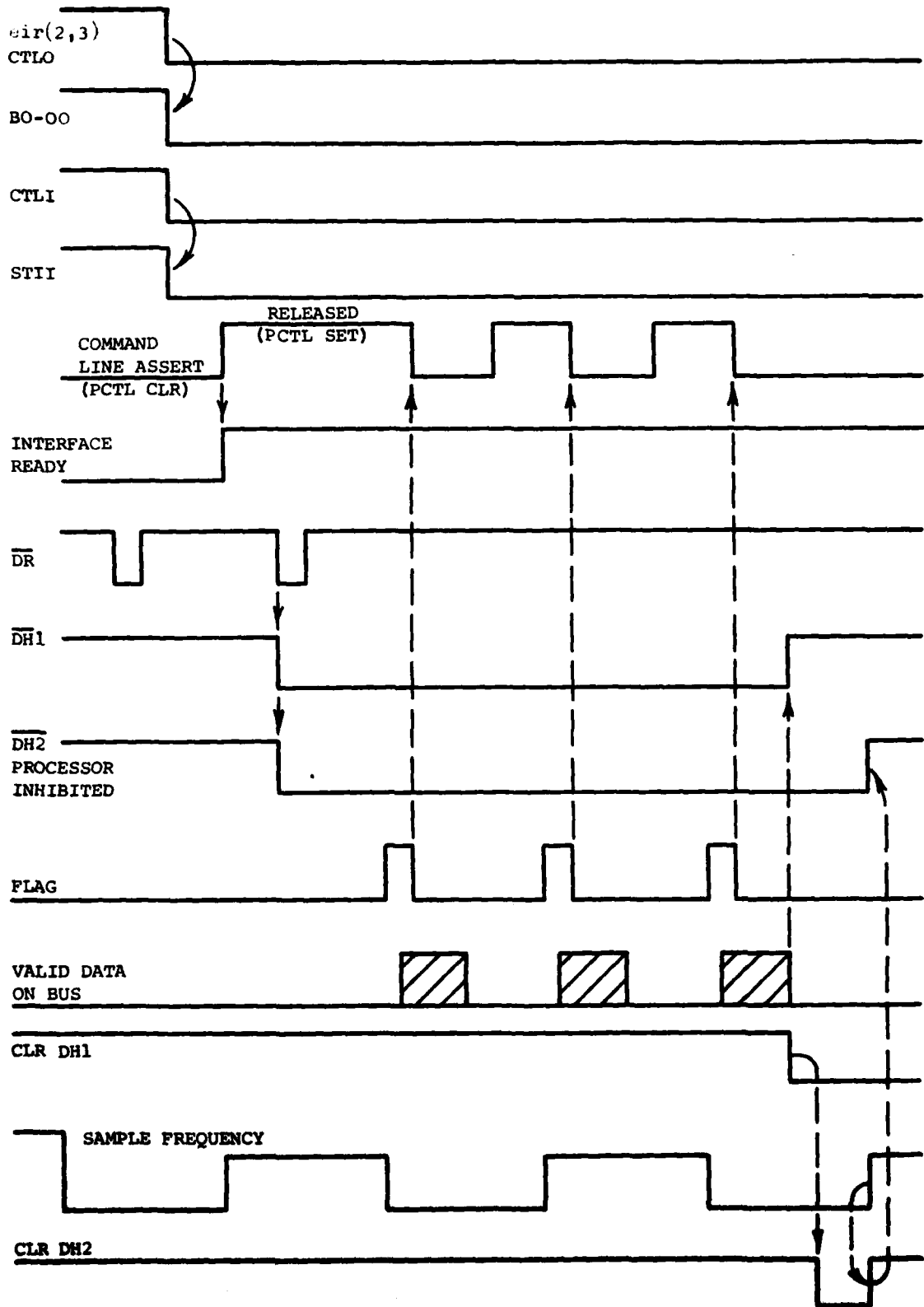

FIG. 5 TIMING DIAGRAM FOR A THREE WORD MEASUREMENT DATA TRANSFER IN CONDITIONAL MODE

DISTRIBUTION

AUSTRALIA

Department of Defence

Defence Central

Chief Defence Scientist)
Deputy Chief Defence Scientist)
Superintendent, Science and Program Administration) 1 copy
Controller, External Relations, Projects & Analytical Studies)
Defence Science Adviser (UK) (Doc Data sheet only)
Counsellor, Defence Science (USA) (Doc Data sheet only)
Defence Central Library
Document Exchange Centre, DISB (18 copies)
Joint Intelligence Organisation
Librarian H Block, Victoria Barracks, Melbourne
Director General - Army Development (NSO) (4 copies)

Aeronautical Research Laboratories

Director
Library
Superintendent - Aero Propulsion
Divisional File - Aero Propulsion
Author: W.H. Harch
G.F. Forsyth
A.P. Cox
A. Farrell
N. Pollock

Materials Research Laboratories

Director/Library

Defence Research Centre

Library

Navy Office

Navy Scientific Adviser
RAN Aircraft Maintenance and Flight Trials Unit
Directorate of Naval Aircraft Engineering
Directorate of Naval Aviation Policy
Superintendent, Aircraft Maintenance and Repair
Directorate of Naval Ship Design

Army Office

Scientific Adviser - Army
Engineering Development Establishment, Library
Royal Military College Library
US Army Research, Development and Standardisation Group

DISTRIBUTION (cont.)

Air Force Office

Air Force Scientific Adviser
Aircraft Research and Development Unit
Scientific Flight Group
Library
Technical Division Library
Director General Aircraft Engineering - Air Force
Director General Operational Requirements - Air Force
HQ Operational Command (SMAINTSO)
HQ Support Command (SLENGO)
RAAF Academy, Point Cook

Central Studies Establishment

Information Centre

Government Aircraft Factories

Manager
Library

Department of Science and Technology

Bureau of Meteorology, Library

Department of Aviation

Library
Flying Operations and Airworthiness Division

Statutory and State Authorities and Industry

Australian Atomic Energy Commission, Director
SEC of Vic., Herman Research Laboratory, Library
Ansett Airlines of Australia, Library
BHP, Melbourne Research Laboratories
Commonwealth Aircraft Corporation, Library
Hawker de Havilland Aust Pty Ltd, Bankstown, Library

Universities and Colleges

Adelaide	Barr Smith Library Professor of Mechanical Engineering
Flinders	Library
LaTrobe	Library
Melbourne	Engineering Library
Monash	Hargrave Library
Newcastle	Library

DISTRIBUTION (cont.)

Universities and Colleges (cont.)

Sydney	Engineering Library
NSW	Physical Sciences Library Professor R.A.A. Bryant, Mechanical Engineering
Queensland	Library
Western Australia	Library Associate Professor J.A. Cole, Mechanical Engineering
RMIT	Library

SPARES (10 copies)

TOTAL (92 copies)

DOCUMENT CONTROL DATA

AD-A161555

1. a. AR No AR-004-036	1. b. Establishment No ARL-AERO-PROP-TM-428	2. Document Date JULY 1985	3. Task No DST 82/049
4. Title A CONDITIONAL SAMPLING MODULE FOR THE TSI LASER DOPPLER ANEMOMETER COUNTER PROCESSOR		5. Security a. document UNCLASSIFIED b. title c. abstract U U	6. No Pages 8 7. No Refs 8
8. Author(s) Warren H. Harch		9. Downgrading Instructions	
10. Corporate Author and Address Aeronautical Research Laboratories P.O. Box 4331, Melbourne Vic 3001		11. Authority (as appropriate) a. Sponsor b. Security c. Downgrading d. Approval	
12. Secondary Distribution (of this document) Approved for Public Release			
Overseas enquirers outside stated limitations should be referred through ASDIS, Defence Information Services Branch, Department of Defence, Campbell Park, CANBERRA ACT 2801			
13. a. This document may be ANNOUNCED in catalogues and awareness services available to ... No limitations			
13. b. Citation for other purposes (ie casual announcement) may be (select) unrestricted (or) as for 13 a.			
14. Descriptors Laser doppler velocimeters; Data sampling, Australia		15. COBATI Group 14020 20040 20050	
16. Abstract A module is described that is fully compatible with TSI Laser Doppler Counter Processors and Interfaces and which, when installed, permits conditional sampling of the TSI Laser Doppler Anemometer Output at some predetermined cyclic or externally imposed rate. <i>keywords:</i>			

This page is to be used to record information which is required by the Establishment for its own use but which will not be added to the DISTIS data base unless specifically requested.

16. Abstract (Contd)		
17. Imprint Aeronautical Research Laboratories, Melbourne.		
18. Document Series and Number Aero Propulsion Technical Memorandum 428	19. Cost Code 42 3645	20. Type of Report and Period Covered
21. Computer Programs Used		
22. Establishment File Ref(s)		

END

DATE
FILMED

-86