

MICROCOPY RESOLUTION TEST CHART
NATIONAL BUREAU OF STANDARDS-1963-A

2

AD-A161 570



A DYNA-METRIC ANALYSIS OF BASE
 AWAITING PARTS (AWP) SENSITIVITY
 TO DEPOT REPAIR CYCLE VARIABLES

THESIS

Lewis E. Huber, M.S.
 Major, USAF

AFIT/GLM/LSM/85S-37

DISTRIBUTION STATEMENT A
 Approved for public release
 Distribution Unlimited

DTIC
ELECTE
 NOV 21 1985

DTIC FILE COPY

DEPARTMENT OF THE AIR FORCE
 AIR UNIVERSITY
AIR FORCE INSTITUTE OF TECHNOLOGY

Wright-Patterson Air Force Base, Ohio

85 11 18 120

AFIT/GLM/LSM/85 **S-37**

A DYNA-METRIC ANALYSIS OF BASE
AWAITING PARTS (AWP) SENSITIVITY
TO DEPOT REPAIR CYCLE VARIABLES

THESIS

Lewis E. Huber, M.S.
Major, USAF

AFIT/GLM/LSM/85S-37

S DTIC
ELECTE **D**
NOV 21 1985
B

Approved for public release; distribution unlimited

The contents of the document are technically accurate, and no sensitive items, detrimental ideas, or deleterious information are contained therein. Furthermore, the views expressed in the document are those of the author(s) and do not necessarily reflect the views of the School of Systems and Logistics, the Air University, the United States Air Force, or the Department of Defense.

Accession For	
NTIS	<input checked="" type="checkbox"/>
DTIC	<input type="checkbox"/>
Unannounced	<input type="checkbox"/>
Justification	<input type="checkbox"/>
By _____	
Distribution _____	
Availability _____	
Dist	Special
A-1	



AFIT/GLM/LSM/85S-37

A DYNA-METRIC ANALYSIS OF BASE
AWAITING PARTS (AWP) SENSITIVITY
TO DEPOT REPAIR CYCLE VARIABLES

THESIS

Presented to the Faculty of the School of Systems and Logistics
of the Air Force Institute of Technology
Air University
In Partial Fulfillment of the
Requirements for the Degree of
Master of Science in Logistics Management

Lewis E. Huber, M.S.

Major, USAF

September 1985

Approved for public release; distribution unlimited

Acknowledgements

The completion of this thesis would not have been possible without the guidance and assistance of numerous people. Major Gene Lindsey, of the Air Force Logistics Management Center provided the initial impetus for the study, and helped guide the data collection effort. Mike Nicklas and Barbara Wieland of HQ AFLC/XRSA assisted greatly in using the Dyna-METRIC model. My advisor, Richard D. Mabe and reader, Michael J. Budde provided the necessary direction and needed support throughout the long, arduous process. Finally, I'd like to express my appreciation to my family who have shown great patience and provided continued support.

Table of Contents

	Page
Acknowledgements	ii
List of Figures	v
List of Tables	vi
Abstract	viii
I. Introduction	1
Background	1
Justification	3
Specific Problem	3
Research Proposal	4
Research Objectives	4
Investigative Questions	4
Scope and Limitations of Research	5
II. Literature Review	6
Overview	6
Terms and Definitions	6
Recoverable Item Management	7
Repair Cycle Asset Control	9
Reparable Item Inventory Models	11
METRIC	11
Mod-METRIC	13
Dyna-METRIC	14
Summary	15
III. Methodology	17
Overview	17
Dyna-METRIC Overview	18
Model Description	19
Model Assumptions and Limitations	21
Research Data Base	24
Data Collection/Preparation	26
Data Assumptions	27
Scenario	29
Repair Process Variables	30
Experimental Design	31
Procedure	34
Methodology Limitations	35

	page
IV. Results	36
Overview	36
Interpretation of Output	37
Methodology Modifications	38
Presentation and Analysis of Research Question 1	40
Presentation and Analysis of Research Question 2	41
Depot Shop Flow	43
Reparable Intransit Days	46
Supply to Maintenance Days	48
Serviceable Turn-in Days.	50
Presentation and Analysis of Research Question 3	52
Presentation and Analysis of Research Question 4	54
Summary of Results	55
V. Summary, Conclusions, and Recommendations . . .	58
Overview	58
Summary of Research Effort	58
Conclusions	60
Research Question 1	60
Research Question 2	61
Research Question 3	62
Research Question 4	63
Recommendations	63
Appendix A: Glossary	66
Appendix B: KC-135A AWP Summary	68
Appendix C: Reparable Asset Control	69
Appendix D: World Wide Stock Levels	70
Appendix E: Input Stock Levels	72
Appendix F: Input Data Source Summary	74
Appendix G: Depot Repair Cycle Baseline Input File .	76
Appendix H: Depot Repair Limit Data File	78
Appendix I: Dyna-METRIC Input Files	80
Appendix J: Sensitivity Analysis Results	88
Bibliography	114
VITA	116

List of Figures

Figure	Page
1. General Recoverable Item Flows	8
2. Dyna-METRIC View of the World	19
3. General Math Model	21
4. System Variables Subjected to Analysis	30
5. Aggregate AWP Results (sample)	32
6. Variable Impact on Individual LRUs (sample)	33
7. Variable Impact on Capability (sample)	34
8. Computation of the Expected Total Pipeline Length	42

List of Tables

Table	Page
I. Dyna-METRIC Options	22
II. Depot Shop Flow Impact	44
III. DSF Reduction Impact on Individual LRUs	45
IV. Repairable Intransit Days Impact	47
V. Supply to Maintenance Days Impact	49
VI. Serviceable Turn-in Days Impact	51
VII. Expected Rates: % NFMC Aircraft	53
VIII. Peacetime Scenario Baseline	88
IX. 25% Reduction DSF - Peacetime Scenario	89
X. 50% Reduction DSF - Peacetime Scenario	90
XI. 75% Reduction DSF - Peacetime Scenario	91
XII. 25% Reduction RIT - Peacetime Scenario	92
XIII. 50% Reduction RIT - Peacetime Scenario	93
XIV. 75% Reduction RIT - Peacetime Scenario	94
XV. 25% Reduction SMX - Peacetime Scenario	95
XVI. 50% Reduction SMX - Peacetime Scenario	96
XVII. 75% Reduction SMX - Peacetime Scenario	97
XVIII. 25% Reduction TRN - Peacetime Scenario	98
XIX. 50% Reduction TRN - Peacetime Scenario	99
XX. 75% Reduction TRN - Peacetime Scenario	100
XXI. Wartime Scenario Baseline	101
XXII. 25% Reduction DSF - Wartime Scenario	102
XXIII. 50% Reduction DSF - Wartime Scenario	103

Table	Page
XXIV. 75% Reduction DSF - Wartime Scenario	104
XXV. 25% Reduction RIT - Wartime Scenario	105
XXVI. 50% Reduction RIT - Wartime Scenario	106
XXVII. 75% Reduction RIT - Wartime Scenario	107
XXVIII. 25% Reduction SMX - Wartime Scenario	108
XXIX. 50% Reduction SMX - Wartime Scenario	109
XXX. 75% Reduction SMX - Wartime Scenario	110
XXXI. 25% Reduction TRN - Wartime Scenario	111
XXXII. 50% Reduction TRN - Wartime Scenario	112
XXXIII. 75% Reduction TRN - Wartime Scenario	113

Abstract

The efficient operation of the repair/resupply system for Air Force recoverable items is essential for maintaining weapon systems at a viable readiness level. Large AWP inventories at the base level indicate items are remaining unserviceable for long periods of time, awaiting depot supplied spare parts. Dyna-METRIC, the most current inventory model used by the Air Force, is capable of assessing the impact of varying levels of depot support on base AWP and weapon system capability. Dyna-METRIC was used to model eleven KC-135A components and their reparable sub-units, to assess the sensitivity of base AWP to four depot repair cycle variables. The results indicated large improvements in any single depot repair cycle variable was necessary to produce noticeable AWP and capability improvements. Additionally, it was shown that the amount of AWP reduction that is caused by improving a given variable varied among LRUs. Specific recommendations for improving AWP for the 11 KC-135A LRUs, as well as recommendations for further research, are given.

A DYNA-METRIC ANALYSIS OF BASE
AWAITING PARTS (AWP) SENSITIVITY
TO DEPOT REPAIR CYCLE VARIABLES

I. Introduction

Background

The level of sophistication and complexity apparent in today's weapon systems reflects a longstanding national belief in strength through technological superiority. As weapon systems are retired, they are frequently replaced by systems of greater technical complexity and superior capability. Their high cost, coupled with improved capability per unit, leads to replacement of the retired system with fewer units. The logistician's problem of maintaining capability is thus compounded. He must maintain a more complex system, at a higher state of readiness, to sustain the previous level of capability.

The increased readiness rate implies a need to decrease maintenance down time for unscheduled repairs. Repair time is decreased through the use of modular component design. Faults are traced to modules removable on the flightline, and the modules are removed and replaced.

These modules, and their associated reparable sub-units, represent one class of Air Force inventory items: recoverable or reparable spares. A major mission of the Air

Force Logistics Command (AFLC) is to manage reparable spares through a complex, multi-echelon inventory system.

Recoverable spares are typically items with very high unit costs and low unit demand rates (5:280). This combination of high cost and low demand precludes stocking reparable spares in depth at the base level. Units instead rely on base level repair, and an efficient AFLC parts pipeline, to meet demands for serviceable spares.

Recoverable spares are of two types: line replaceable units (LRUs), and shop replaceable units (SRUs). An LRU may contain one or more SRUs which are reparable at either the base or depot level. Failed LRUs removed from the end item are replaced with spares drawn from base supply. LRUs authorized to be repaired at base level are returned to supply when repair is complete, or when repair is unable to proceed due to a lack of parts to repair the LRU. Supply reports those LRUs authorized to be repaired locally, but not repaired because of insufficient SRUs, as "Awaiting Parts" (AWP)-- that is, the base is awaiting parts from the depot to repair the LRU.

The AFLC Monthly AWP Summary indicates that a relatively small number of LRUs account for the bulk of LRU AWP time at the base level. Warner Robins Air Logistics Center's November 1984 AWP Summary reported 774 end items in AWP status. Ten percent of the LRUs in AWP status accounted for sixty percent of the total AWP delays.

Justification

Justification for this research lies primarily in the need to manage an expensive spare parts pipeline more efficiently. Long periods of AWP for LRUs and SRUs at the base level indicate an already short supply of aircraft spares is being shortened further by our inability to keep the existing spares repaired. Analysis of the repair process in terms of base AWP sensitivity to depot repair cycle variables should identify the variables most critical in managing the pipeline flow.

A study currently being conducted by the Air Force Logistics Management Center (LMC) has indicated that little can be done at the base level to decrease AWP delays (12). A logical follow-on to the LMC study was to extend the repair cycle analysis to the depot level.

While Dyna-METRIC has been used to establish reparable inventory stockage levels and to determine end item readiness based on those levels, a sensitivity analysis has not been documented on how AWP is affected when the repair cycle variables are changed. Testing this aspect of the model provided secondary justification.

Specific Problem

Many depot repair process variables influence the length of time LRUs are in AWP status at base supply. How these variables affect the length of time LRUs are in AWP status needs to be clearly established to better manage LRU

availability. Presently, the length of time LRUs spend in AWP status is contributing to excessively long times between LRU failure and subsequent repair at the base.

Research Proposal

This research investigates the portion of the repair/resupply system which is external to the base, to determine the relationship between the variable components of the system and the resultant AWP time at the base. Knowing the sensitivity of AWP to these variables may enable managers to make more efficient use of the reparable assets now lying idle, awaiting parts.

Research Objectives

- 1) Examine the repair/resupply system to determine what the variables are, and the range over which they can be altered.
- 2) Determine if Dyna-METRIC can be used to measure the impact of variations in the values of these variables over that range to yield AWP days for selected LRUs.
- 3) Establish the relationship of the targeted variables to AWP days using Dyna-METRIC output and analytical methods.

Investigative Questions

- 1) What repair cycle variables, external to the base, most directly influence the total number of AWP days for a specified set of LRUs?

2) How would the number of AWP days for those LRUs be affected if values for those variables are changed?

3) What is the effect on the capability of the weapon system represented by those LRUs when the changes are made?

4) How useful is AWP as a capability indicator for that weapon system?

Scope and Limitations of Research

The reparable asset cycle is complex and varies somewhat with each asset, and among MAJCOMs for identical assets. To scale the problem into a workable size, only the top ten KC-135A LRUs (in terms of AWP delays) and their indentured SRUs will be analyzed.

Two flying hour scenarios will be modeled to evaluate mission capability under peacetime and wartime conditions for 365 day periods. Actual flying hour profiles and sortie turn rates for peacetime and surge exercise conditions were provided by SAC/LGL.

The feasibility of implementing actual changes is not a criterion of the study. The economic practicality and technical capability of actually producing the pipeline segment reductions modeled will not be addressed.

Limitations inherent to modeling in general, and those applicable specifically to Version 4 of Dyna-METRIC will be addressed in Chapter III.

II. Literature Review

Overview

This chapter provides a brief overview of the standard repairable item management process currently in use in AFLC, and a listing of terms and definitions key to its description. A review of existing analytical models is provided to give background to the evolution of the tools available to manage repairable inventories.

Terms and Definitions

The following terms are used in the description of the repairable item management process.

Repair Cycle - The collection of stages through which a repairable asset flows in the process of being returned to a serviceable condition. These stages include removal, awaiting shipment, in-transit, pre-repair screening/testing, repair actions, and return to serviceable stock (17:579).

Repairable or Recoverable Items - An item of a durable nature that can be economically returned to a serviceable condition either through field or depot repair (17:581).

End Item - An entity of hardware that is complete in itself, and not to be installed in another piece of equipment. An aircraft is one example of an end item (17:254).

Line Replaceable Unit (LRU) - An item that is normally removed and replaced as a single unit from an end item to

correct a maintenance discrepancy. An avionics "black box" is an example (17:393).

Shop Replaceable Unit (SRU) - A sub-unit of an LRU having a distinctive stock number for which spares are authorized to be maintained in base supply. These units are designed for later independent repair to allow fast turn-around repair of LRUs (17:627).

Recoverable Item Management

The management of recoverable spares represents a significant subset of AFLC's responsibility to provide supply, maintenance, and transportation support to the Air Force Major Commands, and other U.S. military agencies. In 1981, this category of items represented 170,000 line items valued in excess of \$10 Billion. These items are typically low demand, high cost items (5:280). The inventory/repair system can be viewed as a two-echelon system as depicted in Figure 1. The initial level of reparable spares is established during acquisition of a new system, with spares dispersed to the gaining units' organic supply facilities, and to a central depot supply location (5:281).

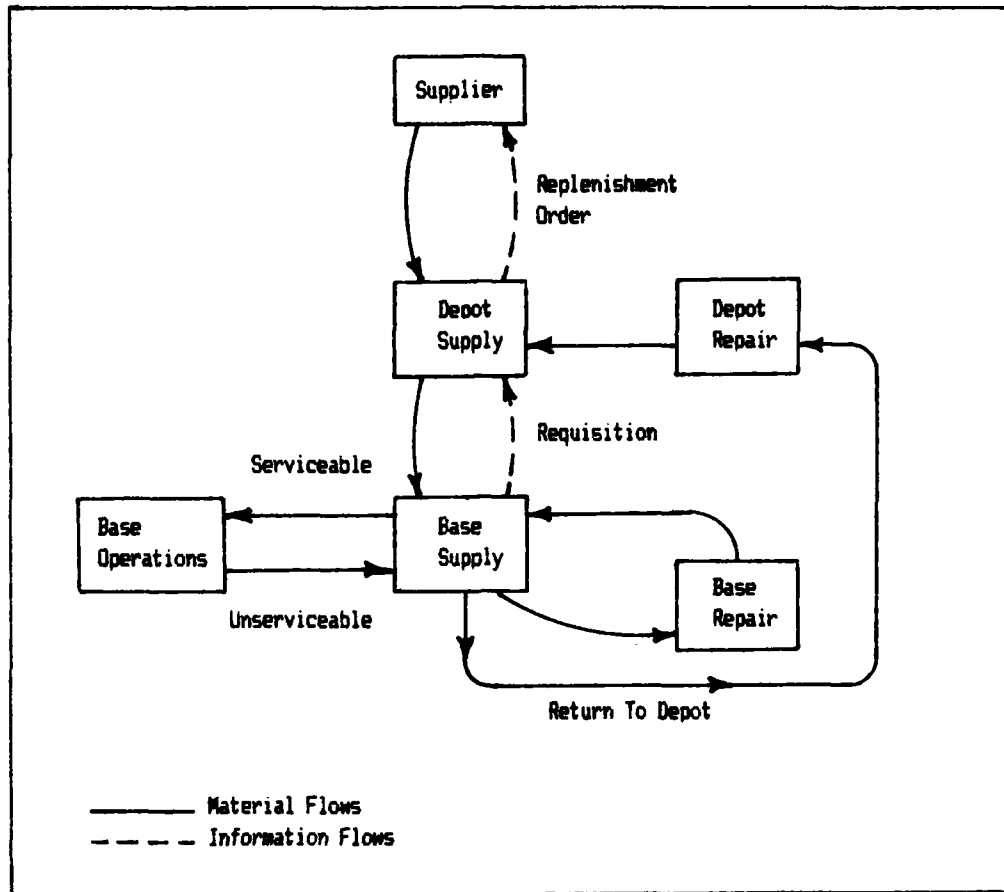

Figure 1. General Recoverable Item Flows (5:281)

The repair cycle normally begins with the removal of a repairable LRU from an aircraft or other major end item. A demand for a serviceable replacement is made at base supply. Where possible, the failed LRU then enters the base repair cycle, is restored to a serviceable condition, and returned to base supply stock to await the next cycle demand. LRUs and SRUs that require more specialized repair are forwarded to the second echelon with demand placed on depot supply for

a serviceable exchange. Not all reparable items fit neatly into this depot-base structure. Lateral resupply among bases within a Major Command, and vendor repair and resupply are common exceptions. The repair/resupply system for the majority of items, however, can be approximated by the two-echelon structure (5:281-282).

Repair Cycle Asset Control. The operational effectiveness of repair cycle item control, and support to maintenance, depends on the coordinated efforts of each organization.

Specific guidance for accountability and control of repair cycle assets is outlined in chapter 17 of AFM 67-1, Volume II, Parts 1 and 2. Base supply is accountable for all repair cycle items and must maintain strict management control over them throughout the repair process. The control (or audit trail) begins at supply when a customer requests a serviceable replacement for a potentially broken LRU. When the serviceable LRU is issued, it is given a supply document number, which serves as a common reference between supply and maintenance. While in the maintenance process, the reparable item is classified "Due-In-From-Maintenance" (DIFM) and its status is maintained in the base supply DIFM detail record. The audit trail ends when the reparable item is returned to supply in either a serviceable condition, or is returned still broken because it could not be repaired at the base level. When returned, the DIFM

detail record is annotated as repaired this station (RTS), not repaired this station (NRTS), or condemned (6:87).

A second demand can be placed on supply to support the repair process by a request for bit and piece parts to repair SRUs and LRUs. These are the smaller items replaced in the reparable asset to restore it to a servicable condition such as knobs, dials, diodes, and transistors. When repair is authorized at the unit level, and is unable to proceed due to stockout of these bit and piece parts, the asset is declared "Awaiting Parts" (AWP). The reparable item is stored in a secure area under Base Supply control until the bits and pieces are received, then returned to maintenance control for repair (6:87). Appendix C outlines the reporting process.

The AWP reporting system was designed to automatically link the base repair process with the next echelon (Depot Supply/Repair). The desired effect was to minimize transportation expense to second echelon repair facilities that are no better equipped than those existing at the base (6:89).

The bit and piece requisition generates a special requirements indicator code 'S' that causes a comparison of the requisition date and the estimated shipping date (ESD). Should the ESD exceed the requisition date by 45 days (60 days Overseas) the requirement for disposition reporting procedures applies. Non-expendable items require coordination with the End Article Item Manager (EAIM) prior

to shipment back to the depot. Expendable items will be handled as determined appropriate by Maintenance and Supply.

The disposition instructions from the item manager are transmitted by an XE8 response and incorporated in the AWP Validation listing (D-19 Report). The D-19 report summarizes AWP activity and provides current management information so that decisions can be made for processing requisitions, follow-up, or disposition actions.

Reparable Item Inventory Models

Effective management of reparable item inventories is essential to maximizing weapon system availability within fiscal constraints. Several inventory models have been developed to aid the logistics manager in controlling these inventories. A brief overview demonstrates the evolutionary nature of their development and provides background for the model selected for use in this research effort.

METRIC. To aid AFLC in managing its large inventory of reparable items, Craig Sherbrooke, a researcher with the Rand Corporation, developed a mathematical model called METRIC (Multi-Echelon Technique for Recoverable Item Control) in the late 1960's. The model is an extension of an earlier base stockage model, and simulates a two-echelon inventory system (base and depot) similar to that depicted in Figure 1. The model was designed to provide management a tool for optimizing new procurement, evaluating the existing distribution of stock, and redistributing system stock

between the bases and the depot (19:140). The objective of the model was to

determine the base and depot stock levels which minimize total expected base level backorders for a specific set of items and bases subject to an investment constraint (15:473).

The following assumptions are made in the model:

1. Demand follows a compound Poisson Probability distribution and is stationary over the prediction period.
2. There is no lateral resupply between bases.
3. All failed parts are repaired (no condemnations).
4. Failures among items are statistically independent.
5. Repair times are statistically independent.
6. Parts are immediately placed into repair as they enter the system, (no batch accumulation delays).
7. The level of repair depends solely upon the complexity of repair.
8. Items are normally considered to be equally essential among themselves and between bases (19:126-130).

Data requirements include:

1. System parameters (Variance to Mean Ratio of Demand, and optimization targets),
2. Item data (average repair time by item and base, unit cost, forecast and observed demand rates, item essentially), and
3. Base data (base percentage of repair, average

order and ship time, minimum atockage levels for each base, depot, and total system) (19:126-130).

Mod-METRIC. This model, created by Muckstadt, is an extension of the METRIC model pioneered by Sherbrooke. It permits modeling of a multi-item, multi-echelon, and multi-indenture inventory system which takes into consideration the hierarchy of parts in more complex reparable items. The objective of this model is to

minimize the expected base backorders for the end item subject to an investment constraint on the total dollars allocated to the end item and its components (15:475).

All assumptions applicable to the METRIC model apply to Mod-METRIC with the exception of item essentially. In the METRIC model an engine repair module backorder, and a backorder for an entire engine, are equally undesirable. Muckstadt suggests that this is unrealistic as an engine backorder would imply a grounded aircraft, while a backorder for a repair module may affect only one of several spare engines. Mod-METRIC considers the relationship between the engine repair module (SRU) and the end item (LRU) in computing the effectiveness of the resupply system. In identifying this relationship, Mod-METRIC is able to minimize backorders of LRUs by establishing optimal depot and base stockage levels of LRUs and SRUs within the total investment constraint (15:475).

Dyna-METRIC. The Dyna-METRIC model is the latest member of evolving pipeline models. The name METRIC was borrowed from Sherbrooke because the same elements and pipelines are modeled. The "Dyna" prefix denotes the replacement of METRIC and Mod-METRIC logic with dynamic programming. The model was developed to provide the logistician a tool to assess logistics support in a wartime environment.

Five new kinds of information were provided by the model:

1. Operational performance measures.
2. Effects of wartime dynamics.
3. Effects of repair capacity and priority repair.
4. Problem detection and diagnosis.
5. Assessments and requirements determination (12:1).

Dyna-METRIC allows analysis of either a two-echelon or three-echelon supply system under dynamic conditions. The three-echelon structure allows the introduction of a Consolidated Intermediate Repair Facility (CIRF) into the previous base-depot two-echelon system. More importantly, it measures logistics support in readiness and capability terms under a dynamic scenario, rather than peacetime steady state conditions.

The model is based on mathematical relationships explained by Hillestad and Carrillo in an Air Force sponsored Rand study (10:5). The Dyna-METRIC logic is based on a non-homogenous compound Poisson process, with the

systematically made against each scenario with one variable of the total depot repair cycle reduced in each run. The difference in base level AWP and the expected percent of NFMC aircraft was measured to evaluate the sensitivity of AWP, and weapon system capability to each of four depot pipeline segments.

Dyna-METRIC Overview

The Dyna-METRIC model is the result of research conducted by the Rand corporation as part of the Project AIR FORCE study "Strategies to Improve Sortie Production in a Dynamic Wartime Environment" (11:iv). It is the newest member of an evolving family of analytic inventory models for reparable item management. It can be used to assess supportability, or compute requirements. Results are based on the number of available aircraft and a given flying program.

Applications have included the initial study of C-141 engine spares requirements under surge conditions, readiness and supportability studies for various fighter aircraft, and an analysis of supply support for mobile tactical radar units (14). Dyna-METRIC is embedded in the experimental Combat Support Capability Management System being tested in the Pacific Air Force (PACAF) and is being used in the Sustainability Assessment Module of AFLC's Weapon System Management Information System to compute theater level assessments of major war plans (10:iv; 11:iv). Version 4.4

III. Methodology

Overview

This chapter provides a more detailed presentation of the DYNA-Metric model, outlines the structure of the research project, and explains how version 4.4 of Dyna-METRIC was used in the research experiment.

To achieve the research objectives, three intermediate requirements had to be met. First, the system being studied had to be clearly defined and limited to a workable size. For this project, the portion of the component repair/resupply system external to the base for KC-135A aircraft was analyzed.

Next, an analytical model had to be available that was capable of representing the system under dynamic conditions. Rand's Dyna-METRIC model was selected because it had this capability. The model was able to present output in terms of aircraft availability and to identify problem LRUs under changing conditions of demand. Version 4.4 was selected because of its increased capability of modeling depot characteristics.

Finally, an experimental design had to be constructed that would provide systematic analysis of the sensitivity of AWP time to the repair/resupply cycle variables. Two Dyna-METRIC runs were made initially, to establish baselines for both a peacetime and wartime scenario. Subsequent runs were

assumption of excess repair capacity and independence of the repair and demand processes. It states that

the mean number of items of any one type in resupply at time t is a function of all demands for that item and the capability to repair the items over the elapsed time period (4:15).

The ability to vary both the demand distribution and the service distribution enables the modeler to approximate the dynamics represented in a war-time environment.

Like Mod-METRIC, Dyna-METRIC considers the relationships between LRUs and SRUs in computing base stockage levels. The Dyna-METRIC model differs in that it optimizes only on the base level. A further explanation of Dyna-METRIC, focusing on Version 4.4 and its application in this research, is provided in Chapter III.

Summary

Reparable item inventories represent over 170,000 line items with a total value in excess of \$10 Billion. Their high cost per item coupled with a relatively low demand rate results in low item stockage levels.

Low stock levels make it necessary that the repair/resupply system be efficiently managed. Accountability for reparable items, as they flow through the base segments of the repair pipeline, is strictly maintained by procedures outlined in AFM 67-1 Volume II, parts 1 and 2.

Several pipeline inventory models have evolved to aid the inventory manager. The METRIC model was developed

the late 1960's. Its objective was to minimize base level backorders subject to an investment constraint. Mod-METRIC, though still an optimization model focusing on backorders, considered the relationship between SRUs and LRUs rather than assuming each to be equally essential. Both models minimize backorders under steady-state conditions.

Dyna-METRIC is the latest repairable inventory model to evolve. It recognizes the dynamic nature of wartime logistics and provides the analyst with information not available in previous models.

of Dyna-METRIC was used in this study as a tool to assess base AWP pipeline quantity shifts and weapon system capability changes under changing conditions of depot support.

Model Description. The Dyna-METRIC model is a mathematical representation of the reparable inventory logistics system. It views this system as a network of pipelines through which components flow as they are repaired or replaced (16:9). Figure 2 depicts a simplified view of an otherwise complex logistics process as modeled by Version 3.04.

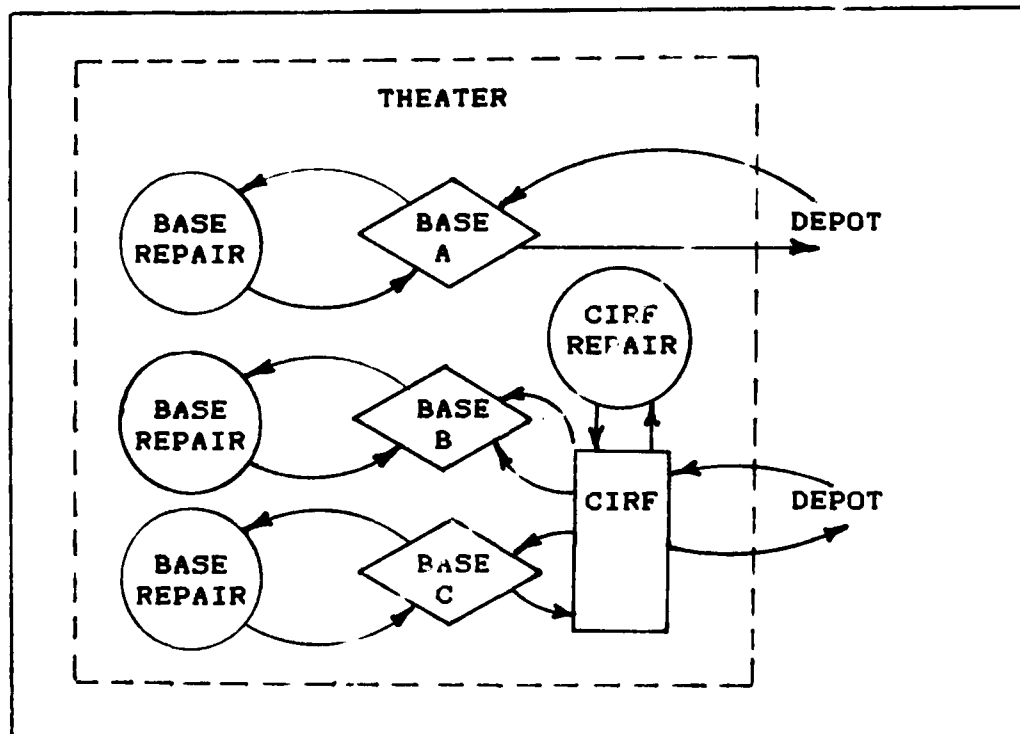

Figure 2. Dyna-METRIC View of the World (1:3).

The figure shows the focus of the model is on the repair facilities and the pipeline segments (depicted by arrows) connecting them. The view is limited to a single theater of operation, with the depot lying outside the system some known order and ship time away. With over 15,000 lines of FORTRAN code, Version 3.04 is not a simplistic model, but a detailed analytic representation of a complex system (9:22).

The level of detail describing the logistics system has increased with each Dyna-METRIC update. Version 4 gives the modeler a broader view of the repair cycle process than depicted in Figure 2. The system boundaries were expanded to include the depot repair process pipelines, thus enabling theater wide assessments which include depot support decisions.

Dyna-METRIC's key equation computes the expected quantity of components in each segment of the pipeline. For mathematical convenience a Poisson demand distribution, a random repair process with excess capacity, and independence between the repair and demand processes are assumed. When these assumptions are made, the expected number of each component type in the pipeline at time t is Poisson distributed with mean $\lambda(t)$. (fig. 3) (4:15).

$$\lambda(t) = \int_{s=0}^t d(s)F(t,s)ds$$

$F(t,s)$ = Probability that a service started at time s is not completed by time t .
 $d(s)$ = item repair demand rate at time s .

Figure 3. General Math Model (11:11)

The equation is a modification of Palm's theorem which allows calculation of the expected pipeline quantity under nonstationary conditions.

Model Assumptions and Limitations. Banks and Carson, in their simulation text, define a model as "a representation of a system for the purpose of studying the system" (3:9). The appropriate level of detail is determined by the project goals and must be consistent with the availability of data and other resources (2:61). For this analysis of the repair cycle process, it was neither feasible nor necessary to include every detail.

The Dyna-METRIC model provided a simplified representation of the repair/resupply process operating in a dynamic environment. Like most computer models, its logic was based on assumptions which were necessary for computational efficiency and for fulfilling the essential conditions of the model's underlying mathematics. Though less numerous

than in previous versions, Dyna-METRIC Version 4 had several assumptions and limitations. The actual number is dependent on the configuration or options used in the model. The options used in this project, and their meanings are presented in Table I.

TABLE I
Dyna-METRIC Options

Option Selected	Meaning
8	List Problem LRUs -- Up to 75 LRUs.
11	Calculate performance at 15 percent NFMC based on input or previous stock.
15	Generate Detailed Pipeline/Backorder File.
20	Only fly achievable PMC sorties -- Confidence to be achieved is 0.900, Scale unachievable sorties back to 90% of achievable level on each step.
23	Include in the Problem LRUs Report data about the status of the worst 10 SRUs per problem LRU.

Item demand was computed on the basis of achievable sorties rather than requested sorties by using option 20. All other assumptions and limitations of the basic model apply to this application. Assumptions and limitations are presented next as they applied to the model configuration used in this analysis.

1) Base repair is unconstrained. The base repair

process was assumed to be unconstrained in all model runs. This assumption and its resulting limitations were acceptable since the focus of the research was on AWP delays and weapon system capability shifts, not actual capability assessment.

Dyna-METRIC Version 4 allows the repair process to be constrained at all levels of repair using the test stand feature. Modeling this feature involves a considerable data collection effort, which in this case was not warranted. When actual capability measures are sought, and the repair process is known to deviate from the assumption of unconstrained repair, the test stand feature should be used. The performance of the logistics system may be either underestimated or overestimated when this assumption is incorrectly applied (12:15).

2) Aircraft are interchangeable at each base (16:35). By assuming all aircraft at a base are of one type, all components and sorties are assumed to be interchangeable. Obviously this is often not the case. A B-52 cannot bomb using KC-135A radar components, and a tanker can not be configured to complete a bomber mission profile. For model applications involving two or more distinct Mission Design Series (MDS) aircraft, the limitation is dealt with by splitting the single base into several bases -- one for each MDS. When a single MDS type aircraft is analyzed, as in this study, the assumption that all aircraft are interchangeable is valid, and no "workaround" was necessary.

3) Fully Mission Capable (FMC) sortie rates are independent of flightline resources and operational plans (16:33).

Dyna-METRIC assumes that an FMC aircraft will be able to complete a specified number of sorties per time period without regard to flightline resources. Although resources such as fuel trucks and load crews often impact the capability of the weapon system, they are not the focus of this logistics model. In cases where sortie turn rate is constrained by these resources, the actual capability forecast will be overstated. Flightline support was not a concern in this study, so the assumption was acceptable.

4) Cannibalization can be performed completely, instantly, and without consuming resources.

The model automatically juggles parts, concentrating broken components on the fewest number of aircraft (1:10). This juggling is performed through the cannibalization of serviceable components. All cannibalization actions are assumed successful and are performed independently of other repair actions.

Research Data Base

Although the intent of the research was not to assess the actual capability of a particular weapon system to achieve its requested flying program, the sensitivity analysis was not conducted under totally contrived conditions. Information for constructing two realistic

unclassified scenarios for this study was provided by HQ SAC/LGL. This information included the average number of sorties, sortie duration, and turn rate for a "typical" KC-135A squadron pursuing its normal peacetime proficiency flying program. Similar information was provided that represented an increased flying hour program similar to a wartime task force operation. Average 1984 peacetime usage rates for a CONUS KC-135A squadron possessing 15 aircraft were 5 to 7 sorties per day, each lasting 3.3 hours. The flying activity was typically spread across 7 or 8 of the 15 aircraft because of alert commitment, TDY tasking, or prolonged maintenance. A flying program consisting of 15 aircraft flying 1.0 sortie per day of 3.3 hours duration was used in the peacetime scenario.

Grissom AFB was selected as the peacetime operating location to be modeled for two reasons. The base has two KC-135A squadrons each generating demand across approximately 15 aircraft. The 29 KC-135A aircraft at Grissom represented 75% of the total C-135 MDS aircraft supported by base supply. Secondly, no other aircraft using the selected LRUs/SRUs were supported by Grissom, which simplified the reduction of base Peacetime Operating Stock (POS) to fit the scenario.

Usage rates for the wartime scenario were provided by SAC/LGL from a surge test conducted in 1977 at McConnell AFB. In the McConnell test, KC-135As flew 2.0 sorties per day at 3.0 hours per sortie. This flying program was used

for 15 aircraft operating out of Mildenhall RAF, UK for the Dyna-METRIC wartime scenario. All POS and WRM assets in base supply were assumed available to support the 15 aircraft.

Data Collection/Preparation

The purpose of this research was to determine the impact of varying the depot repair cycle on base AWP delays for selected LRUs. Data collection and preparation constituted a major portion of the research effort. The following section outlines the data sources used and the preparation of data from those sources.

A list of twenty KC-135A LRUs experiencing the greatest AWP delays at the base level in 1984 was obtained from HQ SAC/LGL (Appendix B). This data was compiled from Andersen AFB, Guam and CONUS SAC units reporting through the Standard Base Supply System.

LRUs having no indentured SRUs, such as the periscopic sextant, were determined to have been AWP for causes external to the depot repair cycle and were thus eliminated from the list. Of the remaining fifteen LRUs, four were eliminated because their indentured SRUs supported a large number of aircraft types, which complicated the scaling of resources.

Wartime depot repair limits for the final list of 11 LRUs and 47 SRUs were provided by AFLC/MAWR. The component list was then compared to KC-135A WRSK Kit listings to

determine which LRUs had D029 demand data. Of the 58 components modeled, only 6 LRUs and 1 SRU were included in WRSK, and thus had D029 data available.

Comparison of component demands per flying hour between AFLC's Recoverable Consumption Item Requirement System (D041) and D029 data bases, however, indicated that D029 demand data was often adjusted to a different value than the worldwide average computed by D041. In one instance, the D029 demands per flying hour for an LRU was less than the D041 demand for one of its indentured SRUs. This implies that the SRU and its parent LRU had independent failure rates. To avoid inconsistencies between data bases, no D029 values were used.

Values for Demands per Flying Hour, Depot Shop Flow days, Reparable Intransit Days to depot, base NRTS rates and production lead times for each item were extracted from D041. Actual and authorized POS and WRM levels for Grissom AFB and Mildenhall RAF were extracted from the Logistics Management Data Bank using the Supportability Analysis Forecasting and Evaluation Model (Project SAFE). A source summary for each input variable is listed in Appendix F.

Data Assumptions

1) Input data for this experiment were assumed to represent actual values for KC-135A aircraft. D041 data represents world wide average usage of the modeled reparables. While none of the LRUs examined were KC-135A

unique, many were used only by C-135 MDS aircraft. Usage of SRUs was more diverse, with some items common to all C-135s, C-130s, and B-52s. Since an actual KC-135A capability assessment was not the focus of this research, this assumption did not degrade the usefulness of the output.

2) Depot support priority was assumed equal among all MDS aircraft. The KC-135A fraction of the total depot support for shared items was approximated by the ratio of KC-135As to the total number of aircraft supported for that item (QPA for each MDS considered).

Depot repair facilities commonly repair items grouped by similar technology, rather than by weapon system or specific stock number. To scale the depot to a size where demand generated by 15 aircraft would be significant, the depot daily repair limit and depot stock were decreased from their actual values to a representative fractional value. The portion of the total depot support that was dedicated to 15 KC-135As was assumed to be given by:

$$\text{Depot Fraction} = \frac{(\text{KC135A QPA}) \times 15}{(\text{MDS QPA}) \times \#\text{Aircraft per MDS}}$$

for all applicable MDS aircraft using that item.

For components used solely by the 471 KC-135As, reducing the depot stock and repair capacity to 15/471 of its total, would represent the support proportionate to the 15 aircraft scenario. Scaling the depot stock and repair

capacity in this manner implies equal priority among all aircraft when one or several MDS aircraft use the part.

The validity of the assumption is dependent on the scenario being modeled. Assets common to two or more weapon systems, such as a radar indicator or TACAN receiver, may be reallocated from one MDS to another based on the priority of each system in the scenario. AWP time would be impacted according to priority of that base's aircraft. For this research, only KC-135As were modeled, so changes in AWP delays were attributable only to reductions in the depot pipeline. No change due to loss or increase in depot support priority was observed.

Similarly, base supply assets that were shared by EC-135 aircraft at the peacetime base were reduced by 25%. This left 75% of Grissom's POS to support the KC-135A flying program.

Scenario

Two baseline Dyna-METRIC runs were initially conducted using the unclassified scenario information provided by SAC/LGL. The peacetime scenario parallels the activity of a KC-135A Squadron composed of 15 aircraft, operating from peacetime operating stock, engaged in a proficiency flying program. The repair/resupply process was depicted in Chapter II. The base has Remove, Repair, and Replace (RRR) capability and is serviced by a depot. The wartime scenario

parallels a Tanker Task Force operation where flying activity is conducted from an established location, with KC-135A support in place using both POS and WRM stock.

Repair Process Variables

Figure 4 illustrates the portion of the reparable component repair/resupply system external to the base that was analyzed.

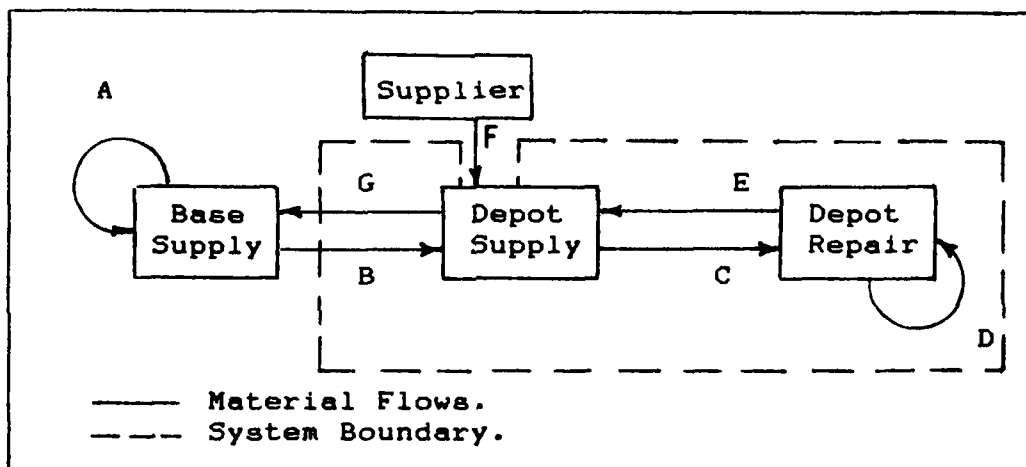

Figure 4. System Variables Subjected to Analysis.

AFLCR 57-4 defines the depot repair cycle as the timespan, in days, from the time an unservicable item is removed from use until the time it is made serviceable in depot maintenance and ready for return to use. DO41 tracks five components of the repair cycle: 1) Base Processing Days [A], 2) Reparable Intransit Days [B], 3) Supply to Maintenance Days [C], 4) Shop Flow Days [D], and 5) Serviceable

Turn-in Days [E]. Base Processing Days and Procurement Leadtime [F] lie outside the modeled system boundary, and were not analyzed.

Experimental Design

The purpose of the experimental design is twofold: 1) to provide a structure for the investigative process and 2) to reduce the number of trials required to produce the information needed.

The experimental design selects a particular approach for gathering original information that will provide enough knowledge about the phenomenon or system to allow valid inferences to be drawn about its behavior (18:30).

Two output measures were recorded for answering the research questions presented in Chapter I: the base AWP pipeline quantity and the expected percent of NFMC aircraft. Research question 1 asked which repair cycle variables external to the base, most directly influence the total number of AWP days for a specified set of LRUs. Figure 4 showed five components of the Depot Repair Cycle that were tracked by the D041 data base. Repairable Intransit Time, Supply to Maintenance Days, Depot Shop Flow and Serviceable Turn-In Days all lie beyond the base's span of control. To answer which of these components had the greatest AWP impact for the set of LRUs, the base AWP pipeline value was evaluated over the series of runs. The variable that provided the greatest AWP reduction for a specified percentage variable decrease, has the greatest impact.

Figure 5 shows how the AWP output will be presented. Base AWP quantities that result from reductions of each D041 Depot Repair Cycle variable will be displayed. Results from both scenarios are shown together for each variable evaluated. This was done to assess any AWP impact dependency on attributes of the scenario such as increased demand or differing stock quantities.

TABLE II							
Sample of Variable Impact on AWP Quantity							
Day	Base-line	.25< DSF	△ AWP (%)	.50< DSF	△ AWP (%)	.75< DSF	△ AWP (%)
1	x.x	x.x	.xx	x.x	.xx	x.x	.xx
15	x.x	x.x	.xx	x.x	.xx	x.x	.xx
.	x.x	x.x	.xx	x.x	.xx	x.x	.xx
.	x.x	x.x	.xx	x.x	.xx	x.x	.xx
330	x.x	x.x	.xx	x.x	.xx	x.x	.xx
365	x.x	x.x	.xx	x.x	.xx	x.x	.xx

Figure 5. Aggregate AWP Results (sample)

A second table illustrates how impact varies between individual LRUs. (Figure 6).

These tables will be used to answer the second research question addressing how the number of AWP days for the set of LRUs modeled would be affected as values for the depot pipeline segments were changed.

TABLE III							
DSF Reduction Impact on Individual LRUs							
LRU	Base- line	.25< DSF	AWP (%)	.50< DSF	AWP (%)	.75< DSF	AWP (%)
1	.xx	.xx	x.x%	.xx	x.x%	.xx	x.x%
2	.xx	.xx	x.x%	.xx	x.x%	.xx	x.x%
.	.xx	.xx	x.x%	.xx	x.x%	.xx	x.x%
.	.xx	.xx	x.x%	.xx	x.x%	.xx	x.x%
11	.xx	.xx	x.x%	.xx	x.x%	.xx	x.x%

Figure 6. Variable Impact on Individual LRUs (sample)

The Dyna-METRIC performance measure "Expected Percent NFMC Aircraft" will be used to answer the third research question. This question asks how reductions in pipeline segments will affect weapon system capability.

The Expected NFMC Percent that results from each run will be displayed in tabular form as shown in Figure 7.

Question 4 will be answered using the problem parts listing for the baseline run. It will be determined from the listing if AWP is a reliable indicator of weapon system capability. AWP values for problem parts that are listed as impacting system capability will be compared to AWP values of other LRUs to determine if there is a direct cause-effect relationship.

TABLE IV					
Expected Rates: % NFMC Aircraft					
Var.	Decr. (%)	---Peacetime---		---Wartime---	
		NFMC	Decr. (%)	NFMC	Decr. (%)
DSF	.25	.xxx	.xxx	.xxx	.xxx
"	.50	.xxx	.xxx	.xxx	.xxx
"	.75	.xxx	.xxx	.xxx	.xxx
RIT	.25	.xxx	.xxx	.xxx	.xxx
"	.50	.xxx	.xxx	.xxx	.xxx
"	.75	.xxx	.xxx	.xxx	.xxx
SMX	.25	.xxx	.xxx	.xxx	.xxx
"	.50	.xxx	.xxx	.xxx	.xxx
"	.75	.xxx	.xxx	.xxx	.xxx
TRN	.25	.xxx	.xxx	.xxx	.xxx
"	.50	.xxx	.xxx	.xxx	.xxx
"	.75	.xxx	.xxx	.xxx	.xxx

Figure 7. Variable Impact on Capability (sample)

Procedure

The impact of depot repair cycle variables on base level AWP and weapon system capability was measured by first making a baseline run for each scenario. Additional model runs were then made with 25%, 50%, and 75% reductions in Repairable Intransit Days (RIT), Supply to Maintenance Days (SMX), Depot Shop Flow Days (DSF), and Serviceable Turn-in Days (TRN). One variable was reduced in each run, making a total of 12 additional runs for each scenario. The results were recorded as previously discussed, and are displayed with analysis in Chapter IV.

Methodology Limitations

Only reductions in depot pipeline values were evaluated. The effect of decreasing depot support, while achievable in an identical manner, was not considered within the scope of the research. This research sought only to identify areas of greatest impact for improvement, not for least impact of reducing capability.

Values for transportation time to the depot and depot administrative delay were not input into the model in the usual manner. These delays were captured on an item-by-item basis and included in the model input value "Depot Repair Time". By combining three Dyna-METRIC pipeline segments (Depot Administrative Delay, Retrograde Time, and Depot Repair Time) into one segment, it was possible to model item specific rather than average delays. It also caused the pipeline values for the three delays to be rolled up into the depot repair segment report value. Additional accuracy was gained by modeling actual rather than average delays. The detailed pipeline segment report values for depot administrative delays and the retrograde pipeline, however, were lost.

IV. RESULTS

Overview

This chapter presents the modifications that were made to the research methodology, and the results obtained from the research experiment.

The results of the Dyna-METRIC model runs outlined in Chapter III are presented in tabular form for each altered variable. The aggregate number of LRUs Awaiting Parts (AWP) at the base, and Not Fully Mission Capable (NFMC) percentages are displayed for each day of analysis. The purpose of the tables is to display the shifts in total AWP quantities across all LRUs which resulted from reductions in selected depot repair cycle components. Results from both the peacetime and wartime model runs are displayed together to contrast the amount of AWP shift between scenarios. A second table displays the shift in AWP quantities for each LRU on a selected day of analysis. The purpose of this table is to display how the effect of a pipeline segment reduction varies among the individual LRUs. Together, the tables are used to answer investigative questions 2, 3, and 4.

The results of the Dyna-METRIC runs are presented, followed by an explanation of their significance in answering the research questions. The chapter concludes with a summary of the results upon which the conclusions and recommendations found in Chapter V are based.

Interpretation of Output

Several performance measures are provided by Dyna-METRIC for each day of analysis. These measures include the probability of achieving a target NFMC rate, the probability of achieving a target sortie rate, the expected number of FMC aircraft at a specified degree of confidence, the expected number of NFMC aircraft, the expected percent of aircraft that were NFMC, and the expected number of sorties that were flown. These values are computed at the end of each day of analysis for both full and partial cannibalization policies. (Since cannibalization was allowed on all parts, the values under both policies are identical.) The value "Expected % NFMC" will be the only performance value displayed in the tables. It provides a measure that can be used for comparison between the two scenarios that is independent of their unequal sortie achievement goals.

The Dyna-METRIC Detailed Pipeline Segment Report displays each LRU and SRU's pipeline contents at the end of the day of analysis. Pipeline segments that are represented in the report include the retrograde, administrative, in test/repair, on order, and Awaiting Parts pipelines. Values are displayed for each base and depot. Although each pipeline segment value aids in diagnosing the cause of capability shortfalls, the base AWP pipeline segment is the only segment value presented in this research. This pipeline model segment represents the expected number of

LRUs that are delayed in base repair awaiting SRUs. Effects on this variable brought about by decreasing depot pipeline values was the focus of the experiment.

Methodology Modifications

Initial model runs with the Depot Repair Limit scaled as outlined in Chapter III yielded no change in AWP quantities as depot repair cycle variables were altered. Analysis of the depot in-test/repair pipeline showed that some components were waiting in an ever-increasing queue. Reducing the depot shop flow time caused no AWP reduction for those LRUs, because the Depot Repair Limit was so constraining that changes in other variables caused no changes in output. Subsequent runs were made with the Depot Repair Limit increased. Only with this constraint relaxed (i.e., increased) could the cause and effect relationship between pipeline segment reductions and AWP delays at the base be observed. To allow these observations to be made, all model runs were later made with this constraint removed.

Allowing depot repair to be modeled as unconstrained can overstate actual weapon system capability. As the purpose of the research was a demonstration of AWP sensitivity to depot repair variables, not the actual assessment of weapon system capability, this additional departure from real-world conditions did not seriously degrade the usefulness of the research. It does, however, limit the applicability of the findings.

A second modification in the methodology was necessary to achieve useful results. The use of Option 20 as outlined in Chapter III presented an unforeseen complication in comparing shifts in total AWP quantities from the wartime baseline to subsequent model runs. Option 20 was used because it computes demand for problem parts on the basis of achievable sorties rather than requested sorties. LRUs that have failed and are undergoing repair do not continue to generate additional demands.

The wartime baseline run identified L-1, L-2, and L-6 as unable to meet the requested 2.0 sortie rate and automatically reduced their goal to 1.8 sorties per day. All pipeline quantities, including base AWP, were computed using a 1.8 sortie rate for those three LRUs and their indented SRUs. The remaining components used the requested 2.0 rate for pipeline calculations. Reducing the values of input variables such as Depot Shop Flow Days (DSF) and Repairable Intransit Time (RIT) allowed L-6 to fully meet the target sortie rate and participate in more sorties on subsequent runs.

By flying in more sorties, L-6 generated more failures for itself and its SRUs, which resulted in larger pipeline values than the baseline run. Pipeline value comparisons against the baseline were not valid for that component since more AWP days were generated. As a solution, LRU #6 (L-6) AWP days were excluded from all aggregate AWP totals to

allow comparison of AWP values produced by a constant sortie rate across the remaining LRUs.

Performance measures such as "Expected * NFMC" are based solely on the achievable FMC sortie rate. The comparison of performance measures between model runs having different LRU scaling remains valid.

Presentation and Analysis of Research Question 1

The first objective of this research project was to identify the repair cycle variables, external to the base, that most directly influenced the total number of base AWP days for a specified set of LRUs. The question was approached in two steps. Step 1 involved identifying the sectors of the total repair cycle pipeline that were external to the base. Chapter III presented those segments.

Step 2 involved establishing realistic baseline values for each pipeline segment for the modeled LRUs and SRUs. These values, though not KC-135A unique, were representative of the aggregate repair flow of which the KC-135A components were a part. The refueling boom (L-1), for example, is an LRU on 4 KC-135 models, 4 EC-135 models, and 2 NKC-135 model aircraft. The same depot repair process supports all models, including the KC-135A; however, this research was concerned only with the impact on the KC-135A. As discussed in Chapter III, baseline data for Repairable Intransit Days, Supply to Maintenance Days (SMX), Depot Shop Flow, and

Serviceable Turn-in Days (TRN) were all obtained from AFLC's D041 data base.

The degree to which each of these pipeline segments affected the base AWP delays was related directly to the the second research question: How would the number of AWP days for those LRUs be affected as values for these variables changed?

Presentation and Analysis of Research Question 2

Although Dyna-METRIC has been capable of modeling multiple levels of indenture since its initial release, research failed to reveal an analysis where this feature has been used. Face validity for this feature was accomplished by conducting two model runs. An initial baseline run verified that version 4.4 would accept and provide analysis for indentured SRUs. A second run, with repair cycle times reduced, indicated that a decrease in depot pipeline segments caused reduced pipeline quantities in the base AWP pipeline.

No attempt was made to draw parallels from actual 1984 AWP totals for the 11 LRUs to the model results. To verify the model in this manner would require the entire KC-135A fleet be modeled, using historical data from each parent base, and accurate proportioning of depot resources for common use LRUs and SRUs. This type of verification effort was not feasible within the scope of the research. It is

upon this acceptance of face validity that the following results are presented.

AWP delays at the base reflect inadequate stock of SRUs and "Bit and Piece" parts to support the base repair process. As the SRU pipeline time from depot to base was shortened, AWP delays for the LRU were expected to decrease. Reductions in base AWP which would result from decreases in each segment of the depot repair process pipeline were first approximated.

Mean values from pipeline segments listed in Appendix G (RIT, SMX, DSF and TRN) were added to the average deterministic depot-to-base transportation time and average base repair cycle time, which yielded an expected mean total pipeline length of 51.5 days for the SRUs (Figure 8). This assumes that the expected SRU pipeline time equals the base LRU AWP time. The relative length of each depot segment to the total pipeline length was calculated to judge model output. Results of reducing each depot pipeline segment are presented first for each variable as an approximate expected value, then as they were calculated by the Dyna-METRIC model.

$$E(\text{Total Mean SRU Pipeline Days}) = \text{Mean Test Time} + \text{Base Admin. Delay} + \text{Mean RIT} + \text{Mean SMX} + \text{Mean DSF} + \text{Mean TRN} + \text{Avg. Depot-Base Trans.}$$

Figure 8. Computation of the Expected Total Pipeline Length.

Depot Shop Flow. The Depot Shop Flow segment represented 18% of the total repair cycle pipeline. Reductions of 25%, 50%, and 75% were anticipated to cause a decrease in base AWP days of approximately 4.5%, 9%, and 13.5%, assuming that the expected SRU pipeline was equal to the total LRU AWP days. With base repair present, as in both modeled scenarios, fewer components flow through the depot, reducing the benefit of decreased Depot Shop Flow days. The total number of LRUs calculated by Dyna-METRIC to be in the base AWP pipeline segment for the baseline, and subsequent runs with reduced Depot Shop Flow days, are presented in Table II. The table presents the baseline model AWP values for peacetime and wartime scenarios, with 25%, 50%, and 75% reductions in Depot Shop Flow Days.

TABLE II

Depot Shop Flow Impact

Peacetime Aggregates (LRUs)							
Day	Base- line	.25< DSF	△ AWP (%)	.50< DSF	△ AWP (%)	.75< DSF	△ AWP (%)
1	11.08	10.46	.056	10.28	.072	9.3	.161
15	7.93	7.57	.045	7.4	.067	6.96	.122
30	7.19	6.93	.036	6.76	.060	6.54	.090
90	6.96	6.75	.030	6.59	.053	6.43	.076
150	6.96	6.75	.030	6.59	.053	6.43	.076
210	6.96	6.75	.030	6.59	.053	6.43	.076
270	6.96	6.75	.030	6.59	.053	6.43	.076
300	6.96	6.75	.030	6.59	.053	6.43	.076
330	6.96	6.75	.030	6.59	.053	6.43	.076
365	6.95	6.75	.030	6.59	.053	6.43	.076
Wartime Aggregates							
1	13.48	13.34	.010	13.01	.035	12.79	.051
15	12.58	12.35	.018	12.14	.035	11.93	.052
30	12.32	12.09	.019	11.89	.035	11.69	.051
90	12.23	12.00	.018	11.80	.035	11.60	.052
150	12.23	12.00	.018	11.79	.036	11.60	.052
210	12.23	12.00	.018	11.79	.036	11.60	.052
270	12.23	12.00	.018	11.79	.036	11.60	.052
300	12.23	12.00	.018	11.79	.036	11.60	.052
365	12.23	12.00	.018	11.79	.036	11.60	.052

Across the 11 LRUs, a 25% DSF reduction causes AWP delays to decrease by an average of 3% for the peacetime scenario and 2% in wartime. Decreases of 50% and 75% are shown to produce an average 5% and 8% reduction in AWP delays in the peacetime scenario and 3 1/2% and 5% reductions in wartime.

Output results listed in Appendix J show that AWP delays are unchanging for all days of analysis following the 150th day of each scenario. Table III was constructed using these constant values to illustrate the effects of pipeline reductions on individual LRUs after day 150.

TABLE III
DSF Reduction Impact on Individual LRUs

LRU	Base-line	.25% DSF	Δ AWP (%)	.50% DSF	Δ AWP (%)	.75% DSF	Δ AWP (%)
1	.84	.78	7.0%	.72	14.0%	.70	17.0%
2	.13	.09	--	.09	--	.07	--
3	1.22	1.22	--	1.22	--	1.22	--
4	1.56	1.54	1.3%	1.52	2.5%	1.50	3.8%
5	.07	.07	--	.07	--	.07	--
6	1.24	1.21	2.4%	1.17	5.6%	1.13	8.9%
7	.66	.64	3.0%	.61	7.6%	.58	2.0%
8	.38	.37	2.6%	.37	2.6%	.36	5.3%
9	.08	.08	--	.08	--	.08	--
10	.73	.71	2.7%	.70	4.1%	.68	6.8%
11	.05	.04	--	.04	--	.04	--

The effect of the reduction in shop flow days ranges from no impact for LRUs 3, 5, 9, and 11 to a decrease of approximately 6% for each 25% reduction in DSF for LRU 1. From the two tables, it appears that the amount of AWP impact resulting from a pipeline reduction is unique to each individual LRU and varies between the scenarios modeled.

Next, the effects of reducing Repairable Intransit Days were evaluated.

Repairable Intransit Days. Appendix G lists the baseline RIT values for individual components. The values range from 6 to 24 days with a mean of 11.9 days. This represents approximately 23% of the expected total mean pipeline discussed previously. Reduction of RIT by 25%, 50%, and 75% causes an expected total AWP reduction of approximately 5.8%, 11.9%, and 17.0%. The actual AWP reductions that resulted from decreasing the RIT pipeline segment are illustrated in Table IV.

Actual AWP reductions resulting from a 25% decrease in Repairable Intransit Days were approximately 4% for the peacetime scenario and 3% for the wartime scenario. Reducing RIT 50% and 75% caused the aggregate AWP delay to be reduced by approximately 8% and 11% in peacetime and 6% and 9% in the wartime scenario. (Table IV)

TABLE IV

Reparable Intransit Days Impact

Peacetime Aggregates (LRUs)							
Day	Base- line	.25< RIT	△ AWP (%)	.50< RIT	△ AWP (%)	.75< RIT	△ AWP (%)
1	11.08	10.61	.042	10.11	.088	9.63	.131
15	7.93	7.59	.043	7.32	.077	6.90	.130
30	7.19	6.91	.039	6.60	.082	6.34	.118
90	6.96	6.70	.037	6.43	.076	6.20	.109
150	6.96	6.70	.037	6.43	.076	6.20	.109
210	6.96	6.70	.037	6.43	.076	6.20	.109
270	6.96	6.70	.037	6.43	.076	6.20	.109
300	6.96	6.70	.037	6.43	.076	6.20	.109
330	6.96	6.70	.037	6.43	.076	6.20	.109
365	6.96	6.70	.037	6.43	.076	6.43	.109
Wartime Aggregates							
1	13.48	13.08	.030	12.66	.061	12.26	.090
15	12.58	12.21	.029	11.82	.060	11.45	.090
30	12.32	11.95	.030	11.58	.060	11.21	.090
90	12.23	11.86	.030	11.49	.060	11.16	.087
150	12.23	11.86	.030	11.49	.060	11.13	.089
210	12.23	11.86	.030	11.49	.060	11.13	.089
270	12.23	11.86	.030	11.49	.060	11.13	.089
300	12.23	11.86	.030	11.49	.060	11.13	.089
365	12.23	11.86	.030	11.49	.060	11.13	.089

Supply to Maintenance Days. The third pipeline segment analyzed was Supply to Maintenance Days. The 10 day SMX value listed in Appendix G is the D041 standard delay for depot repaired items. Zero delay is the standard value for items which are contractor repaired. Fifty-four of the fifty-eight items were depot repaired, yielding a mean SMX pipeline segment length of 9.3 days. This segment represents 15% of the expected total mean pipeline length. Reductions of SMX by 25%, 50%, and 75% causes an expected total pipeline reduction of 3.8%, 7.5%, and 11.3%. Actual AWP reductions resulting from decreases in Supply to Maintenance Days are presented in Table V.

Actual AWP reductions resulting from a 25% decrease in SMX were approximately 2.9% for the peacetime scenario and 2.5% for the wartime scenario. Reducing SMX 50% and 75% caused the aggregate AWP delays to be reduced by approximately 5.6% and 9.2% in peacetime and 4.8% and 7.4% in wartime. (Table V).

TABLE V

Supply to Maintenance Days Impact

Peacetime Aggregates (LRUs)							
Day	Base-line	.25< SMX	△ AWP (%)	.50< SMX	△ AWP (%)	.75< SMX	△ AWP (%)
1	11.08	10.87	.019	10.66	.038	10.40	.062
15	7.93	7.73	.025	7.53	.050	7.29	.081
30	7.19	6.99	.028	6.80	.054	6.55	.089
90	6.96	6.76	.029	6.57	.056	6.32	.092
150	6.96	6.76	.029	6.57	.056	6.32	.092
210	6.96	6.76	.029	6.57	.056	6.32	.092
270	6.96	6.76	.029	6.57	.056	6.32	.092
300	6.96	6.76	.029	6.57	.056	6.32	.092
330	6.96	6.76	.029	6.57	.056	6.32	.092
365	6.96	6.76	.029	6.57	.056	6.32	.092
Wartime Aggregates							
1	13.48	13.17	.023	12.84	.047	12.59	.066
15	12.58	12.28	.024	11.98	.048	11.65	.074
30	12.32	11.73	.024	11.73	.048	11.41	.074
90	12.23	11.93	.025	11.64	.048	11.32	.074
150	12.23	11.93	.025	11.64	.048	11.32	.074
210	12.23	11.93	.025	11.64	.048	11.32	.074
270	12.23	11.93	.025	11.64	.048	11.32	.074
300	12.23	11.93	.025	11.64	.048	11.32	.074
365	12.23	11.93	.025	11.64	.048	11.32	.074

Serviceable Turn-in Days. Serviceable Turn-in Days was the final depot repair cycle segment evaluated. This segment represents the length of time needed to process serviceable items from depot repair to depot supply. With a mean value of of 2.89 days, it was the shortest pipeline segment, representing less than 5% of the total mean pipeline. Reductions of 25%, 50%, and 75% were anticipated to yield no greater total AWP reductions than 1.3%, 2.5%, and 3.8%. Actual impact presented in Table VI shows that the shift in AWP days resulting from TRN reduction was minimal at all levels of reduction after day 30.

TABLE VI

Serviceable Turn-in Days Impact

Peacetime Aggregates (LRUs)							
Day	Base- line	.25< TRN	△ AWP (%)	.50< TRN	△ AWP (%)	.75< TRN	△ AWP (%)
1	11.08	10.82	.023	10.77	.028	10.55	.048
15	7.93	7.79	.018	7.85	.010	7.65	.035
30	7.19	7.11	.011	7.06	.018	7.01	.025
90	6.96	6.90	.009	6.85	.016	6.84	.017
150	6.96	6.90	.009	6.85	.016	6.84	.017
210	6.96	6.90	.009	6.85	.016	6.84	.017
270	6.96	6.90	.009	6.85	.016	6.84	.017
300	6.96	6.90	.009	6.85	.016	6.84	.017
330	6.96	6.90	.009	6.85	.016	6.84	.017
365	6.96	6.90	.009	6.85	.016	6.84	.017
Wartime Aggregates							
1	13.48	13.42	.004	13.36	.009	13.30	.013
15	12.58	12.53	.004	12.47	.009	12.41	.013
30	12.32	12.27	.004	12.21	.009	12.15	.014
90	12.23	12.17	.005	12.17	.005	12.06	.014
150	12.23	12.17	.005	12.17	.005	12.05	.015
210	12.23	12.17	.005	12.17	.005	12.05	.015
270	12.23	12.17	.005	12.17	.005	12.05	.015
300	12.23	12.17	.005	12.17	.005	12.05	.015
365	12.23	12.17	.005	12.17	.005	12.05	.015

Presentation and Analysis of Research Question 3

Research question 3 addresses the effect these depot repair cycle reductions would have on actual weapon system capability.

The Dyna-METRIC output value "Expected % NFMC Aircraft" was used as the capability measure for assessing this aspect of the research. It allowed comparison of impact between the two scenarios even though they differed in sortie achievement goals.

From the sensitivity analysis results listed in Appendix J, it appears that AWP pipeline values and performance measures reach a level at day 150 that remains constant throughout all subsequent days of analysis. The results of the 12 model runs for a common day of analysis (Day 150 and beyond) are presented in Table VII.

The largest shifts in % NFMC aircraft occur in the wartime scenario. A 50% decrease in Depot Shop Flow results in a 2.5% decrease in NFMC aircraft in the peace scenario and a 4.2% decrease during wartime.

Not surprisingly, the largest peacetime NFMC shift results from reductions in RIT, the largest average pipeline segment. Referring to the 75% reduction results for the peacetime scenario, reduction in Repairable In-Transit time results in a 3.9% NFMC decrease, while reducing DSF and SMX by the same percentage yields a 3.5% decrease. These reductions appear consistent with their relative pipeline

segment lengths. The RIT segment represents 23% of the total mean pipeline, while DSF and SMX each represent 15%.

TABLE VII

Expected Rates: % NFMC Aircraft

Var.	Decr. (%)	--Peacetime--		---Wartime---	
		NFMC	Decr. (%)	NFMC	Decr. (%)
DSF	.25	.199	.015	.172	.017
"	.50	.197	.025	.168	.042
"	.75	.195	.035	.165	.057
RIT	.25	.199	.015	.172	.017
"	.50	.196	.030	.169	.034
"	.75	.194	.039	.166	.051
SMX	.25	.200	.010	.172	.017
"	.50	.198	.020	.170	.039
"	.75	.195	.034	.167	.046
TRN	.25	.201	.005	.175	0
"	.50	.201	.005	.174	.006
"	.75	.200	.010	.174	.006

Baseline (Scenario 1) = .202 NFMC

Baseline (Scenario 2) = .175 NFMC

When system performance is not influenced significantly by a limited number of critical parts, pipeline reductions in the largest average pipeline segment yields the greatest performance improvement.

The impact of individual LRUs is more apparent in the wartime scenario. In this case, reducing Depot Shop Flow days results in greater NFMC reductions than an equal percentage decrease in the larger average RIT pipeline

segment. For example, Dyna-METRIC's problem parts summary listed LRU's L-1, L-2, and L-6 as having the greatest adverse impact on achieving FMC goals in the wartime scenario. For these LRUs and their indentured SRUs the mean DSF value is 16.8 days and the mean RIT value is 12.7 days. For these critical parts, the DSF pipeline segment is longer relative to the RIT segment. Equal percentage decreases over these two pipelines yield expected results when viewed with respect to only the critical components. A 50% decrease in the larger pipeline segment (DSF) yields a 4.2% NFMC decrease, while an equal percentage decrease in the shorter RIT segment produces a 3.4% decrease.

Presentation and Analysis of Research Question 4

Research question 4 addressed the usefulness of the AWP measure as a weapon system capability indicator. Dyna-METRIC's detailed segment report for problem parts and the base detailed segment report for the wartime scenario was used to answer this question.

For day 150 and all subsequent days of analysis, LRUs L-3 and L-4 were the top two LRUs in terms of AWP days with 3.54 and 2.84 units in AWP respectively. However, neither of these components had an impact on weapon system capability in the wartime scenario. L-3 had an initial base stock level of 11 units. On day 150 and subsequent days, 3.82 units were within segments of the base repair cycle pipeline leaving 7.18 servicable. L-4 had 12 units in stock

at the beginning of the run, 5.08 were absorbed by the base pipeline by day 150, leaving 6.92 servicable.

L-1 and L-6 were listed as parts which were adversely impacting weapon system capability. L-1 had an AWP value of .89 for day 150 with 0 stock at the base while L-6 had an AWP value of 1.06 (with an additional 2.10 in test/repair) with an initial base stock of 2 units. From the analysis of this scenario, the AWP statistic can only be viewed as an indicator of depot efficiency, not as a weapon system capability indicator. Given unlimited base stock, there is no impact at the base level resulting from depot repair cycle management.

Summary of Results

Four Depot Repair Cycle variables that are external to the base were tracked on an item-by-item basis within AFLC's D041 automated data base. For the LRUs and SRUs modeled, these variables represent 51.5 days, or 66% of the total mean repair cycle pipeline.

Large reductions were necessary in each pipeline segment to produce a measureable change in either total AWP days or the expected percentage of Not Fully Mission Capable (NFMC) aircraft. Depot Shop Flow reductions of 25%, 50%, and 75% produced total AWP decreases ranging from 5.6% to 7.6% in the peacetime scenario. The impact varied among individual LRUs, ranging from no impact for those LRUs already receiving adequate supply support, to a 6% AWP

decrease for each 25% Depot Shop Flow reduction for L-1, a problem LRU in both scenarios.

Similar percentage decreases were made in the Repairable Intransit pipeline segment producing AWP decreases ranging from 3.7% to 11% in peacetime and 3.0% to 8.9% in the war scenario. AWP reductions varied between scenarios because the amount of stock available to support the base repair process differed.

Reductions in the Supply to Maintenance pipeline segment yielded 3% to 9% AWP reduction in the peacetime scenario, and a 2.5% to 7.4% reduction in the wartime scenario.

The mean Serviceable Turn-in segment represented only 5% of the total mean pipeline length. AWP reductions resulting from a 75% reduction in this segment was 1.7% in peacetime and 1.5% in the war scenario.

Capability impact varied between the two scenarios. AWP reductions had less impact on mission capability in the peacetime scenario. Decreasing AWP delays allowed the E(% NFMC) aircraft to decrease from a baseline value of .202 to .194. In the wartime scenario, the E(% NFMC) aircraft value decreased from .175 to .165. Though the value in itself appears insignificant for a 15 aircraft scenario, it actually represents an additional 5 KC-135s when applied to the entire fleet.

AWP impacts capability only when inadequate stock exists to support the base repair process for problem parts.

High AWP levels for LRUs that were adequately stocked in the wartime scenario had no adverse impact on weapon system capability.

V. Summary, Conclusions, and Recommendations

Overview

The purpose of this chapter is to provide a summary of the research effort, present conclusions drawn from experimental results, and make recommendations for logistics managers and analysts concerning the use of Dyna-METRIC for assessing the base level impact of depot level repair process decisions.

Summary of Research Effort

Effective management of repairable item inventories is essential from both an economic and a systems capability standpoint. Economically, large inventories are not justifiable because repairable items are typically expensive and have low demand rates. From a capability standpoint, demand must be fulfilled from a limited inventory whose replenishment leadtime, while measured in months, often takes 2 to 3 years. The efficiency of the total repair cycle is a key element in maintaining an adequate serviceable spares inventory.

Analysis of KC-135A LRUs experiencing high base AWP delays indicated that the SRUs needed to support the base repair process were accumulating at the depot. A study conducted by the Air Force Logistics Management Center (AFLMC), focusing on base AWP, indicated that little

improvement could be achieved through base initiatives. A model was needed to assess the impact of depot initiatives on base AWP delays to determine which depot level improvements would yield the greatest base level impact.

Version 4 of Rand's Dyna-METRIC model was chosen because it allows a more complete treatment of depot variables than previous releases. This research effort involved the modeling of a weapon system composed of SRUs with high AWP histories. The purpose was to determine the impact on base AWP and weapon system capability caused by improving segments of the Depot Repair Cycle.

Two scenarios were constructed from KC-135A flying hour programs provided by SAC/LGL. One scenario represented a peacetime proficiency flying program with spares support available only from POS. The second scenario represented an overseas location with the same number of aircraft as previously modeled, flying a more intense program. Spares were available from both POS and WRM for this second scenario.

Each location was assumed to have RR and RRR maintenance capability in place. Depot stock and repair support were identical and uninterrupted in both scenarios. Pipeline values were initialized by having each base fly a peacetime program identical to its wartime program.

Data requirements were met through a variety of sources. Dyna-METRIC views an aircraft as a collection of parts. For this study, the collection of parts consisted of

11 of SAC's top 20 KC-135A LRUs for AWP delays. AFLC's D041 data base provided depot and base repair cycle times, NRTS percentages, and other item specific information. POS and WRM levels were extracted from the SAFE data base, then scaled to represent the support proportionate to a 15 aircraft scenario. Base stock for the peacetime scenario was reduced 25% across all items to remove the proportion of stock shared with EC-135s. Depot stock was reduced to the percentage that 15 KC-135A's represent out of the total number of aircraft supported by the depot for each component.

Baseline runs were conducted for each scenario. The effect of reducing the D041 depot repair cycle values of Repairable Intransit Time, Depot Shop Flow, Supply to Maintenance Days, and Serviceable Turn-in Days was evaluated on subsequent runs. Three model runs for each variable were made for both scenarios. Base AWP and weapon system capability shifts resulting from reducing each variable 25%, 50%, and 75% were measured.

Conclusions

Research Question 1. The first research question asked which repair cycle variables external to base most directly influenced total AWP delays for a specified set of LRUs. The D041 data base provided individual item values for four repair cycle variables external to the base: Repairable Intransit Days, Supply to Maintenance Days, Depot Shop Flow

Days, and Serviceable Turn-in Days. The actual amount of AWP reduction caused by decreases in these depot variables was dependent upon base stock levels and the percentage of the total pipeline represented by each segment. Repairable Intransit Days had the greatest impact in one scenario, while Depot Shop Flow reductions caused the greatest improvement in the other. This finding demonstrates the need for specifically tailoring a solution to each unique situation.

Research Question 2. This question asked how the total AWP days for those LRUs would be affected if the variables identified in question 1 were changed.

Changes in Depot Shop Flow yielded the largest AWP reduction for both scenarios for a given percentage decrease, followed by Repairable Intransit and Supply to Maintenance Days. The Serviceable Turn-in pipeline segment was too short in comparison to the total pipeline to yield any measureable AWP improvement. Comparison of the baseline with subsequent model runs, having reduced depot repair pipeline segments, indicated that large reductions in any single pipeline segment were necessary to produce any measurable AWP decreases. This finding suggests that large AWP improvements through depot repair initiatives alone are unlikely. Other initiatives, such as improving the percentage of SRUs repairable at base level and purchasing additional stock of both SRUs and LRUs, may be necessary.

AWP impact varied among individual LRUs. The effect of

reducing pipeline segments had no AWP impact for LRUs already receiving adequate depot support, but all problem LRUs responded to changes in the depot repair cycle. However, the amount of improvement that resulted from a fixed percentage decrease in a pipeline segment depended upon how large the altered segment was in relation to the total pipeline length. For example, decreasing the RIT pipeline segment caused the greatest AWP shift for some LRUs while reductions in DSF produced more pronounced results for others. This means that the benefits derived from improving one segment of the total pipeline depends largely upon the components (and their associated parameters) flowing through it. The relative insensitivity of AWP to depot repair cycle variables indicates that large depot level repair improvements may be required for nominal base level AWP improvements. In fact, adding stock may be more cost effective than changing depot variables.

Research Question 3. Research question 3 addressed the effect of pipeline segment reductions on actual weapon system capability.

The impact on capability was dependent upon the amount of stock available. In the peacetime scenario, only POS was available to support the flying hour program. Any LRU delayed in base repair impacted the NFMC rate because POS was depleted. When WRM stock was introduced, as in the second scenario, higher AWP levels were achieved without impacting capability. This means reductions in pipeline

segments themselves did not necessarily improve the system capability.

Research Question 4. Research question 4 was general in nature, addressing the usefulness of the AWP measure as a weapon system capability indicator.

AWP was found to be an unreliable capability indicator. High AWP levels indicate only that the repair process is receiving inadequate support. When large stock levels of LRUs are maintained, the repair process loses significance. This means that given enough base stock, the depot repair process could be eliminated entirely without impacting weapon system capability. In the second scenario, some LRUs which experienced high AWP delays had no adverse effect on capability because of their correspondingly higher stock levels.

Recommendations

Based on the conclusions drawn from research questions 1 and 2, it is recommended that depot repair cycle improvement efforts, if undertaken, be focused on the Depot Shop Flow and Repairable Intransit segments of the total repair cycle pipeline. These segments yielded the greatest base AWP reduction for the parts and scenarios modeled. Research question 2 further concluded that large reductions in any single pipeline segment may be necessary to produce significant base AWP improvements. Based on this conclusion, it is recommended that other solutions to the

AWP problem, such as increasing base stock levels of LRUs and SRUs, or increasing the percentage of SRUs repaired at base level also be considered.

Similar conclusions concerning enhancing weapon system capability were drawn from research question 3. For the set of LRUs evaluated, the greatest improvements in weapon system capability resulted from improving the Repairable Intransit pipeline segment for problem parts in the peacetime scenario, and the Depot Shop Flow segment in the wartime scenario. When weapon system capability must be increased within the constraint of existing repairable stock inventories, these pipeline segments should be the focus of improvement efforts. For the wartime scenario, it is recommended that Depot Shop Flow reductions be sought for LRU L-1 and SRUs S-3 and S-5. The Repairable Intransit pipeline segment should be decreased for SRU S-21. For the peacetime scenario, the greatest improvement within existing stock allocations can be obtained by reducing the Repairable In-Transit pipeline for SRU S-30.

Capability shortfalls can rarely be completely attributed to one cause. Transportation, repair capability, and stock levels at all levels of supply have an impact. For LRU L-1, the purchase of additional stock is recommended to compensate for its 80 day depot repair time. Serviceable stock levels for this LRU and its SRUs were approximately 15% of the D041 established required level.

This study was an analytical sensitivity analysis only.

The feasibility of actually reducing each pipeline segment was not addressed. A subsequent study that relates the benefits of increased capability to actual costs of implementing depot improvements should be conducted. The costs associated with equivalent capability increases due to increased depot capability and additional stock purchases should also be addressed.

Dyna-METRIC indicates that relatively large depot repair cycle improvements must be made to produce measureable improvements in weapon system capability. Validation of this aspect of the model should be further pursued through simulation modeling.

Appendix A: Glossary

<u>Term</u>	<u>Meaning</u>
AFLC	Air Force Logistics Command
AFLMC	Air Force Logistics Management Center
AFM	Air Force Manual
AWP	Awaiting Parts
CIRF	Central Intermediate Repair Facility
CONUS	Continental United States
DIFM	Due In From Maintenance
DSF	Depot Shop Flow
EAIM	End Article Item Manager
ESD	Estimated Shipping Date
FMC	Fully Mission Capable
LRU	Line Replaceable Unit
MAJCOM	Major Command
MDS	Mission/Design Number/Series
METRIC	Multi-Echelon Technique for Recoverable Item Control
NFMC	Not Fully Mission Capable
NRTS	Not Repairable This Station
PACAF	Pacific Air Forces
PMC	Partially Mission Capable
POS	Peacetime Operating Stock
QPA	Quantity Per Application
RIT	Repairable Intransit (Days)
RTS	Repairable This Station

SAC	Strategic Air Command
SMX	Supply to Maintenance (Days)
SRU	Shop Replaceable Unit
TRN	Serviceable Turn-in (Days)
WRM	War Reserve/Readiness Materiel
WRSK	War Readiness Spare Kit

Appendix B: KC-135A AWP Summary

LRU NAME	NUMBER	AWP TIME (Days)	REASON NOT MODELED
1560006075152FL	-	N/A	No SRUs
1630000585242	-	1236	Insufficient Data
1630004485560	-	914	No SRUs
1680001095730FL	L 1	1058	
1680006566170FL	L 2	6912	
5821011038155	L 3	630	
5821119450593	-	145	
5826001345972	L 4	2891	
5826004445276	-	N/A	Insufficient Data
5841010781344	-	1145	Insufficient Data
5841010537676	L 5	1413	
5841010568647	L 6	3352	
6615006731261	L 7	281	
5826009178679	L 8	1719	
5841010537874	L 9	2282	
5895000894522	L 10	4406	
6605005154834	-	7074	Insufficient Data
6615006118277	L 11	598	
6220006171843	-	896	No SRUs

Legend:

N/A = Data Not Available

Appendix C: Reparable Asset Control

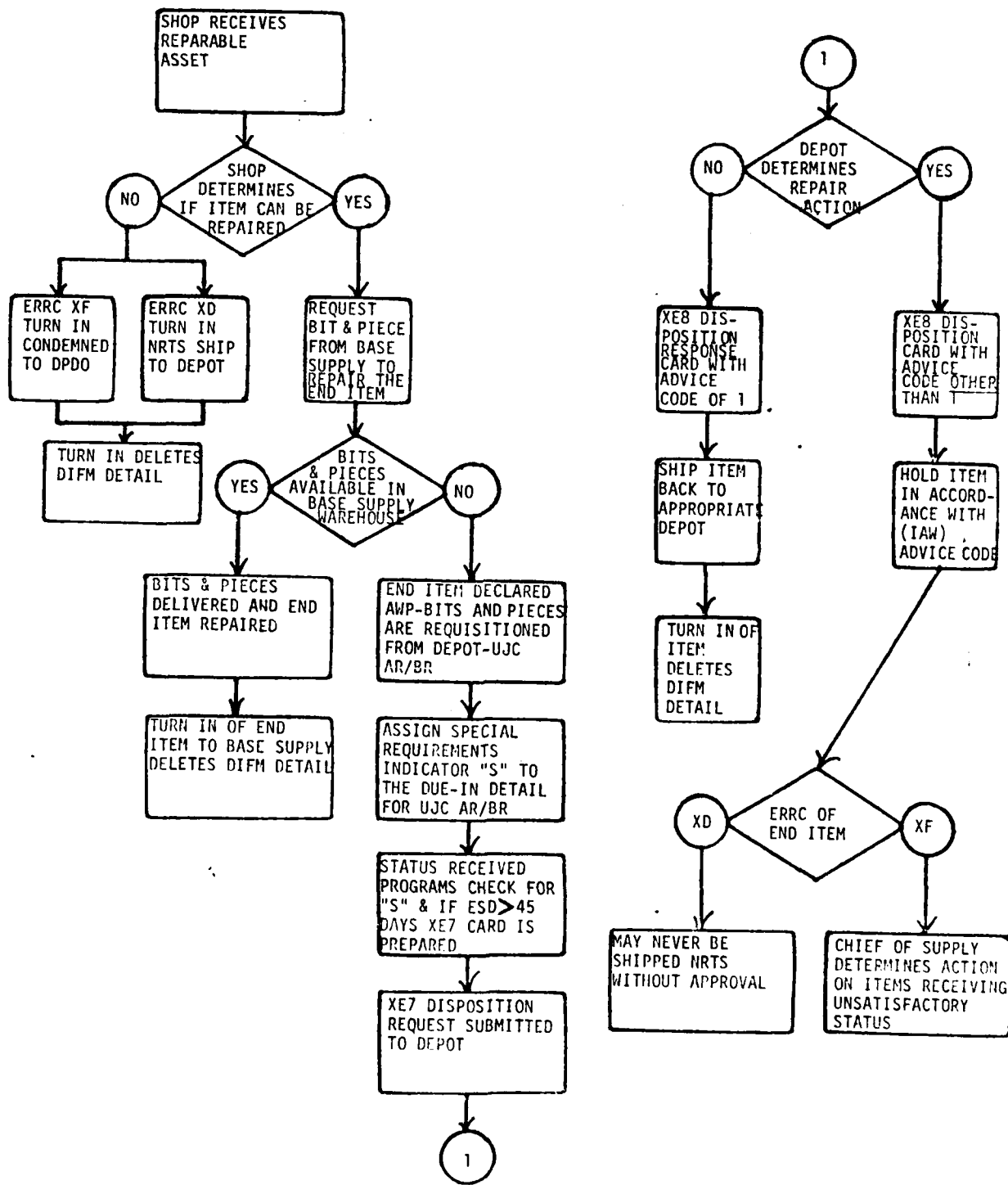

Source: (20:1-19)

Appendix D: World Wide Stock Levels

PART NAME	NUMBER	All Depots			All Bases								
		REQ'D/O.H.	%	SERV./UnSER.	REQ'D/O.H.	%	SERV./DIFM						
1680001095730FL	L 1	32	4	13%	3	1	75%	23	25	109%	5	20	20%
1560003367412	S 1	31	2	6%	1	1	50%	34	6	18%	4	2	67%
1560000682535FL	S 2	8	17	213%	3	14	17%	50	11	22%	8	3	73%
1560006317598FL	S 3	22	43	195%	2	41	105%	10	8	80%	6	2	75%
1650006123748	S 4	41	36	88%	6	30	17%	142	46	32%	39	7	95%
1680006590122	S 5	14	11	79%	5	6	45%	40	21	53%	16	5	76%
1680006566170FL	L 2	32	9	28%	4	5	44%	373	230	62%	141	89	61%
1680003044697FL	S 6	68	330	485%	326	4	99%	202	106	97%	187	9	95%
1680005049353FL	S 7	6	311	5183%	310	1	99%	29	30	97%	27	3	90%
581011038155	L 3	5	39	780%	24	15	61%	185	175	95%	155	20	88%
5821011038:67	S 8	9	49	544%	0	49	0%	71	21	30%	17	4	81%
5821011038175	S 9	1	39	3900%	37	2	94%	28	46	164%	45	1	98%
5821011038:76	S 10	11	40	364%	36	4	90%	37	46	124%	45	1	98%
5821011038177	S 11	1	42	4200%	39	3	93%	23	45	196%	45	0	100%
5826001345972	L 4	39	85	218%	17	68	20%	528	185	35%	158	27	85%
5826001031437	S 12	18	30	167%	0	30	0%	91	50	55%	38	12	76%
58260004517243	S 13	12	34	283%	0	34	0%	51	5	10%	5	0	100%
58260004570885	S 14	7	10	143%	0	2	80%	38	37	97%	35	2	94%
58260004637:60	S 15	5	19	380%	14	5	73%	66	69	105%	63	6	91%
58260004844870	S 16	6	11	183%	1	10	10%	34	35	103%	26	9	74%
5826000895156	S 17	2	4	200%	4	0	100%	18	31	172%	29	2	93%
5841010537676	L 5	72	104	144%	12	92	11%	524	250	488%	222	28	89%
5841010606714	S 18	1	5	500%	0	5	0%	16	37	231%	34	3	92%
5841010606824	S 19	2	3	150%	1	2	33%	15	30	200%	25	5	83%
5841010568647	L 6	69	69	100%	7	62	10%	766	336	44%	264	72	79%
5841010502480	S 20	5	12	240%	11	1	92%	30	74	247%	68	6	92%
5841010503079	S 21	51	46	90%	7	39	15%	130	21	16%	19	2	90%
5841010503080	S 22	6	54	900%	11	43	20%	22	36	164%	35	1	97%
5841010509421	S 23	8	14	175%	7	7	50%	61	78	128%	76	2	97%
58410105:2027	S 24	16	82	513%	2	80	02%	59	11	19%	6	5	54%
58410105:6339	S 25	21	50	238%	6	44	14%	65	23	35%	21	2	91%
5841010632765	S 26	5	4	80%	2	2	50%	50	63	126%	53	10	84%
66:5006731261	L 7	78	90	115%	8	82	09%	662	291	44%	273	18	94%
6615005350179	S 27	14	36	257%	35	1	97%	85	96	113%	95	1	99%
6615005350180	S 28	14	73	521%	68	5	93%	25	41	164%	40	1	98%
6615001934926	S 29	12	14	117%	3	11	21%	85	78	92%	77	1	99%
6615007112732	S 30	17	33	194%	19	14	57%	16	31	194%	26	5	84%
5826009178679	L 8	23	49	213%	15	34	31%	394	104	26%	83	21	80%
5826003023612	S 31	10	27	270%	5	22	18%	34	14	41%	11	3	78%
5826005:91723	S 32	7	100	1429%	16	84	16%	28	31	111%	25	6	81%
5826005:98327	S 33	3	135	4500%	16	119	12%	20	33	165%	32	1	97%
5826005:648701	S 34	3	242	8067%	12	230	05%	26	24	92%	24	0	100%

5841010537874	L 9	23	46	200%	6	40	13%	407	299	73%	264	35	88%
5841010493865	S 35	4	2	50%	0	2	0%	13	8	62%	8	0	100%
5841010503162	S 36	10	12	120%	5	7	58%	43	42	98%	42	0	100%
5841010503163	S 37	15	11	75%	9	2	81%	18	27	150%	26	1	96%
5841010503200	S 38	1	66	6600%	37	29	44%	4	6	150%	05	1	83%
5841010513891	S 39	7	5	71%	0	5	0%	47	51	109%	50	1	98%
5895000894522	L 10	61	150	246%	41	109	27%	1114	536	48%	456	80	85%
5895009463858	S 40	12	41	342%	5	36	12%	70	49	70%	20	25	51%
5895009468958	S 41	35	155	443%	78	77	50%	129	136	105%	128	8	94%
5895009479232	S 42	41	66	161%	6	60	9%	145	106	73%	81	25	76%
5895009490669	S 43	40	168	420%	72	96	43%	116	99	85%	86	13	87%
5895009497046	S 44	41	122	298%	1	121	1%	128	51	40%	31	20	61%
6615006118277	L 11	61	104	170%	13	91	13%	637	243	38%	231	12	95%
6615005091105	S 45	15	51	340%	44	7	86%	77	85	110%	84	1	99%
6615005350151	S 46	23	66	287%	49	17	74%	28	57	204%	56	1	99%
6615006531058	S 47	9	27	300%	20	7	74%	43	51	119%	51	0	100%

Appendix E: Input Stock Levels

PART NAME	NUMBER	KGUS			ESUN			DEPOT		
		REQOBJ	SERV	INPUT	REQOBJ	SERV	INPUT	REQOBJ	SERV	INPUT
1680001095730FL	L 1	0	0	0	0	0	0	5	3	0
1560003367412	S 1	3	1	1	3	1	1	0	0	0
1560000682535FL	S 2	2	0	0	0	0	0	1	3	0
1560006317598FL	S 3	1	1	1	0	0	0	1	2	0
1650006123748	S 4	4	0	0	8	3	3	22	5	0
1680006590122	S 5	0	0	0	0	0	0	0	3	0
1680006566170FL	L 2	5	0	0	21	10	10	1	2	0
1680003044697FL	S 6	11	7	6	8	7	7	0	320	60
1680005049353FL	S 7	0	0	0	3	4	4	0	309	6
5821011038167	S 8	2	0	0	3	3	3	1	0	0
5821011038175	S 9	1	0	1	1	1	1	0	27	1
5821011038176	S 10	1	1	1	1	1	1	5	36	1
5821011038177	S 11	1	1	1	1	1	1	0	39	1
5826001345972	L 4	6	1	0	34	12	12	8	12	1
5826001031437	S 12	5	2	2	3	3	3	3	0	0
5826004517243	S 13	7	0	0	2	0	0	3	0	0
5826004570085	S 14	5	3	2	2	1	1	3	7	1
5826004637160	S 15	2	2	2	1	2	2	1	14	0
5826004844870	S 16	2	1	1	4	4	4	3	1	0
582600895156	S 17	0	0	0	1	2	2	1	4	0
5841010537676	L 5	2	1	0	33	12	12	3	0	0
5841010606714	S 18	0	0	0	0	0	0	0	0	0
5841010606824	S 19	1	0	0	1	2	2	0	1	0
5841010568647	L 6	1	3	2	32	6	6	5	0	0
5841010502480	S 20	1	2	2	0	1	1	1	11	0
5841010503079	S 21	0	0	0	6	2	2	6	1	0
5841010503080	S 22	3	3	3	6	6	6	4	11	0
5841010509421	S 23	2	2	2	3	5	5	1	7	0
5841010512027	S 24	2	0	0	5	0	0	1	1	0
5841010516339	S 25	3	2	2	5	4	4	3	6	0
5841010632765	S 26	1	3	2	3	3	3	1	1	0
6615006731251	L 7	11	0	0	39	27	27	3	1	0
6615005350179	S 27	6	6	5	6	5	5	0	31	1
6615005350180	S 28	2	1	1	0	2	2	1	65	1
6615001934926	S 29	4	4	3	5	4	4	1	1	0
6615007112732	S 30	0	0	0	0	1	1	1	18	0
5826009178679	L 8	4	0	0	19	5	5	5	14	0
5826003023612	S 31	3	1	1	0	0	0	5	5	0
5826005191723	S 32	2	2	2	2	1	1	4	16	0
5826005198327	S 33	2	2	2	1	0	0	1	16	0
5826005648701	S 34	1	1	1	2	2	2	1	12	0

5841010537874	L 9	2	3	2	2	16	16	3	2	0
5841010493865	S 35	0	0	0	0	2	2	2	0	0
5841010503162	S 36	4	4	3	5	4	4	1	1	0
5841010503163	S 37	2	3	2	0	2	2	0	7	0
5841010503208	S 38	0	0	0	0	0	0	0	37	1
5841010513891	S 39	5	5	4	4	4	4	1	0	0
5895000894522	L 10	1	2	2	36	12	12	4	29	0
5895009463858	S 40	2	0	0	3	0	0	2	5	0
5895009468958	S 41	2	2	2	2	3	3	1	78	1
5895009479232	S 42	1	0	0	3	2	2	1	5	0
5895009490669	S 43	1	1	1	2	1	1	1	70	1
5895009497046	S 44	2	0	0	3	0	0	0	0	0
6615006118277	L 11	6	2	2	32	5	5	2	7	0
6615005091105	S 45	6	4	3	7	5	5	0	39	1
6615005350151	S 46	0	2	2	2	3	3	1	47	1
6615006531058	S 47	4	2	2	2	4	4	0	17	0

Legend: KGUS = Grissom AFB
EGUN = Mildenhall RAFB

Appendix F: Input Data Source Summary

Card	Item	Source
TRNS	Transportation Days to Depot	DO41 Reparable Intransit Days (Ave. for Each Depot)
SRTS	Sortie Rate	SAC LGL
FLHR	Flying Hours/Sortie	SAC LGL
TURN	Maximum Sortie Rate	SAC LGL
LRU/ SRU	Depot Name	DO41 Source of Repair Code
	Lowest Level of Repair	Base Repair assumed for all except those with 100% NRTS
	Quantity Per Acft	SAFE
	NRTS/Condemnation Indicator	Actions assumed after test except for 100% NRTS items
	Demand Rate/Flying Hour	DO41 OIM Depot Demand Rate
	Lone Base Repair Days	DO41 Base Repair Cycle Days
	Lone Base NRTS Rate	DO41 Base NRTS PCT Curr 24 Months
	Lone Base Condem- Rate	DO41 Base CNDM PCT Curr 24 Months
	Depot Repair Days	DO41 Reparable Intransit Days + Supply-Maintenance Days + Shop Flow Days + Serviceable Turn-in Days
	Depot Repair Limit	AFLC MAWR
	Depot Condemnation	DO41 Depot OH CNDM PCT
	Procurement Days	DO41 Production Leadtime + Administrative Leadtime
	Unit Price	DO41 Unit Price

INDT Quantity Per Next
 Higher Assembly

SAFE QPA (All LRUs had
(QPAs of 1)

STK Stock Level

SAFE

Appendix G: Depot Repair Cycle Baseline Input File

PART NAME	NUMBER	DSF	RIT	SMX	TRN	TOTAL
1680001095730FL	L 1	44	24	10	2	80
1560003367412	S 1	30	11	0	15	56
1560000682535FL	S 2	14	15	10	2	41
1560006317598FL	S 3	31	16	10	2	59
1650006123748	S 4	12	12	10	2	36
1680006590122	S 5	20	9	10	2	41
1680006566170FL	L 2	30	10	0	15	55
1680003044697FL	S 6	30	19	0	15	60
1680005049353FL	S 7	30	13	0	15	58
581011038155	L 3	11	7	10	2	30
5821011038167	S 8	23	6	10	2	41
5821011038175	S 9	8	7	10	2	27
5821011038176	S 10	8	8	10	2	28
5821011038177	S 11	8	7	10	2	27
5826001345972	L 4	5	8	10	2	25
5826001031437	S 12	5	12	10	2	29
5826004517243	S 13	5	11	10	2	28
5826004570885	S 14	4	12	10	2	28
5826004637160	S 15	4	11	10	2	27
5826004844870	S 16	4	12	10	2	28
5826008959156	S 17	4	11	10	2	27
5841010537676	L 5	10	9	10	2	31
5841010606714	S 18	6	13	10	2	31
5841010606824	S 19	5	14	10	2	31
5841010568647	L 6	7	10	10	2	29
5841010502480	S 20	5	11	10	2	28
5841010503079	S 21	6	9	10	2	31
5841010503080	S 22	4	14	10	2	30
5841010509421	S 23	4	11	10	2	27
5841010512027	S 24	5	14	10	2	31
5841010516339	S 25	5	12	10	2	29
5841010632765	S 26	6	11	10	2	29
6615006731261	L 7	11	11	10	2	34
6615005350179	S 27	8	14	10	2	34
6615005350180	S 28	8	15	10	2	35
6615001934926	S 29	8	14	10	2	34
6615007112732	S 30	8	14	10	2	34
5826009178679	L 8	7	13	10	2	32
5826003023612	S 31	5	9	10	2	26
5826005191723	S 32	4	14	10	2	30
5826005198327	S 33	5	12	10	2	29
5826005648701	S 34	4	10	10	2	26

5841010537874	L 9	9	7	10	2	28
5841010493865	S 35	4	12	10	2	28
5841010503162	S 36	4	11	10	2	27
5841010503163	S 37	4	11	10	2	27
5841010503208	S 38	5	15	10	2	32
5841010513891	S 39	5	11	10	2	28
5895000894522	L 10	7	10	10	2	29
5895009463858	S 40	4	15	10	2	31
5895009468958	S 41	4	12	10	2	28
5895009479232	S 42	4	13	10	2	29
5895009490669	S 43	4	13	10	2	29
5895009497046	S 44	4	13	10	2	29
6615006118277	L 11	9	11	10	2	32
6615005091105	S 45	8	14	10	2	34
6615005350151	S 46	8	15	10	2	35
6615006531058	S 47	8	17	10	2	37

Appendix H: Depot Repair Limit Data File

PART NAME	NUMBER	SOR	%	DRL (Units/Mo.)
1680001095730FL	L 1	CN	100%	N/A
1560003367412	S 1	CN	100%	N/A
1560000682535FL	S 2	OC	100%	N/A
1560006317598FL	S 3	OC	100%	N/A
1650006123748	S 4	SM	100%	68
1680006590122	S 5	SM	100%	62
1680006566170FL	L 2	SM	100%	N/A
1680003044697FL	S 6	CN	100%	31
1680005049353FL	S 7	CN	100%	92
582101038155	L 3	CN	100%	N/A
5821011038167	S 8	WR	100%	N/A
5821011038175	S 9	WR	100%	92
5821011038176	S 10	WR	100%	92
5821011038177	S 11	WR	100%	92
5826001345972	L 4	WR	100%	92
5826001031437	S 12	WR	100%	61
5826004517243	S 13	WR	100%	55
5826004570885	S 14	WR	100%	110
5826004637160	S 15	WR	100%	183
5826004844870	S 16	WR	100%	138
5826008959156	S 17	WR	100%	110
5841010537676	L 5	WR	100%	N/A
5841010606714	S 18	WR	100%	78
5841010606824	S 19	WR	100%	46
5841010568647	L 6	WR	100%	N/A
5841010502480	S 20	WR	100%	55
5841010503079	S 21	WR	100%	45
5841010503080	S 22	WR	100%	55
5841010509421	S 23	WR	100%	137
5841010512027	S 24	WR	100%	137
5841010516339	S 25	WR	100%	55
5841010632765	S 26	WR	100%	90
6615006731261	L 7	OC	100%	N/A
6615005350179	S 27	OC	100%	183
6615005350180	S 28	OC	100%	183
6615001934926	S 29	OC	100%	110
6615007112732	S 30	OC	100%	137
5826009178679	L 8	WR	100%	54
5826003023612	S 31	OC	100%	69
5826005191723	S 32	WR	100%	110
5826005198327	S 33	WR	100%	78
5826005648701	S 34	WR	100%	92

5841010537874	L 9	WR	100%	36
5841010493865	S 35	WR	100%	183
5841010503162	S 36	WR	100%	183
5841010503163	S 37	WR	100%	137
5841010503208	S 38	WR	100%	183
5841010513891	S 39	WR	100%	78
5895000894522	L 10	WR	100%	54
5895009463858	S 40	WR	100%	137
5895009468958	S 41	WR	100%	110
5895009479232	S 42	WR	100%	78
5895009490669	S 43	WR	100%	110
5895009497046	S 44	WR	100%	137
6615006118277	L 11	OC	100%	120
6615005091105	S 45	OC	100%	183
6615005350151	S 46	OC	100%	91
6615006531058	S 47	OC	100%	225

Legend:

OC = Oklahoma Air Logistics Center
SM = Sacramento Air Logistics Center
WR = Warner Robins Air Logistics Center
CN = Contractor Repaired
N/A = Data Not Available
SOR = Source of Repair

Appendix I: Dyna-METRIC Input Files

BASE AWP SENSITIVITY TO DEPOT REPAIR VARIABLES: PEACE SCENARIO BASELINE

01 0.5 14.0 0.0 VERSION 4.4 BL1BL2BL3BL4BL5

01 15 30 90 150 210 270 300 330 365

OPT

8 75
11 15 .85
15
20 90 90
23 10

DEPT

WRLC 0.00 999. 0.0 0.0 0.0 0.01 0.0
OCLC 0.00 999. 0.0 0.0 0.0 0.01 0.0
SMC 0.00 999. 0.0 0.0 0.0 0.01 0.0

BASE

KGUS 0.0 0.0 1.01 999. 0.0 0.00 999. 0.0 0.0 0.0 0.01 999. 0.0 1

TRNS

KGUS WRLC 0.0 11.0 0 0.0 999. 0.0

KGUS OCLC 0.0 14.5 0 0.0 999. 0.0

KGUS SMC 0.0 12.0 0 0.0 999. 0.0

ACFT

KGUS 15.0 115.0 999

FLHR

KGUS 3.3 1 3.3 999

SRTS

KGUS 1.0 1 1.0 999

TURN

KGUS 2.0 1 2.0 999

LRU

1680001095730FL OCLC 1 0 01 01 0 .00200 .00200 06.0 0.39 0.00 00.0 0.00 0.00

1680001095730FL 0.0 0.00 0.00 80.0 99.9 0.00 360. 360. 61079.00

1680006566170FL OCLC 1 0 01 01 0 .00287 .00287 08.0 0.18 0.00 00.0 0.00 0.00

1680006566170FL 0.0 0.00 0.00 55.0 99.9 0.02 750. 750. 5336.01

5821011038155 WRLC 1 0 01 01 0 .00087 .00087 03.0 0.21 0.00 00.0 0.00 0.00

5821011038155 0.0 0.00 0.00 30.0 99.9 0.00 420. 420. 1493.50

5826001345972 WRLC 1 0 02 02 0 .00276 .00276 04.0 0.20 0.00 00.0 0.00 0.00

5826001345972 0.0 0.00 0.00 25.0 99.9 0.00 480. 480. 4441.19

5841010537676 WRLC 1 0 01 01 0 .00352 .00352 04.0 0.32 0.00 00.0 0.00 0.00

5841010537676 0.0 0.00 0.00 31.0 99.9 0.00 390. 390. 15000.00

5841010568647 WRLC 1 0 01 01 0 .00518 .00518 05.0 0.20 0.00 00.0 0.00 0.00

5841010568647 0.0 0.00 0.00 29.0 99.9 0.00 420. 420. 25006.34

6615006731261 OCLC 1 0 01 01 0 .00415 .00415 04.0 0.55 0.00 00.0 0.00 0.00

6615006731261 0.0 0.00 0.00 34.0 99.9 0.00 480. 480. 3721.00

5826009178679 WRLC 1 0 01 01 0 .00302 .00302 05.0 0.25 0.00 00.0 0.00 0.00

5826009178679 0.0 0.00 0.00 32.0 99.9 0.00 420. 420. 2639.00

5841010537874 WRLC 1 0 01 01 0 .00267 .00267 04.0 0.17 0.00 00.0 0.00 0.00

5841010537874 0.0 0.00 0.00 29.0 99.9 0.00 330. 330. 15977.36

5895000894522 WRLC 1 0 01 01 0 .00531 .00531 04.0 0.10 0.00 00.0 0.00 0.00

5895000894522 0.0 0.00 0.00 29.0 99.9 0.00 180. 180. 3914.00

6615006118277 WRLC 1 0 01 01 0 .00503 .00503 04.0 0.38 0.00 00.0 0.00 0.00

6615006118277 0.0 0.00 0.00 32.0 99.9 0.00 480. 480. 4543.00

SRU

1560003367412 OCLC 1 0 01 0 .00034 .00034 11.0 0.93 0.00 00.0 0.00 0.00

1560003367412 0.0 0.00 0.00 56.0 99.9 0.00 720. 720. 3862.50

1560000682535FL OCLC 1 0 01 0 .00065 .00065 06.0 0.18 0.01 00.0 0.00 0.00

1560000682535FL 0.0 0.00 0.00 41.0 99.9 0.03 690. 690. 2837.65

1560006317598FL OCLC 1 0 01 0 .00009 .00009 07.0 0.50 0.00 00.0 0.00 0.00

1560006317598FL 0.0 0.00 0.00 59.0 99.9 0.16 999. 999. 10507.55

1650006123748 SMC 1 0 02 0 .00044 .00044 07.0 0.58 0.00 00.0 0.00 0.00

1650006123748 0.0 0.00 0.00 36.0 99.9 0.06 360. 360. 2838.00

1680006590122 SMC 1 0 01 0 .00039 .00039 05.0 0.69 0.00 00.0 0.00 0.00

1680006590122 0.0 0.00 0.00 41.0 99.9 0.01 660. 660. 6952.50

1680003044697FL OCLC 1 0 01 0 .00171 .00171 08.0 0.97 0.01 00.0 0.00 0.00

1680003044697FL 0.0 0.00 0.00 60.0 99.9 0.03 999. 999. 509.85

1680005049353FL OCLC 1 0 01 0 .00012 .00012 07.0 0.75 0.00 00.0 0.00 0.00

1680005049353FL 0.0 0.00 0.00 58.0 99.9 0.17 600. 600. 1342.86

5821011038167	WRLC 1 0 01	0 .00049 .00049 04.0 0.94	0.00 00.0 0.00 0.00
5821011038167	0.0 0.00 0.00	41.0 99.9 0.00 510. 510.	789.6
5821011038175	WRLC 3 0 01	1 .00004 .00004 00.0 1.00	0.00 00. 0.00 0.00
5821011038175	0.0 0.00 0.00	27.0 99.9 0.00 420. 420.	111.24
5821011038176	WRLC 3 0 01	1 .00025 .00025 00.0 1.00	0.00 00.0 0.00 0.00
5821011038176	0.0 0.00 0.00	28.0 99.9 0.00 300. 300.	117.42
5821011038177	WRLC 3 0 01	1 .00002 .00002 00.0 1.00	0.00 00.0 0.00 0.00
5821011038177	0.0 0.00 0.00	27.0 99.9 0.00 300. 300.	214.24
5826001031437	WRLC 1 0 02	0 .00048 .00048 06.0 0.63	0.00 00.0 0.00 0.00
5826001031437	0.0 0.00 0.00	29.0 99.9 0.00 810. 810.	3975.80
5826004517243	WRLC 1 0 02	0 .00022 .00022 06.0 0.90	0.05 00.0 0.00 0.00
5826004517243	0.0 0.00 0.00	28.0 99.9 0.00 960. 960.	3914.00
5826004570885	WRLC 1 0 02	0 .00021 .00021 07.0 0.33	0.00 00.0 0.00 0.00
5826004570885	0.0 0.00 0.00	28.0 99.9 0.00 420. 420.	268.10
5826004637160	WRLC 1 0 02	0 .00024 .00024 06.0 0.25	0.00 00.0 0.00 0.00
5826004637160	0.0 0.00 0.00	27.0 99.9 0.01 510. 510.	467.50
5826004844870	WRLC 1 0 02	0 .00020 .00020 07.0 0.36	0.00 00.0 0.00 0.00
5826004844870	0.0 0.00 0.00	28.0 99.9 0.00 690. 690.	1151.00
5826008959156	WRLC 1 0 02	0 .00013 .00013 06.0 0.27	0.00 00.0 0.00 0.00
5826008959156	0.0 0.00 0.00	27.0 99.9 0.00 420. 420.	505.10
5841010606714	WRLC 1 0 01	0 .00011 .00011 04.0 0.18	0.00 00.0 0.00 0.00
5841010606714	0.0 0.00 0.00	31.0 99.9 0.00 690. 690.	2502.00
5841010606824	WRLC 1 0 01	0 .00015 .00015 05.0 0.21	0.00 00.0 0.00 0.00
5841010606824	0.0 0.00 0.00	31.0 99.9 0.00 360. 360.	2194.93
5841010502480	WRLC 1 0 01	0 .00022 .00022 05.0 0.24	0.00 00.0 0.00 0.00
5841010502480	0.0 0.00 0.00	28.0 99.9 0.00 210. 210.	4254.00
5841010503079	WRLC 1 0 01	0 .00068 .00068 07.0 0.90	0.01 00.0 0.00 0.00
5841010503079	0.0 0.00 0.00	27.0 99.9 0.00 480. 480.	1044.42
5841010503080	WRLC 1 0 01	0 .00009 .00009 06.0 0.32	0.01 00.0 0.00 0.00
5841010503080	0.0 0.00 0.00	30.0 99.9 0.00 450. 450.	773.50
5841010509421	WRLC 1 0 01	0 .00015 .00015 04.0 0.93	0.00 00.0 0.00 0.00
5841010509421	0.0 0.00 0.00	27.0 99.9 0.01 360. 360.	326.51
5841010512027	WRLC 1 0 01	0 .00028 .00028 05.0 0.90	0.03 00.0 0.00 0.00
5841010512027	0.0 0.00 0.00	31.0 99.9 0.00 510. 510.	2946.76
5841010516339	WRLC 1 0 01	0 .00031 .00031 06.0 0.92	0.00 00.0 0.00 0.00
5841010516339	0.0 0.00 0.00	29.0 99.9 0.00 540. 540.	1717.00
5841010632765	WRLC 1 0 01	0 .00036 .00036 07.0 0.15	0.00 00.0 0.00 0.00
5841010632765	0.0 0.00 0.00	29.0 99.9 0.00 600. 600.	6556.98
6615005350179	OCLC 1 0 01	0 .00048 .00048 04.0 0.89	0.00 00.0 0.00 0.00
6615005350179	0.0 0.00 0.00	34.0 99.9 0.02 480. 480.	254.00
6615005350180	OCLC 1 0 01	0 .00058 .00058 03.0 0.93	0.00 00.0 0.00 0.00
6615005350180	0.0 0.00 0.00	35.0 99.9 0.01 480. 480.	539.00
6615005934926	OCLC 1 0 01	0 .00043 .00043 04.0 0.94	0.00 00.0 0.00 0.00
6615005934926	0.0 0.00 0.00	34.0 99.9 0.01 480. 480.	565.70
6615007112732	OCLC 1 0 01	0 .00065 .00065 03.0 0.88	0.00 00.0 0.00 0.00
6615007112732	0.0 0.00 0.00	34.0 99.9 0.00 480. 480.	810.30
5826003023612	WRLC 1 0 01	0 .00030 .00030 06.0 0.80	0.03 00.0 0.00 0.00
5826003023612	0.0 0.00 0.00	26.0 99.9 0.22 270. 270.	750.00
5826005191723	WRLC 1 0 01	0 .00034 .00034 06.0 0.37	0.00 00.0 0.00 0.00
5826005191723	0.0 0.00 0.00	30.0 99.9 0.00 420. 420.	438.00
5826005198327	WRLC 1 0 01	0 .00017 .00017 09.0 0.49	0.00 00.0 0.00 0.00
5826005198327	0.0 0.00 0.00	29.0 99.9 0.00 420. 420.	300.00
5826005648701	WRLC 1 0 01	0 .00014 .00014 06.0 0.50	0.00 00.0 0.00 0.00
5826005648701	0.0 0.00 0.00	26.0 99.9 0.00 420. 420.	397.00
5841010493865	WRLC 1 0 01	0 .00005 .00005 07.0 0.87	0.00 00.0 0.00 0.00
5841010493865	0.0 0.00 0.00	28.0 99.9 0.00 360. 360.	613.90
5841010503162	WRLC 1 0 01	0 .00007 .00007 04.0 0.91	0.00 00.0 0.00 0.00
5841010503162	0.0 0.00 0.00	27.0 99.9 0.00 390. 390.	363.59
5841010503163	WRLC 1 0 01	0 .00019 .00019 02.0 0.90	0.00 00.0 0.00 0.00
5841010503163	0.0 0.00 0.00	27.0 99.9 0.00 390. 390.	356.38
5841010503208	WRLC 1 0 01	0 .00003 .00003 07.0 0.82	0.00 00.0 0.00 0.00
5841010503208	0.0 0.00 0.00	32.0 99.9 0.00 480. 480.	280.40
5841010513891	WRLC 1 0 01	0 .00024 .00024 04.0 0.91	0.00 00.0 0.00 0.00
5841010513891	0.0 0.00 0.00	28.0 99.9 0.00 390. 390.	820.90
5895009463858	WRLC 1 0 01	0 .00018 .00018 05.0 0.45	0.00 00.0 0.00 0.00
5895009463858	0.0 0.00 0.00	31.0 99.9 0.00 780. 780.	257.30

5895009468958	WRLC	1 0 01	0 .00040	.00040	04.0	0.75	0.00	00.0	0.00	0.00
5895009468958		0.0	0.00	0.00	28.0	99.9	0.00	510.	510.	1306.00
5895009479232	WRLC	1 0 01	0 .00073	.00073	04.0	0.46	0.00	00.0	0.00	0.00
5895009479232		0.0	0.00	0.00	29.0	99.9	0.00	630.	630.	1566.37
5895009490669	WRLC	1 0 01	0 .00058	.00058	04.0	0.57	0.00	00.0	0.00	0.00
5895009490669		0.0	0.00	0.00	29.0	99.9	0.00	720.	720.	3195.97
5895009497046	WRLC	1 0 01	0 .00057	.00057	06.0	0.56	0.00	00.0	0.00	0.00
5895009497046		0.0	0.00	0.00	29.0	99.9	0.00	600.	600.	1299.86
6615005091105	OCLC	1 0 01	0 .00042	.00042	04.0	0.94	0.00	00.0	0.00	0.00
6615005091105		0.0	0.00	0.00	34.0	99.9	0.03	480.	480.	1412.00
6615005350151	OCLC	1 0 01	0 .00080	.00080	04.0	0.93	0.00	00.0	0.00	0.00
6615005350151		0.0	0.00	0.00	35.0	99.9	0.01	480.	480.	577.00
6615006531058	OCLC	1 0 01	0 .00020	.00020	03.0	0.90	0.00	00.0	0.00	0.00
6615006531058		0.0	0.00	0.00	37.0	99.9	0.00	480.	480.	199.00

INDT

1680001095730FL	1L	1	.0001
1560003367412	OS	1	.0001
1560000682535FL	OS	1	.0700
1560006317598FL	OS	1	.0001
1650006123748	OS	2	.0001
1680006590122	OS	1	.0001
1680006566170FL	1L	1	.0001
1680003044697FL	OS	1	.0001
1680005049353FL	OS	1	.0001
5821011038155	1L	1	.0001
5821011038167	OS	1	.0001
5821011038175	OS	1	.0001
5821011038176	OS	1	.0001
5821011038177	OS	1	.0001
5826001345972	1L	2	.0001
5826001031437	OS	1	.0001
5826004517243	OS	1	.0001
5826004570885	OS	1	.0001
5826004637160	OS	1	.0001
5826004844870	OS	1	.0001
5826008959156	OS	1	.0001
5841010537676	1L	1	.0001
5841010606714	OS	1	.0001
5841010606824	OS	1	.0001
5841010568647	1L	1	.0001
5841010502480	OS	1	.0001
5841010503079	OS	1	.0001
5841010503080	OS	1	.0001
5841010509421	OS	1	.0001
5841010512027	OS	1	.0001
5841010516339	OS	1	.0001
5841010632765	OS	1	.0001
6615006731261	1L	1	.0001
6615005350179	OS	1	.0001
6615005350180	OS	1	.0001
6615005934926	OS	1	.0001
6615007112732	OS	1	.0001
5826009178679	1L	1	.0001
5826003023612	OS	1	.0001
5826005191723	OS	1	.0100
5826005198327	OS	1	.0001
5826005648701	OS	1	.0001
5841010537874	1L	1	.0001
5841010493865	OS	1	.0001
5841010503162	OS	1	.0001
5841010503163	OS	1	.0001
5841010503208	OS	1	.0001
5841010513891	OS	1	.0001
5895000894522	1L	1	.0001
5895009463858	OS	1	.0001
5895009468958	OS	1	.0001

5895009479232	OS	1	.0001
5895009490669	OS	1	.0001
5895009497046	OS	1	.0001
6615006118277	1L	1	.0001
6615005091105	OS	1	.0001
6615005350151	OS	1	.0001
6615006531058	OS	1	.0001
STK			
1680001095730FL	KGUS00000	OCLC00000	
1560003367412	KGUS00001	OCLC00000	
1560000682535FL	KGUS00000	OCLC00000	
1560006317598FL	KGUS00001	OCLC00000	
1650006123748	KGUS00000	OCLC00000	
1680006590122	KGUS00000	SMLC00000	
1680006566170FL	KGUS00000	OCLC00000	
1680003044697FL	KGUS00005	OCLC00006	
1680005049353FL	KGUS00000	OCLC00006	
5821011038155	KGUS00001	WRLC00000	
5821011038167	KGUS00000	WRLC00000	
5821011038175	KGUS00001	WRLC00001	
5821011038176	KGUS00001	WRLC00001	
5821011038177	KGUS00001	WRLC00001	
5826001345972	KGUS00001	WRLC00000	
5826001031437	KGUS00002	WRLC00000	
5826004517243	KGUS00000	WRLC00000	
5826004570885	KGUS00002	WRLC00000	
5826004637160	KGUS00002	WRLC00000	
5826004844870	KGUS00001	WRLC00000	
5826008959156	KGUS00000	WRLC00000	
5841010537676	KGUS00000	WRLC00000	
5841010606714	KGUS00000	WRLC00000	
5841010606824	KGUS00000	WRLC00000	
5841010568647	KGUS00002	WRLC00000	
5841010502480	KGUS00001	WRLC00000	
5841010503079	KGUS00000	WRLC00000	
5841010503080	KGUS00002	WRLC00000	
5841010509421	KGUS00002	WRLC00000	
5841010512027	KGUS00000	WRLC00000	
5841010516339	KGUS00002	WRLC00000	
5841010632765	KGUS00002	WRLC00000	
6615006731261	KGUS00000	OCLC00000	
6615005350179	KGUS00005	OCLC00001	
6615005350180	KGUS00001	OCLC00001	
6615005934926	KGUS00003	OCLC00000	
6615007112732	KGUS00000	OCLC00000	
5826009178679	KGUS00000	WRLC00000	
5826003023612	KGUS00001	WRLC00000	
5826005191723	KGUS00002	WRLC00000	
5826005198327	KGUS00002	WRLC00000	
5826005648701	KGUS00001	WRLC00000	
5841010537874	KGUS00002	WRLC00000	
5841010493865	KGUS00000	WRLC00000	
5841010503162	KGUS00003	WRLC00000	
5841010503163	KGUS00002	WRLC00000	
5841010503208	KGUS00000	WRLC00001	
5841010513891	KGUS00004	WRLC00000	
5895000894522	KGUS00002	WRLC00000	
5895009463858	KGUS00000	WRLC00000	
5895009468958	KGUS00002	WRLC00001	
5895009479232	KGUS00000	WRLC00000	
5895009490669	KGUS00001	WRLC00001	
5895009497046	KGUS00000	WRLC00000	
6615006118277	KGUS00002	OCLC00000	
6615005091105	KGUS00003	OCLC00001	
6615005350151	KGUS00002	OCLC00001	
6615006531058	KGUS00002	OCLC00000	
END			

BASE AWP SENSITIVITY TO DEPOT REPAIR VARIABLES: WAR SCENARIO BASELINE

01 0.5 14.0 0.0 VERSION 4.4 BL1BL2BL3BL4BL5

01 15 30 90 150 210 270 300 330 365

OPT

8 75
11 15 .85
15
20 90 90
23 10

DEPT

WRLC						0.00	999.	0.0	0.0	0.0	0.01	0.0		
OCLC						0.00	999.	0.0	0.0	0.0	0.01	0.0		
SMLC						0.00	999.	0.0	0.0	0.0	0.01	0.0		
BASE														
EGUN		0.0	0.0	1.01	999.	0.0	0.00	999.	0.0	0.0	0.01	999.	0.0	0
TRNS														
EGUN	WRLC	0.0	11.0	0	0.0	999.	0.0							
EGUN	OCLC	0.0	14.5	0	0.0	999.	0.0							
EGUN	SMLC	0.0	12.0	0	0.0	999.	0.0							
ACFT														
EGUN	15.0	115.0	999											
FLHR														
EGUN	3.0	1	3.0	999										
SRTS														
EGUN	2.0	1	2.0	999										
TURN														
EGUN	2.5	1	2.5	999										

LRU

1680001095730FL	OCLC	1	0	01	01	0	.00200	.00200	06.0	0.39	0.00	00.0	0.00	0.00
1680001095730FL		0.0	0.00	0.00	80.0	99.9	0.00	360.	360.	61079.00				
1680006566170FL	OCLC	1	0	01	01	0	.00287	.00287	08.0	0.18	0.00	00.0	0.00	0.00
1680006566170FL		0.0	0.00	0.00	55.0	99.9	0.02	750.	750.	5336.01				
5821011038155	WRLC	1	0	01	01	0	.00087	.00087	03.0	0.21	0.00	00.0	0.00	0.00
5821011038155		0.0	0.00	0.00	30.0	99.9	0.00	420.	420.	1493.50				
5826001345972	WRLC	1	0	02	02	0	.00276	.00276	04.0	0.20	0.00	00.0	0.00	0.00
5826001345972		0.0	0.00	0.00	25.0	99.9	0.00	480.	480.	4441.19				
5841010537676	WRLC	1	0	01	01	0	.00352	.00352	04.0	0.32	0.00	00.0	0.00	0.00
5841010537676		0.0	0.00	0.00	31.0	99.9	0.00	390.	390.	15000.00				
5841010568647	WRLC	1	0	01	01	0	.00518	.00518	05.0	0.20	0.00	00.0	0.00	0.00
5841010568647		0.0	0.00	0.00	29.0	99.9	0.00	420.	420.	25006.34				
6615006731261	OCLC	1	0	01	01	0	.00415	.00415	04.0	0.55	0.00	00.0	0.00	0.00
6615006731261		0.0	0.00	0.00	34.0	99.9	0.00	480.	480.	3721.00				
5826009178679	WRLC	1	0	01	01	0	.00302	.00302	05.0	0.25	0.00	00.0	0.00	0.00
5826009178679		0.0	0.00	0.00	32.0	99.9	0.00	420.	420.	2639.00				
5841010537874	WRLC	1	0	01	01	0	.00267	.00267	04.0	0.17	0.00	00.0	0.00	0.00
5841010537874		0.0	0.00	0.00	29.0	99.9	0.00	330.	330.	15977.36				
5895000894522	WRLC	1	0	01	01	0	.00531	.00531	04.0	0.10	0.00	00.0	0.00	0.00
5895000894522		0.0	0.00	0.00	29.0	99.9	0.00	180.	180.	3914.00				
6615006118277	WRLC	1	0	01	01	0	.00503	.00503	04.0	0.38	0.00	00.0	0.00	0.00
6615006118277		0.0	0.00	0.00	32.0	99.9	0.00	480.	480.	4543.00				

SRU

1560003367412	OCLC	1	0	01		0	.00034	.00034	11.0	0.93	0.00	00.0	0.00	0.00
1560003367412		0.0	0.00	0.00	56.0	99.9	0.00	720.	720.	3862.50				
1560000682535FL	OCLC	1	0	01		0	.00065	.00065	06.0	0.18	0.01	00.0	0.00	0.00
1560000682535FL		0.0	0.00	0.00	41.0	99.9	0.03	690.	690.	2837.65				
1560006317598FL	OCLC	1	0	01		0	.00009	.00009	07.0	0.50	0.00	00.0	0.00	0.00
1560006317598FL		0.0	0.00	0.00	59.0	99.9	0.16	999.	999.	10507.55				
1650006123748	SMLC	1	0	02		0	.00044	.00044	07.0	0.56	0.00	00.0	0.00	0.00
1650006123748		0.0	0.00	0.00	36.0	99.9	0.06	360.	360.	2838.00				
1680006590122	SMLC	1	0	01		0	.00039	.00039	05.0	0.69	0.00	00.0	0.00	0.00
1680006590122		0.0	0.00	0.00	41.0	99.9	0.01	660.	660.	6952.50				
1680003044697FL	OCLC	1	0	01		0	.00171	.00171	08.0	0.97	0.01	00.0	0.00	0.00
1680003044697FL		0.0	0.00	0.00	60.0	99.9	0.03	999.	999.	509.85				
1680005049353FL	OCLC	1	0	01		0	.00012	.00012	07.0	0.75	0.00	00.0	0.00	0.00
1680005049353FL		0.0	0.00	0.00	58.0	99.9	0.17	600.	600.	1342.86				

5821011038167	WRLC 1 0 01	0 .00049 .00049 04.0 0.94	0.00 00.0 0.00 0.00
5821011038167	0.0 0.00 0.00	41.0 99.9 0.00 510. 510.	789.67
5821011038175	WRLC 3 0 01	1 .00004 .00004 00.0 1.00	0.00 00.0 0.00 0.00
5821011038175	0.0 0.00 0.00	27.0 99.9 0.00 420. 420.	111.24
5821011038176	WRLC 3 0 01	1 .00025 .00025 00.0 1.00	0.00 00.0 0.00 0.00
5821011038176	0.0 0.00 0.00	28.0 99.9 0.00 300. 300.	117.42
5821011038177	WRLC 3 0 01	1 .00002 .00002 00.0 1.00	0.00 00.0 0.00 0.00
5821011038177	0.0 0.00 0.00	27.0 99.9 0.00 300. 300.	214.24
5826001031437	WRLC 1 0 02	0 .00048 .00048 06.0 0.63	0.00 00.0 0.00 0.00
5826001031437	0.0 0.00 0.00	29.0 99.9 0.00 810. 810.	3975.80
5826004517243	WRLC 1 0 02	0 .00022 .00022 06.0 0.90	0.05 00.0 0.00 0.00
5826004517243	0.0 0.00 0.00	28.0 99.9 0.00 960. 960.	3914.00
5826004570885	WRLC 1 0 02	0 .00021 .00021 07.0 0.33	0.00 00.0 0.00 0.00
5826004570885	0.0 0.00 0.00	28.0 99.9 0.00 420. 420.	268.10
5826004637160	WRLC 1 0 02	0 .00024 .00024 06.0 0.25	0.00 00.0 0.00 0.00
5826004637160	0.0 0.00 0.00	27.0 99.9 0.01 510. 510.	467.50
5826004844870	WRLC 1 0 02	0 .00020 .00020 07.0 0.36	0.00 00.0 0.00 0.00
5826004844870	0.0 0.00 0.00	28.0 99.9 0.00 690. 690.	1151.00
5826008959156	WRLC 1 0 02	0 .00013 .00013 06.0 0.27	0.00 00.0 0.00 0.00
5826008959156	0.0 0.00 0.00	27.0 99.9 0.00 420. 420.	505.10
5841010606714	WRLC 1 0 01	0 .00011 .00011 04.0 0.18	0.00 00.0 0.00 0.00
5841010606714	0.0 0.00 0.00	31.0 99.9 0.00 690. 690.	2502.00
5841010606824	WRLC 1 0 01	0 .00015 .00015 05.0 0.21	0.00 00.0 0.00 0.00
5841010606824	0.0 0.00 0.00	31.0 99.9 0.00 360. 360.	2194.93
5841010502480	WRLC 1 0 01	0 .00022 .00022 05.0 0.24	0.00 00.0 0.00 0.00
5841010502480	0.0 0.00 0.00	28.0 99.9 0.00 210. 210.	4254.00
5841010503079	WRLC 1 0 01	0 .00068 .00068 07.0 0.90	0.01 00.0 0.00 0.00
5841010503079	0.0 0.00 0.00	27.0 99.9 0.00 480. 480.	1044.42
5841010503080	WRLC 1 0 01	0 .00009 .00009 06.0 0.32	0.01 00.0 0.00 0.00
5841010503080	0.0 0.00 0.00	30.0 99.9 0.00 450. 450.	773.50
5841010509421	WRLC 1 0 01	0 .00015 .00015 04.0 0.93	0.00 00.0 0.00 0.00
5841010509421	0.0 0.00 0.00	27.0 99.9 0.01 360. 360.	326.51
5841010512027	WRLC 1 0 01	0 .00028 .00028 05.0 0.90	0.03 00.0 0.00 0.00
5841010512027	0.0 0.00 0.00	31.0 99.9 0.00 510. 510.	2946.76
5841010516339	WRLC 1 0 01	0 .00031 .00031 06.0 0.92	0.00 00.0 0.00 0.00
5841010516339	0.0 0.00 0.00	29.0 99.9 0.00 540. 540.	1717.00
5841010632765	WRLC 1 0 01	0 .00036 .00036 07.0 0.15	0.00 00.0 0.00 0.00
5841010632765	0.0 0.00 0.00	29.0 99.9 0.00 600. 600.	6556.98
6615005350179	OCLC 1 0 01	0 .00048 .00048 04.0 0.89	0.00 00.0 0.00 0.00
6615005350179	0.0 0.00 0.00	34.0 99.9 0.02 480. 480.	254.00
6615005350180	OCLC 1 0 01	0 .00058 .00058 03.0 0.93	0.00 00.0 0.00 0.00
6615005350180	0.0 0.00 0.00	35.0 99.9 0.01 480. 480.	539.00
6615005934926	OCLC 1 0 01	0 .00043 .00043 04.0 0.94	0.00 00.0 0.00 0.00
6615005934926	0.0 0.00 0.00	34.0 99.9 0.01 480. 480.	565.70
6615007112732	OCLC 1 0 01	0 .00065 .00065 03.0 0.88	0.00 00.0 0.00 0.00
6615007112732	0.0 0.00 0.00	34.0 99.9 0.00 480. 480.	810.30
5826003023612	WRLC 1 0 01	0 .00030 .00030 06.0 0.80	0.03 00.0 0.00 0.00
5826003023612	0.0 0.00 0.00	26.0 99.9 0.22 270. 270.	750.00
5826005191723	WRLC 1 0 01	0 .00034 .00034 06.0 0.37	0.00 00.0 0.00 0.00
5826005191723	0.0 0.00 0.00	30.0 99.9 0.00 420. 420.	438.00
5826005198327	WRLC 1 0 01	0 .00017 .00017 09.0 0.49	0.00 00.0 0.00 0.00
5826005198327	0.0 0.00 0.00	29.0 99.9 0.00 420. 420.	300.00
5826005648701	WRLC 1 0 01	0 .00014 .00014 06.0 0.50	0.00 00.0 0.00 0.00
5826005648701	0.0 0.00 0.00	26.0 99.9 0.00 420. 420.	397.00
5841010493865	WRLC 1 0 01	0 .00005 .00005 07.0 0.87	0.00 00.0 0.00 0.00
5841010493865	0.0 0.00 0.00	28.0 99.9 0.00 360. 360.	613.90
5841010503162	WRLC 1 0 01	0 .00007 .00007 04.0 0.91	0.00 00.0 0.00 0.00
5841010503162	0.0 0.00 0.00	27.0 99.9 0.00 390. 390.	363.59
5841010503163	WRLC 1 0 01	0 .00019 .00019 02.0 0.90	0.00 00.0 0.00 0.00
5841010503163	0.0 0.00 0.00	27.0 99.9 0.00 390. 390.	356.38
5841010503208	WRLC 1 0 01	0 .00003 .00003 07.0 0.82	0.00 00.0 0.00 0.00
5841010503208	0.0 0.00 0.00	32.0 99.9 0.00 480. 480.	280.40
5841010513891	WRLC 1 0 01	0 .00024 .00024 04.0 0.91	0.00 00.0 0.00 0.00
5841010513891	0.0 0.00 0.00	28.0 99.9 0.00 390. 390.	820.90
5895009463858	WRLC 1 0 01	0 .00018 .00018 05.0 0.45	0.00 00.0 0.00 0.00
5895009463858	0.0 0.00 0.00	31.0 99.9 0.00 780. 780.	257.30

AD-R161 570

A DYNA-METRIC ANALYSIS OF BASE AWAITING PARTS (AMP)
SENSITIVITY TO DEPOT (U) AIR FORCE INST OF TECH
WRIGHT-PATTERSON AF OH SCHOOL OF SYST L E HUBER
SEP 85 AFIT/GLM/LSM/855-37 F/G 15/5

2/2

UNCLASSIFIED

NL

							END					
							FORM					
							ONE					

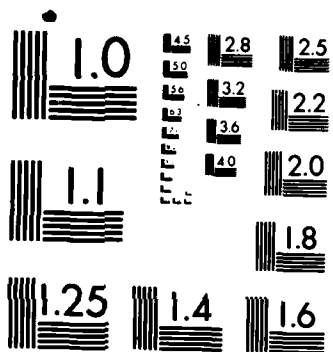

MICROCOPY RESOLUTION TEST CHART
NATIONAL BUREAU OF STANDARDS-1963-A

5895009468958	WRLC 1 0 01	0 .00040 .00040 04.0 0.75 0.00 00.0 0.00 0.00
5895009468958	0.0 0.00 0.00	28.0 99.9 0.00 510. 510. 1306.00
5895009479232	WRLC 1 0 01	0 .00073 .00073 04.0 0.46 0.00 00.0 0.00 0.00
5895009479232	0.0 0.00 0.00	29.0 99.9 0.00 630. 630. 1566.37
5895009490669	WRLC 1 0 01	0 .00058 .00058 04.0 0.57 0.00 00.0 0.00 0.00
5895009490669	0.0 0.00 0.00	29.0 99.9 0.00 720. 720. 3195.97
5895009497046	WRLC 1 0 01	0 .00057 .00057 06.0 0.56 0.00 00.0 0.00 0.00
5895009497046	0.0 0.00 0.00	29.0 99.9 0.00 600. 600. 1299.86
6615005091105	DCLC 1 0 01	0 .00042 .00042 04.0 0.94 0.00 00.0 0.00 0.00
6615005091105	0.0 0.00 0.00	34.0 99.9 0.03 480. 480. 1412.00
6615005350151	DCLC 1 0 01	0 .00080 .00080 04.0 0.93 0.00 00.0 0.00 0.00
6615005350151	0.0 0.00 0.00	35.0 99.9 0.01 480. 480. 577.00
6615006531058	DCLC 1 0 01	0 .00020 .00020 03.0 0.90 0.00 00.0 0.00 0.00
6615006531058	0.0 0.00 0.00	37.0 99.9 0.00 480. 480. 199.00

INDT

1680001095730FL	1L	1 .0001
1560003367412	OS	1 .0001
1560000682535FL	OS	1 .0700
1560006317598FL	OS	1 .0001
1650006123748	OS	2 .0001
1680006590122	OS	1 .0001
1680006566170FL	1L	1 .0001
1680003044697FL	OS	1 .0001
1680005049353FL	OS	1 .0001
5821011038155	1L	1 .0001
5821011038167	OS	1 .0001
5821011038175	OS	1 .0001
5821011038176	OS	1 .0001
5821011038177	OS	1 .0001
5826001345972	1L	2 .0001
5826001031437	OS	1 .0001
5826004517243	OS	1 .0001
5826004570885	OS	1 .0001
5826004637160	OS	1 .0001
5826004844870	OS	1 .0001
5826008959156	OS	1 .0001
5841010537676	1L	1 .0001
5841010606714	OS	1 .0001
5841010606824	OS	1 .0001
5841010568647	1L	1 .0001
5841010502480	OS	1 .0001
5841010503079	OS	1 .0001
5841010503080	OS	1 .0001
5841010509421	OS	1 .0001
5841010512027	OS	1 .0001
5841010516339	OS	1 .0001
5841010632765	OS	1 .0001
6615006731261	1L	1 .0001
6615005350179	OS	1 .0001
6615005350180	OS	1 .0001
6615005934926	OS	1 .0001
6615007112732	OS	1 .0001
5826009178679	1L	1 .0001
5826003023612	OS	1 .0001
5826005191723	OS	1 .0100
5826005198327	OS	1 .0001
5826005648701	OS	1 .0001
5841010537874	1L	1 .0001
5841010493865	OS	1 .0001
5841010503162	OS	1 .0001
5841010503163	OS	1 .0001
5841010503208	OS	1 .0001
5841010513891	OS	1 .0001
5895000894522	1L	1 .0001
5895009463858	OS	1 .0001
5895009468958	OS	1 .0001

5895009479232	OS	1	.0001
5895009490669	OS	1	.0001
5895009497046	OS	1	.0001
6615006118277	1L	1	.0001
6615005091105	OS	1	.0001
6615005350151	OS	1	.0001
6615006531058	OS	1	.0001
STK			
1680001095730FL	EGUN00000	OCLC00000	
1560003367412	EGUN00001	OCLC00000	
1560000682535FL	EGUN00000	OCLC00000	
1560006317598FL	EGUN00000	OCLC00000	
1650006123748	EGUN00003	OCLC00000	
1680006590122	EGUN00000	SMLC00000	
1680006566170FL	EGUN00010	OCLC00000	
1680003044697FL	EGUN00007	OCLC00006	
1680005049353FL	EGUN00004	OCLC00006	
5821011038155	EGUN00011	WRLC00000	
5821011038167	EGUN00003	WRLC00000	
5821011038175	EGUN00001	WRLC00001	
5821011038176	EGUN00001	WRLC00001	
5821011038177	EGUN00001	WRLC00001	
5826001345972	EGUN00012	WRLC00000	
5826001031437	EGUN00003	WRLC00000	
5826004517243	EGUN00000	WRLC00000	
5826004570885	EGUN00001	WRLC00000	
5826004637160	EGUN00002	WRLC00000	
5826008959156	EGUN00002	WRLC00000	
5826004844870	EGUN00004	WRLC00000	
5841010537676	EGUN00012	WRLC00000	
5841010606714	EGUN00000	WRLC00000	
5841010606824	EGUN00006	WRLC00000	
5841010568647	EGUN00002	WRLC00000	
5841010502480	EGUN00001	WRLC00000	
5841010503079	EGUN00002	WRLC00000	
5841010503080	EGUN00006	WRLC00000	
5841010509421	EGUN00005	WRLC00000	
5841010512027	EGUN00000	WRLC00000	
5841010516339	EGUN00004	WRLC00000	
5841010632765	EGUN00003	WRLC00000	
6615006731261	EGUN00027	OCLC00000	
6615005350179	EGUN00005	OCLC00001	
6615005350180	EGUN00002	OCLC00001	
6615005934926	EGUN00004	OCLC00000	
6615007112732	EGUN00001	OCLC00000	
5826009178679	EGUN00000	WRLC00000	
5826003023612	EGUN00000	WRLC00000	
5826005191723	EGUN00001	WRLC00000	
5826005198327	EGUN00000	WRLC00000	
5826005648701	EGUN00002	WRLC00000	
5841010537874	EGUN00016	WRLC00000	
5841010493865	EGUN00002	WRLC00000	
5841010503162	EGUN00005	WRLC00000	
5841010503163	EGUN00002	WRLC00000	
5841010503208	EGUN00000	WRLC00001	
5841010513891	EGUN00004	WRLC00000	
5895000894522	EGUN00012	WRLC00000	
5895009463858	EGUN00000	WRLC00000	
5895009468958	EGUN00003	WRLC00001	
5895009479232	EGUN00002	WRLC00000	
5895009490669	EGUN00001	WRLC00001	
5895009497046	EGUN00000	WRLC00000	
6615006118277	EGUN00005	OCLC00000	
6615005091105	EGUN00005	OCLC00001	
6615005350151	EGUN00003	OCLC00001	
6615006531058	EGUN00004	OCLC00000	
END			

Appendix J: Sensitivity Analysis Results

TABLE VIII

Peacetime Scenario Baseline

(Expected Base AWP Quantity / Performance)

Day	1	15	30	90	150	210	270	300	330	365
L 1 BOOM	.84	==>	==>	==>	==>	==>	==>	==>	==>	.84
L 2 NOZZLE	3.26	.84	.30	.13	==>	==>	==>	==>	==>	.13
L 3 CONTROL	2.85	1.44	1.27	1.22	==>	==>	==>	==>	==>	1.22
L 4 ALTIMETER	1.56	==>	==>	==>	==>	==>	==>	==>	==>	1.56
L 5 ANT APN59E	.07	==>	==>	==>	==>	==>	==>	==>	==>	.07
L 6 RT APN59E	1.24	==>	==>	==>	==>	==>	==>	==>	==>	1.24
L 7 COUPLER	.66	==>	==>	==>	==>	==>	==>	==>	==>	.66
L 8 RCVRTAPN69	.38	==>	==>	==>	==>	==>	==>	==>	==>	.38
L 9 IND APN59E	.08	==>	==>	==>	==>	==>	==>	==>	==>	.08
L 10 RT728APX64	.73	==>	==>	==>	==>	==>	==>	==>	==>	.73
L 11 AMPLIFIER	.21	.09	.06	.05	==>	==>	==>	==>	==>	.05
TOTALS	11.08	7.93	7.19	6.96	6.96	==>	==>	==>	==>	.96
Probability (15% NFMC	.059	.251	.312	.330	.331	==>	==>	==>	==>	.331
Probability Achieve Sorties	.915	.998	.999	.999	==>	==>	==>	==>	==>	.999
FMC- 85% CONF.	8	11	11	11	==>	==>	==>	==>	==>	11
E(NFMC)	4.836	3.274	3.077	3.03	3.029	==>	==>	==>	==>	3.029
EXP. % NFMC	.322	.218	.205	.202	==>	==>	==>	==>	==>	.202
E(SORTIES) EXP.	14.78	15.0	15.0	15.0	==>	==>	==>	==>	==>	15.0
SORTIES / ACFT	1.338	1.278	1.261	1.257	1.256	==>	==>	==>	==>	1.256

TABLE IX

25% Reduction DSF - Peacetime Scenario

(Expected Base AWP Quantity / Performance)

Day	1	15	30	90	150	210	270	300	330	365
L 1 BOOM	.78	==>	==>	==>	==>	==>	==>	==>	==>	.78
L 2 NOZZLE	2.82	.64	.20	.09	==>	==>	==>	==>	==>	.09
L 3 CONTROL	2.85	1.44	1.27	1.22	==>	==>	==>	==>	==>	1.22
L 4 ALTIMETER	1.54	==>	==>	==>	==>	==>	==>	==>	==>	1.54
L 5 ANT APN59E	.07	==>	==>	==>	==>	==>	==>	==>	==>	.07
L 6 RT APN59E	1.21	==>	==>	==>	==>	==>	==>	==>	==>	1.21
L 7 COUPLER	.64	==>	==>	==>	==>	==>	==>	==>	==>	.64
L 8 RCVRTAPN69	.37	==>	==>	==>	==>	==>	==>	==>	==>	.37
L 9 IND APN59E	.08	==>	==>	==>	==>	==>	==>	==>	==>	.08
L 10 RT728APX64	.71	==>	==>	==>	==>	==>	==>	==>	==>	.71
L 11 AMPLIFIER	.19	.09	.06	.04	==>	==>	==>	==>	==>	.04
TOTALS	10.46	7.57	6.93	6.75	==>	==>	==>	==>	==>	6.75
Probability (15% NFMC	.082	.202	.334	.347	==>	==>	==>	==>	==>	.347
Probability Achieve Sorties	.946	.998	.999	.999	==>	==>	==>	==>	==>	.999
FMC- 85% CONF.	9	11	11	==>	==>	==>	==>	==>	==>	11
E(NFMC)	4.482	3.170	3.018	2.985	==>	==>	==>	==>	==>	2.985
EXP. % NFMC	.299	.211	.201	.199	==>	==>	==>	==>	==>	.199
E(SORTIES) EXP.	14.88	15.00	==>	==>	==>	==>	==>	==>	==>	15.00
SORTIES / ACFT	1.329	1.269	1.256	1.252	==>	==>	==>	==>	==>	1.252

TABLE X

50% Reduction DSF - Peacetime Scenario

(Expected Base AWP Quantity / Performance)

Day	1	15	30	90	150	210	270	300	330	365
L 1 BOOM	.72	==)	==)	==)	==)	==)	==)	==)	==)	.72
L 2 NOZZLE	2.82	.64	.20	.09	==)	==)	==)	==)	==)	.09
L 3 CONTROL	2.05	1.44	1.27	1.22	==)	==)	==)	==)	==)	1.22
L 4 ALTIMETER	1.52	==)	==)	==)	==)	==)	==)	==)	==)	1.52
L 5 ANT APN59E	.07	==)	==)	==)	==)	==)	==)	==)	==)	.07
L 6 RT APN59E	1.17	==)	==)	==)	==)	==)	==)	==)	==)	1.17
L 7 COUPLER	.61	==)	==)	==)	==)	==)	==)	==)	==)	.61
L 8 RCVRTAPN69	.37	==)	==)	==)	==)	==)	==)	==)	==)	.37
L 9 IND APN59E	.08	==)	==)	==)	==)	==)	==)	==)	==)	.08
L 10 RT728APX64	.70	==)	==)	==)	==)	==)	==)	==)	==)	.70
L 11 AMPLIFIER	.17	.08	.05	.04	==)	==)	==)	==)	==)	.04
TOTALS	10.28	7.40	6.76	6.59	==)	==)	==)	==)	==)	6.59
Probability (15% NFMC	.085	.292	.346	.360	==)	==)	==)	==)	==)	.360
Probability Achieve Sorties	.946	.999	==)	==)	==)	==)	==)	==)	==)	.999
FMC- 85% CONF.	9	11	==)	==)	==)	==)	==)	==)	==)	11
E(NFMC)	4.470	3.140	2.985	2.951	==)	==)	==)	==)	==)	2.951
EXP. % NFMC	.298	.209	.199	.197	==)	==)	==)	==)	==)	.197
E(SORTIES) EXP.	14.88	15.00	==)	==)	==)	==)	==)	==)	==)	15.00
SORTIES / ACFT	1.328	1.267	1.252	1.249	==)	==)	==)	==)	==)	1.249

TABLE XI

75% Reduction DSF - Peacetime Scenario

(Expected Base AWP Quantity / Performance)

Day	1	15	30	90	150	210	270	300	330	365
L 1 BOOM	.70	=)	=)	=)	=)	=)	=)	=)	=)	.70
L 2 NOZZLE	1.99	.35	.12	.07	=)	=)	=)	=)	=)	.07
L 3 CONTROL	2.05	1.44	1.27	1.22	=)	=)	=)	=)	=)	1.22
L 4 ALTIMETER	1.50	=)	=)	=)	=)	=)	=)	=)	=)	1.50
L 5 ANT APNS9E	.07	=)	=)	=)	=)	=)	=)	=)	=)	.07
L 6 RT APNS9E	1.13	=)	=)	=)	=)	=)	=)	=)	=)	1.13
L 7 COUPLER	.58	=)	=)	=)	=)	=)	=)	=)	=)	.58
L 8 RCVRTAPN69	.36	=)	=)	=)	=)	=)	=)	=)	=)	.36
L 9 IND APNS9E	.00	=)	=)	=)	=)	=)	=)	=)	=)	.00
L 10 RT728APX64	.68	=)	=)	=)	=)	=)	=)	=)	=)	.68
L 11 AMPLIFIER	.16	.07	.05	.04	=)	=)	=)	=)	=)	.04
TOTALS	9.30	6.96	6.54	6.43	=)	=)	=)	=)	=)	6.43
Probability (15% NFMC	.141	.331	.363	.370	=)	=)	=)	=)	=)	.370
Probability Achieve Sorties	.982	.909	.999	=)	=)	=)	=)	=)	=)	.999
FMC- 85% CONF.	10	11	=)	=)	=)	=)	=)	=)	=)	11
E(NFMC)	3.886	3.025	2.942	2.924	=)	=)	=)	=)	=)	2.924
EXP. % NFMC	.259	.202	.196	.195	=)	=)	=)	=)	=)	.195
E(SORTIES) EXP.	14.97	15.00	=)	=)	=)	=)	=)	=)	=)	15.00
SORTIES / ACFT	1.312	1.256	1.248	1.247	=)	=)	=)	=)	=)	1.247

TABLE XII

25% Reduction RIT - Peacetime Scenario

(Expected Base AWP Quantity / Performance)

Day	1	15	30	90	150	210	270	300	330	365
L 1 BOOM	.81	=)	=)	=)	=)	=)	=)	=)	=)	.81
L 2 NOZZLE	3.04	.73	.25	.10	=)	=)	=)	=)	=)	.10
L 3 CONTROL	2.05	1.44	1.27	1.22	=)	=)	=)	=)	=)	1.22
L 4 ALTIMETER	1.52	=)	=)	=)	=)	=)	=)	=)	=)	1.52
L 5 ANT APNS9E	.07	=)	=)	=)	=)	=)	=)	=)	=)	.07
L 6 RT APNS9E	1.19	=)	=)	=)	=)	=)	=)	=)	=)	1.19
L 7 COUPLER	.62	=)	=)	=)	=)	=)	=)	=)	=)	.62
L 8 RCVRTAPN69	.37	=)	=)	=)	=)	=)	=)	=)	=)	.37
L 9 IND APNS9E	.08	=)	=)	=)	=)	=)	=)	=)	=)	.08
L 10 RT728APX64	.68	=)	=)	=)	=)	=)	=)	=)	=)	.68
L 11 AMPLIFIER	.18	.08	.05	.04	=)	=)	=)	=)	=)	.04
TOTALS	10.61	7.59	6.91	6.70	=)	=)	=)	=)	=)	6.70
Probability (15% NFMC	.071	.273	.331	.347	=)	=)	=)	=)	=)	.347
Probability Achieve Sorties	.932	.998	.999	=)	=)	=)	=)	=)	=)	.999
FMC- 85% CONF.	9	11	=)	=)	=)	=)	=)	=)	=)	11
E(NFMC)	4.650	3.202	3.026	2.985	=)	=)	=)	=)	=)	2.985
EXP. % NFMC	.310	.213	.202	.199	=)	=)	=)	=)	=)	.199
E(SORTIES) EXP.	14.83	15.00	=)	=)	=)	=)	=)	=)	=)	15.00
SORTIES / ACFT	1.333	1.272	1.256	1.252	=)	=)	=)	=)	=)	1.252

TABLE XIII

50% Reduction RIT - Peacetime Scenario

(Expected Base AWP Quantity / Performance)

Day	1	15	30	90	150	210	270	300	330	365
L 1 BOOM	.79	=)	=)	=)	=)	=)	=)	=)	=)	.79
L 2 NOZZLE	2.82	.64	.28	.09	=)	=)	=)	=)	=)	.09
L 3 CONTROL	2.85	1.44	1.27	1.22	=)	=)	=)	=)	=)	1.22
L 4 ALTIMETER	1.48	=)	=)	=)	=)	=)	=)	=)	=)	1.48
L 5 ANT APNS9E	.86	=)	=)	=)	=)	=)	=)	=)	=)	.86
L 6 RT APNS9E	1.13	=)	=)	=)	=)	=)	=)	=)	=)	1.13
L 7 COUPLER	.57	=)	=)	=)	=)	=)	=)	=)	=)	.57
L 8 RCVRTAPN69	.36	=)	=)	=)	=)	=)	=)	=)	=)	.36
L 9 IND APNS9E	.87	=)	=)	=)	=)	=)	=)	=)	=)	.87
L 10 RT728APX64	.63	=)	=)	=)	=)	=)	=)	=)	=)	.63
L 11 AMPLIFIER	.15	=)	=)	=)	=)	=)	=)	=)	=)	.15
TOTALS	10.11	7.32	6.60	6.43	=)	=)	=)	=)	=)	6.43
Probability (15% NFMC	.085	.295	.350	.363	.364	=)	=)	=)	=)	.364
Probability Achieve Sorties	.946	.999	=)	=)	=)	=)	=)	=)	=)	.999
FMC- 85% CONF.	9	11	=)	=)	=)	=)	=)	=)	=)	11x
E(NFMC)	4.467	3.134	2.977	2.943	=)	=)	=)	=)	=)	2.943
EXP. % NFMC	.298	.289	.198	.196	=)	=)	=)	=)	=)	.196
E(SORTIES) EXP.	14.88	15.00	=)	=)	=)	=)	=)	=)	=)	15.00
SORTIES / ACFT	1.328	1.266	1.252	1.248	=)	=)	=)	=)	=)	1.248

TABLE XIV

75% Reduction RIT - Peacetime Scenario

(Expected Base AWP Quantity / Performance)

Day	1	15	30	90	150	210	270	300	330	365
L 1 BOOM	.77	==)	==)	==)	==)	==)	==)	==)	==)	.77
L 2 NOZZLE	2.60	.55	.17	.09	==)	==)	==)	==)	==)	.09
L 3 CONTROL	2.05	1.44	1.27	1.22	==)	==)	==)	==)	==)	1.22
L 4 ALTIMETER	1.43	==)	==)	==)	==)	==)	==)	==)	==)	1.43
L 5 ANT APN59E	.06	==)	==)	==)	==)	==)	==)	==)	==)	.06
L 6 RT APN59E	1.08	==)	==)	==)	==)	==)	==)	==)	==)	1.08
L 7 COUPLER	.53	==)	==)	==)	==)	==)	==)	==)	==)	.53
L 8 RCVRTAPN69	.34	==)	==)	==)	==)	==)	==)	==)	==)	.34
L 9 IND APN59E	.07	==)	==)	==)	==)	==)	==)	==)	==)	.07
L 10 RT720APX64	.58	==)	==)	==)	==)	==)	==)	==)	==)	.58
L 11 AMPLIFIER	.12	.05	.04	.03	==)	==)	==)	==)	==)	.03
TOTALS	9.63	6.90	6.34	6.20	==)	==)	==)	==)	==)	6.20
Probability (15% NFMC	.101	.317	.368	.378	.379	==)	==)	==)	==)	.379
Probability Achieve Sorties	.958	.999	==)	==)	==)	==)	==)	==)	==)	.999
FMC- 85% CONF.	9	11	==)	==)	==)	==)	==)	==)	==)	11
E(NFMC)	4.295	3.070	2.931	2.905	2.904	==)	==)	==)	==)	2.904
EXP. % NFMC	.286	.205	.195	.194	==)	==)	==)	==)	==)	.194
E(SORTIES) EXP.	14.91	15.00	==)	==)	==)	==)	==)	==)	==)	15.00
SORTIES / ACFT	1.323	1.260	1.247	1.245	==)	==)	==)	==)	==)	1.245

TABLE XV

25% Reduction SMX - Peacetime Scenario

(Expected Base AWP Quantity / Performance)

Day	1	15	30	90	150	210	270	300	330	365
L 1 BOOM	.82	==>	==>	==>	==>	==>	==>	==>	==>	.82
L 2 NOZZLE	3.26	.84	.30	.13	==>	==>	==>	==>	==>	.13
L 3 CONTROL	2.05	1.44	1.27	1.22	==>	==>	==>	==>	==>	1.22
L 4 ALTIMETER	1.52	==>	==>	==>	==>	==>	==>	==>	==>	1.52
L 5 ANT APN59E	.07	==>	==>	==>	==>	==>	==>	==>	==>	.07
L 6 RT APN59E	1.18	==>	==>	==>	==>	==>	==>	==>	==>	1.18
L 7 COUPLER	.63	==>	==>	==>	==>	==>	==>	==>	==>	.63
L 8 RCVRTAPN69	.37	==>	==>	==>	==>	==>	==>	==>	==>	.37
L 9 IND APN59E	.08	==>	==>	==>	==>	==>	==>	==>	==>	.08
L 10 RT728APX64	.69	==>	==>	==>	==>	==>	==>	==>	==>	.69
L 11 AMPLIFIER	.20	.09	.06	.05	==>	==>	==>	==>	==>	.05
TOTALS	10.87	7.73	6.99	6.76	==>	==>	==>	==>	==>	6.76
Probability (15% NFMC	.061	.261	.324	.343	==>	==>	==>	==>	==>	.343
Probability Achieve Sorties	.915	.998	.999	==>	==>	==>	==>	==>	==>	.999
FMC- 85% CONF.	8	11	==>	==>	==>	==>	==>	==>	==>	11
E(NFMC)	4.825	3.246	3.045	2.996	==>	==>	==>	==>	==>	2.996
EXP. % NFMC	.322	.316	.283	.200	==>	==>	==>	==>	==>	.200
E(SORTIES) EXP.	14.78	15.20	==>	==>	==>	==>	==>	==>	==>	15.00
SORTIES / ACFT	1.338	1.276	1.258	1.253	==>	==>	==>	==>	==>	1.253

TABLE XVI

50% Reduction SMX - Peacetime Scenario

(Expected Base AWP Quantity / Performance)

Day	1	15	30	90	150	210	270	300	330	365
1 BOOM	.80	==)	==)	==)	==)	==)	==)	==)	==)	.80
2 NOZZLE	3.26	.84	.30	.13	==)	==)	==)	==)	==)	.13
3 CONTROL	2.05	1.44	1.27	1.22	==)	==)	==)	==)	==)	1.22
4 ALTIMETER	1.48	==)	==)	==)	==)	==)	==)	==)	==)	1.48
5 ANT APN59E	.06	==)	==)	==)	==)	==)	==)	==)	==)	.06
6 RT APN59E	1.12	==)	==)	==)	==)	==)	==)	==)	==)	1.12
7 COUPLER	.60	==)	==)	==)	==)	==)	==)	==)	==)	.60
8 RCVRTAPN69	.35	==)	==)	==)	==)	==)	==)	==)	==)	.35
9 IND APN59E	.08	==)	==)	==)	==)	==)	==)	==)	==)	.08
10 RT728APX64	==)	.69	==)	==)	==)	==)	==)	==)	==)	.69
11 AMPLIFIER	.17	.07	.05	.04	==)	==)	==)	==)	==)	.04
TOTALS	10.66	7.53	6.80	6.57	==)	==)	==)	==)	==)	6.57
Probability (.15% NFMC)	.064	.070	.335	==)	==)	==)	==)	==)	==)	.335
Probability Achieve Sorties	.915	.998	.999	==)	==)	==)	==)	==)	==)	.999
FMC- 85% CONF.	8	11	==)	==)	==)	==)	==)	==)	==)	11
E(NFMC)	4.815	3.220	3.015	2.965	2.964	==)	==)	==)	==)	2.964
EXP. % NFMC	.321	.215	.201	.198	==)	==)	==)	==)	==)	.198
E(SORTIES) EXP.	14.78	15.00	==)	==)	==)	==)	==)	==)	==)	15.00
SORTIES / ACFT	1.337	1.273	1.255	1.251	==)	==)	==)	==)	==)	1.251

TABLE XVII

75% Reduction SMX - Peacetime Scenario

(Expected Base AWP Quantity / Performance)

Day	1	15	30	90	150	210	270	300	330	365
L 1 BOOM	.78	==)	==)	==)	==)	==)	==)	==)	==)	.78
L 2 NOZZLE	3.26	.84	.30	.13	==)	==)	==)	==)	==)	.13
L 3 CONTROL	2.05	1.44	1.27	1.22	==)	==)	==)	==)	==)	1.22
L 4 ALTIMETER	1.44	==)	==)	==)	==)	==)	==)	==)	==)	1.44
L 5 ANT APNS9E	.06	==)	==)	==)	==)	==)	==)	==)	==)	.06
L 6 RT APNS9E	1.06	==)	==)	==)	==)	==)	==)	==)	==)	1.06
L 7 COUPLER	.57	==)	==)	==)	==)	==)	==)	==)	==)	.57
L 8 RCVRTAPN69	.34	==)	==)	==)	==)	==)	==)	==)	==)	.34
L 9 IND APNS9E	.07	==)	==)	==)	==)	==)	==)	==)	==)	.07
L 10 RT728APX64	.62	==)	==)	==)	==)	==)	==)	==)	==)	.62
L 11 AMPLIFIER	.15	.07	.04	.03	==)	==)	==)	==)	==)	.03
TOTALS	10.40	7.29	6.55	6.32	==)	==)	==)	==)	==)	6.32
Probability (15% NFMC	.066	.280	.348	.368	==)	==)	==)	==)	==)	.368
Probability Achieve Sorties	.915	.998	.999	==)	==)	==)	==)	==)	==)	.999
FMC- 85% CONF.	8	11	==)	==)	==)	==)	==)	==)	==)	11
E(NFMC)	4.005	3.192	2.981	2.930	2.929	==)	==)	==)	==)	2.929
EXP. % NFMC	.320	.213	.199	.195	==)	==)	==)	==)	==)	.195
E(SORTIES) EXP.	14.78	15.00	==)	==)	==)	==)	==)	==)	==)	15.00
SORTIES / ACFT	1.336	1.271	1.252	1.247	==)	==)	==)	==)	==)	1.247

TABLE XVIII

25% Reduction TRN - Peacetime Scenario

(Expected Base AWP Quantity / Performance)

Day	1	15	30	90	150	210	270	300	330	365
L 1 BOOM	.84	=>	=>	=>	=>	=>	=>	=>	=>	.84
L 2 NOZZLE	3.04	.73	.25	.10	=>	=>	=>	=>	=>	.10
L 3 CONTROL	2.05	1.44	1.27	1.22	=>	=>	=>	=>	=>	1.22
L 4 ALTIMETER	1.55	=>	=>	=>	=>	=>	=>	=>	=>	1.55
L 5 ANT APN59E	.07	=>	=>	=>	=>	=>	=>	=>	=>	.07
L 6 RT APN59E	1.23	=>	=>	=>	=>	=>	=>	=>	=>	1.23
L 7 COUPLER	.66	=>	=>	=>	=>	=>	=>	=>	=>	.66
L 8 RCVRTAPN69	.38	=>	=>	=>	=>	=>	=>	=>	=>	.38
L 9 IND APN59E	.08	=>	=>	=>	=>	=>	=>	=>	=>	.08
L 10 RT728APX64	.72	=>	=>	=>	=>	=>	=>	=>	=>	.72
L 11 AMPLIFIER	.20	.09	.06	.05	=>	=>	=>	=>	=>	.05
TOTALS	10.82	7.79	7.11	6.90	=>	=>	=>	=>	=>	6.90
Probability (15% NFMC	.069	.263	.320	.335	=>	=>	=>	=>	=>	.335
Probability Achieve Sorties	.932	.998	.999	=>	=>	=>	=>	=>	=>	.999
FMC- 85% CONF.	9	11	=>	=>	=>	=>	=>	=>	=>	11
E(NFMC)	4.661	3.229	3.057	3.017	3.016	=>	=>	=>	=>	3.016
EXP. % NFMC	.311	.215	.204	.201	=>	=>	=>	=>	=>	.201
E(SORTIES) EXP.	14.83	15.00	=>	=>	=>	=>	=>	=>	=>	15.00
SORTIES / ACFT	1.334	1.275	1.259	1.255	=>	=>	=>	=>	=>	1.255

TABLE XIX

50% Reduction TRN - Peacetime Scenario

(Expected Base AWP Quantity / Performance)

Day	1	15	30	90	150	210	270	300	330	365
L 1 BOOM	.83	=)	=)	=)	=)	=)	=)	=)	=)	.83
L 2 NOZZLE	2.82	.64	.20	.09	=)	=)	=)	=)	=)	.09
L 3 CONTROL	2.05	1.44	1.27	1.22	=)	=)	=)	=)	=)	1.22
L 4 ALTIMETER	1.55	=)	=)	=)	=)	=)	=)	=)	=)	1.55
L 5 ANT APN59E	.07	=)	=)	=)	=)	=)	=)	=)	=)	.07
L 6 RT APN59E	1.22	=)	=)	=)	=)	=)	=)	=)	=)	1.22
L 7 COUPLER	.65	=)	=)	=)	=)	=)	=)	=)	=)	.65
L 8 RCVRTAPN69	.37	=)	=)	=)	=)	=)	=)	=)	=)	.37
L 9 IND APN59E	.08	=)	=)	=)	=)	=)	=)	=)	=)	.08
L 10 RT728APX64	.71	=)	=)	=)	=)	=)	=)	=)	=)	.71
L 11 AMPLIFIER	.20	.09	.06	.05	=)	=)	=)	=)	=)	.05
TOTALS	10.55	7.65	7.01	6.84	=)	=)	=)	=)	=)	6.84
Probability (15% NFMC	.000	.275	.326	.339	=)	=)	=)	=)	=)	.339
Probability Achieve Sorties	.946	.998	.999	=)	=)	=)	=)	=)	=)	.999
FMC- 85% CONF.	9	11	=)	=)	=)	=)	=)	=)	=)	11
E(NFMC)	4.491	3.189	3.039	3.006	=)	=)	=)	=)	=)	3.006
EXP. % NFMC	.299	.213	.203	.200	=)	=)	=)	=)	=)	.200
E(SORTIES) EXP.	14.88	15.00	=)	=)	=)	=)	=)	=)	=)	15.00
SORTIES / ACFT	1.330	1.271	1.258	1.254	=)	=)	=)	=)	=)	1.254

TABLE XX

75% Reduction TRN - Peacetime Scenario

(Expected Base AWP Quantity / Performance)

Day	1	15	30	90	150	210	270	300	330	365
L 1 BOOM	.83	=>	=>	=>	=>	=>	=>	=>	=>	.83
L 2 NOZZLE	2.60	.55	.17	.09	=>	=>	=>	=>	=>	.09
L 3 CONTROL	2.05	1.44	1.27	1.22	=>	=>	=>	=>	=>	1.22
L 4 ALTIMETER	1.54	=>	=>	=>	=>	=>	=>	=>	=>	1.54
L 5 ANT APN59E	.07	=>	=>	=>	=>	=>	=>	=>	=>	.07
L 6 RT APN59E	1.21	=>	=>	=>	=>	=>	=>	=>	=>	1.21
L 7 COUPLER	.64	=>	=>	=>	=>	=>	=>	=>	=>	.64
L 8 RCVRTAPN69	.37	=>	=>	=>	=>	=>	=>	=>	=>	.37
L 9 IND APN59E	.00	=>	=>	=>	=>	=>	=>	=>	=>	.00
L 10 RT728APX64	.71	=>	=>	=>	=>	=>	=>	=>	=>	.71
L 11 AMPLIFIER	.19	.09	.06	.04	=>	=>	=>	=>	=>	.04
TOTALS	10.25	7.53	6.95	6.00	=>	=>	=>	=>	=>	6.00
Probability (15% NFMC	.091	.286	.332	.342	=>	=>	=>	=>	=>	.342
Probability Achieve Sorties	.958	.999	=>	=>	=>	=>	=>	=>	=>	.999
FMC- 85% CONF.	9	11	=>	=>	=>	=>	=>	=>	=>	11
E(NFMC)	4.334	3.154	3.024	3.000	2.999	=>	=>	=>	=>	2.999
EXP. % NFMC	.289	.210	.202	.200	=>	=>	=>	=>	=>	.200
E(SORTIES) EXP.	14.91	15.00	=>	=>	=>	=>	=>	=>	=>	15.00
SORTIES / ACFT	1.326	1.268	1.256	1.254	=>	=>	=>	=>	=>	1.254

TABLE XXI

Wartime Scenario Baseline

(Expected Base AWP Quantity / Performance)

Day	1	15	30	90	150	210	270	300	330	365
L 1 BOOM	.89	.89	==)	==)	==)	==)	==)	==)	==)	.89
L 2 NOZZLE	6.40	3.08	1.95	1.42	==)	==)	==)	==)	==)	1.42
L 3 CONTROL	4.49	3.81	3.61	3.54	==)	==)	==)	==)	==)	3.54
L 4 ALTIMETER	2.84	==)	==)	==)	==)	==)	==)	==)	==)	2.84
L 5 ANT APNS9E	.08	==)	==)	==)	==)	==)	==)	==)	==)	.08
L 6 RT APNS9E	1.06	==)	==)	==)	==)	==)	==)	==)	==)	1.06
L 7 COUPLER	.50	==)	==)	==)	==)	==)	==)	==)	==)	.50
L 8 RCVRTAPN69	1.85	==)	==)	==)	==)	==)	==)	==)	==)	1.85
L 9 IND APNS9E	.09	.05	.04	==)	==)	==)	==)	==)	==)	.04
L 10 RT728APX64	1.31	==)	==)	==)	==)	==)	==)	==)	==)	1.31
L 11 AMPLIFIER	.37	.19	.14	.12	==)	==)	==)	==)	==)	.12
TOTALS	13.48	12.58	12.32	12.23	12.23	==)	==)	==)	==)	12.23
Probability (15% NFMC	.464	.506	.507	==)	==)	==)	==)	==)	==)	.507
Probability Achieve Sorties	.717	.752	.753	==)	==)	==)	==)	==)	==)	.753
FMC- 85% CONF.	11	11	11	==)	==)	==)	==)	==)	==)	11
E(NFMC)	2.796	2.635	2.631	2.630	==)	==)	==)	==)	==)	2.630
EXP. % NFMC	.186	.176	.175	==)	==)	==)	==)	==)	==)	.175
E(SORTIES) EXP.	28.79	28.99	28.99	==)	==)	==)	==)	==)	==)	28.99
SORTIES / ACFT	1.742	1.745	1.746	==)	==)	==)	==)	==)	==)	1.746

TABLE XXII

25% Reduction DSF - Wartime Scenario

(Expected Base AWP Quantity / Performance)

Day	1	15	30	90	150	210	270	300	330	365
L 1 BOOM	.82	==)	==)	==)	==)	==)	==)	==)	==)	.82
L 2 NOZZLE	6.98	3.59	2.39	1.82	1.81	==)	==)	==)	==)	1.81
L 3 CONTROL	4.49	3.81	3.61	3.54	==)	==)	==)	==)	==)	3.54
L 4 ALTIMETER	2.79	==)	==)	==)	==)	==)	==)	==)	==)	2.79
L 5 ANT APN59E	.08	==)	==)	==)	==)	==)	==)	==)	==)	.08
L 6 RT APN59E	1.04	==)	==)	==)	==)	==)	==)	==)	==)	1.04
L 7 COUPLER	.47	==)	==)	==)	==)	==)	==)	==)	==)	.47
L 8 RCVRTAPN69	1.83	==)	==)	==)	==)	==)	==)	==)	==)	1.83
L 9 IND APN59E	.09	.05	==)	.04	.04	==)	==)	==)	==)	.04
L 10 RT720APX64	1.29	==)	==)	==)	==)	==)	==)	==)	==)	1.29
L 11 AMPLIFIER	.34	.17	.12	.10	==)	==)	==)	==)	==)	.10
TOTALS	20.22	15.94	14.48	13.82	13.81	==)	==)	==)	==)	13.81
Probability (15% NFMC	.451	.520	.523	==)	==)	==)	==)	==)	==)	.523
Probability Achieve Sorties	.701	.763	.765	==)	==)	==)	==)	==)	==)	.765
FMC- 85% CONF.	11	11	11	==)	==)	==)	==)	==)	==)	11
E(NFMC)	2.871	2.588	2.577	2.576	==)	==)	==)	==)	==)	2.576
EXP. % NFMC	.191	.173	.172	==)	==)	==)	==)	==)	==)	.172
E(SORTIES) EXP.	28.66	29.04	29.05	==)	==)	==)	==)	==)	==)	29.05
SORTIES / ACFT	1.753	1.748	1.750	==)	==)	==)	==)	==)	==)	1.750

TABLE XXIII

50% Reduction DSF - Wartime Scenario

(Expected Base AWP Quantity / Performance)

Day	1	15	30	90	150	210	270	300	330	365
L 1 BOOM	.76	=>	=>	=>	=>	=>	=>	=>	=>	.76
L 2 NOZZLE	6.00	2.82	1.73	1.24	1.23	=>	=>	=>	=>	1.23
L 3 CONTROL	4.49	3.81	3.61	3.54	=>	=>	=>	=>	=>	3.54
L 4 ALTIMETER	2.77	=>	=>	=>	=>	=>	=>	=>	=>	2.77
L 5 ANT APN59E	.07	=>	=>	=>	=>	=>	=>	=>	=>	.07
L 6 RT APN59E	1.02	=>	=>	=>	=>	=>	=>	=>	=>	1.02
L 7 COUPLER	.44	=>	=>	=>	=>	=>	=>	=>	=>	.44
L 8 RCVRTAPN69	1.81	=>	=>	=>	=>	=>	=>	=>	=>	1.81
L 9 IND APN59E	.09	.05	.04	=>	=>	=>	=>	=>	=>	.04
L 10 RT728APX64	1.26	=>	=>	=>	=>	=>	=>	=>	=>	1.26
L 11 AMPLIFIER	.30	.15	.11	.09	=>	=>	=>	=>	=>	.09
TOTALS	19.09	14.96	13.62	13.04	13.03	=>	=>	=>	=>	13.03
Probability (15% NFMC	.497	.539	.540	.540	=>	=>	=>	=>	=>	.540
Probability Achieve Sorties	.743	.776	.777	=>	=>	=>	=>	=>	=>	.777
FMC- 85% CONF.	11	11	11	=>	=>	=>	=>	=>	=>	11
S(NFMC)	2.602	2.525	2.521	2.520	=>	=>	=>	=>	=>	2.520
EXP. % NFMC	.179	.168	.168	=>	=>	=>	=>	=>	=>	.168
E(SORTIES) EXP.	28.92	29.10	29.10	=>	=>	=>	=>	=>	=>	29.10
SORTIES / ACFT	1.740	1.754	1.755	=>	=>	=>	=>	=>	=>	1.755

TABLE XXIV

75% Reduction DSF - Wartime Scenario

(Expected Base AWP Quantity / Performance)

Day	1	15	30	90	150	210	270	300	330	365
L 1 BOOM	.71	==)	==)	==)	==)	==)	==)	==)	==)	.71
L 2 NOZZLE	5.20	2.11	1.18	.78	.77	==)	==)	==)	==)	.77
L 3 CONTROL	4.49	3.81	3.61	3.54	==)	==)	==)	==)	==)	3.54
L 4 ALTIMETER	2.73	==)	==)	==)	==)	==)	==)	==)	==)	2.73
L 5 ANT APN59E	.07	==)	==)	==)	==)	==)	==)	==)	==)	.07
L 6 RT APN59E	1.00	==)	==)	==)	==)	==)	==)	==)	==)	1.00
L 7 COUPLER	.41	==)	==)	==)	==)	==)	==)	==)	==)	.41
L 8 RCVRTAPN69	1.79	==)	==)	==)	==)	==)	==)	==)	==)	1.79
L 9 IND APN59E	.09	.05	.04	==)	==)	==)	==)	==)	==)	.04
L 10 RT728APX64	1.23	==)	==)	==)	==)	==)	==)	==)	==)	1.23
L 11 AMPLIFIER	.27	.13	.10	.08	==)	==)	==)	==)	==)	.08
TOTALS	17.99	14.04	12.87	12.38	12.37	==)	==)	==)	==)	12.37
Probability (15% NFMC	.529	.551	.552	==)	==)	==)	==)	==)	==)	.552
Probability Achieve Sorties	.770	.785	==)	==)	==)	==)	==)	==)	==)	.785
FMC- 85% CONF.	11	11	==)	==)	==)	==)	==)	==)	==)	11
E(NFMC)	2.560	2.482	2.480	==)	==)	==)	==)	==)	==)	2.480
EXP. % NFMC	.171	.165	==)	==)	==)	==)	==)	==)	==)	.165
E(SORTIES) EXP.	29.07	29.14	==)	==)	==)	==)	==)	==)	==)	29.14
SORTIES / ACFT	1.751	1.759	==)	==)	==)	==)	==)	==)	==)	1.759

TABLE XXV

25% Reduction RIT - Wartime Scenario

(Expected Base AWP Quantity / Performance)

Day	1	15	30	90	150	210	270	300	330	365
L 1 BOOM	.86	=)	=)	=)	=)	=)	=)	=)	=)	.86
L 2 NOZZLE	6.00	2.74	1.67	1.18	=)	=)	=)	=)	=)	1.18
L 3 CONTROL	4.49	3.81	3.61	3.54	=)	=)	=)	=)	=)	3.54
L 4 ALTIMETER	2.76	=)	=)	=)	=)	=)	=)	=)	=)	2.76
L 5 ANT APNS9E	.07	=)	=)	=)	=)	=)	=)	=)	=)	.07
L 6 RT APNS9E	1.00	=)	=)	=)	=)	=)	=)	=)	=)	1.00
L 7 COUPLER	.45	=)	=)	=)	=)	=)	=)	=)	=)	.45
L 8 RCVRTAPN69	1.82	=)	=)	=)	=)	=)	=)	=)	=)	1.82
L 9 IND APNS9E	.09	.05	.04	=)	=)	=)	=)	=)	=)	.04
L 10 RT728APX64	1.23	=)	=)	=)	=)	=)	=)	=)	=)	1.23
L 11 AMPLIFIER	.31	.16	.11	.09	=)	=)	=)	=)	=)	.09
TOTALS	19.08	14.95	13.62	13.04	=)	=)	=)	=)	=)	13.04
Probability (15% NFMC	.487	.520	.521	=)	=)	=)	=)	=)	=)	.521
Probability Achieve Sorties	.737	.763	=)	=)	=)	=)	=)	=)	=)	.763
FMC- 85% CONF.	11	11	=)	=)	=)	=)	=)	=)	=)	11
E(NFMC)	2.706	2.585	=)	2.582	=)	=)	=)	=)	=)	2.582
EXP. % NFMC	.180	.172	=)	=)	=)	=)	=)	=)	=)	.172
E(SORTIES) EXP.	28.91	29.04	=)	=)	=)	=)	=)	=)	=)	29.04
SORTIES / ACFT	1.742	1.748	1.749	=)	=)	=)	=)	=)	=)	1.749

TABLE XXVI

50% Reduction RIT - Wartime Scenario

(Expected Base AWP Quantity / Performance)

Day	1	15	30	90	150	210	270	300	330	365
L 1 BOOM	.83	==)	==)	==)	==)	==)	==)	==)	==)	.83
L 2 NOZZLE	6.98	3.59	2.39	1.82	1.81	==)	==)	==)	==)	1.81
L 3 CONTROL	4.49	3.81	3.61	3.54	==)	==)	==)	==)	==)	3.54
L 4 ALTIMETER	2.68	==)	==)	==)	==)	==)	==)	==)	==)	2.68
L 5 ANT APNS9E	.87	==)	==)	==)	==)	==)	==)	==)	==)	.87
L 6 RT APNS9E	.95	==)	==)	==)	==)	==)	==)	==)	==)	.95
L 7 COUPLER	.39	==)	==)	==)	==)	==)	==)	==)	==)	.39
L 8 RCVRTAPN69	1.78	==)	==)	==)	==)	==)	==)	==)	==)	1.78
L 9 IND APNS9E	.88	.85	.84	==)	==)	==)	==)	==)	==)	.84
L 10 RT728APX64	1.14	==)	==)	==)	==)	==)	==)	==)	==)	1.14
L 11 AMPLIFIER	.25	.12	.89	.87	==)	==)	==)	==)	==)	.87
TOTALS	19.64	15.41	13.97	13.31	13.30	==)	==)	==)	==)	13.30
Probability (15% NFMC	.461	.531	.535	.535	==)	==)	==)	==)	==)	.535
Probability Achieve Sorties	.710	.772	.774	.774	==)	==)	==)	==)	==)	.774
FMC- 85% CONF.	11	11	11	11	==)	==)	==)	==)	==)	11
E(NFMC)	2.833	2.546	2.535	2.533	==)	==)	==)	==)	==)	2.533
EXP. % NFMC	.189	.170	.169	.169	==)	==)	==)	==)	==)	.169
E(SORTIES) EXP.	28.70	29.09	29.10	29.10	==)	==)	==)	==)	==)	29.10
SORTIES / ACFT	1.753	1.749	1.751	1.751	==)	==)	==)	==)	==)	1.751

TABLE XXVII

75% Reduction RIT - Wartime Scenario

(Expected Base AWP Quantity / Performance)

Day	1	15	30	90	150	210	270	300	330	365
L 1 BOOM	.80	==)	==)	==)	==)	==)	==)	==)	==)	.80
L 2 NOZZLE	6.54	3.20	2.06	1.52	1.51	==)	==)	==)	==)	1.51
L 3 CONTROL	4.49	3.81	3.61	3.54	==)	==)	==)	==)	==)	3.54
L 4 ALTIMETER	2.60	==)	==)	==)	==)	==)	==)	==)	==)	2.60
L 5 ANT APNS9E	.07	==)	==)	==)	==)	==)	==)	==)	==)	.07
L 6 RT APNS9E	.89	==)	==)	==)	==)	==)	==)	==)	==)	.89
L 7 COUPLER	.34	==)	==)	==)	==)	==)	==)	==)	==)	.34
L 8 RCVRTAPN69	1.74	==)	==)	==)	==)	==)	==)	==)	==)	1.74
L 9 IND APNS9E	.07	.05	.04	==)	==)	==)	==)	==)	==)	.04
L 10 RT728APX64	1.06	==)	==)	==)	==)	==)	==)	==)	==)	1.06
L 11 AMPLIFIER	.20	.09	.06	.05	==)	==)	==)	==)	==)	.05
TOTALS	18.00	14.65	13.27	12.68	12.64	==)	==)	==)	==)	12.64
Probability (15% NFMC	.490	.547	.549	==)	==)	==)	==)	==)	==)	.549
Probability Achieve Sorties	.737	.784	.785	==)	==)	==)	==)	==)	==)	.785
FMC- 85% CONF.	11	11	11	==)	==)	==)	==)	==)	==)	11
E(NFMC)	2.713	2.492	2.486	2.485	==)	==)	==)	==)	==)	2.485
EXP. % NFMC	.181	.166	==)	==)	==)	==)	==)	==)	==)	.166
E(SORTIES) EXP.	28.87	29.14	29.15	==)	==)	==)	==)	==)	==)	29.15
SORTIES / ACFT	1.750	1.753	1.755	==)	==)	==)	==)	==)	==)	1.755

TABLE XXVIII

25% Reduction SMX - Wartiar Scenario

(Expected Base AWP Quantity / Performance)

Day	1	15	30	90	150	210	270	300	330	365
L 1 BOOM	.86	==)	==)	==)	==)	==)	==)	==)	==)	.86
L 2 NOZZLE	6.40	3.08	1.95	1.42	==)	==)	==)	==)	==)	1.42
L 3 CONTROL	4.49	3.81	3.61	3.54	==)	==)	==)	==)	==)	3.54
L 4 ALTIMETER	2.77	==)	==)	==)	==)	==)	==)	==)	==)	2.77
L 5 ANT APN59E	.07	==)	==)	==)	==)	==)	==)	==)	==)	.07
L 6 RT APN59E	1.02	==)	==)	==)	==)	==)	==)	==)	==)	1.02
L 7 COUPLER	.46	==)	==)	==)	==)	==)	==)	==)	==)	.46
L 8 RCVRTAPN69	1.81	==)	==)	==)	==)	==)	==)	==)	==)	1.81
L 9 IND APN59E	.09	.05	.04	==)	==)	==)	==)	==)	==)	.04
L 10 RT728APX64	1.25	==)	==)	==)	==)	==)	==)	==)	==)	1.25
L 11 AMPLIFIER	.35	.18	.13	.11	==)	==)	==)	==)	==)	.11
TOTALS	19.57	15.36	13.97	13.35	==)	==)	==)	==)	==)	13.35
Probability (15% NFMC)	.475	.518	.520	==)	==)	==)	==)	==)	==)	.520
Probability Achieve Sorties	.726	.762	==)	==)	==)	==)	==)	==)	==)	.762
FMC- 85% CONF.	11.	==)	==)	==)	==)	==)	==)	==)	==)	11.
E(NFMC)	2.756	2.591	2.587	2.586	==)	==)	==)	==)	==)	2.586
EXP. % NFMC	.184	.173	.172	==)	==)	==)	==)	==)	==)	.172
E(SORTIES) EXP.	28.84	29.04	==)	==)	==)	==)	==)	==)	==)	29.04
SORTIES / ACFT	1.743	1.748	1.749	==)	==)	==)	==)	==)	==)	1.749

TABLE XXIX

50% Reduction SMX - Wartime Scenario

(Expected Base AWP Quantity / Performance)

Day	:	15	30	90	150	210	270	300	330	365
L 1	BOOM	.82	=>	=>	=>	=>	=>	=>	=>	.82
L 2	NOZZLE	6.40	3.08	1.95	1.42	=>	=>	=>	=>	1.42
L 3	CONTROL	4.49	3.81	3.61	3.54	=>	=>	=>	=>	3.54
L 4	ALTIMETER	2.70	=>	=>	=>	=>	=>	=>	=>	2.70
L 5	ANT APN59E	.87	=>	=>	=>	=>	=>	=>	=>	.87
L 6	RT APN59E	.98	=>	=>	=>	=>	=>	=>	=>	.98
L 7	COUPLER	.42	=>	=>	=>	=>	=>	=>	=>	.42
L 8	RCVRTAPN69	1.77	=>	=>	=>	=>	=>	=>	=>	1.77
L 9	IND APN59E	.88	.85	.84	=>	=>	=>	=>	=>	.84
L 10	RT728APX64	1.25	=>	=>	=>	=>	=>	=>	=>	1.25
L 11	AMPLIFIER	.29	.14	.10	.88	=>	=>	=>	=>	.88
	TOTALS	19.24	15.06	13.68	13.06	13.06	=>	=>	=>	13.06
	Probability (15% NFMC)	.487	.531	.532	=>	=>	=>	=>	=>	.532
	Probability Achieve Sorties	.736	.771	.772	=>	=>	=>	=>	=>	.772
	FMC- 85% CONF.	11.	11.	11.	=>	=>	=>	=>	=>	11.
	E(NFMC)	2.715	2.548	2.543	=>	=>	=>	=>	=>	2.543
	EXP. % NFMC	.181	.170	.170	=>	=>	=>	=>	=>	.170
	E(SORTIES) EXP.	28.88	29.08	29.08	=>	=>	=>	=>	=>	29.08
	SORTIES / ACFT	1.745	1.751	1.751	1.752	=>	=>	=>	=>	1.752

TABLE XXX

75% Reduction SMX - Wartime Scenario

(Expected Base AWP Quantity / Performance)

Day	1	15	30	90	150	210	270	300	330	365
L 1 BOOM	.79	==)	==)	==)	==)	==)	==)	==)	==)	.79
L 2 NOZZLE	6.40	3.08	1.95	1.42	==)	==)	==)	==)	==)	1.42
L 3 CONTROL	4.49	3.81	3.61	3.54	==)	==)	==)	==)	==)	3.54
L 4 ALTIMETER	2.63	==)	==)	==)	==)	==)	==)	==)	==)	2.63
L 5 ANT APN59E	.07	==)	==)	==)	==)	==)	==)	==)	==)	.07
L 6 RT APN59E	.94	==)	==)	==)	==)	==)	==)	==)	==)	.94
L 7 COUPLER	.39	==)	==)	==)	==)	==)	==)	==)	==)	.39
L 8 RCVRTAPN69	1.73	==)	==)	==)	==)	==)	==)	==)	==)	1.73
L 9 IND APN59E	.08	.05	.04	==)	==)	==)	==)	==)	==)	.04
L 10 RT728APX64	1.12	==)	==)	==)	==)	==)	==)	==)	==)	1.12
L 11 AMPLIFIER	.25	.12	.09	.07	==)	==)	==)	==)	==)	.07
TOTALS	18.89	14.73	13.36	12.74	==)	==)	==)	==)	==)	12.74
Probability (15% NFMC	.499	.544	.545	==)	==)	==)	==)	==)	==)	.545
Probability Achieve Sorties	.745	.781	.782	==)	==)	==)	==)	==)	==)	.782
FMC- 85% CONF.	11.	11.	11.	==)	==)	==)	==)	==)	==)	11.
E(NFMC)	2.675	2.504	2.500	2.499	==)	==)	==)	==)	==)	2.499
EXP. % NFMC	.178	.167	.167	==)	==)	==)	==)	==)	==)	.167
E(SORTIES) EXP.	28.93	29.13	29.13	==)	==)	==)	==)	==)	==)	29.13
SORTIES / ACFT	1.748	1.754	1.755	==)	==)	==)	==)	==)	==)	1.755

TABLE XXXI

25% Reduction TRN - Wartime Scenario

(Expected Base AWP Quantity / Performance)

Day	1	15	30	90	150	210	270	300	330	365
1 BOOM	.88	.88	=>	=>	=>	=>	=>	=>	=>	.88
2 NOZZLE	6.00	2.74	1.67	1.18	=>	=>	=>	=>	=>	1.18
3 CONTROL	4.49	3.81	3.61	3.84	=>	=>	=>	=>	=>	3.84
4 ALTIMETER	2.83	=>	=>	=>	=>	=>	=>	=>	=>	2.83
5 ANT APN59E	.88	=>	=>	=>	=>	=>	=>	=>	=>	.88
6 RT APN59E	1.85	=>	=>	=>	=>	=>	=>	=>	=>	1.85
7 COUPLER	.49	=>	=>	=>	=>	=>	=>	=>	=>	.49
8 RCVRTAPN69	1.85	=>	=>	=>	=>	=>	=>	=>	=>	1.85
9 IND APN59E	.89	.85	.84	=>	=>	=>	=>	=>	=>	.84
10 RT728APX64	1.30	=>	=>	=>	=>	=>	=>	=>	=>	1.30
11 AMPLIFIER	.36	.19	.14	.11	=>	=>	=>	=>	=>	.11
TOTALS	19.42	15.27	13.94	13.35	=>	=>	=>	=>	=>	13.35
Probability (15% NFMC	.477	.509	.510	=>	=>	=>	=>	=>	=>	.510
Probability Achieve Sorties	.729	.754	.755	=>	=>	=>	=>	=>	=>	.755
FMC- 85% CONF.	11.	11.	11.	=>	=>	=>	=>	=>	=>	11.
E(NFMC)	2.744	2.624	2.622	2.621	=>	=>	=>	=>	=>	2.621
EXP. % NFMC	.183	.175	=>	=>	=>	=>	=>	=>	=>	.175
E(SORTIES) EXP.	28.86	29.00	=>	=>	=>	=>	=>	=>	=>	29.00
SORTIES / ACFT	1.741	1.746	1.747	=>	=>	=>	=>	=>	=>	1.747

TABLE XXXII

50% Reduction TRN - Wartime Scenario

(Expected Base AWP Quantity / Performance)

Day	1	15	30	90	150	210	270	300	330	365
L 1 BOOM	.86	==)	==)	==)	==)	==)	==)	==)	==)	.88
L 2 NOZZLE	6.00	2.74	1.67	1.18	==)	==)	==)	==)	==)	1.18
L 3 CONTROL	4.49	3.81	3.61	3.54	==)	==)	==)	==)	==)	3.54
L 4 ALTIMETER	2.81	==)	==)	==)	==)	==)	==)	==)	==)	2.81
L 5 ANT APN59E	.08	==)	==)	==)	==)	==)	==)	==)	==)	.08
L 6 RT APN59E	1.04	==)	==)	==)	==)	==)	==)	==)	==)	1.04
L 7 COUPLER	.49	==)	==)	==)	==)	==)	==)	==)	==)	.49
L 8 RCVRTAPN69	1.84	==)	==)	==)	==)	==)	==)	==)	==)	1.84
L 9 IND APN59E	.09	.05	.04	==)	==)	==)	==)	==)	==)	.04
L 10 RT728APX64	1.29	==)	==)	==)	==)	==)	==)	==)	==)	1.29
L 11 AMPLIFIER	.35	.18	.13	.11	==)	==)	==)	==)	==)	.11
TOTALS	19.36	15.21	13.88	13.35	==)	==)	==)	==)	==)	13.35
Probability (15% NFMC	.479	.512	==)	==)	==)	==)	==)	==)	==)	.512
Probability Achieve Sorties	.731	.756	.757	==)	==)	==)	==)	==)	==)	.757
FMC- 85% CONF.	11.	11.	11.	==)	==)	==)	==)	==)	==)	11.
E(NFMC)	2.736	2.615	2.613	2.612	==)	==)	==)	==)	==)	2.612
EXP. % NFMC	.182	.174	==)	==)	==)	==)	==)	==)	==)	.174
E(SORTIES) EXP.	28.87	29.01	==)	==)	==)	==)	==)	==)	==)	29.01
SORTIES / ACFT	1.741	1.747	==)	==)	==)	==)	==)	==)	==)	1.747

TABLE XXXIII

75% Reduction TRN - Wartime Scenario

(Expected Base AWP Quantity / Performance)

Day	1	15	30	90	150	210	270	300	330	365
L 1 BOOM	.87	==>	==>	==>	==>	==>	==>	==>	==>	.87
L 2 NOZZLE	6.54	3.20	2.06	1.52	1.51	==>	==>	==>	==>	1.51
L 3 CONTROL	4.49	3.81	3.61	3.54	==>	==>	==>	==>	==>	3.54
L 4 ALTIMETER	2.80	==>	==>	==>	==>	==>	==>	==>	==>	2.80
L 5 ANT APN59E	.08	==>	==>	==>	==>	==>	==>	==>	==>	.08
L 6 RT APN59E	1.04	==>	==>	==>	==>	==>	==>	==>	==>	1.04
L 7 COUPLER	.48	==>	==>	==>	==>	==>	==>	==>	==>	.48
L 8 RCVRTAPN69	1.83	==>	==>	==>	==>	==>	==>	==>	==>	1.83
L 9 IND APN59E	.09	.05	.04	==>	==>	==>	==>	==>	==>	.04
L 10 RT728APX64	1.270	==>	==>	==>	==>	==>	==>	==>	==>	1.270
L 11 AMPLIFIER	.35	.18	.13	.11	.10	==>	==>	==>	==>	.10
TOTALS	19.84	15.61	14.21	13.58	13.56	==>	==>	==>	==>	13.56
Probability (15% NFMC	.460	.513	.515	==>	==>	==>	==>	==>	==>	.515
Probability Achieve Sorties	.712	.757	.758	==>	==>	==>	==>	==>	==>	.758
FMC- 85% CONF.	11.	11.	11.	==>	==>	==>	==>	==>	==>	11.
E(NFMC)	2.820	2.611	2.605	2.604	==>	==>	==>	==>	==>	2.604
EXP. % NFMC	.188	.174	.174	==>	==>	==>	==>	==>	==>	.174
E(SORTIES) EXP.	28.75	29.01	29.02	==>	==>	==>	==>	==>	==>	29.02
SORTIES / ACFT	1.746	1.746	1.748	==>	==>	==>	==>	==>	==>	1.748

Bibliography

1. Air Force Logistics Management Center. "User's Guide Dyna-METRIC." Draft Report. Gunter AFS AL, June 1982.
2. Aninno, Joseph S. and Edward C. Russel. "The Seven Most Frequent Causes of Simulation Failure--And How to Avoid Them," Interfaces, 11 (3): 59-63.
3. Banks, Jerry and John S. Carson. Discrete-Event System Simulation. Englewood Cliffs NJ: Prentice-Hall Inc., 1984.
4. Demmy, W.S. and Jon R. Hobbs. "Dyna-METRIC: An Overview," Air Force Journal of Logistics, 7 (2): 14-17 (Spring 1983).
5. ----- and V.J. Presutti. "Multi-Echelon Inventory Theory in the Air Force Logistics Command," Chapter 13 in Multi-Level Production/Inventory/Control. L.B. Schwartz (Ed.), North-Holland, Amsterdam: Timms Press, 1981.
6. Department of the Air Force. USAF Standard Base Supply System. AFM 67-1, Vol 2. Washington, HQ USAF, 1 October 1982.
7. ----- . Maintenance Material Control. AFLCR 66-53. Wright-Patterson AFB OH, HQ AFLC, 27 December 1977.
8. ----- . Recoverable Consumption Item Requirements System (DO41). AFLCR 57-4. Wright-Patterson AFB OH, HQ AFLC, 29 April 1983.
9. Gage, Thomas W., and Captain Andrew J. Ogan. "Dyna-Metric: A Valuable Management Tool," Air Force Journal of Logistics, 7 (2): 22-24 (Spring 1983).
10. Hillestad, R.J. Dyna-METRIC: Multi-Echelon Technique for Recoverable Item Control. Report Number R-2785-AF. The Rand Corporation, Santa Monica CA, July 1982.
11. ----- and M.J. Carillo. Models and Techniques for Recoverable Item Stockage When Demand and the Repair Process are Nonstationary -- Part 1: Performance Measurement. A Rand Note, N-1482-AF. The Rand Corporation, Santa Monica CA, May 1980.
12. Isaacson, Karen E. and others. DYNA-METRIC Version 4: Modeling Worldwide Logistics Support to Aircraft Components. Working Draft Number WD-2659-AF. The Rand Corporation, Santa Monica CA, June 1985.

13. Lindsey, Major Gene. Air Force Logistics Management Center. Telephone Interview. Gunter AFS AL, 8 January 1985.
14. Mabe, Richard D. and Robert E. Oraston. A Dyna-METRIC Analysis of Supply Support for Mobile Tactical Radar Units in Europe. MS thesis, LSM 84S-43. School of Systems and Logistics, Air Force Institute of Technology (AU), Wright-Patterson AFB OH, September 1984 (AD-A147 286).
15. Muckstadt, John A. "A Model for a Multi-Item, Multi-Echelon, Multi-Indenture Inventory," Management Science. 20 (4): 472-481 (December 1973).
16. Pyles, Raymond. The Dyna-METRIC Readiness Assessment Model: Motivation, and Uses. WD-892-AF, The Rand Corporation, Santa Monica CA, February 1982.
17. School of Systems and Logistics. Compendium of Authenticated Systems and Logistics Terms, Definitions, and Acronyms. Air Force Institute of Technology (AU), Wright-Patterson AFB OH, 1981.
18. Shannon, Robert E. Systems Simulation: The Art and Science. Englewood Cliffs NJ: Prentice-Hall Inc., 1975.
19. Sherbrooke, Craig C. "METRIC: A Multi-Echelon Technique for Recoverable Item Control," Operations Research, 16 (1): 122-141 (1968).
20. Thirty-four hundredth Technical Training Wing. Material Support and Material Control. Study Guide for 6421 Supply Operations Officer Course. 3400th Technical Training Group, Lowry AFB CO, September 1983.

VITA

Major Lewis E. Huber was born 24 February 1950 in Dayton, Ohio. He graduated from Ohio University in August 1972 with a Bachelor of Science degree in Industrial Technology. Upon graduation, he received a commission in the USAF through the ROTC program. In January 1983 he was called to active duty, entering Undergraduate Navigator Training (UNT) at Mather AFB CA. After completion of UNT, he was assigned to the 16th Special Operations Squadron, Ubon RTAFB Thailand. While at Ubon he served as an AC-130A Infrared Operator, Instructor Navigator, and Flight Examiner. In January 1979 he was assigned to the 920th AREFS at Robins AFB GA. Duties at Robins included Training Flight and Standardization-Evaluation Officer. In September 1979, he was assigned to the 379th Bomb Wing, Wurtsmith AFB MI, where he flew KC-135s and served as an Emergency Actions Controller. He received a Master of Science in Industrial Management from Central Michigan University in May 1982. In May 1984 he entered the School of Systems and Logistics, Air Force Institute of Technology.

Major Huber is married to the former Deanna R. Hoffman of Circleville, Ohio. They have two children, Gregory, 9, and Kimberly, 7.

Permanent Address: 11162 Dingess Road
Circleville, Ohio 43113

UNCLASSIFIED

SECURITY CLASSIFICATION OF THIS PAGE

AD-A161570

REPORT DOCUMENTATION PAGE

1a. REPORT SECURITY CLASSIFICATION UNCLASSIFIED		1b. RESTRICTIVE MARKINGS	
2a. SECURITY CLASSIFICATION AUTHORITY		3. DISTRIBUTION/AVAILABILITY OF REPORT Approved for public release; distribution unlimited.	
2b. DECLASSIFICATION/DOWNGRADING SCHEDULE			
4. PERFORMING ORGANIZATION REPORT NUMBER(S) AFIT/GLM/LSM/85S-37		5. MONITORING ORGANIZATION REPORT NUMBER(S)	
6a. NAME OF PERFORMING ORGANIZATION School of Systems and Logistics	6b. OFFICE SYMBOL (If applicable) AFIT/LSM	7a. NAME OF MONITORING ORGANIZATION	
6c. ADDRESS (City, State and ZIP Code) Air Force Institute of Technology Wright-Patterson AFB, Ohio 45433		7b. ADDRESS (City, State and ZIP Code)	
8a. NAME OF FUNDING/SPONSORING ORGANIZATION	8b. OFFICE SYMBOL (If applicable)	9. PROCUREMENT INSTRUMENT IDENTIFICATION NUMBER	
8c. ADDRESS (City, State and ZIP Code)		10. SOURCE OF FUNDING NOS.	
		PROGRAM ELEMENT NO.	PROJECT NO.
		TASK NO.	WORK UNIT NO.
11. TITLE (Include Security Classification) See Box 19			
12. PERSONAL AUTHOR(S) Lewis E. Huber, M.S., Major, USAF			
13a. TYPE OF REPORT MS Thesis	13b. TIME COVERED FROM _____ TO _____	14. DATE OF REPORT (Yr., Mo., Day) 1985 September	15. PAGE COUNT 127
16. SUPPLEMENTARY NOTATION			
17. COSATI CODES		18. SUBJECT TERMS (Continue on reverse if necessary and identify by block number)	
FIELD	GROUP	SUB. GR.	
15	05		
		Supply Depots, Models , Dyna-METRIC Model, Inventory Control Maintenance, Military Supplies	
19. ABSTRACT (Continue on reverse if necessary and identify by block number)			
Title: A DYNA-METRIC ANALYSIS OF BASE AWAITING PARTS (AWP) SENSITIVITY TO REPAIR CYCLE VARIABLES DEPOT			
Thesis Advisor: Richard D. Mabe, Captain, USAF			
Approved for public release: LAW AFB 1804 LYNN E. WOLAVER. 2 Oct 85 Dean for Research and Professional Development Air Force Institute of Technology (MRC) Wright-Patterson AFB OH 45433			
20. DISTRIBUTION/AVAILABILITY OF ABSTRACT UNCLASSIFIED/UNLIMITED <input checked="" type="checkbox"/> SAME AS RPT. <input type="checkbox"/> DTIC USERS <input type="checkbox"/>		21. ABSTRACT SECURITY CLASSIFICATION UNCLASSIFIED	
22a. NAME OF RESPONSIBLE INDIVIDUAL Richadr D. Mabe, Captain, USAF		22b. TELEPHONE NUMBER (Include Area Code) 513-255-5023	22c. OFFICE SYMBOL AFIT/LS

DD FORM 1473, 83 APR

EDITION OF 1 JAN 73 IS OBSOLETE.

UNCLASSIFIED
SECURITY CLASSIFICATION OF THIS PAGE

The efficient operation of the repair/resupply system for Air Force recoverable items is essential for maintaining weapon systems at a viable readiness level. Large AWP inventories at the base level indicate items are remaining unserviceable for long periods of time while awaiting depot supplied spare parts. Dyna-METRIC, the most current inventory model used by the Air Force, is capable of assessing the impact of varying levels of depot support on base AWP and weapon system capability. Dyna-METRIC was used to model eleven KC-135A components and their reparable sub-units, to assess the sensitivity of base AWP to four depot repair cycle variables. The results indicated large improvements in any single depot repair cycle variable was necessary to produce noticeable AWP and capability improvements. Additionally, it was shown the amount of AWP reduction caused by improving a given variable varied among LRUs. Specific recommendations for improving AWP for the 11 KC-135A LRUs, as well as recommendations for further research, are given.

END

FILMED

1-86

DTIC