

MICROCOPY RESOLUTION TEST CHART
NATIONAL BUREAU OF STANDARDS - 1963 - A

12

AD-A161 643

FINAL REPORT PFTR -1109-84-10

Contract No.N00014-81-C-0590

October 15, 1984

MENTAL REPRESENTATION OF CIRCUIT DIAGRAMS

R. Edward Geiselman
Michael G. Samet
Thomas D. Wickens

DTIC
ELECTE
NOV 26 1985
S D

Prepared For:
OFFICE OF NAVAL RESEARCH
800 N. Quincy Street
Arlington, Va 22217

DTIC FILE COPY

DISTRIBUTION STATEMENT A
Approved for public release;
Distribution Unlimited

PERCEPTRONICS

21111 ERWIN STREET • WOODLAND HILLS • CALIFORNIA 91367-3713 • PHONE 818-884-7572

11 20 85 060

FINAL REPORT PFTR -1109-84-10

Contract No. N00014-81-C-0590

October 15, 1984

MENTAL REPRESENTATION OF CIRCUIT DIAGRAMS

R. Edward Geiselman
Michael G. Samet
Thomas D. Wickens

Prepared For:
OFFICE OF NAVAL RESEARCH
800 N. Quincy Street
Arlington, Va 22217

*LOCATIONS OF FIGURES 4-3A
AND 4-3C EXCHANGED BY
ANNOTATION WITH THE PERMISSION
OF DR. HAROLD L. HAWKINS.*

Approved for Release by NSA on 05-08-2013 pursuant to E.O. 13526

PERCEPTRONICS

21111 ERWIN STREET • WOODLAND HILLS • CALIFORNIA 91367-3713 • PHONE 818-884-7572

REPORT DOCUMENTATION PAGE		READ INSTRUCTIONS BEFORE COMPLETING FORM	
1. REPORT NUMBER FINAL REPORT PFTR-1109-84-10	2. GOVT ACCESSION NO. ADA161643	3. RECIPIENT'S CATALOG NUMBER	
4. TITLE (and Subtitle) Mental Representation of Circuit Diagrams		5. TYPE OF REPORT & PERIOD COVERED Final Report	
7. AUTHOR(s) R. Edward Geiselman Michael G. Samet Thomas D. Wickens		6. PERFORMING ORG. REPORT NUMBER PFTR-1109-84-10	
9. PERFORMING ORGANIZATION NAME AND ADDRESS Perceptronics, Inc. 6271 Variel Avenue Woodland Hills, CA 91367		8. CONTRACT OR GRANT NUMBER(s) N00014-81-C-0590	
11. CONTROLLING OFFICE NAME AND ADDRESS Office of Naval Research 800 North Quincy Street Arlington, VA 22217		10. PROGRAM ELEMENT, PROJECT, TASK AREA & WORK UNIT NUMBERS	
14. MONITORING AGENCY NAME & ADDRESS (if different from Controlling Office) Same as Above		12. REPORT DATE October 15, 1984	
		13. NUMBER OF PAGES	
		15. SECURITY CLASS. (of this report) Unclassified	
		15a. DECLASSIFICATION/DOWNGRADING SCHEDULE	
16. DISTRIBUTION STATEMENT (of this Report) Unlimited			
<div style="border: 1px solid black; padding: 5px; display: inline-block;"> This document has been approved for unlimited and sale; its distribution is unlimited. </div>			
17. DISTRIBUTION STATEMENT (of the abstract entered in Block 20, if different from Report)			
18. SUPPLEMENTARY NOTES			
19. KEY WORDS (Continue on reverse side if necessary and identify by block number)			
circuit diagrams functional knowledge structural knowledge cognitive models individual differences symbolic knowledge electronic circuits knowledge representation procedural knowledge expert systems mental representation procedural guidelines			
20. ABSTRACT (Continue on reverse side if necessary and identify by block number)			
This work is concerned with the knowledge that electronics technicians possess of electronic equipment, and more generally, with how people operate in tasks that draw upon a complex spatial symbolic knowledge base. A technician's knowledge base is postulated to consist of three types of related knowledge: (a) structural/functional knowledge, which pertains to the actual configuration of a circuit and the role that its components play in the operation of the device; (b) prototypical knowledge, which pertains to the			

#20 - Abstract (cont'd)

general properties common to circuits of a given type; and (c) procedural knowledge, which pertains to the way that a circuit can be modified and to the interaction among knowledge elements of all three types of knowledge. Early phases of this work focused on a study of individual differences in structural knowledge and an experiment conducted to investigate individual differences in procedural knowledge. Novice and expert subjects performed tasks in which they had to either locate and correct an error in a circuit, change the function of a circuit, or complete a missing segment in a circuit. On all tasks, experts were found to be far more accurate than novices; but more important, experts were classified -- on the basis of verbal protocols -- to be considerably more systematic, orderly, and directed in their problem solving strategies. The productive procedures used by experts were then translated into specific guidelines toward improving circuit comprehension and troubleshooting, and the effectiveness of these guidelines were evaluated in a subsequent experiment. The results of this research program should help in providing guidelines for training electronic techniques to better understand and troubleshoot complex equipment.

TABLE OF CONTENTS

	<u>Page</u>
ABSTRACT	111
1. INTRODUCTION	1-1
1.1 Summary	1-1
1.2 Program Overview	1-2
1.2.1 Objectives	1-3
2. RESEARCH BACKGROUND	2-1
2.1 Overview	2-1
2.2 Knowledge Base and Complex Problem Solving	2-2
2.3 Nature of the Mental Representation	2-4
2.4 Comparing Novices to Experts	2-6
2.5 Theoretical Perspective	2-8
3. REVIEW OF FIRST-YEAR WORK: INVESTIGATION OF STRUCTURAL/ FUNCTIONAL KNOWLEDGE	3-1
3.1 Overview	3-1
4. REVIEW OF SECOND-YEAR WORK: INVESTIGATION OF PROCEDURAL KNOWLEDGE	4-1
4.1 Overview	4-1
4.2 Task 1: Error Correction ("FIX" Task)	4-2
4.3 Task 2: Change Function ("ALTER" Task)	4-2
4.4 Task 3: Complete Circuit ("COMPLETE" Task)	4-2
4.5 Subjects	4-3
4.6 Materials	4-3
4.7 General Procedure	4-3
4.8 Results	4-24
4.8.1 Accuracy of Solutions	4-24
4.8.2 Classification of Protocols	4-24
4.8.3 Solution Time	4-30
4.8.4 Content Differences	4-30
4.9 Conclusions	4-31

Accession For			
NTIS	CRA&I	<input checked="" type="checkbox"/>	4-30
DTIC	TAB	<input type="checkbox"/>	4-30
Unannounced		<input type="checkbox"/>	
Justification			
By			
Distribution /			
Availability Codes			
Dist	Avail and/or Special		
A-1			



TABLE OF CONTENTS (Cont'd)

	<u>Page</u>
5. REVIEW OF THIRD YEAR WORK: DERIVATION AND VALIDATION OF PROCEDURAL GUIDELINES	5-1
5.1 Overview	5-1
5.2 Procedural Guidelines	5-2
5.3 Subjects	5-4
5.4 Materials	5-5
5.5 Design and Procedure	5-5
5.6 Results	5-9
5.6.1 Accuracy of Solutions	5-9
5.6.2 Classification of Protocols	5-12
5.6.3 Solution Time	5-15
5.7 Conclusions	5-15
6. GENERAL CONCLUSIONS	6-1
7. REFERENCES	7-1

ABSTRACT

This work is concerned with the knowledge that electronics technicians possess of electronic equipment, and more generally, with how people operate in tasks that draw upon a complex spatial symbolic knowledge base. A technician's knowledge base is postulated to consist of three types of related knowledge: (a) structural/functional knowledge, which pertains to the actual configuration of a circuit and the role that its components play in the operation of the device; (b) prototypical knowledge, which pertains to the general properties common to circuits of a given type; and (c) procedural knowledge, which pertains to the way that a circuit can be modified and to the interaction among knowledge elements of all three types of knowledge. Early phases of this work focused on a study of individual differences in structural knowledge and an experiment conducted to investigate individual differences in procedural knowledge. Novice and expert subjects performed tasks in which they had to either locate and correct an error in a circuit, change the function of a circuit, or complete a missing segment in a circuit. On all tasks, experts were found to be far more accurate than novices; but more important, experts were classified -- on the basis of verbal protocols -- to be considerably more systematic, orderly, and directed in their problem solving strategies. The productive procedures used by experts were then translated into specific guidelines toward improving circuit comprehension and troubleshooting, and the effectiveness of these guidelines were evaluated in a subsequent experiment. The results of this research program should help in providing guidelines for training electronic techniques to better understand and troubleshoot complex equipment.

1. INTRODUCTION

1.1 Summary

This report describes a three-year program of research devoted to understanding the knowledge base required by experienced technicians to troubleshoot complex electronic equipment. The primary objectives of this program were to (1) describe the mental representations of electronic devices that technicians derive from schematic circuit diagrams, and (2) characterize the ways in which technicians apply these mental representations to trouble-shooting and problem solving. In the first year, we largely accomplished the first objective with a macro-experiment designed to assess the structural/functional knowledge of electronic devices possessed by technicians varying in skill level. Observed performance differences included errors in characteristic places in the circuits and global differences in the structure and organization of the knowledge base.

It was our view that these differences, which primarily reflect knowledge of facts about the circuit, were not sufficient to explain the variations in skill between technicians, nor are these differences the most interesting for investigation. In particular, such differences do not address the way that the circuit knowledge is used. One could train novice technicians on the memorization of circuit diagrams until they made few errors in retention, but they would not become experts through this training. Practical tasks require more than static comprehension of a device. The knowledge base is valuable only to the extent that its holder can operate upon it. It was our hypothesis that the increased proficiency of technicians derived through experience is due to the acquisition of more sophisticated procedural knowledge, not simply to the development of a more complex static knowledge base. Accordingly, in the second year of this

effort, we concentrated on the study of procedural knowledge, with the research information gained during the first year providing the necessary technical background.

The third year of work focused on an integration and summation of the experiments performed during the first two years. This effort included the development and validation of guidelines for comprehension and troubleshooting of circuits. Our premise has been that experts have a mental representation of their area of expertise that is concordant with the information processing requirements that operations on the material entail. This representation can be translated to some extent into guidelines that can be used to improve the performance of other individuals who have, as yet, more limited or otherwise less coherent mental representation of these procedures.

1.2 Program Overview

1.2.1 Objectives. The overall objectives of the program included the following:

- (1) Describe the mental representation of electronic devices that technicians derive from schematic circuit diagrams.
- (2) Characterize the procedural knowledge that technicians apply to the mental representation to perform troubleshooting and problem solving.
- (3) Characterize the knowledge structures and procedures that differentiate among technicians of different skill levels.
- (4) Validate the findings of the descriptive studies by means of hypothetico-deductive experimentation.

Three-Year Program. The research tasks that were conducted during the three-year program were as follows:

- (1) First-Year: Exploration of structural and functional knowledge. Develop stimulus material pool. Perform several studies with electronic technicians varying in skill level to assess the structural/functional knowledge they possess of electronic devices as represented by circuit diagrams.
- (2) Second-Year: Investigation of Procedural Knowledge. Conduct descriptive studies and hypothesis testing experiments to assess the procedural knowledge that is brought to bear on solving problems with circuit diagrams by both novice and more proficient electronics technicians.
- (3) Third-Year: Integration and Summation of Studies Performed During First Two Years. Develop and validate guidelines for comprehending circuits and troubleshooting. This included an experiment suggested by the findings from the first two years.

1.3 Overview of the Technical Approach

An overview of the technical approach for the program is shown in Figure 1-1. Work in the first year began with Task 1, the development of a pool of stimulus circuit diagram materials for use in all of the subsequent work. In Task 2, a macro-experiment was conducted to reveal the structural/functional knowledge possessed by electronic technicians varying in level of expertise. The tasks studied in the first year were a memory task and a component-partitioning task. In the second year, Task 3 investigated the procedural knowledge that technicians apply to the structural/functional representation of electronic circuits. Three

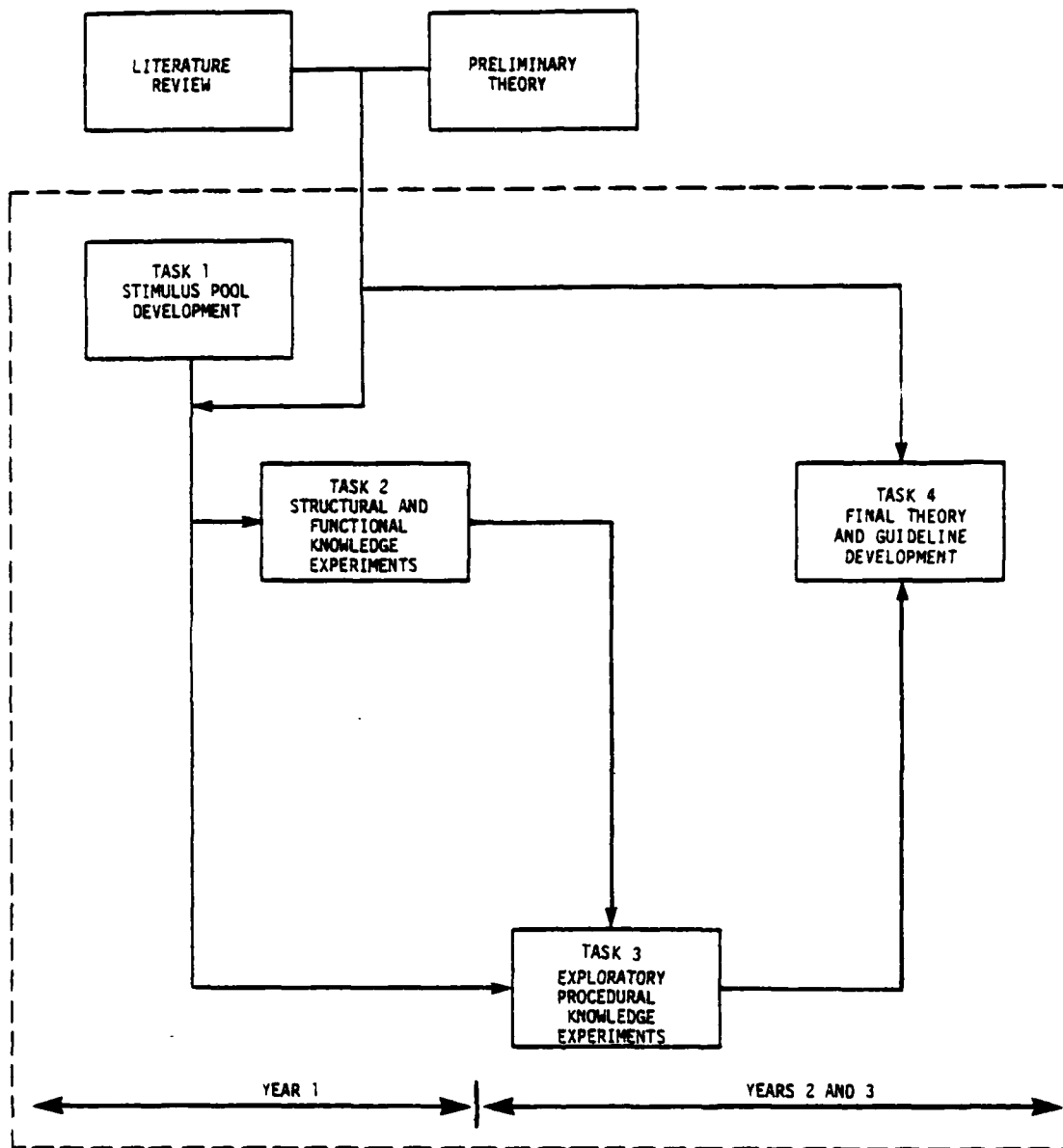

FIGURE 1-1.
OVERVIEW OF EXPERIMENTAL PROGRAM

PERCEPTRONICS

separate circuit-based tasks were studied in the second year: an error correction task, an alteration task, and a completion task. Work in the third year focused on the interplay between the structural/functional knowledge and the procedural knowledge, specifically on the development and validation of guidelines for problem solving with circuits.

2. RESEARCH BACKGROUND

2.1 Overview

The performance of complex tasks, such as maintaining mechanical equipment, modifying and adapting computer programs, and troubleshooting sophisticated electronic devices, requires highly skilled personnel. All such tasks require these personnel to have a detailed understanding of the devices that are being repaired and maintained. Thus, an understanding of how people mentally represent complex devices is necessary to train such personnel and to develop optimal man-machine interfaces that such personnel can use.

It is commonly accepted that the training of personnel to troubleshoot electronic circuits has been less than successful. In a review of the status of troubleshooting in the military services, Bond and Towne (1979) state:

The main conclusion of this report...(is that) troubleshooting of very complex systems is difficult for numerous reasons, but the critical factor is that the technician's cognitive map of essential physical relations (electronic, hydraulic, electro-mechanical, and so on) in complex equipment is often incomplete, vague, or incorrect. As long as this is so, any series of checks and test readings, though apparently well motivated and accomplished, cannot 'close in' logically on a faulty unit (pp.5-6).

The premise of the present program of research was that training programs are less successful than they could be because they fail to provide troubleshooters with the knowledge required to develop a sufficiently rich conceptual structure of the equipment they are working with. Accordingly, in this research we studied the nature of the knowledge base that is necessary to repair and maintain complex electronic devices.

This chapter presents a rationale for the work that was undertaken. Its purpose is to delineate our underlying theoretical framework for the research. Section 2.2 discusses the knowledge base required for complex problem solving. Section 2.3 discusses the nature of the mental representation of complex equipment in relation to contemporary theories of long-term memory and the representation of spatial information. Section 2.4 discusses relevant research pertaining to the nature of the mental representation possessed by novice and expert problem solvers. Section 2.5 presents the theoretical perspective that we adopted for the conduct of the research.

2.2 Knowledge Base and Complex Problem Solving

Troubleshooting entails the isolation and repair of malfunctioning components in a device and, as such, is a form of problem solving. It may be analyzed in terms of problem solving theories (see, e.g., Greeno, 1978, for a review). However, we did not focus exclusively on this aspect of the troubleshooting question. It was presumed that problem-solving procedures operate on a substrate of knowledge, which includes a mental representation, of a device. This underlying structure must be clarified before problem-solving theories can be applied.

Although much attention has been devoted to the study of the procedure people use in problem-solving, less attention has been paid to the study of the knowledge substrate required to solve complex problems. For example, the commonly studied problems (Tower of Hanoi, Missionaries and Cannibals, etc.) require a very limited information base. We felt that, in part, what characterizes good problem solvers from poor ones resides in the knowledge base they bring to problem solving tasks rather than mere differences in their problem solving strategies.

While this position may seem to be uncontroversial, it is instructive to note that much previous research has been performed that presupposes a very impoverished mental representation on the part of the problem solver. For example, troubleshooting is sometimes viewed as a decision making activity where the troubleshooter's task is to iteratively select and test system components to determine whether they are faulty (e.g., Freedy & Crooks, 1975; Rouse, 1978). From this perspective, the troubleshooter must decide which system component, among many, to test on a given iteration. Some have suggested (e.g., Bond & Towne, 1979; Rouse, 1978) that an optimal strategy to use is a procedure that eliminates half the number of components on each test cycle. To be implemented, a strategy such as this one merely requires the troubleshooter to have a list of system components in his mind. Unfortunately, it is not clear what should be on this list, nor how it should be organized. It is here that the real novice-expert differences lie.

We believed that to successfully repair complex equipment, a troubleshooter requires several types of knowledge. First, factual knowledge of the equipment is required. For example, troubleshooters must know that most electronic devices have a power supply. Second, procedural knowledge is needed. Sometimes, such knowledge is quite specific; for example, "To determine whether a capacitor is faulty, take a reading of the voltage at point x. If the voltage departs significantly from value y, the capacitor is faulty." Other procedural knowledge is much more general, as in a set of procedures for identifying what may be wrong when no power is delivered to a device. Third, the troubleshooter requires a mental representation of the faulty device, of its components and their inter-relationships to each other. The basis for this representational knowledge is provided by schematic drawings of the equipment. However, the availability of schematic drawings does not mean that the troubleshooter understands the device, nor that he can generate an accurate mental representation.

2.3 Nature of the Mental Representation

It is apparent that an expert's mental representation of a complex device is not isomorphic to a schematic drawing of the device. In fact, it contains much more information. (See Brown, Collins, & Harris, 1978 for a similar point of view.) For example, an expert readily can identify functional units within a circuit that are not directly present in the diagram. So the first step was to model the latent knowledge and the cognitive mechanisms that allow the expert to develop an enriched mental representation from a schematic drawing.

Contemporary psychological theorizing provides several approaches to this problem. One approach is to view the mental representation of spatial information in terms of connected networks (Anderson, 1976; Anderson & Bower, 1973, Collins & Loftus, 1975; Norman & Rumelhart, 1975; Schank, 1972). According to such a structural model, individual circuit components are represented by nodes in the network and the interrelationships among components form links between the nodes. Although representations of this sort can be constructed to mirror closely the circuit diagrams, they also permit the use of abstract nodes to represent the hierarchical relationship among functional groupings of components. Most of the work with these models has been done in building and testing theories of the organization of long-term memory and thus has been outside the context of problem-solving tasks. An exception is the work of Bhaskar and Simon (1977) who have undertaken an analysis of the structure of long-term memory used by students solving problems in a college-level course in chemical-engineering thermodynamics.

A second approach is to view the internal representation as a second-order isomorphism between an external object and some corresponding representational process with the brain (Shepard, 1978). According to this view, the relations among imagined objects mirror to some extent the

functional relations among the same objects as actually perceived. Studies based on this view (e.g., Cooper, 1975; Kosslyn, 1975; Shepard, 1978) have emphasized the close relationship between the physical nature of material and the chronometric properties of the response. Because of the spatial nature of circuit diagrams, isomorphic representation such as these play an important role in any model.

A third approach to the representation of knowledge is procedural. In such a view, what is known is not the static properties of a circuit diagram but ways of operating on it. A worker may know how to modify a power supply to better filter its output, with this information taking the form of procedures for altering the circuit rather than a compendium of facts about supply filters. Because of its active representation, procedural knowledge has found most use in simulation models (e.g., Winograd, 1972) and problem solving (Newell & Simon, 1972). Some models (e.g., Anderson, 1976) have incorporated both procedural and other forms of representation.

deKleer (1979) and deKleer and Brown (1980) have described, from an artificial intelligence point of view, some of the procedural strategies that are required to analyze the operation of a circuit. In particular, they emphasize the need for multiple procedural strategies. For example, deKleer (1979) hypothesizes that people use topological, functional, and geometric representations. In topological analysis, the topology of a new circuit is compared to that of previously recognized circuits; in functional analysis, the behavior of the overall circuit is determined by combining the behavior of the individual components; and geometric analysis relies on the tacit graphical language engineers use when they describe circuit topologies on paper. These representations are used to analyze circuits in terms of its "teleology." Similarly, Stevens and Collins (1980) argue that people maintain multiple representations of physical systems such as of the rainfall process.

2.4 Comparing Novices to Experts

The previous research most relevant to understanding how people represent complex equipment from schematic drawings comes from research comparing the performance of experts to that of novices. Most research in this area indicates that experts differ from novices more in perceptual, memorial abilities than in logical, problem-solving abilities. If it were simply the case that experts know more about the task than the novices, there would be little to be gained from constructing an elaborate representation of the task. However, this seems not to be so. Experts seem to have representations that differ qualitatively from those of novices. Studies supporting this position are becoming common.

Work by deGroot (1966), Chase and Simon (1973), and Simon and Chase (1973), comparing the performance of Master and weaker chess players, indicates that Masters do not "see" ahead further than the weaker players. Instead, the Masters are superior to weaker players in their ability to perform tasks involving the recall of actual chess positions. The superior performance of Masters in these tasks cannot be attributed to a generally superior visual short-term memory capacity of the Masters because when chess pieces are placed randomly on the board, recall is equally poor for Masters and weak players.

Egan and Schwartz (1979) demonstrated that expert electronic troubleshooters have a richer mental representation of circuit information than novice troubleshooters. For example, expert electronic troubleshooters are better able to remember circuit diagram information than are novice troubleshooters, and in reconstruction, the experts recalled the diagrams in groupings of functional units. The skilled technician's advantage in this task did not hold for non-meaningfully arranged symbols.

Badre (1979) has found similar results for the recall of battlefield situation displays. Military experts show a marked advantage over novices for plausible situation displays but not for randomly arranged positions. Furthermore, military experts recall battlefield units on the basis of their functional relationship to each other.

These results hold for other spatial tasks such as the recall of GO positions (Reitman, 1976) and have also been extended to other non-spatial tasks such as for the recall of computer programs (Reitman, McKeithen, Reuter, & Hirtle, 1979) and the solution of physics problems (Chi, Feltovich, & Glaser, 1979; Larkin, 1979; Larkin, McDermott, Simon, & Simon, 1980).

The most influential theoretical explanation of these data is that experts perceive spatial stimuli by coding the stimuli into groups consisting of several elements or chunks. In one version of this theory (Simon & Gilmartin, 1973), the chunks have verbal labels that can be retained in short-term memory and decoded at the time of recall. It is argued that experts quickly represent an entire spatial representation in a relatively small number of chunk labels and that these labels can be used to reconstruct the spatial representation. Pauses between successively recalled elements, the estimated size and number of chunks, and the correspondence of recall groupings in copying tasks support this hypothesis.

The data are in good agreement with the semi-hierarchical theory of the mental representation of complex equipment discussed in the following section (indeed, they were part of the motivation for our model). Moreover, our theory provides a mechanism to account for Egan and Schwartz's (1969) observation that experts can quickly label a circuit diagram as belonging to a given class (e.g., "some sort of power supply").

In sum, we do not feel that the understanding of skilled performance in tasks such as circuit analysis is possible without considering multiple domains of knowledge. All are necessary to explain the richness of an expert troubleshooter's mental constructs, and our ultimate model incorporates elements of each. In particular, we believe that the difference between experts and novices lies as much or more in the ability of experts to draw from a larger collection of operations -- or procedural knowledge -- than in an understanding of the structural and functional nature of the parts of the task or in the reference to prototypes. Much previous work has ignored the dynamic, procedural aspects in favor of more static conceptions of the tasks. The following section presents our theoretical position in more detail.

2.5 Theoretical Perspective

As one reviews the literature on the mental representation of tasks or stimuli, one is struck with the extent to which the derived representations are well matched to the task. This suggested to us that the subject is able to adopt a mental representation that is closely concordant with local processing demands. The true mental representation must have latent in it a variety of possible forms and structures. This observation dictated one fundamental principle behind the experiments that we present here: any analysis of the mental characteristic of a domain of knowledge must derive from a variety of tasks and must posit a variety of individual representations.

We started by making a distinction between two ways of classifying the content of a knowledge structure. The first refers to the substantive content of the representation, to what facts it describes; the second to the way in which the information relates to the subjects' knowledge base. Both of these viewpoints were further subdivided as is discussed below. We emphasize that this is not a dichotomy in the knowledge itself -- a

particular piece of information does not belong to one or the other -- but rather two aspects of the same mental structure, both of which must be treated to fully comprehend the information processing abilities of a subject.

Content. The content of the mental representation is composed of a number of interrelated and overlapping structures. These structures may be hierarchical in form (although this is not crucial). The hierarchical character arises from the tendency to view portions of the device as units, without examining their fine structure unless necessary. For example, one may think of a logic-circuit component as a flip-flop, without analyzing it further unless forced to do so. This hierarchical tendency has been supported in modern integrated circuits by the physical modularization of rather complex functions in single chips or modules; in computers, for example, CPUs, interface units (e.g., UARTs), and fairly extensive memory drivers may appear as single units.

The overlapping nature of the representation comes from the fact that a particular component participates in several organizations at once. In some computer designs, for example, the circuit representing the fourth bit of an accumulator may logically be analyzed as part of that accumulator, or may be considered as part of the array of fourth bits over a series of registers such as the accumulator, a program converter, etc. (It is interesting that both forms of organization are reflected in the physical design of different computers.) As a more prosaic example, an electric fuel pump in an automobile participates in both the electrical and the fuel system of the car. Presumably all of these overlapping organizations are accessible to the subject who is employed at a particular time depending on the task. The processing demands that the subject places on the mental representation enables one form or the other.

We feel that the cognitive representation of information given in a circuit diagram may be usefully described as a set of parallel networks. In part, these networks have a hierarchical structure, in that the terminal nodes represent individual circuit components (resistors, capacitors, etc.); the intermediate nodes represent either functional units (rectifiers, amplifiers, etc.), or physically proximal collections of components, and the highest nodes represent the total circuit (a power supply, an inverter, etc.).

Nature of the Knowledge. The second scheme of organization relates to the way that the information is used. Different tasks use knowledge in different ways. Although the range of possible uses probably forms a complex and multidimensional space, a good case can be made for classifying knowledge about a complicated mechanism (such as a circuit diagram) into three general classes:

- (1) Structural and functional knowledge deals with the way that a device is constructed and the role that its parts play in operation. One may know, for example, that a transformer serves to change the voltage of an AC supply, that a particular combination of transistors acts as a flip-flop, and so forth. Fundamentally, this knowledge is static; it describes the way that the device works.
- (2) Prototypical Knowledge relates one device to more general prototypes. Devices are not understood in isolation, but are related to other devices. For example, experienced technicians are able to quickly recognize that several difficult circuit diagrams represent the same class of device. This suggests a set of procedures that force the constituent elements of a circuit diagram into prototypical configurations. One portion of a circuit is a rectifier,

another a Schmitt trigger, etc. Two processes seem to be involved. First, some form of bottom-up mechanism simplifies the representation of the diagram by replacing groups of nodes with a single node. Second, a top-down mechanism attempts to fill in missing nodes in partially matched prototypes. This knowledge is rarely in the form of an exact parallel between real devices, but relates the operation of any device to an abstracted prototype. This prototypical knowledge reduces greatly the burden of the structural and functional facts.

- (3) Procedural knowledge gives ways to manipulate the device. Many tasks require more than a static comprehension of a device, demanding that some modification be made to some operation performed on it. The knowledge necessary to do this is different from the other two types, embodying a series of procedures (algorithmic or heuristic) for changing the device. Procedural knowledge is the most complex of the three, and draws heavily on the others.

We feel that training programs fail because the mental representation is unobservable, and consequently it is difficult to determine whether the troubleshooter has developed an adequate representation. Moreover, it is not clear how such a representation is attained. However, we do know that with experience, troubleshooters become more proficient at their job. Presumably, increased proficiency derived through experience is due to a more developed mental representation knowledge base.

Our goal was to obtain a better understanding of the knowledge base that skilled troubleshooters bring to bear in complex equipment. Of the three types of knowledge that we have discussed, procedural knowledge is the most difficult to study, for it is the most abstract, and depends on the

structural/functional knowledge for its operation. But it is also the most important, because this knowledge is valuable only to the extent that it lets its possessor manipulate equipment. Furthermore, preliminary work on structural/functional knowledge provides the necessary background to understand procedural knowledge.

We note that at this point we have described a general theoretical position, but not the specific models that instantiate it (for this distinction, see Wickens, 1982, Chapter I). Specific models for these processes could be formulated using a number of conventional representations such as production systems.

3. REVIEW OF FIRST-YEAR WORK: INVESTIGATION OF STRUCTURAL/FUNCTIONAL KNOWLEDGE

3.1 Overview

Reviews of the literature on the mental representation of tasks or stimuli reveal that the derived representations are surprisingly well matched to the task. This suggests that a person is able to adopt a mental representation that is closely concordant with local processing demands. The true mental representation must have a variety of possible forms and structures that are latent in that representation. Consequently, any analysis of the mental characteristics of a domain of knowledge must derive from a variety of tasks and must posit a variety of individual representations. Also, the understanding of skilled performance in tasks such as circuit analysis requires consideration of multiple domains of knowledge. That is, different domains are necessary to explain the richness of an expert troubleshooter's mental constructs, and a comprehensive model must incorporate elements of each domain.

The experiment conducted during the first year was designed to assess the structural and functional knowledge of electronic devices possessed by technicians varying in skill level. This work provided the necessary background for the investigation of procedural knowledge as related to electronic trouble-shooting. The experiment performed was a composite of a circuit-reconstruction task and a circuit-partitioning task.

The principal finding evident from the data was the large degree of variability in the performance among the subjects on the reconstruction and cluster-generating tasks, and the extent of overlap between the different ability groups on those tasks. These data stand in contrast to the relatively large differences between skill levels that appeared in the time and error measures with respect to overall performance. Even if a large

sample could provide statistically significant differences between skill levels, the size of the effect as a proportion of variability would probably not be very great. Thus, the investigation of structural/functional knowledge was not the most productive place for further research effort.

Identifiable differences in the organization of a diagram during learning and recall do not appear to be the most sensitive loci of proficiency differences. For reasonably simple and well-learned material, the physical properties of the diagram layout may dominate performance. It is conceivable that differences could appear between subjects of different proficiency levels, with the less proficient subjects being more bound by the physical construction of the target circuit, and the more proficient subjects being more bound by the logical construction. In conventionally well-drawn circuit diagrams, however, these two organizations coincide, minimizing differences in performance.

In contrast, more substantial differences are more likely to appear in the way in which the circuit diagrams are manipulated, that is, in operations that are performed on the diagrams. Even with improperly drawn diagrams, where the logical and physical aspects conflict, the expert's advantage would come through an ability to reorganize the circuit. Thus, the principal performance differences between the most skilled and least skilled subjects may be a result of differences in their respective levels of procedural knowledge. For this reason, the second year of research work was designed to examine performance on tasks that require technicians to manipulate circuits in prescribed ways. Such research, focusing on the investigation of procedural knowledge, complements the exploration of individual differences in structural/functional knowledge performed during the first year of work.

4. REVIEW OF SECOND-YEAR WORK: INVESTIGATION OF PROCEDURAL KNOWLEDGE

4.1 Overview

Knowing the way in which the mental representation of experts differs from that of novices does not directly indicate how the experts' representation leads to superior troubleshooting. Greeno (1978) makes the same point by noting that while current theorizing gives an explanation of the skill that chess masters show in the short-term recall of positions, there has been no strong theoretical analysis showing how the existence of a large store of recognizable patterns contributes to successful problem solving. Thus, tasks that tap procedural knowledge are intended to create a bridge between the structural/functional nature of the mental representation, and the procedures acting on this representation that enable problem-solving and troubleshooting activities.

Three tasks were designed to study procedural knowledge. Each task required the subject to manipulate a circuit diagram in some manner such that differences in algorithmic or heuristic procedures for changing the device could be evaluated as a function of skill level. Our interest here was primarily in the interaction of proficiency with the specific diagram manipulation. Task 1 required the subject to locate an error in the construction of a circuit on the basis of symptoms; Task 2 required the subject to change the function of a circuit; and Task 3 asked the subject to complete a missing segment of a circuit. Each experiment is described briefly below.

4.2 Task 1: Error Correction ("FIX" Task)

In this task, technicians, varying in skill level, were presented with a diagram containing an error in it and with symptoms of its malfunction. The subject's task was to find the error and to correct or fix it. While performing this task, a record was maintained of the operations that the subject used and of their order. In this way, the nature and order of the procedures could be catalogued and compared across the specified stimulus material as a function of subject skill level.

4.3 Task 2: Change Function ("ALTER" Task)

A good indication of a subject's deep-level comprehension of a circuit is provided by the readiness with which that circuit can be modified. In this experiment, subjects were presented with a circuit diagram of a device that was complete and would operate as described. The subject's task was to make a specific change in one of the circuit's parameters. For example, in the small diagram used in the first year of work, the subject might be asked to change the frequency of the tuning unit. As in Task 1, protocols of the subject's operations were catalogued and compared.

4.4 Task 3: Complete Circuit ("COMPLETE" Task)

This task required the subject to fill in a missing segment of a circuit diagram so that the circuit would perform a particular function. Circuits were constructed in which a particular segment of the diagram was left blank. These omissions subsumed a functional unit of the circuit (not just a single component), but were not so large as to require substantial redesign. As in Tasks 1 and 2, a record was maintained of the procedural steps used by the subjects to perform the task. These protocols were then summarized and compared between subject groups of different skill levels.

4.5 Subjects

The sample of 12 novice technicians for the second year of work were drawn from electronics trade schools in the Los Angeles area that offer a two-year training program in electronics to high school graduates. The 9 expert technicians were currently employed with 2 to 4 years of college education and an average of 5 years of work experience in electronics.

4.6 Materials

Six circuits were designed for use in the studies of procedural knowledge. Three of these are analog circuits with a level of complexity comparable to that of the medium-sized circuit used in the first year's work. The remaining three circuits were drawn from digital materials because (a) much of contemporary electronic equipment is digital, (b) much of the current technical training of technicians is focused on digital circuits, and (c) we wished to study procedural knowledge as it relates to both types of circuits.

Three versions of each circuit were prepared: a complete working circuit for the alter function task; an incomplete circuit for the circuit completion task; and a modified, non-working circuit for the error correction task. These circuits are presented in Figures 4-1A to 4-6C. In each figure, the complete, working version is shown in panel A, the incomplete version in panel B, and the modified, non-working version in panel C.

4.7 General Procedure

Three tasks were used to study procedural knowledge. Each task required subjects to manipulate a circuit diagram in some manner such that differences in algorithmic or heuristic procedures for changing the device

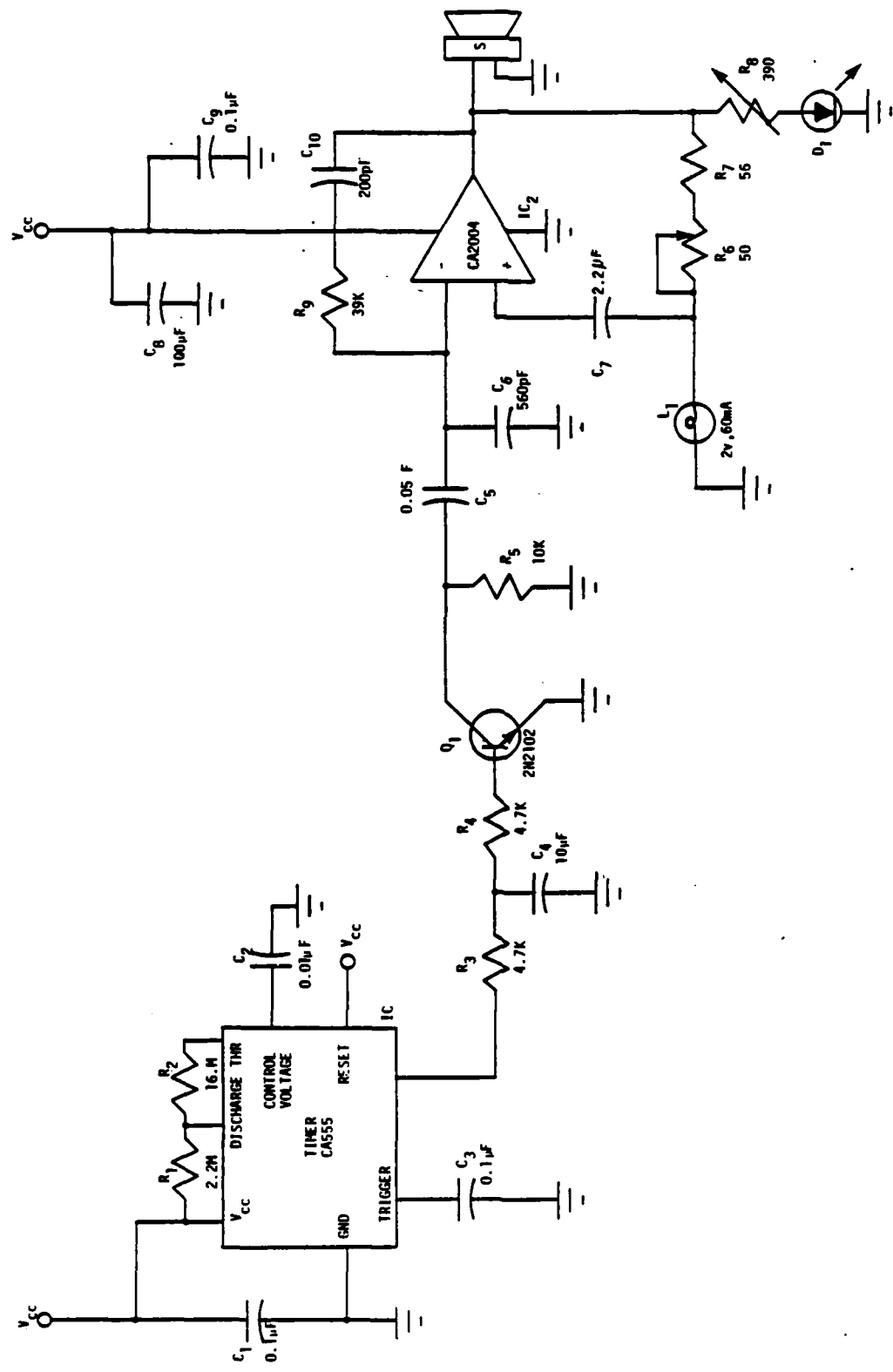

FIGURE 4-1A.
 ULTRASONIC RUDENT ELIMINATOR (ANALOG): COMPLETE, WORKING CIRCUIT
 [FOR "ALTER" TASK]

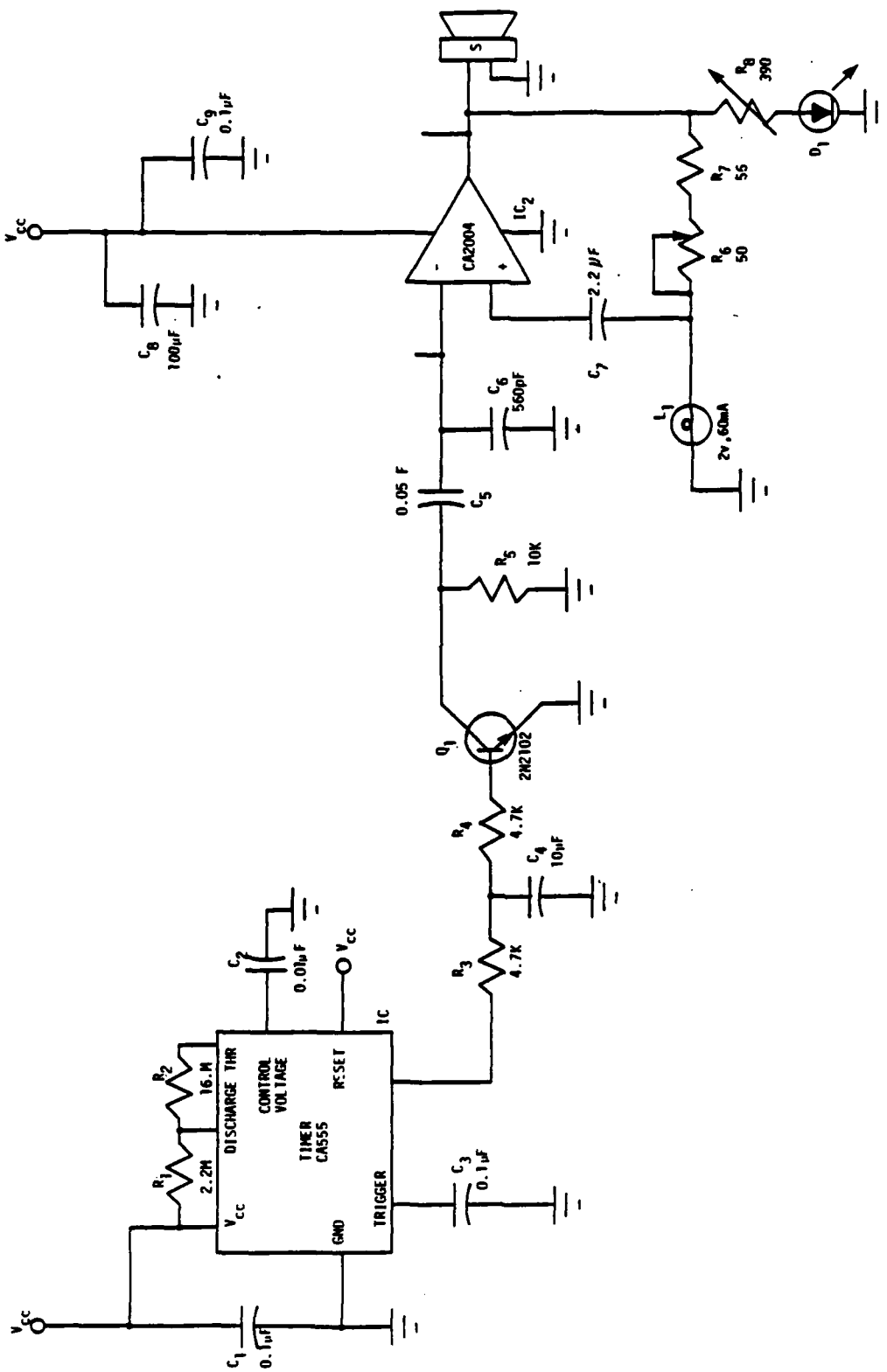

FIGURE 4-1B.
 ULTRASONIC RUDENT ELIMINATOR (ANALOG): INCOMPLETE CIRCUIT
 [FOR "COMPLETE" TASK]

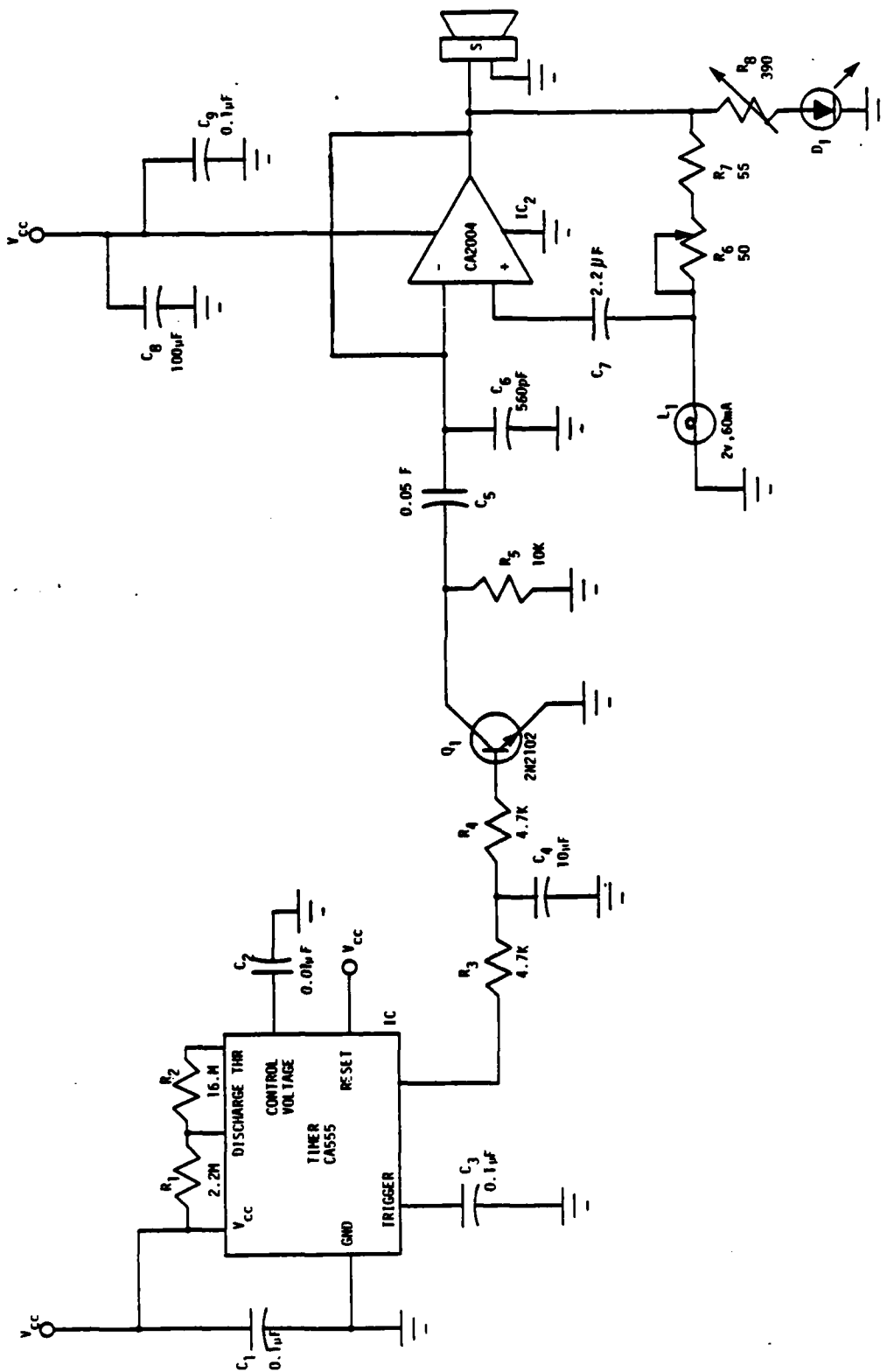

FIGURE 4-1C.
ULTRASONIC RUDENT ELIMINATOR (ANALOG): MODIFIED, NON-WORKING CIRCUIT
[FOR "FIX" TASK]

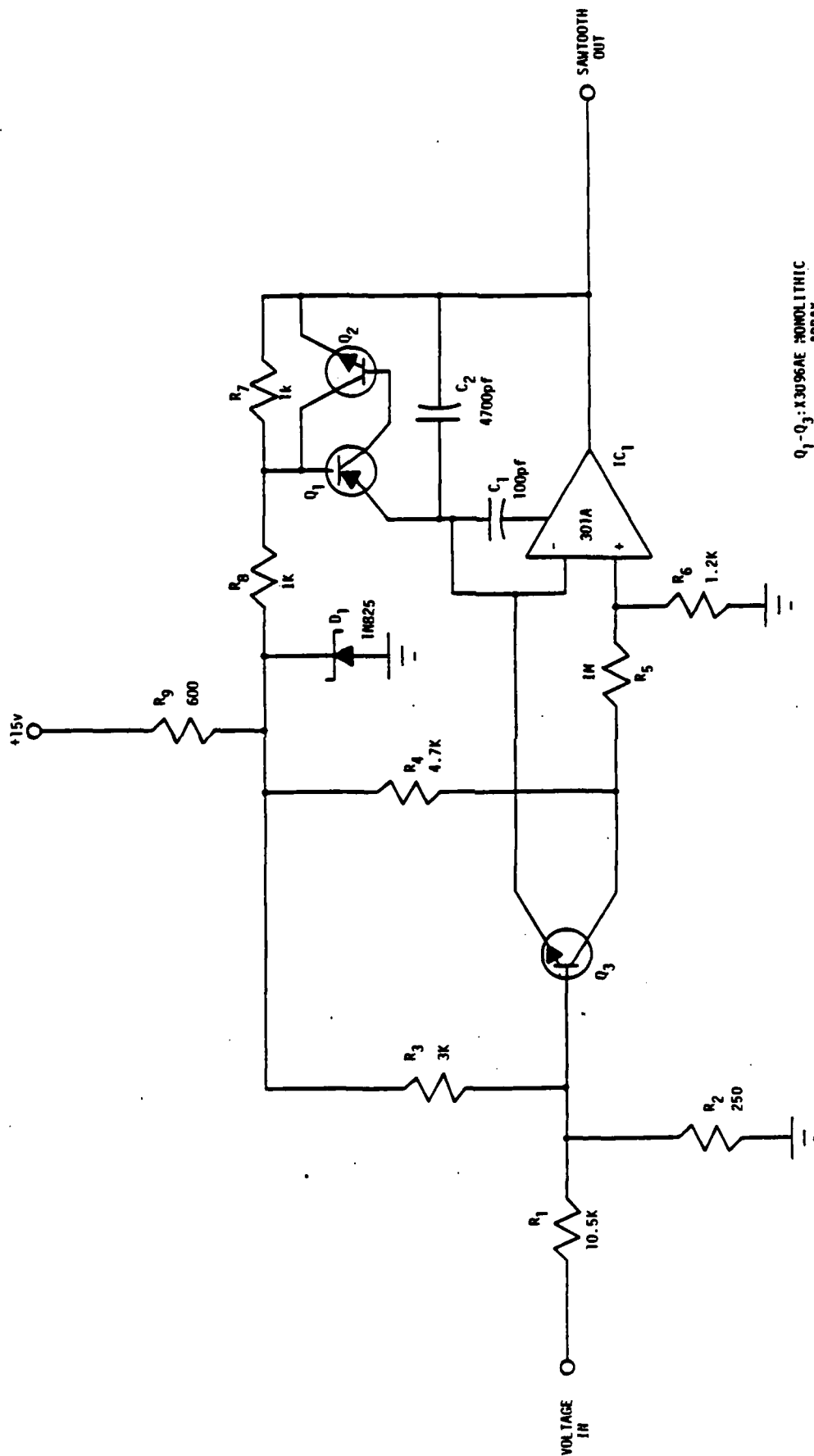

FIGURE 4-2A.
 VOLTAGE TO FREQUENCY CONVERTER (ANALOG): COMPLETE, WORKING CIRCUIT
 [FOR "ALTER" TASK]

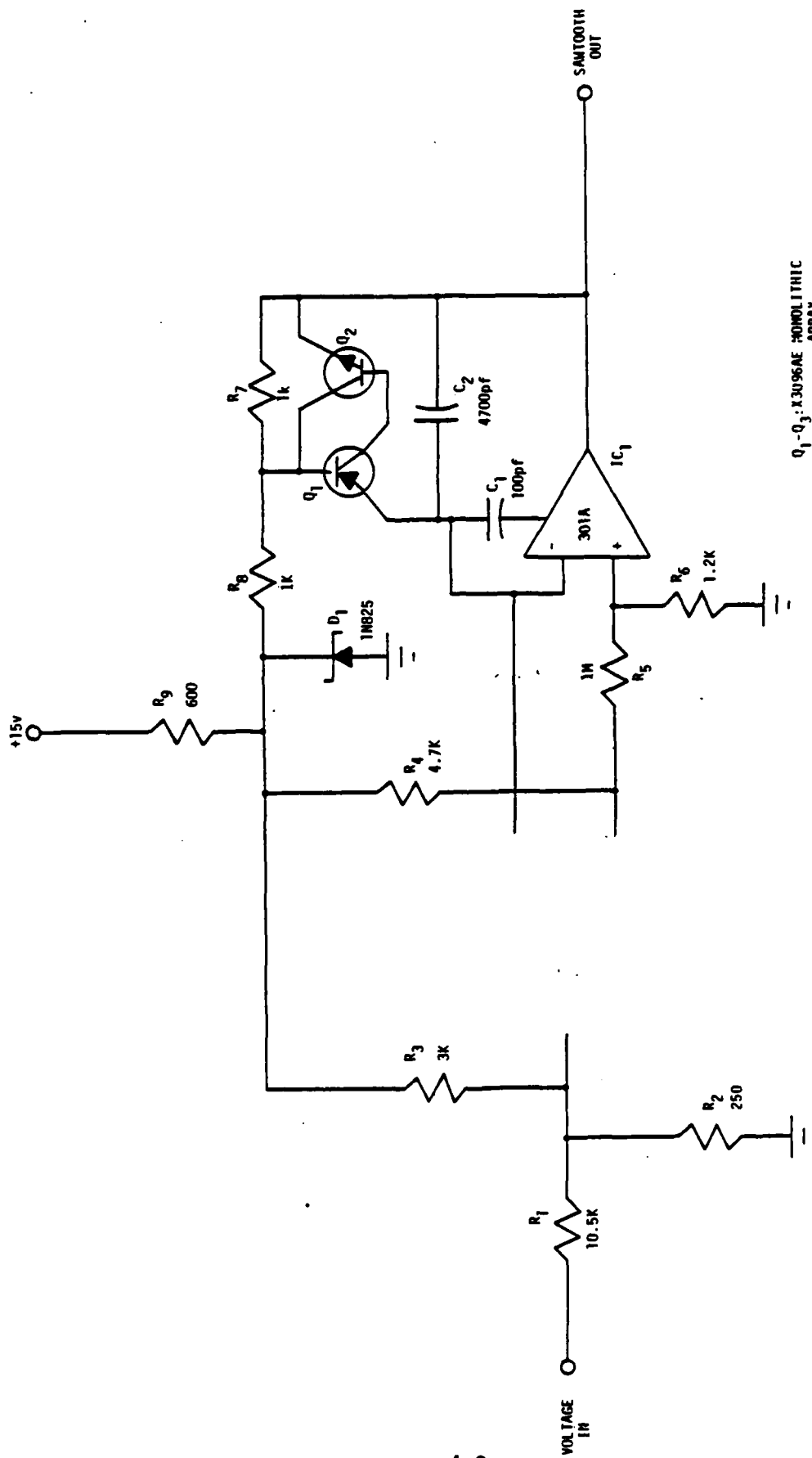
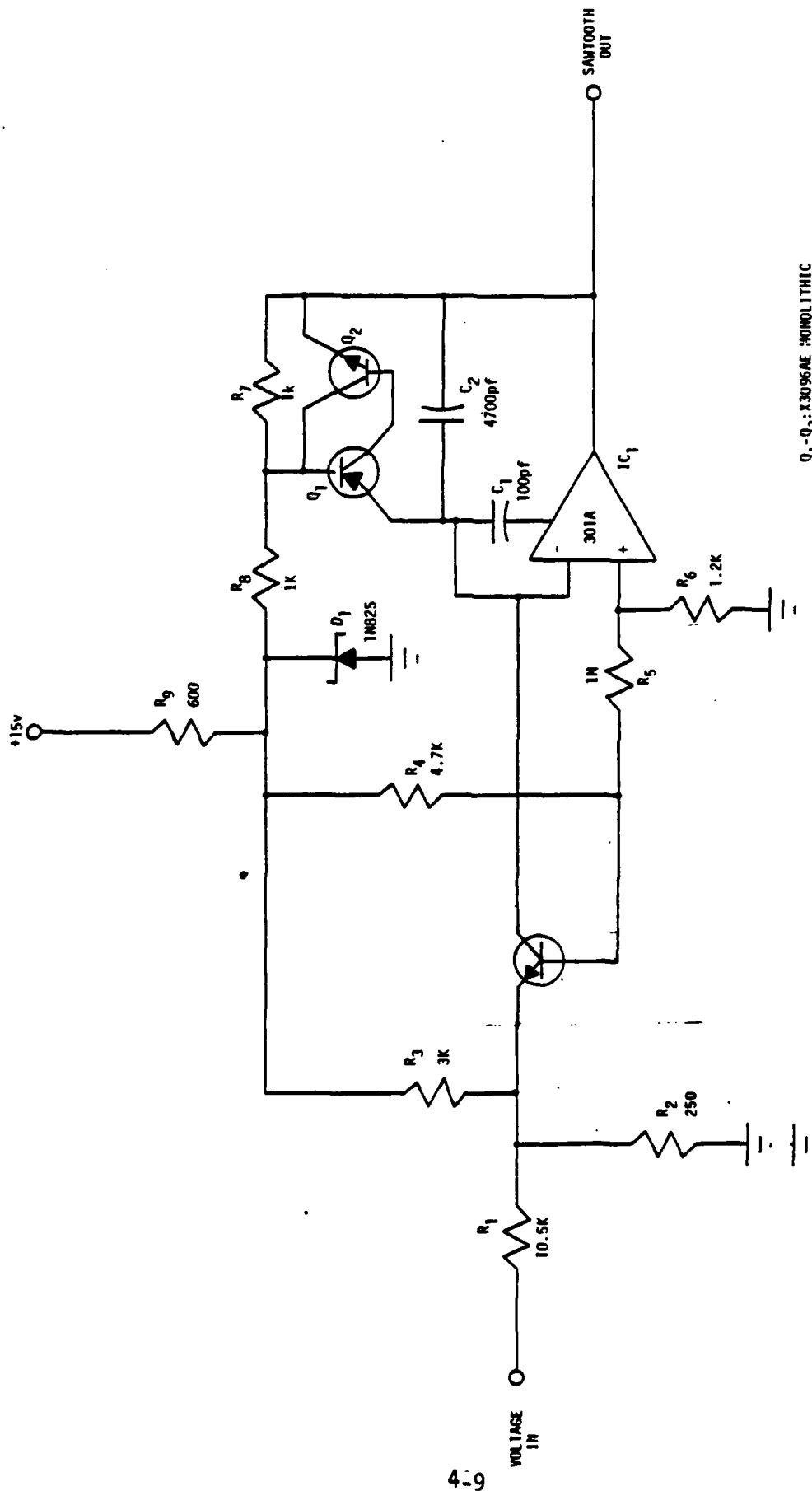

FIGURE 4-2B.
 VOLTAGE TO FREQUENCY CONVERTER (ANALOG): INCOMPLETE CIRCUIT
 [FOR "COMPLETE" TASK]



Q₁-Q₃: X3096AE MONOLITHIC ARRAY

FIGURE 4-2C.
VOLTAGE TO FREQUENCY CONVERTER (ANALOG): MODIFIED, NON-WORKING CIRCUIT
[FOR "FIX" TASK]

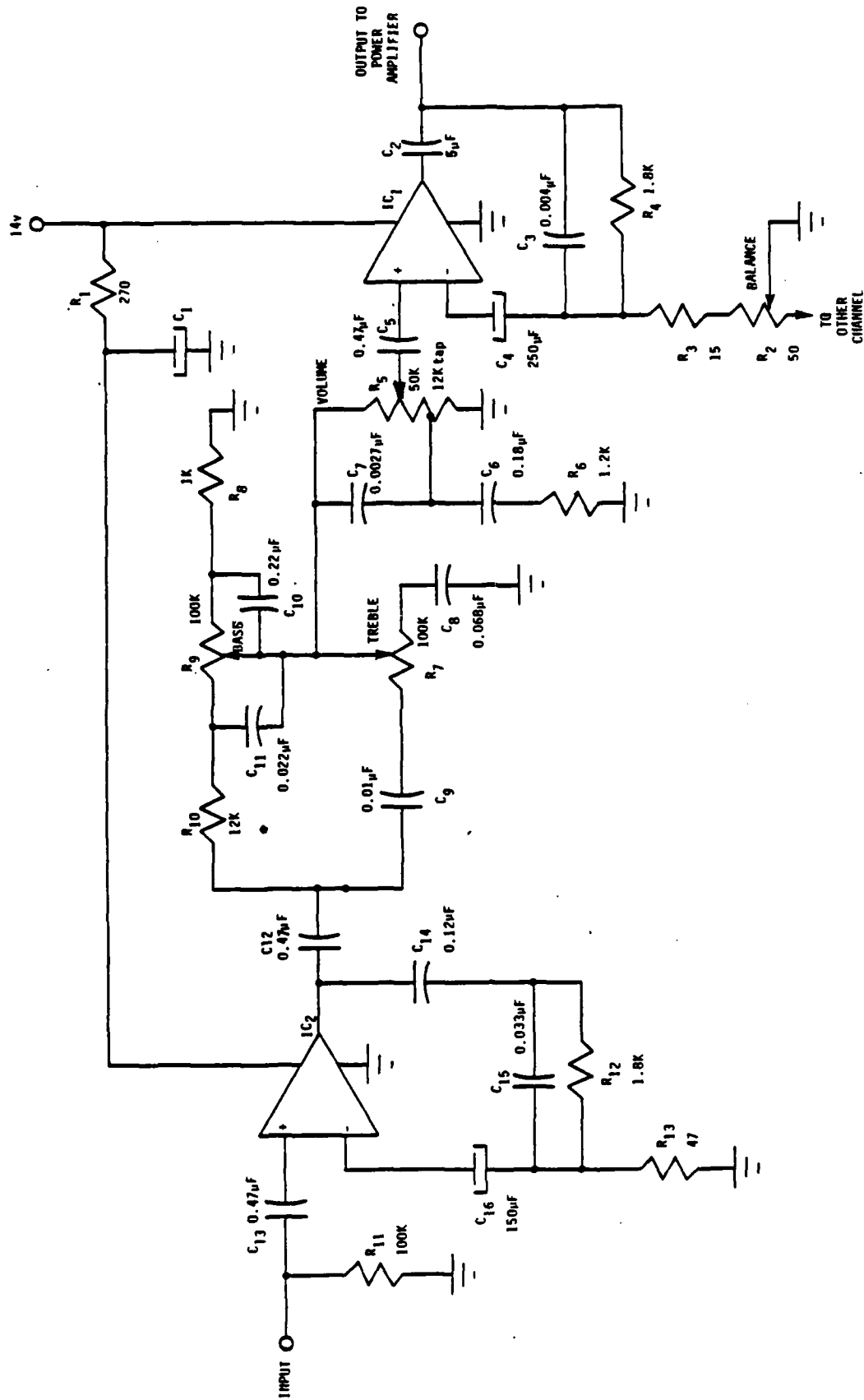

FIGURE 4-3A. (ANNEX 7A769)
 STEREO PREAMPLIFIER - ONE CHANNEL (ANALOG): COMPLETE, WORKING CIRCUIT
 [FOR "ALTER" TASK]

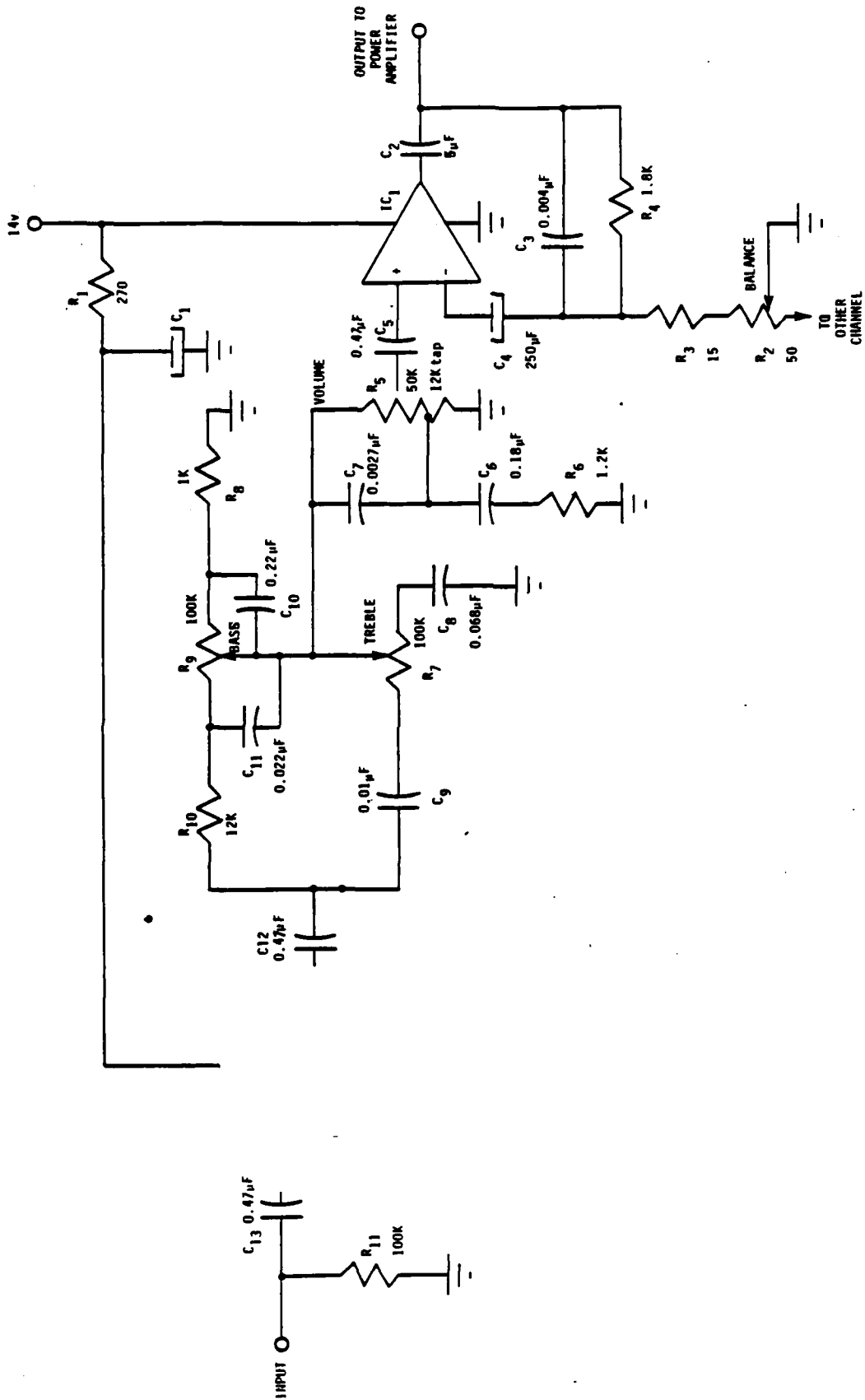

FIGURE 4-3B.
 STEREO PREAMPLIFIER - ONE CHANNEL (ANALOG): INCOMPLETE CIRCUIT
 [FOR "COMPLETE" TASK]

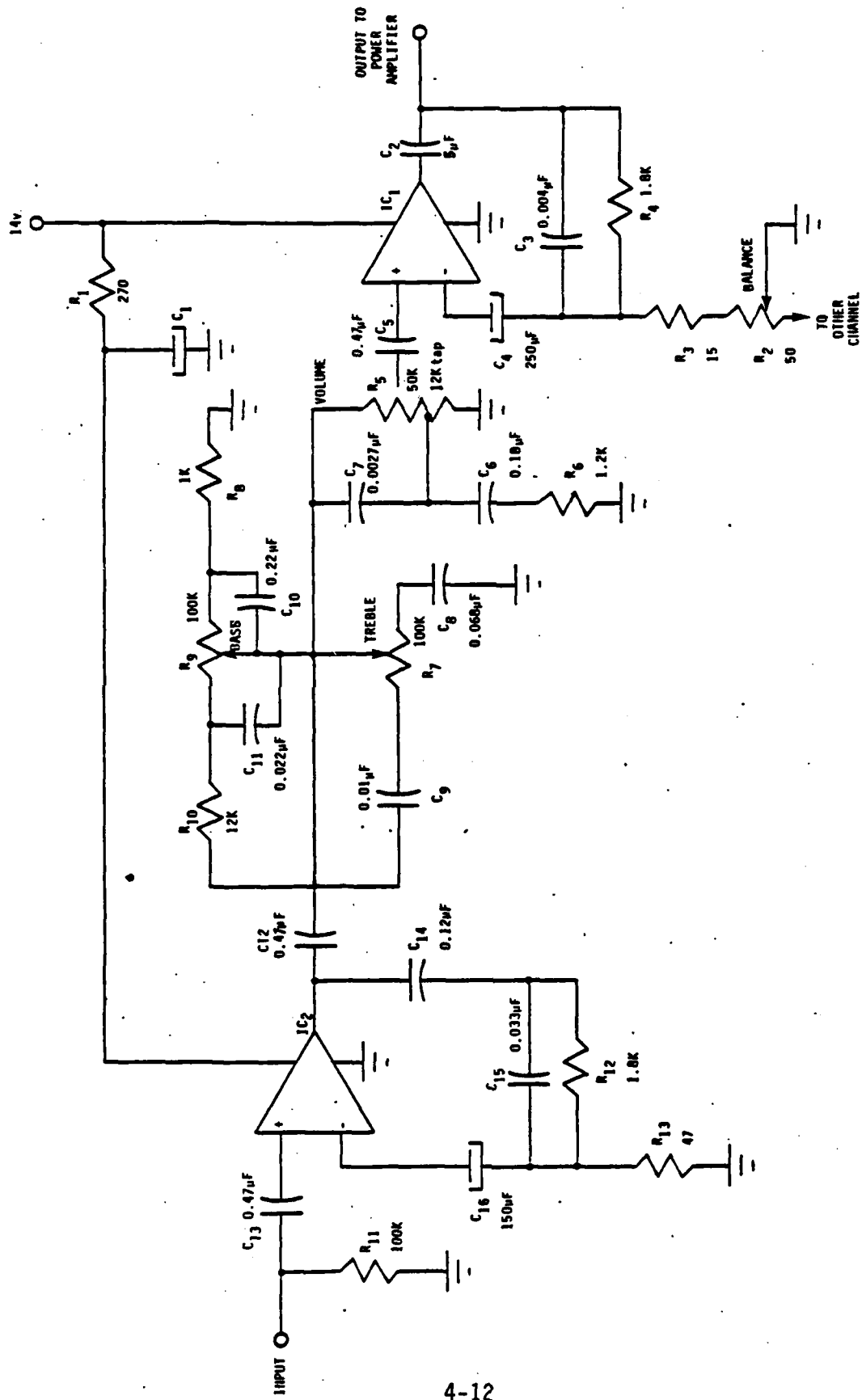

FIGURE 4-3C. (ANALOG) MODIFIED, NON-WORKING CIRCUIT
 STEREO PREAMPLIFIER - ONE CHANNEL (ANALOG)
 [FOR "FIX" TASK]

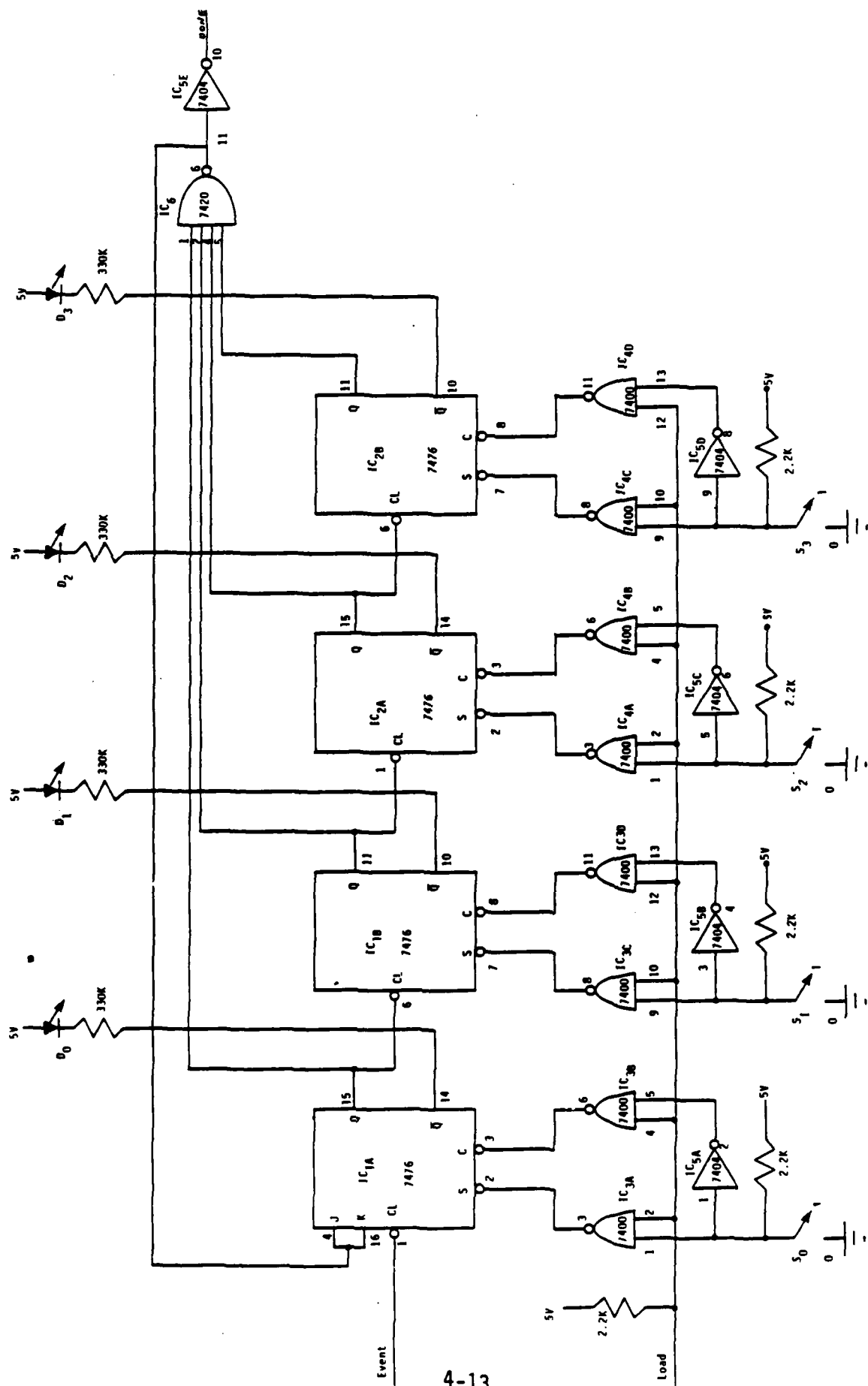

FIGURE 4-4A.
 UNIVERSAL 4-BIT BINARY COUNTER (DIGITAL): COMPLETE, WORKING CIRCUIT
 [FOR "ALTER" TASK]

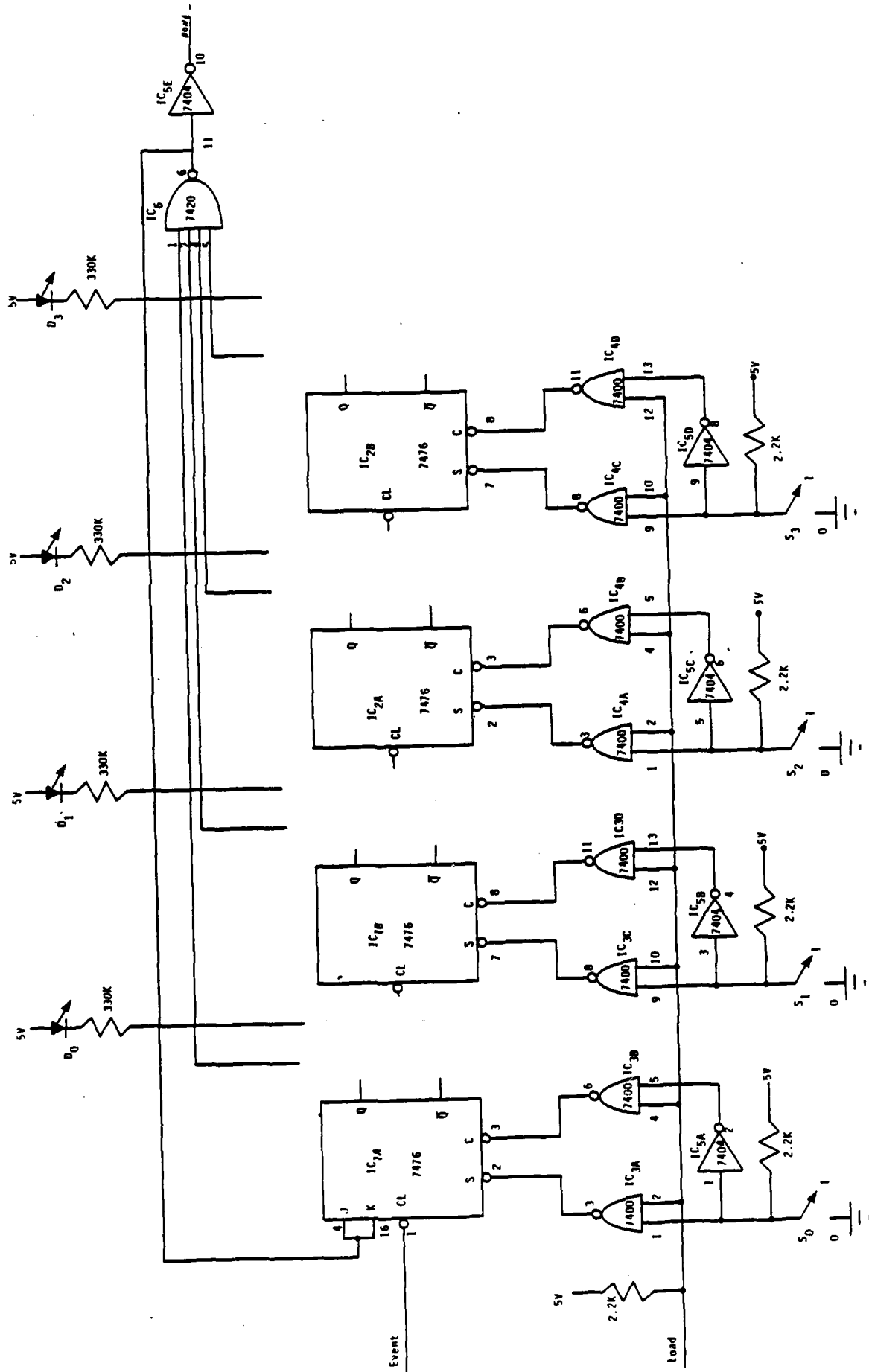

FIGURE 4-4B.
 UNIVERSAL 4-BIT BINARY COUNTER (DIGITAL): INCOMPLETE CIRCUIT
 [FOR "COMPLETE" TASK]

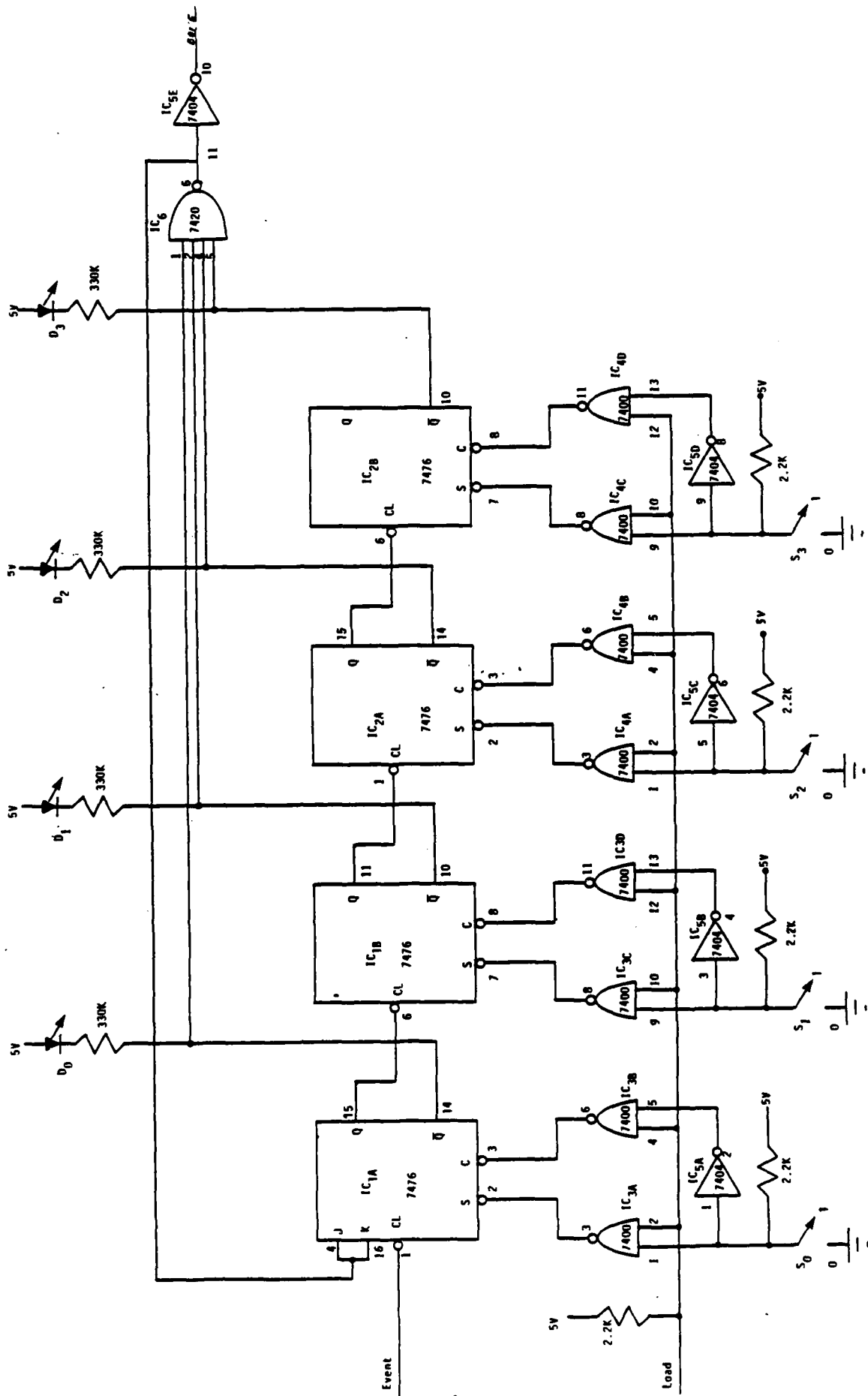

FIGURE 4-4C.
 UNIVERSAL 4-BIT BINARY COUNTER (DIGITAL): MODIFIED, NON-WORKING CIRCUIT
 [FOR "FIX" TASK]

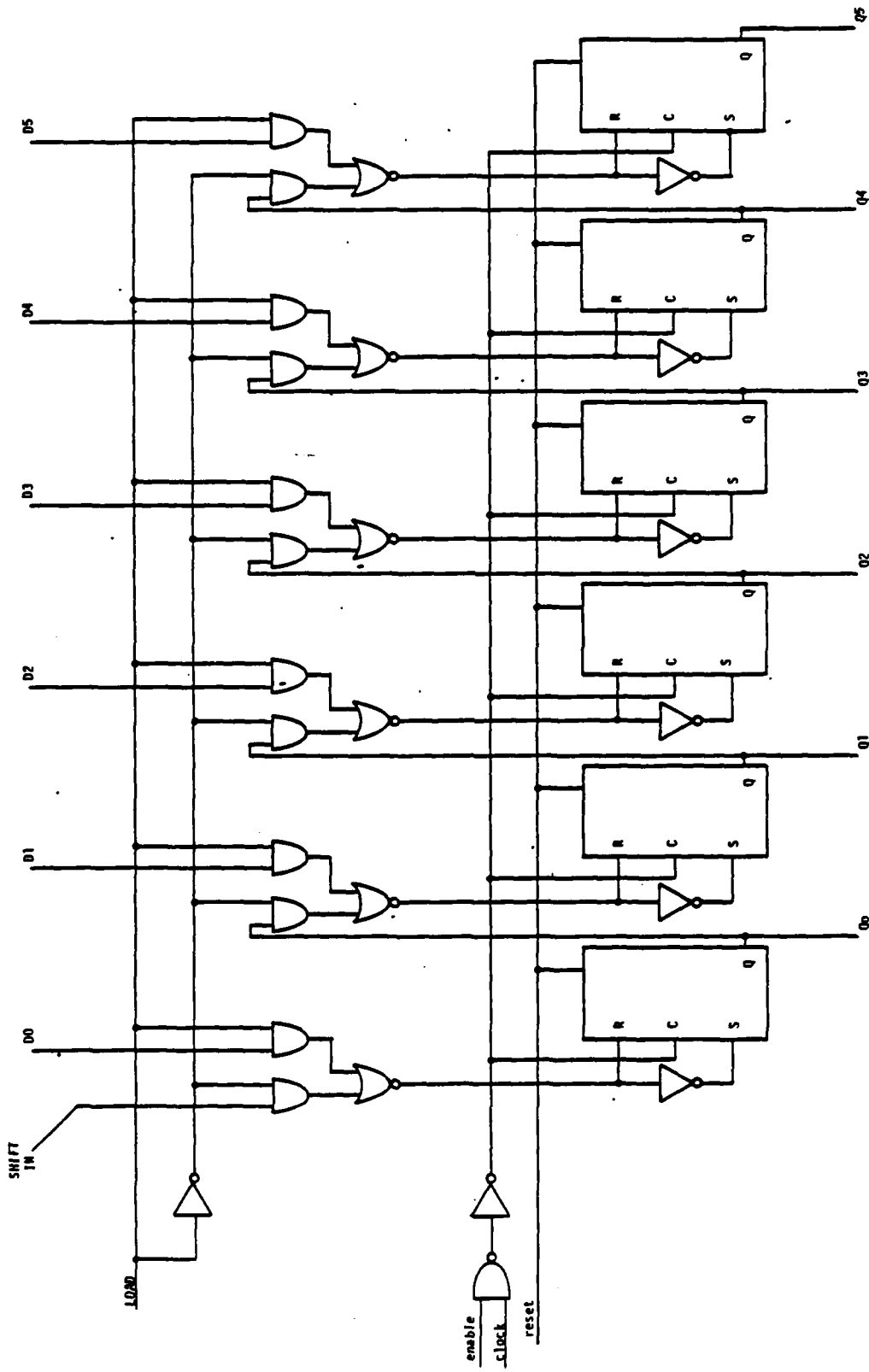

FIGURE 4-5A.
 FOUR-BIT REGISTER (DIGITAL): COMPLETE, WORKING CIRCUIT
 [FOR "ALTER" TASK]

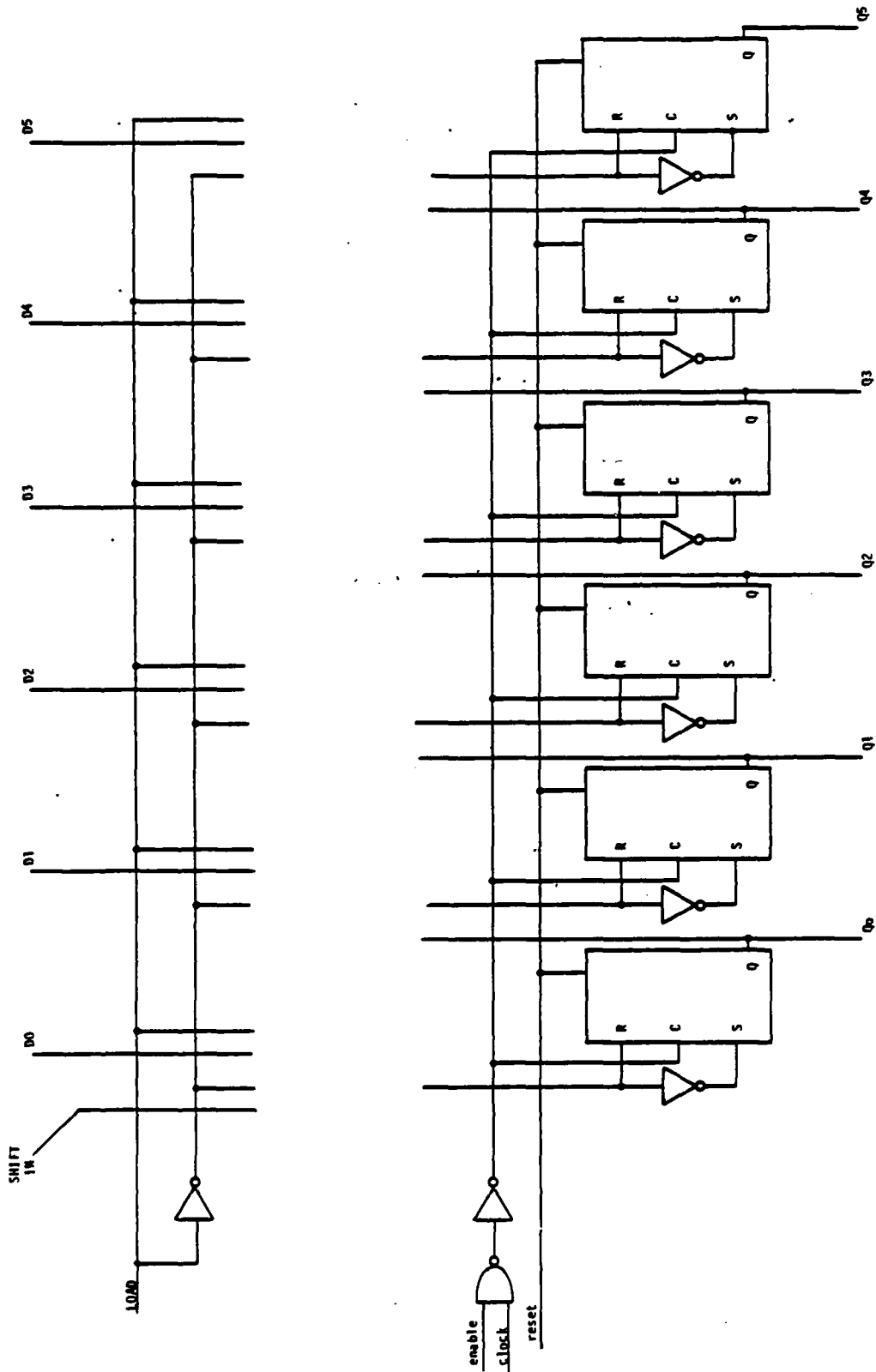

FIGURE 4-5B.
 FOUR-BIT REGISTER (DIGITAL): INCOMPLETE CIRCUIT
 [FOR "COMPLETE" TASK]

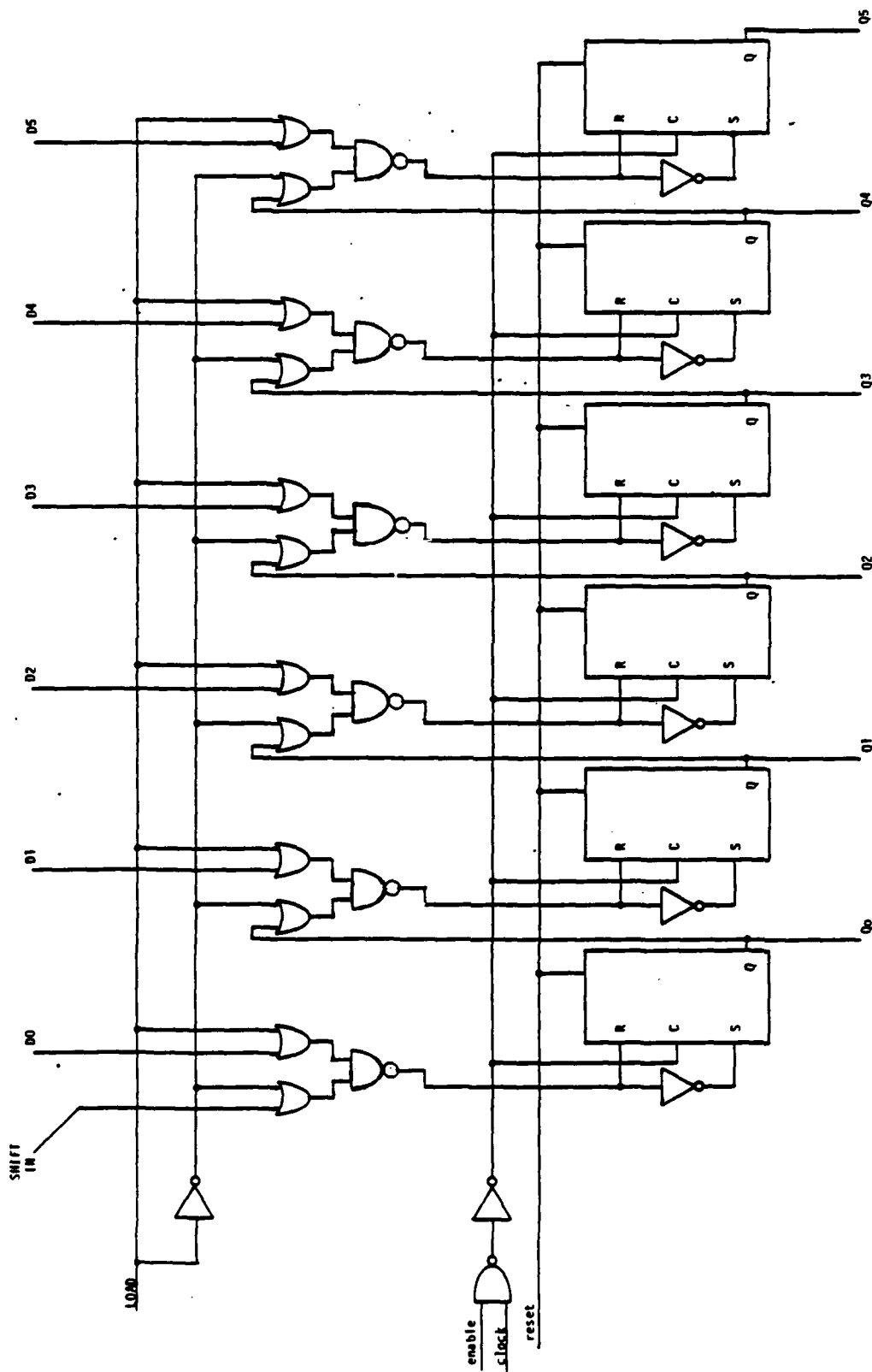

FIGURE 4-5C.
 FOUR-BIT REGISTER (DIGITAL): MODIFIED, NON-WORKING CIRCUIT
 [FOR "FIX" TASK]

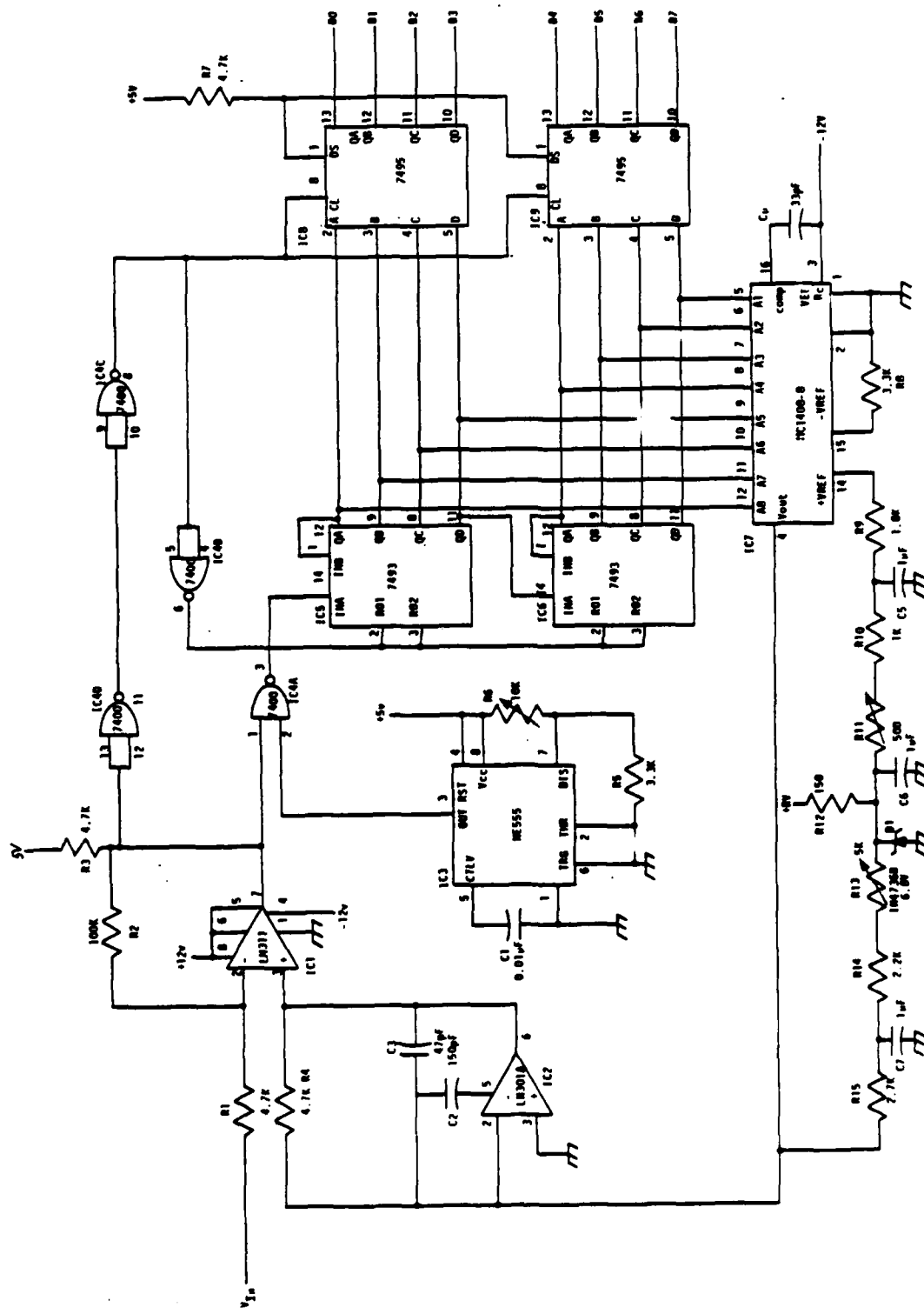

FIGURE 4-6A.
 ANALOG TO DIGITAL CONVERTER (DIGITAL): COMPLETE, WORKING CIRCUIT
 [FOR "ALTER" TASK]

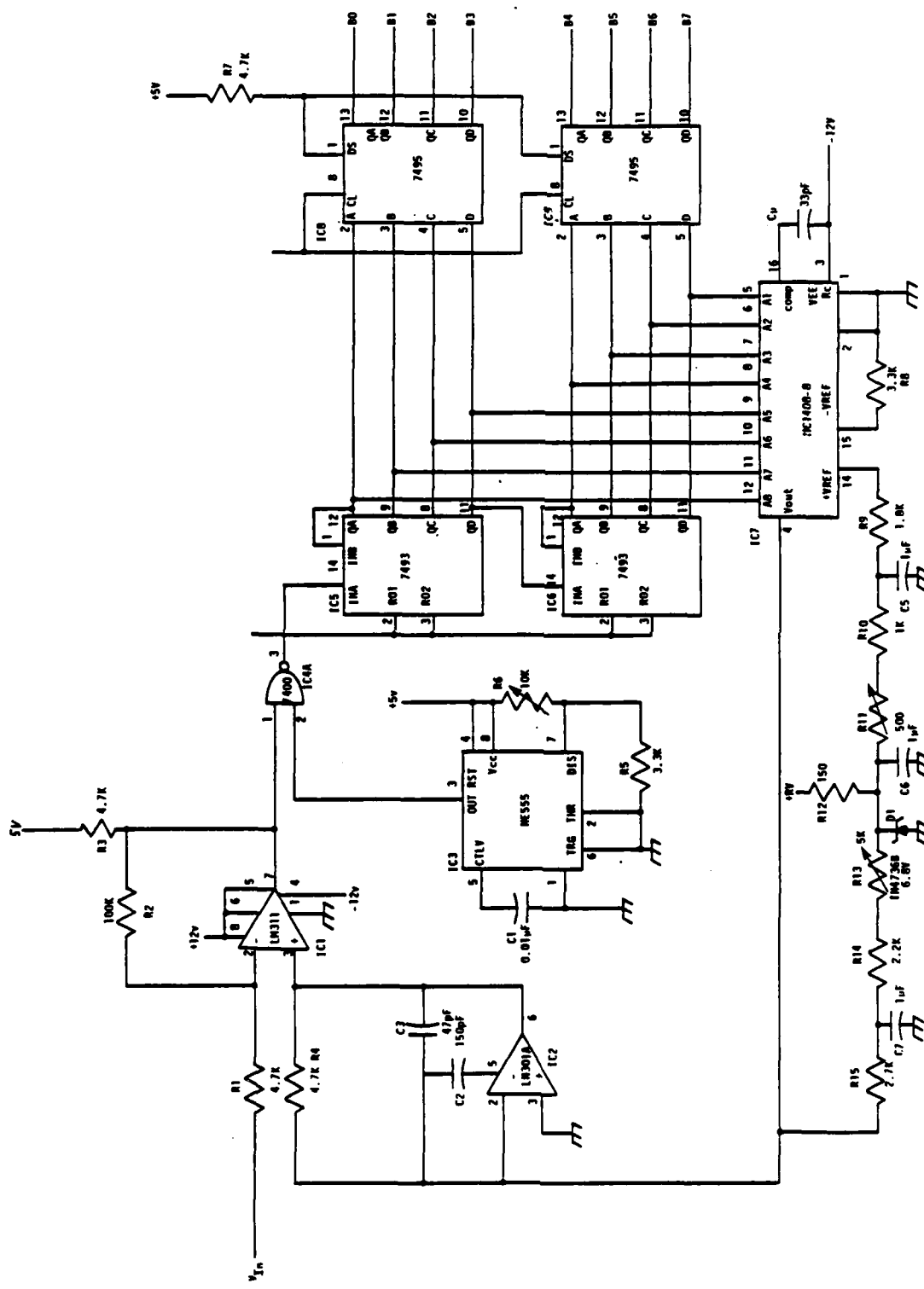

FIGURE 4-6B.
 ANALOG TO DIGITAL CONVERTER (DIGITAL): INCOMPLETE CIRCUIT
 [FOR "COMPLETE" TASK]

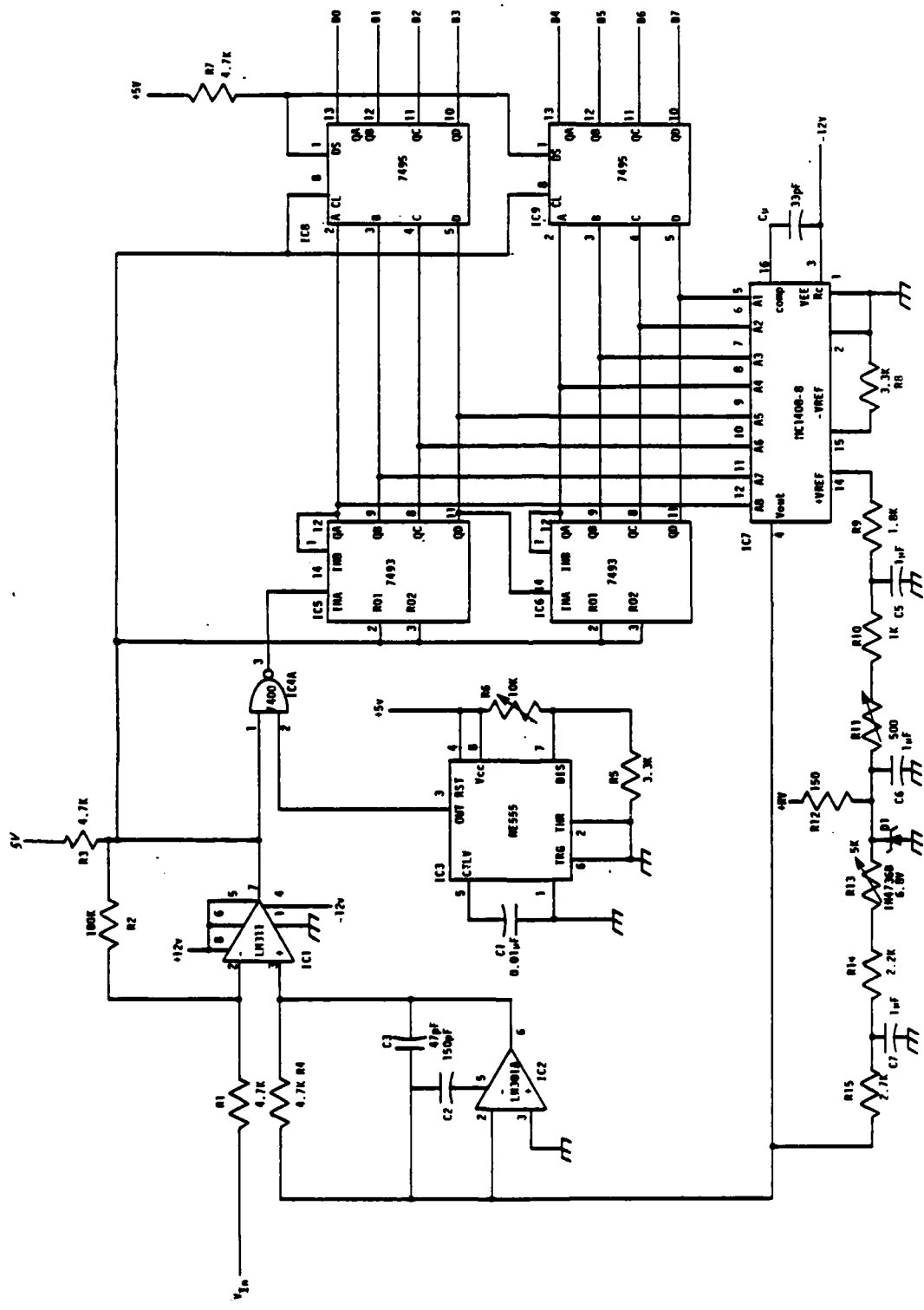

FIGURE 4-6C.
 ANALOG TO DIGITAL CONVERTER (DIGITAL): MODIFIED, NON-WORKING CIRCUIT
 [FOR "FIX" TASK]

could be evaluated as a function of the subject's skill level. Our interest here was primarily in the interaction of subject proficiency with the specific circuit manipulation required in the diagram.

The first task required the subject to locate and correct an error in the construction of a circuit on the basis of symptoms; the second task required the subject to change the function of a circuit; and the third task asked the subject to complete a missing segment of a circuit. Each subject solved problems of all three types over the course of one two-hour session. Each task was performed twice, once with a digital circuit and once with an analog circuit. The selection of circuits for tasks was counterbalanced across subjects within each skill level; and the order of presentation of the three different tasks was also counterbalanced.

Considerable effort was devoted to training the subjects to produce the verbal protocols while solving the task problems. The following instructions were read to the subjects:

"We are interested in your solutions to the problems, but we are also interested in how you arrive at your solutions. There may be several different ways to solve the problems and there are certainly several different ways to arrive at any one solution. We would like to keep a record of everything you do in coming up with your solutions. One way that we will do this is to have you think out loud as you are solving the problems. Since most people do not naturally think out loud, this may require some concentration on your part.

First, it would be most useful to us if we could write down a list of distinct steps that you go through to arrive at your final solution. To help us do this, we want you to tell us what you are thinking at each point as you work toward your solutions, and also why you are thinking about the steps you give us.

It is crucial to us that you do not, for any reason, edit anything out from your thinking. For example, if you see a step that you would like to carry out but you don't see how to do it right away, please describe what you would like to do

anyway and why you would like to do it. Also, if you start to do something and then decide against it, tell us about it anyway and why you changed your mind. Do not edit anything out. We are not only interested in the steps that lead directly to your solution, but we are also very interested in the things you think about and then decide are wrong. In short, we need a record of everything you think about until you finally come up with your solution.

To make a record of your thoughts, I will take notes on what you say. Sometimes I will have to ask you what you mean. As a backup, I will also tape record what you say so that I can go back later and fill in things that I may have missed.

To reiterate, we are not so much interested in finding solutions to the problems. We already know a few ways that the problems can be solved. What we are primarily interested in is an ongoing record of what people do toward arriving at the solutions. We are just as much interested in things that you do and then decide are wrong, as things that you do and decide are correct."

Performance on each of the three tasks was preceded by an example, using a very simple three-way light circuit. For the FIX task, an extra connection was added that would burn out the battery; for the ALTER task, the subject was shown how to add a third switch to turn the light on or off; for the COMPLETION task, connections were deleted.

Each subject's verbalizations during the problem-solution periods were tape recorded and transcribed for later analysis. The experimenter also recorded on paper supplementary notes concerning the subject's operations. To insure a hard-copy record of the operations, the subjects were asked to draw their solutions on copies of the circuit layouts. If the subject changed his or her mind after beginning a solution, an unmarked copy of the diagram was provided. This was done to maintain a complete record of all the operations attempted.

4.8 Results

4.8.1 Accuracy of Solutions. Accuracy data in terms of the proportion of problems for which workable solutions were provided for each task are presented in Table 4-1. The data confirm that the tasks studied here were sufficiently difficult to promote large accuracy performance differences with respect to skill level; and, clearly, the expert subjects did significantly better than the novice subjects on all tasks. Furthermore, given that performance by experts (at least on the FIX and COMPLETE tasks) was not perfect, it is evident that the tasks required procedural knowledge and were not identifiable "textbook" examples of standard problems. Nevertheless, as demonstrated in previous stages of this research, differences in accuracy performance are not particularly useful for understanding procedural knowledge.

4.8.2 Classification of Protocols. The transcribed protocols first were inspected for patterns by an experimenter who was blind to the skill-level classification of each subject. All of the protocols could be described in a general respect using four classifications of problem solving behavior: directed, re-directed, immediate, and trial-and-error. Directed behavior is characterized by an apparent plan toward solution, with goals and if-then operations. This procedure is similar to what Simon (1969) has called a means-end analysis where the task is to find the difference between a desired state and the existing state, and then to find the correlating process that will erase the difference. Re-directed behavior has the characteristics of directed behavior, plus the addition of at least one decision on the part of the subject that the current direction is incorrect and a new direction is pursued. This behavior is similar to "hill-climbing" (Atwood & Polson, 1976), where problem solution substates are sometimes nearer to the goal than alternative states, but they are off the solution path because of "local highs" (e.g., the Tower of Hanoi problem). Immediate solution behavior contains no sequence of operations,

TABLE 4-1

Proportion Of Problems For Which
Workable Solutions Were Provided

	FIX	ALTER	COMPLETE
EXPERT	.50	1.00	.75
NOVICE	.20	.20	.25

TABLE 4-2

Proportion of Protocols Falling
Into Each Classification As
A Function of Skill Level

	DIRECTED	RE-DIRECTED	IMMEDIATE	TRIAL-AND-ERROR
EXPERT	.56	.28	.05	.11
NOVICE	.33	.23	.13	.31

but rather a "snap" solution given quickly. This would include instances of "insight" (Wallas, 1926). Trial-and-error behavior is best characterized as "maybe I would try X; no maybe I would try Y," and perhaps indicating attempts to match the current problem with "textbook" solutions.

This behavioral classification was carried out by one of the project Principal Investigators who was blind as to which protocols were from expert versus novice technicians. Each protocol was classified systematically based on clear breaks in the solution paths, if-then statements, and admissions of incorrect attempts, and guessing. The results are presented in Table 4-2. As is obvious from the data pattern, the expert problem solution protocols were predominantly classified (56%) as "directed" behavior -- the highest level of cognitive performance. And, much of the balance of the expert protocols (28%) were classified as "re-directed" behavior. In contrast to the experts, the novices showed no predominant behavioral classification and only 33% of the protocols were classified as "directed," with nearly the same proportion being classified as "trial-and-error."

The problem solving behavior classifications also revealed interesting interactions between skill level and the nature of the task. Table 4-3 presents those data. In particular, the most dramatic difference between skill levels occurs with the ALTER and COMPLETE task; in these tasks, 75% of the protocols generated by the experts were classified as directed; whereas, 49% of the protocols generated by the novices were classified as trial-and-error. The ALTER and COMPLETE tasks are task least likely to have received prior training in the trade schools. It is reasonable that these tasks represent exercises where the novices cannot mimic the systematic behavior of experts, and therefore these type of data may prove most diagnostic in evaluating differences between experts and novices on procedural knowledge.

TABLE 4-3

Proportion of Protocols Falling
 Into Each Classification As A
 Function of Skill Level and Task

	DIRECTED	RE-DIRECTED	IMMEDIATE	TRIAL-AND-ERROR
<u>FIX</u>				
EXPERT	.67	.33	.00	.00
NOVICE	.60	.30	.10	.00
<u>ALTER</u>				
EXPERT	.50	.33	.00	.17
NOVICE	.10	.40	.00	.50
<u>COMPLETE</u>				
EXPERT	.50	.17	.17	.17
NOVICE	.20	.10	.30	.40

TABLE 4-4

Average Solution Time (Min)

	FIX	ALTER	COMPLETE
<u>TOTAL SOLUTION TIME:</u>			
EXPERT	11.9	16.8	14.5
NOVICE	13.8	15.9	8.4
<u>INITIAL STUDY TIME:</u>			
EXPERT	3.2	3.0	5.2
NOVICE	3.3	3.0	2.7

4.8.3 Solution Time. Table 4-4 presents the average problem solution time as a function of skill level and task. Most striking is the lack of differences in solution time between skill levels. The only apparent difference is in the COMPLETE task, where the experts studied the diagram for nearly two minutes longer before initiating a solution sequence. This is consistent with the finding that novices resort to trial-and-error behavior on the completion task.

4.8.4 Content Differences. Several reliable differences in the content of the protocols as a function of skill level were apparent and these important differences formed the basis for procedural guidelines that were established and evaluated during the third year of work.

- (1) Experts devoted considerable time at the beginning of each problem "learning how the circuit works" before initiating a problem-solution sequence. Specifically, experts partitioned the circuit while labeling key parts from the problem description and traced the flow of information through the circuit while noting the activity along the route. The novices' initial inspection time was spent in unsystematic viewing of the circuit.
- (2) The second major difference was in the establishment of a plan to attack the problem with clearly defined goals, and subjects who linked the desired state of the circuit to the current state. The experts were more patient, relying less on a "shotgun" approach.

- (3) The experts proceeded through a sequence of steps, making changes, additions, or deletions in the circuit, and each step was followed by tracing the effects of the action taken on the functioning of the circuit. Novices rarely studied the impact of each solution step separately; and on occasion, the impact of the entire solution was not traced through the circuit.

4.9 Conclusions

On all three tasks, the experts were more accurate with their solutions than the novices; but more importantly, the experts were classified on the basis of their verbal protocols to be more systematic, orderly, and directed in their problem solving strategies. Thus, it is plausible that the principal performance differences between the most skilled and least skilled subjects are a result of differences in their respective levels of procedural knowledge. This hypothesis was evaluated in the third year of work, in which the protocol differences were translated into guidelines toward improving circuit comprehension and troubleshooting in less skilled technicians.

5. REVIEW OF THIRD YEAR WORK: DERIVATION AND VALIDATION OF PROCEDURAL GUIDELINES

5.1 Overview

The first year of work explored a characterization of the knowledge structures that differentiate technicians of different skill levels. The second year of work increased our understanding of the procedural knowledge that technicians apply to the mental representation of electronic circuits to perform troubleshooting and problem solving tasks. These latter differences, we believe, characterize the principal differences between skilled and unskilled subjects. The results were then validated and applied.

It was possible to combine the validation of our findings with some more practical goals. Based on the differences that we have observed, our next task was to develop and test procedural guidelines for comprehending circuits, building circuits, and troubleshooting. Our approach, then, during the third year of work was to describe how expert technicians approach the range of tasks studied during the second year of work, develop specific procedural guidelines based on this knowledge, and then conduct an experiment to validate the usefulness of the guidelines toward improving performance. The latter step was accomplished by providing one group of less proficient technicians with the guidelines, and comparing their performance to that of a group of technicians with comparable skills who were not given the guidelines.

This general procedure has been employed successfully by Samet and Geiselman (1981) to develop guidelines for summarizing tactical intelligence data. The basic notion is that experts have a mental representation of their area of expertise that is concordant with the

information processing requirements that operations on the material entail. This representation can be translated to some extent into guidelines that can be used to improve the performance of other individuals who have, as yet, a more limited or otherwise less coherent mental representation of these procedures.

5.2 Procedural Guidelines

As outlined in the discussion of the second year's experiments on procedural knowledge (see Section 4.8.4), striking differences were observed in the content of the protocols produced by the experts versus less-proficient technicians. Based on those differences, the following guidelines were derived for use in the validation experiment. The guidelines apply to two parts of the problem solving sequence: The preparatory, circuit understanding phase and the problem solution phase. The guidelines were designed to ensure that subjects would: (a) attempt to understand the circuit prior to initiating a solution, (b) establish a plan of attack, (c) proceed through a sequence of goal-directed steps, and (d) trace the effects of the action.

Part 1: Understanding the circuit

PURPOSE

Start with the purpose of the circuit. Does it have an input? An output? Does it do something (for instance, make a noise)? Are there controls that you would adjust when using it? Identify these inputs, outputs, and controls.

INFORMATION FLOW

Try to identify how "information" flows through the circuit. How does the input get to the output? Where is it acted on by the controls mentioned above. Although there may be several different paths connecting input to output, try to trace one main path.

THE PARTS OF THE CIRCUIT

Try to understand what the different parts of the circuit do. What are the various components and how do they act? Two things can be helpful here:

a. Subgroups

Do certain groups of components go together and act as a whole? Several parts may form a voltage divider, an amplifier, a counter, or the like. Try to identify these groups and to label what they do. Then you can think about them together, instead of worrying about

b. Important Points

Are there certain points in the circuit that seem to be particularly important? These might be places where several of the groups you just identified connect with each other. They might be places where several signals come together or diverge, or where there is only a single connection between two parts of the circuit. Often they lie on the "information" paths that are described above. Try to decide what the signal is doing at these points.

HOW THE CIRCUIT RESPONDS

What are the dynamic aspects of the circuit? Try to see what happens when the input or the controls are changed. How does this affect the output? How does it affect the important points mentioned above. When you change the input: Does the voltage go up or down? Does the current go up or down?

Part 2: Attacking the Problem

MAKE CHANGES

Now turn to the problem that you are supposed to solve. Start by asking how the changes you are to make will affect the parts of the circuit that you identified. What changes are necessary? If the circuit does not work and you are to fix it, where might the problem be? What changes are necessary? How should the final circuit differ from what you have to start with?

TRACE THE EFFECTS OF CHANGES

When you make a change in the circuit, try to figure out what effect it will have on the rest of the circuit.

5.3 Subjects

The sample of 21 novice technicians for the third year of work were obtained from eight electronics trade schools in the Los Angeles area. A novice was defined as a student who had completed one year in an electronics technology program. In addition, it was required that each subject could interpret both analog and digital circuit block diagrams.

5.4 Materials

Four of six circuits designed for the second year of work (2 digital, 2 analog) and two of the three tasks (fix error, alter circuit) were used here again. This manipulation allowed the data from this study to be compared to those generated by the expert technicians from the second year of work. The specific circuit diagrams used are presented in Figures 4-1A, 4-1C, 4-2A, and 4-2C, Chapter 4.

5.5 Design and Procedure

Each subject was assigned to one of three conditions with seven subjects per condition. The subjects in the Suggested Guidelines condition were instructed in the procedural steps presented in Section 5.2. Another group of subjects also was given the guidelines plus they were forced to comply with the suggested procedures (Mandatory Guidelines condition). This was accomplished through repeated reminders to attend to each section of the guidelines. The third group served in an Activity Control condition, to test the possibility that improved performance with the guidelines could be due simply to increasing the amount of time a novice spent with the circuit prior to problem solving.

The control group was instructed to increase its activity relative to the circuit diagram in the first phase. Subjects were given no guidance regarding the second problem solving phase. The control activity task instructions were as follows:

Part 1: Becoming Familiar with the Circuit

LIST THE PARTS

Make a parts list on a blank sheet of paper. Use a heading for each kind of component (resistor, diode, etc.) that the circuit uses. Next to each heading draw the symbol used to represent that component. Below each heading list the values of that component that appear in the circuit and how many of each value are used (for example, 20 ohm: 3 10K 1hm: 1, etc.).

REDRAW THE CIRCUIT

On a blank sheet of paper make a copy of the circuit diagram. The important thing is to copy the electronic logic of the circuit, not necessarily to draw the exact picture. You may change the relative positions of the components if you feel it will make the diagram clearer. Use the same labels for the components as given in the original diagram.

Part 2: Attacking the Problem

Now proceed to solve the problem.

Accompanying both the guidelines and the activity tasks was an example circuit of comparable quality to the actual problems and additional text and diagrams showing how to carry out the guidelines of activity tasks.

Each subject altered two circuits (one analog and one digital) and fixed two different circuits (again, one analog and one digital) under one of the three problem solving conditions (Suggested Guidelines, Mandatory Guidelines, or Activity Control). Thus, four different problems

represented a unique set in that they were randomly selected without replacement from a pool of 24 different combinations of problem task, circuit type, and testing order.

As in the second year's experiment, the subjects were given considerable training on the production of verbal protocols while solving the problems. In addition to explicit instructions prior to problem solving, they were prompted during problem solving by the experimenter's use of comments such as "What are you thinking about now?" or "What are you trying to do now?" This sort of prompting occurred when subjects had not spoken for approximately 30 seconds.

After telling the subject that verbal protocols were desired from him, the experimenter read the following instructions aloud.

"First, let me give you a quick definition of a verbal protocol. Basically, it is thinking out loud. This means that while you are solving the problems, you must also be monitoring your own thoughts and make them known to us by saying them aloud.

Our purpose in having you do this is that we are interested both in your solution to each problem and how you arrive at that solution. This is because there are usually several different ways to arrive at any one solution. So we will keep a record of everything you do in coming up with your solution. One way that we will do this is to have you think out loud as you are solving the problems. I should point out that since most people do not naturally think out loud, this may require some concentration on your part.

We would like to be able to write down a list of distinct steps that you go through in order to arrive at your final solution. You can help us by telling us what you are thinking at each point as you work toward your solution, and also why you are thinking about the steps you give us.

Do not for any reason edit anything out from your thinking. For example, if you see a step that you would like to carry out, but you don't see how to do it right away, go ahead and tell us what you would like to do anyway and why you would like to do it. Also, if you start to do something, and then decide against it, tell us about it anyway, and why you changed your mind.

We are not only interested in the steps that lead directly to your solution, we are also very interested in the things you think about and then decide are wrong. We need a record of everything you think about until you finally come up with your solution."

Before presenting the problems to the subject, the experimenter gave him a printed set of guidelines or activity tasks to study. In addition, keywords from the guidelines or tasks were posted on the wall directly in front of the subject to remind him of the steps involved. Next, the experimenter explicitly demonstrated how to perform the presolution phase, involving the guidelines or tasks, using a problem whose difficulty level was comparable to those the subject would solve.

During the problem-solution phase, the experimenter did not disrupt the subjects in the Suggested-Guidelines or Activity-Control conditions to remind them to use the guidelines. In contrast, the experimenter repeatedly reminded the subjects in the Forced-Guidelines condition to attend to each section of the guidelines. Their performing of each guideline task was verified by their verbal protocols. An additional

measure taken with these subjects was to withhold the statement of the problem task for a given circuit until the presolution guideline activities were completed.

5.6 Results

The performance of the technicians was compared between conditions in this experiment (Activity Control, Suggested Guidelines, Forced Guidelines) and with the performance of the expert and novice technicians from the second year of this research program. Three variables were studied: Accuracy of solutions, classification of solution protocols, and solution time.

5.6.1 Accuracy of Solutions. Accuracy data in terms of the proportion of problems for which workable solutions were provided for each task are presented in Table 5-1. A solution that was completely correct was assigned one point; whereas, a solution that was close to correct but incomplete was assigned one-half point.

The pattern of results shown in Table 5-1 is highly regular. The performance of both the Suggested Guidelines group and the Forced Guidelines group was more similar to the Experts from Year 2 than to the Novices (No Guidelines) from Year 2. Thus, the guidelines appear to have been effective: the accuracy of performance was enhanced by 43% in each of the guidelines conditions as compared to

This conclusion is complicated somewhat by the outcome for the Activity-Control group. These subjects were not given instructions that would alter their problem-structuring or problem-solving behavior, but rather they were asked to perform two tasks that would increase their interaction with the circuits prior to approaching the problems. These tasks were to make a parts list and to redraw the circuit in a new layout. The technicians in this condition exhibited accuracy scores that also were

TABLE 5-1

Proportion Of Problems For Which
Workable Solutions Were Provided

POPULATION	FIX	ALTER
EXPERT (YR 2)	.50	1.00
GUIDELINES (YR 3)	.52	.73
FORCED GUIDELINES (YR 3)	.50	.75
NOVICE (YR 2)	.20	.20
ACTIVITY CONTROL (YR 3)	.63	.75

more similar to the Experts from Year 2 than to the Novices (no guidelines) from Year 2. From this result, it would appear that the element of the guidelines that promoted interaction with the circuits prior to approaching the problem was the key to the enhancement of performance.

An alternative hypothesis that might explain this result is that the skill level of the subject population was significantly different in the Year 3 sample from that of the Novice group from the Year 2 possibility. This sample does not seem likely given that the subjects were obtained from the same electronics trade schools and they were at the same stage in their education.

5.6.2 Classification of Protocols. As in the second year of work, the transcribed protocols first were inspected for patterns by one of the project's Principal Investigators. This time, however, the protocols also were inspected for patterns by a research assistant such that a measure of inter-judge reliability could be computed. Each judge worked independently and was blind to the condition assignment of each subject. All of the protocols were described using the four classifications developed in the Year 2 work: namely "Directed," "re-directed," "immediate," and "trial-and-error." Each protocol was classified systematically based on clear breaks in the solution paths, if-then statements, and admissions of incorrect attempts and guessing. The two judges agreed on the classification of 84% of the protocols; the remaining instances were discussed by the judges to achieve 100% agreement.

The classification results are presented in Table 5-2. As was the case with the accuracy data, all three groups from the third years work performed more like the Experts than the Novices (no guidelines) from Year 2. These protocols were predominantly classified as (56%) as "directed" behavior -- the highest level of cognitive performance. And, much of the balance (31%) were classified as "re-directed" behavior. In contrast, the

TABLE 5-2

Proportion Of Protocols Falling Into
Each Classification As A Function Of
Skill Level And Condition

	DIRECTED	REDIRECTED	IMMEDIATE	TRIAL AND ERROR
EXPERT (YR 2)	.56	.28	.05	.11
GUIDELINES (YR 3)	.58	.33	.00	.08
FORCED GUIDELINES (YR 3)	.50	.25	.15	.10
NOVICE (YR 2)	.33	.23	.13	.31
ACTIVITY CONTROL (YR 3)	.57	.31	.06	.06

Novices with no guidelines from Year 2 showed substantial "trial-and-error" behavior. Thus, while the guidelines derived from the problem-solving protocols of the Experts were successful for altering the behavior patterns of novices, so were the activity tasks given to the control subjects. This again suggests that the effective component of the procedural guidelines was the enhanced interaction with the circuit prior to addressing the problem. This activity appears to have been instrumental in disrupting the unsystematic matching of the current problem with textbook examples that would characterize the novices' behavior as "trial-and-error" or "immediate."

5.6.3 Solution Time. Table 5-3 presents the average problem solution time as a function of problem and skill level or condition. Most striking is the differences overall between Year 2 and Year 3. Although the two guideline groups and the Activity-control group from Year 3 performed like the Experts, both in terms of accuracy and behavior pattern, these subjects required considerably longer times to arrive at their solutions. This suggests that the guidelines and activity tasks altered the problem-solution behaviors in ways that were effective, but were not used routinely by the Novice technicians.

5.7 Conclusions

Without guidance (Year 2), Novice technicians exhibited in systematic, "trial-and-error" or "immediate" solution behavior toward solving problems with circuits; whereas, Expert technicians showed directed behavior that is characterized by an apparent plan toward a solution, with goals and if-then operations. This difference would be relatively uninteresting if it were simply an ephiphenomenon of skill level rather than a causal influence. However, with guidance to first understand the circuit before initiating a solution sequence, and then to map out a goal-directed strategy, the behavior patterns of Novices resembled those of Experts with an

TABLE 5-3

Average Solution Time (MIN)

	FIX	ALTER
EXPERT (YR 2)	11.9	16.8
GUIDELINES (YR 3)	19.9	29.7
FORCED GUIDELINES (YR 3)	22.8	34.4
NOVICE (YR 2)	13.8	15.9
ACTIVITY CONTROL (YR 3)	24.4	28.5

accompanying increase in the quality of the solutions. Thus, the results from the third year of work suggest that at least some major differences in the quality of performance by Expert versus Novice technicians lie in their patterns of problem-solving behavior.

Furthermore, the differences in problem-solving behavior appear to represent a production deficiency. That is, technicians who simply were forced to perform activities with the circuits before addressing the problems also performed more like Experts than uninstructed Novices, both in terms of accuracy and the pattern of problem-solving behavior. Novices not specifically told to first understand the circuit or to establish a goal-directed plan did so in any case as a result of having constructed a parts list and re-drawing the circuit layout. Thus, the effective behaviors already were a part of the Novices' repertoires, but in the absence of required preliminary activities with the circuits, a form of template matching of the current problem with previous examples in memory was employed.

It seems reasonable that the activity tasks enhanced the subjects' understanding of the circuits, and thereby induced a systematic plan for solution. The solution-time data suggest that the Novices use of systematic plans is not routine, as they required more time to arrive at the solutions than the Experts.

6. GENERAL CONCLUSIONS

The purpose of this program of research was to identify differences in knowledge that are characteristic of the distinction between Expert and Novice technicians, and to validate the explanatory power of these differences in controlled experiments. The first experiment (Year 1) was designed to examine differences between skill levels in the structural/functional knowledge base. That experiment revealed great individual differences among technicians in structural/functional knowledge as inferred from performance of circuit reconstruction and circuit partitioning tasks. These individual differences overshadowed most differences between Experts and Novices. Nevertheless, the Expert-Novice distinction was confirmed in both accuracy and performance time data. It was therefore concluded that the interesting differences between Experts and Novices do not lie in structural/functional knowledge of circuits.

The second experiment (Year 2) revealed clear differences between Experts and Novices on procedural knowledge on how to fix, alter, complete circuits. These differences, which were quantified through analyses of recorded problem solution protocols, were translated into guidelines for troubleshooting and altering circuits. In particular, Experts reliably tried to understand the circuit before initiating a solution sequence and the solution sequence was systematic and apparently goal-directed.

In the third experiment (Year 3), the problem-solving behavior of Novices was successfully changed such that they mimicked the Experts from Experiment 2 on their procedural patterns for troubleshooting and altering circuits. Correspondingly, the quality of the solutions was improved dramatically, by 43%. Thus, the systematic problem solving behavior of the Experts appears not to have been an epiphenomenon of their expertise, but rather it seems to be an integral component of their expertise.

In addition, it appears that the Novices were capable of generating the effective behaviors on their own when they were required to interact with a circuit prior to initiating a problem-solution sequence. Thus, one important stage in the transmission from the Novice to the Expert level of expertise is the disruption of a strategy where the current problem is matched unsystematically with previous examples in memory, such that a more systematic approach is developed and executed based on an understanding of the circuit. This component of the transition from Novice to Expert levels of skill has been identified in other domains of knowledge, including computer programming (Adelson, 1984) and chess (Chase & Simon, 1973), where Experts are said to form abstract representations of problem spaces while Novices rely on more concrete representations.

The present results suggest that the problem-solving behavior and performance of Novice technicians can be improved considerably by requiring interaction with the elements and layout of a circuit diagram prior to the initiation of a solution sequence. This finding should help in providing guidelines for training technicians to better understand and troubleshoot equipment.

7. REFERENCES

- Adelson, B. When novices surpass experts: The difficulty of a task may increase with expertise. Journal of Experimental Psychology: Learning, Memory, and Cognition, 1984, 10, 483-495.
- Anderson, J.R. Language, Memory and Thought. Hillsdale, N.J.: Erlbaum 1976.
- Anderson, J.R., & Bower, G.H. Human Associative Memory. Washington, D.C.: Winston, 1973.
- Atwood, M.E. & Polson, P.G. A process model for waterjug problems. Cognitive Psychology, 1976, 8, 191-216.
- Badre, A.N. Selecting and Representing Information Structures for Battlefield Decision Systems (Report No. TR-79-A20). Alexandria, Virginia: U.S. Army Research Institute for the Behavioral and Social Sciences, June 1979.
- Bond, N.A., & Towne, D.M. Troubleshooting Complex Equipment in the Military Services: Research and Prospects (Technical Report 92). Los Angeles: University of Southern California, Behavioral Technology Laboratories. December, 1979.
- Bhaskar, R., & Simon, H.A. Problem Solving in Semantically Rich Domain: An Example from Engineering Thermodynamics. Cognitive Science, 1977, 1, 139-215.
- Brown, J.S., Collins, A., & Harris, G. Artificial Intelligence and Learning Strategies. In H.F. O'Neil, Jr. (Ed.), Learning Strategies. New York: Academic Press, 1978.
- Chase, W.g., & Simon, H.A. Perception in Chess. Cognitive Psychology, 1973, 4, 55-81.
- Chi, M., Feltovich, P., & Glaser, R. Physics Problem Solving by Experts and Novices. Paper presented at the Twentieth Annual Meeting of the Psychonomic Society, Phoenix, November 1979.
- Collins, A.M. & Loftus, E.G. A Spreading-Activation Theory of Semantic Processing. Psychological Review, 1975, 82, 407-428.
- Cooper, L.A. Mental Transformation of Random Two-Dimensional Shapes. Cognitive Psychology, 1975, 7, 20-43.

DeGroot, A.D. Perception and Memory Versus Thought: Some Old Ideas and Recent Findings. In B. Kleinmuntz (Ed.), Problem Solving: Research, Method, and Theory. New York: Wiley, 1966.

DeKleer, J. Causal and Teleological Reasoning in Circuit Recognition (AR-TR-529). Cambridge, Massachusetts: Artificial Intelligence Laboratory, Massachusetts Institute of Technology, September 1979.

DeKleer, J., & Brown, J.S. Mental models of Physical Mechanisms and Their Acquisition. Unpublished manuscript, 1980. (Available from XEROX PARC, Cognitive and Institutional Sciences, 3333 Coyote Hill Road, Palo Alto, California, 93404.)

Egan, D.E., & Schwartz, B.J. Chunking in Recall of Symbolic Drawings. Memory and Cognition, 1979, 7, 149-158.

Freedy, A., & Crooks, W.H. Use of an Adaptive Decision Model in Computer Assisted Training of Troubleshooting. Proceedings of the Conference on New Concepts in Maintenance Training, Orlando, FL, April 1975.

Greeno, J.G. Natures of Problem-Solving Abilities. In W.K. Estes (Ed.), Handbook of Learning and Cognitive Processes. Volume 5: Human Information Processing. Hillsdale, New Jersey: Erlbaum, 1978.

Johnson, C.S. Hierarchical Clustering Schemes. Psychometrika, 1967, 32, 241-254.

Kosslyn, S.M. Information Representation in Visual Images. Cognitive Psychology, 1975, 7, 341-370.

Larkin, J.H. Expertise and Solution Strategies for Textbook Physics Problems. Paper presented at the Twentieth Annual Meeting of the Psychonomic Society, Phoenix, November 1979.

Larkin, J.H. McDermott, J., Simon, D.P. & Simon, H.A. Models of Competence in Solving Physics Problems. Cognitive Science, 1980, 4, 317-345.

Miller, G.A. A Psychological Method to Investigate Verbal Concepts. Journal of Mathematical Psychology, 1969, 6, 169-191.

Newell, A., & Simon, H.A. Human Problem Solving. Englewood Cliffs, NJ: Prentice-Hall, 1972.

Norman, D.A., & Rumelhart, D.E. (Eds.) Explorations in Cognition. San Francisco: W.H. Freeman, 1975.

Reitman, J. Skilled Perception in Go: Deducing Memory Structures from Inter-Response Times. Cognitive Psychology, 1976, 6, 336-356.

Reitman, J.S., McKeithen, K.B., Reuter, H.R., & Hirtle, S. Knowledge Organization of Expert and Novice Programmers. Paper presented at the Twentieth Annual Meeting of the Psychonomic Society, Phoenix, November 1979.

Rouse, W.B. Human Problem Solving Performance in a Fault Diagnosis Task. IEEE Transactions on Systems, Man, and Cybernetics, 1978, SMC-8, 258-271.

Samet, M.G., & Geiselman, R.E. Developing Guidelines for Summarizing Information. Human Factors, 1981, 23, 727-736.

Sattath, S., & Tversky, A. Additive Similarity Trees. Psychometrika, 1977, 42, 319-345.

Schank, R.C. Conceptual Dependency: A Theory of Natural Language Understanding. Cognitive Psychology, 1972, 3, 552-631.

Shepard, R.N. The Mental Image. American Psychologist, 1978, 33, 125-137.

Shepard, R.N., & Arabie, P. Additive Clustering: Representation of Similarities as Combinations of Discrete Overlapping Properties. Psychological Review, 1979, 86, 87-123.

Simon, H.A. The architecture of complexity. In H.A. Simon (ed.), The Sciences of the Artificial. Cambridge, Mass: M.I.T. Press, 1969.

Simon, H.A., & Chase, W.G. Skill in Chess. American Scientist, 1973, 61, 394-403.

Simon, H.A., & Gilmarin, K. A Simulation of Memory for Chess Positions. Cognitive Psychology, 1973, 5, 29-46.

Stevens, A.L., & Collins, A. Multiple Models of a Complex System. In R. Snow, P. Federico, & W. Montague (Eds.) Aptitude, Learning, and Instruction: Cognitive Processing Analysis. Hillsdale, N.J.: Erlbaum, 1980.

Wallas, G. The art of thought. New York: Harcourt, Brace, Jovanich, 1926.

Wickens, T.D. Models for Behavior: Stochastic Processes in Psychology. San Francisco: W.H. Freeman, 1982.

Winograd, T. A Program for Understanding Natural Language. Cognitive Psychology, 1972, 3, 1-191.

END

FILMED

1-86

DTIC