

AD-A161 652

PERFORMANCE COMBUSTION CHARACTERISTICS AND EXHAUST
EMISSION OF A DIRECT I (U) NORTH CAROLINA STATE UNIV
AT RALEIGH E M AFIFY 30 SEP 85 ARO-19435 3-EG

1/2

UNCLASSIFIED

DAR229-83-K-0015

F/G 21/7

ML

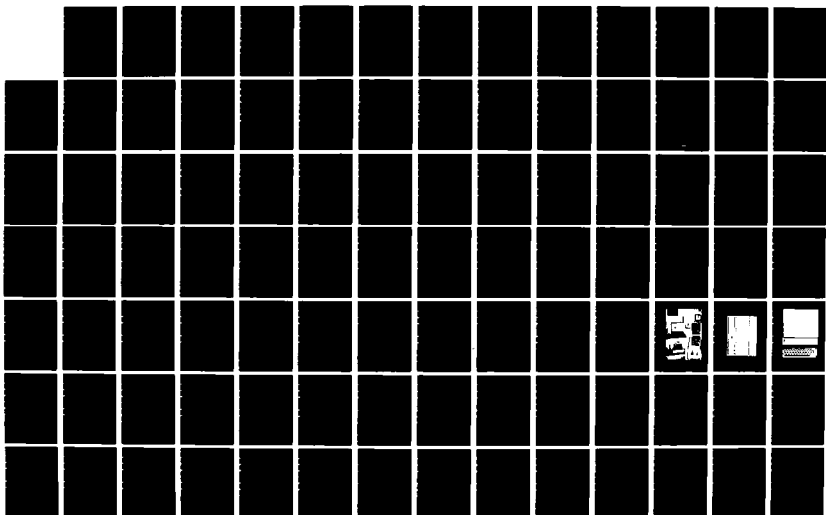

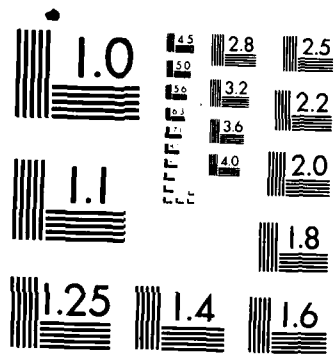

MICROCOPY RESOLUTION TEST CHART
NATIONAL BUREAU OF STANDARDS-1963-A

SECURITY

AD-A161 652

D
E

2

READ INSTRUCTIONS BEFORE COMPLETING FORM	
1. REP <i>ARO 19435.3-EG</i>	3. RECIPIENT'S CATALOG NUMBER
4. TITLE (and Subtitle) Performance Combustion Characteristics and Exhaust Emission of a Direct Injection Diesel Engine Using Water/Oil Emulsions as Fuel	5. TYPE OF REPORT & PERIOD COVERED Final <i>15 Jan 83 - 30 Jun 85</i>
7. AUTHOR(s) E. M. Afify	6. PERFORMING ORG. REPORT NUMBER
9. PERFORMING ORGANIZATION NAME AND ADDRESS North Carolina State University	8. CONTRACT OR GRANT NUMBER(s) DAA G29-83-K-0015
11. CONTROLLING OFFICE NAME AND ADDRESS U. S. Army Research Office Post Office Box 12211 Research Triangle Park, NC 27709	10. PROGRAM ELEMENT, PROJECT, TASK AREA & WORK UNIT NUMBERS
14. MONITORING AGENCY NAME & ADDRESS (if different from Controlling Office)	12. REPORT DATE September 30, 1985
	13. NUMBER OF PAGES 94 pages
	15. SECURITY CLASS. (of this report) Unclassified
	15a. DECLASSIFICATION/DOWNGRADING SCHEDULE
16. DISTRIBUTION STATEMENT (of this Report) Approved for public release; distribution	
17. DISTRIBUTION STATEMENT (of the abstract entered in Block 20, if different from Report) N/A	
18. SUPPLEMENTARY NOTES To be published in "Combustion and Flame". THE VIEW, OPINIONS, AND/OR FINDINGS CONTAINED IN THIS REPORT ARE THOSE OF THE AUTHOR(S) AND SHOULD NOT BE CONSTRUED AS AN OFFICIAL DEPARTMENT OF THE ARMY POSITION, POLICY, OR DECISION, UNLESS SO DESIGNATED BY OTHER DOCUMENTATION.	
19. KEY WORDS (Continue on reverse side if necessary and identify by block number) Diesel Engines, Combustion, Performance, Exhaust Emissions, Water/Oil Emulsions.	
20. ABSTRACT (Continue on reverse side if necessary and identify by block number) A CLR single cylinder diesel engine is used to determine the effect of air content in the emulsified fuel on the performance, exhaust emissions and ignition delay of diesel engines. The experiments were conducted using diesel fuel #2 and JP-4 as baseline fuels and emulsions containing 15%, 30% and 45% water by volume. The air charge temperature was varied from 88°F to 302°F. The effects associated with use of	

DTIC
ELECTE
SEP 25 1985

DTIC FILE COPY

DD FORM 1473 1 JAN 73 EDITION OF 1 NOV 63 IS OBSOLETE

SECURITY CLASSIFICATION OF THIS PAGE (When Data Entered)

the emulsions on performance, ignition delay and exhaust emissions were determined by making detailed measurements of fuel consumption, engine operating parameters and exhaust emissions.

The results showed that slight improvement in BSFC was observed when emulsions with low water content were used at high speeds. For high water content emulsions, the BSFC increased. Heating the intake air increased the BSFC at high engine loads and slightly improved it at low engine loads. While the ignition delay was found to increase with the increase of the water percentage in the emulsion, preheating the air charge was effective in reducing it. Although, NO_x and soot formation were reduced effectively with the increase of water content in the emulsion, preheating the air charge adversely affected NO_x and soot emissions. While CO and VHC emissions increased with the increase of the water content in the emulsion, increasing the intake air temperature slightly reduced CO and VHC at low loads.

(carbon monoxide and
unburned hydrocarbons)

copy in ...
...
Water ...

Table of Contents

	<u>Page</u>
List of Tables.	i
List of Figures.	ii
List of Symbols and Abbreviations.	iii
Chapter I Statement of the Problem.	1
Introduction	
Background	
Objectives	
Chapter II Description of the Experimental Apparatus.	5
Intake Air System and Instrumentation	
Fuel Flow Measurement System	
Combustion Instrumentation	
Load Measurement Instrumentation	
Engine Speed Measurement Instrumentation	
Temperature Measurement Instrumentation	
Barometric Pressure Measurement Instrumentation	
Exhaust Smoke Opacity Monitor	
Exhaust Emission Instrumentation	
Chapter III Test Procedure.12
Engine Test Procedure	
Calibration Procedure for the Exhaust	
Smoke Opacity Monitor	
Emulsified Fuel Mixing Procedure	
Chapter IV Data Analysis.16
Data Reduction	
Chapter V Summary of the Most Important Results.17
Summary of the Results	
Recommendations for Further Research	
References.20

Appendices

A. Engine Specifications.	22
B. Engine Input Parameters.	24
C. Engine Output Parameters.	25
D. Smoke Opacity Monitor Calibration Curve.	26
E. Properties of Diesel Fuel #2.	27
F. Properties of JP4 Fuel.	29
G. Data Reduction Program.	30
H. Details of Calculations.	32

LIST OF FIGURES

		<u>Page</u>
Figure 1	Schematic of Engine Intake, Exhaust and Emission Systems.	51
Figure 2	Schematic of the Fuel Delivery System.	52
Figure 3	Schematic of the Combustion Instrumentation.	53
Figure 4	Photograph of the Combustion Instrumentation.	54
Figure 5	Photograph of the Cylinder Pressure, Needle Lift, Fuel Pressure and Degrees Crank Angle Signals on the Tektronix Oscilloscope.	55
Figure 6	Photograph of the Needle Lift and Cylinder Pressure Digitized Signals on the Screen.	56
Figure 7	IBM PC Computer Plot of the Cylinder Pressure and Needle Lift Signals.	57
Figure 8	Schematic of the Smoke Opacity Monitor.	58
Figure 9	Flow Chart of Testing Procedure.	59
Figure 10	Effect of Water/Oil Emulsions on the BSFC for an Intake Air Temperature of 88°F at 2000 RPM.	60
Figure 11	Effect of Water/Oil Emulsions on the BSFC for an Intake Air Temperature of 88°F at 1000 RPM.	61
Figure 12	Effect of Engine Load and Intake Air Temperature on the Volumetric Efficiency for Neat Diesel Fuel #2 at 1000 RPM.	62
Figure 13	Effect of Engine Load and Intake Air Temperature on the Volumetric Efficiency for Neat Diesel Fuel #2 at 2000 RPM.	63
Figure 14	Effect of Engine Load and Intake Air Temperature on the BSFC for Neat Diesel Fuel #2 at 1000 RPM.	64
Figure 15	Effect of Engine Load and Intake Air Temperature on the BSFC for 15% Water/Oil Emulsion at 1000 RPM.	65
Figure 16	Effect of Engine Load and Intake Air Temperature on BSFC for 30% Water/Oil Emulsion at 1000 RPM.	66

LIST OF FIGURES (continued)

	<u>Page</u>
Figure 17 Effect of Engine Load and Intake Air Temperature on the BSFC for 45% Water/Oil Emulsion at 1000 RPM.	67
Figure 18 Effect of Engine Load and Intake Air Temperature for Neat Diesel Fuel #2 at 2000 RPM.	68
Figure 19 Effect of Engine Load and Intake Air Temperature on the BSFC for 15% Water/Oil Emulsion at 2000 RPM.	69
Figure 20 Effect of Engine Load and Intake Air Temperature on the BSFC for 30% Water/Oil Emulsion at 2000 RPM.	70
Figure 21 Effect of Engine Load and Intake Air Temperature on the BSFC for 45% Water/Oil Emulsion at 2000 RPM.	71
Figure 22 Effect of Water/Oil Emulsion on the Ignition Delay Period for an Intake Air Temperature of 167°F at 1000 RPM.	72
Figure 23 Effect of Engine Load and Intake Air Temperature on the Ignition Delay Period for Diesel Fuel #2 at 1000 RPM.	73
Figure 24 Effect of Engine Load and Intake Air Temperature on the Ignition Delay for 15% Water/Oil Emulsion at 1000 RPM.	74
Figure 25 Effect of Engine Load and Intake Air Temperature on the Ignition Delay Period for 30% Water/Oil Emulsion at 1000 RPM.	75
Figure 26 Effect of Engine Load and Intake Air Temperature on the Ignition Delay Period for 45% Water/Oil Emulsion at 1000 RPM.	76
Figure 27 Effect of Water/Oil Emulsions on the Ignition Delay Period for an Intake Air Temperature of 167°F at 2000 RPM.	77
Figure 28 Effect of Engine Load and Intake Air Temperature on the BSFC of Neat JP4 Fuel at 2000 RPM.	78
Figure 29 Effect on Engine Load and Intake Air Temperature on the BSFC for 15% Water/JP4 Emulsion at 2000 RPM.	79

LIST OF FIGURES (continued)

	<u>Page</u>
Figure 30 Effect of Engine Load and Intake Air Temperature on the BSFC for 30% Water/JP4 Emulsion at 2000 RPM.	80
Figure 31 Effect of Engine Load and Intake Air Temperature on the Ignition Delay Period for Neat JP4 at 2000 RPM.	81
Figure 32 Effect of Engine Load and Intake Air Temperature on the Ignition Delay Period for 15% Water/JP4 Emulsion at 2000 RPM.	82
Figure 33 Effect of Engine Load and Intake Air Temperature on the Egnition Delay Period for 30% W/JP4 Emulsion at 2000 RPM.	83
Figure 34 Effect of Water/JP4 Emulsion on the Ignition Delay Period for Ambient Intake Air Temperature at 2000 RPM	84
Figure 35 Effect of Water/Oil Emulsions and Intake Air Temperature on the Exhaust Gas Opacity for BMEP = 63 psi at 1000 RPM.	85
Figure 36 Effect of Water/Oil Emulsions and Intake Air Temperature on the Exhaust Gas Opacity for BMEP = 63 at 2000 RPM.	86
Figure 37 Effect of Engine Load and Intake Air Temperature on Nox Emission for Neat Diesel Fuel #2 at 2000 RPM.	87
Figure 38 Effect of Engine Load and Water/Diesel Emulsion on Nox Emission at Ambient Intake Air Temperature and 2000 RPM.	88
Figure 39 Effect of Engine Load and Intake Air Temperature on CO Emission for Neat Diesel Fuel #2 at 2000 RPM.	89
Figure 40 Effect of Engine Load and Intake Air Temperature on CO Emission for W/Diesel Emulsion at 2000 RPM.	90
Figure 41 Effect of Engine Load and Intake Air on CO Emission for 30% W/Diesel at 2000 RPM.	91

LIST OF FIGURES (continued)

	<u>Page</u>
Figure 42 Effect of Engine Load and Intake Air Temperature on CO Emission for 45% Emulsion at 2000 RPM.	92
Figure 43 Effect of Engine Load and Water/Diesel Emulsion at 167°F Intake Air Temperature and 2000 RPM on UHC Emissions.93
Figure 44 Effect of Engine Load and Intake Air Temperature on UHC Emission for Diesel Fuel #2 at 1000 RPM.	94

LIST OF SYMOBLS AND ABBREVIATIONS

ABDC	after bottom dead center
A/D	analog to digital converter
AF	air fuel ratio
AMBT	ambient air temperature
ATDC	after top dead center
BHP	brake horsepower
BTDC	before top dead center
BMEP	brake mean effective pressure
BP	barometric pressure
BSFC	brake specific fuel consumption
C	constant
C.BHP	corrected brake horsepower
CA	crank angle
CFM	cubic feet per minute
CFT	temperature correction factor
CP(I)	cylinder pressure amplitude
CYLVOL	cylinder volume
D	day
DENAIR	density of air
DENDF	density of diesel fuel
DENSUR	density of surfactant
DENW	density of water
DI	direct injection
EM	percent water in emulsion
E.TEMP	exhaust gas temperature
EQMF	equivalent mass flow rate of fuel
EVO	exhaust valve opens
EVC	exhaust valve closes
F	force on dynamometer load cell
FC	mass of fuel consumed
HLB	hydrophile lipophile balance
HVDF	heating value of diesel fuel
HVSUR	heating value of surfactant
I	number of tests per data set

ID	ignition delay period
INJ	fuel injection timing
IVC	intake valve closes
IVO	intake valve opens
LBF	pounds force
LBM	pounds mass
LEVER	dynamometer lever arm length
M	month
MA	mass flow rate of air
MDF	mass flow rate of diesel fuel
MF	mass flow rate of total fuel
MTH	theoretical mass of air that fills the engine cylinder each cycle at atmospheric conditions
MSUR	mass flow rate of surfactant
N	engine speed
NL(I)	needle lift amplitude
NUM	number of data sets
OP	exhaust smoke opacity
PCF	pressure correction factor for HP calculation
PD	pressure drop across the meriam laminar flow element
PSI	pounds per square inch
RAIR	ideal gas constant for air
RFG	rotational function generator
SCP(I)	slope of the cylinder pressure curve
SNL(I)	slope of the needle lift curve
SMNO	value of smoke opacity monitor output (microamperes)
T	time to consume 100 grams of fuel
TCF	temperature correction factor for horsepower calculation
TEMPI	intake air temperature
V.EFF	volumetric efficiency
X	volume flow rate of diesel fuel
XS	volume flow rate of surfactant
Y	total fuel flow rate
YE	year
Z	composite fuel density

LIST OF PUBLICATIONS

Portions of this study is now in preparation for publication in "Combustion and Flame".

LIST OF PARTICIPATING SCIENTIFIC PERSONNEL

Daniel Dickey	M.S.	earned in June 1985
Nader Korah	Ph.D.	still in progress
Quano Jeny	Ph.D.	still in progress

CHAPTER I
STATEMENT OF THE PROBLEM

Introduction

Experimental studies by several investigators [1-12] on the potential use of water/fuel emulsions as diesel engine fuel showed promising results.

Valdmanis and Wulfhorst [1] working on a single cylinder D.I. diesel engine found significant reductions in NO_x and smoke emissions when water/fuel emulsions were used. They also indicated that as the concentration of water in the emulsion was increased, the ignition delay increased. To compensate for that, they advanced the ignition timing which adversely affected the NO_x emission. Coon and Storum [2] working on a single cylinder CLR engine and using unstabilized water/fuel emulsions with water content varying from 2 percent to 23 percent by volume, reported a significant reduction in NO_x emissions and exhaust smoke density. Increases in unburned HC and CO concentration were also encountered depending on speed, load and water content of the fuel. They also performed limited analysis of the effect of emulsified fuel on the ignition delay and best power timing of the engine. Their results did not show drastic changes in ignition delay with the increase of water content of the fuel. This may be attributed to the low percentage of water content used as compared to that used by Valdmanis and Wulfhorst [1]. Cook and Law [3] studied the effect of water/fuel emulsion on IMEP and particulate emission of a single cylinder diesel engine. Their results showed that with equal amount of fuel injection the IMEP was minimally affected with water addition. They also indicated that smoke emission was reduced when water content in the emulsion ranged between 10 percent and 20 percent by volume. However, excessive water addition was found to

outweigh this beneficial effect. They attributed this to the prolonged ignition delay at higher levels of water content in the emulsion. Crookes, et al. [4] studied the combustion of water/diesel fuel emulsions. Their results using a single cylinder 4-stroke diesel engine showed significant reduction in NO_x emission. A reduction in CO, unburned HC and soot concentrations were also obtained with increase in water content of the fuel up to a critical value.

In summary, most of the work performed on the use of water/fuel emulsions in diesel engines, to a great extent, showed improvements in NO_x and soot emission characteristics of the engine and indicated also that an increase in the water content in the emulsion prolonged the ignition delay which can adversely affect engine performance. It is the purpose of this investigation to study the use of water/oil emulsions in diesel engines and their effect on ignition delay, engine performance and exhaust emissions.

Background

Research work on the ignition delay of neat hydrocarbon fuels has been carried by many investigators. Henein [13] gave an excellent review on the ignition delay in diesel engines. Henein and Bolt [14] studied the effect of fuel/air ratio, injection pressure, coolant temperature and turbulence on the ignition delay in diesel engines. They reported that increase in cylinder air pressure, fuel/air ratio, cooling water temperature and engine speed shortened the delay period. They also showed later [15] that increasing the air charge temperature was very effective in reducing the ignition delay for several fuels including gasoline. Hiroyasu [16] studied

the autoignition of fuel sprays in a constant volume bomb. He found that the ignition delay was primarily affected by the air temperature, pressure and oxygen concentration, all of which affect the rate of chemical reactions. Gelalles [17], Gerrish and Ayers [18], and Pediani [19] studied the effect of preheating neat diesel fuels on the combustion and soot formation in diesel engines. Their results indicated that, in general, an increase in fuel temperature reduced the ignition delay and soot emissions, provided smoother combustion and finer atomization of spray but with reduced penetration. Recent studies on the preheating of the fuel [20-22] showed that only fuel temperatures near their critical temperatures were effective in reducing the ignition delay. Unfortunately, at such temperature levels water separation and emulsion instabilities were found to occur [7].

In conclusion, it is noted that the major parameters which affect the ignition delay in diesel engines using neat hydrocarbon fuels are the air charge temperature, the preinjection fuel temperature, type of fuel, load and speed. It is the objective of this investigation to study parametrically the effect of above parameters on the ignition delay in diesel engines using water/fuel emulsions.

Objectives

It is the objective of this investigation to study parametrically the effect of the following:

1. The air charge temperature
2. The preinjection emulsified fuel temperature
3. Engine speed and load

4. Percentage of water content in the emulsified fuel
5. Type of fuel

on the ignition delay, performance and emissions in diesel engines.

CHAPTER II

THE EXPERIMENTAL APPARATUS

A CLR direct injection research diesel engine manufactured by Laboratory Equipment Company is used for this investigation. A complete list of engine specifications is given in Appendix A. The engine is coupled to an Eaton Dynamatic eddy--current dynamometer equipped with controls to regulate the engine speed and load.

The top end of the engine was completely rebuilt before engine tests were begun. The cylinder liner, piston rings, and head gasket, were replaced with new ones. The valve seats were also reconditioned and after the engine was reassembled the valve timing was checked to make sure it met new engine specifications.

Engine Systems and Instrumentation

Figures 1-4 show schematics of the engine systems and instrumentation. Appendices B and C lists the range and precision of each instrument.

Intake Air System and Instrumentation

The intake air system consists of an air filter, an air flow meter, and a surge tank which contains heating elements to heat the intake air. The surge tank and intake air plumbing leading to the engine are insulated with a 1/2 inch layer of Smooth Kote insulation.

Intake Air Flow Meter

The intake air flow is measured using a Meriam Laminar Flow Element. The air flow meter is connected to the intake system before the surge tank

as shown in Figure 1. An automotive type air filter is connected to the other end of the flow meter to filter the incoming air.

The pressure drop across the flow meter is measured using an Ashcroft bourdon tube type pressure gauge.

Intake Air Heater and Controls

The intake air heater shown in Figure 1 is constructed by mounting four 1500-watt oven-type heating elements in the intake air surge tank. An Omega temperature Controller (model 1622) is used to regulate the intake air temperature by controlling the amount of power delivered to the heating elements. The temperature controller receives information from a thermocouple mounted in the intake air manifold.

Fuel Flow Measurement System

Figure 2 shows the fuel flow measurement system. A Fisher Ainsworth LC-1000 Digital Balance is used to measure the mass of fuel consumed. A Standard electric stop clock activated by a toggle switch measures the time required to consume a specified mass of fuel.

Combustion Instrumentation

Figures 3 and 5 show a schematic and a photograph of the combustion instrumentation while Figure 6 shows a typical oscilloscope display of the cylinder pressure, needle lift, fuel pressure, and degrees crank angle signals. The following transducers and signal processors/analyzers are used:

Cylinder Pressure Transducer. A Kistler piezoelectric pressure transducer (model 6121) is flush-mounted in the cylinder head. A Krag-Swiss type

5002 dual charge amplifier is used to convert the charge from the piezoelectric transducer into a voltage signal. This voltage signal is connected to channel four of the oscilloscope and channel one of the Labmaster A/D converter.

Needle Lift Transducer. A Bently-Nevada proximity probe (type 190) is mounted on top of the fuel injector. The probe is connected to a model 3000 proximeter which uses a separate 18-volt power supply and outputs a voltage signal proportional to the displacement of the fuel injector needle. A DC offset amplifier is used to bring the needle lift voltage signal down to ground level. A Sanborn Differential Amplifier (model 8875A) amplifies this signal before it is sent to channel two of the Labmaster A/D converter and channel three of the oscilloscope.

Fuel Pressure Transducer. A Kistler pressure transducer (model 603B) is mounted on the fuel line between the fuel pump and the fuel injector. A charge amplifier built into channel one of the oscilloscopes 3A74 Engine Analyzer Amplifier converts this charge signal into a voltage signal so it can be displayed on the oscilloscope.

Top Dead Center Transducer. A magnetic transducer is mounted near the crankshaft. A thin piece of metal attached to the crankshaft passes by the magnetic transducer when the piston is in the TDC position. The signal from the magnetic transducer is sent to channel two of the oscilloscope.

Degrees Crank Angle Transducer. A Tektronix Rotational Function Generator is connected to one end of the engine crankshaft as shown in Figure 3. The signal from this generator is sent to the oscilloscopes 2B67 Engine

Analyzer Time Base module. The RFG produces small voltage spikes every ten degrees CA, larger spikes every 60 seconds CA, and one large spike at TDC. The signal from the magnetic TDC transducer is aligned with the TDC spike from the RFG to provide a meaningful time base for the oscilloscope which displays the engine cycle in degrees CA.

Oscilloscope. A Tektronix Type 564B Storage Oscilloscope is employed to display the signals from the combustion instrumentation transducers. The scope uses a four-channel Tektronix 3A74 Engine Analyzer module to amplify the cylinder pressure, needle lift, fuel pressure, and TDC transducer signals. A Tektronix 2B67 Engine Analyzer Time Base is used to accept the RFG signal. Photographs of the oscilloscope traces are taken with a Tektronix model C-27 oscilloscope camera.

Analog to Digital Converter. A Labmaster analog to digital converter is used to digitize the cylinder pressure and needle lift analog signals. The sampling frequency using two channels is 12.5 KHZ. Five hundred data points are collected per sample per channel yielding a resolution of 0.08 milliseconds per data point. The digitized cylinder pressure and needle lift signals are shown in Figure 7.

Computer System. An IBM Personal Computer is used to store data files containing samples of the needle lift and cylinder pressure digitized signals.

Input parameters for the data acquisition software are selected from an Amdek Video-300 graphics monitor using an FTG Data Lite Pen. An Epsom graphics printer prints out plots of the cylinder pressure and needle lift signals versus time (see Figure 7).

Load Measurement Instrumentation

An Emory hydraulic load cell measures the force transmitted from the dynamometer lever arm. A Heise bourdon tube type pressure gauge measures this hydraulic pressure and indicates the force on the load cell in pounds.

Engine Speed Measurement Instrumentation

The engine speed is measured using a magnetic pickup connected to a Standard electronic tachometer. The magnetic pickup is mounted next to a toothed-gear driven by the engine crankshaft.

Temperature Measurement Instrumentation

Thermocouples are used to measure the inlet and outlet cylinder head coolant temperature, the oil sump temperature, and the intake air temperature before the air flow meter. An Emory pyrometer is used to select the output from these thermocouples and indicate the temperature in degrees Fahrenheit.

The exhaust gas temperature is measured using a type K kromel--alumel thermocouple inserted in the exhaust manifold. An Omega thermocouple thermometer (model 660) measures the output from this thermocouple and indicates the exhaust gas temperature in degrees Celsius.

The intake air temperature just before the air enters the engine is measured using an Omega iron--constantan thermocouple. This thermocouple is connected to the Omega temperature controller (model 1622) which regulates the intake air temperature.

The ambient wet and dry bulb temperatures are measured using Taylor mercury in glass thermometers.

Barometric Pressure Measurement Instrumentation

The barometric pressure is measured using a Fisher Scientific mercury barometer.

Exhaust Smoke Opacity Monitor

The smoke opacity monitor shown in Figure 8 is mounted on the exhaust pipe to measure the opacity of the exhaust gases. A Beam of light is projected through the exhaust gas and is detected by a photo cell on the other side of the exhaust pipe. The smoke opacity monitor is equipped with removable slides which keeps the exhaust gases from entering the monitor when it is not in use. Air purge inlets on each end of the monitor allow compressed air to flow over the glass lenses to keep exhaust soot from collecting on the lenses while opacity readings are being taken. The glass lenses are also retractable for easy cleaning.

A Simpson DC microammeter is used to measure the output current from the photo cell.

Exhaust Emission Instrumentation

The exhaust emissions from the test engine are measured using the following instrumentation:

1. NO_x concentration is measured using a Scott chemiluminescence analyzer . (Model 125)
2. CO and CO_2 concentration is measured using Beckman and nondispersive infrared analyzers (model 315A, 315B).

3. Unburned hydrocarbon concentration is measured with an FID Beckman total hydrocarbon analyzer (Model 402).

A schematic of the instrumentation and the exhaust emission flow diagram is shown in Figure 1 .

CHAPTER III
TEST PROCEDURE

Engine Test Procedure

All performance tests are conducted in accordance with SAE J1349, the engine power test code for spark ignition and diesel engines. Any deviations from the test code are noted in the text.

Two neat fuels (diesel fuel #2 and JP-4) provided by the U. S. Army Fuels and Lubricant Research Laboratory are used in this investigation. Emulsified fuels having 15, 30, and 45 percent water content are also prepared for testing. The tests are conducted at engine speeds of 1000, 1500, and 2000 RPM at five engine loads (6, 9, 12, 15 and 18 foot pounds) and at three separate intake air temperatures of ambient, 167 and 302 degrees Fahrenheit. The ambient temperature varies from 79 to 88°F.

To begin each test session, the engine is started on neat fuel and warmed up at the first test speed. The warm up period ends when the oil sump temperature reaches equilibrium. If the intake air is heated for the first test the temperature controller is set to the desired preheat temperature. The first test fuel is then selected. If emulsions are used the new fuel is introduced into the fuel lines and another period of time is allowed for the engine to stabilize. The fuel injection timing and rack setting are adjusted iteratively until optimum performance is obtained at the first load setting. A data sheet is then recorded with the following information: engine speed, engine load, intake air preheat temperature, inlet and outlet coolant temperatures, oil sump temperature, exhaust gas temperature, wet and dry bulb room temperatures, barometric pressure, oil

pressure, the pressure drop across the laminar flow element, fuel injection timing, rack setting, smoke opacity monitor reading, exhaust emission readings, and the fuel consumption time. A photo is taken of the oscilloscope screen which simultaneously displays the cylinder pressure, injector needle lift, fuel pressure, and degree crank angle signals. Two ignition delay period measurements are taken and stored in the IBM Personal Computer. The load is then increased to the next test value and the injection timing is again adjusted to obtain maximum performance. After the engine stabilizes another line of the data sheet is recorded. After all five load settings are tested the intake air preheat temperature, fuel type, and engine speed are changed in that order. See Figure 9 for a flow chart of the entire engine test program.

The general procedure then is to operate the engine on neat fuel at 1000 RPM for the five different loads and three separate intake air temperatures. Each temperature increase is followed by the five load settings. This sequence is repeated for the emulsified fuels containing 15, 30, and 45 percent water. The entire process is then repeated for the 1500 and 2000 RPM engine speeds.

Specific engine tests are repeated so a statistical analysis can be conducted on the data. Engine tests are repeated at 1000 and 2000 RPM for the three highest test loads of 12, 15, and 18 foot pounds using an intake air temperature of 88 degrees Fahrenheit. Fuels containing 0, 15, and 30 percent water are compared at these conditions to investigate the effect of increasing the water content in the fuel on the BSFC. Engine tests using 45 percent water/oil emulsion are not repeated due to the severe engine knock encountered during previous engine tests.

Calibration Procedure for the Exhaust Smoke Opacity Monitor

The exhaust smoke opacity monitor is calibrated using six light filters with optical densities of 0.10, 0.30, 0.40, 0.70, 1.00, and 2.00. The light source is first turned on and the gain is adjusted until the micro-ammeter reads 50 micro-amps. Each of the six filters is then placed between the light source and the photoelectric cell. The micro-ammeter is read after each filter is used. An equation which relates the optical density to opacity is then employed to determine the opacity corresponding to each filter:

$$\text{Optical Density} = \log \frac{1}{1 - \text{Opacity}} .$$

A calibration curve (given in Appendix D) is then plotted to show the relationship between the micro-ammeter reading and the exhaust smoke opacity. The method of least squares is used to determine the equation of the straight line passing through the data points.

Emulsified Fuel Mixing Procedure

The water/oil emulsions are prepared by mixing the neat fuel and a constant 2 percent surfactant with 15, 30, and 45 percent deionized distilled water by volume as shown in Table I. The volumes of neat fuel, water, and surfactant are measured using graduated cylinders. The properties of #2 diesel fuel and JP-4 fuel are given in Appendices E and F.

The neat fuel and surfactant are first mixed together for two minutes. The water is then added and the emulsion is blended for another ten minutes. All emulsions are prepared just before each engine test using emulsified fuels.

The surfactant is prepared by mixing Span 80 (Sorbitan Monooleate HLB = 4.3) and Tween 85 (Polyoxyethylene (20) Sorbitan Trioleate HLB = 11.0) in a 3:1 mass ratio. These surfactants are purchased from ICI Chemicals, Inc., Wilmington, Delaware.

TABLE I
FUEL COMPOSITION FOR EMULSIONS

<u>Emulsion Type</u>	<u>Diesel Fuel Volume</u>	<u>Water Volume</u>	<u>Surfactant Volume</u>
15%	830 ml	150 ml	20 ml
30%	680 ml	300 ml	20 ml
45%	530 ml	450 ml	20 ml

Procedure for Determining the Fuel Heat of Combustion

The heat of combustion for the surfactant mixture used in this investigation is determined using a Parr Oxygen Calorimeter. The heat of combustion for pure diesel fuel #2 is also determined using this same calorimeter so the two heats of combustion will have the same reference base. (The heat of combustion for pure #2 diesel fuel calculated using this calorimeter differs by only 0.5% from the published net heat of combustion found in Appendix E.) These calculated heats of combustion for the surfactant and diesel fuel #2 are used in the data reduction program.

CHAPTER IV
DATA ANALYSIS

Data Reduction

Performance parameters are calculated to convert the test data into a more useful form. Values for the engine speed, load exerted on the dynamometer lever arm, mass of fuel consumed, time to consume the fuel, intake and ambient air temperatures, percent water in the fuel, pressure drop across the air flow meter, temperature correction factor for the air flow meter, barometric pressure, smoke number, exhaust gas temperature, fuel injection timing, and ignition delay period are taken from the engine data sheet and read into a computer program. The program performs all calculations in accordance with SAE J1349 and outputs values for the load exerted on the load cell, air and fuel flow rates, air fuel ratio, corrected brake horsepower, brake mean effective pressure, brake specific fuel consumption, fuel injection timing, ignition delay period, volumetric efficiency, exhaust gas temperature, and the smoke opacity. A copy of the data reduction program can be found in Appendix G. The output of this program for 1000 and 2000 RPM is given in Table III. Details of the calculations are given in Appendix H.

CHAPTER V

SUMMARY OF THE MOST IMPORTANT RESULTS

Summary of the Results

The results of this investigations can be summarized as follows:

1. Slight improvement in BSFC is noticed when w/diesel fuel emulsions are used as fuel. Higher water content in the emulsion will cause an increase in BSFC, while smaller water content will not significantly improve the BSFC of the engine.
Statistically established BSFC results at 2000 RPM and 88°F ambient temperature show that adding 15 and 30 percent water to diesel fuel decrease the BSFC by an average of 2.54 and 1.92 percent respectively. A maximum decrease of 3.57 percent is obtained using 15 percent w/o emulsion (see Table II and Figure 10).
2. At low engine speed, no improvement in BSFC is noticed when w/o emulsions are used as fuel. Engine test results show that adding 15 and 30 percent water to diesel fuel increases the BSFC by an average of 2.12 and 3.83 percent respectively at 1000 RPM and 88°F ambient temperature. A maximum increase of 4.35 percent is obtained when 30 percent w/o emulsion is used. (see Table II and Figure 11).
3. Heating the intake air reduces the volumetric efficiency. (see Figures 12 and 13).
4. Heating the intake air increases the BSFC at high engine loads and may improve the BSFC at low engine loads. (see figures 14 - 21).
5. The ignition delay period increases with the increase of the water content of the emulsion. (see Figure 22)
6. Heating the intake air reduces the ignition delay period when neat and emulsionfied fuels are used. (see Figures 23, 27).

7. The test results obtained using JP4 as baseline fuel followed the same trend as that obtained when diesel fuel #2 was used as baseline fuel. However at high water content in the emulsion (45%) problems of starting and severe knock were noticed during testing. (see Figures 28, 34).
8. Preliminary tests on the preheating of the emulsionfied fuel show that at high temperatures water separation and emulsion instabilities occur. Thus, while preheating neat fuels at high temperatures improve the combustion characteristics of the engine, the heating of emulsionfied fuels is not beneficial.
9. While increasing the water content in the emulsion reduces the opacity of the exhaust gases. Increasing the intake air temperature increases the opacity of the exhaust gases. (see Figures 35, 36)
10. While increasing the water content in the emulsion reduces NO_x emissions of the engine, increasing the intake air temperature increases NO_x emissions. (see Figures 37-38)
11. While increasing the water content in the emulsion increases unburned Hc and Co emissions of the engine, increasing the intake temperature reduces UHC and Co emissions at low loads. (See Figures 39-44)

Recommendations

1. Basic experimental studies on the cooperation and combustion of w/o emulsion sprays both in bombs and engines should be conducted to determine the role played by the microexplosion phenomenon in improving the combustion characteristics of diesel engines with emphasis on the study of the most effective parameters involved.
2. The effect of use of emulsionfied fuels in turbocharged or supercharged diesel engines should be studied. Turbocharged engines can use high intake air temperatures thus reducing the ignition delay without scarificing the volumetric efficiency of the engine.
3. The effect of use of emulsionfied fuel in adiabatic diesel engines should be studied. It is anticipated that better combustion characteristics (short ignition relay), partial cooling of the engine (reduced thermal stresses), and better soot and NO_x emissions may result from this study.
4. Research work to develop w/o emulsions that can stay stable for longer periods of time is needed for future use of the emulsions as fuel in diesel engines.

REFERENCES

1. Valdmamis, E. and Wulfhorst, B., "The Effect of Emulsified Fuels and Water Introduction on Diesel Combustion," SAE paper no. 700736, 1970.
2. Storment, J. O., Coon, C. W., "Single-Cylinder Diesel Engine Tests with Unstabilized Water-In-Fuel Emulsions," Department of Engine and Vehicle Research Southwest Research Institute, San Antonio, Texas, 1979.
3. Cook, D. H., and Law, C. K., "A Preliminary Study on the Utilization of Water-In-Oil Emulsions in Diesel Engines," Combustion Science and Technology, 18, 217-221, 1978.
4. Crookes, R. J., Nazha, M.A.A., Janoter, M.S., Story, T., "Investigation into the Combustion of Water/Diesel Fuel Emulsions" SAE paper #80094, 1980.
5. Ivanov, V. M. and Nefedov, P.I., "Experimental Investigation of the Combustion Process of Natural and Emulsified Liquid Fuels," NASA Ttranslations #258, 1965.
6. Dryer, F. L., "Water Addition to Practical Combustion Systems Concepts and Applications," Paper presented at the Sixteenth Symposium (International) on Combustion, (279-295), 1976.
7. Murayama, T., Tsukahara, M., Morishima, Y., Miyamoto, N., "Experimental Reduction of NO_x, Smoke and BSFC in a Diesel Engine Using Uniquely Produced Water (0-80%) to Fuel Emulsion," SAE paper #780224, 1978.
8. Lawson A., and Last, A. J., "Modified Fuels for Diesel Engines by Application of Unstabilized Emulsions," SAE paper #790825, 1979.
9. Greeves, G., Khan, I.M., and Onion, G., "Effects of Water Introduction on Diesel Engine Combustion and Emissions," Combustion and Flame, 321-336, 1978.
10. Weatherford, W. D., Fodor, G., Naegli, D.W., Owens, E.C. and Wright, B.R., "Army Fine Resistant Diesel Fuel," SAE paper #790926, 1979.
11. Holmer, E., Berg, P.S., Bertilsson, B. I., "The Utilization of Alternative Fuels in a Diesel Engine Using Different Methods," SAE paper #800544, 1980.

12. Khan, N. and Gallahali, S.R., "Performance and Emissions Characteristics of a Diesel Engine Burning Unstabilized Emulsions of Diesel Fuel with Water, Methanol and Ethanol," SAE paper #811210, 1981.
13. Henein, N.A., "Analysis of Pollutant Formation and Control and Fuel Economy in Diesel Engines", Prog. Energy Combustion Science Vol. 1, (165-207), Pergamon Press, Great Britain, 1976.
14. Henein, N.A. and Bolt, J.A., "Ignition Delay in Diesel Engines," SAE paper #670007, 1967.
15. Henein, N.A. and Bolt, J.A., "Correlation of Air Charge Temperature and Ignition Delay for Several Fuels in a Diesel Engine," SAE paper #690252, 1969.
16. Hiroyasu, H., "Ignition Delay of Fuel Sprays in a Constant Volume Bomb".
17. Galallos, A.E., "Some Effects of Air and Fuel Temperature on Spray Penetration and Dispersion," Tech. Notes, NACA, Washington, 333, 1930.
18. Gerrish, H. C. and Ayer, B.E., Influence of Oil Temperature on the Combustion in a Prechamber Compression Ignition Engine" Tech Notes, NACA, Washington, 565, 1936.
19. Temple-Pediani, R.W., "Effect of Preinjection Fuel Temperature upon Diesel Engine Ignition Delay and Soot Formation", Proc. Inst. Mech. Engrs, Vol. 186, 1973.
20. Hoppie, L.O., "The Influence of Initial Fuel Temperature on Ignition Delay," SAE paper #820356, 1982.
21. Scharnweber, D. H. and Hoppie, L.O., "Hypergolic Combustion in an Internal Combustion Engines" SAE paper #850089, 1985.
22. Walsh, G. J. and Cheng, W. K., "Effects of Highly-Heated Fuel on Diesel Combustion," SAE paper #850088, 1985.

APPENDIX A

TABLE A-1

DIESEL ENGINE SPECIFICATIONS

Cylinder Bore	3.8125 inches
Stroke	3.750 inches
Displacement	42.810 cubic inches
Type of Cooling	Water Cooled
Combustion Chamber	Direct Injection
Piston Type	"Mexican Hat"
Number of Compression Rings	2
Number of Oil Control Rings	1
Compression Ratio	16.7:1
Lubricating Oil	Castrol 20W-50
IVO	18 Degrees BTDC
IVC	58 Degrees ABDC
EVO	124 Degrees ATDC
EVC	20 Degrees ATDC
Maximum Lift for Both Valves	0.228 inches

The intake valve is equipped with a 60 degree shroud to enhance the swirl component of the intake air.

FUEL INJECTION SPECIFICATIONS

Fuel Injection Pump	Bosch APE1B
Fuel Injection Timing	0-40 Degrees BTDC, Manual
Fuel Injector Nozzle	Sims NL141

APPENDIX A CONTINUED

Number of Nozzle Holes	4
Nozzle Hole Diameter	0.27 mm
Injector Crack Pressure	2600 Psi

APPENDIX B

TABLE B-1

ENGINE INPUT PARAMETERS

<u>Parameter</u>	<u>Range</u>	<u>Precision</u> (+ or -)	<u>Instrumentation</u>
Fuel Flow	1-1000 gr	0.01 gr	Fisher/Ainsworth LC-1000
Air Flow	0-200 CFM	0.5 CFM	Meriam LFE
Speed	0-7000 RPM	2.0 RPM	Magnetic Pickup
Fuel Injection Timing	0-50 BTDC	0.5 CA	Manual
Inlet Coolant Temperature	70-200 F	1.0 F	Thermo Electronic
Load	0-100 LBS	0.1 LB	BLH Load Cell
Atmospheric Pressure	20-32" Hg	0.01" Hg	Fisher Scientific Barometer
Intake Air Temp.	60-450 F	1.0 F	Omega Temp. Controller
Air Humidity	10-90 %	1.0 %	Wet And Dry Bulb Thermometer

APPENDIX C

TABLE C-1

ENGINE OUTPUT PARAMETERS

<u>Parameter</u>	<u>Range</u>	<u>Precision</u> (+ or -)	<u>Instrumentation</u>
Smoke Opacity	0-100 %	1.0 %	Smoke Opacity Monitor
Exhaust Temp.	32-1400 F	1.0 F	Omega Model 660
Outlet Coolant Temperature	70-200 F	1.0 F	Thermo Electronic
Oil Gallery Temperature	70-400 F	1.0 F	Thermo Electronic
Fuel Injection Pressure	0-200 Bar	5.59 Pc/bar	Kistler (603b)
Cylinder Press.	0-250 Bar	14.0 Pc/bar	Kistler (6121)
Oil Press.	0-100 Psi	0.5 Psi	Press. Gauge
Needle Lift	0-1.0 mm	8.0 v/mm	Bently-Nevada (Probe Type 190, Proximiter Model 3000)

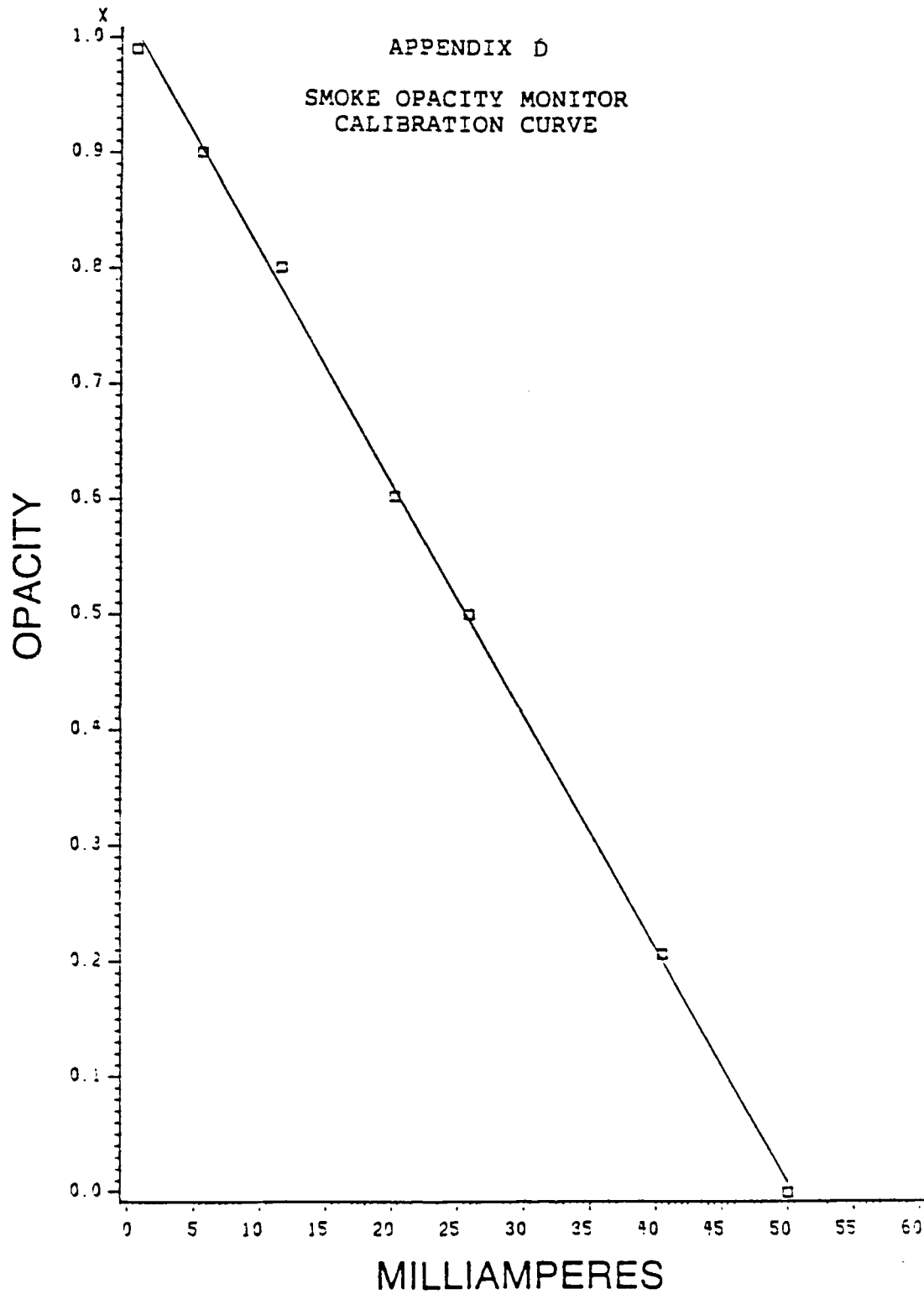

SMOKE OPACITY MONITOR CALIBRATION CURVE

APPENDIX E

TABLE E-1

PROPERTIES OF DIESEL FUEL #2

Gravity, API	34.6
Specific Gravity, g/ml	0.8519
Distillation, C	
IBP	199
10% Recovered	238
50% Recovered	272
90% Recovered	322
EP	355
Residue, Vol%	2.0
Loss, Vol%	0.0
Viscosity, cST at -20 Degrees C	Froze
Aromatics, FIA, Vol%	3.20
Olefins, FIA, Vol%	30.6
Mono-Aromatics, UV, wt%	6.85
Di-Aromatics, UV, wt%	7.82
Tri-Aromatics, UV, wt%	0.29
Hydrogen, wt%	12.95
Carbon, wt%	86.23
Nitrogen, wt%	0.01
Sulfur, wt%	0.380
Refractive Index at 20 Degrees C	1.4751
Carbon Residue, 10% Btms, wt%	0.15
Aniline Point, Degrees C (F)	74 (165)

APPENDIX E CONTINUED

Flash Point, Degrees C	74
Net Heat of Combustion Btu/lb	18,342
Calculated Net Heat of Combustion	18,543
Cetane Number	50.1
Cetane Index (D 976-80)	47.7

The following heats of combustion are determined in the lab using a Parr Oxygen Bomb Calorimeter. These two values are used in the data reduction program.

Heat of Combustion for #2 diesel Fuel (Btu/lb)	18,449.14
Heat of Combustion for the Surfactant (Btu/lb)	14,123.96

PROPERTIES OF
JP-4 FUEL

TABLE F-1

	<u>AL-10583-T</u> <u>JP-4</u>
Gravity, °API	54.0
Specific Gravity, g/mL	0.7628
Distillation, C	
IBP	58
10% Recovered	91
50% Recovered	149
90% Recovered	229
EP	255
Residue, vol%	1.5
Loss, vol%	0
Viscosity, cSt at -20°C	1.98
Viscosity, cSt at 40°C	0.78
Aromatics, FIA, vol%	14.8
Olefins, FIA, vol%	1.0
Mono-Aromatics, UV, wt%	10.60
Di-Aromatics, UV, wt%	1.19
Tri-Aromatics, UV, wt%	0.01
Hydrogen, wt%	14.34
Carbon, wt%	85.65
Nitrogen, wt%	< 0.01
Sulfur, wt%	0.018
Refractive Index at 20°C	1.4336
Carbon Residue, 10% Btms, wt%	0.07
Aniline Point, °C(°F)	57(135)
Flash Point, °C	-22
Net Heat of Combustion,	
MJ/kg	43.303
Btu/lb	18617
Calculated Net Heat of Combustion,	
MJ/kg	43.606
Btu/lb	18747
Cetane Number	34.5
Cetane Index (D 976-80)	34.7

APPENDIX G

DATA REDUCTION PROGRAM

```

10 FOR K=1 TO 30
20 IF K=1 THEN 30 ELSE 170
30 LPRINT "UNITS ARE : "
40 LPRINT
50 LPRINT "LOAD (LD): LBF"
60 LPRINT "AIR FLOW RATE (AIR): LBM / MIN"
70 LPRINT "FUEL FLOW RATE (FUEL): LBM / MIN"
80 LPRINT "AIR FUEL RATIO (A/F): NONE"
90 LPRINT "CORRECTED BRAKE HORSEPOWER (C.BHP): HP"
100 LPRINT "BRAKE MEAN EFFECTIVE PRESSURE (BMEP): PSI"
110 LPRINT "INJECTION TIMING (INJ): DEG. CA BTDC"
120 LPRINT "IGNITION DELAY PERIOD (ID): MILLISECONDS"
130 LPRINT "VOLUMETRIC EFFICIENCY (V.EFF): %"
140 LPRINT "EXHAUST GAS TEMPERATURE (E.TEMP): DEG. FARENHEIGHT"
150 LPRINT "EXHAUST SMOKE OPACITY (OP): %"
160 LPRINT
170 READ NUM,I,M,D,YE,EM,TEMPI,N,AMBT
180 FOR J=1 TO I
190 READ F,PD,FC,T,BP,CFT,SMNO,E.TEMP,INJ,ID
200 IF J>1 THEN 300 ELSE 210
210 LPRINT
220 LPRINT "-----",I"-----"
230 LPRINT "ENGINE SPEED = "N "RPM" PERCENT WATER = "EM;
240 LPRINT " INTAKE AIR TEMP. = "TEMPI "F"
250 LPRINT
260 LPRINT "LD";TAB(6)"AIR";TAB(12)"FUEL";TAB(20)"A/F";TAB(27)"C.BHP";
270 LPRINT TAB(34)"BMEP";TAB(42)"BSFC";TAB(49)"INJ";TAB(56)"ID";TAB(61)"V.EFF";
280 LPRINT TAB(68)"E.TEMP";TAB(76)"% OP"
290 LPRINT
300 DENDF = .9519
310 DENSUR = .9996
320 DENW = 1!
330 HVSUR = 14123.9638#
340 HVDF = 18449.145#
350 RAIR = 53.331
360 CYLVOL = 42.809
370 LEVER = .75
380 IF EM=0! THEN 470 ELSE 390
390 Z = (EM-DENW-(100!-(EM-2!)))*DENDF-1!-DENSUR)/100!
400 Y = FC/(Z*T)
410 X = Y*(100!-(EM-2!))/100!
420 XS = Y*2!/100!
430 MDF = X*DENDF*2.205/1000!
440 MSUR = XS*DENSUR*2.205/1000!
450 EQMF = MDF*1!-MSUR*HVSUR/HVDF
460 MF = EQMF
470 CFM = PD*100!/8!
480 DENAIR = BP*14.696*144/(RAIR*29.92*(AMBT+460))
490 MA = CFM*BP*CFT*DENAIR/(29.92)
500 IF EM=0! THEN 510 ELSE 530
510 MDF = FC/(453.597*T)
520 MF = MDF
530 AF = MA/MF
540 MTH = DENAIR*CYLVOL*N/(2*12*3!)
550 V.EFF = MA*100!/MTH
560 BHP = F*LEVER*2!*3.14159*N/33000!
570 PCF = (29.3139/BP)*1.1
580 TCF = ((AMBT+460!)/537!)*1.2
590 C.BHP = BHP*(PCF*TCF)*.3
600 IF EM=0! THEN 610 ELSE 640
610 BSFC = MDF*60!/C.BHP
620 GOTO 640
630 BSFC = EQMF*60!/C.BHP

```

APPENDIX G CONTINUED

31

```
640 BMEP = BHPC*33000!*2!*12!/(CYLVOL*N)
650 IF SMNO<=1! THEN 660 ELSE 660
660 OP = 0!
670 GOTO 690
680 OP = 101.39-1.99*SMNO
690 LPRINT USING "##.";F;
700 LPRINT USING "###.###";MA,MF;
710 LPRINT USING "###.###";AF;
720 LPRINT USING "###.###";C.BHP;
730 LPRINT USING "###.###";BMEP;
740 LPRINT USING "###.###";BSFC;
750 LPRINT USING "###.###";INJ;
760 LPRINT USING "###.###";ID;
770 LPRINT USING "###.###";V.EFF;
780 LPRINT USING "###.###";E.TEMP;
790 LPRINT USING "###.###";OP
800 NEXT J
810 NEXT K
```

APPENDIX H
DETAILS OF CALCULATIONS

Brake Horsepower

The brake horsepower is determined from a product of the dynamometer lever arm length, the load placed on the arm, and the engine speed.

$$\text{BHP} = L \times F \times N \times C \quad (1)$$

Corrected Brake Horsepower

The corrected brake horsepower is determined using the following pressure and temperature correction factors:

$$\text{PCF} = \frac{29.3139}{\text{BP}}^{1.1} \quad (2)$$

$$\text{TCF} = \frac{\text{AMBT} + 460}{537}^{1.2} \quad (3)$$

The corrected brake horsepower is then calculated using the equation:

$$\text{C.BHP} = \text{BHP} (\text{PCF} \times \text{TCF})^{0.3} \quad (4)$$

Brake Mean Effective Pressure

The brake mean effective pressure is calculated by dividing the corrected brake horsepower by the engine displacement.

$$\text{BMEP} = \frac{\text{BHPC}}{\text{CYLVOL}} \quad (5)$$

Fuel Flow Rate

The fuel flow rate is determined by measuring the amount of time required for the engine to consume a specified mass of fuel. This flow rate is calculated by dividing the mass of fuel consumed by the time to consume it.

Mass Flow Rate of Neat Fuel

The mass flow rate of neat fuel is calculated using the equation:

$$MDF = \frac{FC}{T} \quad (6)$$

Mass Flow Rate of Emulsified Fuel

When emulsified fuels are used corrections for the change in fuel composition have to be made since the fuel contains diesel fuel, surfactant, and various percentages of water.

The densities of diesel fuel #2, water, and surfactant are multiplied by their volume percentages in the fuel and added together to determine a composite fuel density.

$$Z = [EM \times DENW + (100 - (EM + 2)) \times DENDF + 2 \times DENSUR] / 100 \quad (7)$$

The volume fuel flow rate is then found by dividing the mass of fuel consumed by the composite fuel density and the time required to consume the fuel.

$$Y = \frac{FC}{Z \times T} \quad (8)$$

Separate volume flow rates of diesel fuel and surfactant are determined by multiplying the total fuel flow rate by the volume percentages of the diesel fuel and surfactant respectively.

$$X = \frac{Y \times (100 - (EM + 2))}{100} \quad (9)$$

$$XS = \frac{Y \times 2}{100} \quad (10)$$

The mass flow rates of diesel fuel and surfactant are calculated by multiplying the volume flow rate of each component by their respective densities.

$$MDF = X \times DENDF \quad (11)$$

$$MSUR = XS \times DENSUR \quad (12)$$

An equivalent fuel mass flow rate is then determined because the heating value of the surfactant is 23.44 percent lower than the heating value of pure diesel fuel #2. This calculation is necessary so comparisons in fuel consumption can be made between engine tests using neat and emulsified fuels. The equivalent fuel mass flow rate is found by correcting the surfactant flow rate. The surfactant flow rate is multiplied by the ratio of the heating value of surfactant to the heating value of diesel fuel. Thus the equivalent mass flow rate of fuel when using emulsions is based on the heating value of pure diesel fuel and found by adding the corrected flow rate of surfactant to the flow rate of pure diesel fuel.

$$EQMF = MDF \times 1 + MSUR \frac{HVSUR}{HVDF} \quad (13)$$

Mass Air Flow Rate

The air flow rate is calculated by including the calibration curve for the Meriam laminar flow element in the data reduction program. The pressure drop across the element is read into the program and the calibration curve is used to determine the air flow rate in cubic feet per minute.

$$CFM = \frac{PD \times 100}{8} \quad (14)$$

The air density is then calculated using the ideal gas law.

$$DENAIR = \frac{BP}{RAIR \times AMBT} \quad (15)$$

The air flow is corrected for temperature and pressure variations using the correction factors supplied by the manufacturer of the Meriam laminar flow element.

$$MA = \frac{CFM \times BP \times CFT \times DENAIR}{29.92} \quad (16)$$

Air Fuel Ratio

The air fuel ratio is calculated by dividing the air flow rate by the fuel flow rate.

Air Fuel Ratio Using Neat Fuel

The air fuel ratio is calculated for neat fuel using the equation:

$$AF = \frac{MA}{MDF} \quad (17)$$

Air Fuel Ratio Using Emulsified Fuels

The air fuel ratio is calculate for emulsified fuels using the equation:

$$AF = \frac{MA}{EQMF} \quad (18)$$

Brake Specific Fuel Consumption

The brake specific fuel consumption is calculated by dividing the mass flow rate of fuel by the corrected brake horsepower.

BSFC Using Neat Fuel

The brake specific fuel consumption is calculated for neat fuel using the equation:

$$BSFC = \frac{MDF}{C.BHP} \quad (19)$$

BSFC Using Emulsified Fuel

The brake specific fuel consumption is calculated for water/oil emulsions using the equation:

$$BSFC = \frac{EQMF}{C.BHP} \quad (20)$$

Volumetric Efficiency

The volumetric efficiency is calculated by dividing the air flow rate per cycle by the theoretical mass of air that would fill the engine displacement at ambient temperature and pressure. The theoretical mass

of air is given by:

$$MTH = \frac{DENAIR \times CYLVOL \times N}{2} \quad (21)$$

The volumetric efficiency is then calculated using the equation:

$$VEFF = \frac{MA}{MTH} \quad (22)$$

The Exhaust Smoke Opacity

The exhaust smoke opacity is determined using the equation for the smoke opacity monitor calibration curve found in Appendix I.

$$OP = 101.39 - 1.99 \times SMNO \quad (23)$$

Ignition Delay Period

The ignition delay period is determined using two methods. The first method is to analyze a photograph of the cylinder pressure, fuel injector needle lift, and degrees crank angle signals taken from the oscilloscope. The points where the fuel injector opens and the pressure rises due to combustion are compared against the crank angle degrees markers to determine the ignition delay period with units of degrees crank angle. This method however, is not very accurate since the crank angle markers can only be resolved to plus or minus 5.0 degrees CA.

The second method employs a Labmaster analog to digital converter and an IBM personal computer to digitize and store the needle lift and cylinder pressure analog signals. The sampling frequency using two channels is 12.5 KHz. Five hundred data points for each channel are stored per sample yielding a resolution of 0.08 milliseconds per data point. Initially a program was written to calculate the ignition delay period by mathematically analyzing the two digitized curves. The program determined the beginning of the ignition delay period by noting when the injector needle moved a certain distance (displayed as a voltage amplitude) from its equilibrium closed position. The end of the ignition delay period was determined by differentiating the

cylinder pressure curve assuming that the pressure rise due to combustion coincided with the maximum pressure gradient. This program however, proved to be inaccurate and inconsistent since the maximum pressure gradient in the cylinder did not always coincide with the beginning of combustion.

The ignition delay period is finally determined by printing out the digitized data points (voltage values) of the needle lift and cylinder pressure signals. See Table IV. These points are inspected visually to determine where the fuel injector opens and the cylinder pressure increases due to combustion. The number of data points between the opening of the fuel injector and the beginning of combustion are counted. A value for the pressure rise ignition delay period is then determined by multiplying this number of data points by the time (0.08 milliseconds) between the digitized voltage values.

$$ID = \# \text{ of Data Points} \times 0.08 \text{ Milliseconds} \quad (24)$$

This method is labor intensive, but proves to be the most accurate. The ignition delay period can be determined to within plus or minus 0.08 milliseconds. The computer is used to store two sets of ignition delay data for each engine test condition. These two ignition delay period values are later averaged and recorded. The two methods of determining the ignition delay period as described above are compared and found to agree with each other. The second method however, is able to achieve higher resolution since 0.08 milliseconds (the time interval between the digitized data points when using a sampling frequency of 12.5 KHz) corresponds to .48 and .96 degrees crank angle at engine speeds of 1000 and 2000 RPM respectively.

Sample Calculations

The following calculations are performed for data sets 13 and 16 which correspond to engine tests using neat and emulsified fuels respectively. Calculations are performed for the 24 lb load in each case. The corresponding output of the data reduction program is given in Table III.

Input Parameters for Data Set 13

Percent Water in the Fuel (EM)	= 0.0 %
Intake Air Temperature (TEMPI)	= 79.0 F
Engine Speed (N)	= 2000 RPM
Ambient Air Temperature (AMBT)	= 79.0 F
Load on Dynamometer Arm (F)	= 24 LB
Pressure Drop Across the Air Flow Meter (PD)	= 1.595 " H ₂ O
Mass of Fuel Consumed (FC)	= 100.00 GM
Time to Consume the Fuel (T)	= 3.592 MIN
Barometric Pressure (BP)	= 29.810 " HG
Temperature Correction Factor for the Air Flow Meter (CFT)	= 0.9674
Smoke Number (SMNO)	= 37.50 mA

Calculation of Performance Parameters for Data Set Number 13 (Neat Fuel)

From Equation (1):

$$\begin{aligned} \text{Brake Horsepower} &= \frac{0.75 \times 24.0 \times 2 \times 3.14159 \times 2000}{33000} \\ &= 6.854 \text{ HP} \end{aligned}$$

From Equations (2) and (3):

$$\begin{aligned} \text{Pressure Correction Factor} &= \frac{29.3139^{1.1}}{29.810} \\ &= 0.9817 \end{aligned}$$

Temperature Correction Factor

$$\begin{aligned} &= \frac{79.0 + 460^{1.2}}{537} \\ &= 1.0045 \end{aligned}$$

From Equation (4):

$$\begin{aligned} \text{Corrected Brake Horsepower} &= 6.854 (0.9817 \times 1.0045)^{0.3} \\ &= 6.826 \text{ HP} \end{aligned}$$

From Equation (5):

$$\begin{aligned} \text{Brake Mean Effective Pressure} &= \frac{6.826 \times 33000 \times 2 \times 12}{42.809 \times 2000} \\ &= 63.140 \text{ PSI} \end{aligned}$$

From Equation (6):

$$\begin{aligned} \text{Mass Flow Rate of Diesel Fuel} & \\ &= \frac{100.00}{3.592 \times 453.597} \\ &= 0.0614 \text{ LBM} \end{aligned}$$

From Equation (14):

$$\begin{aligned} \text{Air Density} &= \frac{29.810 \times 14.696 \times 144}{(53.331 \times 29.92 (79.0 + 460))} \\ &= 0.0733 \text{ LBM / CC} \end{aligned}$$

Combining Equations (15) and (16):

$$\begin{aligned} \text{Air Mass Flow Rate} & \\ &= 1.595 \times 100 \times 29.810 \times 0.9674 \\ &\quad \times 0.0733 / (29.92 \times 8) \\ &= 1.4086 \text{ LBM / MIN} \end{aligned}$$

From Equation (17):

$$\begin{aligned} \text{Air Fuel Ratio} &= \frac{1.4086}{0.0614} \\ &= 22.9414 \end{aligned}$$

From Equation (19):

$$\begin{aligned} \text{Brake Specific Fuel Consumption} & \\ &= \frac{0.0614 \times 60}{6.826} \\ &= 0.5395 \text{ LBM FUEL / HP HR} \end{aligned}$$

From Equation (21):

$$\begin{aligned} \text{Theoretical Mass of Air} & \\ &= \frac{0.0733 \times 42.809 \times 2000}{2 \times 12 \times 12 \times 12} \\ &= 1.8159 \text{ LBM} \end{aligned}$$

From Equation (22):

$$\begin{aligned} \text{Volumetric Efficiency} & \\ &= \frac{1.4086 \times 100}{1.8159} \\ &= 77.57 \% \end{aligned}$$

From Equation (23):

$$\begin{aligned} \text{Exhaust Smoke Opacity} & \\ &= 101.39 - 1.99 \times 37.50 \\ &= 26.77 \% \end{aligned}$$

Input Parameters for Data Set 16

Percent Water in the Fuel (EM)	= 15.0 %
Intake Air Temperature (TEMPI)	= 81.0 F
Engine Speed (N)	= 2000 RPM
Ambient Air Temperature (AMBT)	= 81.0 F
Load on Dynamometer Arm (F)	= 24.0 LB
Pressure Drop Across the Air Flow Meter (PD)	= 1.655 " H ₂ O
Mass of Fuel Consumed (FC)	= 100.00 GM
Time to Consume the Fuel (T)	= 2.998 MIN
Barometric Pressure (BP)	= 29.60 " HG
Temperature Correction Factor for the Air Flow Meter (CFT)	= 0.9611
Smoke Number (SMNO)	= 45.0 mA

Calculation of Performance Parameters for Data Set Number 16 (Emulsified Fuel)

The equations used to calculate the performance parameters when using emulsified fuels are the same as the neat fuel equations except that the flow rate of diesel fuel is replaced with the flow rate of emulsified fuel. The calculations of the corrected brake horsepower, brake mean effective pressure, air flow rate, volumetric efficiency, and smoke opacity are identical to the calculations performed in section 4.2.2. Only the results needed for further calculations are shown here.

$$\begin{aligned} \text{C.BHP} &= 6.851 \text{ HP} \\ \text{BMEP} &= 63.37 \text{ PSI} \\ \text{MA} &= 1.427 \text{ LBM / MIN} \end{aligned}$$

The mass flow rate of emulsified fuel (EQMF) is found using equations (7) through (13).

From Equation (7):

$$\begin{aligned} \text{Composite Fuel Density} &= [15 \times 1.0 + (100 - (15 + 2)) \\ &\quad \times 0.8519 + 2 \times 0.9996] / 100 \\ &= 0.8771 \text{ GM / CC} \end{aligned}$$

From Equation (8):

$$\begin{aligned} \text{Total Volume Fuel Flow Rate} &= \frac{100}{0.8771 \times 2.998} \\ &= 38.0307 \text{ CC / MIN} \end{aligned}$$

From Equation (9):

$$\begin{aligned} & \text{Volume Flow Rate of Diesel Fuel} \\ & = \frac{38.0307 \times (100 - (15 + 2))}{100} \\ & = 31.5655 \text{ CC / MIN} \end{aligned}$$

From Equation (10):

$$\begin{aligned} & \text{Volume Rate of Surfactant} \\ & = \frac{38.0307 \times 2}{100} \\ & = 0.7606 \text{ CC / MIN.} \end{aligned}$$

From Equation (11):

$$\begin{aligned} & \text{Mass Flow Rate of Diesel Fuel} \\ & = \frac{31.5655 \times 0.8519 \times 2.205}{1000} \\ & = .05929 \text{ LBM / MIN} \end{aligned}$$

From Equation (12):

$$\begin{aligned} & \text{Mass Flow Rate of Surfactant} \\ & = \frac{0.7606 \times 0.9996 \times 2.205}{1000} \\ & = 0.00676 \text{ LBM / MIN} \end{aligned}$$

From Equation (13):

$$\begin{aligned} & \text{Equivalent Mass Flow Rate of Fuel} \\ & = \frac{0.0529 \times 1 + 0.00676 \times 14123.9658}{18449.145} \\ & = 0.060577 \text{ LBM / MIN} \end{aligned}$$

From Equation (18):

$$\begin{aligned} \text{Air Fuel Ratio} & = \frac{1.427}{0.060557} \\ & = 23.557 \end{aligned}$$

From Equation (20):

$$\begin{aligned} & \text{Brake Specific Fuel Consumption} \\ & = \frac{6.0577 \times 10 \times 60}{6.851} \\ & = 0.5305 \text{ LBM FUEL / HP HR} \end{aligned}$$

Ignition Delay Period Calculation

Table IV is the output of the computer program which prints out the digitized voltage values for the cylinder pressure and needle lift signals. Figure is the plot of they cylinder pressure and needle lift signals corresponding to Table IV. The data acquisition software is written such taht a 10 volt input to the A/D converter corresponds to an amplitude of 2047. The first column contains the data point number from 1 to 500 since 500 data points are collected per channel. Columns 2 - 4 contain the needle lift amplitude, slop of the needle lift curve, cylinder pressure amplitude, and slope of the cylinder pressure curve respectively. By inspecting the needle lift and cylinder pressure slopes it is evident that the fuel injector needle begins to open at data point 226 and the cylinder pressure increases due to combustion at data point 240. The ignition delay period is then calculated using equation 24.

From Equation (24):

$$\begin{aligned}\text{Ignition Delay Period} &= 14 \times .08 \text{ MILLISECONDS} \\ &= 1.12 \text{ MILLISECONDS}\end{aligned}$$

TABLE II
 STATISTICALLY ESTABLISHED BSFC RESULTS

Engine <u>RPM</u>	BMEP <u>Psi</u>	H ₂ O In Fuel <u>Vol. %</u>	Ave BSFC <u>Lbm/Bhp Hr</u>	Percent <u>Change</u>
1000	41.9	0.0	0.5864	
"	"	15.0	0.5960	+1.64
"	"	30.0	0.6108	+4.16
"	52.4	0.0	0.5516	
"	"	15.0	0.5673	+2.85
"	"	30.0	0.5756	+4.35
"	62.9	0.0	0.5420	
"	"	15.0	0.5520	+1.88
"	"	30.0	0.5581	+2.97
2000	42.1	0.0	0.6124	
"	"	15.0	0.6014	-1.80
"	"	30.0	0.6024	-1.34
"	52.6	0.0	0.5709	
"	"	15.0	0.5580	-2.26
"	"	30.0	0.5586	-2.15
"	63.1	0.0	0.5458	
"	"	15.0	0.5263	-3.57
"	"	30.0	0.5334	-2.27

TABLE III
SAMPLE OF COMPUTED RESULTS

UNITS ARE :

LOAD (LD): LBF
AIR FLOW RATE (AIR): LBM / MIN
FUEL FLOW RATE (FUEL): LBM / MIN
AIR FUEL RATIO (A/F): NONE
CORRECTED BRAKE HORSEPOWER (C.BHP): HP
BRAKE MEAN EFFECTIVE PRESSURE (BMEP): PSI
BRAKE SPECIFIC FUEL CONSUMPTION (BSFC): LBM FUEL / HP HR
INJECTION TIMING (INJ): DEG. CA BTDC
IGNITION DELAY PERIOD (ID): MILLISECONDS
VOLUMETRIC EFFICIENCY (V.EFF): %
EXHAUST GAS TEMPERATURE (E.TEMP): DEG. FARENHEIGHT
EXHAUST SMOKE OPACITY (OP): %

===== 1 =====												
ENGINE SPEED = 1000 RPM				PERCENT WATER = 0				INTAKE AIR TEMP. = 81.5 F				
LD	AIR	FUEL	A/F	C.BHP	BMEP	BSFC	INJ	ID	V.EFF	E.TEMP	% OP	
8	0.652	0.015	44.112	1.142	21.13	0.7759	23.0	1.44	72.56	431.6	1.89	
12	0.647	0.018	35.955	1.713	31.70	0.6304	22.5	1.36	72.08	537.8	1.89	
16	0.646	0.022	29.620	2.284	42.26	0.5730	21.0	1.28	71.96	633.2	1.89	
20	0.642	0.026	24.988	2.855	52.83	0.5398	22.0	1.20	71.48	725.0	8.26	
24	0.641	0.030	21.457	3.427	63.39	0.5231	22.0	1.28	71.36	815.0	17.81	
===== 2 =====												
ENGINE SPEED = 1000 RPM				PERCENT WATER = 0				INTAKE AIR TEMP. = 167 F				
LD	AIR	FUEL	A/F	C.BHP	BMEP	BSFC	INJ	ID	V.EFF	E.TEMP	% OP	
8	0.619	0.015	40.862	1.143	21.14	0.7956	23.0	1.20	69.03	539.6	1.89	
12	0.607	0.019	31.862	1.714	31.71	0.6671	24.0	1.20	67.70	618.8	4.28	
16	0.606	0.023	26.469	2.285	42.27	0.6010	23.0	1.12	67.49	708.8	6.86	
20	0.596	0.027	22.202	2.856	52.83	0.5640	24.0	1.12	66.41	797.0	11.84	
24	0.587	0.031	18.672	3.427	63.40	0.5508	25.0	1.12	65.45	888.8	28.16	
===== 3 =====												
ENGINE SPEED = 1000 RPM				PERCENT WATER = 0				INTAKE AIR TEMP. = 302 F				
LD	AIR	FUEL	A/F	C.BHP	BMEP	BSFC	INJ	ID	V.EFF	E.TEMP	% OP	
8	0.571	0.016	35.109	1.138	21.06	0.8571	22.0	0.96	63.00	638.6	7.26	
12	0.561	0.020	28.126	1.708	31.59	0.7011	22.0	1.04	61.92	730.4	10.65	
16	0.551	0.024	22.630	2.277	42.12	0.6417	21.0	0.92	60.77	851.0	14.23	
20	0.546	0.029	18.881	2.846	52.65	0.6159	26.0	1.00	60.18	923.0	26.17	
24	0.540	0.037	14.672	3.415	63.18	0.6460	28.5	0.96	59.50	1041.8	45.47	
===== 4 =====												
ENGINE SPEED = 1000 RPM				PERCENT WATER = 15				INTAKE AIR TEMP. = 77.5 F				
LD	AIR	FUEL	A/F	C.BHP	BMEP	BSFC	INJ	ID	V.EFF	E.TEMP	% OP	
8	0.665	0.016	41.771	1.138	21.05	0.8399	22.0	1.48	73.30	456.8	1.89	
12	0.643	0.019	33.819	1.707	31.58	0.6846	21.0	1.44	70.84	537.8	1.89	
16	0.638	0.023	27.385	2.276	42.10	0.6144	21.0	1.48	70.28	638.6	1.89	
20	0.644	0.027	23.678	2.844	52.62	0.5740	23.0	1.44	70.93	725.0	3.08	
24	0.640	0.031	20.577	3.413	63.15	0.5467	24.0	1.44	70.45	824.0	8.85	

TABLE III Continued

===== 5 =====											
ENGINE SPEED = 1000 RPM				PERCENT WATER = 15				INTAKE AIR TEMP. = 167 F			
LD	AIR	FUEL	A/F	C.BHP	BMEP	BSFC	INJ	ID	V.EFF	E. TEMP	% OP
8	0.622	0.016	39.015	1.141	21.10	0.8385	19.0	1.44	68.93	527.0	1.89
12	0.612	0.019	31.589	1.711	31.65	0.6790	20.5	1.36	67.83	613.4	1.89
16	0.611	0.023	26.281	2.281	42.21	0.6111	21.0	1.36	67.72	705.2	10.85
20	0.604	0.027	22.741	2.852	52.76	0.5587	21.0	1.28	66.99	807.8	14.43
24	0.603	0.031	19.421	3.423	63.32	0.5439	23.0	1.28	66.87	892.4	19.80
===== 6 =====											
ENGINE SPEED = 1000 RPM				PERCENT WATER = 15				INTAKE AIR TEMP. = 302 F			
LD	AIR	FUEL	A/F	C.BHP	BMEP	BSFC	INJ	ID	V.EFF	E. TEMP	% OP
8	0.565	0.014	39.249	1.141	21.10	0.7575	21.0	1.24	62.68	584.6	1.89
12	0.561	0.019	28.981	1.711	31.65	0.6787	21.0	1.24	62.20	692.6	4.68
16	0.557	0.024	23.284	2.281	42.21	0.6287	22.0	1.12	61.72	802.4	10.85
20	0.551	0.029	19.193	2.852	52.76	0.6043	22.5	1.12	61.14	915.8	12.83
24	0.541	0.034	15.920	3.422	63.32	0.5961	24.0	1.04	60.05	1011.2	26.17
===== 7 =====											
ENGINE SPEED = 1000 RPM				PERCENT WATER = 30				INTAKE AIR TEMP. = 82 F			
LD	AIR	FUEL	A/F	C.BHP	BMEP	BSFC	INJ	ID	V.EFF	E. TEMP	% OP
8	0.658	0.016	40.924	1.140	21.08	0.8463	25.0	1.96	72.76	420.8	1.89
12	0.657	0.019	33.743	1.709	31.63	0.6831	23.0	2.00	72.64	501.8	1.89
16	0.651	0.023	28.829	2.279	42.17	0.5947	23.0	1.84	72.04	595.4	1.89
20	0.646	0.027	24.268	2.849	52.71	0.5605	23.0	1.84	71.44	692.6	5.47
24	0.636	0.030	21.056	3.419	63.25	0.5302	23.0	1.76	70.35	784.4	6.86
===== 8 =====											
ENGINE SPEED = 1000 RPM				PERCENT WATER = 30				INTAKE AIR TEMP. = 167 F			
LD	AIR	FUEL	A/F	C.BHP	BMEP	BSFC	INJ	ID	V.EFF	E. TEMP	% OP
8	0.618	0.016	39.252	1.140	21.09	0.8286	24.0	1.72	68.39	491.0	1.89
12	0.617	0.019	32.329	1.710	31.63	0.6696	22.0	1.60	68.28	577.4	4.28
16	0.611	0.024	25.831	2.280	42.18	0.6230	22.0	1.60	67.68	683.6	1.89
20	0.608	0.027	22.416	2.850	52.72	0.5715	22.0	1.56	67.35	780.8	1.89
24	0.596	0.031	19.159	3.419	63.26	0.5457	23.0	1.48	65.93	867.2	9.25
===== 9 =====											
ENGINE SPEED = 1000 RPM				PERCENT WATER = 30				INTAKE AIR TEMP. = 302 F			
LD	AIR	FUEL	A/F	C.BHP	BMEP	BSFC	INJ	ID	V.EFF	E. TEMP	% OP
8	0.554	0.016	35.676	1.144	21.16	0.8144	18.5	1.36	61.92	584.6	1.89
12	0.550	0.019	28.533	1.716	31.75	0.6745	18.5	1.28	61.54	698.0	2.69
16	0.544	0.023	23.175	2.288	42.33	0.6157	19.0	1.20	60.86	813.2	7.06
20	0.544	0.028	19.280	2.860	52.92	0.5916	21.0	1.24	60.83	914.0	11.24
24	0.534	0.034	15.585	3.433	63.50	0.5985	21.0	1.20	59.69	1014.8	14.03
===== 10 =====											
ENGINE SPEED = 1000 RPM				PERCENT WATER = 45				INTAKE AIR TEMP. = 86 F			
LD	AIR	FUEL	A/F	C.BHP	BMEP	BSFC	INJ	ID	V.EFF	E. TEMP	% OP
8	0.636	0.017	38.549	1.144	21.17	0.8655	29.0	2.96	71.24	415.4	1.89
12	0.631	0.020	32.295	1.717	31.77	0.6831	26.0	3.04	70.72	489.2	1.89
16	0.627	0.023	27.290	2.289	42.36	0.6022	24.0	2.96	70.35	579.2	1.89
20	0.619	0.026	23.410	2.862	52.94	0.5541	23.0	2.64	69.30	656.6	1.89
24	0.615	0.031	20.105	3.434	63.54	0.5343	22.0	2.52	68.91	750.2	1.89

TABLE III Continued

===== 11 =====											
ENGINE SPEED = 1000 RPM			PERCENT WATER = 45			INTAKE AIR TEMP. = 167 F					
LD	AIR	FUEL	A/F	C.BHP	BMEP	BSFC	INJ	ID	V.EFF	E.TEMP	% OP
8	0.611	0.017	36.433	1.142	21.13	0.8815	25.0	2.72	68.00	478.4	1.89
12	0.607	0.020	29.785	1.713	31.69	0.7135	23.5	2.56	67.50	561.2	1.89
16	0.605	0.024	25.395	2.284	42.25	0.6258	23.5	2.32	67.30	642.2	1.89
20	0.590	0.027	21.493	2.855	52.82	0.5768	22.5	2.00	65.64	730.4	3.28
24	0.590	0.032	18.599	3.426	63.38	0.5554	21.0	1.92	65.64	845.6	5.67
===== 12 =====											
ENGINE SPEED = 1000 RPM			PERCENT WATER = 45			INTAKE AIR TEMP. = 302 F					
LD	AIR	FUEL	A/F	C.BHP	BMEP	BSFC	INJ	ID	V.EFF	E.TEMP	% OP
8	0.561	0.017	33.518	1.142	21.12	0.8793	21.0	1.76	62.35	566.6	1.89
12	0.561	0.020	28.240	1.712	31.68	0.6956	21.5	1.76	62.34	651.2	1.89
16	0.552	0.024	23.016	2.283	42.24	0.6303	21.5	1.60	61.38	746.6	1.89
20	0.552	0.028	19.595	2.854	52.80	0.5931	21.0	1.56	61.47	847.4	1.89
24	0.547	0.034	15.886	3.425	63.36	0.6030	21.5	1.56	60.80	944.6	8.85
===== 13 =====											
ENGINE SPEED = 2000 RPM			PERCENT WATER = 0			INTAKE AIR TEMP. = 79 F					
LD	AIR	FUEL	A/F	C.BHP	BMEP	BSFC	INJ	ID	V.EFF	E.TEMP	% OP
8	1.431	0.034	41.577	2.275	21.05	0.9076	31.0	0.92	78.78	584.6	7.26
12	1.431	0.040	35.514	3.413	31.57	0.7084	31.0	0.92	78.78	662.0	10.25
16	1.426	0.047	30.538	4.551	42.10	0.6158	31.0	0.96	78.52	741.2	14.23
20	1.414	0.054	26.225	5.688	52.62	0.5687	32.0	0.92	77.81	833.0	17.61
24	1.410	0.061	22.966	6.826	63.14	0.5395	32.0	0.84	77.57	924.8	26.77
===== 14 =====											
ENGINE SPEED = 2000 RPM			PERCENT WATER = 0			INTAKE AIR TEMP. = 167 F					
LD	AIR	FUEL	A/F	C.BHP	BMEP	BSFC	INJ	ID	V.EFF	E.TEMP	% OP
8	1.228	0.035	37.808	2.276	21.06	0.9256	31.0	0.92	73.16	669.2	5.87
12	1.217	0.041	32.488	3.414	31.58	0.7122	31.0	0.88	72.55	743.0	6.86
16	1.210	0.048	27.500	4.552	42.11	0.6278	31.0	0.88	72.18	829.4	7.86
20	1.229	0.055	23.595	5.691	52.64	0.5805	31.0	0.84	71.58	933.8	11.84
24	1.208	0.064	20.464	6.829	63.17	0.5616	32.5	0.76	72.08	1031.0	37.71
===== 15 =====											
ENGINE SPEED = 2000 RPM			PERCENT WATER = 0			INTAKE AIR TEMP. = 302 F					
LD	AIR	FUEL	A/F	C.BHP	BMEP	BSFC	INJ	ID	V.EFF	E.TEMP	% OP
8	1.186	0.034	35.249	2.278	21.07	0.8863	32.5	0.92	65.47	723.2	6.86
12	1.190	0.041	29.986	3.417	31.61	0.7150	22.5	0.88	65.15	829.4	8.06
16	1.184	0.049	24.339	4.555	42.14	0.6410	32.5	0.84	65.39	960.8	12.64
20	1.176	0.057	20.519	5.694	52.68	0.6040	32.5	0.76	64.93	1068.8	16.82
24	1.176	0.072	16.437	6.834	63.21	0.6281	32.5	0.68	64.92	1247.0	49.05
===== 16 =====											
ENGINE SPEED = 2000 RPM			PERCENT WATER = 15			INTAKE AIR TEMP. = 81 F					
LD	AIR	FUEL	A/F	C.BHP	BMEP	BSFC	INJ	ID	V.EFF	E.TEMP	% OP
8	1.464	0.034	43.375	2.284	21.15	0.8865	30.0	1.32	81.45	537.8	1.89
12	1.270	0.039	32.419	3.427	31.70	0.6860	29.0	1.16	70.72	618.8	1.89
16	1.257	0.047	26.715	4.569	42.26	0.6181	30.0	1.20	70.01	707.0	1.89
20	1.427	0.054	26.548	5.709	52.81	0.5650	29.5	1.12	79.40	804.2	3.88
24	1.427	0.061	23.562	6.851	63.37	0.5305	30.0	1.12	79.40	906.8	11.84

TABLE III Continued

===== 17 =====											
ENGINE SPEED = 2000 RPM			PERCENT WATER = 15			INTAKE AIR TEMP. = 167 F					
LD	AIR	FUEL	A/F	C.BHP	BMEP	BSFC	INJ	ID	V.EFF	E.TEMP	% OP
8	1.331	0.034	39.427	2.286	21.15	0.8863	27.0	0.96	74.29	642.2	1.89
12	1.336	0.040	33.038	3.429	31.72	0.7074	28.0	0.96	74.53	714.2	1.89
16	1.316	0.048	27.677	4.572	42.29	0.6241	28.0	0.92	73.45	811.4	8.46
20	1.304	0.056	23.356	5.715	52.87	0.5859	28.0	0.96	72.73	923.0	10.85
24	1.298	0.063	20.445	6.858	63.43	0.5554	28.0	1.00	72.39	1018.4	15.02
===== 18 =====											
ENGINE SPEED = 2000 RPM			PERCENT WATER = 15			INTAKE AIR TEMP. = 302 F					
LD	AIR	FUEL	A/F	C.BHP	BMEP	BSFC	INJ	ID	V.EFF	E.TEMP	% OP
8	1.164	0.034	34.593	2.291	21.19	0.8813	30.0	0.88	65.31	728.6	1.89
12	1.160	0.041	28.326	3.436	31.78	0.7151	28.5	0.84	65.09	833.0	1.89
16	1.150	0.049	23.381	4.581	42.38	0.6441	28.5	0.80	64.52	957.2	9.65
20	1.141	0.059	19.495	5.727	52.97	0.6134	28.5	0.80	64.05	1108.4	27.56
24	1.129	0.073	15.433	6.877	63.61	0.6382	28.5	0.80	63.47	1259.6	58.01
===== 19 =====											
ENGINE SPEED = 2000 RPM			PERCENT WATER = 30			INTAKE AIR TEMP. = 88 F					
LD	AIR	FUEL	A/F	C.BHP	BMEP	BSFC	INJ	ID	V.EFF	E.TEMP	% OP
8	1.398	0.033	42.601	2.294	21.22	0.8579	30.0	2.12	78.78	514.4	1.89
12	1.424	0.038	37.346	3.442	31.84	0.6648	30.0	2.04	80.31	590.0	1.89
16	1.410	0.045	31.086	4.590	42.46	0.5930	29.0	1.96	79.54	680.0	4.28
20	1.404	0.052	27.093	5.737	53.07	0.5418	30.0	1.92	79.18	761.0	4.28
24	1.387	0.059	23.471	6.885	63.69	0.5150	28.5	1.72	78.24	861.8	5.07
===== 20 =====											
ENGINE SPEED = 2000 RPM			PERCENT WATER = 30			INTAKE AIR TEMP. = 167 F					
LD	AIR	FUEL	A/F	C.BHP	BMEP	BSFC	INJ	ID	V.EFF	E.TEMP	% OP
8	1.309	0.033	39.149	2.292	21.20	0.8756	29.0	2.04	73.59	591.8	1.89
12	1.303	0.039	33.110	3.438	31.80	0.6869	29.0	1.92	73.25	680.0	1.89
16	1.301	0.046	28.044	4.584	42.40	0.6073	27.0	1.92	73.12	760.8	1.89
20	1.303	0.054	24.036	5.730	53.00	0.5677	27.0	1.56	73.25	888.8	5.81
24	1.278	0.062	20.540	6.876	63.60	0.5430	26.5	1.52	71.84	996.8	12.87
===== 21 =====											
ENGINE SPEED = 2000 RPM			PERCENT WATER = 30			INTAKE AIR TEMP. = 302 F					
LD	AIR	FUEL	A/F	C.BHP	BMEP	BSFC	INJ	ID	V.EFF	E.TEMP	% OP
8	1.171	0.034	34.148	2.289	21.18	0.8990	27.0	1.00	65.64	734.0	1.89
12	1.159	0.042	27.580	3.434	31.77	0.7343	26.0	1.00	64.95	836.6	2.89
16	1.151	0.050	23.026	4.579	42.36	0.6548	26.0	1.00	64.47	957.2	4.48
20	1.147	0.060	19.092	5.724	52.94	0.6274	26.0	0.92	64.02	1106.6	19.80
24	1.128	0.074	15.328	6.868	63.53	0.6488	26.0	0.92	63.79	1230.8	41.09
===== 22 =====											
ENGINE SPEED = 2000 RPM			PERCENT WATER = 45			INTAKE AIR TEMP. = 83 F					
LD	AIR	FUEL	A/F	C.BHP	BMEP	BSFC	INJ	ID	V.EFF	E.TEMP	% OP
8	1.459	0.036	40.033	2.295	21.13	0.9574	40.0	2.64	81.27	496.4	1.89
12	1.453	0.041	35.049	3.427	31.70	0.7257	38.0	2.52	80.89	570.2	1.89
16	1.442	0.047	30.742	4.569	42.27	0.6160	37.0	2.56	80.31	645.8	1.89
20	1.442	0.053	27.153	5.711	52.83	0.5580	34.0	2.24	80.31	716.0	2.89
24	1.429	0.061	23.557	6.854	63.40	0.5312	32.0	2.08	79.59	813.2	2.89

TABLE III Continued

===== 23 =====											
ENGINE SPEED = 2000 RPM				PERCENT WATER = 45				INTAKE AIR TEMP. = 167 F			
LD	AIR	FUEL	A/F	C.BHP	BMEP	BSFC	INJ	ID	V.EFF	E.TEMP	% OP
8	1.347	0.036	37.447	2.284	21.13	0.9448	33.0	2.00	74.92	579.2	1.89
12	1.345	0.041	32.634	3.426	31.69	0.7216	33.0	2.00	74.80	645.8	1.89
16	1.338	0.046	29.025	4.568	42.25	0.6056	32.0	1.92	74.44	714.2	1.89
20	1.336	0.055	24.085	5.710	52.82	0.5828	29.0	1.76	74.31	816.8	3.88
24	1.331	0.063	21.075	6.851	63.38	0.5533	29.0	1.64	74.07	930.2	5.87
===== 24 =====											
ENGINE SPEED = 2000 RPM				PERCENT WATER = 45				INTAKE AIR TEMP. = 302 F			
LD	AIR	FUEL	A/F	C.BHP	BMEP	BSFC	INJ	ID	V.EFF	E.TEMP	% OP
8	1.232	0.035	34.797	2.277	21.07	0.9324	25.5	1.96	67.97	707.0	5.87
12	1.219	0.043	28.629	3.416	31.60	0.7476	25.5	1.84	67.26	807.8	8.85
16	1.208	0.049	24.495	4.555	42.14	0.6496	25.0	1.84	66.67	917.6	9.85
20	1.206	0.060	20.251	5.694	52.67	0.6278	25.0	1.72	66.58	1045.4	9.85
24	1.189	0.074	16.164	6.832	63.20	0.6462	25.0	1.68	65.64	1189.4	22.79
===== 25 =====											
ENGINE SPEED = 1000 RPM				PERCENT WATER = 0				INTAKE AIR TEMP. = 88 F			
LD	AIR	FUEL	A/F	C.BHP	BMEP	BSFC	INJ	ID	V.EFF	E.TEMP	% OP
16	0.680	0.022	30.728	2.264	41.88	0.5864	23.0	0.00	73.74	324.0	0.00
16	0.680	0.022	30.703	2.264	41.88	0.5869	23.0	0.00	73.74	324.0	0.00
16	0.680	0.022	30.796	2.264	41.88	0.5851	23.0	0.00	73.74	324.0	0.00
16	0.680	0.022	30.678	2.264	41.88	0.5873	23.0	0.00	73.74	324.0	0.00
20	0.676	0.026	25.965	2.831	52.37	0.5521	23.0	0.00	73.42	377.0	0.00
20	0.676	0.026	25.977	2.831	52.37	0.5518	23.0	0.00	73.42	377.0	0.00
20	0.676	0.026	25.977	2.831	52.37	0.5518	23.0	0.00	73.42	377.0	0.00
20	0.676	0.026	25.939	2.831	52.37	0.5505	23.0	0.00	73.42	377.0	0.00
24	0.674	0.031	21.903	3.397	62.85	0.5435	23.0	0.00	73.17	431.0	0.00
24	0.674	0.031	21.976	3.397	62.85	0.5417	23.0	0.00	73.17	431.0	0.00
24	0.674	0.031	22.043	3.397	62.85	0.5401	23.0	0.00	73.17	431.0	0.00
24	0.674	0.031	21.933	3.397	62.85	0.5428	23.0	0.00	73.17	431.0	0.00
===== 26 =====											
ENGINE SPEED = 1000 RPM				PERCENT WATER = 15				INTAKE AIR TEMP. = 88 F			
LD	AIR	FUEL	A/F	C.BHP	BMEP	BSFC	INJ	ID	V.EFF	E.TEMP	% OP
16	0.672	0.022	29.885	2.267	41.94	0.5951	24.0	0.00	73.13	317.0	0.00
16	0.672	0.023	29.833	2.267	41.94	0.5961	24.0	0.00	73.13	317.0	0.00
16	0.672	0.023	29.818	2.267	41.94	0.5964	24.0	0.00	73.13	317.0	0.00
16	0.672	0.023	29.818	2.267	41.94	0.5964	24.0	0.00	73.13	317.0	0.00
20	0.672	0.027	25.046	2.833	52.42	0.5681	24.0	0.00	73.13	371.0	0.00
20	0.672	0.027	25.046	2.833	52.42	0.5681	24.0	0.00	73.13	371.0	0.00
20	0.672	0.027	25.061	2.833	52.42	0.5677	24.0	0.00	73.13	371.0	0.00
20	0.672	0.027	25.179	2.833	52.42	0.5651	24.0	0.00	73.13	371.0	0.00
24	0.672	0.031	21.494	3.400	62.90	0.5516	24.0	0.00	73.13	426.0	0.00
24	0.672	0.031	21.457	3.400	62.90	0.5526	24.0	0.00	73.13	426.0	0.00
24	0.672	0.031	21.479	3.400	62.90	0.5520	24.0	0.00	73.13	426.0	0.00
24	0.672	0.031	21.465	3.400	62.90	0.5524	24.0	0.00	73.13	426.0	0.00

TABLE III Continued

===== 27 =====											
ENGINE SPEED = 1000 RPM				PERCENT WATER = 30				INTAKE AIR TEMP. = 88 F			
LD	AIR	FUEL	A/F	C.BHP	BMEP	BSFC	INJ	ID	V.EFF	E.TEMP	% OP
16	0.672	0.023	29.125	2.267	41.94	0.6106	24.0	0.00	73.13	312.0	0.00
16	0.672	0.023	29.144	2.267	41.94	0.6102	24.0	0.00	73.13	312.0	0.00
16	0.672	0.023	29.144	2.267	41.94	0.6102	24.0	0.00	73.13	312.0	0.00
16	0.672	0.023	29.061	2.267	41.94	0.6120	24.0	0.00	73.13	312.0	0.00
20	0.672	0.027	24.747	2.833	52.42	0.5749	24.0	0.00	73.13	371.0	0.00
20	0.672	0.027	24.710	2.833	52.42	0.5758	24.0	0.00	73.13	371.0	0.00
20	0.672	0.027	24.720	2.833	52.42	0.5756	24.0	0.00	73.13	371.0	0.00
20	0.672	0.027	24.701	2.833	52.42	0.5760	24.0	0.00	73.13	371.0	0.00
24	0.672	0.032	21.273	3.400	62.90	0.5574	24.0	0.00	73.13	428.0	0.00
24	0.672	0.032	21.291	3.400	62.90	0.5569	24.0	0.00	73.13	428.0	0.00
24	0.672	0.032	21.263	3.400	62.90	0.5576	24.0	0.00	73.13	428.0	0.00
24	0.672	0.032	21.162	3.400	62.90	0.5603	24.0	0.00	73.13	428.0	0.00

===== 28 =====											
ENGINE SPEED = 2000 RPM				PERCENT WATER = 0				INTAKE AIR TEMP. = 88 F			
LD	AIR	FUEL	A/F	C.BHP	BMEP	BSFC	INJ	ID	V.EFF	E.TEMP	% OP
16	1.491	0.046	32.108	4.546	42.05	0.6130	30.0	0.00	81.83	375.0	0.00
16	1.491	0.046	32.142	4.546	42.05	0.6123	30.0	0.00	81.83	375.0	0.00
16	1.491	0.046	32.155	4.546	42.05	0.6121	30.0	0.00	81.83	375.0	0.00
16	1.491	0.046	32.155	4.546	42.05	0.6121	30.0	0.00	81.83	375.0	0.00
20	1.478	0.054	27.304	5.685	52.59	0.5714	30.0	0.00	81.23	428.0	0.00
20	1.478	0.054	27.311	5.685	52.59	0.5713	30.0	0.00	81.23	428.0	0.00
20	1.478	0.054	27.358	5.685	52.59	0.5703	30.0	0.00	81.23	428.0	0.00
20	1.478	0.054	27.351	5.685	52.59	0.5704	30.0	0.00	81.23	428.0	0.00
24	1.469	0.062	23.654	6.822	63.10	0.5464	30.0	0.00	80.74	486.0	0.00
24	1.469	0.062	23.674	6.822	63.10	0.5459	30.0	0.00	80.74	486.0	0.00
24	1.469	0.062	23.674	6.822	63.10	0.5459	30.0	0.00	80.74	486.0	0.00
24	1.469	0.062	23.714	6.822	63.10	0.5450	30.0	0.00	80.74	486.9	0.00

===== 29 =====											
ENGINE SPEED = 2000 RPM				PERCENT WATER = 15				INTAKE AIR TEMP. = 88 F			
LD	AIR	FUEL	A/F	C.BHP	BMEP	BSFC	INJ	ID	V.EFF	E.TEMP	% OP
16	1.484	0.046	32.599	4.549	42.08	0.6004	31.0	0.00	81.64	356.0	0.00
16	1.484	0.046	32.542	4.549	42.08	0.6015	31.0	0.00	81.64	356.0	0.00
16	1.484	0.046	32.665	4.549	42.08	0.5992	31.0	0.00	81.64	356.0	0.00
16	1.484	0.046	32.379	4.549	42.08	0.6045	31.0	0.00	81.64	356.0	0.00
20	1.475	0.053	27.928	5.687	52.60	0.5573	31.5	0.00	81.15	405.0	0.00
20	1.475	0.053	27.904	5.687	52.60	0.5578	31.5	0.00	81.15	405.0	0.00
20	1.475	0.053	27.863	5.687	52.60	0.5586	31.5	0.00	81.15	405.0	0.00
20	1.475	0.053	27.879	5.687	52.60	0.5583	31.5	0.00	81.15	405.0	0.00
24	1.466	0.060	24.482	6.824	63.13	0.5266	32.0	0.00	80.66	462.0	0.00
24	1.466	0.060	24.522	6.824	63.13	0.5258	32.0	0.00	80.66	462.0	0.00
24	1.466	0.060	24.474	6.824	63.13	0.5268	32.0	0.00	80.66	462.0	0.00
24	1.466	0.060	24.522	6.824	63.13	0.5258	32.0	0.00	80.66	462.0	0.00

===== 30 =====											
ENGINE SPEED = 2000 RPM				PERCENT WATER = 30				INTAKE AIR TEMP. = 88 F			
LD	AIR	FUEL	A/F	C.BHP	BMEP	BSFC	INJ	ID	V.EFF	E.TEMP	% OP
16	1.475	0.046	32.381	4.549	42.08	0.6009	32.0	0.00	81.15	343.0	0.00
16	1.475	0.046	32.148	4.549	42.08	0.6052	32.0	0.00	81.15	343.0	0.00
16	1.475	0.046	32.108	4.549	42.08	0.6060	32.0	0.00	81.15	343.0	0.00
16	1.475	0.046	32.179	4.549	42.08	0.6046	32.0	0.00	81.15	343.0	0.00
20	1.466	0.053	27.690	5.687	52.60	0.5587	32.0	0.00	80.66	391.0	0.00
20	1.466	0.053	27.720	5.687	52.60	0.5581	32.0	0.00	80.66	391.0	0.00
20	1.466	0.053	27.750	5.687	52.60	0.5575	32.0	0.00	80.66	391.0	0.00
20	1.466	0.053	27.630	5.687	52.60	0.5600	32.0	0.00	80.66	391.0	0.00
24	1.458	0.061	24.053	6.824	63.13	0.5328	32.0	0.00	80.17	443.0	0.00
24	1.458	0.061	24.023	6.824	63.13	0.5334	32.0	0.00	80.17	443.0	0.00
24	1.458	0.061	23.993	6.824	63.13	0.5341	32.0	0.00	80.17	443.0	0.00
24	1.458	0.061	24.033	6.824	63.13	0.5322	32.0	0.00	80.17	443.0	0.00

TABLE IV

COMPUTER PRINTOUT OF THE CYLINDER PRESSURE
AND NEEDLE LIFT DIGITIZED DATA POINTS

----- DATA CORRESPONDS TO 71724IM.ASC -----

I	NL(I)	SNL(I)	CP(I)	SCP(I)
192	241	-1	24	6
193	240	0	30	5
194	240	0	35	6
195	240	1	41	7
196	241	0	45	7
197	241	-1	55	7
198	240	0	62	8
199	240	0	70	8
200	240	0	78	9
201	240	0	87	9
202	240	1	96	10
203	241	0	106	10
204	241	0	116	11
205	241	0	127	11
206	241	1	138	12
207	242	0	150	13
208	242	1	163	13
209	243	1	175	14
210	244	0	190	15
211	244	0	205	15
212	244	0	220	17
213	244	-1	237	17
214	243	1	254	19
215	244	0	273	19
216	244	0	292	21
217	244	0	313	21
218	244	3	334	22
219	247	2	356	24
220	249	2	380	24
221	251	4	404	26
222	253	5	430	26
223	250	4	456	28
224	254	3	484	29
225	257	8	512	29
226	275	28	541	31
227	303	62	572	31
228	365	90	603	30
229	455	111	633	31
230	566	134	664	31
231	700	157	695	29
232	857	191	724	29
233	1048	237	753	26
234	1285	267	779	33
235	1552	42	812	21
236	1594	-37	833	20
237	1557	57	853	30
238	1614	-32	883	23
239	1582	18	906	22
240	1600	-10	928	32
241	1590	-3	960	71
242	1587	3	1031	101
243	1590	-11	1132	174
244	1579	-15	1306	133
245	1564	-31	1439	184
246	1533	-45	1623	62
247	1488	-53	1685	3
248	1435	-83	1688	18

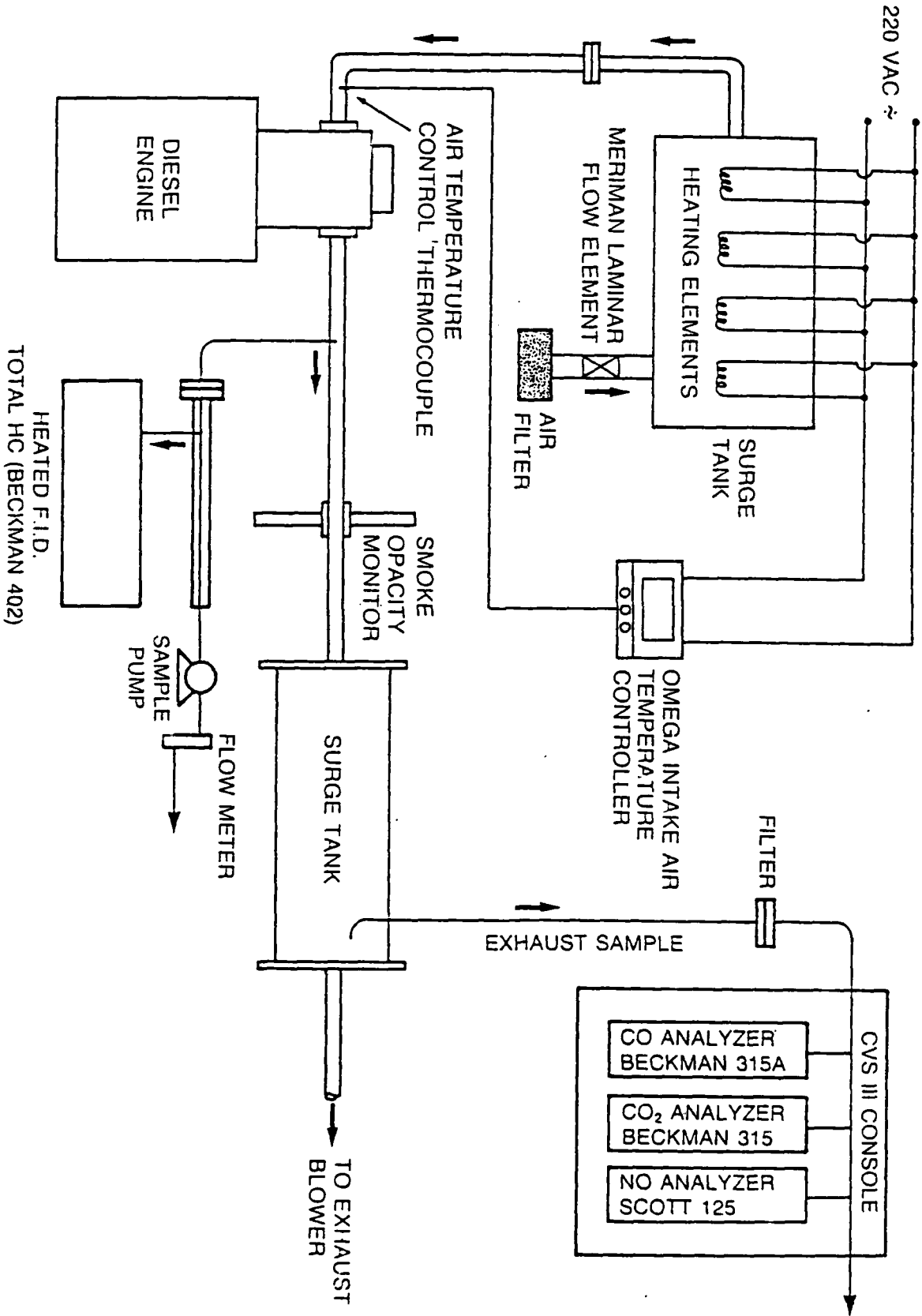

FIGURE 1 SCHEMATIC OF ENGINE INTAKE, EXHAUST AND EMISSION SYSTEMS

HEATED F.I.D.
TOTAL HC (BECKMAN 402)

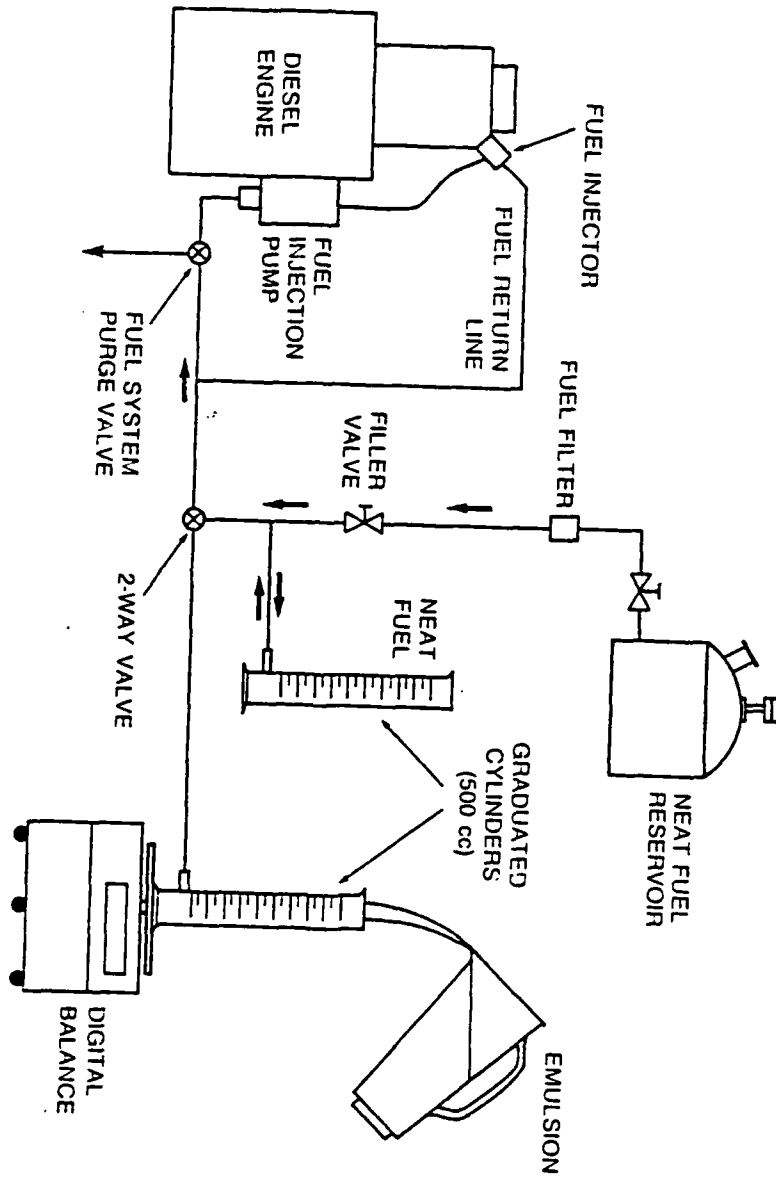

FIGURE 2 SCHEMATIC OF THE FUEL DELIVERY SYSTEM

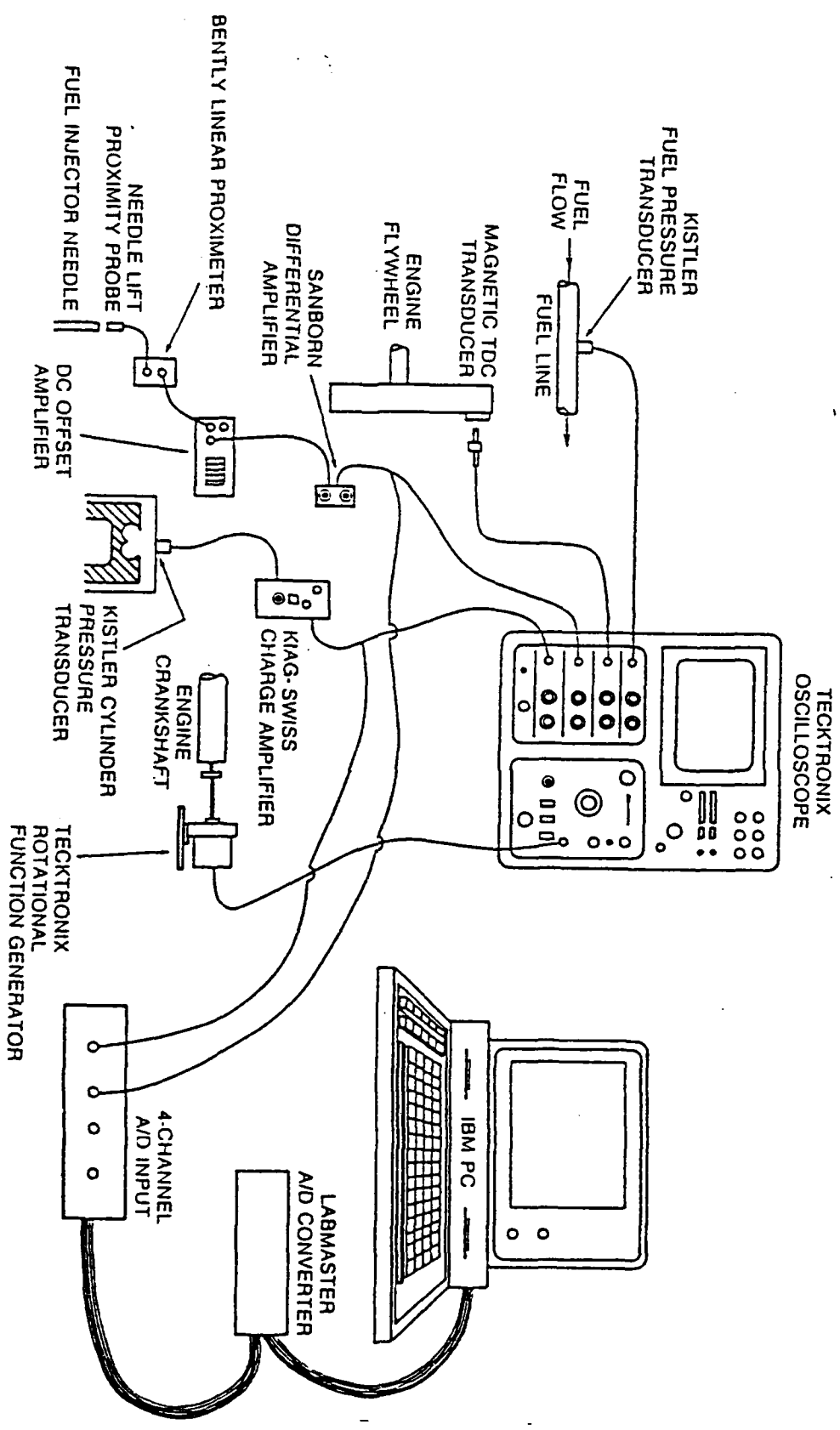

FIGURE 3 SCHEMATIC OF THE COMBUSTION INSTRUMENTATION

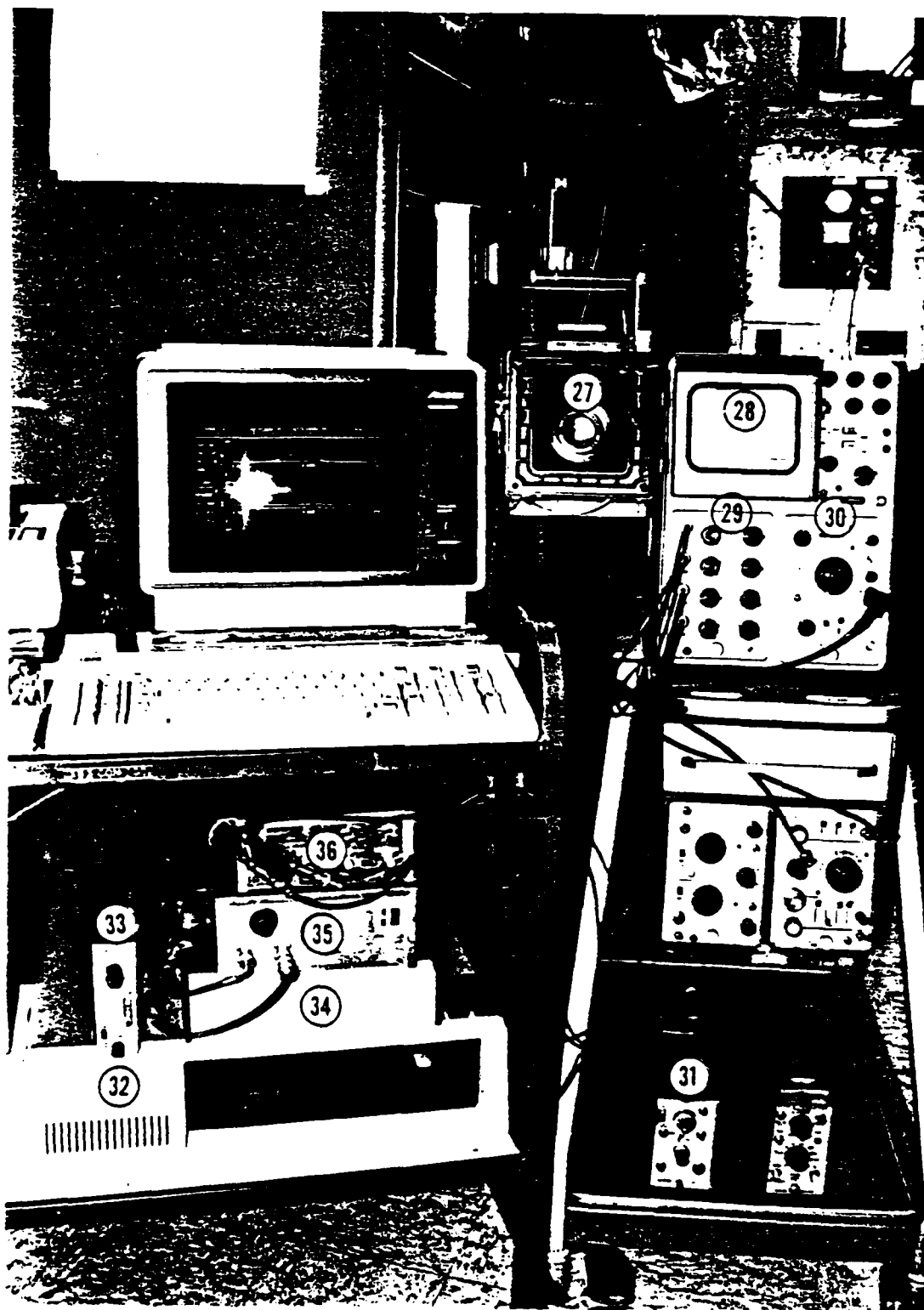

FIGURE 4 PHOTOGRAPH OF THE COMBUSTION DIAGNOSTIC INSTRUMENTATION USED TO DETERMINE THE IGNITION DELAY PERIOD

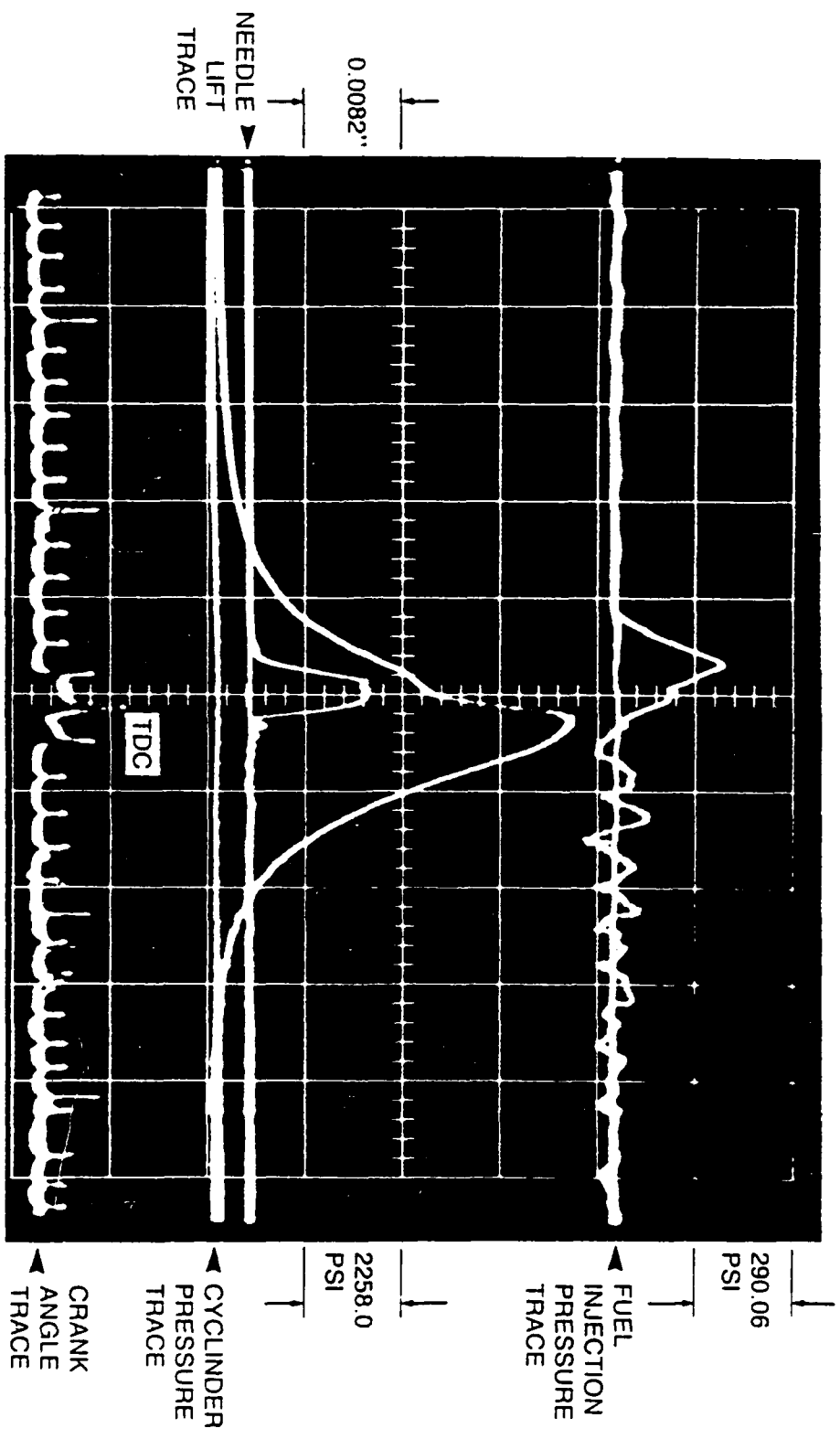

FIGURE 5 PHOTOGRAPH OF THE CYLINDER PRESSURE, NEEDLE LIFT, FUEL PRESSURE, AND DEGREES CRANK ANGLE SIGNALS ON THE TEKTRONIX OSCILLOSCOPE

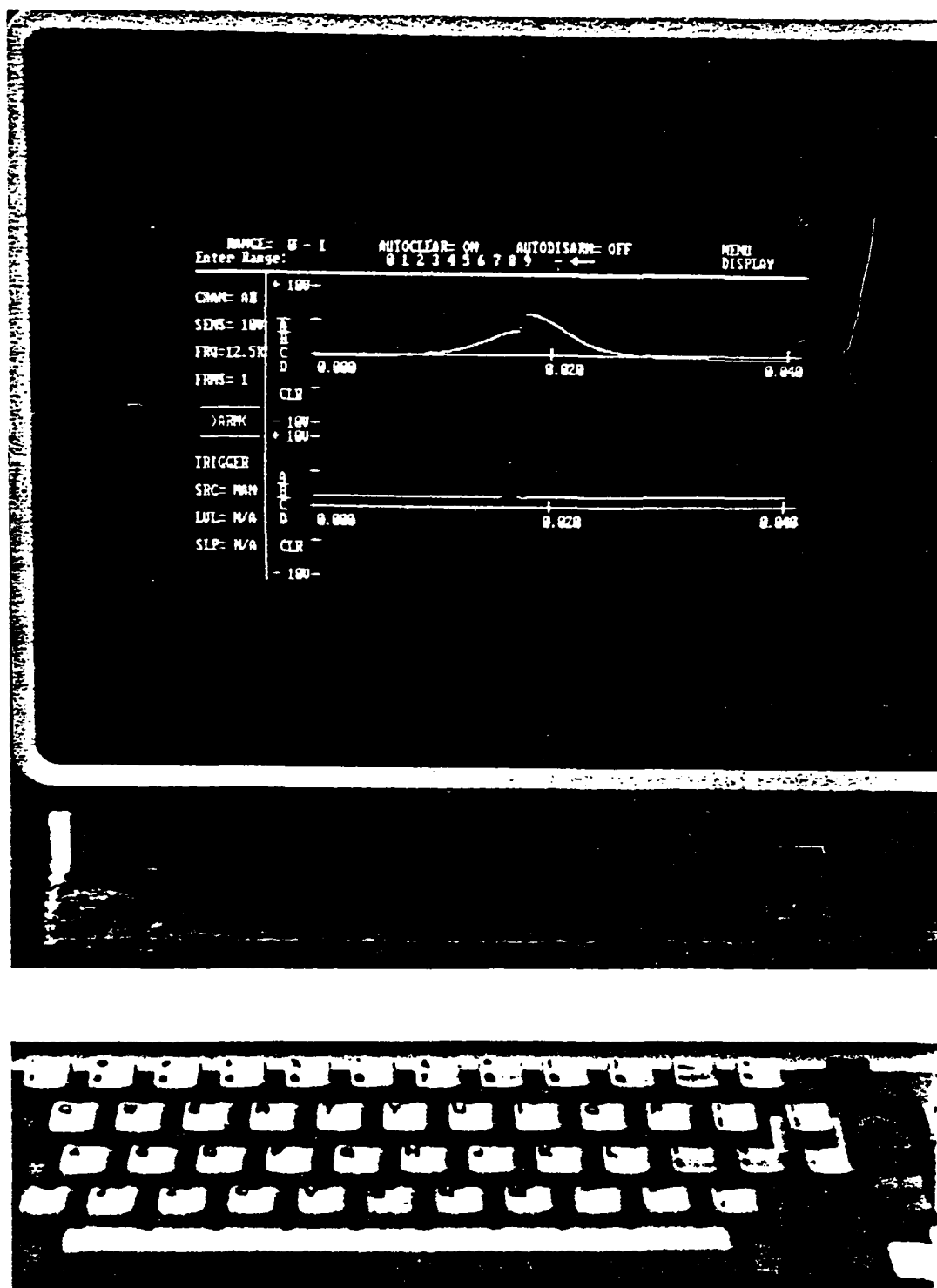

FIGURE 6 PHOTOGRAPH OF THE NEEDLE LIFT AND CYLINDER
 PRESSURE DIGITIZED SIGNALS ON THE COMPUTER
 SCREEN

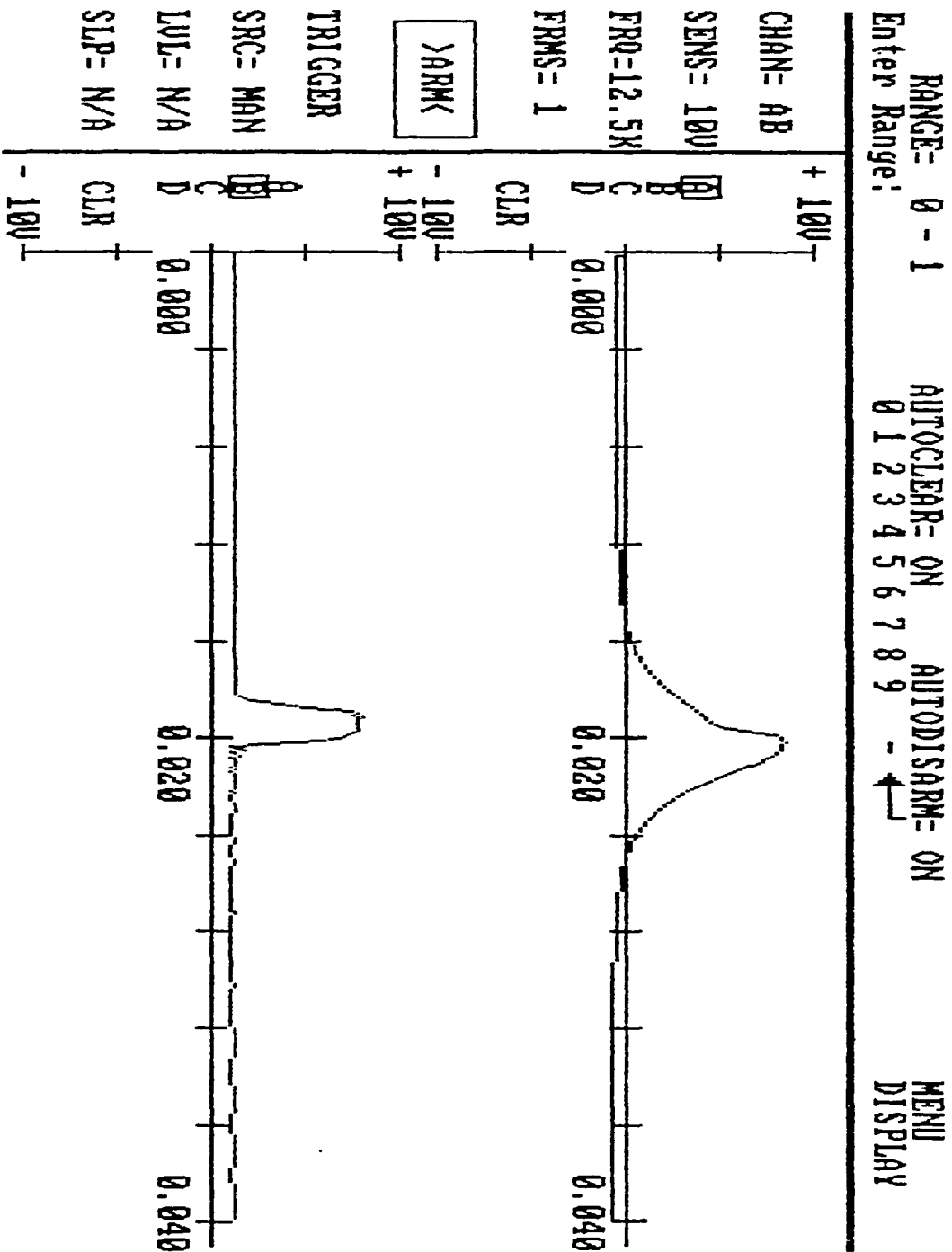

FIGURE 7 IBM PC COMPUTER PLOT OF THE CYLINDER PRESSURE AND NEEDLE LIFT SIGNALS

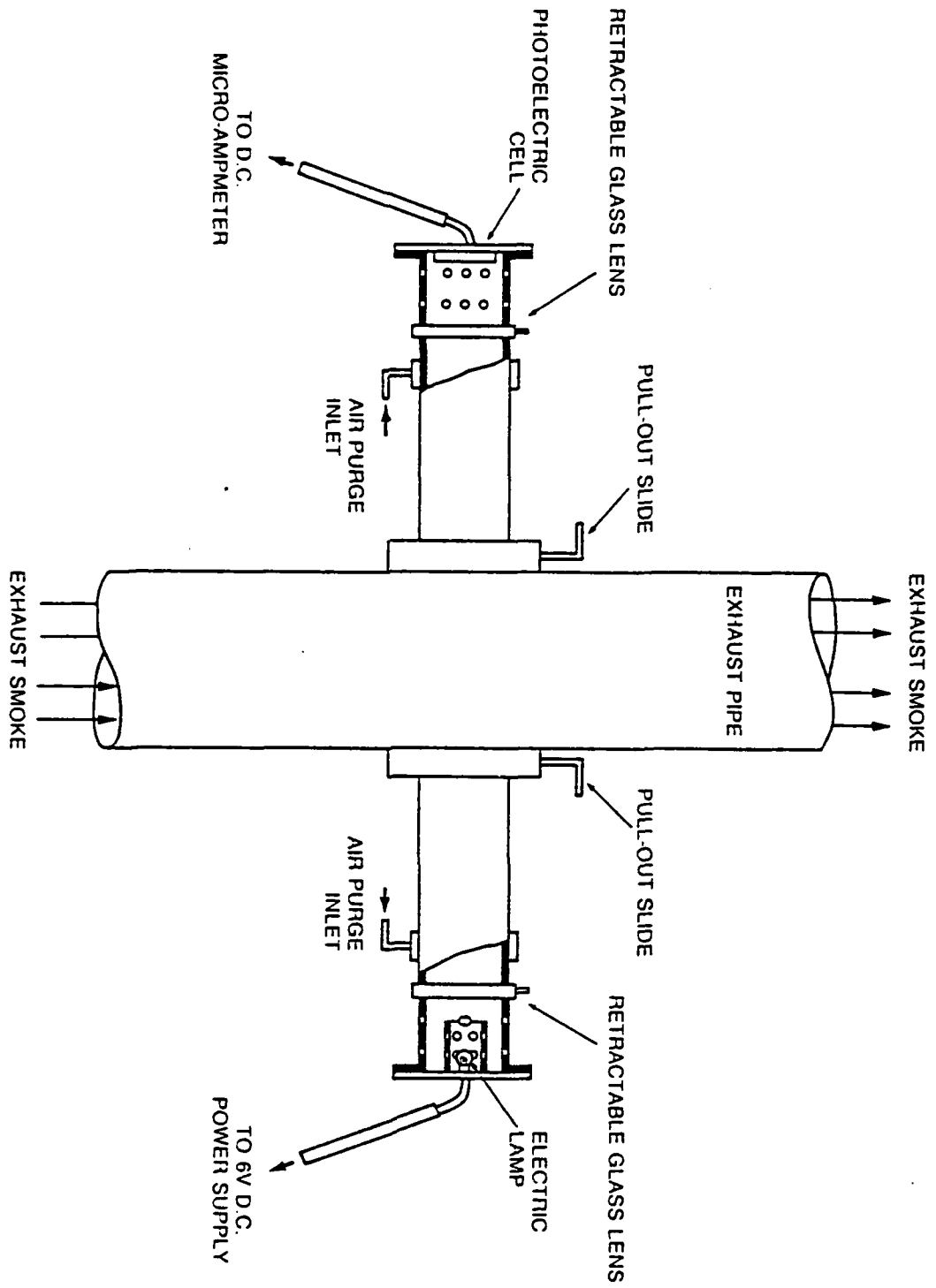

FIGURE 8 SCHEMATIC OF THE SMOKE MONITOR

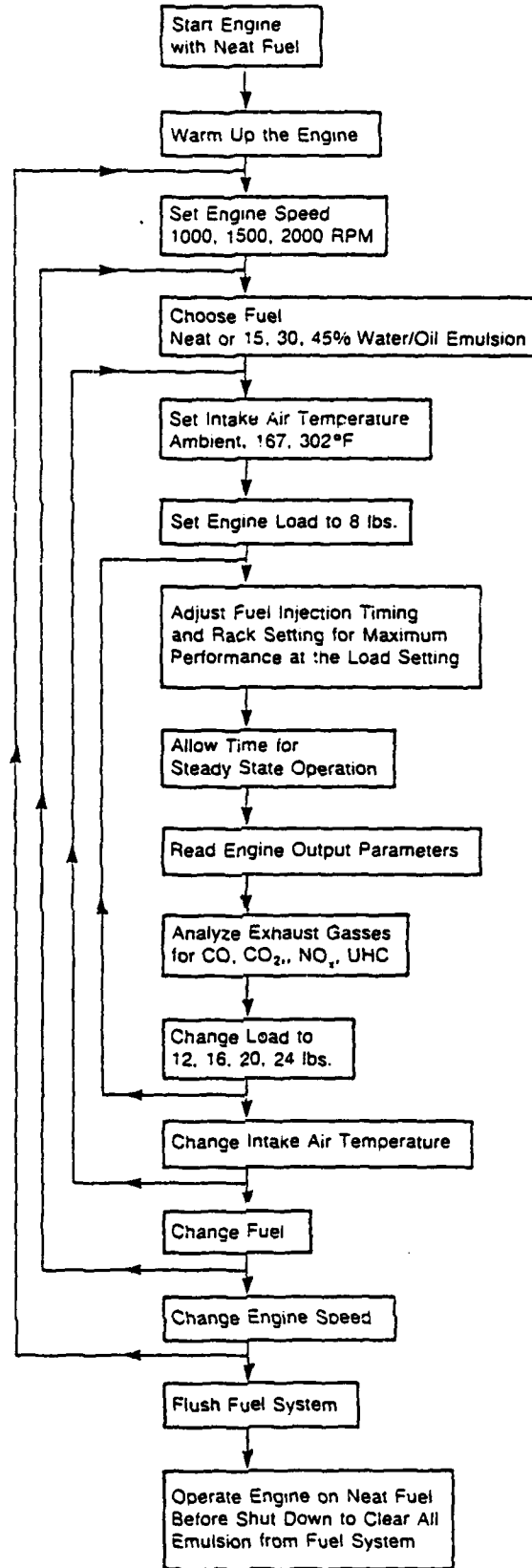

FIGURE 9 FLOW CHART OF TESTING PROGRAM

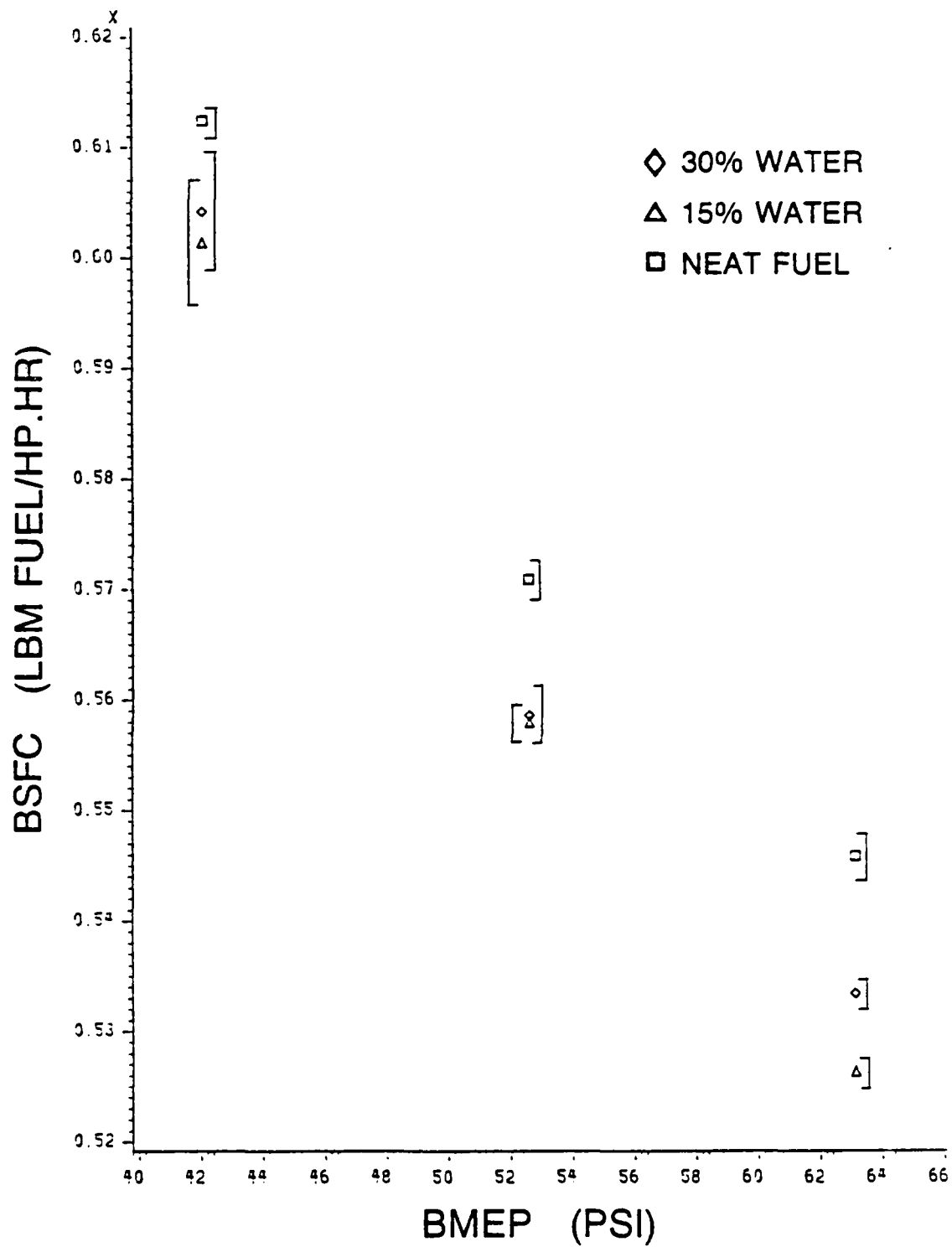

FIGURE 10 EFFECT OF WATER / OIL EMULSIONS ON THE BSFC FOR AN INTAKE AIR TEMPERATURE OF 88.0 F AT 2000 RPM

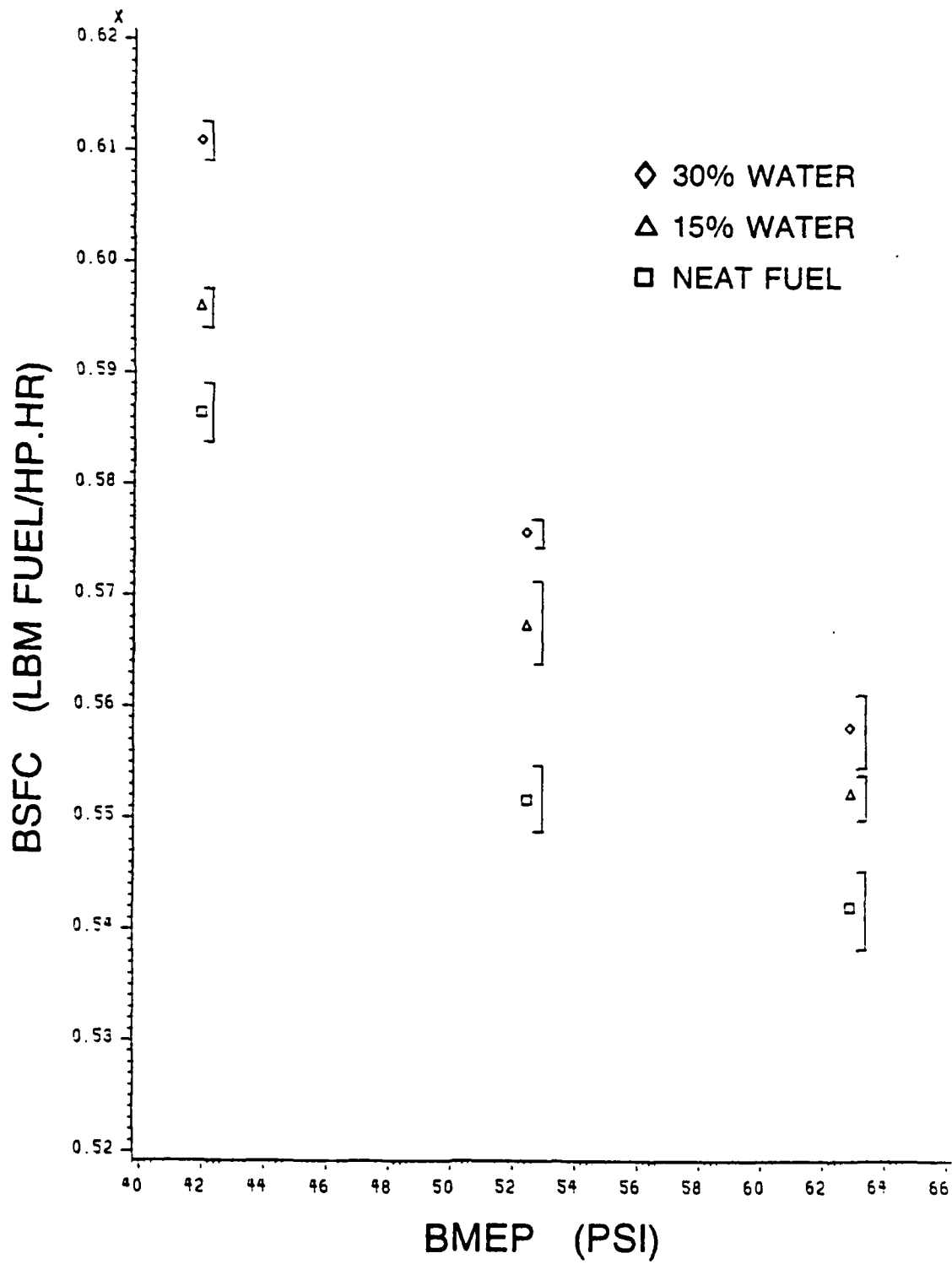

FIGURE 11 EFFECT OF WATER / OIL EMULSIONS ON THE BSFC FOR AN INTAKE AIR TEMPERATURE OF 88.0 F AT 1000 RPM

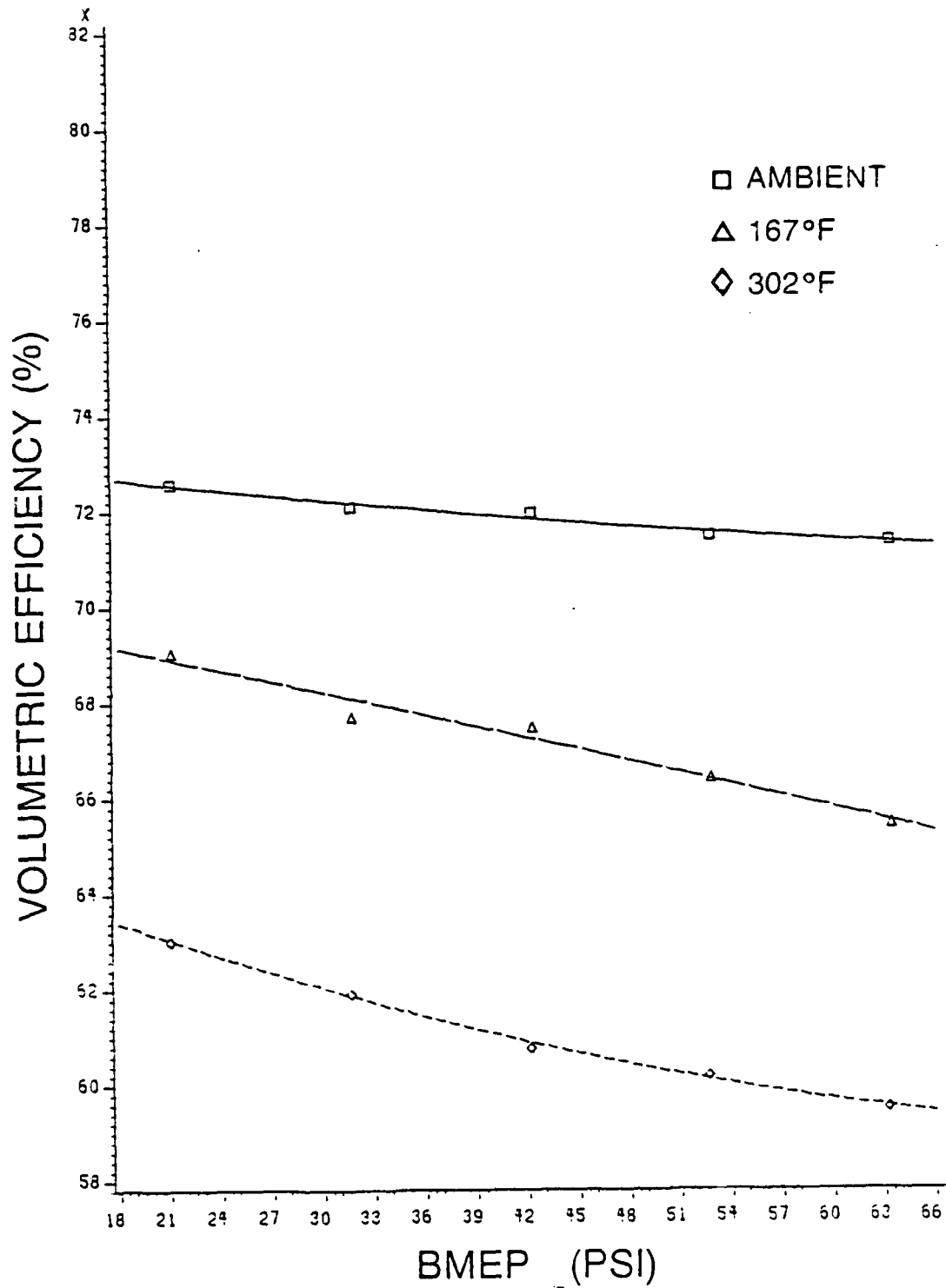

FIGURE 12 EFFECT OF ENGINE LOAD AND INTAKE AIR TEMPERATURE ON THE VOLUMETRIC EFFICIENCY FOR NEAT FUEL AT 1000 RPM

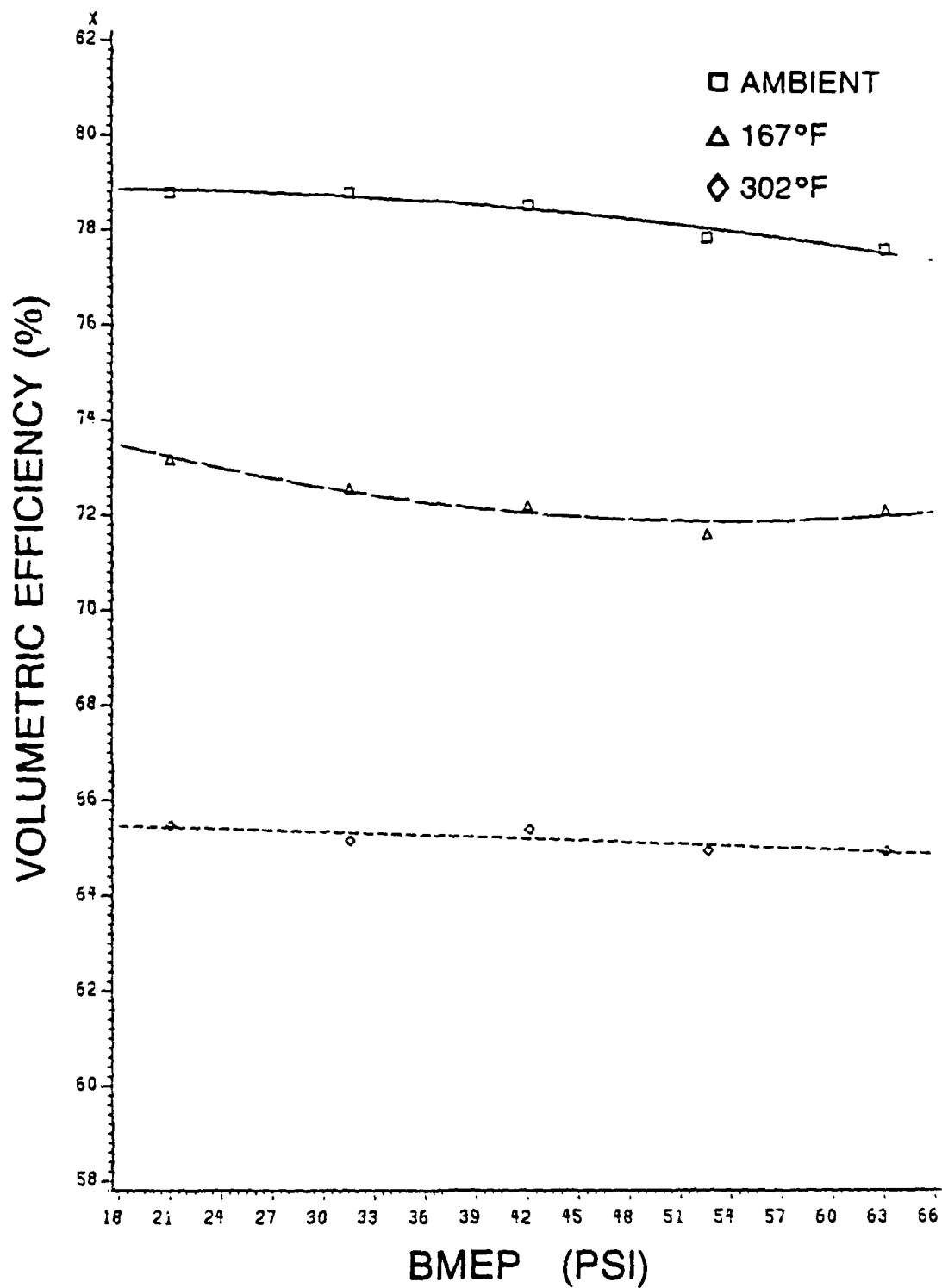

FIGURE 13 EFFECT OF ENGINE LOAD AND INTAKE AIR TEMPERATURE ON THE VOLUMETRIC EFFICIENCY FOR NEAT FUEL AT 2000 RPM

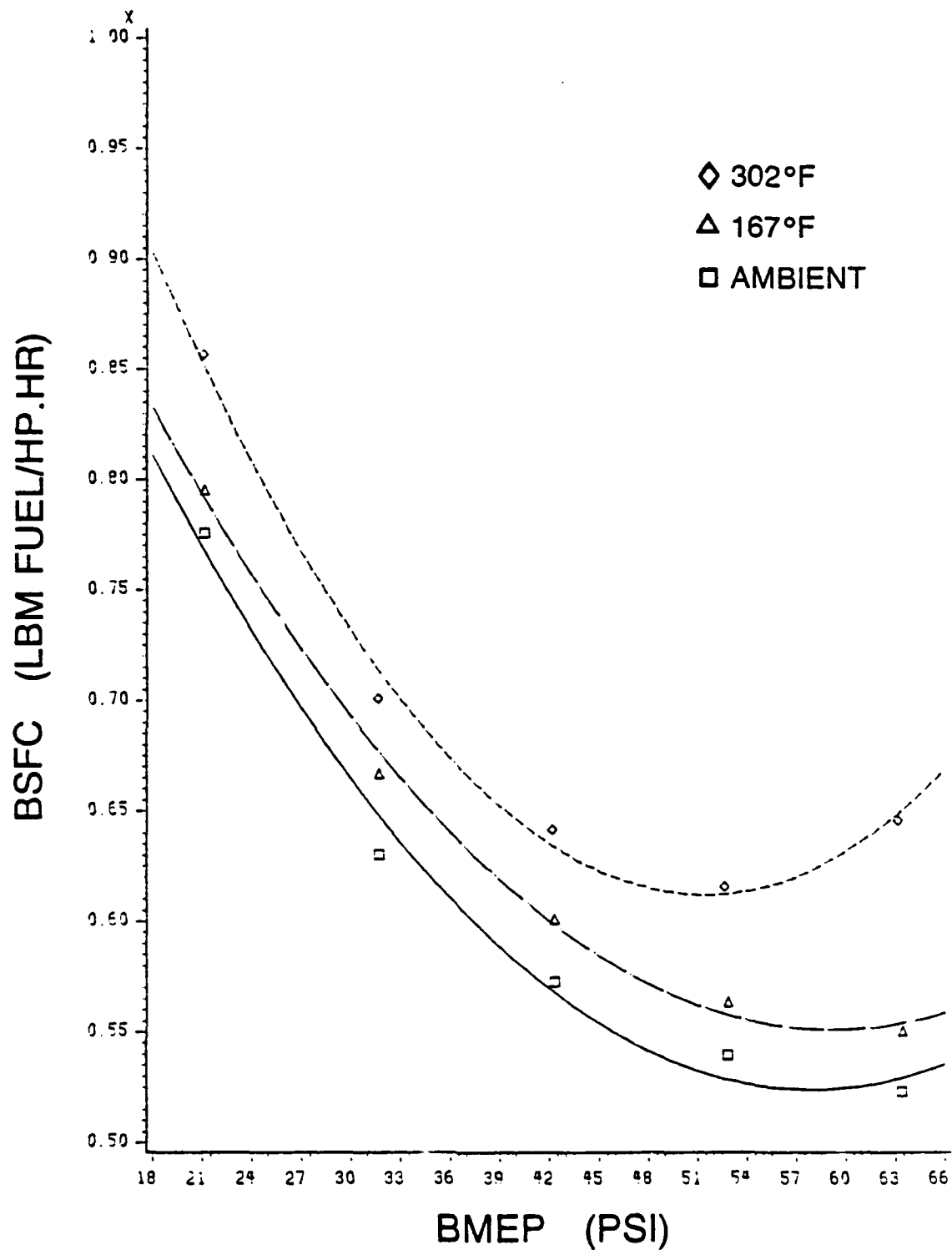

FIGURE 14 EFFECT OF ENGINE LOAD AND INTAKE AIR TEMPERATURE ON THE BSFC FOR NEAT FUEL AT 1000 RPM

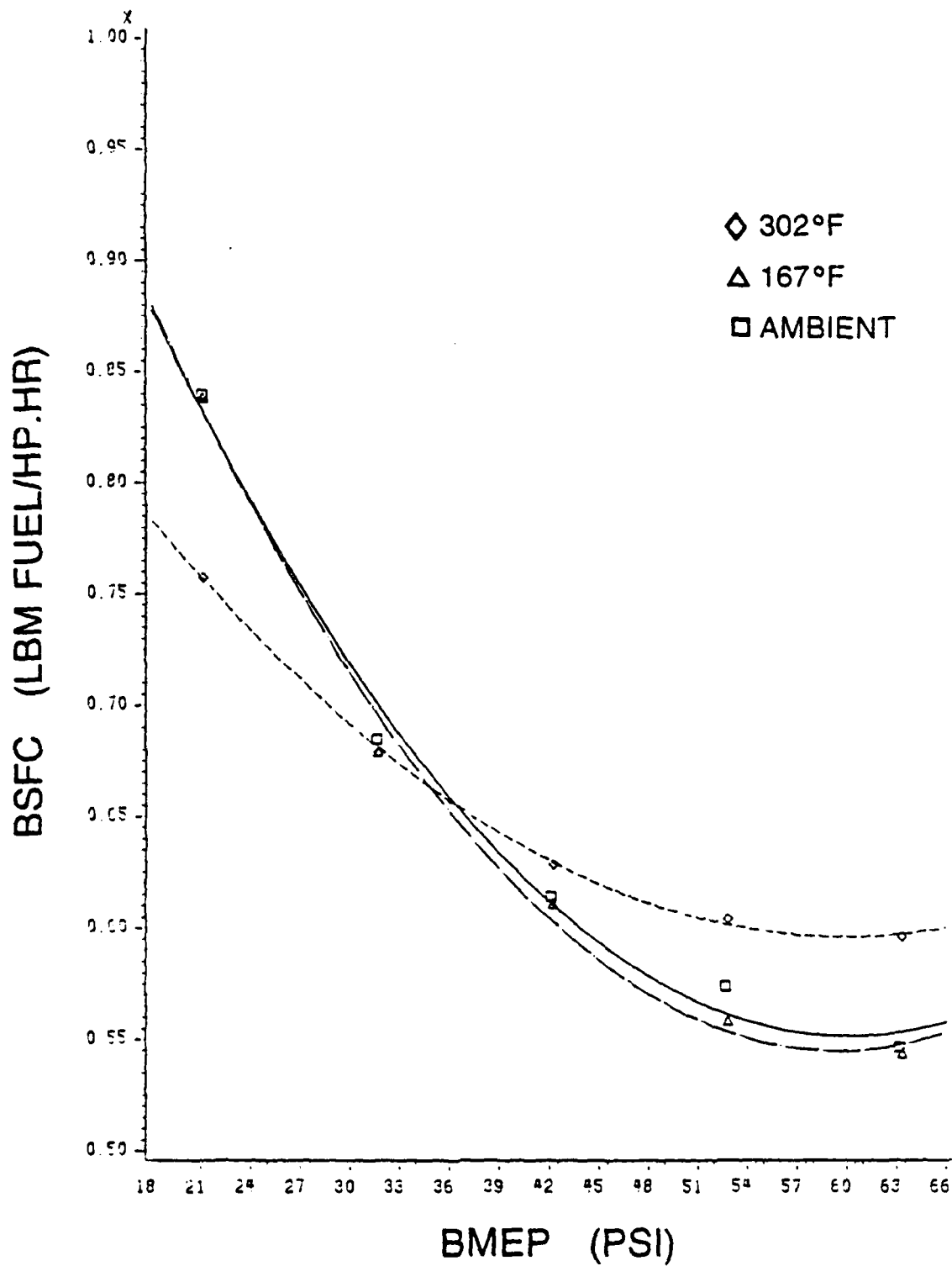

FIGURE 15 EFFECT OF ENGINE LOAD AND INTAKE AIR TEMPERATURE ON THE BSFC FOR 15 % WATER / OIL EMULSION AT 1000 RPM

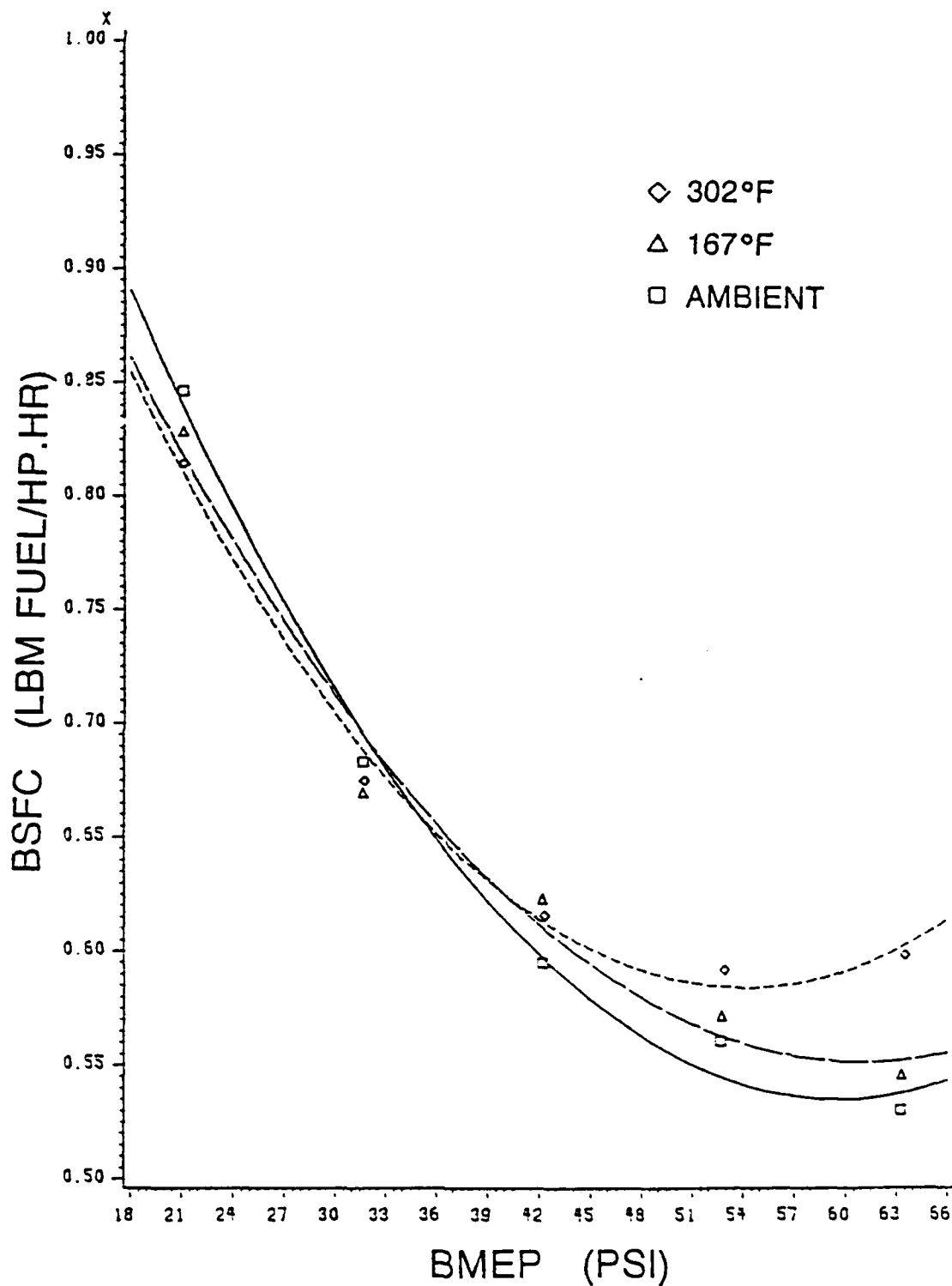

FIGURE 16 EFFECT OF ENGINE LOAD AND INTAKE AIR TEMPERATURE ON THE BSFC FOR 30 % WATER / OIL EMULSION AT 1000 RPM

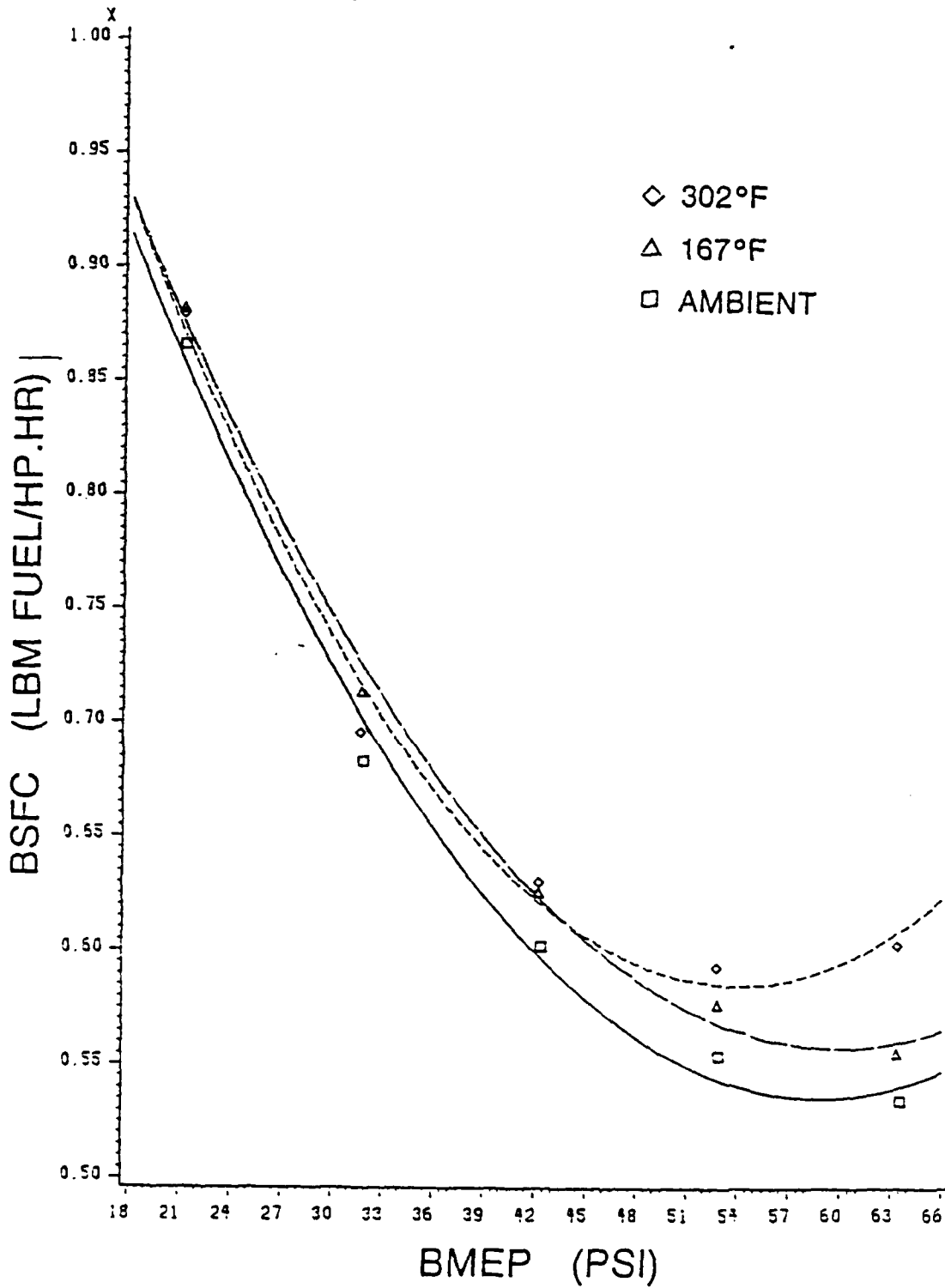

FIGURE 17 EFFECT OF ENGINE LOAD AND INTAKE AIR TEMPERATURE ON THE BSFC FOR 45 % WATER / OIL EMULSION AT 1000 RPM

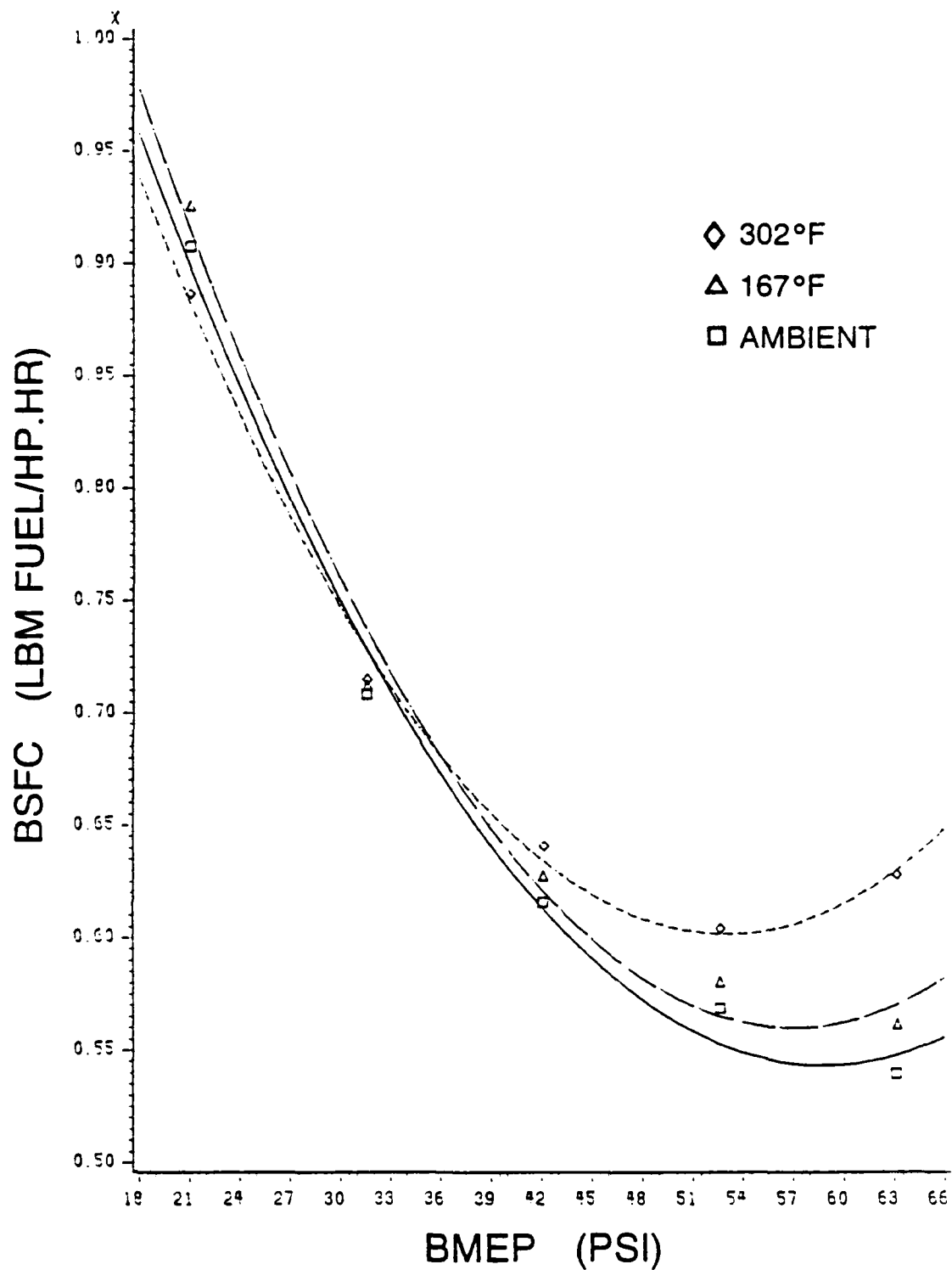

FIGURE 18 EFFECT OF ENGINE LOAD AND INTAKE AIR TEMPERATURE ON THE BSFC FOR NEAT FUEL AT 2000 RPM

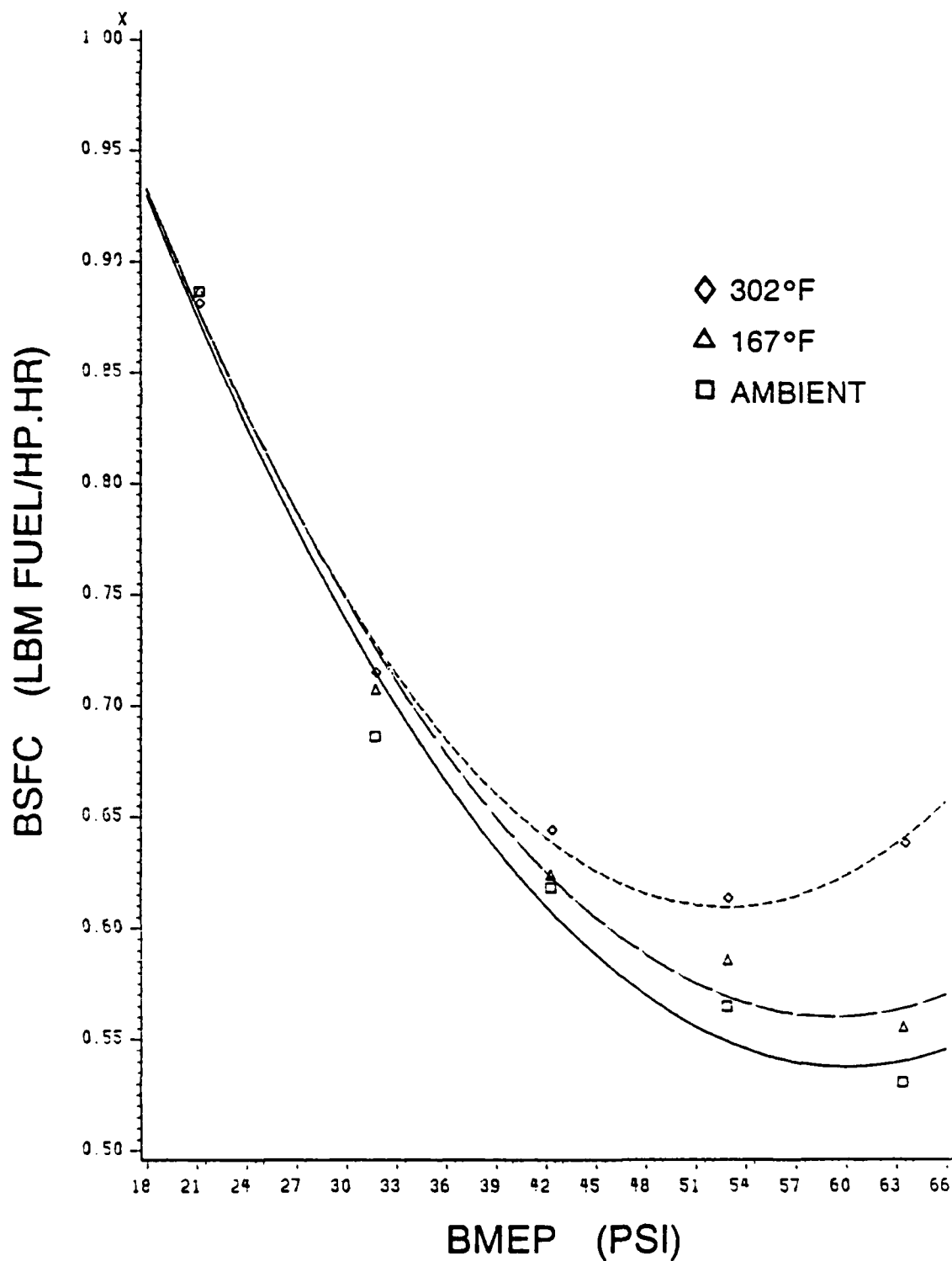

FIGURE 19 EFFECT OF ENGINE LOAD AND INTAKE AIR TEMPERATURE ON THE BSFC FOR 15 % WATER / OIL EMULSION AT 2000 RPM

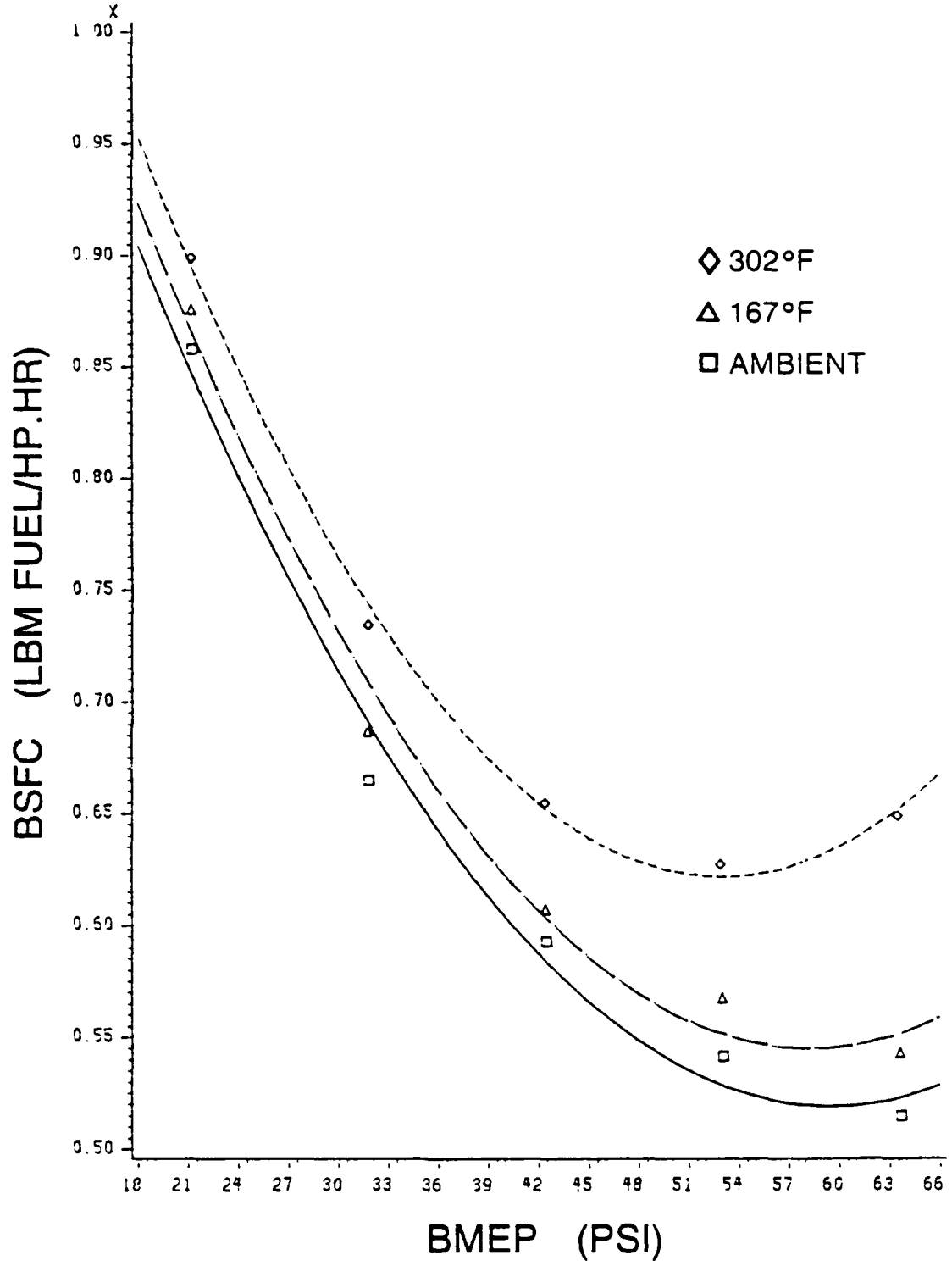

FIGURE 20 EFFECT OF ENGINE LOAD AND INTAKE AIR TEMPERATURE ON THE BSFC FOR 30 % WATER / OIL EMULSION AT 2000 RPM

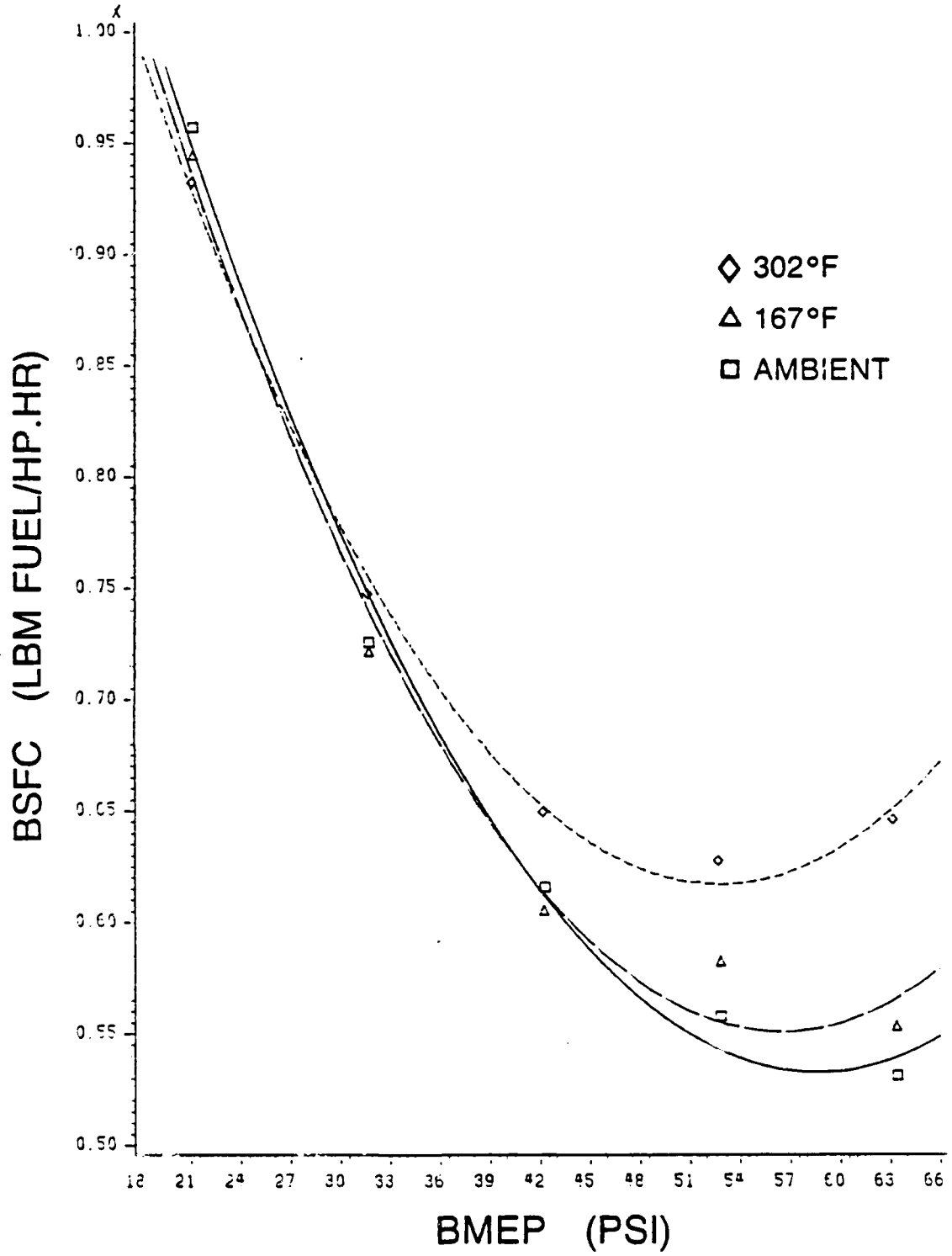

FIGURE 21 EFFECT OF ENGINE LOAD AND INTAKE AIR TEMPERATURE ON THE BSFC FOR 45 % WATER / OIL EMULSION AT 2000 RPM

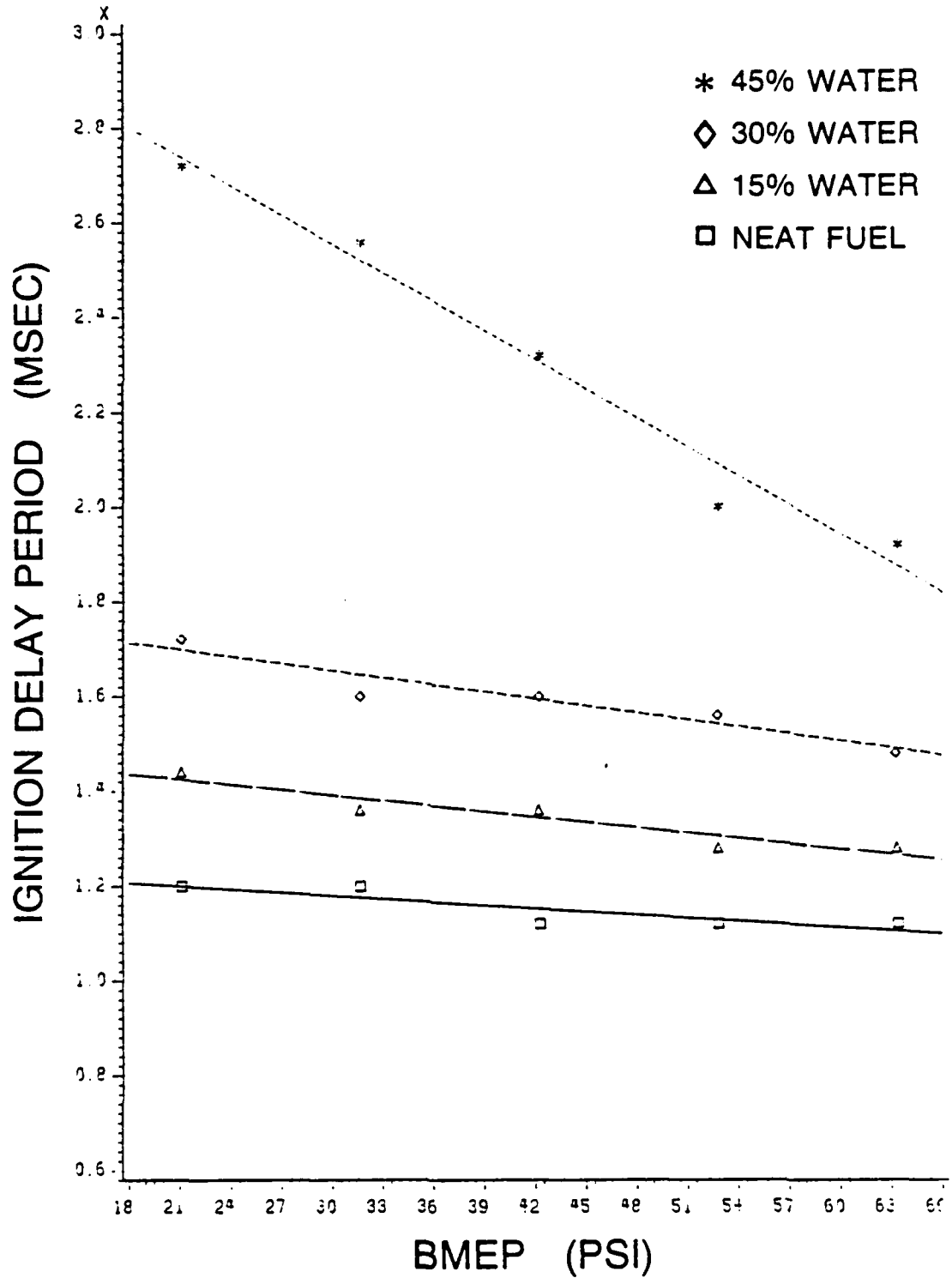

FIGURE 22 EFFECT OF WATER / OIL EMULSIONS ON THE IGNITION DELAY PERIOD FOR AN INTAKE AIR TEMPERATURE OF 167 F AT 1000 RPM

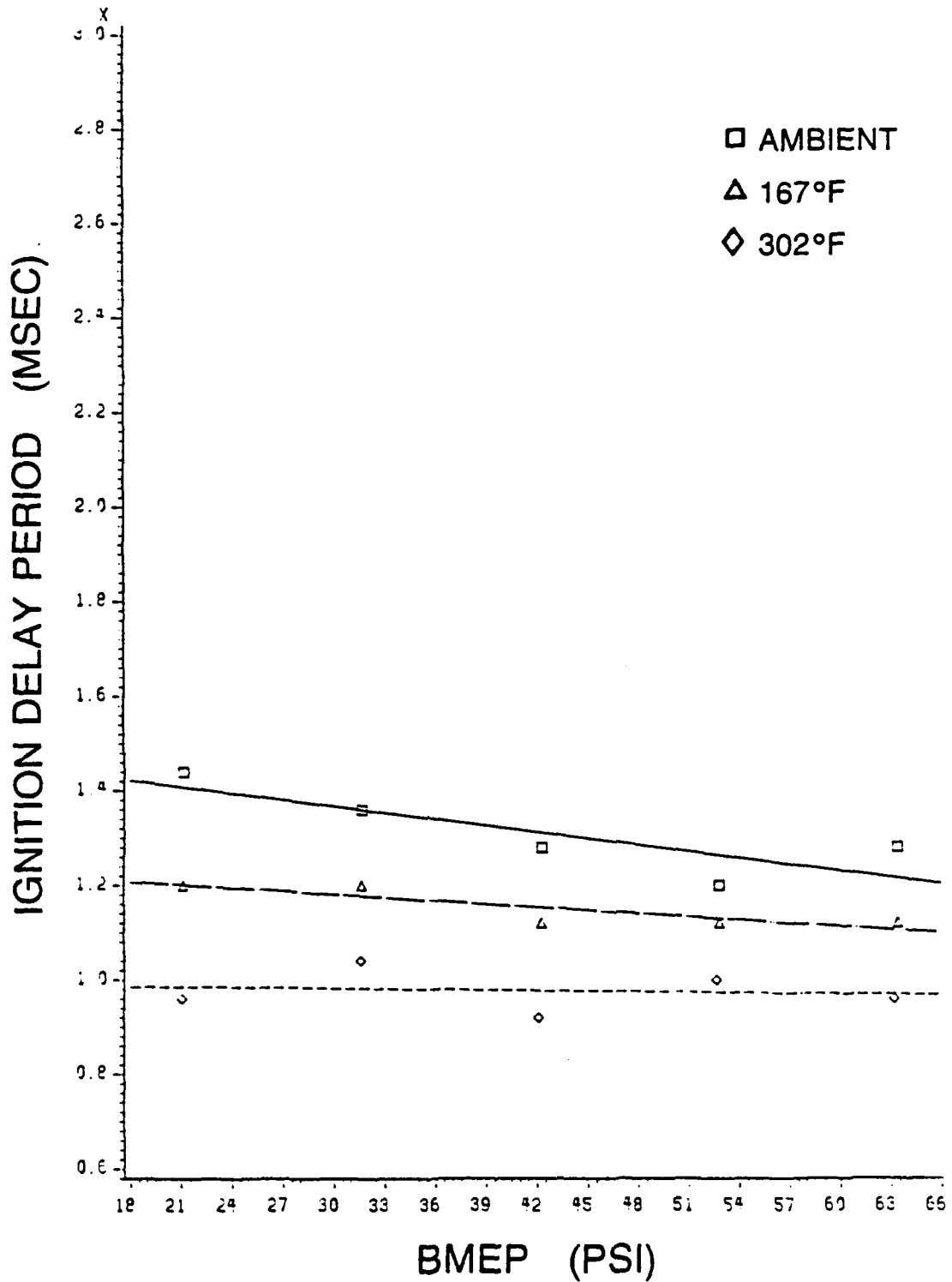

FIGURE 23 EFFECT OF ENGINE LOAD AND INTAKE AIR TEMPERATURE ON THE IGNITION DELAY PERIOD FOR NEAT FUEL AT 1000 RPM

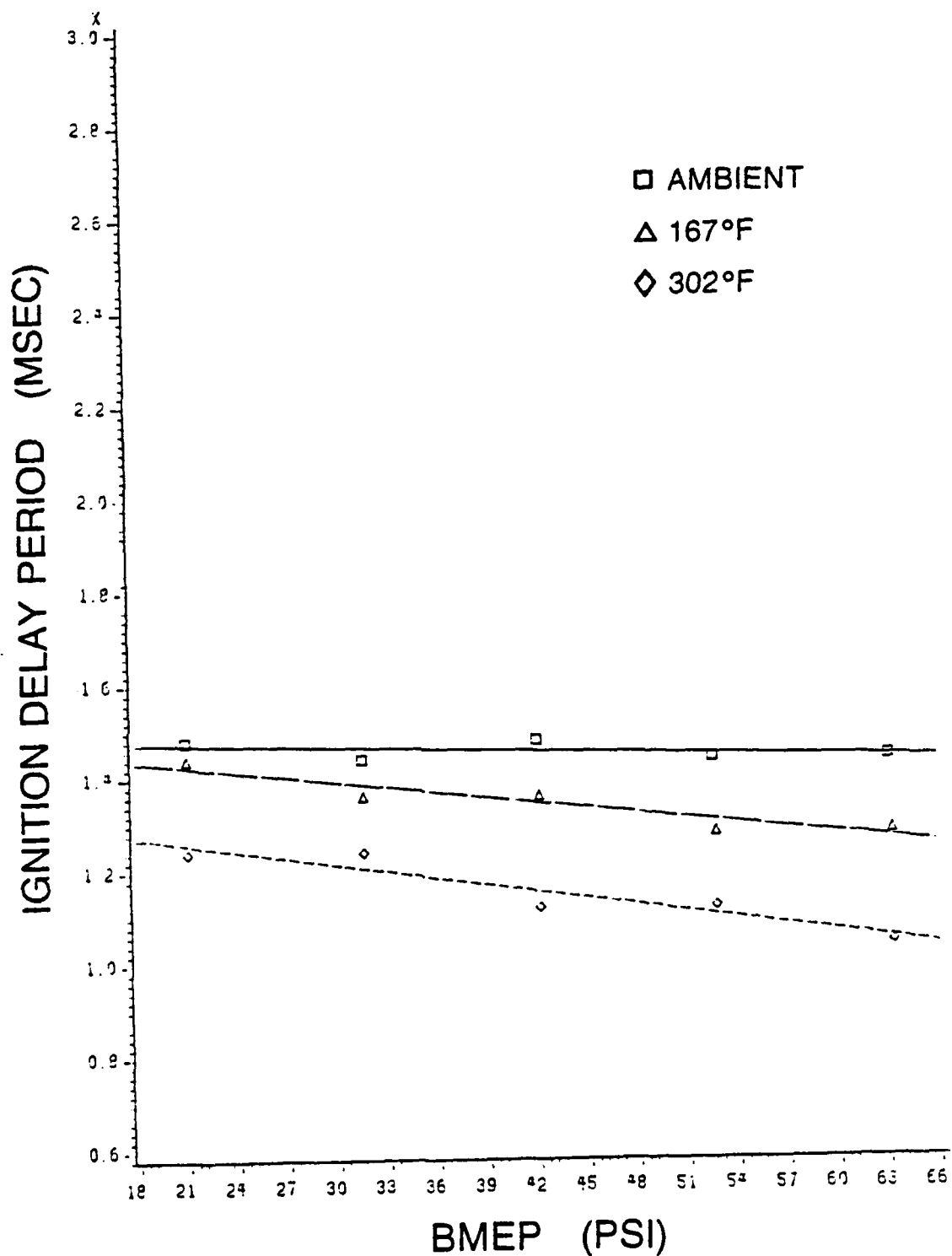

FIGURE 24 EFFECT OF ENGINE LOAD AND INTAKE AIR TEMPERATURE ON THE IGNITION DELAY PERIOD FOR 15 % WATER / OIL EMULSION AT 1000 RPM

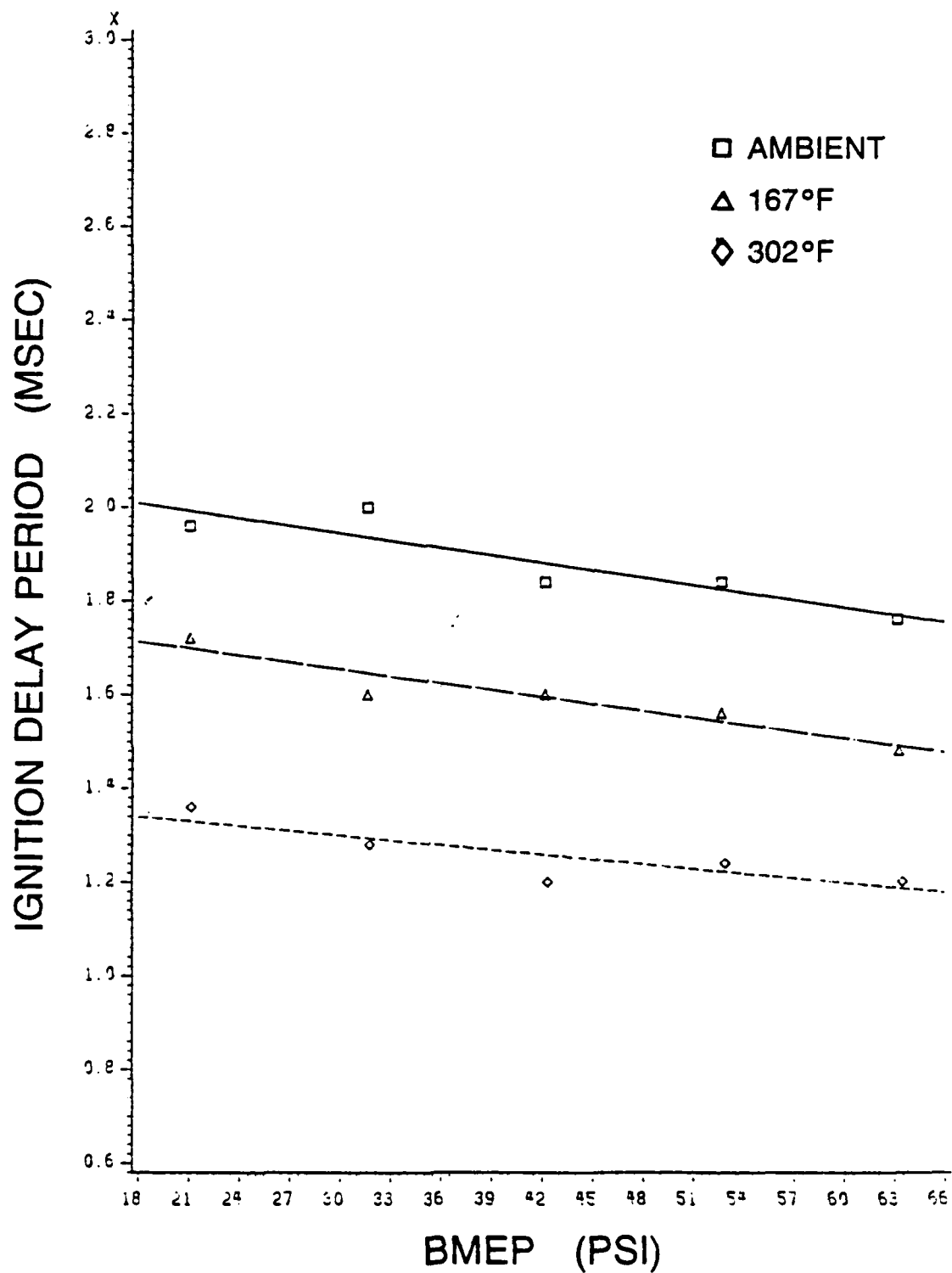

FIGURE 25 EFFECT OF ENGINE LOAD AND INTAKE AIR TEMPERATURE ON THE IGNITION DELAY PERIOD FOR 30 % WATER / OIL EMULSION AT 1000 RPM

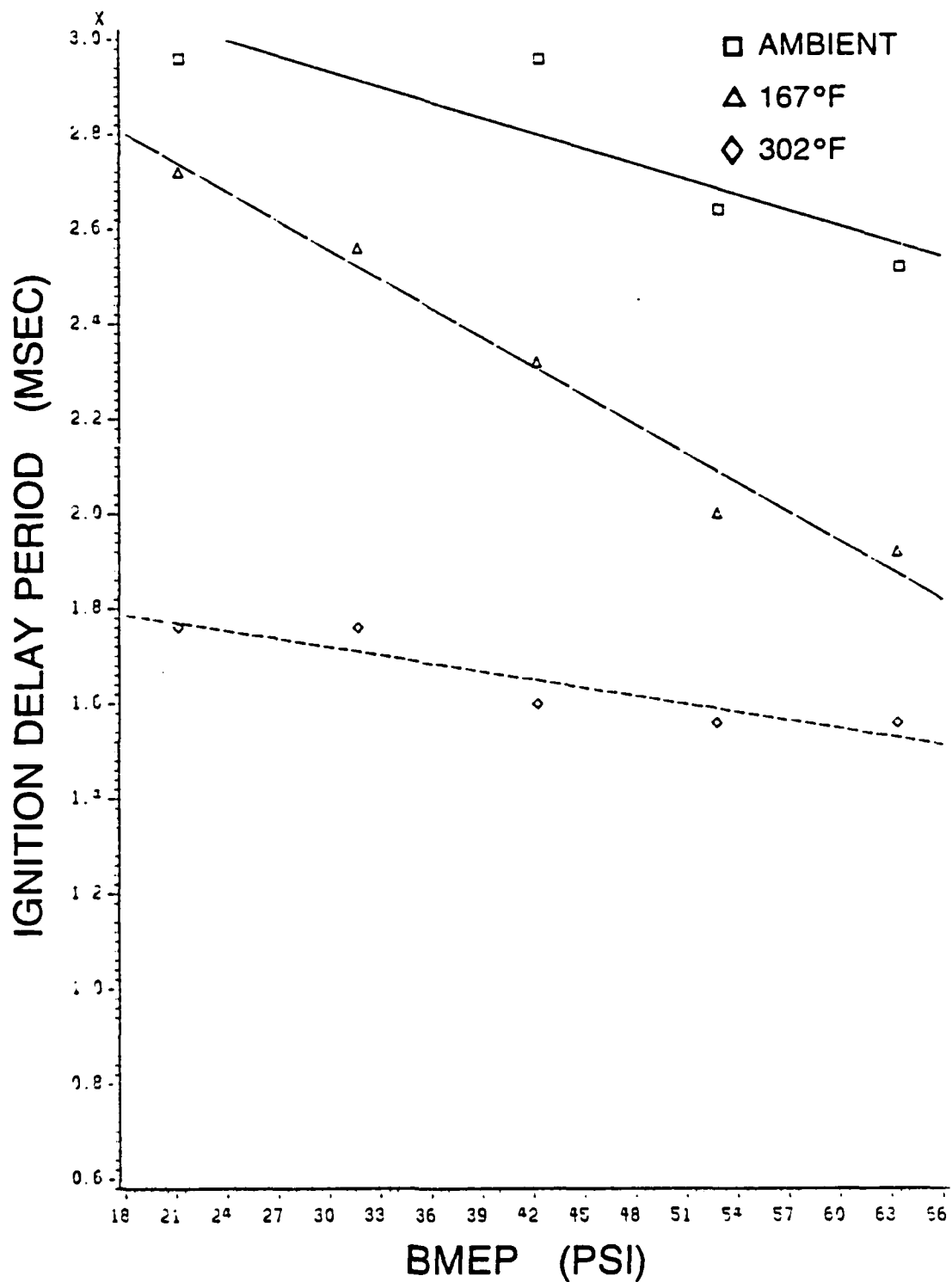

FIGURE 26 EFFECT OF ENGINE LOAD AND INTAKE AIR TEMPERATURE ON THE IGNITION DELAY PERIOD FOR 45 % WATER / OIL EMULSION AT 1000 RPM

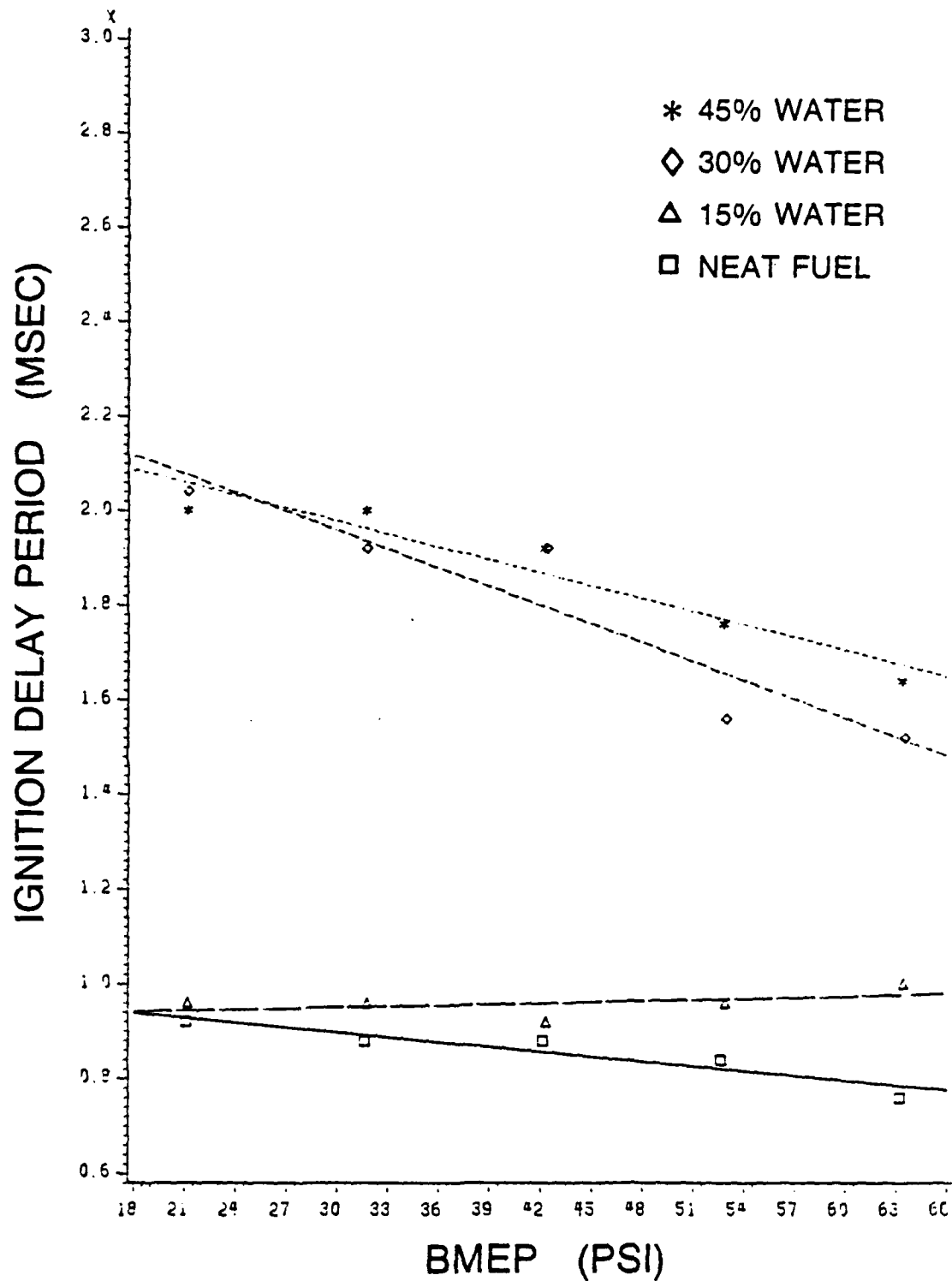

FIGURE 27 EFFECT OF WATER / OIL EMULSIONS ON THE IGNITION DELAY PERIOD FOR AN INTAKE AIR TEMPERATURE OF 167 F AT 2000 RPM

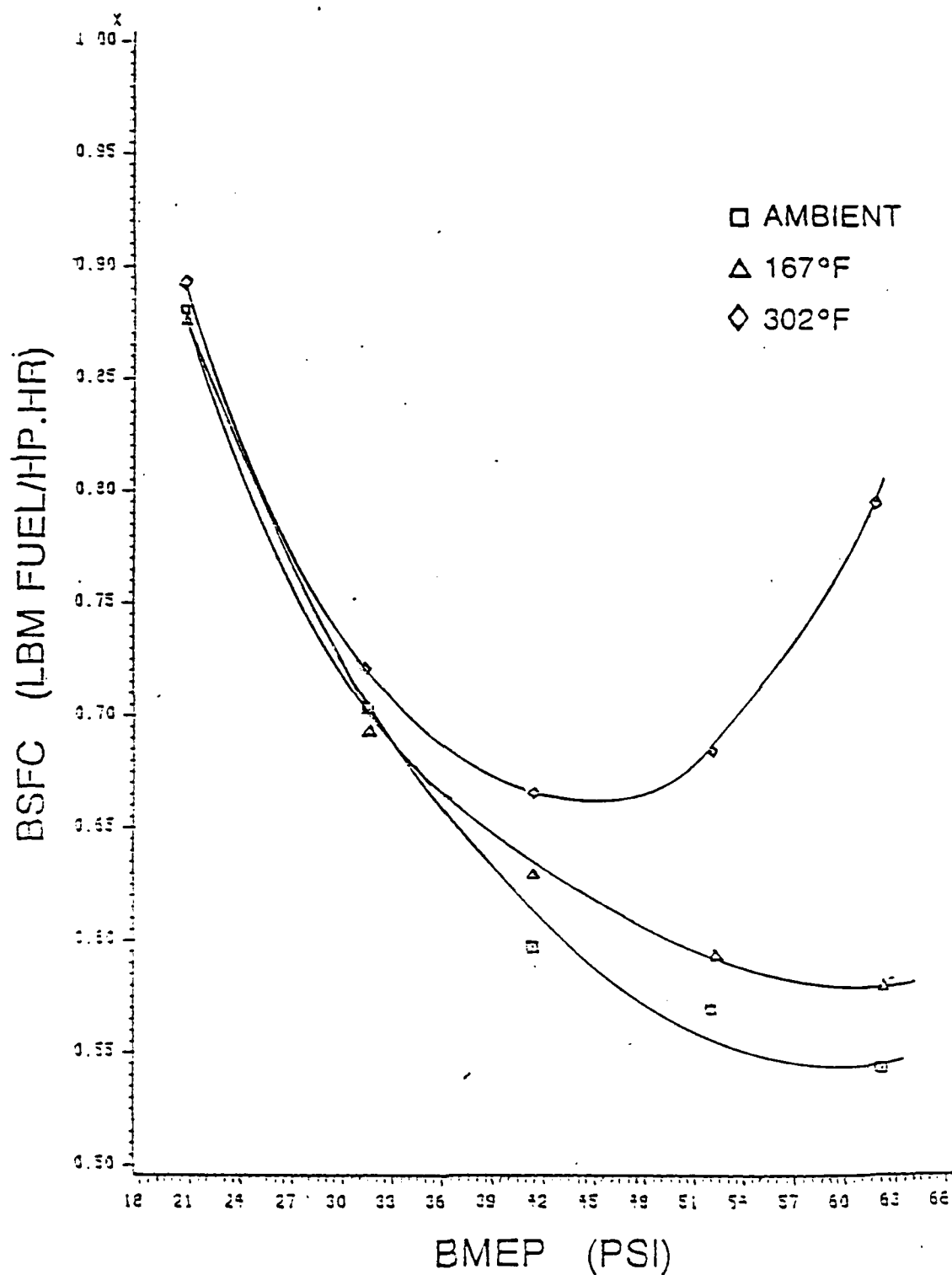

Figure 28 Effect of Engine Load and Intake Air Temperature on the BSFC for Neat JP-4 Fuel at 2000 RPM.

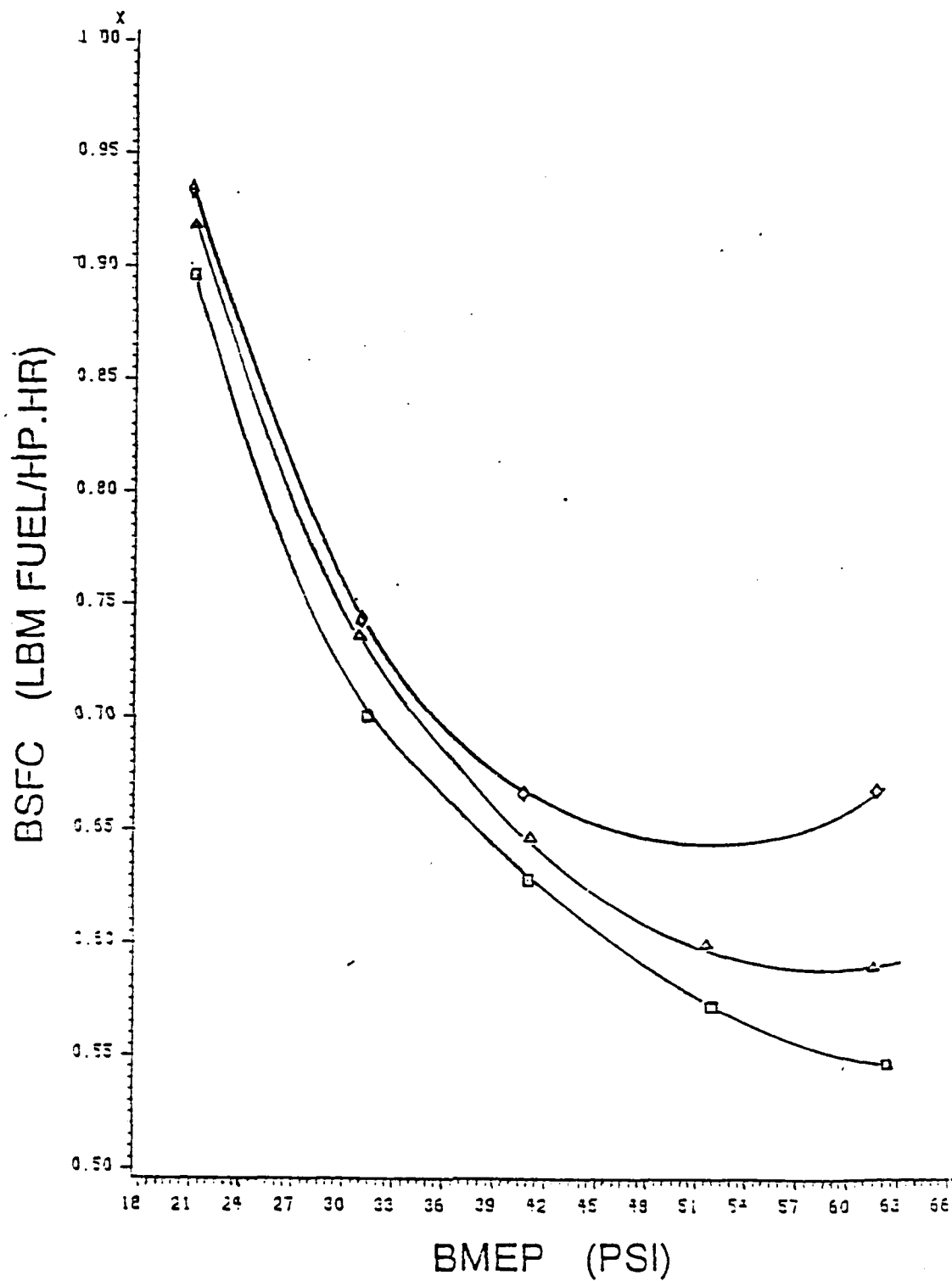

Figure 29 Effect of Engine Load and Intake Air Temperature on the BSFC for 15% w/JP-4 Emulsion at 2000 RPM

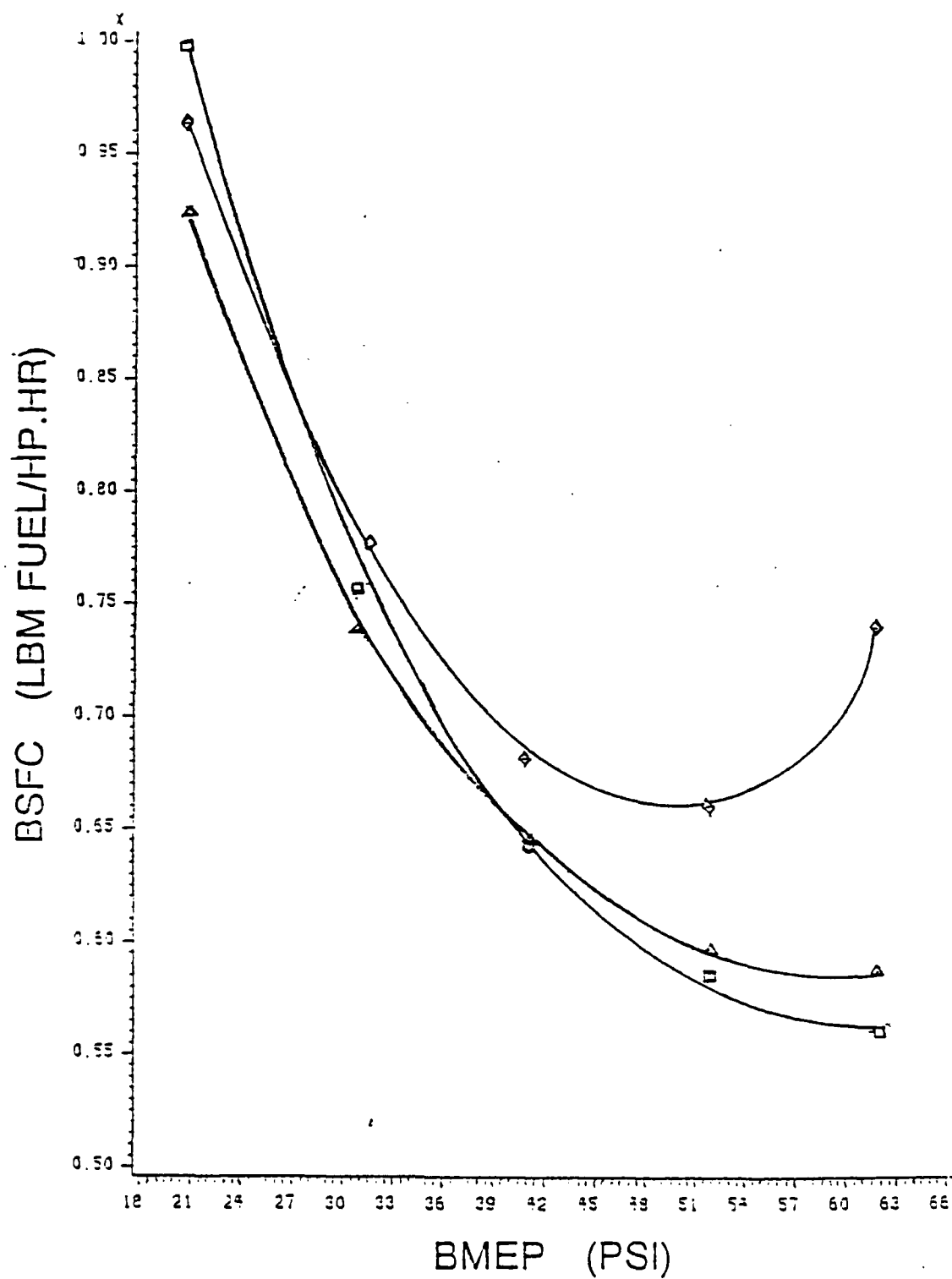

Figure 30 Effect of Engine Load and Intake Air Temperature on the BSFC for 30% w/JP-4 Emulsion at 2000 RPM

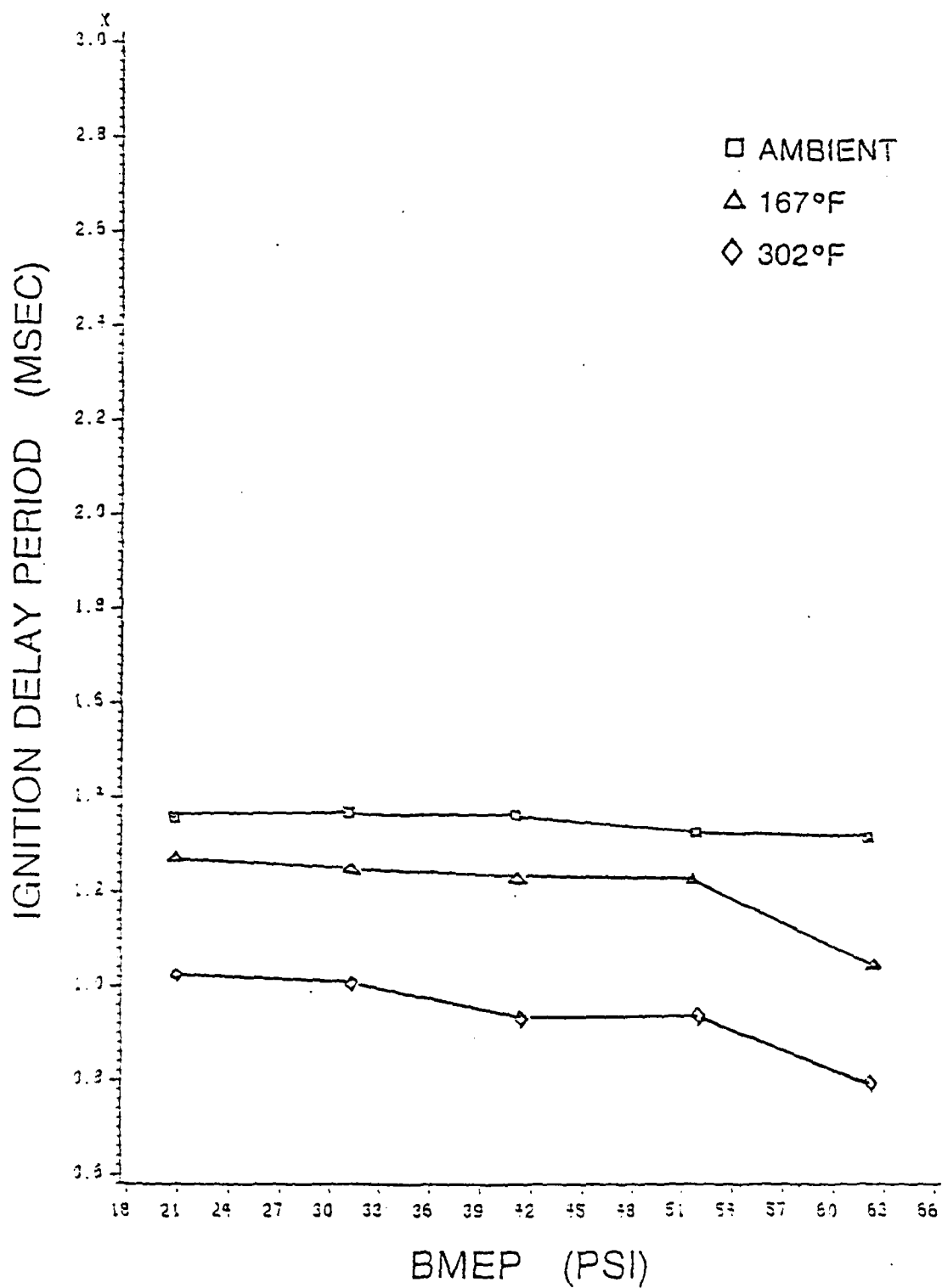

Figure 31 Effect of Engine Load and Intake Air Temperature on the Ignition Delay for Neat JP-4 Fuel at 2000 RPM

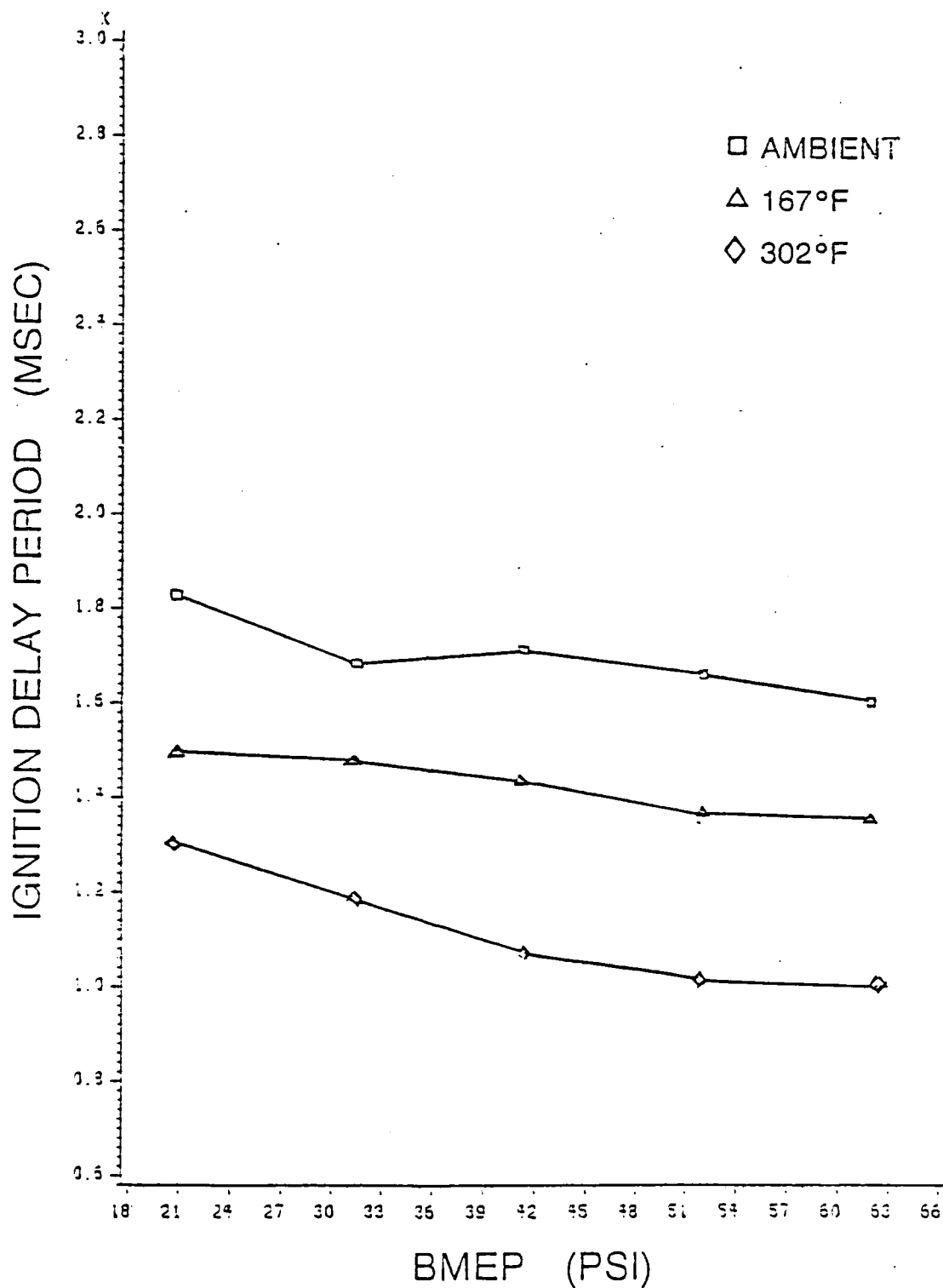

Figure 32 Effect of Engine Load and Intake Air Temperature on the Ignition Delay Period for 15% w/Jp-4 Emulsion at 2000 RPM

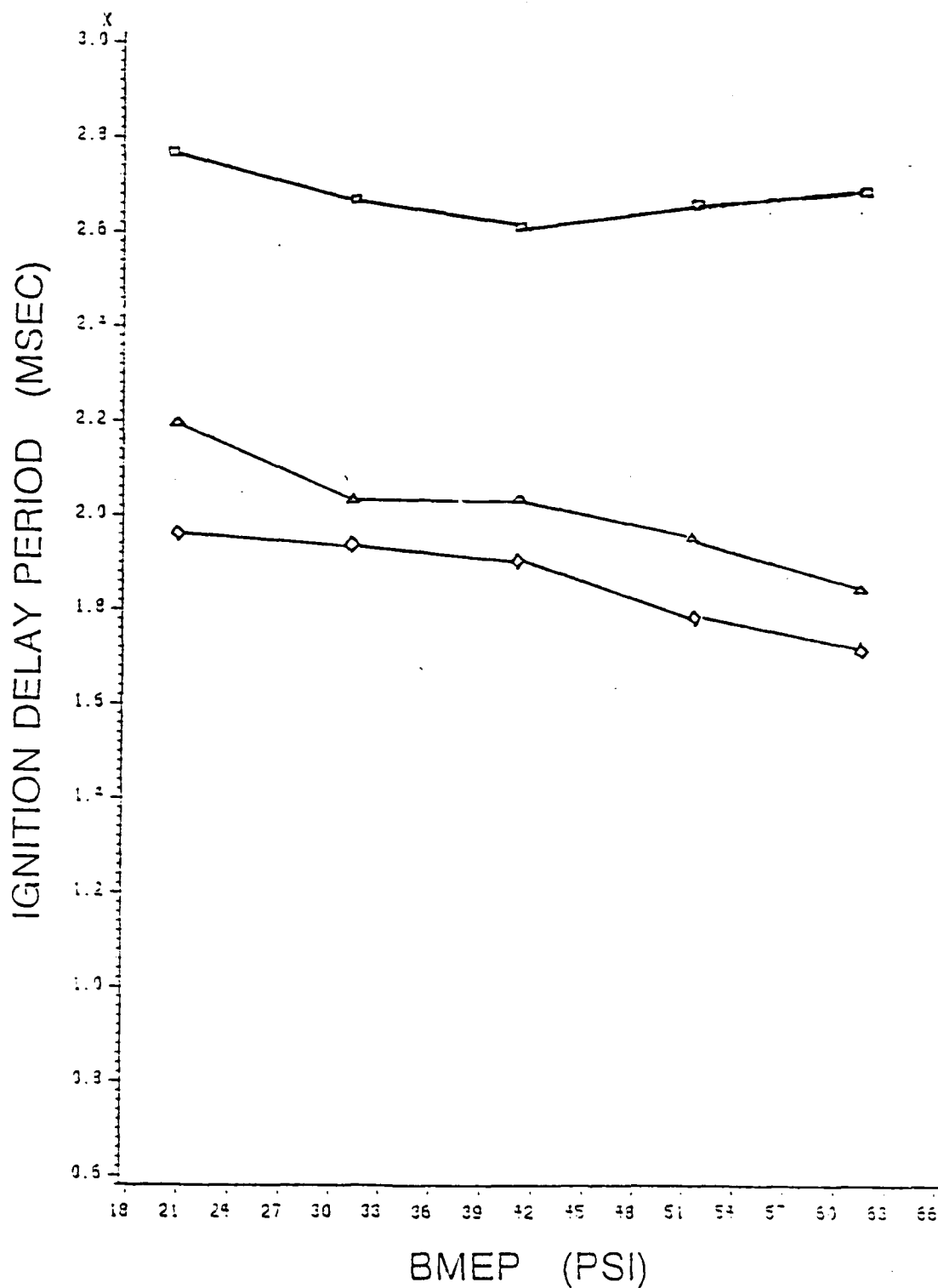

Figure 33 Effect of Engine Load and Intake Air Temperature on the Ignition Delay Period for 30% w/JP-4 Emulsion at 2000 RPM

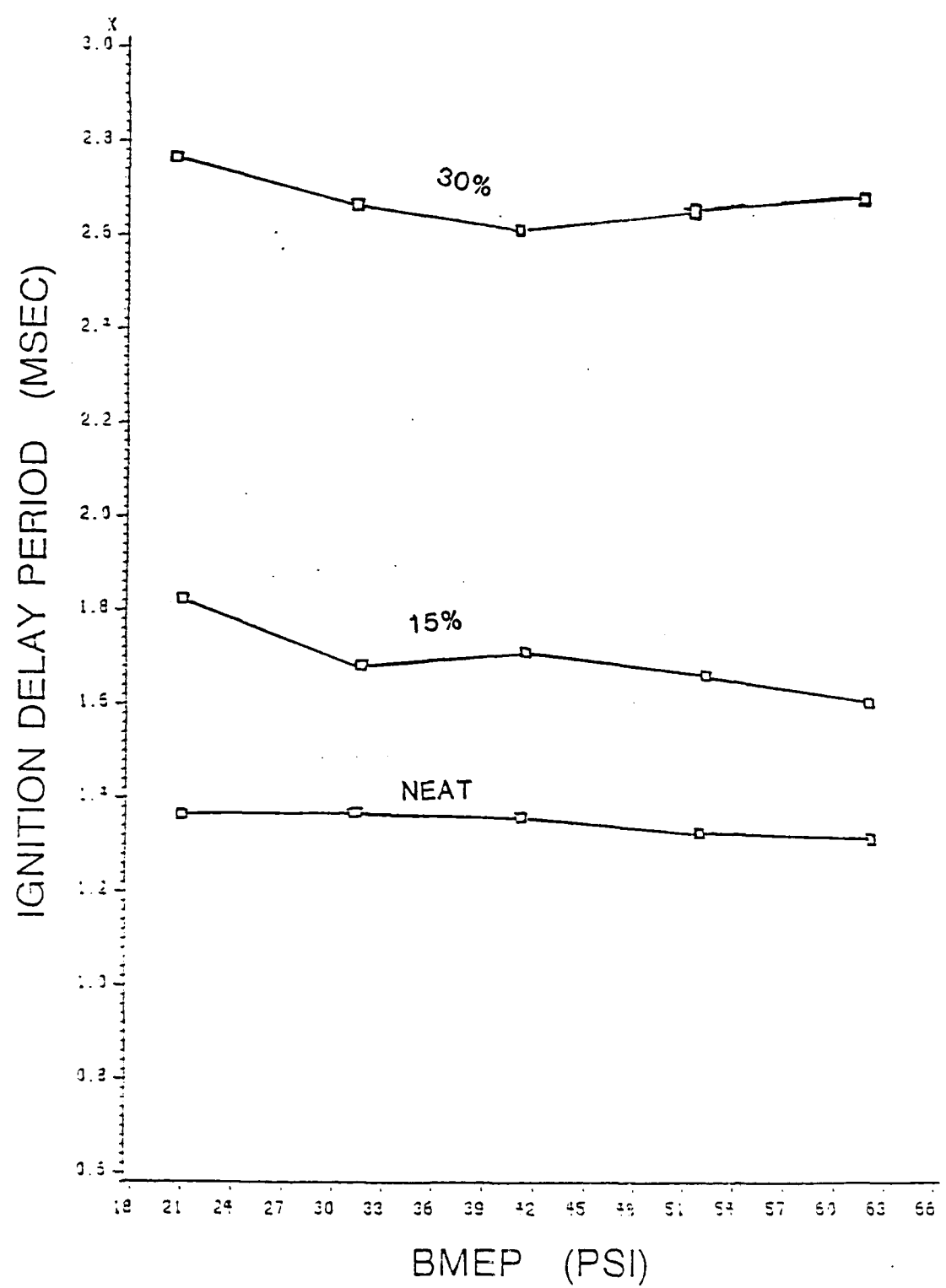

Figure 34 Effect of Water /JP-4 Emulsions on the Ignition Delay Period for Ambient Intake Air Temperature at 2000 RPM

AD-A161 652

PERFORMANCE COMBUSTION CHARACTERISTICS AND EXHAUST
EMISSION OF A DIRECT I (U) NORTH CAROLINA STATE UNIV
AT RALEIGH E M AFIFY 30 SEP 85 ARO-19435 3-EG

2/2

UNCLASSIFIED

DAA229-83-K-0015

F/G 21/7

NL



END

FORM

010

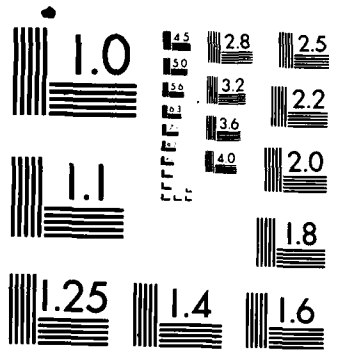

MICROCOPY RESOLUTION TEST CHART
NATIONAL BUREAU OF STANDARDS-1963-A

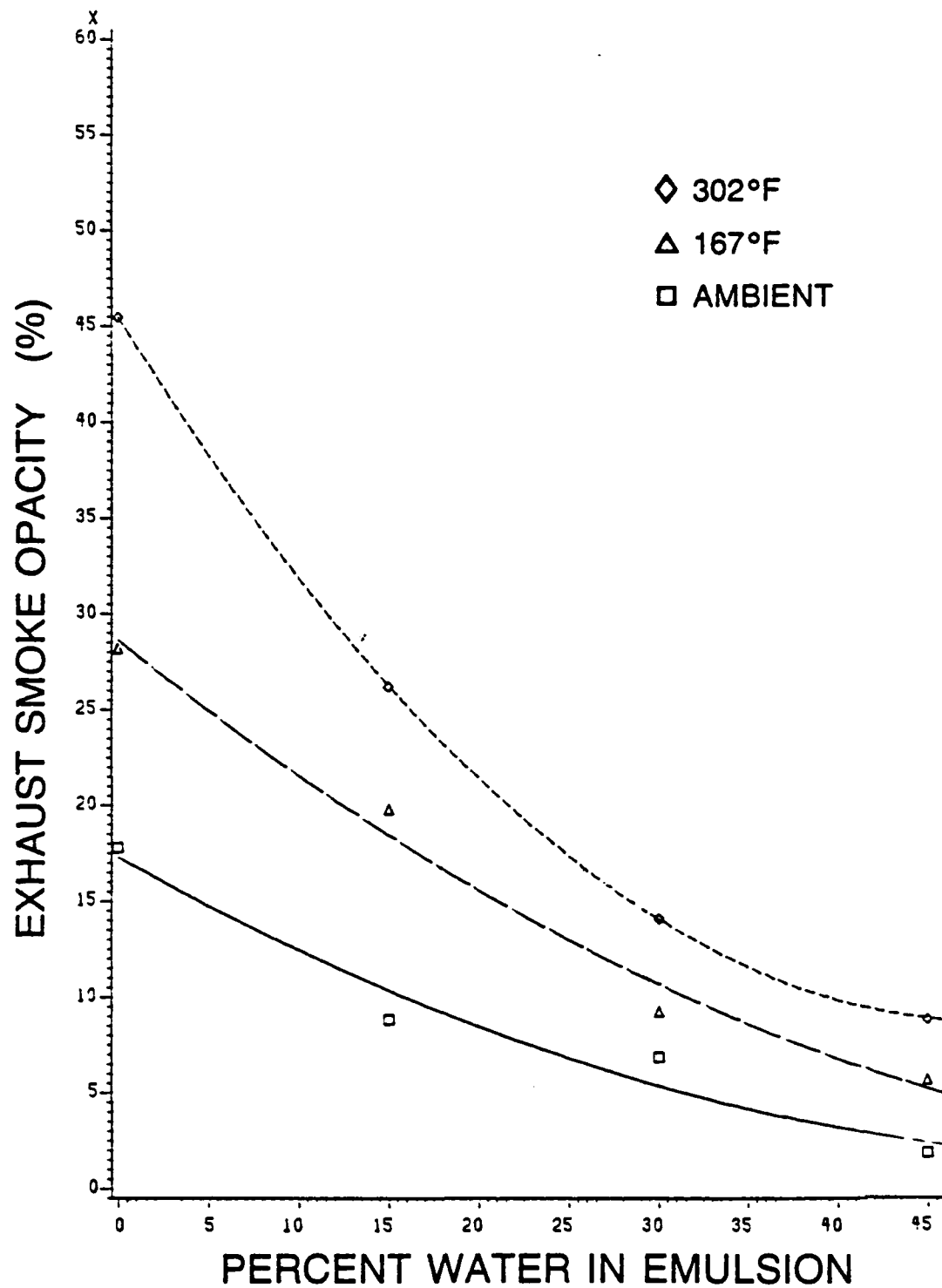

FIGURE 35 EFFECT OF WATER / OIL EMULSIONS AND INTAKE AIR TEMPERATURE ON THE EXHAUST GAS OPACITY FOR BMEP=63 PSI AT 1000 RPM

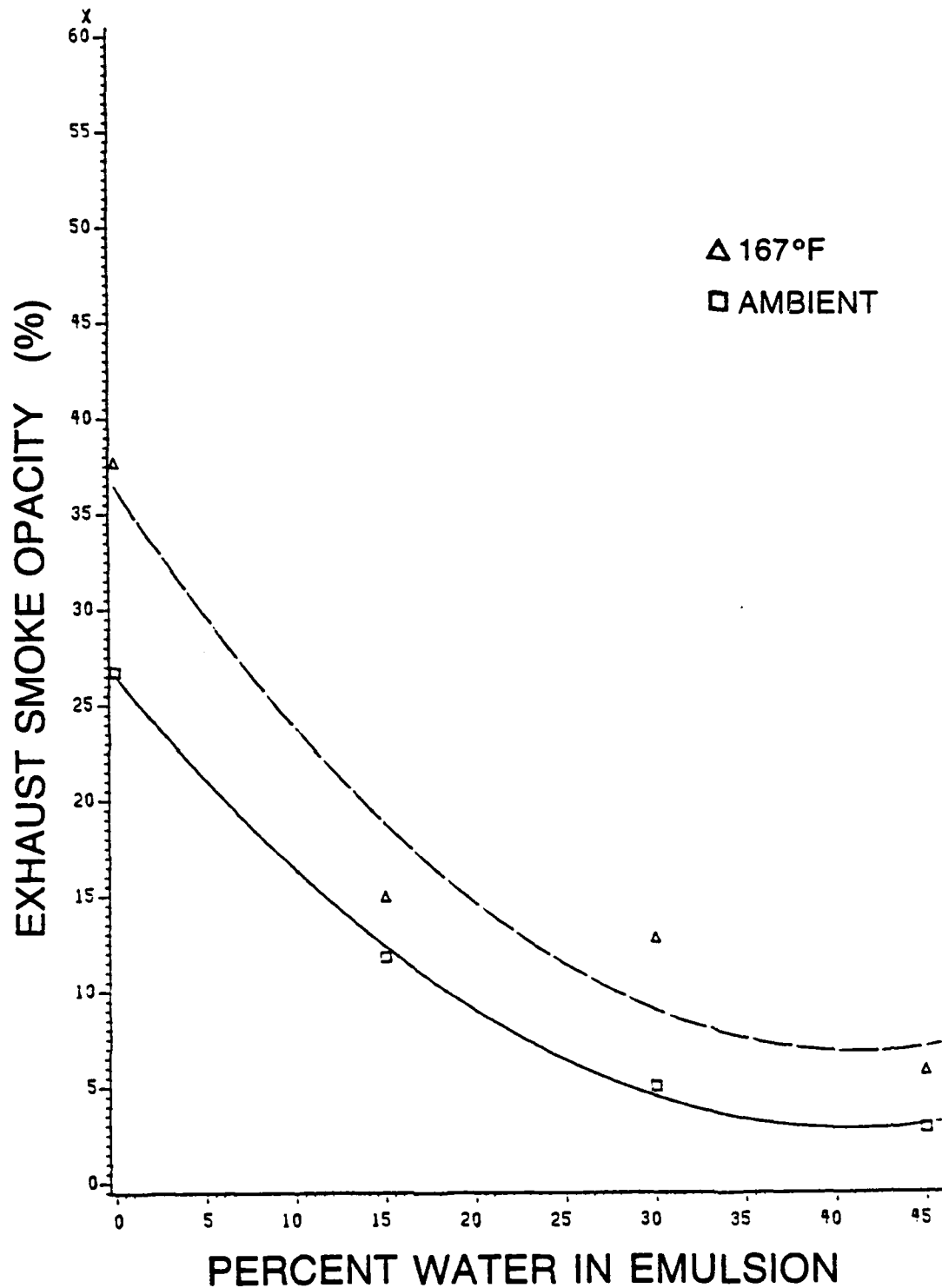

FIGURE 36

EFFECT OF WATER / OIL EMULSIONS AND INTAKE AIR TEMPERATURE ON THE EXHAUST GAS OPACITY FOR BMEP=63 PSI AT 2000 RPM

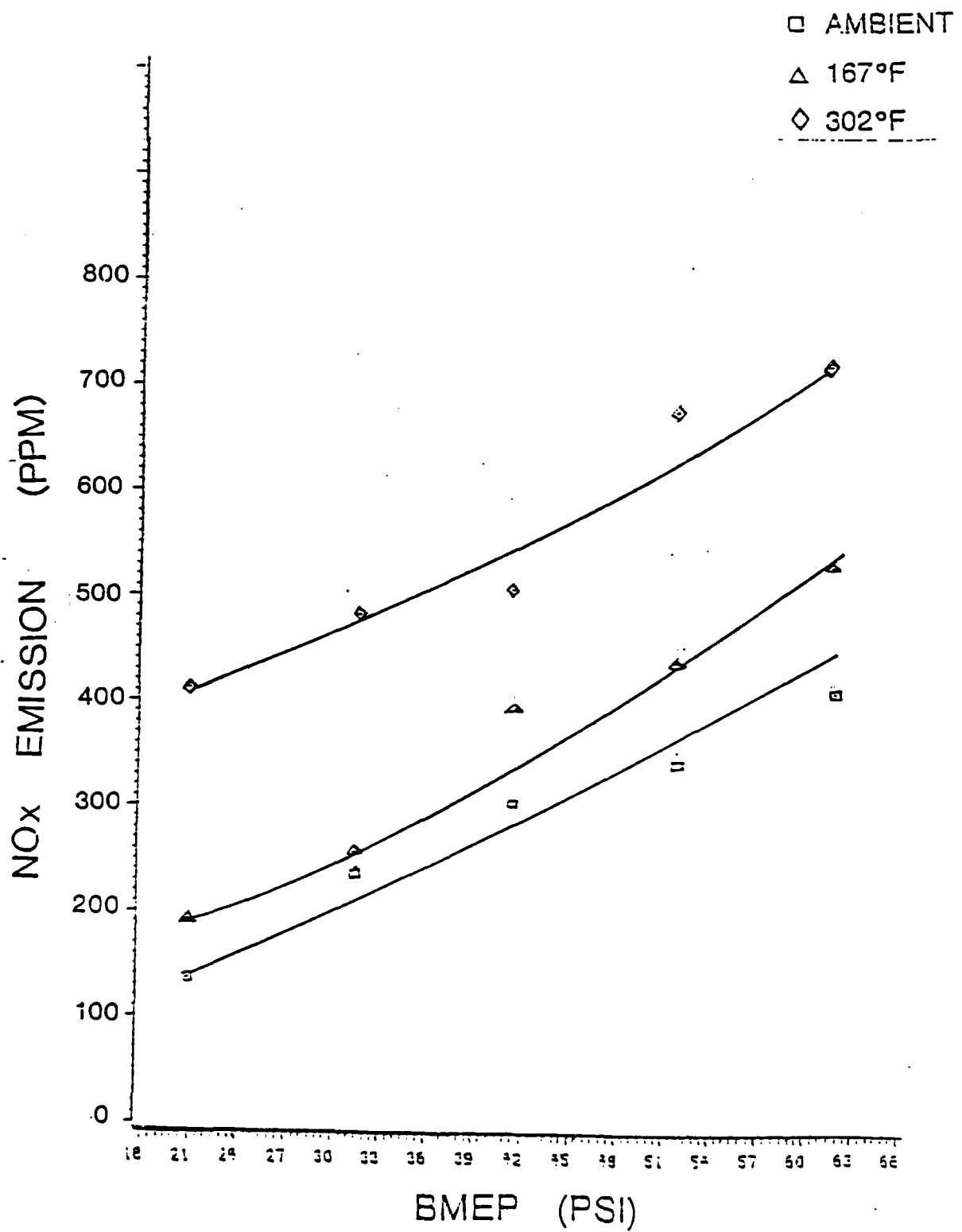

Figure 37 Effect of Engine Load and Intake Air Temperature on Nox Emission for Neat Diesel Fuel #2 at 2000 RPM

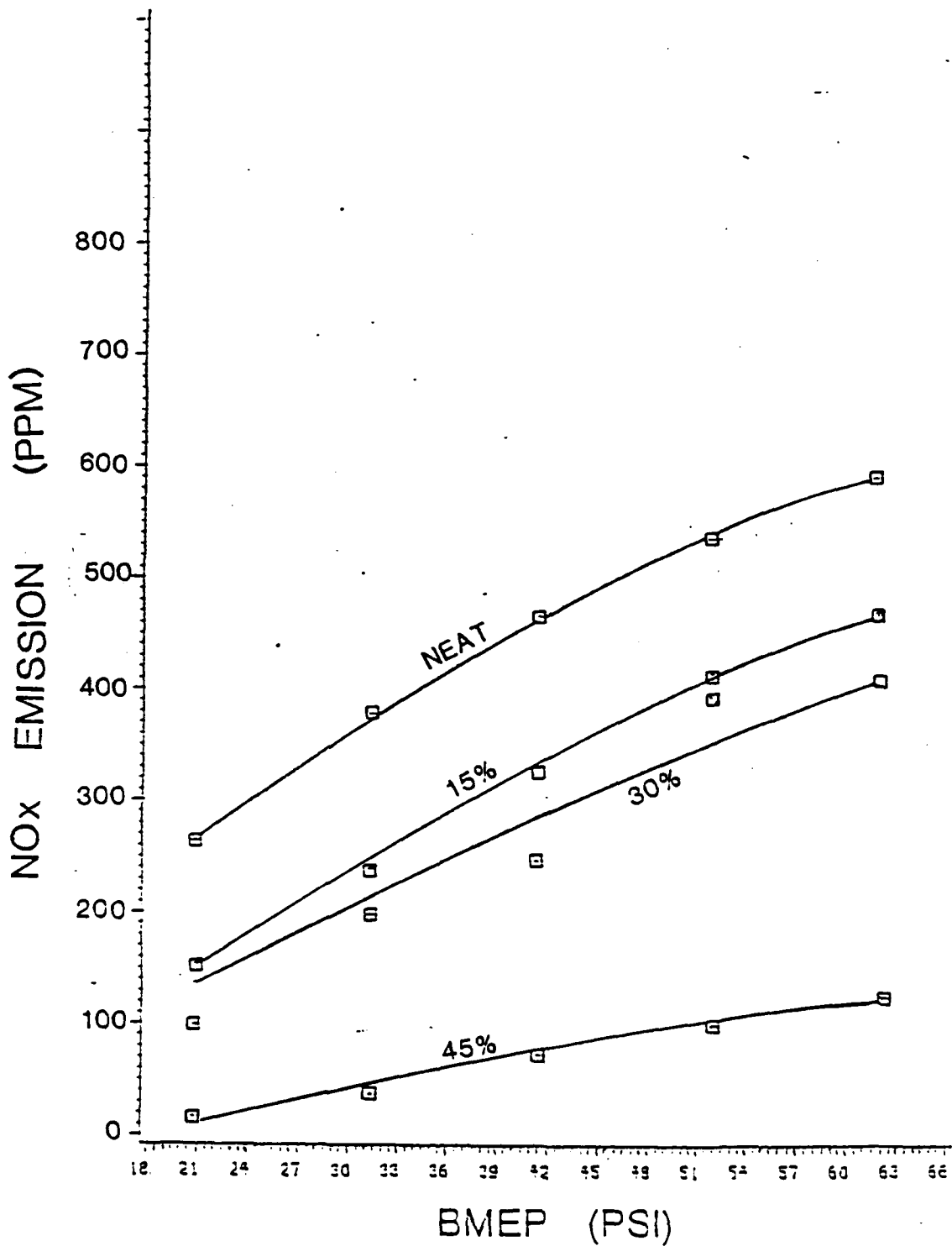

Figure 38 Effect of Engine Load and Water/Diesel Emulsion on Nox Emission at Ambient Intake Air Temperature and 2000 RPM

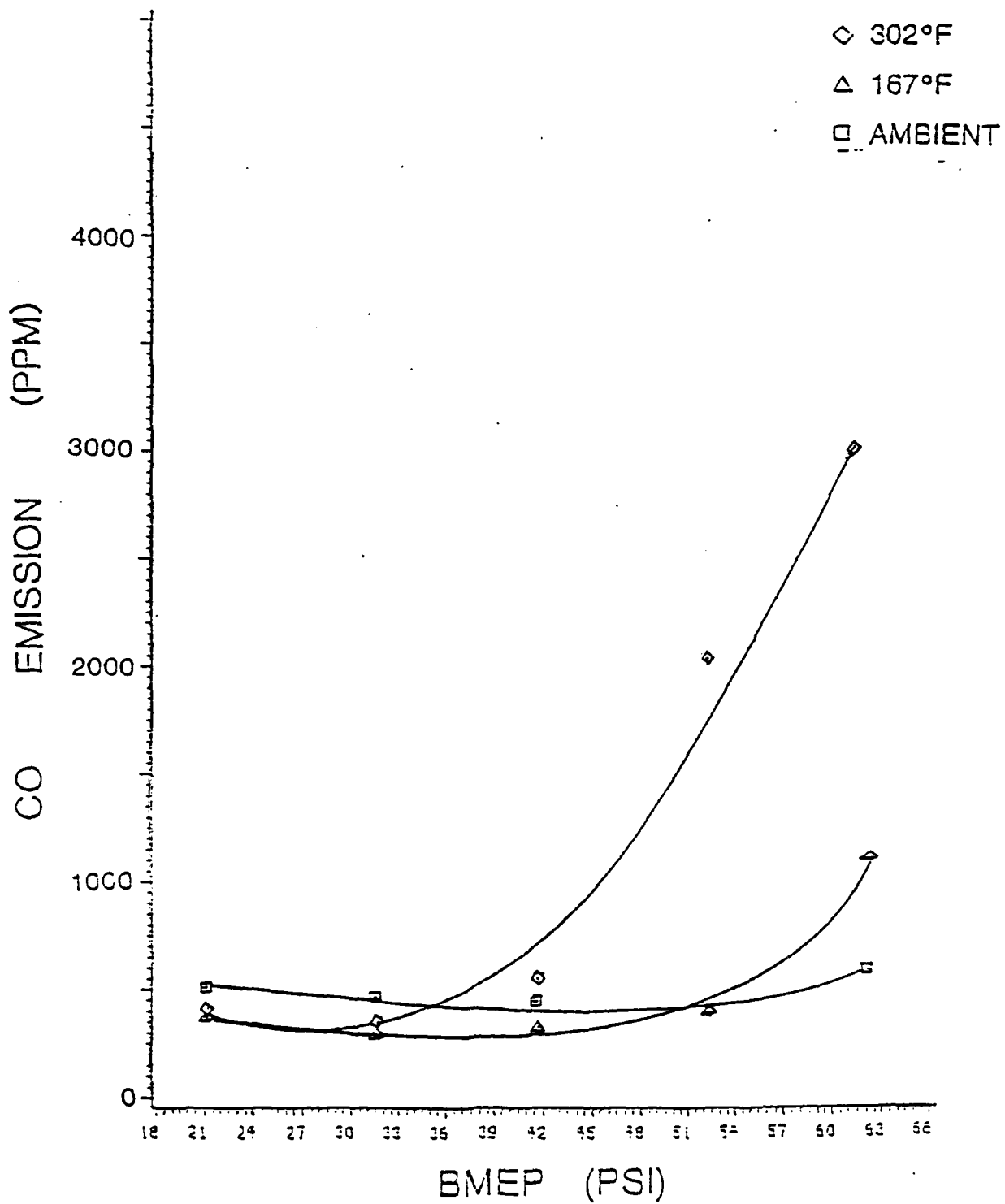

Figure 39 Effect of Engine Load and Intake Air Temperature on Co Emission for Neat Diesel Fuel #2 at 2000 RPM

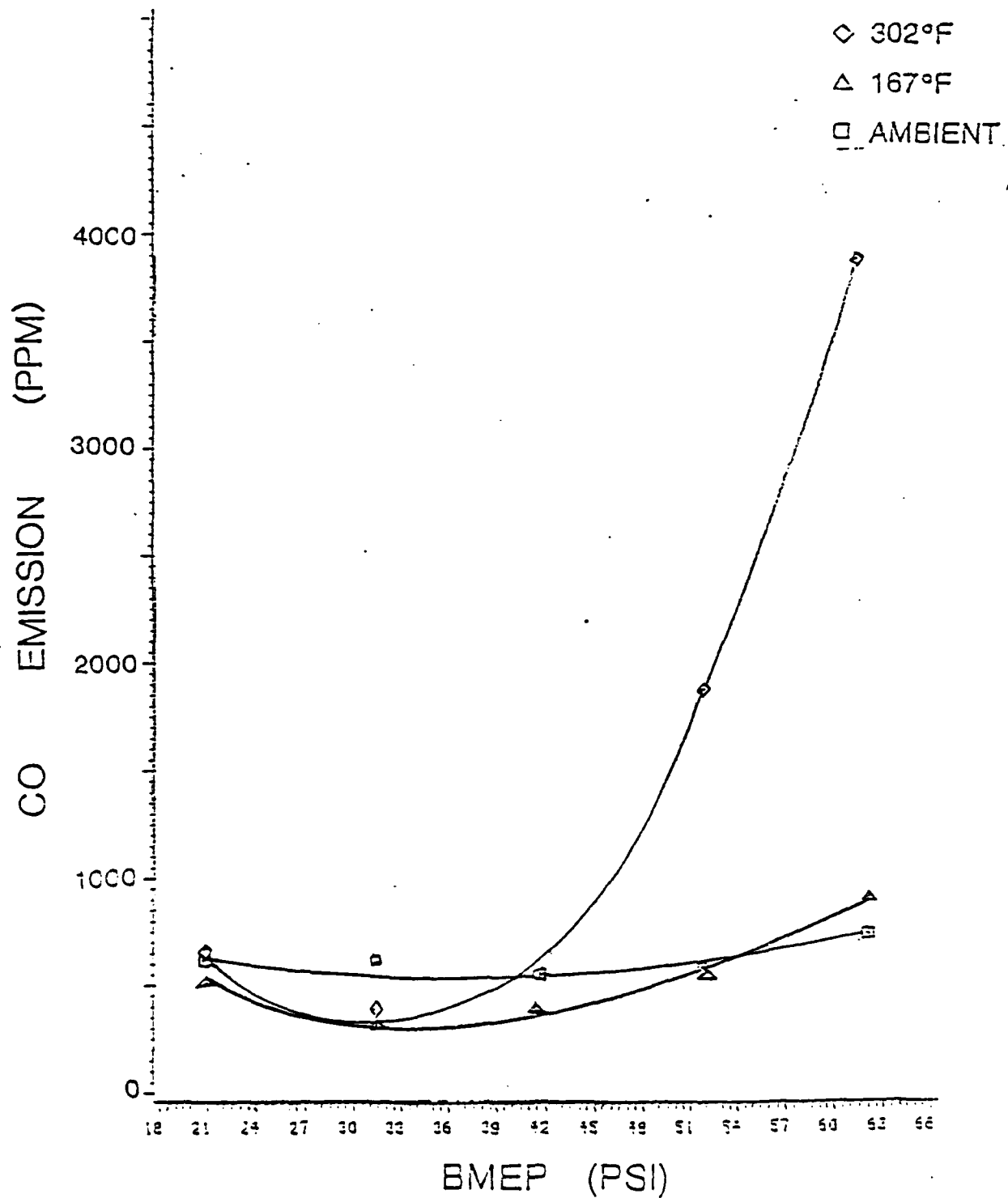

Figure 40 Effect of Engine Load and Air Intake Temperature on Co Emission for w/Diesel Emulsion at 2000 RPM

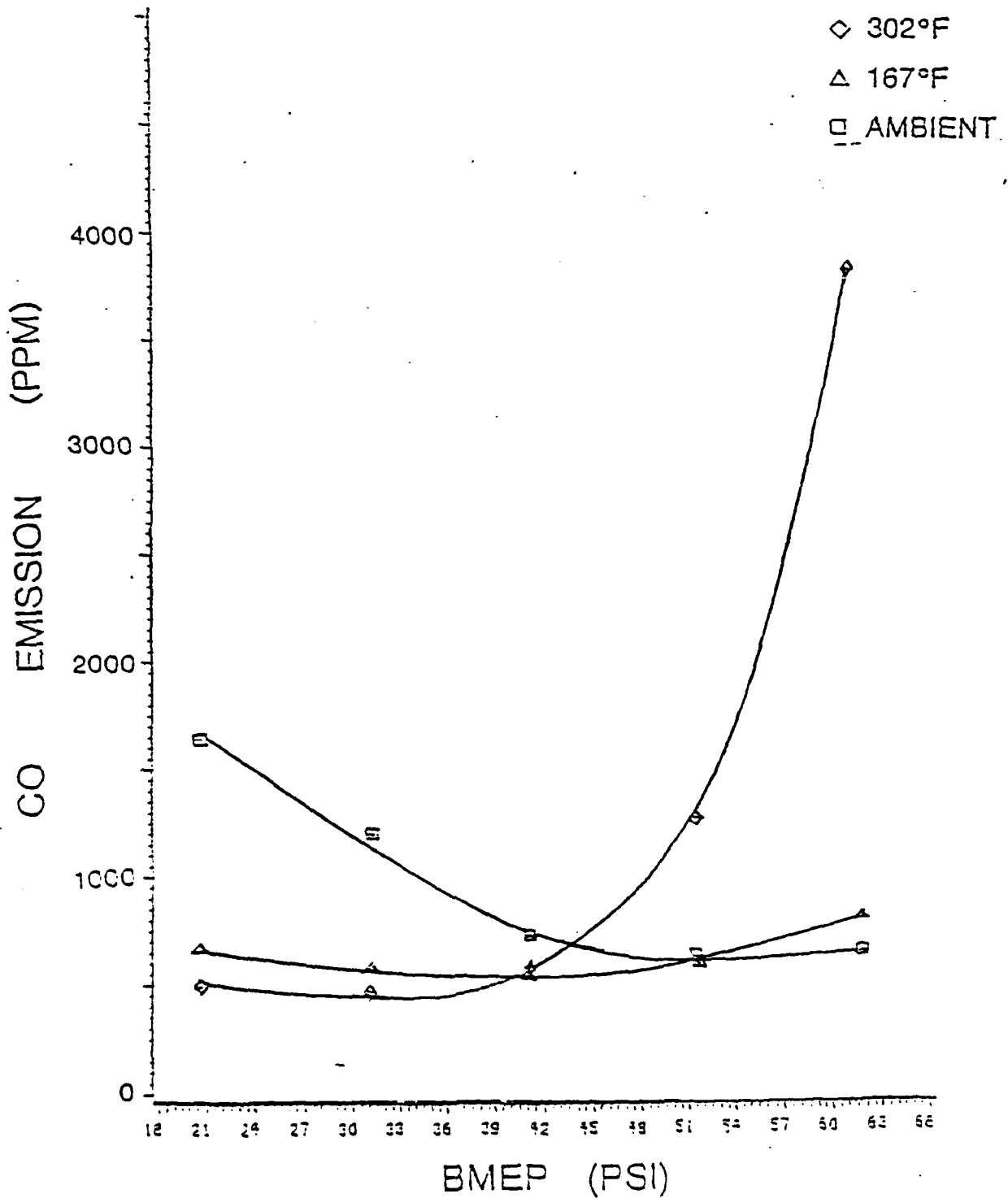

Figure 41 Effect of Engine Load and Air Intake Temperature on Co Emission For 30% w/Diesel Emulsion at 2000 RPM

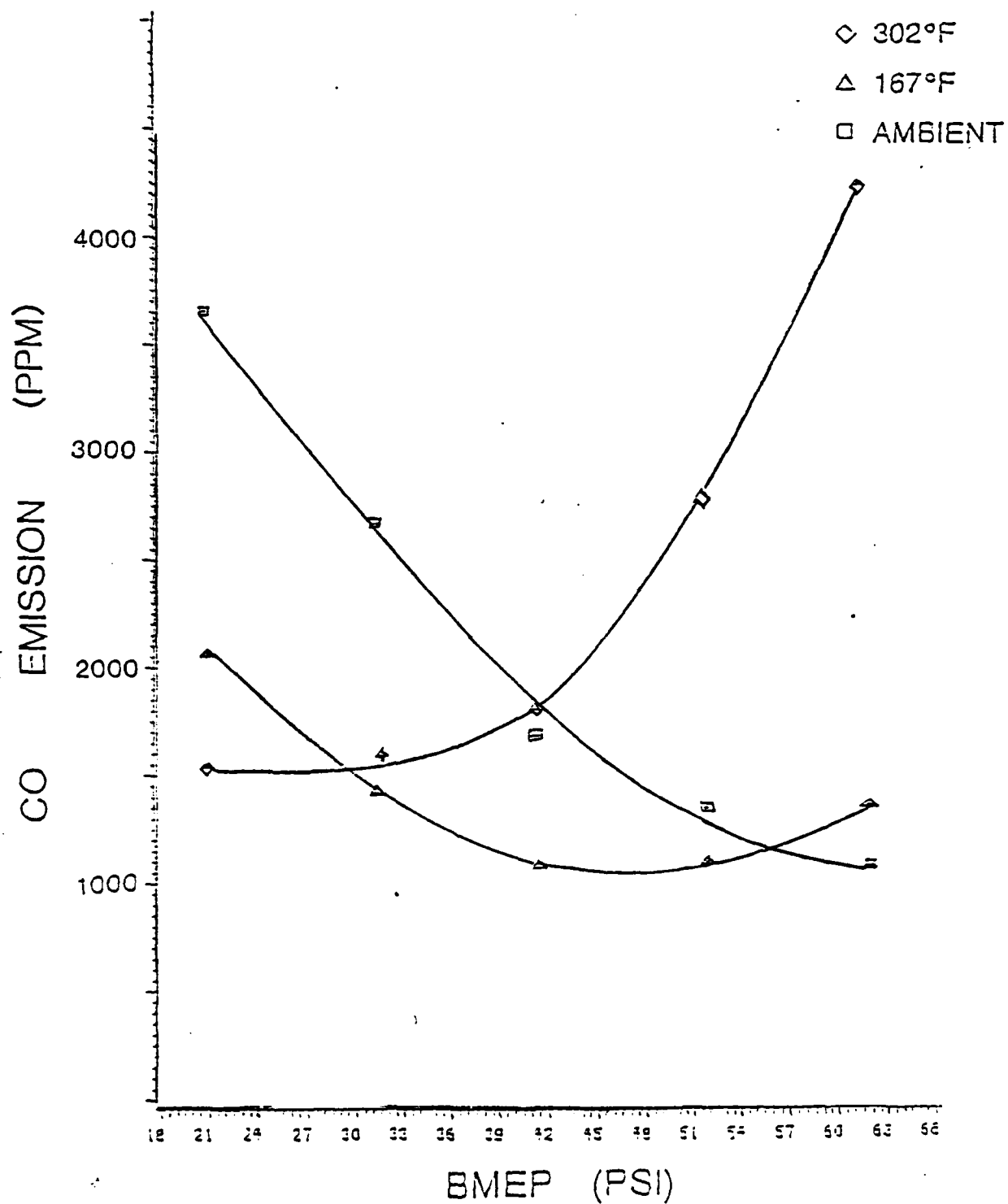

Figure 42 Effect of Engine Load and Intake Air Temperature on Co Emission for 45% w/Diesel Emulsion at 2000 RPM

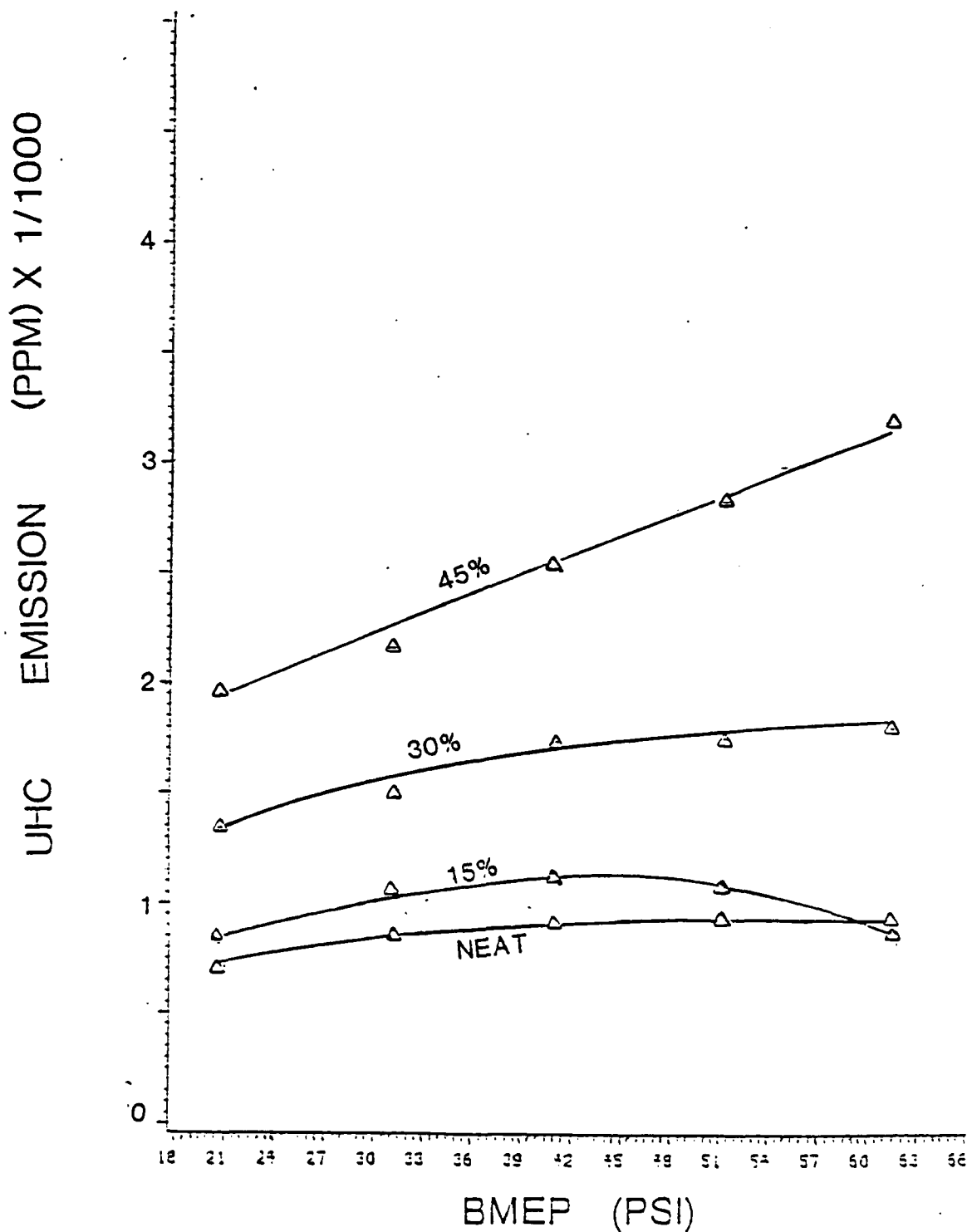

Figure 43 Effect of Engine Load and Water/Diesel Emulsion at 167°F Intake Air Temperature and 2000 RPM

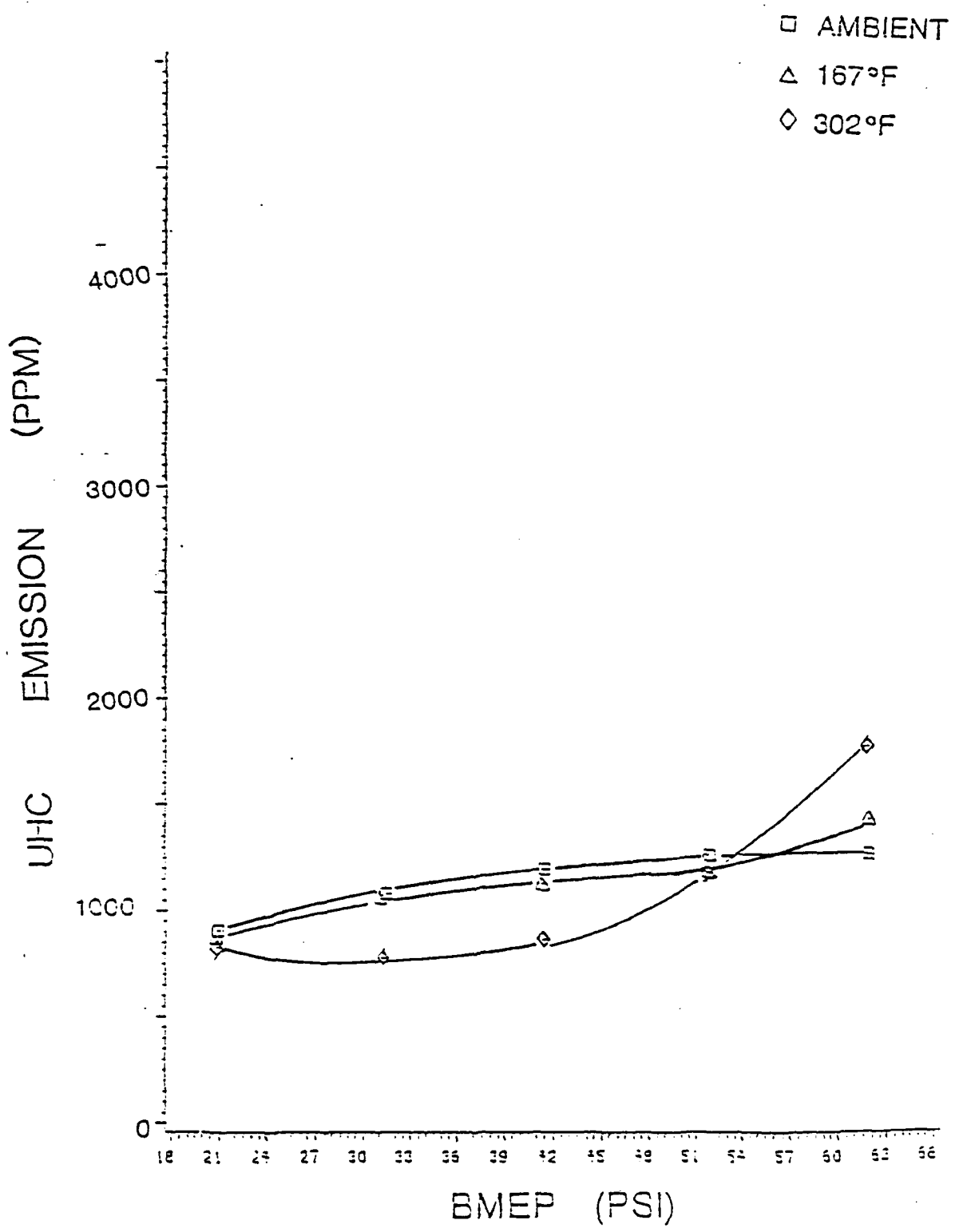

Figure 44 Effect of Engine Load and Intake Air Temperature on UHC Emission for Diesel Fuel #2 at 1000 RPM

END

FILMED

1-86

DTIC