

AD-A161 866

DISTRIBUTION OF CHLORIDE IN A SALT-SATURATED GROUT IN  
CONTACT WITH ROCK S. (U) ARMY ENGINEER WATERWAYS  
EXPERIMENT STATION VICKSBURG MS STRUC.

1/1

UNCLASSIFIED

L D MAKELEY ET AL. SEP 85 MES/HP/SL-85-15

F/G 7/4

NL



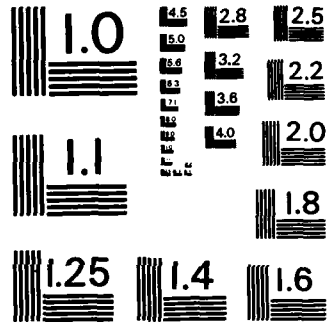

MICROCOPY RESOLUTION TEST CHART  
NATIONAL BUREAU OF STANDARDS-1963-A



US Army Corps  
of Engineers

AD-A161 866

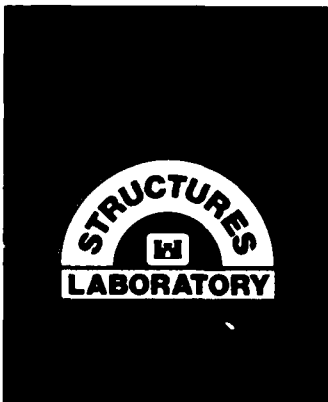
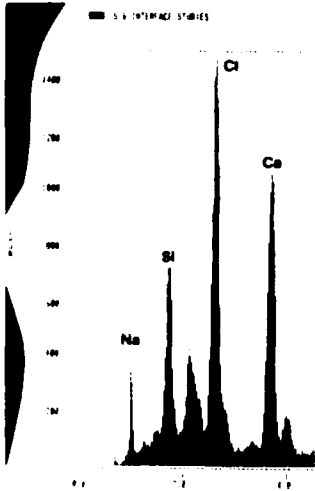

MISCELLANEOUS PAPER SL-85-15

②

# DISTRIBUTION OF CHLORIDE IN A SALT-SATURATED GROUT IN CONTACT WITH ROCK SALT

by

Lillian D. Wakeley, J. Pete Burkes

Structures Laboratory

DEPARTMENT OF THE ARMY  
Waterways Experiment Station, Corps of Engineers  
PO Box 631, Vicksburg, Mississippi 39180-0631

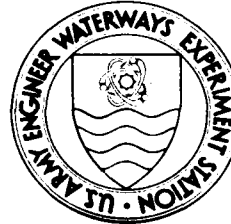

September 1985

Final Report

Approved For Public Release; Distribution Unlimited

DTIC FILE COPY

DTIC  
ELECTE  
DEC 3 1985  
S A D

Prepared for

Sandia National Laboratories  
Albuquerque, New Mexico 87115

85 12 2 15 6

Destroy this report when no longer needed. Do not return  
it to the originator.

The findings in this report are not to be construed as an official  
Department of the Army position unless so designated  
by other authorized documents.

The contents of this report are not to be used for  
advertising, publication, or promotional purposes.  
Citation of trade names does not constitute an  
official endorsement or approval of the use of  
such commercial products.

Unclassified  
SECURITY CLASSIFICATION OF THIS PAGE (When Data Entered)

REPORT DOCUMENTATION PAGE		READ INSTRUCTIONS BEFORE COMPLETING FORM
1. REPORT NUMBER Miscellaneous Paper SL-85-15	2. GOVT ACCESSION NO. <b>AD-A161 866</b>	3. REPORT'S CATALOG NUMBER
4. TITLE (and Subtitle) DISTRIBUTION OF CHLORIDE IN A SALT-SATURATED GROUT IN CONTACT WITH ROCK SALT	5. TYPE OF REPORT & PERIOD COVERED Final report	
7. AUTHOR(s) Lillian D. Wakeley J. Pete Burkes	6. PERFORMING ORG. REPORT NUMBER	
9. PERFORMING ORGANIZATION NAME AND ADDRESS US Army Engineer Waterways Experiment Station Structures Laboratory PO Box 631, Vicksburg, Mississippi 39180-0631	8. CONTRACT OR GRANT NUMBER(s) FAO No. 21-2348	
11. CONTROLLING OFFICE NAME AND ADDRESS Sandia National Laboratories Albuquerque, New Mexico 87115	10. PROGRAM ELEMENT, PROJECT, TASK AREA & WORK UNIT NUMBERS	
14. MONITORING AGENCY NAME & ADDRESS (if different from Controlling Office)	12. REPORT DATE September 1985	13. NUMBER OF PAGES 16
	15. SECURITY CLASS. (of this report) Unclassified	15a. DECLASSIFICATION DOWNGRADING SCHEDULE
16. DISTRIBUTION STATEMENT (of this Report) Approved for public release; distribution unlimited.		
17. DISTRIBUTION STATEMENT (of the abstract entered in Block 20, if different from Report)		
18. SUPPLEMENTARY NOTES Available from National Technical Information Service, 5285 Port Royal Road, Springfield, Virginia 22161.		
19. KEY WORDS (Continue on reverse side if necessary and identify by block number) Grouting Halite Salt grout		
20. ABSTRACT (Continue on reverse side if necessary and identify by block number) Bond strength of a sodium chloride-saturated grout to rock salt suggested chemical bonding existed across the interface. Chemical analyses using scanning electron microscopy/energy-dispersive X-ray spectroscopy of various locations in the grout showed a significantly greater quantity of chloride near the interface than near the perimeter of specimens. The resultant concentration of chloride is at least partially controlled by the proximity of rock salt.		

PREFACE

This report was prepared for Sandia National Laboratories under FAO No. 21-2348, as an FY 85 milestone for that contract. L. D. Tyler was Sandia project manager.

The work reported herein was accomplished in the Concrete Technology Division (CTD) of the Structures Laboratory (SL), US Army Engineer Waterways Experiment Station (WES), under the direction of Mr. J. M. Scanlon, Chief, CTD, and Mr. B. Mather, Chief, SL. Dr. L. D. Wakeley prepared this report, with the assistance of Messrs. J. P. Burkes, E. F. O'Neil III, and T. S. Poole, and Ms. C. Mayfield. Mr. A. D. Buck was project leader.

Commander and Director of WES during the conduct of this study and the preparation of this report was COL Robert C. Lee, CE; Mr. Fred R. Brown was Technical Director. During the publication of this report, COL Allen F. Grum, USA, was Director of WES; Dr. Robert W. Whalin was Technical Director.

Distribution	
General	<input checked="" type="checkbox"/>
Special	<input type="checkbox"/>
Other	<input type="checkbox"/>
Accounting Codes	
Dist	Final and/or Special
A-1	



CONTENTS

	<u>Page</u>
PREFACE . . . . .	1
INTRODUCTION . . . . .	3
PURPOSES OF THESE EXPERIMENTS . . . . .	4
PREVIOUS STUDIES . . . . .	4
EVIDENCE FROM BOND STRENGTH . . . . .	5
STUDIES OF CHLORIDE DISTRIBUTION . . . . .	6
CONCLUSIONS . . . . .	8
REFERENCES . . . . .	10
TABLES 1-3	
FIGURES 1-7	
APPENDIX A: GROUT COMPONENTS AND CURING CONDITIONS . . . . .	A1

DISTRIBUTION OF CHLORIDE IN A SALT-SATURATED GROUT  
IN CONTACT WITH ROCK SALT

Introduction

1. The first repository for permanent disposal of radioactive wastes from defense-related nuclear activities in the U.S. will be deep beneath the desert of southeastern New Mexico, in thick, relatively dry layers of rock salt. Rock salt is composed primarily of the mineral halite (NaCl). Plugging and sealing of access shafts and other penetrations, through the hundreds of meters of various rock types at and above the repository level, will require large volumes of grout and concrete. The most critical materials in the total seal system are those that will be in contact with the rock salt that actually encloses the waste canisters. Mixing water for the cement-based grout and concrete will be salt saturated, so the water in the plugging material does not dissolve the water-soluble host rock.

2. The factors most likely to detract from desired seal properties must be known, for design of seal materials and prediction of their performance for hundreds or thousands of years into the future. One such factor is the location and distribution of chloride ions ( $\text{Cl}^-$ ). Substitution of chloride ions into hydrated cement phases not only changes their chemical composition, but also changes the physical and mechanical properties of the resulting solid (Ogawa and Roy, 1982; Rock and Lukas, 1982; Midgely and Illston, 1984). In the case of salt-saturated grout in contact with rock salt, there are unlimited supplies of sodium and chloride ions, with the potential to affect the long-term stability and effectiveness of plugs and seals. Knowledge of location and movement of chloride ions in cement-based materials, the properties of which are

readily changed by chlorides, is a crucial part of long-range prediction of the safety of a repository.

#### Purposes of these Experiments

3. We designed experiments to explore the possibility of movement of important ions across the interface between grout or concrete and rock salt, and to develop data to help answer the following questions:

a) What tests or observations of samples having an interface between grout and rock salt might indicate whether or not there was any ion migration, or other evidence of chemical bonding? In the present case of salt-saturated grout to rock salt, any such chemical transfer was assumed to involve sodium and chloride ions.

b) Is chloride moving within the grout, or across the interface, or both; or is the grout unaffected? What is the potential for phase transformation after hardening of the cementitious material?

#### Previous Studies

4. Earlier research at The Pennsylvania State University (PSU) had been interpreted as showing minimal chemical interaction between cementitious plugs of various salt grouts and bedded salts. Materials studied had included a plug recovered from a potash mine after nearly 20 years in place (Wakeley et al, 1981), and mixtures intended for use in evaporite strata in New Mexico and north Texas (Wakeley and Roy, 1983, 1984). One objective of geochemical portions of those studies was to trace movement of chloride and other major ions over a microscopic distance, only a few tens of micrometres to either side of the interface between rock salt and NaCl-saturated grout. In retrospect, failure to detect decisive movement of ions may be attributed to the difficulty of having the critical substance ( $\text{Cl}^-$ ) abundant on both sides of the interface, and to the very small areas studied.

### Evidence from Bond Strength

5. Other work had shown poor bonding between anhydrite and several grouts, with bonding that was apparently mechanical (Roy, Grutzeck, and Wakeley, 1983; Wakeley and Roy, 1984). More recent work at the Waterways Experiment Station (WES) had shown this same trend for bonding between grout and anhydrite rock, but had suggested that there might be some chemical bonding, and hence probably ion migration, between grout and rock salt. Evidence for this possibility came from results of shear tests along the interface between grout and rock. One group of specimens cast for these experiments (Figure 1) consisted of salt-saturated grout in contact with relatively pure rock salt (>90% halite). In the second group, cast in the same configuration, the rock was predominantly anhydrite with about 20% randomly distributed halite. Grout composition and curing conditions are summarized in Appendix A.

6. In tests of bond strength, the grout half of each sample was held rigidly in the test apparatus and load was applied to the rock (Figure 2). For grout-halite samples, load at failure, and thus bond strength, was more than twice the value obtained for the anhydrite rock and grout (Table 1). Samples failed by shear through the rock, leaving salt adhering to grout (Figure 3), and a pile of crushed salt from near the interface.

7. With the rock of mixed lithology, a lower load caused failure roughly along the plane of the interface (Figure 4). Where the rock was halite, bits of rock were left adhering to the grout. Where the grout had been in contact with anhydrite, there was a surface layer of gypsum.

8. In the case of grout in contact with rock salt, the bond, by whatever mechanism, is stronger than the compressive strength of the salt. The load that sheared the sample, rather than being bond strength, is the load required to shear the salt (Figure 5), with actual bond strength being greater than this. But where the rock is predominantly anhydrite, failure occurs along the interface because the bond to anhydrite is much weaker than the shear strength of the rock.

9. Although the preponderance of anhydrite controlled bond strength, bonding is far weaker to anhydrite than to halite on the same surface. If the bond against rock with mixed lithology were all mechanical, then this mechanical bond would have to be stronger in contact with halite than with anhydrite, which seems unlikely. This suggests a bond between salt grout and salt that is at least partly chemical, and that ions are moving either in the grout or across the interface or both.

#### Studies of Chloride Distribution

10. To explore further the possibility of chloride migration across the interface, we encased fragments of halite or anhydrite rock in salt-saturated grout, in cylindrical specimens 25 mm in diameter (Figure 5). From these, we cut disks a few millimeters thick for scanning electron microscopy (SEM) and energy-dispersive X-ray spectroscopy (EDX).

11. When the first samples for SEM were cut and vacuum dried, surfaces as seen using SEM were almost totally covered by an armor of salt crystals. There were few areas in which we could get chemical spectra of the paste. This armor was continuous from the interface outward, but became discontinuous toward the perimeter of samples (away from the rock). These holes through the armor provided windows to the grout below, framed

by salt ridges (Figure 6). The coating of salt apparently crystallized from salt-saturated water, drawn out of the sample during evacuation in preparation for SEM. Chemical spectra and appearance of areas of the grout showing through the windows suggested that these were discrete particles of unhydrated cement or fine aggregates.

12. Cracked areas in the salt crust near the interface were distributed in a pattern similar to that of the windows near the perimeter (Figure 7). These appeared to be the same types of particles, only near the interface they were largely covered by salt that had been drawn out of the sample with evaporating water. In any case, there appeared to be more salt armor on the sample surface near the interface than at a distance from it, indicating that there had been more salt in the paste near the interface.

13. In order to study the grout, and especially for better opportunities to collect chemical spectra of hydration products, we ground off the salt armor, assuming that most of the free water already had been drawn out of the samples and that the armor would not form under vacuum a second time. This turned out to be approximately true, although the second surface showed some salt crystallization, especially near the rock interface. Areas of hydration products became clearly visible with the salt armor removed. Elemental maps routinely showed  $\text{Cl}^-$  as a component of hydration products. Also, chemical spectra collected on hydration products seemed to be showing ample  $\text{Cl}^-$  near the halite interface, and far less  $\text{Cl}^-$  at the edges of samples.

14. To explore this tendency further, we collected multiple spectra from EDX, in each of three regions of several samples. These regions were: 1) very near the interface (within 4 to 5 micrometres); 2) at the midpoint between the interface and the perimeter of the sample; and 3) near the edge

of the grout, in each case on what we identified as hydration products. Then for each of these spectra, we ran a no-standard analysis (Princeton Gamma Tech Microanalysis System), to determine relative amounts of six elements identified in the spectra. From each sample spectrum, the program calculates intensities of each element relative to the value of the element closest to its pure-element intensity. The spectra for interface, mid-point, and edge gave three groups of values for each element. The average intensity, or [K], values for each element were compared among groups, that is, Cl at in the interface to Cl at the middle and edge, Ca at the interface to Ca at the middle and edge, and so forth.

15. Average [K] values for all samples for Cl, Ca, and Si, in three groups according to distance from the interface, are given in Table 2. These values show higher levels of Cl near the contact with halite, and more Ca away from the interface. Then we compared average ratios of Cl to Ca from the interface to those at the midpoint and edge. The differences were highly statistically significant (Table 3). Although the difference in average Cl/Si ratio was not significant between the interface and edge groups, average ratios of Cl to Si were significantly different between the interface and midpoint. These trends suggesting a concentration of Cl near the interface did not appear in parallel studies of specimens having either interfaces with anhydrite, or no enclosed rock interface.

#### Conclusions

16. Shear strength of samples of salt-saturated grout in contact with halite and anhydrite suggests that bonding between grout and halite may be partly chemical bonding.

17. Salt armor on cut surfaces of samples with halite/grout interfaces forms by evaporation of water from the NaCl-saturated grout.

Its distribution suggests either (a) that the grout is richer in NaCl near the interface; or (b) that evacuation draws evaporable water from deeper in the grout in the zone near the interface.

18. Distribution of elements away from the interface in the grout suggests that the grout is richer in Cl near the interface. This represents a change from the roughly uniform distribution of Cl in salt-saturated grout without enclosed rock salt.

19. The apparent redistribution of important ions in these samples suggests that ion migration is occurring, and the resultant concentration of chloride is at least partially controlled by the proximity of rock salt.

## References

- Midgley, H. G. and J. M. Illston. 1984. "The penetration of chlorides into hardened cement pastes," Cement and Concrete Research Vol 14, pp 546-558.
- Ogawa, K. and D. M. Roy. 1982. "C<sub>4</sub>A<sub>3</sub>S hydration, ettringite formation, and its expansion mechanism: III. Effect of CaO, NaOH, and NaCl; conclusions," Cement and Concrete Research Vol 12, pp 247-256.
- Rock, R. and W. Lukas. 1982. "Phase change due to the subsequent action of chloride on hydrates of the system C<sub>3</sub>A-CaSO<sub>4</sub>-Ca(OH)<sub>2</sub>," Zement-Kalk-Gips No. 8, pp 205-206.
- Roy, D. M., M. W. Grutzeck, and L. D. Wakeley. 1983. "Selection and durability of seal materials for a bedded salt repository," ONWI-479, Office of Nuclear Waste Isolation, Battelle Memorial Institute, Columbus, OH.
- Wakeley, L. D., D. M. Roy, and M. W. Grutzeck. 1985. "Cementitious mixtures for sealing access shafts and boreholes through evaporite and clastic rocks in a radioactive-waste repository," pp 951-958 in The Scientific Basis for Nuclear Waste Management, Proceedings Vol 44, Materials Research Society.
- Wakeley, L. D. and D. M. Roy. 1983. "Experimental concretes for sealing a radioactive-waste repository in evaporite strata," Cement and Concrete Research Vol 13, pp 97-106.
- Wakeley, L. D., B. E. Scheetz, M. W. Grutzeck, and D. M. Roy, 1981. "Characterization of samples of a cement-borehole plug in bedded evaporites from southeastern New Mexico," Cement and Concrete Research Vol 11, pp 131-142.

TABLE 1

Shear Strength\* Values for Specimens Tested as Shown in Figure 2.

	Halite/Grout	Anhydrite/Grout
Shear strength	3.2 MPa (460 psi)	1.3 MPa (185 psi)

\*Load at failure ÷ vertical cross-sectional.

TABLE 2

Average Intensity (K) Values from No-standards Analysis for Si, Cl, and Ca at Three Locations Relative to Halite Interface

## SUMMARY STATISTICS\*

ION & GROUP**	MEAN	STD. DEV.	MINIMUM	MAXIMUM
Si-1	0.104	0.030	0.057	0.149
Cl-1	0.222	0.028	0.196	0.289
Ca-1	0.216	0.033	0.163	0.277
Si-2	0.119	0.026	0.081	0.174
Cl-2	0.155	0.023	0.113	0.188
Ca-2	0.236	0.025	0.190	0.275
Si-3	0.096	0.021	0.065	0.124
Cl-3	0.174	0.028	0.102	0.198
Ca-3	0.263	0.048	0.216	0.384

\*Data from standardless analysis in energy-dispersive X-ray spectroscopy, Princeton Gamma Tech.

\*\*Group 1 is interface, Group 2 is midpoint, Group 3 is near edge of samples.

TABLE 3

Ratios of (K) Values for Three Groups of Samples

RATIO*	MEAN	STD. DEV.	MINIMUM	MAXIMUM
Cl-1/Si-1	2.377	1.008	1.329	4.321
Cl-1/Ca-1	1.040	0.146	0.770	1.234
Cl-2/Si-2	1.398	0.474	0.710	2.090
Cl-2/Ca-2	0.664	0.112	0.442	0.851
Cl-3/Si-3	1.906	0.579	1.226	2.919
Cl-3/Ca-3	0.688	0.178	0.266	0.850

\*Highly significant differences between Cl-1/Ca-1 and both Cl-2/Ca-2 and Cl-3/Ca-3; and between Cl-1/Si-1 and Cl-2/Si-2, in tests of differences between two group means.

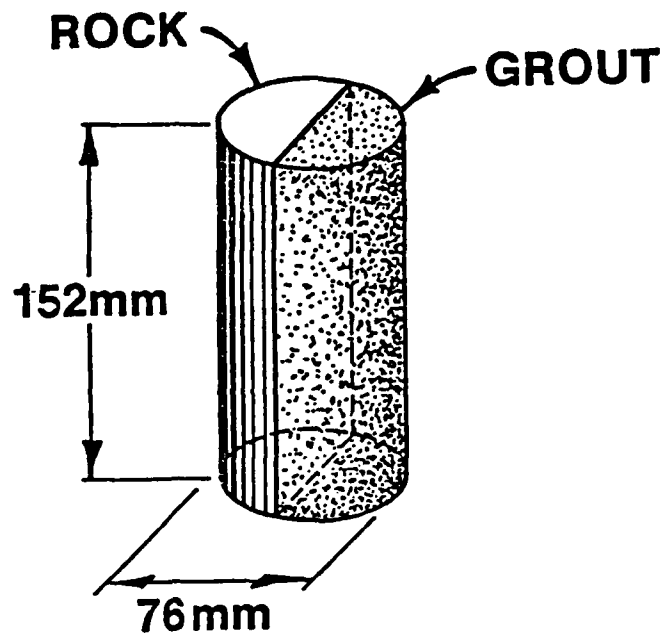

Figure 1. Configuration of specimens with planar interface.

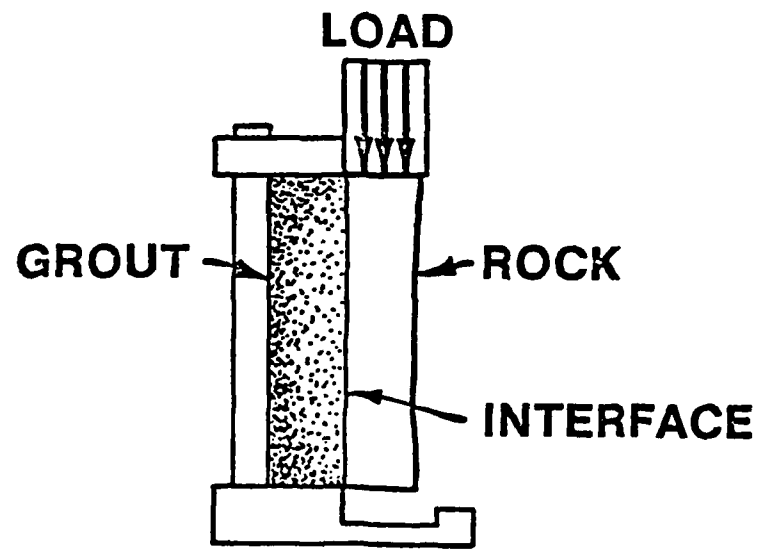

Figure 2. Test configuration for shear testing (after CRD-C 89, Handbook for Concrete and Cement, U.S. Army Engineer Waterways Experiment Station, Vicksburg, Miss.).

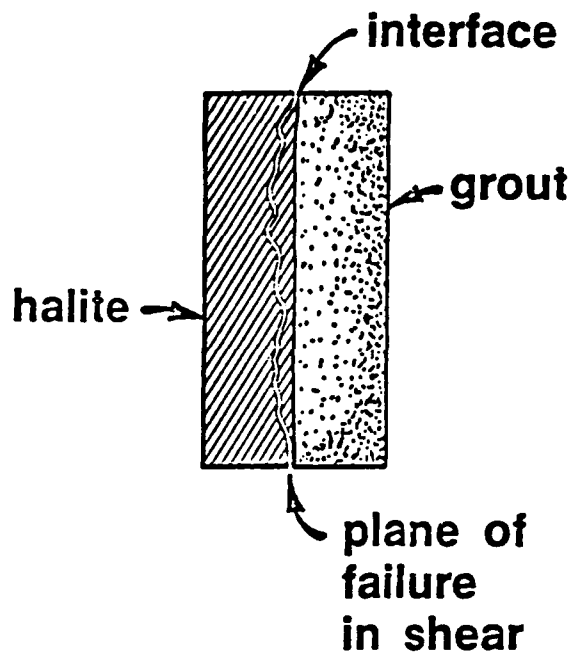

Figure 3. Failure in shear through halite, halite/grout specimens.

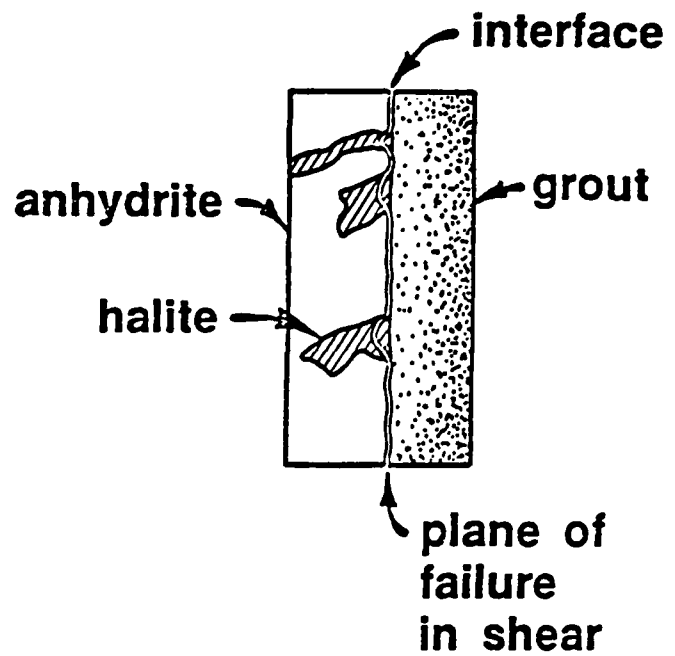

Figure 4. Failure in shear along interface, anhydrite/grout specimens.

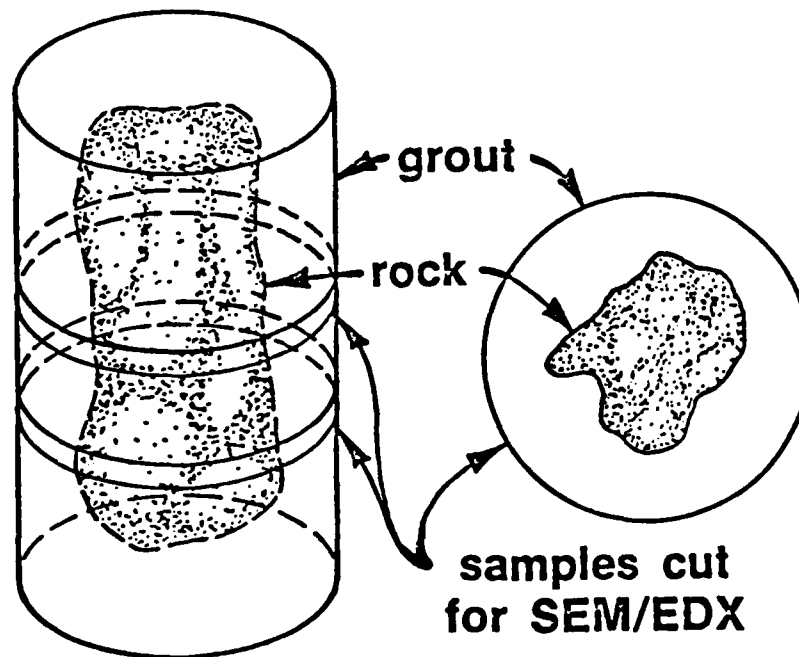

Figure 5. Configuration of 2.5 centimeter-diameter specimens from which samples were taken for SEM/EDX studies.

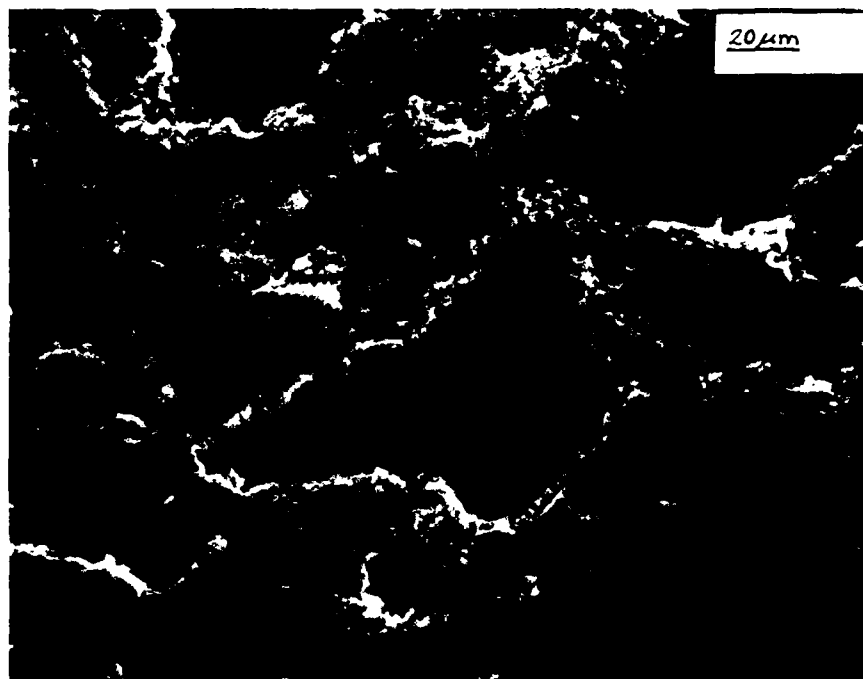

Figure 6. Particles visible through windows in salt crust near perimeter of sample.

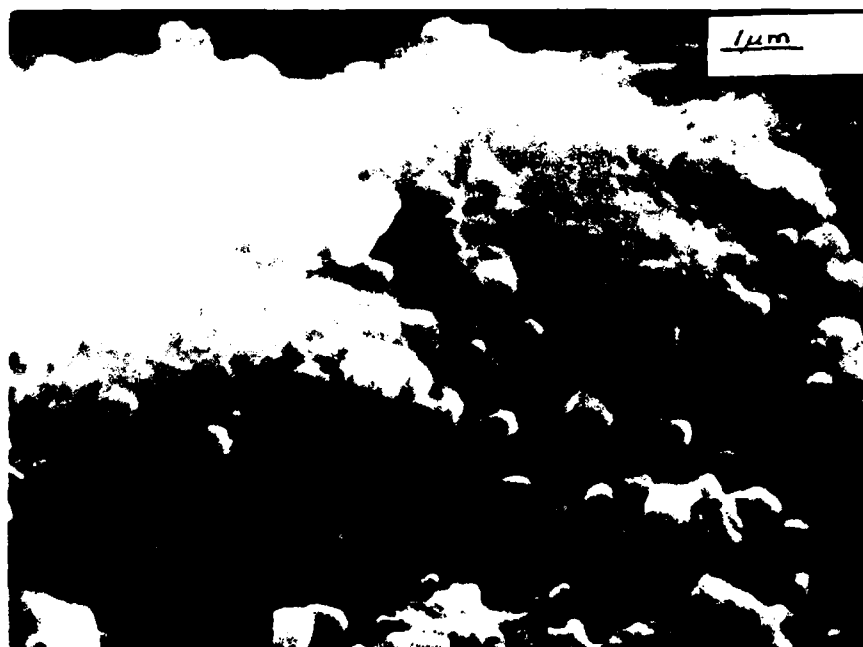

Figure 7. Cracks in salt crust near interface with halite.

APPENDIX A

Grout Components and Curing Conditions

---

1. Component	Weight Percentage*
Class H Cement	29.04
Class F Fly Ash	9.78
Expansive Additive	3.43
Water-Reducing Admixture	0.64
Crushed Salt	5.69
Defoaming Agent	0.11
Sand	29.99
Silica Flour	6.01
Water	15.32

---

\*Percentage of total mass.

---

---

2. Curing and Storage Conditions.

---

Time	50 to 80 days
Temperature	24 C
Humidity	>95% rh
Sealed plastic molds and vials	

---

**END**

**FILMED**

*1-86*

**DTIC**