

UNCLASSIFIED

12

ARL-AERO-PROP-TM-424

AR-004-011



DEPARTMENT OF DEFENCE  
DEFENCE SCIENCE AND TECHNOLOGY ORGANISATION  
AERONAUTICAL RESEARCH LABORATORIES  
MELBOURNE, VICTORIA

AD-A161 906

20000801186

Aero Propulsion Technical Memorandum 424

FURTHER DEVELOPMENTS IN A PARAMETRIC STUDY  
OF RAMROCKET PERFORMANCE

Reproduced From  
Best Available Copy

by  
Lincoln Ern

DEC 03 1985

Approved for Public Release

THE UNITED STATES NATIONAL  
TECHNICAL INFORMATION SERVICE  
IS AUTHORIZED TO  
REPRODUCE AND SELL THIS REPORT

(C) COMMONWEALTH OF AUSTRALIA 1985

DTIC FILE COPY

APRIL 1985

UNCLASSIFIED

85 12 2 14 9

DEPARTMENT OF DEFENCE  
DEFENCE SCIENCE AND TECHNOLOGY ORGANISATION  
AERONAUTICAL RESEARCH LABORATORIES

Aero Propulsion Technical Memorandum 424

FURTHER DEVELOPMENTS IN A PARAMETRIC STUDY  
OF RAMROCKET PERFORMANCE

by

Lincoln Erm

SUMMARY

The performance of a ramrocket is estimated for a set of reference conditions and then the effect on performance of variable altitude, radial injection of the primary jet, variable intake pressure recovery and different levels of secondary combustion efficiency are each examined in turn. The results are presented graphically in terms of specific impulse.



© COMMONWEALTH OF AUSTRALIA 1985

---

POSTAL ADDRESS: Director, Aeronautical Research Laboratories,  
P.O. Box 4331, Melbourne, Victoria, 3001, Australia.

CONTENTS

PAGE NO.

NOTATION

1. INTRODUCTION.....1

2. FEATURES OF THEORETICAL MODEL.....1

    2.1 Principle of Operation.....1

    2.2 Propellant Properties and Secondary Combustion.....2

    2.3 Evaluation of Flow Variables.....3

3. RESULTS AND DISCUSSION.....4

    3.1 Reference Characteristics.....4

    3.2 Effect of Altitude.....4

    3.3 Radial Injection of Primary Jet.....5

    3.4 Effect of Intake Pressure Recovery.....6

    3.5 Effect of Secondary Combustion Efficiency.....7

4. CONCLUSIONS.....7

5. ACKNOWLEDGEMENT.....8

REFERENCES

FIGURES

DISTRIBUTION

DOCUMENT CONTROL DATA

Acquisition For	
NTIS CRA&I	<input checked="" type="checkbox"/>
DTIC TAB	<input type="checkbox"/>
Unannounced	<input type="checkbox"/>
Justification	
By	
Distribution	
Availability Codes	
Dist	Availability for Control
A-1	



## NOTATION

Symbol Definition

A Flow area measured normal to flow direction.  $m^2$ .

L Variable factor by which loss terms in intake pressure recovery laws are multiplied.

M Mach number.

$\dot{m}$  Mass flow rate. kg/s.

P Total pressure. Pa.

p Static pressure. Pa.

R Gas constant. J/kg.K.

SI Specific impulse =  $(\dot{m}_4 V_4 - \dot{m}_1 V_1) / \dot{m}_2$ . N/(kg/s)

T Total temperature. K.

V Gas velocity. m/s.

$\gamma$  Specific heat ratio.

$n_{sc}$  Secondary combustion efficiency =  $\frac{\text{Actual temperature rise}}{\text{Ideal temperature rise}}$

$\mu$  Mass flow ratio =  $\dot{m}_2'' / \dot{m}_2'$

### Subscripts

1-4 Refers to flow stations 1 to 4 in Fig. 1.

### Superscripts

' Refers to primary flow at station 2.

'' Refers to secondary flow at station 2.

## 1. INTRODUCTION

The work described in this report is an extension of earlier work by Erm (1983), which involved initial development of a theoretical model for calculation of ramrocket performance for a range of flight conditions and with different geometric constraints. The current investigation considers the effects of additional flight conditions and flow constraints, including variable altitude, radial injection of the primary jet, variable intake pressure recovery and different levels of secondary combustion efficiency.

Other investigators, including Rickeard (1973) and Ramanujachari et. al. (1981) have also undertaken studies to predict ramrocket performance, using similar models, but with slightly different approaches. Their work forms a basis for comparison with the method of the present study.

## 2. FEATURES OF THEORETICAL MODEL

### 2.1 Principle of Operation

A diagrammatic representation of the idealised ramrocket, showing stations along the flow path, is given in Fig. 1. A solid-fueled rocket produces fuel-rich exhaust products which are expanded through the rocket nozzle into a mixing tube/combustion chamber. This primary flow mixes with secondary air flow delivered from the atmosphere by an intake/diffuser system, and further combustion takes place. The mixture is then expanded through the exhaust nozzle to atmosphere.

An important feature of a ramrocket (compared with, say, a liquid-fueled ramjet) is the momentum of the primary (rocket) jet. Depending upon propellant properties and flight speed, this can contribute significantly to the secondary combustion chamber total pressure and, in turn, total thrust. The theoretical model accommodates both axial and radial injection of the primary jet.

## 2.2 Propellant Properties and Secondary Combustion

The propellant considered in this investigation was the same as that used in the earlier work. The propellant was a composite type containing 75% ammonium perchlorate, 20% binder and 5% aluminium. Gas conditions or constants at the primary nozzle exit plane were  $T_2^* = 2555$  K,  $P_2^* = 5066$  kPa (50 atmospheres),  $\gamma_2^* = 1.244$  and  $R_2^* = 365$  J/kg.K. These parameters remained constant for all operating conditions considered, but  $M_2^*$  was allowed to vary and was determined by assuming that  $p_2^*$  was equal to  $p_2^{\#}$ . The temperature rise resulting from combustion of the primary efflux and secondary air, as well as the gas constants of the final combustion products, were again taken from the study of Stewart et. al. (1976) who based these data on the computer programme of Gordon & McBride (1971). The data are shown plotted against air mass flow ratio,  $\mu$ , in Fig. 2. For present purposes these curves are assumed to be independent of both temperature and pressure of the inlet air and therefore, for given  $\mu$ , independent of variables such as flight speed and altitude.

As a basically conventional rocket propellant, the assumed formulation does not have the fuel-rich properties of a purpose-designed ramrocket propellant. Whilst this is not wholly inappropriate for the comparatively low flight speed range to be considered, wherein the momentum of the primary jet can be relatively important to overall performance, it can be expected to yield significantly lower levels of overall specific impulse at higher flight Mach numbers than would more fuel-rich propellants. This aspect will be explored in subsequent development of the model and is not treated here.

Propellant composition constitutes the main difference between the current study and those of Rickeard (1973) and Ramanujachari et. al.(1981). The propellant of Ramanujachari et. al., although its composition was not actually given, was stated to be metallised and highly fuel-rich. The propellant used by Rickeard was a mixture of hydrazine ( $N_2H_4$ ) and nitrogen tetroxide ( $N_2O_4$ ). The rocket was operated with an excess of hydrazine to provide a source of fuel. These differences make it impossible to make a sensible comparison between the quantitative results of the three studies.

As in the current investigation, Ramanujachari et. al. used the computer code of Cordon & McBride (1971) to determine details of combustion products. Rickeard, however, used a simple chemistry model.

### 2.3 Evaluation of Flow Variables

The calculation procedure used the same equations, involving conservation of mass, momentum and energy, as were described in detail by Erm (1983). The same one-dimensional, frictionless flow assumptions employed in the earlier study are used here. The static pressure across both inlet and exit planes (1 and 4 respectively) was assumed to be equal to atmospheric. In other words there was no pre-entry diffusion of the inlet air and the final nozzle was always correctly expanded.

The model could accommodate either constant area, i.e.  $A_3 = A_2^i + A_2^n$  or constant pressure, i.e.  $p_3 = p_2^n$ , mixing and combustion. Both cases have been explored and compared in detail in the earlier study, and were found to yield identical levels of performance provided that optimum geometries were considered. This conclusion is consistent with that arrived at by Kentfield & Barnes (1972) in calculating the performance of thrust augmenting ejectors. For the present purposes, then, consideration is confined to constant area configurations, i.e. cylindrical combustors, which are more convenient from the engineering viewpoint.

Rickeard (1973) and Ramanujachari et. al. (1981) used similar geometrical models but their handling of component performances differed. For example, intake losses in the present study were included in the form of an empirical Mach number function (see Section 3.4), whilst Rickeard used a somewhat simpler law and Ramanujachari et.al. opted for calculating losses using theoretical shock relationships. Ramanujachari et. al. also divided the combustion chamber into three parts, viz. mixing cum diffusion section, pressure loss section and heat addition section, and so included frictional losses in their analysis.

### 3. RESULTS AND DISCUSSION

#### 3.1 Reference Characteristics

As a basis for subsequent evaluation of the effects of different flight conditions and flow constraints, a reference set of performance characteristics is given in Fig. 3. These were calculated for sea-level conditions, axial injection of the primary jet, "standard" intake pressure recovery (as defined in Section 3.4) and 90% secondary combustion efficiency.

The solid curves indicate the variation with flight Mach number of optimum values of secondary/primary mass flow ratio and diffuser exit Mach number, and corresponding internal performance in terms of specific impulse. Included for comparison is the theoretically ideal performance of the "rocket", i.e. the primary gas generator, in isolation.

It is important to note that the curves in Fig. 3 represent optimum values for each given flight Mach number, which implies varying geometry with varying Mach number. This also applies to subsequent figures.

The diffuser exit Mach number,  $M_2^*$ , was allowed complete freedom to adopt an optimum value but since this could result in impractically low values of  $M_2^*$ , a second set of curves was calculated with  $M_2^*$  fixed at 0.2. These appear as broken lines in Fig. 3; as can be seen, this constraint had minimal effect on specific impulse for the range of conditions considered.

#### 3.2 Effect of Altitude

The performance was calculated for atmospheric conditions at 5000 and 10000 m altitude as well as at sea level. The effect of increased altitude was to decrease both the ambient temperature and pressure but not the combustion temperature rise, so long as  $\mu$  was fixed. The relevant input parameters at both sea level and altitude are given in Table 2.

TABLE 2  
Ambient Atmospheric Conditions

Altitude m	$T_1$ K	$P_1$ kPa	$\gamma_1$	$R_1$ J/kg.K
0	288	101	1.4	287
5000	256	54	1.4	287
10000	223	26	1.4	287

The performance of both the ramrocket and the isolated rocket at three different altitudes is given in Fig. 4.

### 3.3 Radial Injection of Primary Jet

The performance was determined for the case when the primary jet entered the secondary combustion chamber in a radial direction, thereby making no contribution to the axial momentum as it did in the reference case and thus reducing the performance. In practice this might be accompanied by a superimposed improvement in performance as a consequence of improved mixing and combustion associated with radial injection, but the model was not able to take account of this.

The performance characteristics with radial injection are compared with the reference characteristics in Fig. 5. It can be seen that with radial injection, the optimum performance occurred when  $M_2^*$  had an unrealistic value of 0.001 (effectively zero), which was its starting value in the performance calculations. The reason for this can be found in the fact that optimum performance, as outlined in Section 2.3 and discussed in more detail by Erm (1983), always coincided with constant pressure combustion (i.e.  $p_3 = p_2^*$ ). For the reference (axial injection) case, the initial value of  $p_3$  calculated for  $M_2^* = 0.001$  was greater than  $p_2^*$ . As the value of  $M_2^*$  was incremented, the calculated values of  $p_3$  and  $p_2^*$  both decreased but since  $p_3$  decreased at a faster rate than  $p_2^*$ , at some stage (generally near  $M_2^* = 0.16$ ) the two pressures became

equal, at which point optimum performance occurred. For the radial injection case, however, equality of  $p_3$  and  $p_2''$  occurred only at  $M_2'' = 0.0$ , at which condition "optimum" performance was therefore registered.

For a more realistic comparison,  $M_2''$  was fixed at 0.2, at which condition there was a significant thermodynamic penalty associated with radial injection. This increased with decreasing flight speed, to the extent that the performance became inferior to that of the isolated rocket just under  $M_1 = 1.0$ . It must be reiterated that any counteracting improvement due to fluid dynamic effects on secondary combustion efficiency could not be addressed with the current one-dimensional flow model. However, even when the secondary combustion efficiency was increased to 100% for radial injection, the resulting performance was still inferior to the reference case (see Fig. 5).

### 3.4 Effect of Intake Pressure Recovery

The reference performance results were determined by using intake pressure recovery laws as shown below:

$$P_2'' = P_1 \quad \text{for } 0.0 < M_1 < 1.0$$

$$P_2'' = P_1 (1.0 - 0.076 (M_1 - 1.0)^{1.35}) \quad \text{for } 1.0 < M_1 < 2.0$$

In order to determine the effect on performance of varying the level of intake pressure recovery, the second of these relationships, which is the only one containing loss terms, was modified as follows:

$$P_2'' = P_1 (1.0 - 0.076 L (M_1 - 1.0)^{1.35}) \quad \text{for } 1.0 < M_1 < 2.0$$

where  $L$  is a variable factor by which the loss terms in the equation are multiplied. The performance characteristics calculated using the modified pressure recovery law appear in Fig. 6 for two different values of  $L$ , together with the reference characteristics ( $L = 1$ ). Clearly the level of

intake loss is not a major factor when assessing ramrocket performance, at least for the range of conditions considered, since even if the loss terms are increased by 100 per cent ( $L = 2$ ), the specific impulse at a flight Mach number of 2.0 is reduced by only about 3%. This conclusion might well be different for the radial primary jet injection case, and for higher flight Mach numbers.

### 3.5 Effect of Secondary Combustion Efficiency

The reference performance characteristics correspond to a secondary combustion efficiency,  $\eta_{sc}$ , of 90%. This meant that the actual temperature rise in the secondary combustion chamber was 90% of the ideal value. The temperature rise curves corresponding to  $\eta_{sc} = 80\%$  and  $70\%$  are given in Fig. 2 along with the 90% curve. The  $\gamma_3$  versus  $\mu$  and  $R_3$  versus  $\mu$  curves also shown on this figure, which were used when computing performance for  $\eta_{sc} = 90\%$ , were assumed to apply unchanged to the 80% and 70% cases. As shown in Fig. 7, the predicted performance deteriorated as the secondary combustion efficiency was reduced. For  $\eta_{sc} = 70\%$ , the optimum performance was reduced by 5% at  $M_1 = 0.4$  and by 11% at  $M_1 = 2.0$ .

## 4. CONCLUSIONS

Optimum values of ramrocket performance, in terms of specific impulse, were predicted for a range of flight conditions and with different imposed flow and geometric constraints. A reference set of performance characteristics was compared with characteristics calculated for variable altitudes, radial injection of the primary jet, variable intake pressure recovery and different levels of secondary combustion efficiency. The calculated reference specific impulse was 2512 N/(kg/s) at Mach 0.4 and 5595 N/(kg/s) at Mach 2.0.

The performance improved with increasing altitude and for altitudes of 5000 and 10000 m, the optimum values of specific impulse, compared with the sea-level reference case, increased by 4% and 8% respectively at Mach 0.4 and by 2% and 5% respectively at Mach 2.0.

The effect of changing from axial to radial injection was initially assessed by assuming that the secondary combustion efficiency,  $\eta_{sc}$ , remained at 90% as for the reference case. The "optimum" performance for radial injection with  $\eta_{sc} = 90\%$  occurred when the Mach number at the diffuser outlet,  $M_2^*$ , had the unrealistically low value of 0.001. When  $M_2^*$  was fixed at 0.2, the performance with radial injection was reduced by 7% at Mach 2.0 and 41% at about Mach 0.95 compared with the reference case. Below this latter Mach number the performance was inferior to that of the isolated rocket. When  $\eta_{sc}$  was increased to 100% and  $M_2^*$  was held fixed at 0.2, the performance with radial injection still remained inferior to the reference case at all flight Mach numbers. In this case the reduction in performance was 3% at Mach 2.0 and 39% at about Mach 0.9.

The results indicate that the level of intake recovery did not have a large effect on the predicted performance, at least for the range of conditions considered. At Mach 2.0, the fall off in specific impulse, compared with the reference case, was only 3% when the intake losses were increased by 100%.

As expected, the predicted performance dropped as the level of secondary combustion efficiency was reduced. For  $\eta_{sc} = 80\%$  and 70%, the optimum values of specific impulse compared with the 90% (reference) case fell by 2% and 4% respectively at Mach 0.4, and 5% and 11% respectively at Mach 2.0.

## 5. ACKNOWLEDGEMENT

The author gratefully acknowledges the valuable contributions of Mr. S.A. Fisher, for all of his help and continued support during the undertaking of this work.

## REFERENCES

- Erm, L. "A Parametric Study of Ramrocket Performance." ARL/ME Note 395, April 1983.
- Gordon, S. and McBride, B.J. "Computer Program for Calculation of Complex Chemical Equilibrium Compositions, Rocket Performance, Incident and Reflected Shocks, and Chapman-Jouguet Detonations." NASA SP-273, 1971.
- Kentfield, J.A.C., and Barnes, R.W. "The Prediction of the Optimum Performance of Ejectors." Proc Instn Mech Engrs, Vol. 186, pp 671-680, 1972.
- Ramanujachari, V., Krishnan, S., Padiyar, K.S., Natarajan, R., and Gupta, M.C. "Performance Analysis of Primary and Secondary Systems of a Rocket Ramjet Engine Burning Fuel-Rich Metallised Propellants." Fifth International Symposium on Air Breathing Engines. Bangalore, India, 1981.
- Rickeard, D., "A One-Dimensional Flow Model for an Air-Augmented Rocket." Journal of the British Interplanetary Society. Vol. 26, pp 18-27, 1973.
- Stewart, D.G., Frith, D.A., Fisher, S.A., and Bradfield, W.A. "Thrust Augmentation by Air Induction and Afterburning in Subsonic Rocket Propelled Vehicles." Third International Symposium on Air Breathing Engines, Munich, West Germany, 1976.

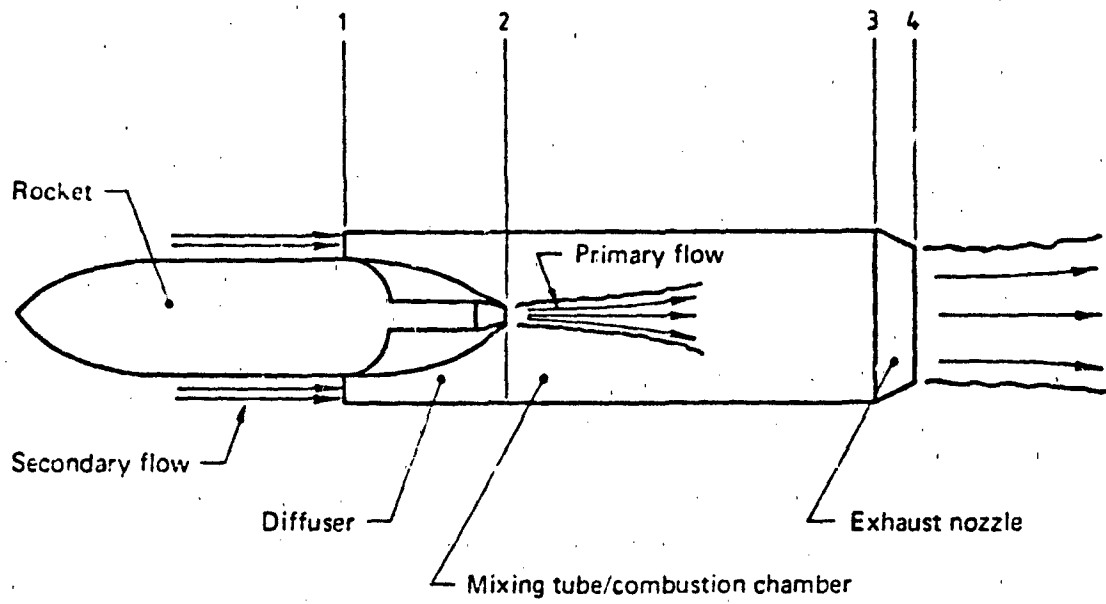

FIG. 1. DIAGRAMMATIC REPRESENTATION OF RAMROCKET SHOWING STATIONS ALONG FLOW PATH

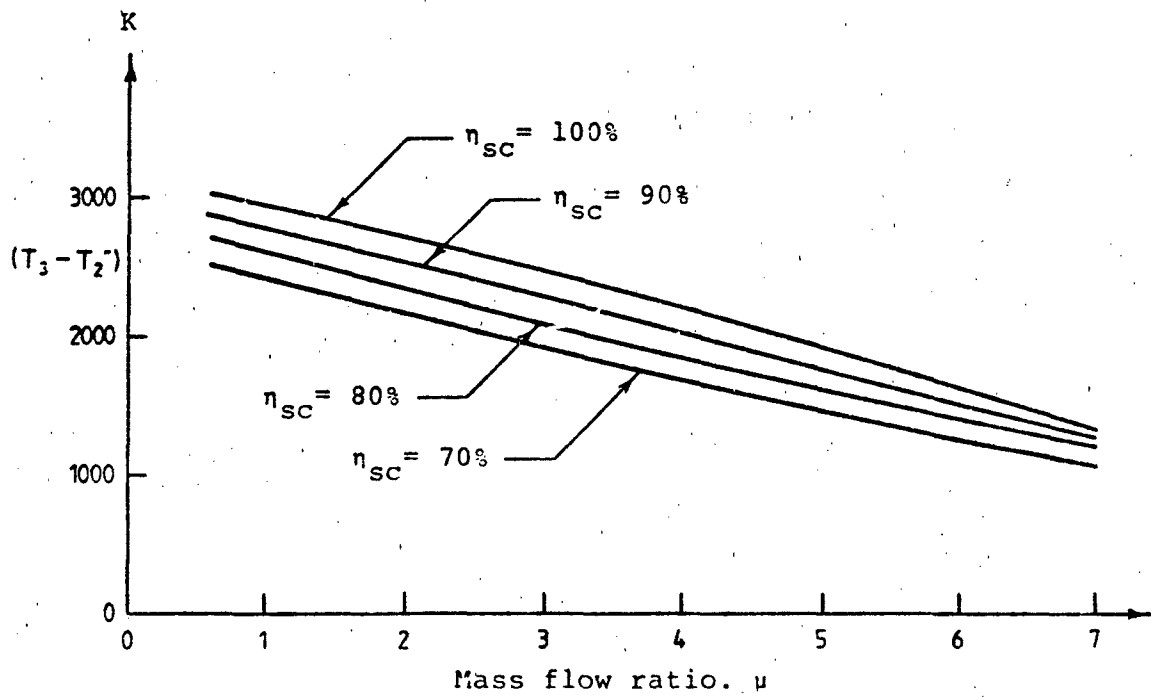
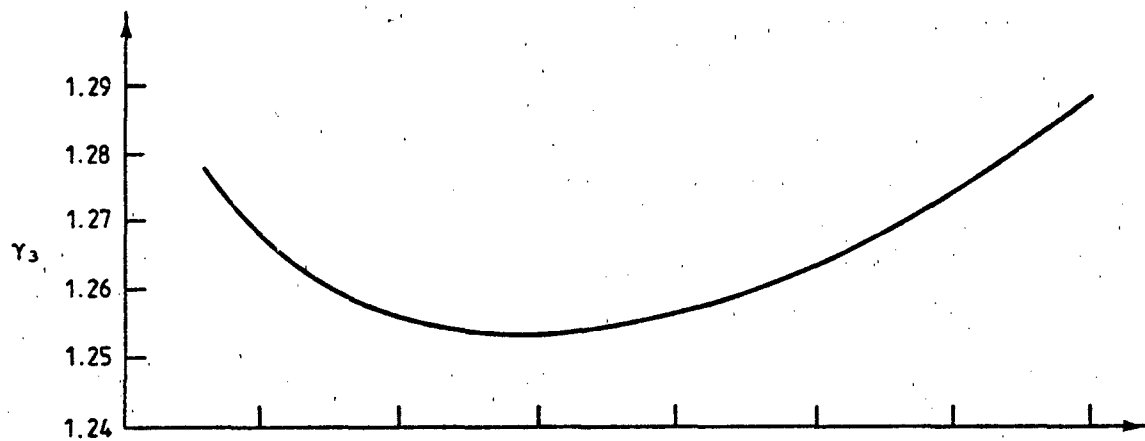
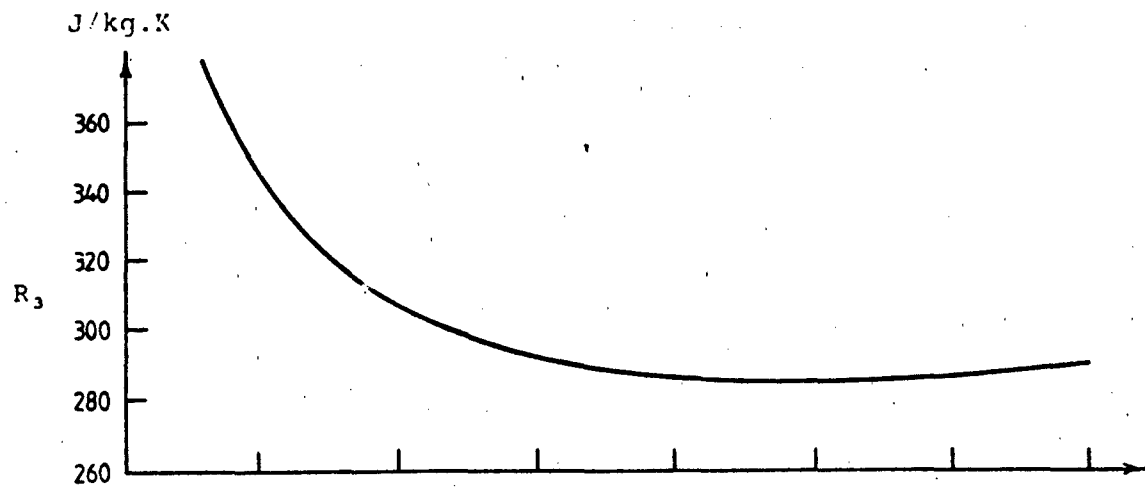
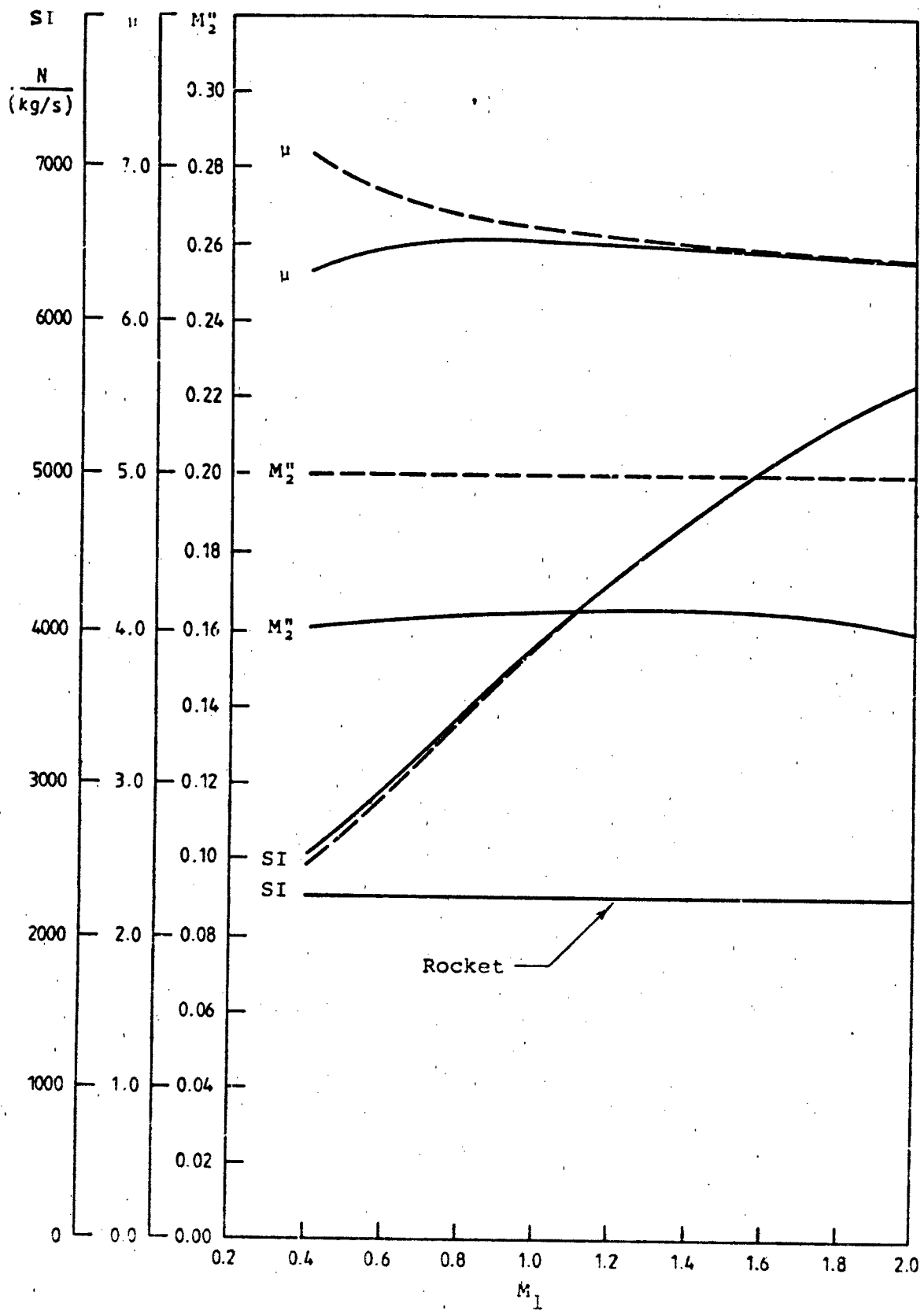

FIG. 2 CURVES USED TO DETERMINE PROPERTIES OF COMBUSTION PRODUCTS AT STATION 3.



——— Optimum performance curves with  $M_2$  unrestricted  
 - - - Optimum performance curves with  $M_2$  fixed at 0.2  
 FIG. 3 OPTIMUM VALUES OF  $SI$  AND CORRESPONDING VALUES OF  $\mu$  AND  $M_2$  VERSUS  $M_1$  FOR REFERENCE CONDITIONS.

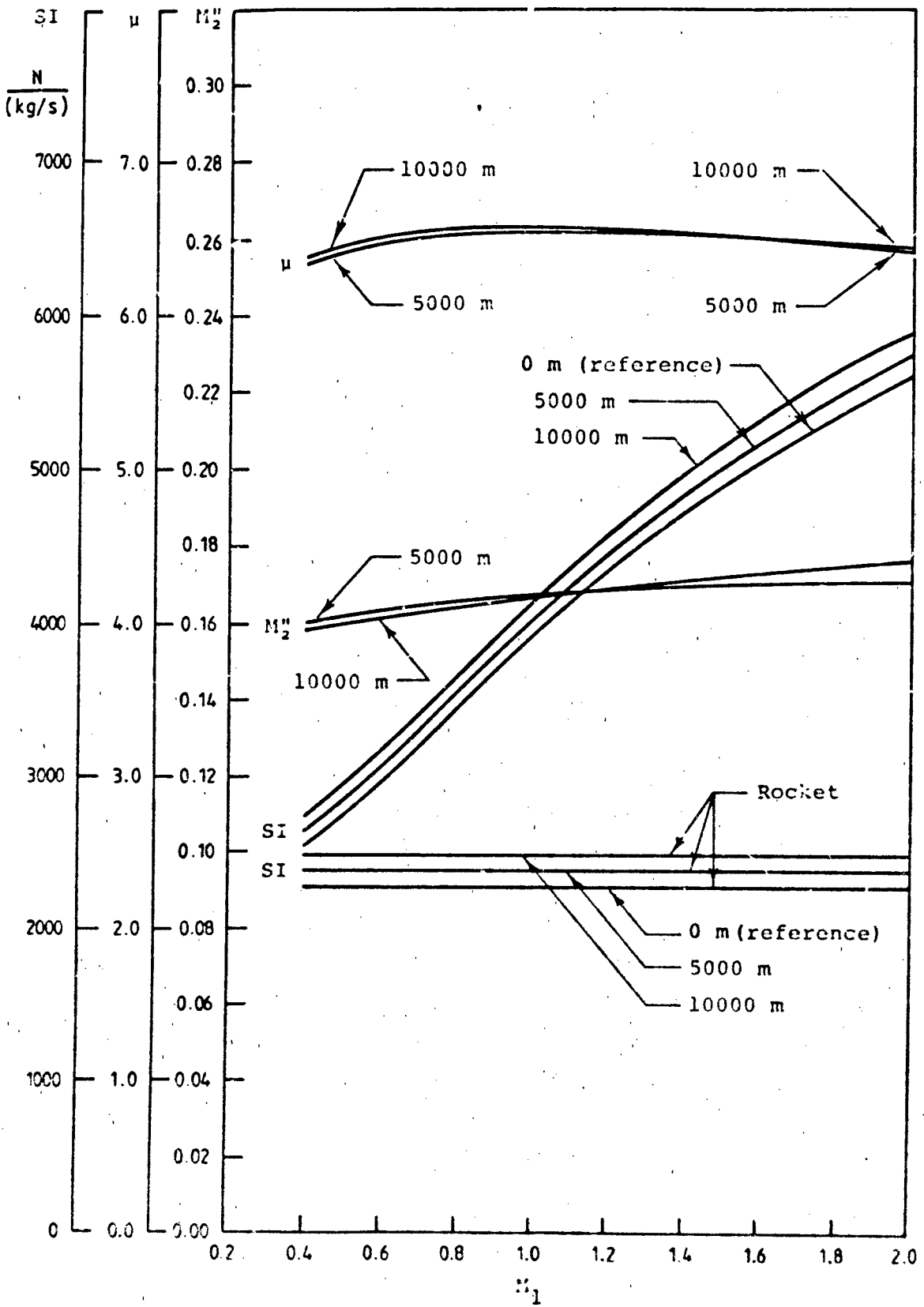
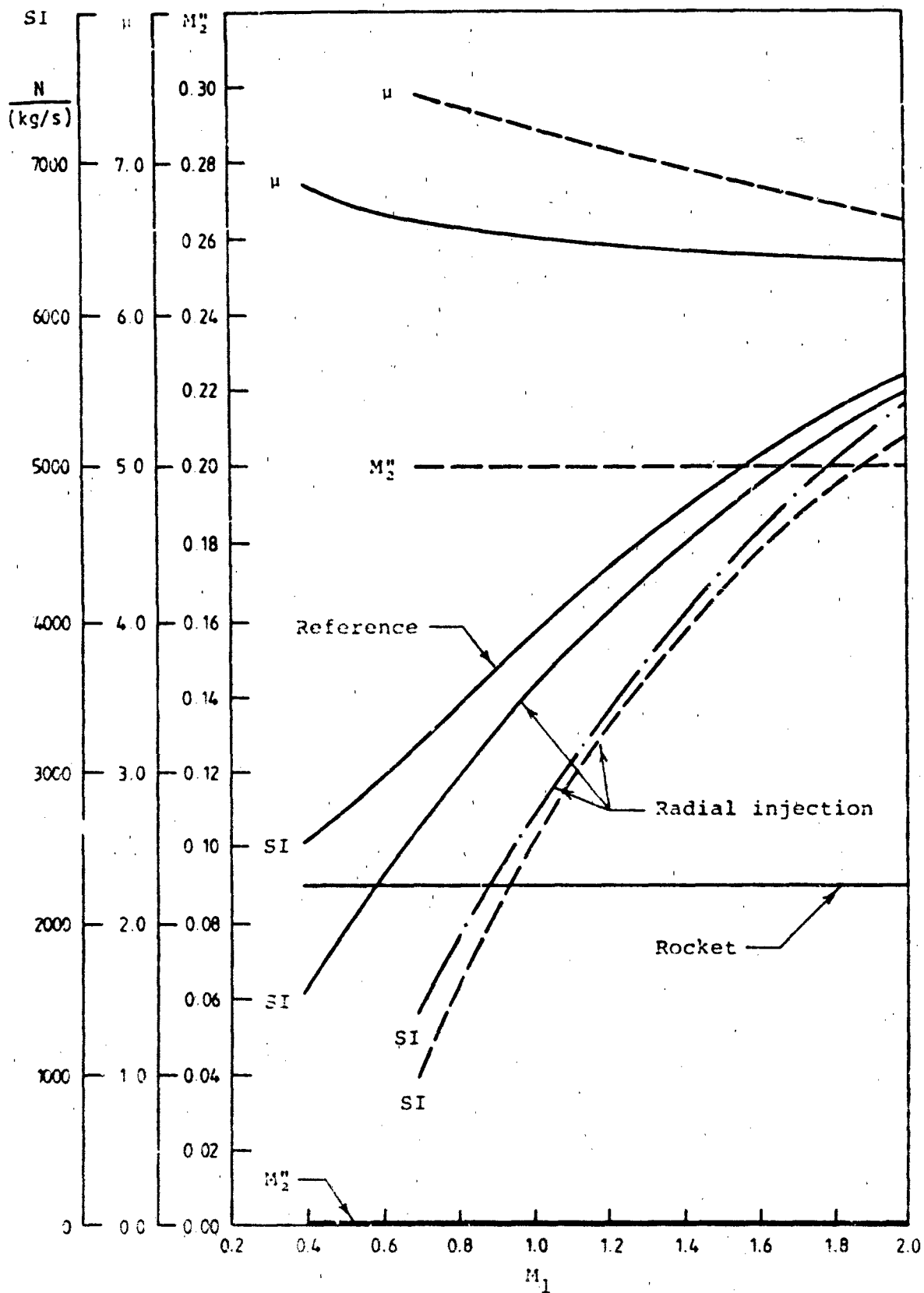

FIG. 4 OPTIMUM VALUES OF  $SI$  AND CORRESPONDING VALUES OF  $\mu$  AND  $M_2$  VERSUS  $M_1$  FOR 5000 m AND 10000 m ALTITUDE.



- Optimum performance curves with  $M_2^*$  unrestricted,  $\eta_{sc} = 90\%$
- - - Optimum performance curves with  $M_2^*$  fixed at 0.2,  $\eta_{sc} = 90\%$
- · - Optimum performance curve with  $M_2^*$  fixed at 0.2,  $\eta_{sc} = 100\%$

FIG. 5 OPTIMUM VALUES OF  $SI$  AND CORRESPONDING VALUES OF  $\mu$  AND  $M_2^*$  VERSUS  $M_1$  FOR RADIAL INJECTION OF PRIMARY JET.

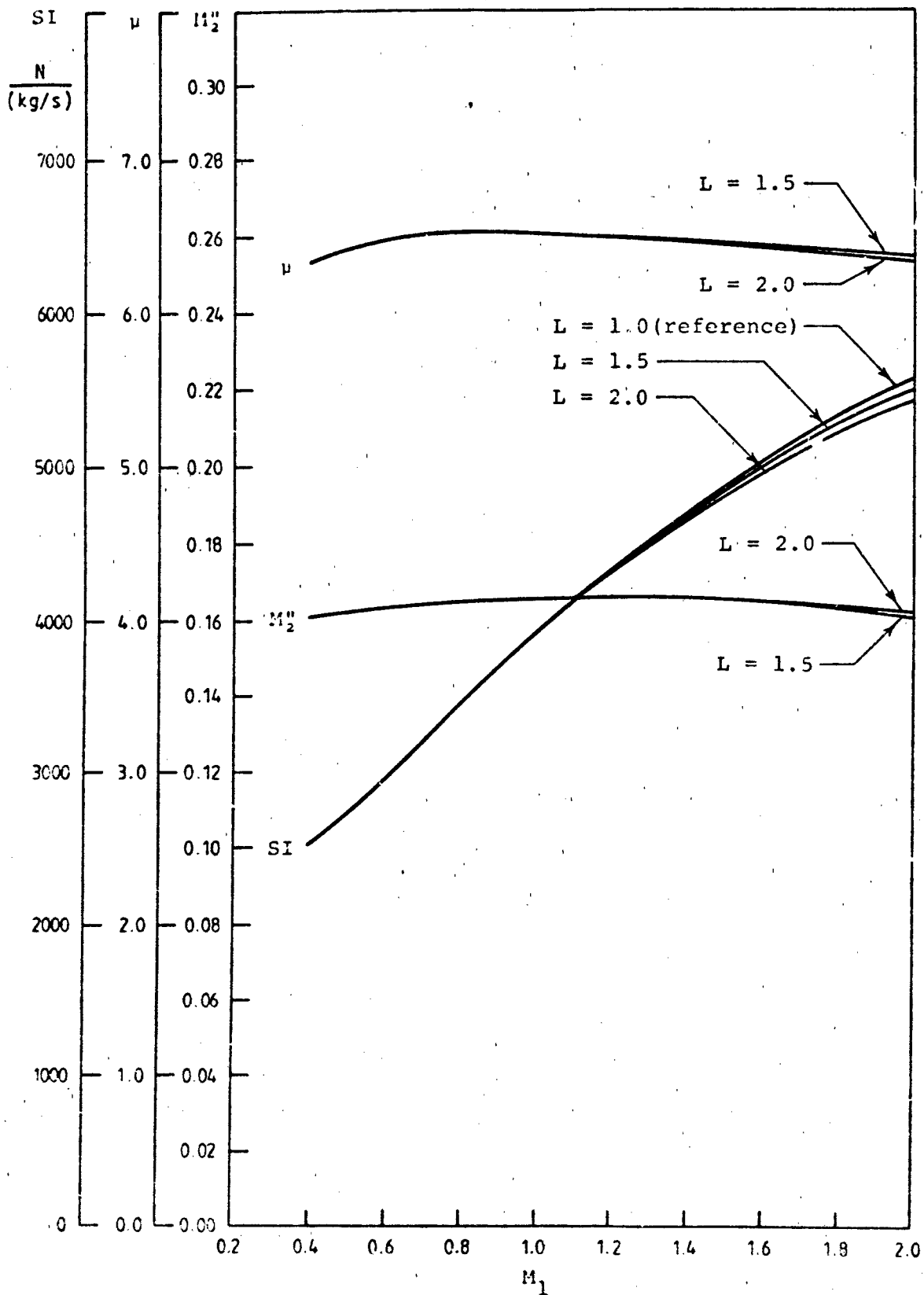

FIG. 6

OPTIMUM VALUES OF  $SI$  AND CORRESPONDING VALUES OF  $\mu$  AND  $M_2$  VERSUS  $M_1$  FOR 50% ( $L = 1.5$ ) AND 100% ( $L = 2.0$ ) INCREASE IN INTAKE LOSSES AT SUPERSONIC FLIGHT MACH NUMBERS.

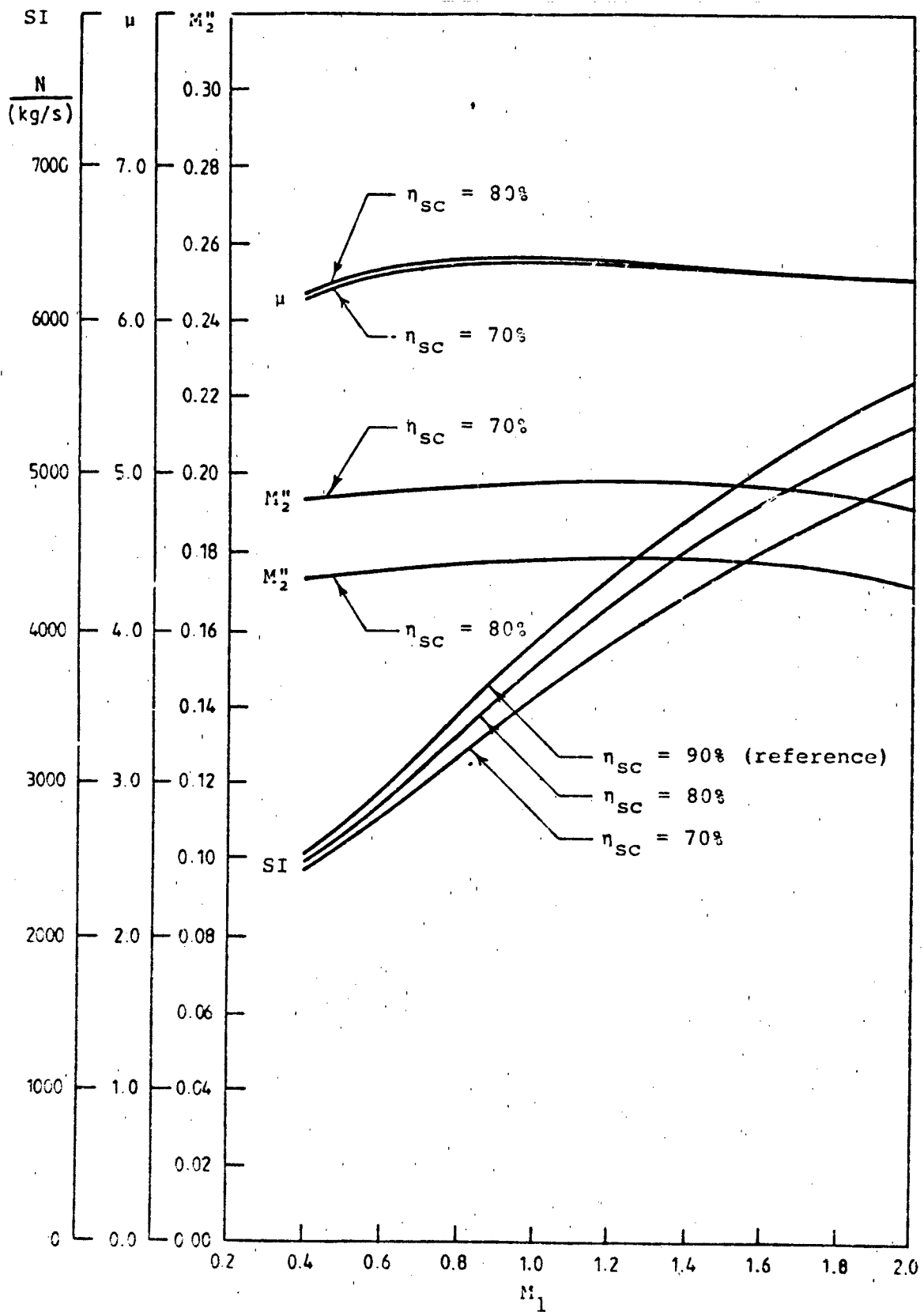

FIG. 7

OPTIMUM VALUES OF SI AND CORRESPONDING VALUES OF  $\mu$  AND  $M_2$  VERSUS  $M_1$  FOR 80% AND 70% SECONDARY COMBUSTION EFFICIENCY.

DISTRIBUTION LIST

AUSTRALIA

DEPARTMENT OF DEFENCE

Defence Central

Chief Defence Scientist )  
Deputy Chief Defence Scientist )  
Superintendent, Science and Technology Programmes ) 1 copy  
Controller, Projects and Analytical Studies )  
Defence Science Representative (UK) (Doc Data Sheet only)  
Counsellor, Defence Science (USA) (Doc Data Sheet only)  
Defence Central Library  
Document Exchange Centre, D.I.S.B. (18 copies)  
Joint Intelligence Organisation  
Librarian H Block, Victoria Barracks, Melbourne  
Director General - Army Development (NSO) (4 copies)

Aeronautical Research Laboratories

Director  
Library  
Superintendent - Aero Propulsion  
Divisional File - Aero Propulsion  
Author: L.P. Erm  
S.A. Fisher  
W.H. Harch

Materials Research Laboratories

Director/Library

Defence Research Centre

Library  
W.H. Jolley  
C. Fong

Navy Office

Navy Scientific Adviser

Army Office

Scientific Adviser - Army  
Engineering Development Establishment, Library

.../cont.

DISTRIBUTION LIST CONTINUED

Air Force Office

Air Force Scientific Adviser  
WEAPENG 2 - AF

Central Studies Establishment

Information Centre

GOVERNMENT AIRCRAFT FACTORIES

Library

SPARES (15 copies)

TOTAL (59 copies)

DOCUMENT CONTROL DATA

1. a. AR No AR-004-011	1. b. Establishment No ARL-AERO-PROP-TM-424	2. Document Date APRIL 1985	3. Task No DST 82/049
4. Title FURTHER DEVELOPMENTS IN A PARAMETRIC STUDY OF RAMROCKET PERFORMANCE		5. Security a. document UNCLASSIFIED	6. No Pages 9
		b. title    c. abstract U            U	7. No Refs 6
8. Author(s)  L.P. ERM		9. Downgrading Instructions  -	
10. Corporate Author and Address  Aeronautical Research Laboratories, P.O., Box 4331, Melbourne, Vic., 3001		11. Authority (as appropriate) a. Sponsor    b. Security    c. Downgrading    d. Approval  -	
12. Secondary Distribution (of this document)  Approved for Public Release  Overseas enquirers outside stated limitations should be referred through ASDIS, Defence Information Services Branch, Department of Defence, Campbell Park, CANBERRA ACT 2601.			
13. a. This document may be ANNOUNCED in catalogues and awareness services available to ...  No limitations			
13. b. Citation for other purposes (ie casual announcement) may be (select) unrestricted (or) as for 13 a.			
14. Descriptors  Ramrockets Parametric analysis Performance		15. COSATI Group  02108	
16. Abstract  The performance of a ramrocket is estimated for a set of reference conditions and then the effect on performance of variable altitude, radial injection of the primary jet, variable intake pressure recovery and different levels of secondary combustion efficiency are each examined in turn. The results are presented graphically in terms of specific impulse.			

This page is to be used to record information which is required by the Establishment for its own use but which will not be added to the DISTIS data base unless specifically requested.

16. Abstract (Contd)		
17. Imprint  Aeronautical Research Laboratories, Melbourne		
18. Document Series and Number  Aero Propulsion Technical Memorandum 424	19. Cost Code  42 3645	20. Type of Report and Period Covered
21. Computer Programs Used		
22. Establishment File Ref(s)		