

AD-A161 961

CORRELATION OF WAVE LOADS PREDICTED BY THE EXTENDED
SHIPMO COMPUTER PROGR (U) DEFENCE RESEARCH
ESTABLISHMENT ATLANTIC DARTMOUTH (NOVA SCOTI S AMDO
AUG 85 DREA-TM-85/218 F/G 11/10

1/1

UNCLASSIFIED

NL

END
FORM
100

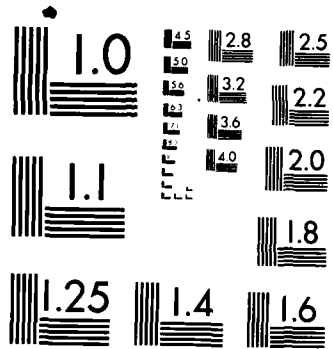

MICROCOPY RESOLUTION TEST CHART
NATIONAL BUREAU OF STANDARDS-1963-A

UNLIMITED DISTRIBUTION

2



National Defence
Research and
Development Branch

Défense Nationale
Bureau de Recherche
et Développement

TECHNICAL MEMORANDUM 85/218
AUGUST 1985

AD-A161 961

CORRELATION OF WAVE LOADS
PREDICTED BY THE EXTENDED
SHIPMO COMPUTER PROGRAM
WITH EXPERIMENTS

S. Ando

DTIC
ELECTE
DEC 06 1985
S D
E

DTIC FILE COPY

Defence
Research
Establishment
Atlantic



Centre de
Recherches pour la
Défense
Atlantique

Canada

This document has been approved
for public release and sale; its
distribution is unlimited.

8 5 1 2 3 1 2 7

DEFENCE RESEARCH ESTABLISHMENT ATLANTIC

9 GROVE STREET

P.O. BOX 1012
DARTMOUTH, N.S.
B2Y 3Z7

TELEPHONE
(902) 426-3100

CENTRE DE RECHERCHES POUR LA DÉFENSE ATLANTIQUE

9 GROVE STREET

C.P. 1012
DARTMOUTH, N.É.
B2Y 3Z7

UNLIMITED DISTRIBUTION



National Defence
Research and
Development Branch

Défense Nationale
Bureau de Recherche
et Développement

CORRELATION OF WAVE LOADS
PREDICTED BY THE EXTENDED
SHIPMO COMPUTER PROGRAM
WITH EXPERIMENTS

S. Ando

AUGUST 1985

Approved by T. Garrett

Director/Technology Division

DISTRIBUTION APPROVED BY

D/TO

TECHNICAL MEMORANDUM 85/218

Defence
Research
Establishment
Atlantic



Centre de
Recherches pour la
Défense
Atlantique

Canada

ABSTRACT

Wave loads predicted by the extended SHIPMO computer program were compared with experimental data in an attempt to assess the range of validity and to estimate the uncertainty of the predictions. In general, the agreement between theory and experiment was good for the vertical bending moment, but fair to poor for the horizontal bending moment. The predicted torsional moment was found to be in gross disagreement with the measured values in terms of both magnitude and trend. It was not possible to find any correlation of the pattern of the discrepancy between theory and experiment with the principal design characteristics, such as hull form or weight distribution. The present comparison shows that the prediction of ship motions in oblique seas needs to be further improved. Also, systematic model tests covering a wide range of the variables are required to assess the uncertainty of the measurement, and hence, to determine the range of confidence of the predicted loads more clearly.

RESUME

On a comparé les charges exercées par les vagues, telles que prévues par le programme informatique augmenté SHIPMO, aux données expérimentales, dans un effort pour évaluer la gamme de validité et estimer l'incertitude des prévisions. En général, l'accord entre la théorie et l'expérience est bon pour le moment fléchissant vertical, mais de passable à médiocre pour le moment horizontal. Le moment de torsion prévu s'écarte beaucoup des mesures, tant en amplitude qu'en direction. On n'a pu établir de corrélation, quant à la tendance des écarts entre la théorie et l'expérience, en ce qui a trait aux caractéristiques principales de conception comme la forme de la coque ou la répartition du poids. La présente comparaison révèle qu'une amélioration des prévisions des mouvements d'un navire qui prend les vagues de côté s'impose. Il faut aussi procéder à des essais systématiques sur maquettes qui portent sur une vaste gamme des variables pour évaluer l'incertitude des mesures et déterminer ainsi avec plus de précision l'intervalle de confiance des charges prévues.

TABLE OF CONTENTS

ABSTRACT	ii
NOTATION	iv
1. INTRODUCTION	1
2. METHOD OF ANALYSIS	1
3. DISCUSSION OF RESULTS	9
4. CONCLUDING REMARKS	11
TABLES	13
FIGURES	19
REFERENCES	32

APPENDIX

Comparison of Predicted and Measured
Motions of Destroyer Models I and II.



Accession For	
NTIS GRA&I	<input checked="" type="checkbox"/>
DTIC TAB	<input type="checkbox"/>
Unannounced	<input type="checkbox"/>
Justification	
By _____	
Distribution/ _____	
Availability Codes	
Dist	Avail and/or Special
A-1	

NOTATION

AP	aft perpendicular
B	beam
C_B	block coefficient, $\nabla/(LBT)$
C_M	bending moment coefficient ($= VBM/\rho gBL^2\alpha$, or $HBM/\rho gBL^2\alpha$)
C_S	shearing force coefficient ($=$ shearing force/ $\rho gBL\alpha$)
C_T	torsional moment coefficient ($=$ torsional moment/ $\rho gBL^2\alpha$)
D_j	hydrodynamic force and moment on portion of hull due to body motion
E_j	exciting force and moment on portion of hull
F_j	external force and moment on portion of hull
F_n	Froude number
FP	forward perpendicular
HBM	horizontal bending moment
I_j	inertia force and moment on portion of hull
L	length between perpendiculars
R_j	restoring force and moment on portion of hull
$Re\{\cdot\}$	real part of $\{\cdot\}$
T	draft
U	speed
V_j	wave load component
V_{j0}	complex amplitude of V_j
V_{jR}	real part of V_{j0}
V_{jI}	imaginary part of V_{j0}
VBM	vertical bending moment
X_j	complex variable for either of V_j , I_j , R_j , E_j , D_j
X_{j0}	complex amplitude of X_j
X_{jR}	real part of X_{j0}
X_{jI}	imaginary part of X_{j0}
a	submerged sectional area
a_{jk}	two-dimensional sectional added mass coefficient
b	sectional beam at waterplane
b_{jk}	two-dimensional sectional damping coefficient
f_j	sectional Froude-Kriloff force

g	acceleration of gravity
h_j	sectional diffraction force
i	$\sqrt{-1}$
i_x	sectional mass moment of inertia about x-axis
j, k	subscripts indicating modes ($j, k = 1, 2, \dots, 6$ refer to surge, sway, heave, roll, pitch and yaw, respectively)
k_w	wave number = ω^2/g
i_x	sectional mass per unit length
om	sectional metacentric height
t	time
x, y, z	coordinate system as defined in Figure 1
z	z-coordinate of sectional centre of gravity
α	wave amplitude
β_s	principal sea direction relative to ship's heading, Figure 3
∇	displacement volume
η_j	motion displacement
$\dot{\eta}_j$	(= $d\eta_j/dt$) velocity
$\ddot{\eta}_j$	(= $d^2\eta_j/dt^2$) acceleration
θ_j	phase angle of wave load
λ	wavelength
ξ	variable of integration in x-direction
ρ	mass density of water
ω	frequency of wave encounter
ω_w	absolute wave frequency.

1. INTRODUCTION

One of DREA's ship dynamics research objectives is to provide the warship designer with analytical "tools" which enable him to estimate the motions and the associated wave loads on ships at sea. Recently, additional subroutines¹ to calculate the wave loads have been developed and integrated into the ship motion computer program SHIPMO². The new subroutines calculate the root-mean-square values of wave loads in five degrees of freedom in irregular short-crested seas as well as the transfer function for wave loads in regular seas.

The purpose of this Technical Memorandum is to report the results of a study which compared the wave loads predicted by the extended version of SHIPMO¹ with those measured in experiments.

The method of analyses of motions and wave loads adopted in SHIPMO is essentially based on the linear strip theory due to Salvesen et al³. However, the coefficients in the equations of lateral anti-symmetric motions, including roll, are modified by taking into account the contribution from the lifting surfaces on the hull (stabilizer fins, bilge keels, rudders, propeller-shaft brackets, etc.), the details of which are found in Reference 4. The summary of the method of analysis of wave loads in regular waves is presented in Section 2.

In Section 3, the predicted wave loads are compared with five sets of published experimental data.

2. METHOD OF ANALYSIS

Figure 1 shows the right-handed moving cartesian coordinate system used for the calculation of wave loads and motions. The origin is located at the equilibrium position of the centre of gravity of the ship. The x-axis points to the bow and the y-axis extends to port, both being parallel to the undisturbed free surface; z is measured vertically upward. The coordinate system maintains a fixed orientation with respect to the undisturbed free surface while it translates with the mean velocity of the ship. The dynamic wave load components acting on a ship cross section are defined in Figure 2.

The sea direction β_s is defined in Figure 3 as the angle between the mean velocity vector of the ship and the principal direction of propagation of the wave train. Thus, $\beta_s = 0^\circ$ for following seas, $\beta_s = 90^\circ$ for beam seas from port, and $\beta_s = 180^\circ$ for head seas.

2.1 Wave Loads in Regular Waves

Consider a ship moving in a train of long-crested, or unidirectional regular waves of a particular absolute frequency, ω_w , on a straight course at a fixed orientation, β_s , to the direction of the waves' advance.

Due to its forward motion, the ship encounters the waves with a frequency of encounter ω which is related to the absolute wave frequency ω_w via:

$$\omega = \omega_w - k_w U \cos \beta_s \quad (1)$$

where $k_w = \text{wave number} = \omega_w^2/g$

$U = \text{ship speed}$

$\beta_s = \text{sea direction}$

The resulting wave loads as well as motions will then be harmonic functions of time with the frequency given by Equation (1), and having a solution of the form:

$$X_j(t) = X_{j0} \exp(i\omega t) = (X_{jR} + iX_{jI}) \exp(i\omega t) \quad (2)$$

where $X_j = \text{complex variable indicating formal solution for the motion or load in the } j\text{th mode}$

$X_{j0} = \text{complex amplitude of } X_j$

$X_{jR}, X_{jI} = \text{real and imaginary parts of } X_{j0}, \text{ respectively}$

$i = \sqrt{-1}$

$\omega = \text{frequency of wave encounter}$

$t = \text{time}$

In order to facilitate the algebraic work, the computation is performed in the complex field.

In expressions involving complex numbers, only the real parts are physically realizable; thus,

$$\begin{aligned} \text{Re}\{X_j(t)\} &= X_{jR} \cos \omega t - X_{jI} \sin \omega t \\ &= |X_{j0}| \cos(\omega t + \theta_j) \end{aligned} \quad (3)$$

where $\text{Re}\{X_j(t)\}$ = real part of X_j
 $|X_{j0}| = (X_{jR}^2 + X_{jI}^2)^{1/2}$ = amplitude
 $\theta_j = \arctan(X_{jI}/X_{jR})$ = phase angle

The total force acting on a cross section of a ship's hull may be divided into two components: inertial force and external force. Since inertial forces, the magnitude of which are equal to the mass times acceleration, act in the directions opposite to those of the external forces, the net loading per unit length of a ship's hull is equal to the difference between these two forces:

$$dV_j/d\xi = dI_j/d\xi - dF_j/d\xi \quad (4)$$

where $dV_j/d\xi$ = net load in j th mode per unit length,
 $I_j/d\xi$ = local inertial force in j th mode per unit length,
 $dF_j/d\xi$ = local external force in j th mode per unit length.

The modes j of the loading are defined as follows:

$j = 1$ axial force
 $j = 2$ horizontal shearing force
 $j = 3$ vertical shearing force
 $j = 4$ torsional moment
 $j = 5$ vertical bending moment
 $j = 6$ horizontal bending moment

The net wave loads*, V_j , acting on an arbitrary cross section are obtained by integrating the load per unit length of Equation (4) from one end of the hull to the specified cross section.

Thus $V_j = \int (dV_j/d\xi) d\xi$ = net wave load
 $I_j = \int (dI_j/d\xi) d\xi$ = inertial forces and moments
 $F_j = \int (dF_j/d\xi) d\xi$ = external forces and moments

Hence, from equation (1)

$$V_j = I_j - F_j \quad (j = 1, \dots, 6) \quad (5)$$

* When the motion of an entire ship is considered, the external forces are exactly balanced by the inertia forces, so that the sum of all forces acting on the ship is zero. However, the two kinds of forces acting on an elemental section of the hull are generally not balanced.

It can therefore be seen that in order to determine the wave loads at a particular cross section, the forces and torsional moments acting over the portion of the hull lying on one side of the cross section in question must be known a priori, and that unlike the calculation of motions, in which a set of equations must be solved simultaneously, the calculation of wave loads on a cross section consists simply of the summation of the predetermined forces and torsional moments acting on one side of the section. The choice of the side in any case is of course arbitrary. In the subprograms, the summation is performed over the hull forward of the cross section under consideration.

The axial force ($j = 1$), the force acting in the direction of the x-axis, is assumed negligible³ and is not considered herein.

The method of analysis adopted in the subprograms is the stripwise computational technique of Salvesen et al³. The forces and moments acting on cross sections are derived in terms of motions (displacement, velocities, and accelerations) and hydrodynamic coefficients such as added-mass, added moment of inertia, and damping coefficients. The data that are extraneous to the calculation of motions, but required for the wave load calculation, are section masses, sectional radii of gyration for roll, and positions of sectional centres of gravity.

Outlined below is the computational technique implemented in the subprograms.

The hull is divided into a number of equally spaced ordinate stations, with No. 0 station at the forward perpendicular (FP). The total number of stations may be up to 21. Each hull section, or "strip", spans two consecutive half-stations and is considered to be a cylinder with a constant cross section identical to that of the integral station at its longitudinal midpoint. The extreme fore and aft strips, which span the integral stations at the perpendiculars and the adjacent half-stations, have cross sections identical to those at the perpendiculars.

For the purpose of wave load calculation, the following assumptions are made:

- (i) that the ship is a rigid body;
- (ii) that the external forces and moments acting on each strip as well as the mass of the strip are concentrated in the plane of the integral station contained in the strip.

The external forces and moments are caused by the water exerting forces on the hull, and consist of three components: hydrostatic restoring forces and moments due to the displacement of the rigid hull from the equilibrium position, exciting forces and moments due to the oncoming waves, and the hydrodynamic forces and moments due to the ship's motion. Hence,

$$F_j = R_j + E_j + D_j \quad (j = 2, \dots, 6) \quad (6)$$

where R_j = hydrostatic restoring forces and moments

E_j = exciting forces and moments

D_j = hydrodynamic forces and moments due to ship motions

From Equations (5) and (6), the wave load in the j th mode on a cross section can be expressed as:

$$V_j = I_j - R_j - E_j - D_j \quad (j = 2, \dots, 6) \quad (7)$$

The following expressions for the I_j , R_j , E_j and D_j are given in Reference 3, to which the reader is referred for a detailed derivation. Note that all of the integrations indicated are over the length of the hull forward of the specified cross section.

The inertial forces and moments are given by:

$$I_2 = \int m(\ddot{\eta}_2 + \xi \ddot{\eta}_6 - \bar{z} \ddot{\eta}_4) d\xi \quad (8)$$

$$I_3 = \int m(\ddot{\eta}_3 - \xi \ddot{\eta}_5) d\xi \quad (9)$$

$$I_4 = \int \{ i_x \ddot{\eta}_4 - m \bar{z} (\ddot{\eta}_2 + \xi \ddot{\eta}_6) \} d\xi \quad (10)$$

$$I_5 = - \int m(\xi - x)(\ddot{\eta}_3 - \xi \ddot{\eta}_5) d\xi \quad (11)$$

$$I_6 = \int m(\xi - x)(\ddot{\eta}_2 + \xi \ddot{\eta}_6 - \bar{z} \ddot{\eta}_4) d\xi \quad (12)$$

where i_x = sectional moment of inertia about the x-axis

m = sectional mass per unit length

x = x-coordinate of the cross section

\bar{z} = z-coordinate of the sectional centre of gravity

ξ = integration variable

$\ddot{\eta}_j$ = acceleration

The hydrostatic restoring forces and moments are given by:

$$R_3 = -\rho g f b (\eta_3 - \xi \eta_5) d\xi \quad (13)$$

$$R_4 = g \eta_4 \int (\rho a \overline{om} - m \bar{z}) d\xi \quad (14)$$

$$R_5 = \rho g f b (\xi - x) (\eta_3 - \xi \eta_5) d\xi \quad (15)$$

with $R_2 = 0$ and $R_6 = 0$.

Here

- a = submerged sectional area
- b = sectional beam at waterplane
- g = acceleration of gravity
- \overline{om} = sectional metacentric height
- η_j = motion displacement
- ρ = mass density of water

The exciting forces and moments due to the oncoming regular waves are given by:

$$E_j = \rho \alpha \left\{ \int (f_j + h_j) d\xi + \frac{U}{i\omega} h_j(x) \right\} e^{i\omega t} \quad j=2,3,4 \quad (16)$$

$$E_5 = -\rho \alpha \left\{ \int [(\xi - x)(f_3 + h_3) + \frac{U}{i\omega} h_3] d\xi \right\} e^{i\omega t} \quad (17)$$

$$E_6 = \rho \alpha \left\{ \int [(\xi - x)(f_2 + h_2) + \frac{U}{i\omega} h_2] d\xi \right\} e^{i\omega t} \quad (18)$$

where

- U = mean speed of ship
- f_j = Froude-Kriloff force (see Equation (49) of Ref. 2)
- h_j = diffraction force (see Equation (50) of Ref. 2)
- α = wave amplitude

The hydrodynamic forces and moments due to ship motions are given by:

$$\begin{aligned}
 D_2 = & - \int \{ a_{22}(\ddot{\eta}_2 + \xi \dot{\eta}_6) + b_{22}(\dot{\eta}_2 + \xi \dot{\eta}_6) \\
 & + a_{24} \ddot{\eta}_4 + b_{24} \dot{\eta}_4 + \frac{U}{\omega^2} b_{22} \ddot{\eta}_6 - U a_{22} \dot{\eta}_6 \} d\xi \\
 & - [U a_{22}(\dot{\eta}_2 + \xi \dot{\eta}_6) - \frac{U}{\omega^2} b_{22}(\ddot{\eta}_2 + \xi \ddot{\eta}_6) \\
 & + \frac{U^2}{\omega^2}(a_{22} \ddot{\eta}_6 + b_{22} \dot{\eta}_6) + U(a_{24} \dot{\eta}_4 - \frac{1}{\omega^2} b_{24} \ddot{\eta}_4)] \xi = x \quad (19)
 \end{aligned}$$

$$\begin{aligned}
 D_3 = & - \int \{ a_{33}(\ddot{\eta}_3 - \xi \dot{\eta}_5) + b_{33}(\dot{\eta}_3 - \xi \dot{\eta}_5) \\
 & - \frac{U}{\omega^2} b_{33} \ddot{\eta}_5 + U a_{33} \dot{\eta}_5 \} d\xi - [U a_{33}(\dot{\eta}_3 - \xi \dot{\eta}_5) \\
 & - \frac{U}{\omega^2} b_{33}(\ddot{\eta}_3 - \xi \ddot{\eta}_5) - \frac{U^2}{\omega^2}(a_{33} \ddot{\eta}_5 + b_{33} \dot{\eta}_5)] \xi = x \quad (20)
 \end{aligned}$$

$$\begin{aligned}
 D_4 = & - \int \{ a_{44} \ddot{\eta}_4 + (b_{44} + b_{44}^*) \dot{\eta}_4 + a_{24}(\ddot{\eta}_2 + \xi \ddot{\eta}_6) \\
 & + b_{24}(\dot{\eta}_2 + \xi \dot{\eta}_6) + \frac{U}{\omega^2} b_{24} \ddot{\eta}_6 - U a_{24} \dot{\eta}_6 \} d\xi \\
 & - [U a_{24}(\dot{\eta}_2 + \xi \dot{\eta}_6) - \frac{U}{\omega^2} b_{24}(\ddot{\eta}_2 + \xi \ddot{\eta}_6) \\
 & + \frac{U^2}{\omega^2}(a_{24} \ddot{\eta}_6 + b_{24} \dot{\eta}_6) + U(a_{44} \dot{\eta}_4 - \frac{1}{\omega^2} b_{44} \ddot{\eta}_4)] \xi = x \quad (21)
 \end{aligned}$$

$$\begin{aligned}
D_5 = & \int (\xi - x) \{ a_{33}(\ddot{\eta}_3 - \xi \ddot{\eta}_5) + b_{33}(\dot{\eta}_3 - \xi \dot{\eta}_5) \} d\xi \\
& + \int \{ U a_{33}(\dot{\eta}_3 - x \dot{\eta}_5) - \frac{U}{\omega^2} b_{33}(\ddot{\eta}_3 - x \ddot{\eta}_5) \\
& - \frac{U^2}{\omega^2} (a_{33} \ddot{\eta}_5 + b_{33} \dot{\eta}_5) \} d\xi \quad (22)
\end{aligned}$$

$$\begin{aligned}
D_6 = & -\int (\xi - x) \{ a_{22}(\ddot{\eta}_2 + \xi \ddot{\eta}_6) + b_{22}(\dot{\eta}_2 + \xi \dot{\eta}_6) \\
& + a_{24} \ddot{\eta}_4 + b_{24} \dot{\eta}_4 \} d\xi - \int \{ U a_{22}(\dot{\eta}_2 + x \dot{\eta}_6) \\
& - \frac{U}{\omega^2} b_{22}(\ddot{\eta}_2 + x \ddot{\eta}_6) + \frac{U^2}{\omega^2} (a_{22} \ddot{\eta}_6 + b_{22} \dot{\eta}_6) \\
& + U a_{24} \dot{\eta}_4 - \frac{U}{\omega^2} b_{24} \ddot{\eta}_4 \} d\xi \quad (23)
\end{aligned}$$

- where
- a_{jk} = two-dimensional sectional added mass coefficient
 - b_{jk} = two-dimensional sectional damping coefficient
 - b_{44}^* = two dimensional sectional viscous damping coefficient for roll
 - $\dot{\eta}_j$ = velocity

3. DISCUSSION OF RESULTS

Table 1 summarizes the cases examined in the correlation study. In the following discussion, only the minimum proportion of the results necessary to illustrate the overall correlation characteristics are presented.

Principal particulars for the five model ships shown in Table 1 are given in Table 2. In fact, some of the dimensions given are for ship scale, like the SHIPMO input, so that SHIPMO computed results would correspond to published experimental ones. The reason for the apparent inconsistency in the choice of the variables for the abscissas and ordinates in Figures 4 through 8 is to preserve the original formats in which the experimental results are presented in the References, and hence to facilitate the correlation of the predicted and experimental results.

Firstly, the predicted moment and shearing force coefficients for Destroyer Model I^{5*} are compared with the experimental results in Figure 4. Agreement between the predicted and measured vertical bending moments (VBM) at stations 5, 10 and 13 is good in head seas (Figure 4a), but poor in following seas (Figure 4b). The predicted VBM for this model tended to overestimate the experimental results. Note in Figure 4a that the magnitudes of the experimental variations between the pairs of measurements at $\lambda/L = 0.6$ for stations 10 and 13, at $\lambda/L = 1.2$ for station 5, and at $\lambda/L = 1.5$ for station 10, range from approximately 30 to 100% of the lower values.

The predicted VBM at midships in oblique seas are compared with experiments in Figure 4c. Correlation is somewhat better for quartering seas than for bow seas.

Figures 4d and 4e show fair agreement between the predicted and measured horizontal bending moments (HBM). Though the maximum HBM are not clearly defined by the experiments, the theory tends to underestimate the experimental results. This trend is opposite to that observed for the VBM. Incidentally, it will be noted in Figure 4d that the predicted maximum HBM occurs in waves whose so-called effective wavelength - defined as the wavelength multiplied by the absolute value of secant of the wave direction - is approximately equal to L.

* The numbering of ordinate stations in Reference 5 is slightly different from that adopted in SHIPMO in that the station at the forward perpendicular (FP) is numbered 1 in the former, while it is to be numbered 0 in the latter. The numbering of ordinate stations in this memorandum conforms to that of SHIPMO. Thus, station 5 is situated at L/4 from the FP, where L is the length between perpendiculars, and station 10 at midship, etc. Incidentally, Reference 5 contains the most comprehensive model test data for wave loads presently available in the open literature.

The predicted and measured torsional moments show gross discrepancies in Figures 4f and 4g. Further work is clearly needed to resolve these. (Note, the scale division of the ordinate in Figures 4f and 4g is 100 times smaller than in Figures 4a through 4e.)

The comparison of the predicted vertical shears with experiments in head seas is shown in Figure 4h. The predicted and measured maxima appear to be of the same order of magnitude for station 5, where shear is expected to be greatest. The scatter of the experimental data is particularly evident in this figure.

Next, Figure 5 shows the comparison of the predicted and measured VBM coefficients at midships (station 10) and L/10 abaft midships (station 12), for Destroyer Model II^{6*} in head seas. (Note the experimental results are presented by the solid lines from Reference 6 rather than points.) The predicted maximum VBMs are seen to be consistently 30 to 40% greater than the measured maxima over the Froude number (F_n) range from 0 to 0.40. The good agreement shown in Figure 5b for station 10 appears to be fortuitous judging from the trends in the other figures for different values of F_n .

Thirdly, the predicted VBM and HBM coefficients at midships of a T-2tanker model^{7,10} are compared with experiments in Figure 6. Overall, the predicted VBM shows a good correlation with experiments, though the discrepancy seen in Figure 6c is appreciable. On the other hand, predicted HBM correlates poorly with experiment; the theory tends to underestimate the experimental results considerably, and the discrepancy increases with increasing ship speed. A "weather" HBM causes the bow and stern to deflect toward the oncoming waves; a "leeward" HBM produces deflections in the opposite direction. The analysis, of course, does not differentiate the two, because the ship is assumed to be executing the simple harmonic oscillatory motions, linear and angular, about the translating axes.

The fourth case in Figure 7 shows the comparison between the predicted and measured VBM and HBM coefficients at midships of the Series 60 ($C_B = 0.80$) hull^{8,10}. The agreement between the predicted and measured VBM appears to be good in nearly head seas, but poor in other wave directions (Figure 7a). The tendency of theory to underestimate experimental results in Figure 7a is more conspicuous in Figure 7b, in which the predicted HBM is shown to be consistently less than the experimental results in all wave direction.

* In Reference 6, ordinate stations are numbered from the aft perpendicular, AP (station 0) to the forward perpendicular, FP (station 10) with half-stations between integral stations. The station numbers cited above correspond to the numbering system of SHIPMO; so station 0 is the FP, and station 20 the AP.

Finally, the predicted ratios of VBM and HBM to the wave amplitude at midships of a cargo ship, the WOLVERINE STATE^{9,10}, are compared with experimental data in Figure 8. The agreement between the predicted and measured VBM results is generally good in head seas, but becomes poor in other wave directions (Figures 8a and 8b). As seen in Figures 8c and 8d, the predicted HBM results correlate poorly with the experiments.

Because wave loads on ships are derived as a function of the ship's motions (displacement, velocity and acceleration) and the hydrodynamic coefficients (added mass, added moment of inertia, and damping), the predicted wave loads will at best be only as reliable as these variables; but when compounded, even relatively minor inaccuracies in hydrodynamic coefficients and motions tend to be amplified and result in a significant inaccuracy in the predicted loads. Comparison of the trends of the correlations of wave loads (Figures 4 and 5) and of motions* (Figures A1 and A2 in the appendix†) pertaining to the two destroyer models bears out this fact.

The results of the present comparison show varied degrees of agreement between theory and experiment. Granted that, considering the complexity of the model tests, it will be prudent to make a due allowance for the accuracy of the experimental data when assessing the reliability of the theoretical prediction; yet, in view of the wide margins between the predicted wave loads and the experimental results shown in the present comparisons, the need for further improvement of the theory is evident.

4. CONCLUDING REMARKS

1. The purpose of the present study was to obtain information about the accuracy of the predicted wave loads from the extended SHIPMO computer program, and hence to determine its usefulness as a working tool for ship structural design. The wave loads for five ships in regular waves were calculated by SHIPMO and compared with the experimental data. The main results were as follows:

- (a) The agreement between the predicted and experimental results was generally good for the vertical bending moment in head seas, but the correlation became less satisfactory for oblique and following seas.

* Even though phase angles of ship motions do not appear explicitly in the equations for wave loads given in Section 2 owing to the fact that motions are expressed in terms of complex variables, their accuracy is equally important as that of the motion amplitudes in the wave-load prediction.

† For a comprehensive correlation study of the predicted ship motion with experimental results, see Reference 11.

- (b) The predicted horizontal bending moments were at best in fair agreement with experiment.
- (c) The predicted and experimental results showed glaring discrepancies with respect to the torsional moment.
- (d) There appeared to be no regularity in the pattern of discrepancy between theory and experiment.

No definite assessment could be made about shears because of lack of the relevant experimental data.

2. It was encouraging that the predicted maximum vertical moment in head seas was for the most part in satisfactory agreement with experimental data. However, for the ultimate statistical prediction of the loads in realistic short-crested waves, the accurate predictions of the loads in other headings are equally essential. Thus, the correlation between theory and experiment for the loads in oblique waves would have to be further improved, before the wave loads predicted by SHIPMO could be used with confidence for structural design purposes.

3. The present comparison illustrates the need for systematic model tests with adequate descriptions of the uncertainties in the measurements. The published reports lacked this information. Consequently, it was not possible to clearly define the range of confidence of the predicted wave loads.

TABLE 1: SUMMARY OF CASES EXAMINED IN PRESENT STUDY

<u>Model</u>	<u>Reference</u>	<u>Froude Number</u>	<u>Heading</u>	<u>Range of Wave Characteristics</u>
Destroyer I	(5)	0.21,0.29	0, 30 60, 90 120,150 180	$0.2 < \lambda/L$ 2.2
Destroyer II	(6)	0, 0.075 0.15,0.20 0.30,0.40	180	$1.0 < \omega\sqrt{L/g}$ <4.0
T-2 Tanker	(7,10)	0 ~ 0.20	45,120 135,150 180	$\lambda/L = 1$
Series 60 $C_B = 0.80$	(8,10)	0.15	10, 40 60, 90 120,150 170	$0 < \omega\sqrt{L/g}$ <4.5
WOLVERINE STATE	(9,10)	0.160,0.214	0, 30 60, 90 120,150 180	$0 < \lambda/L$ <1.8

TABLE 2: PRINCIPAL PARTICULARS OF MODELS

<u>Model</u>	<u>Destroyer I</u>	<u>Destroyer II</u>	<u>T-2 Tanker</u>	<u>Series 60</u> <u>$C_B=0.80$</u>	<u>Wolverine</u> <u>State</u>
Reference	5	6	7, 10	8, 10	9, 10
Scale	model	model	model	ship	ship
L, m	5.16	4.88	4.80	193.0	151.0
B, m	0.654	0.573	0.648	27.57	21.79
T, m	0.204	0.185	0.286	11.03	9.14
L/B	7.89	8.52	7.41	7.00	6.93
B/T	3.21	3.10	2.27	2.50	2.38
C_B	0.572	0.490	0.740	0.800	0.655

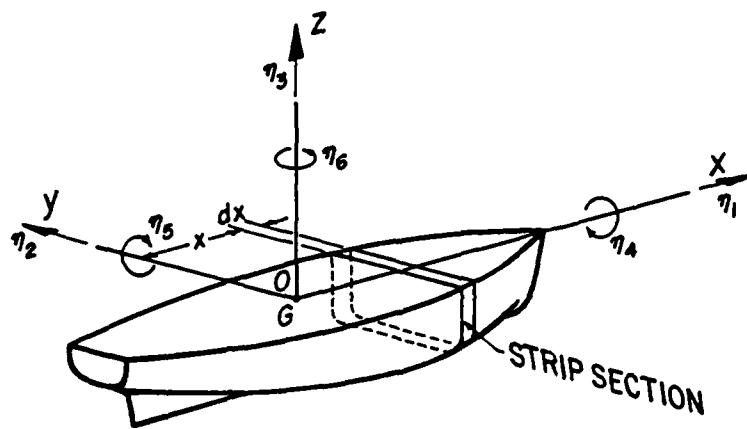

η_1 = SURGE	η_3 = HEAVE	η_5 = PITCH
η_2 = SWAY	η_4 = ROLL	η_6 = YAW

Figure 1 Definition of motions

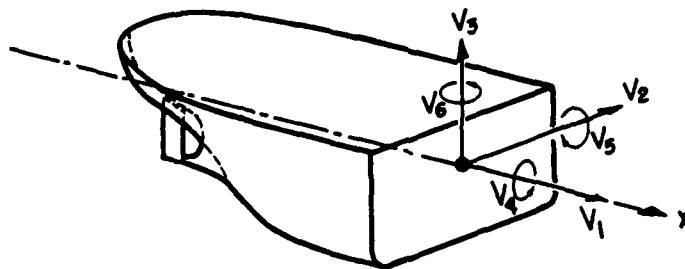

V_1 = COMPRESSION FORCE	V_4 = TORSIONAL MOMENT
V_2 = HORIZONTAL SHEAR FORCE	V_5 = VERTICAL BENDING MOMENT
V_3 = VERTICAL SHEAR FORCE	V_6 = HORIZONTAL BENDING MOMENT

Figure 2 Definition of positive loads

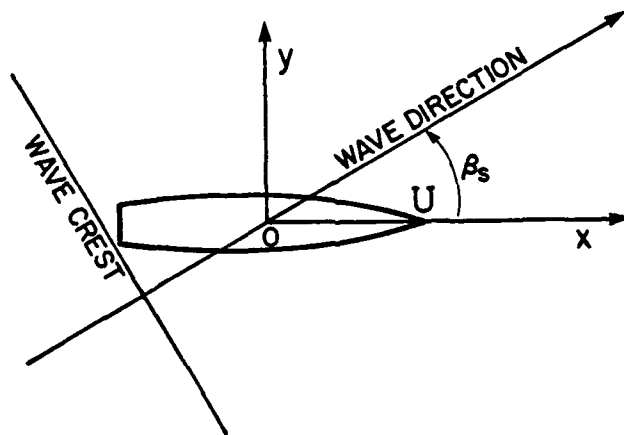
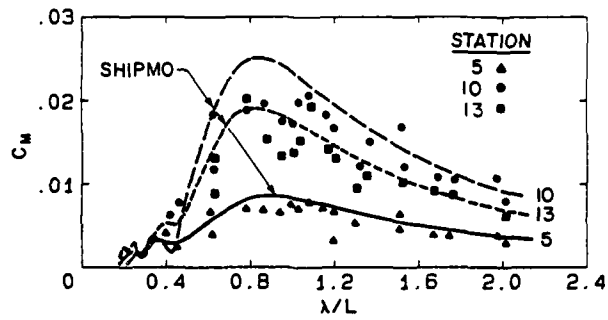
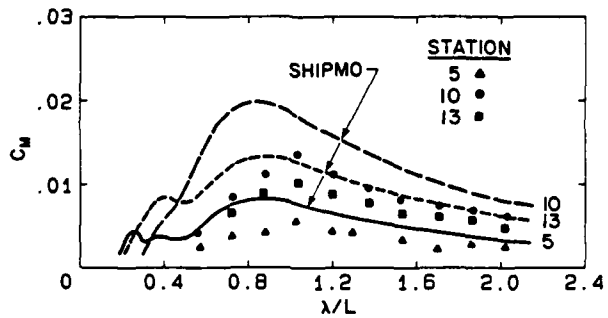

Figure 3 Definition of Sea Direction



(a) Vertical Bending Moment Coefficient in Head Seas ($\beta_S = 180^\circ$)



(b) Vertical Bending Moment Coefficient in Following Seas ($\beta_S = 0^\circ$)

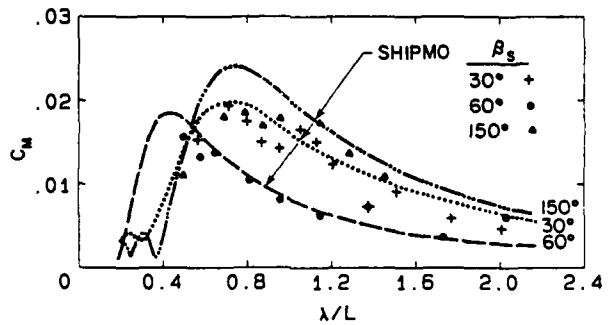

(c) Vertical Bending Moment Coefficient in Midships (Station 10)

Figure 4 Wave Loads on Destroyer Model I ($F_n = 0.21$)

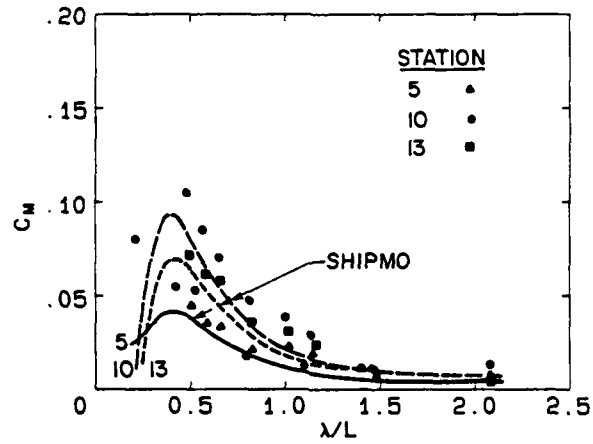

(d) Horizontal Bending Moment Coefficient in Bow Seas ($\beta_S = 120^\circ$)

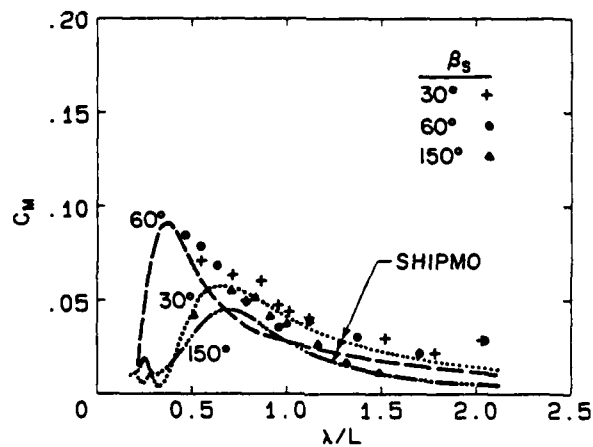

(e) Horizontal Bending Moment Coefficient in Midships (Station 10)

Figure 4 cont'd

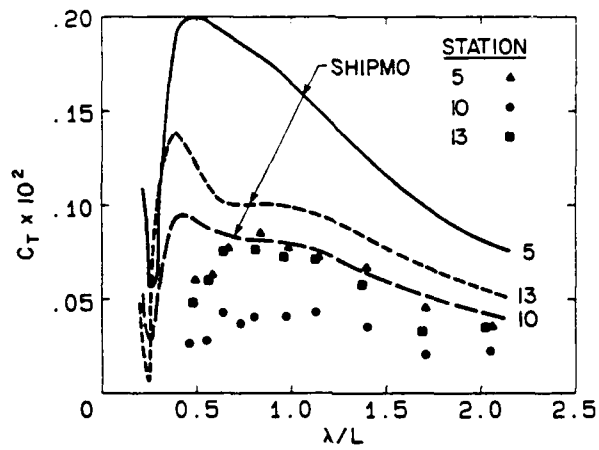

(f) Torsional Moment Coefficient in Quartering Seas ($\beta_s = 60^\circ$)

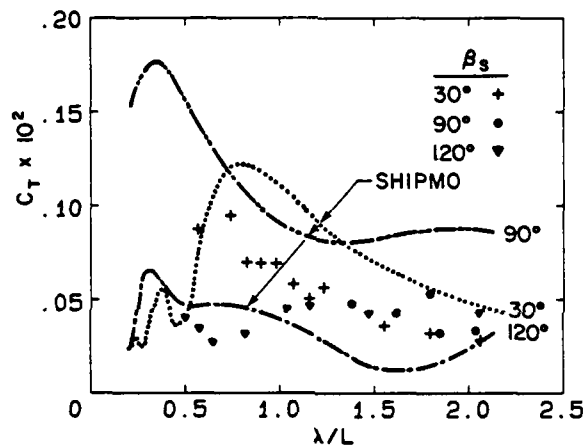

(g) Torsional Moment Coefficient at Midships (Station 10)

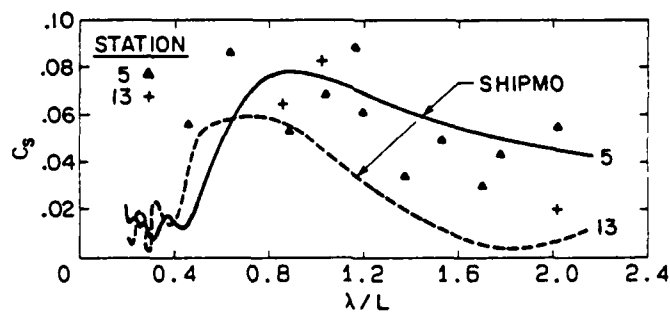

(h) Vertical Shearing Force Coefficient in Head Seas ($\beta_s = 180^\circ$)

Figure 4 cont'd

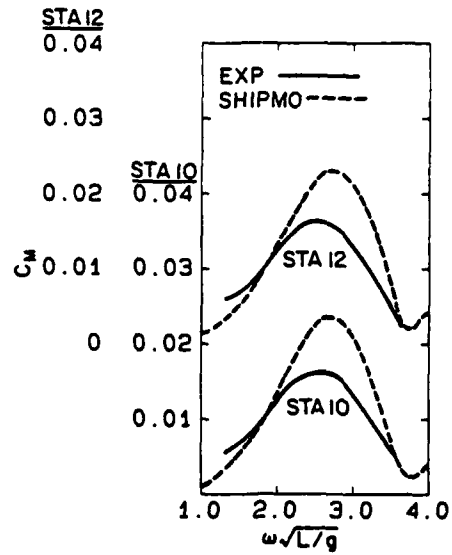

(a) Vertical Bending Moment Coefficient in Head Seas $F_n = 0$

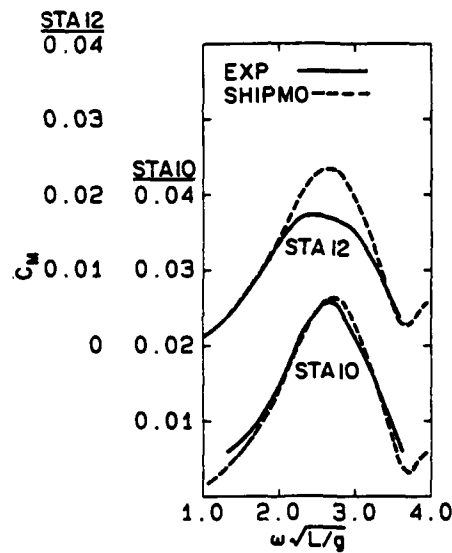

(b) Vertical Bending Moment Coefficient in Head Seas $F_n = 0.15$

Figure 5 Wave Loads on Destroyer Model II

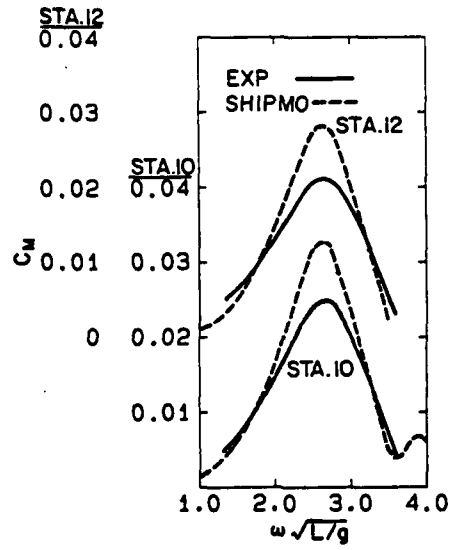

(c) Vertical Bending Moment Coefficient in Head Seas $F_n = 0.30$

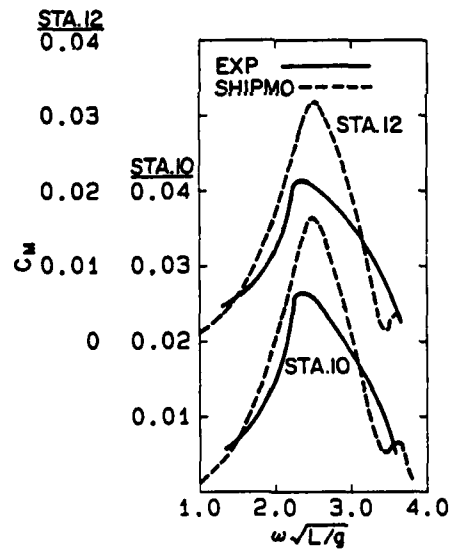

(d) Vertical Bending Moment Coefficient in Head Seas $F_n = 0.40$

Figure 5 cont'd

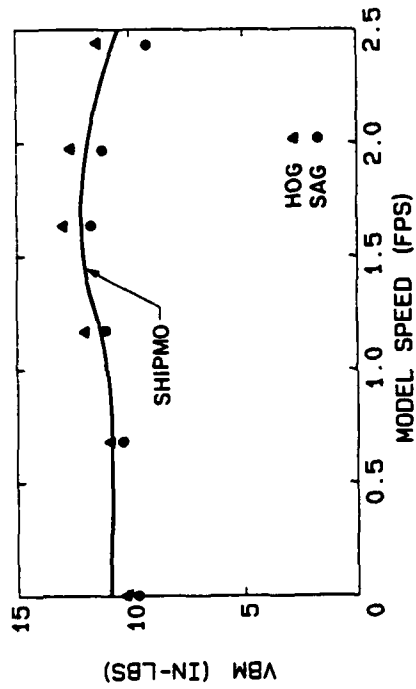

(a) Vertical Bending Moment in Head Seas (Heading = 180°)
Wave Length = Model Length

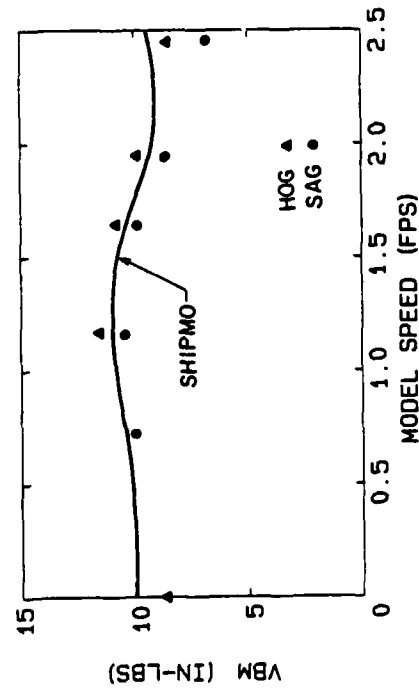

(b) Vertical and Horizontal Bending Moments in Bow Seas (Heading = 150°)
Effective Wave Length - Model Length

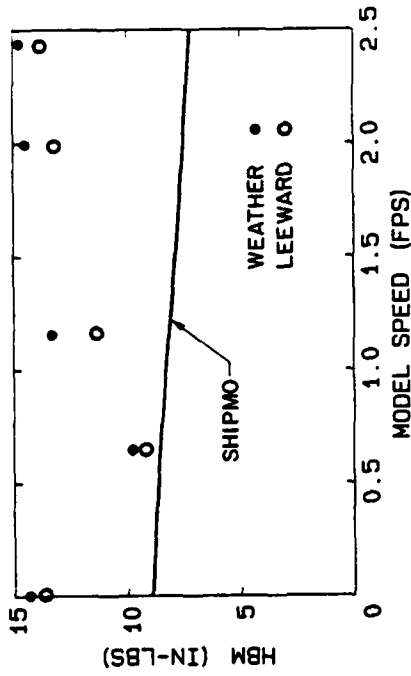
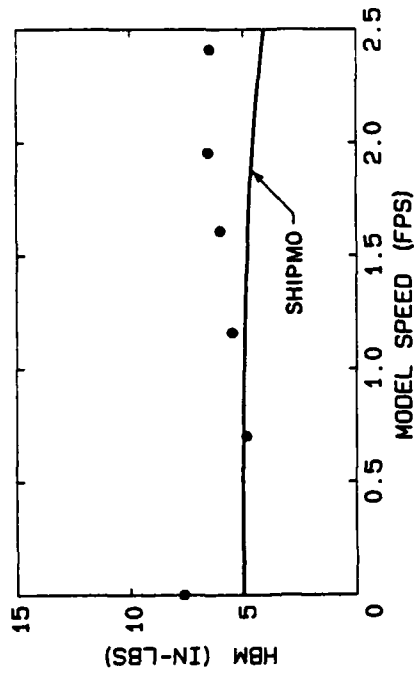
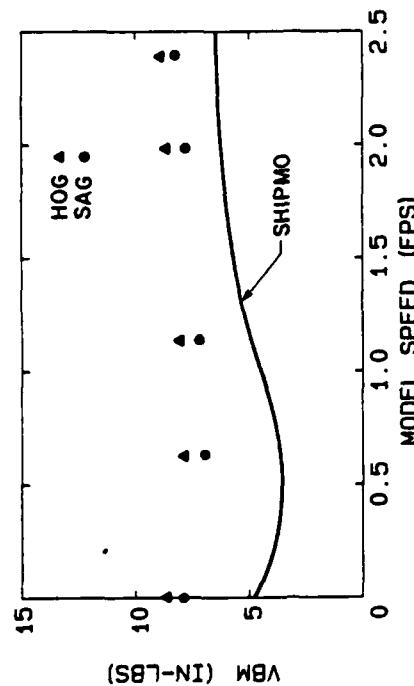

Figure 6 Wave Loads at Midships of a T-2 Tanker Model



(c) Vertical and Horizontal Bending Moments in Bow Seas (Heading = 120°)
Effective Wave Length = Model Length



(d) Vertical and Horizontal Bending Moments in Quartering Seas (Heading = 45°)
Effective Wave Length = Model Length

Figure 6 cont'd

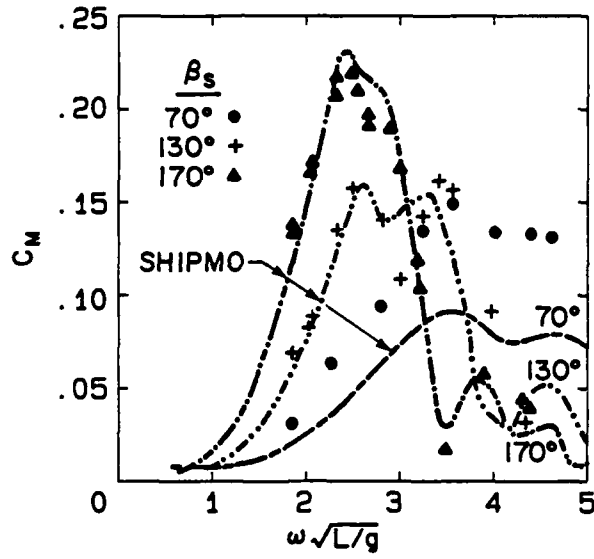

(a) Vertical Bending Moment Coefficient at Midships

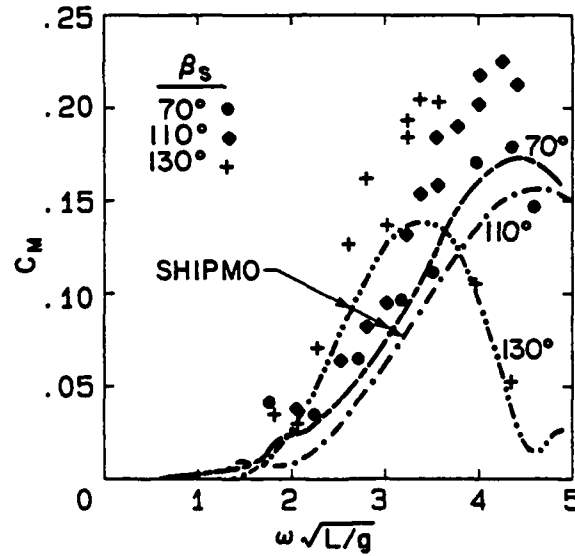

(b) Horizontal Bending Moment Coefficient at Midships

Figure 7 Wave Load on the Series 60 ($C_B = 80$) Hull
($F_n = 0.15$)

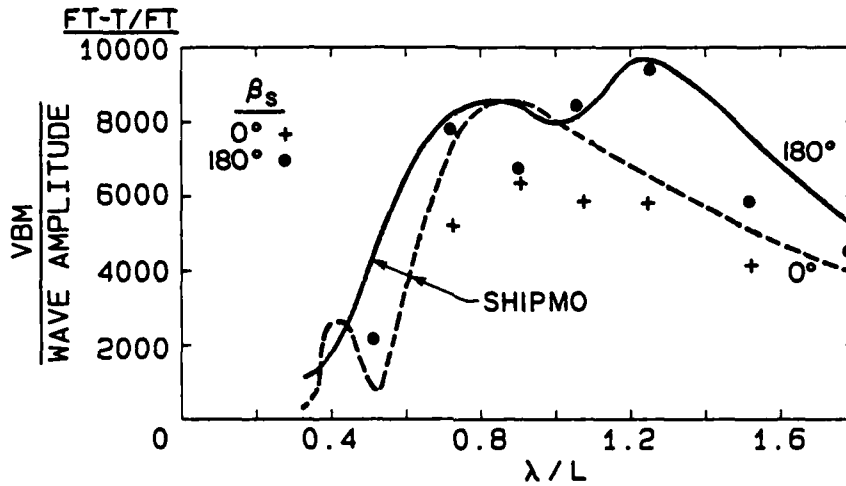

(a) Vertical Bending Moment at Midships in Head and Following Seas

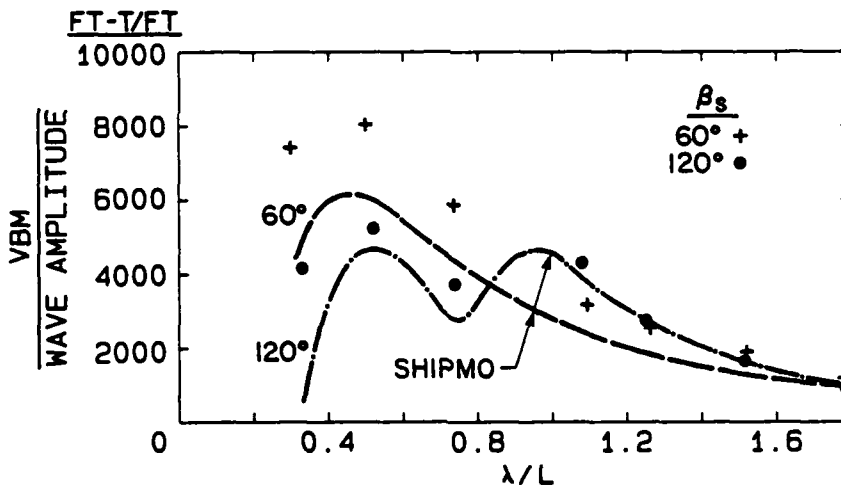

(b) Vertical Bending Moment at Midships in Bow and Quartering seas

Figure 8 Wave Loads on the Cargo Ship "WOLVERINE STATE"
($F_n = 0.214$)

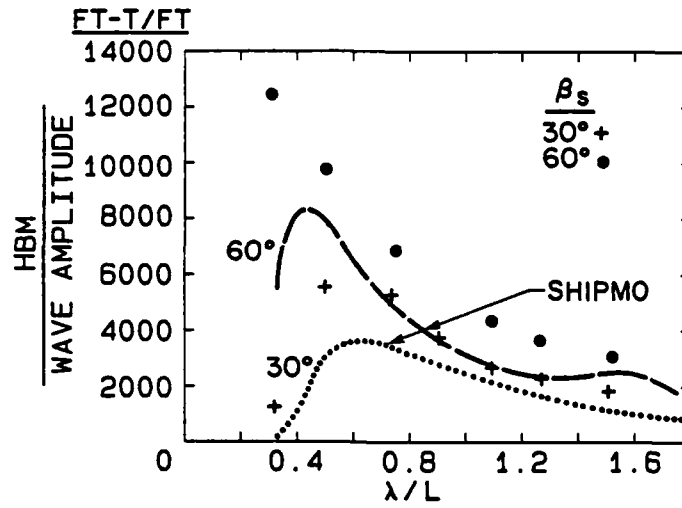

(c) Horizontal Bending Moment at Midships in Bow Seas

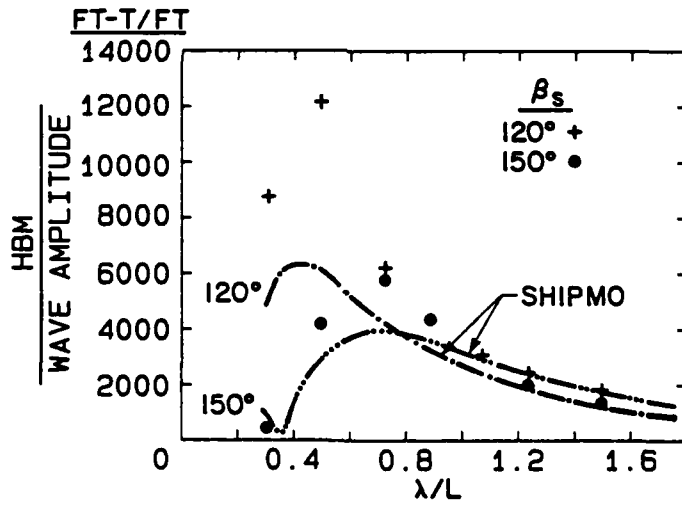

(d) Horizontal Bending Moment at Midships in Quartering Seas

Figure 8 cont'd

APPENDIX

COMPARISON OF THE PREDICTED AND MEASURED MOTIONS OF DESTROYER MODELS I AND II

The non-dimensionalized motions of destroyer model I predicted by the SHIPMO computer program are compared with experimental results in Figure A1 for $F_n = 0.21$. The results for $F_n = 0.29$ were similar in terms of both magnitude and trend. In Figure A1a, the predicted pitch shows a good correlation with experiments in all headings, though theory tends to underestimate the measured responses. The correlation of the predicted heave motion with experimental results is reasonable for head seas, but somewhat poor in oblique waves; particularly in beam waves, the discrepancy between computation and experiment is significant (Figure A1b). The correlation between predicted roll and yaw with experimental data are reasonably good in all headings with the exception at 60° as seen in Figures A1c and d. In general, the correlation between the predicted and experimental results is poor at long wavelengths.

Figure A2 shows the comparison of the predicted non-dimensionalized heave and pitch motions of destroyer model II in head seas with experiment. The results are indicated by solid lines as done in Reference 6. Except for low and high frequency tails, the correlation between the predicted and experimental results is reasonably good over the F_n range 0 to 0.40.

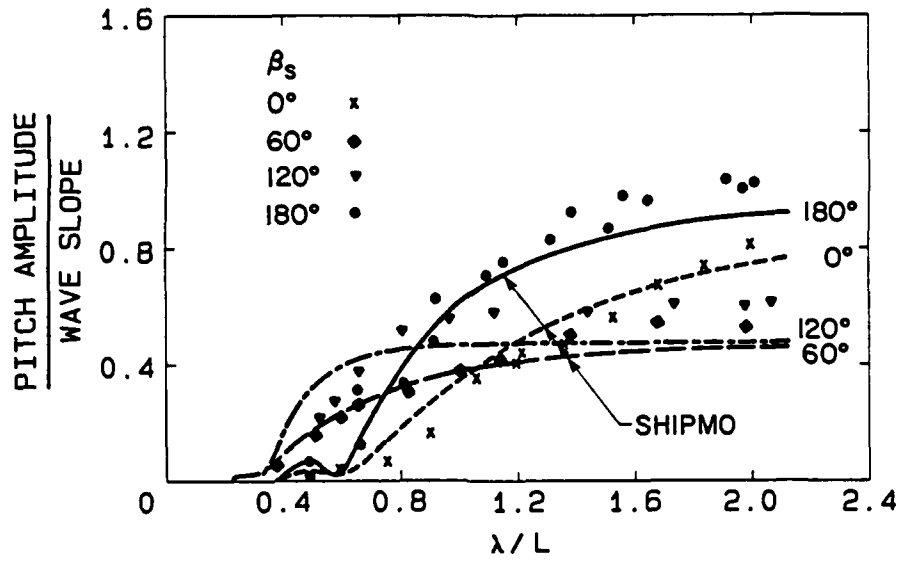

(a) Pitch

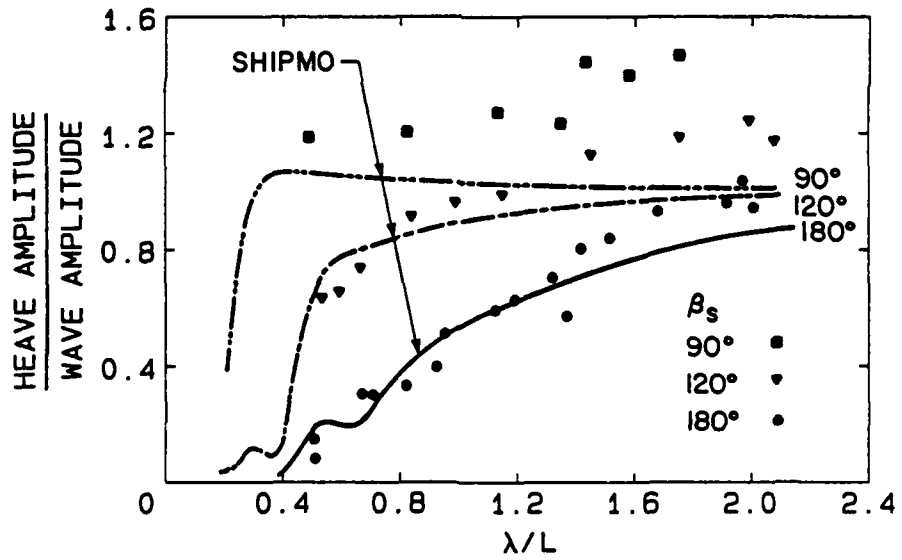

(b) Heave

Figure A.1 Motions of Destroyer Model I in Regular Waves
($F_n = 0.21$)

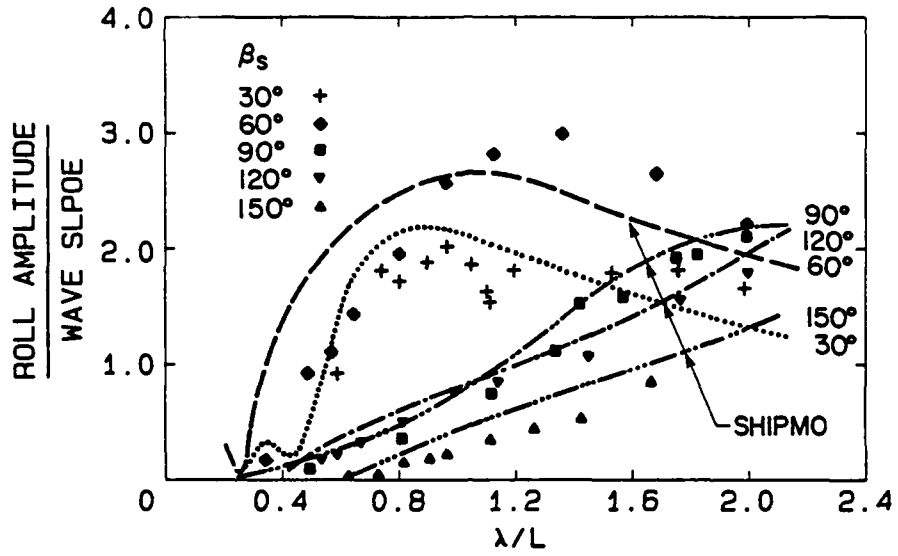

(c) Roll

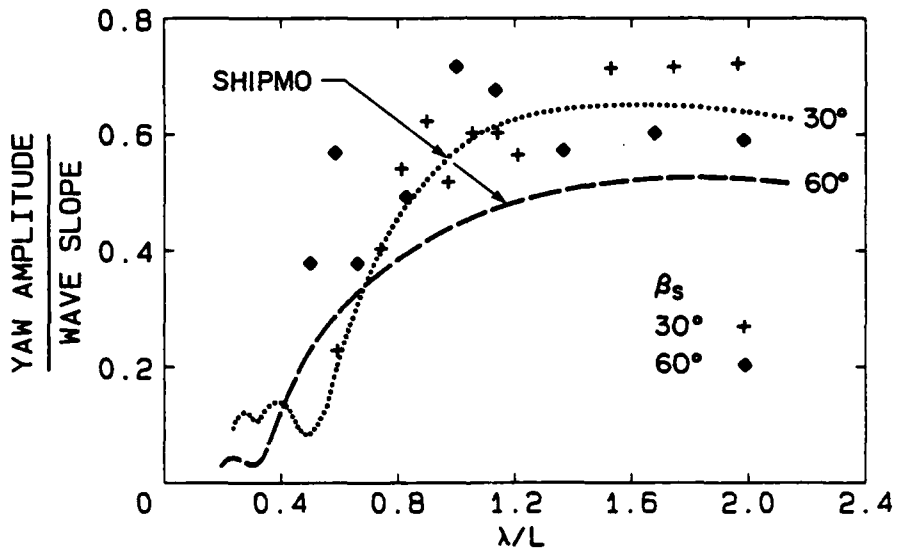

(d) Yaw

Figure A.1 cont'd

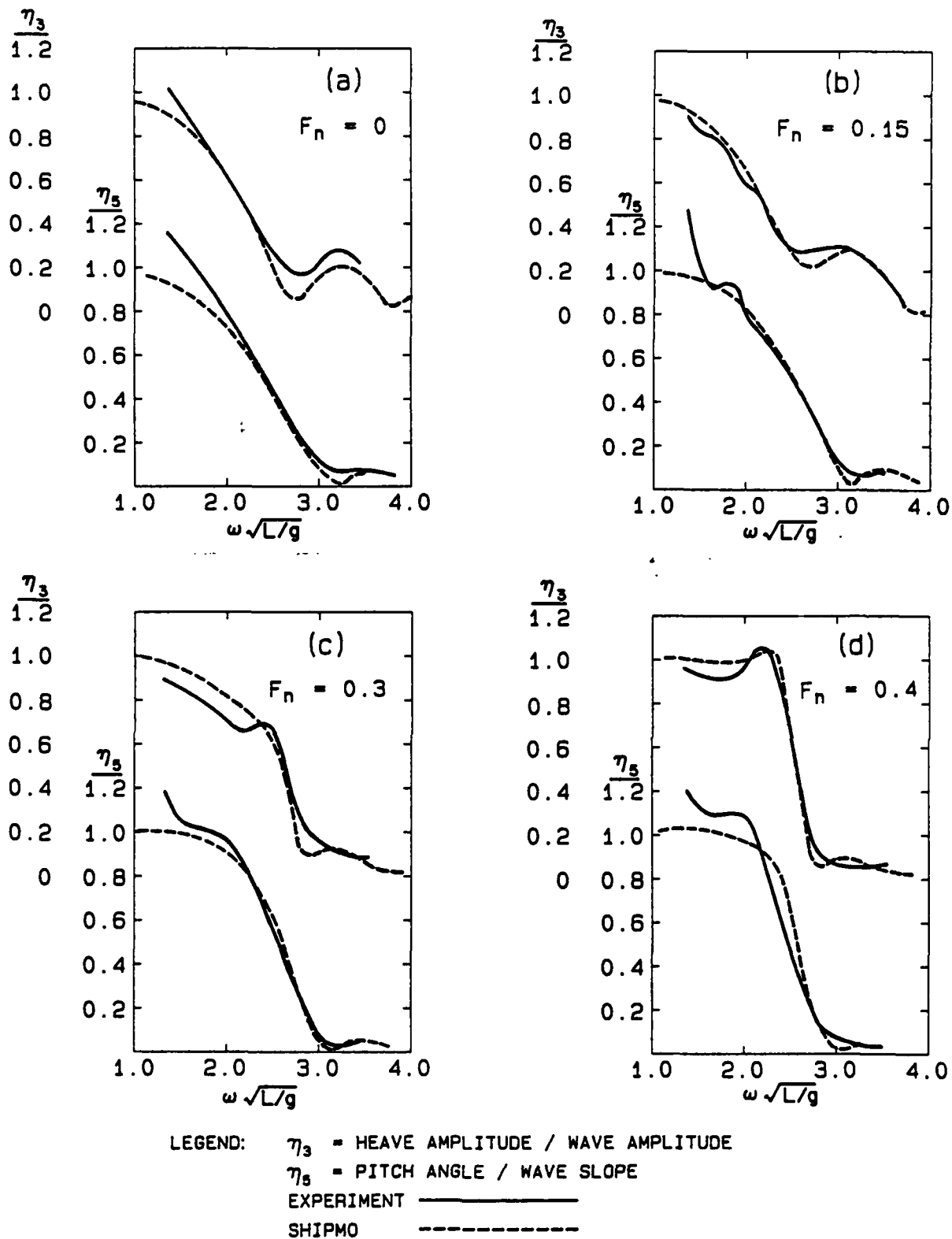

Fig. A2. Motions of Destroyer Model II in Regular Waves.

REFERENCES

1. Ando, S.: "Wave Load Prediction for the SHIPMO Computer Program", DREA Technical Memorandum 82/L, October 1982.
2. Schmitke, R.T. and Whitten, B.: "SHIPMO - A FORTRAN Program to Predict Ship Motions in Waves", DREA Technical Memorandum 81/C, September 1981.
3. Salvesen, N., Tuck, E.O., and Faltinsen, O: "Ship Motions and Sea Loads", Trans. SNAME, Vol. 78, 1978.
4. Schmitke, R.T.: "ROLLRFT, A FORTRAN Program to Predict Ship Roll, Sway and Yaw Motions in Oblique Waves, Including the Effect of Rudder, Fin and Tank Roll Stabilizers", DREA Technical Memorandum 78/G, December 1978.
5. Lloyd, A.R.J.M., Brown, J.C., and Anslow, J.F.W.: "Motions and Loads on Ship Models in Regular Oblique Waves", RINA Occasional Publication No. 3, 1980; Trans. RINA, Vol. 122; and the Naval Architect, No. 1, January 1980.
6. Nethercote, W.C.E.: "Motions and Bending Moments of a Warship Design", The Naval Architect, No. 4, July 1981.
7. Numata, E.: "Longitude Bending and Torsional Moments Acting on a Ship Model of Oblique Headings to Waves", Journal of Ship Research, Vol. 4, No. 1, p. 35, 1960.
8. Wahab, R.: "Amidships Forces and Moments on a $C_B = 0.80$ Series 60' Model in Waves from Various Directions", Netherlands Ship Research Centre TNO, Report No. 100S, November 1967.
9. Chiocco, M.J. and Numata, E.: "Midship Wave Bending Moments in a Model of the Cargo Ship 'Wolverine State' Running at Oblique Headings in Regular Waves", NAVSEA Ship Structure Committee Report SSC-201 (AD-695123), November 1969.
10. Kaplan, P.: "Evaluation and Verification of Computer Calculations of Wave-Induced Ship Structural Loads", NAVSEA Ship Structure Committee Report SSC-229 (AD-753220), July 1972.
11. Graham, R.: "Ship Motion Program SHIPMO - Model Test Correlations and Suggestion for Use", DREA Technical Memorandum in print.

UNLIMITED DISTRIBUTION

UNCLASSIFIED

Security Classification

DOCUMENT CONTROL DATA - R & D		
(Security classification of title, body of abstract and indexing annotation must be entered when the overall document is classified)		
1. ORIGINATING ACTIVITY		2a. DOCUMENT SECURITY CLASSIFICATION
		2b. GROUP
3. DOCUMENT TITLE		
Correlation of Wave Loads Predicted by the Extended SHIPMO Computer Program with Experiments		
4. DESCRIPTIVE NOTES (Type of report and inclusive dates)		
5. AUTHOR(S) (Last name, first name, middle initial)		
ANDO, S.		
6. DOCUMENT DATE	7a. TOTAL NO. OF PAGES	7b. NO. OF REFS
AUGUST 1985	38	11
8a. PROJECT OR GRANT NO.	8a. ORIGINATOR'S DOCUMENT NUMBER(S)	
	DREA TECHNICAL MEMORANDUM 85/218	
8b. CONTRACT NO.	8b. OTHER DOCUMENT NO.(S) (Any other numbers that may be assigned this document)	
10. DISTRIBUTION STATEMENT		
11. SUPPLEMENTARY NOTES	12. SPONSORING ACTIVITY	
13. ABSTRACT		
<p>Wave loads predicted by the extended SHIPMO computer program were compared with experimental data in an attempt to assess the range of validity and to estimate the uncertainty of the predictions. In general, the agreement between theory and experiment was good for the vertical bending moment, but fair to poor for the horizontal bending moment. The predicted torsional moment was found to be in gross disagreement with the measured values in terms of both magnitude and trend. It was not possible to find any correlation of the pattern of the discrepancy between theory and experiment with the principal design characteristics, such as hull form or weight distribution. The present comparison shows that the prediction of ship motions in oblique seas needs to be further improved. Also, systematic model tests covering a wide range of the variables are required to assess the uncertainty of the measurement, and hence, to determine the range of confidence of the predicted loads more clearly.</p>		

D513
74-478

KEY WORDS

correlation study
 wave loads
 bending moments
 ship motions
 regular wave responses
 ship hulls

INSTRUCTIONS

1. **ORIGINATING ACTIVITY:** Enter the name and address of the organization issuing the document.
- 2a. **DOCUMENT SECURITY CLASSIFICATION:** Enter the overall security classification of the document including special warning terms whenever applicable.
- 2b. **GROUP:** Enter security reclassification group number. The three groups are defined in Appendix 'M' of the DRB Security Regulations.
3. **DOCUMENT TITLE:** Enter the complete document title in all capital letters. Titles in all cases should be unclassified. If a sufficiently descriptive title cannot be selected without classification, show title classification with the usual one-capital-letter abbreviation in parentheses immediately following the title.
4. **DESCRIPTIVE NOTES:** Enter the category of document, e.g. technical report, technical note or technical letter. If appropriate, enter the type of document, e.g. interim, progress, summary, annual or final. Give the inclusive dates when a specific reporting period is covered.
5. **AUTHOR(S):** Enter the name(s) of author(s) as shown on or in the document. Enter last name, first name, middle initial. If military, show rank. The name of the principal author is an absolute minimum requirement.
6. **DOCUMENT DATE:** Enter the date (month, year) of Establishment approval for publication of the document.
- 7a. **TOTAL NUMBER OF PAGES:** The total page count should follow normal pagination procedures, i.e., enter the number of pages containing information.
- 7b. **NUMBER OF REFERENCES:** Enter the total number of references cited in the document.
- 8a. **PROJECT OR GRANT NUMBER:** If appropriate, enter the applicable research and development project or grant number under which the document was written.
- 8b. **CONTRACT NUMBER:** If appropriate, enter the applicable number under which the document was written.
- 9a. **ORIGINATOR'S DOCUMENT NUMBER(S):** Enter the official document number by which the document will be identified and controlled by the originating activity. This number must be unique to this document.
- 9b. **OTHER DOCUMENT NUMBER(S):** If the document has been assigned any other document numbers (either by the originator or by the sponsor), also enter this number(s).
10. **DISTRIBUTION STATEMENT:** Enter any limitations on further dissemination of the document, other than those imposed by security classification, using standard statements such as:
 - (1) "Qualified requesters may obtain copies of this document from their defence documentation center."
 - (2) "Announcement and dissemination of this document is not authorized without prior approval from originating activity."
11. **SUPPLEMENTARY NOTES:** Use for additional explanatory notes.
12. **SPONSORING ACTIVITY:** Enter the name of the departmental project office or laboratory sponsoring the research and development. Include address.
13. **ABSTRACT:** Enter an abstract giving a brief and factual summary of the document, even though it may also appear elsewhere in the body of the document itself. It is highly desirable that the abstract of classified documents be unclassified. Each paragraph of the abstract shall end with an indication of the security classification of the information in the paragraph (unless the document itself is unclassified) represented as (TS), (S), (C), (R), or (U).

The length of the abstract should be limited to 20 single-spaced standard typewritten lines; 7/8 inches long.
14. **KEY WORDS:** Key words are technically meaningful terms or short phrases that characterize a document and could be helpful in cataloging the document. Key words should be selected so that no security classification is required. Identifiers, such as equipment model designation, trade name, military project code name, geographic location, may be used as key words but will be followed by an indication of technical context.

END

FILMED

1-86

DTIC