

AD-A162 633

ANALYSIS AND COMPARISON OF TWO HF (HIGH-FREQUENCY)  
TRAIN ANTENNAS. (U) HOCHSCHULE DER BUNDESMEHR MUNICH  
(GERMANY F R) INST FOR HIGH-... G FLACHENECKER ET AL.  
JUL 84 R/D-4428/EE-09 DAJA45-83-M-0271 F/G 9/5

1/1

UNCLASSIFIED

NL

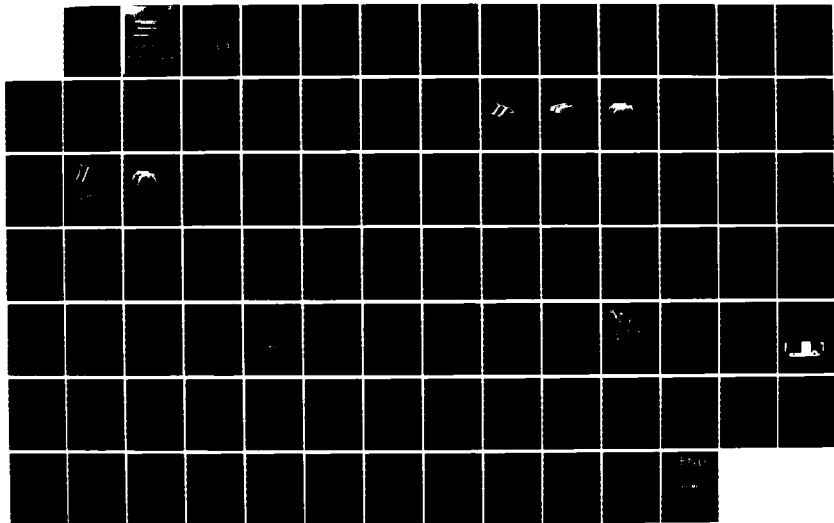

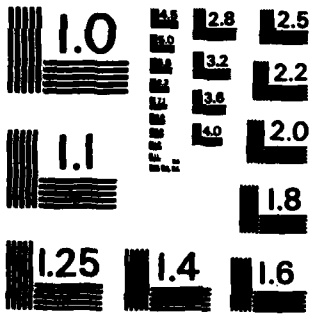

MICROCOPY RESOLUTION TEST CHART  
NATIONAL BUREAU OF STANDARDS-1963-A



UNCLASSIFIED

SECURITY CLASSIFICATION OF THIS PAGE (When Data Entered)

RD 4420-EE-09

REPORT DOCUMENTATION PAGE		READ INSTRUCTIONS BEFORE COMPLETING FORM
1. REPORT NUMBER	2. GOVT ACCESSION NO. ADA 162633	3. RECIPIENT'S CATALOG NUMBER
4. TITLE (and Subtitle) ANALYSIS AND COMPARISON OF TWO HF-TRAIN ANTENNAS		5. TYPE OF REPORT & PERIOD COVERED Technical Report Aug 83 - Feb 84
7. AUTHOR(s) G. Flachenecker and J. Brose		6. PERFORMING ORG. REPORT NUMBER
9. PERFORMING ORGANIZATION NAME AND ADDRESS Hochschule der Bundeswehr München Werner-Heisenberg-Weg 39 8014 Neubiberg, Germany		8. CONTRACT OR GRANT NUMBER(s) DAJA45-83-M-0271
11. CONTROLLING OFFICE NAME AND ADDRESS USARDCG-UK Box 65, FPO NY 09510		10. PROGRAM ELEMENT, PROJECT, TASK AREA & WORK UNIT NUMBERS 6.11.02A IT161102B457-03
14. MONITORING AGENCY NAME & ADDRESS (if different from Controlling Office)		12. REPORT DATE July 1984
		13. NUMBER OF PAGES 90
		15. SECURITY CLASS. (of this report) Unclassified
16. DISTRIBUTION STATEMENT (of this Report)  Approved for Public Release; distribution unlimited		15a. DECLASSIFICATION/DOWNGRADING SCHEDULE
17. DISTRIBUTION STATEMENT (of the abstract entered in Block 20, if different from Report)		
18. SUPPLEMENTARY NOTES		
19. KEY WORDS (Continue on reverse side if necessary and identify by block number) HF range, HF antenna, train antenna, low profile antenna, antenna pattern, antenna losses, antenna efficiency, antenna coupler, coupler losses, antenna bandwidth, antenna tuning.		
20. ABSTRACT (Continue on reverse side if necessary and identify by block number) Analysis of a currently used low profile train antenna. Calculation of the antenna losses, coupler losses, overall efficiency and radiation patterns. Development of an improved antenna structure and calculation of the corresponding parameters. Experimental verification of the theoretical results.		

**SD**  
**DTIC**  
**ELECTE**  
**DEC 26 1985**  
**ED**

## Table of Contents

1.	Introduction .....	1
2.	Antenna calculation .....	3
2.1.	Radiation pattern .....	3
2.2.	Radiation resistance .....	21
2.3.	Imaginary part of the antenna impedance .....	34
2.4.	Losses .....	36
2.5.	Problems .....	40
3.	Transmission line .....	40
3.1.	Losses of the coaxial feeder line .....	40
3.2.	Transformation of the coaxial line .....	41
4.	Antenna coupler (HARRIS RF615B) .....	42
4.1.	Circuit diagram and functions .....	42
4.2.	Losses of the coupler elements .....	42
4.3.	Calculation of the coupler transformation .....	44
5.	Calculation of powers, voltages, and currents .....	46
6.	Optimization of the antenna .....	47
7.	Bandwidth of the tuned antenna .....	55
8.	Measurement results .....	55
Appendix A: Bibliography .....		69
Appendix B: Computer programs .....		70

<b>Accession For</b>	
NTIS GRA&I	<input checked="" type="checkbox"/>
DTIC TAB	<input type="checkbox"/>
Unannounced	<input type="checkbox"/>
Justification	
By _____	
Distribution/ _____	
<b>Availability Codes</b>	
Avail and/or	
Dist	Special
<b>A-1</b>	

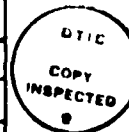

## 1. Introduction

For telecommunication links in the HF range an antenna installed on top of a railroad train had to be optimized. The specifications are:

- total maximum height of antenna:  $h_{\max} = 0.23\text{m}$
- total maximum length of antenna:  $a_{\max} = 25\text{m}$
- tunable to a source impedance of 50 Ohm by help of a standard type antenna coupler in the frequency range from 3 to 5MHz and a maximum standing wave ratio of  $\text{SWR}_{\max} = 2$ .

Because of the height limitations only a loop antenna is usable. One train, equipped with a loop antenna of 7.5m length, 0.23m height and 0.075m diameter (Fig.1) has been investigated. This antenna will be referred to as "type 1".

Another antenna construction is proposed in /1/. It consists of two symmetrical antenna parts fed by a coaxial line, the outer conductor of which is one antenna element (Fig.2). This shielded-loop antenna will be referred to as "type 2".

The two antenna types differ in

- impedance (real- and imaginary part)
- radiation pattern.

The radiation resistance of both antenna types is very low, but the resistance of type 1 is significantly lower than type 2. The imaginary part of the antenna impedance is inductive for type 1 and capacitive for type 2, if the length is optimized. Therefore type 2 can be matched easier to the source impedance with a coupler that has been constructed for a capacitive whip antenna (Harris antenna-coupler RF-615B).

The radiation pattern in the horizontal plane is a figure-eight pattern for both antennas. For ground-wave links, type 2 will only work sufficiently in the direction the train goes to or comes from. Type 1 radiates omnidirectional since the opposite fields of the two vertical antenna elements (i.e. feeder and short circuit) have different magnitudes.

The main problem of the total antenna system is the coupler. Several Milliohms of radiation resistance has to be transformed to 50 Ohms, while some hundred Ohms of the imaginary part of the antenna impedance has to be compensated for. Typically about 90 percent of the transmitter's available power is converted to heat inside the coupler.

According to the strong influence of the coupler on the whole

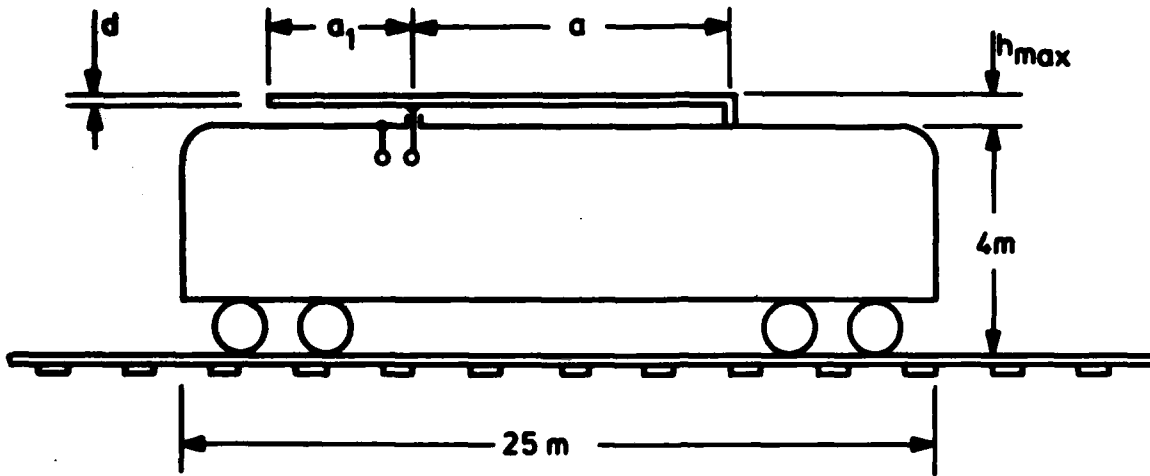

**Fig. 1:** Outline dimensions of antenna type 1:  
 $a = 7.5\text{m}$ ,  $a_1 = 1.5\text{m}$ ,  $d = 0.075\text{m}$ ,  $h_{max} = 0.23\text{m}$

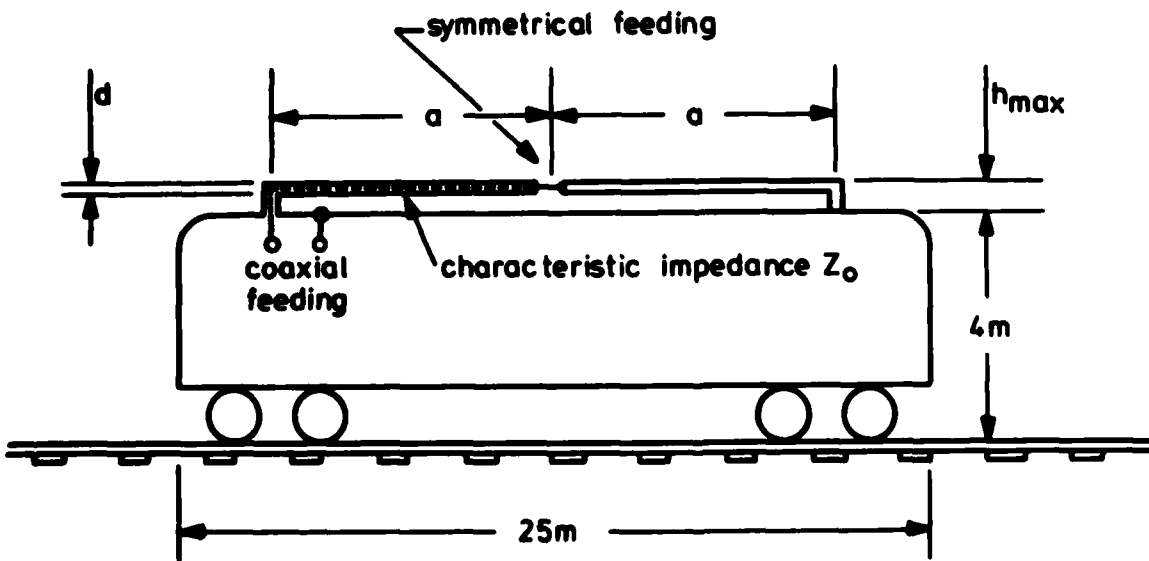

**Fig. 2:** Construction of antenna type 2

antenna system it is obviously necessary to know precise data of all coupler elements. This data was taken from a slightly smaller, but comparable coupler.

With this data the total antenna efficiency ((radiated power)/(power, available from the generator)) for type 1 has been calculated utilizing the length, the diameter and the number of antenna elements and for type 2, the influence of the characteristic impedance of the coaxial feeder-line.

It can be shown that at the most critical frequency - 3MHz - a total efficiency of up to 12% is possible if the optimum value of each parameter is chosen. On the other hand the antenna optimized for 3MHz cannot be matched to the transmitter at 4MHz or 5MHz with the available HARRIS-coupler. Because of this, a compromise between maximum efficiency and necessary tuning bandwidth must be made.

## 2. Antenna calculation

The dimensions of antenna type 1 and 2 are shown in Fig.1 and Fig.2, respectively.

To simplify the numerical calculations, the conductivity of the antenna elements is initially assumed to be infinite. Therefore, the cylindrical surface of every antenna element can be substituted by a line current at a height of

$$h = \sqrt{h_{\max} \cdot (h_{\max} - d)} \quad (1)$$

above ground. The real antenna surface coincides with one equipotential surface of this current filament (see Fig.3).

The roof of the train can be substituted by using the image of the real antenna.

The distance between roof and ground can be neglected, as the current density at the vertical walls of the train is definitely much smaller than the current density at the antenna elements and their images (as in reality, the antenna is close to the roof).

Because of these simplifications the final configurations of the antennas are as shown in Fig.4.

### 2.1 Radiation pattern

The radiation pattern can be calculated by summing-up the retarded potentials of the antenna currents far away from the antenna (far-field pattern) for each direction. In // this has

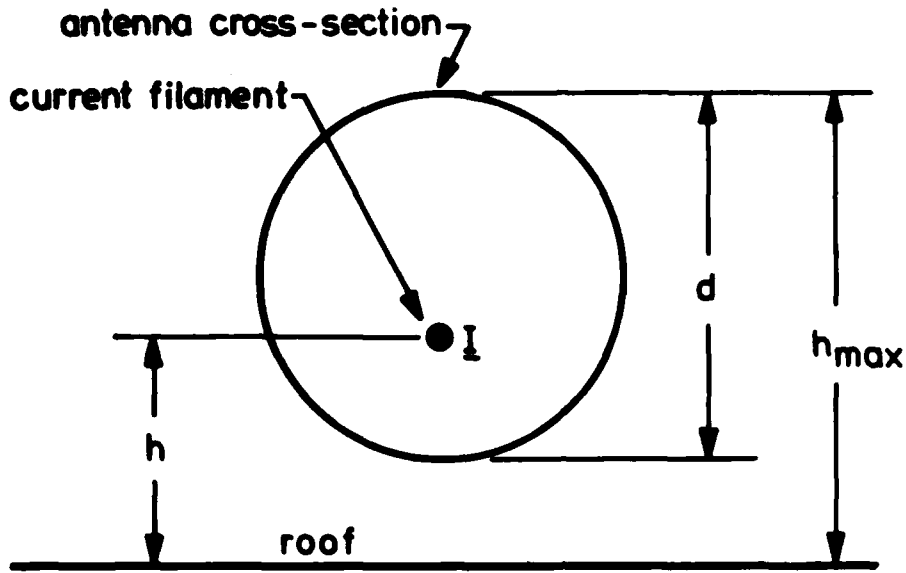

Fig. 3a: Substitution of the conducting antenna surface by a current filament  $I$  of the height  $h$  above ground (roof)

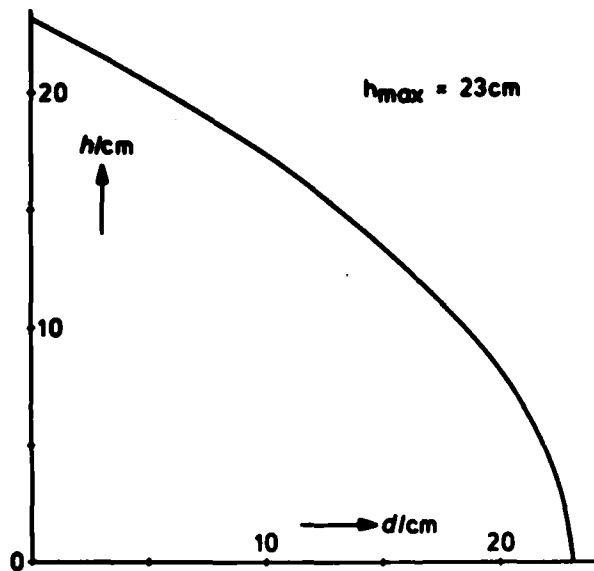

Fig. 3b: Hight  $h$  of the current filament versus the antenna diameter  $d$

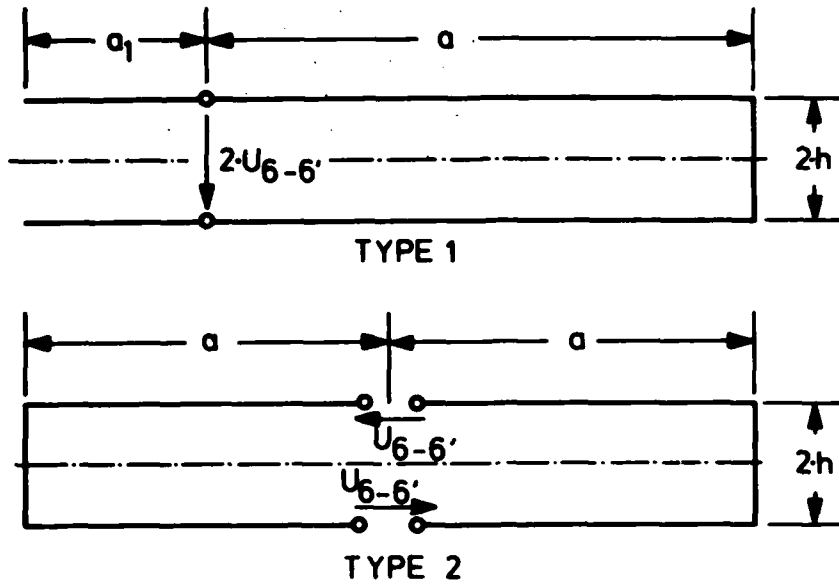

Fig. 4: Simplified configuration of antenna type 1 and type 2

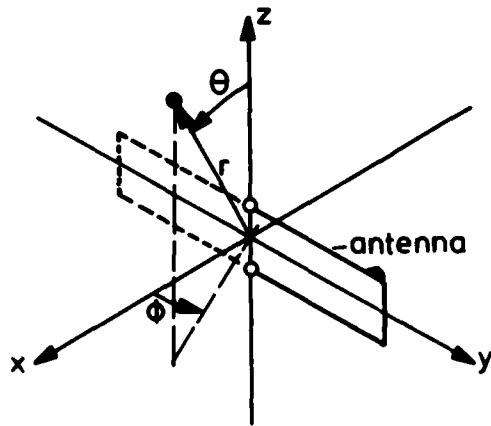

Fig. 5: Position of the antenna in the centre of the used coordinates

been done in a closed analytic form.

To enable a more simplified explanation a numerical method has also been used:

As shown in Fig.6 the simplified antenna is positioned to the centre of a spherical  $(\phi, \theta, r)$  coordinate system. In a corresponding x-y-z-system the railroad would coincide with the y-axis. The antenna current in a good approach is sinusoidal, with a maximum current through the shortcircuit termination, represented by the vertical rods ( $y = \pm a$ ):

$$\underline{I}(y) = \underline{I}(0) \cdot \frac{\cos[\beta_0(a-|y|)]}{\cos(\beta_0 \cdot a)} \quad (2)$$

where  $\beta_0 = \frac{2\pi}{\lambda_0}$

and  $I(0)$  = current at the feeding point.

The antenna and its image are then subdivided into  $k$  parts, each with approximately constant current distribution.

Each part acts as a Hertzian electric dipole of the length  $l$ :

$$l = \frac{a}{k+1} \quad (3)$$

The magnetic far-field at the distance  $R_0$  in the directions  $\phi$  and  $\theta$  (vector  $\vec{r}_0$ ), caused by the  $i$ -th horizontal electric current element  $\underline{I}_i = \underline{I}(y = y_i)$  is:

$$\underline{H}_\theta = j \cdot \frac{\underline{I}_i}{2 \cdot R_0} \cdot \frac{1}{\lambda_0} \cdot \cos\phi \quad (4)$$

$$\underline{H}_\phi = -j \cdot \frac{\underline{I}_i}{2 \cdot R_0} \cdot \frac{1}{\lambda_0} \cdot \cos\theta \cdot \sin\phi \quad (5)$$

The locus vector  $\vec{r}_i$  of the centre of each horizontal Hertzian electric dipole is in Cartesian coordinates:

$$\vec{r}_i = \begin{pmatrix} 0 \\ \frac{1}{2} + i \cdot l \\ \pm h \end{pmatrix} \quad (6)$$

where  $i = 0 \dots k$  for type 1 and  $i = -k \dots k$  for type 2

The path difference of a wave caused by the  $i$ -th electric current element with respect to the antenna centre is:

$$\Delta_i = \vec{r}_i \cdot \frac{\vec{r}_0}{r_0} \quad (7)$$

For any current element with the coordinates  $x_i$ ,  $y_i$ , and  $z_i$  this leads to:

$$\Delta_i = x_i \cdot \sin\theta \cdot \cos\phi + y_i \cdot \sin\theta \cdot \sin\phi + z_i \cdot \cos\theta \quad (7a)$$

The locus vector of the centers of either the type 1 or the type 2 vertical current elements is:

$$\vec{r}_i = \begin{pmatrix} 0 \\ \pm a \\ 0 \end{pmatrix} \quad (8)$$

The current in this element is the maximum current of the antenna

$$\underline{I}_m = \frac{\underline{I}(0)}{\cos(\beta_0 \cdot a)} \quad (9)$$

The element's length is:

$$l_m = 2 \cdot h \quad (10)$$

and its magnetic far-field is:

$$\underline{H}_\phi = -j \cdot \frac{\underline{I}_m}{2 \cdot R_0} \cdot \frac{l_m}{\lambda_0} \cdot \sin\theta \quad (11)$$

Antenna type 1 is usually fed through the train's roof. The feeder line with the length  $l_m = 2h$  causes the magnetic far-field:

$$\underline{H}_\phi = j \cdot \frac{\underline{I}(0)}{2 \cdot R_0} \cdot \frac{l_m}{\lambda_0} \cdot \sin\theta \quad (11a)$$

if the length of the open-ended parallel line is  $a_1 = 0$ . Otherwise the feeder current is smaller than the horizontal current  $I(0)$ .

For any point P with the locus vector  $\vec{r}_0$  the field strengths become:

$$\underline{H}_\theta = j \cdot \frac{l \cdot \cos\phi}{2 \cdot R_0 \cdot \lambda_0} \cdot \sum_{i=s}^{i=k} \underline{I}_i \cdot [\exp(-j \cdot \beta_0 \cdot \Delta_i) - \exp(j \cdot \beta_0 \cdot \Delta_i)] \quad (12)$$

$$\underline{H}_\phi = -j \cdot \frac{1 \cdot \cos\theta \cdot \sin\phi}{2 \cdot R_o \cdot \lambda_o} \cdot \sum_{i=s}^{i=k} \underline{I}_i [\exp(-j \cdot \beta_o \cdot \Delta_i) - \exp(j \cdot \beta_o \cdot \Delta_i)] -$$

$$- j \frac{\underline{I}_m \cdot 1 \cdot \sin\theta}{2 \cdot R_o \cdot \lambda_o} \cdot \sum_{i=1}^{i=m} \exp(-j \cdot \beta_o \cdot \Delta_i) + j(2-m) \cdot \underline{I}(o) \cdot \frac{1 \cdot \sin\theta}{2 \cdot R_o \cdot \lambda_o}$$

(13)

where  $s = 0$  and  $m = 1$  for type 1 and  $s = -k$  and  $m = 2$  for type 2.

The total magnetic field strength is

$$H = \sqrt{|\underline{H}_\phi|^2 + |\underline{H}_\theta|^2}$$

(14)

The total electric field strength is

$$\underline{E} = H \cdot Z_i$$

(15)

(Intrinsic impedance  $Z_i = 120\pi\Omega$ )

The average Poynting vector is

$$S = \frac{1}{2} \cdot \underline{E} \cdot \underline{H}$$

$$= \frac{1}{2} \cdot \frac{E^2}{Z_i}$$

(16)

The radiation patterns of the two antenna types for  $\phi$  and  $\theta$ -polarization and the total field strength, respectively, have been calculated and mapped.

Fig.6 to Fig.8 show the calculated field strengths for antenna type 1. For this pattern, as well as for the following, the current  $I(0)$  at the antenna's feeding point is assumed to be constant. The patterns in the ground plane ( $\theta = 90^\circ$ ) would be exactly circular, if no vertical feeder current would be necessary. Because of the feeder current, which has a  $180^\circ$ -phase shift to the current in the short circuit the radiation in the directions  $\phi = 0^\circ$  and  $\phi = 180^\circ$  is smaller than in the directions  $\phi = \pm 90^\circ$ .

The field strength increases with the frequency, as the maximum current  $I_m$  increases depending on eq.9.

The radiation patterns in the plane  $\phi = 90^\circ$  is shown in Fig.7. In this plane the radiation is nearly independent from the elevation angle.

The radiation patterns in the plane  $\phi = 0^\circ$  show that radiation

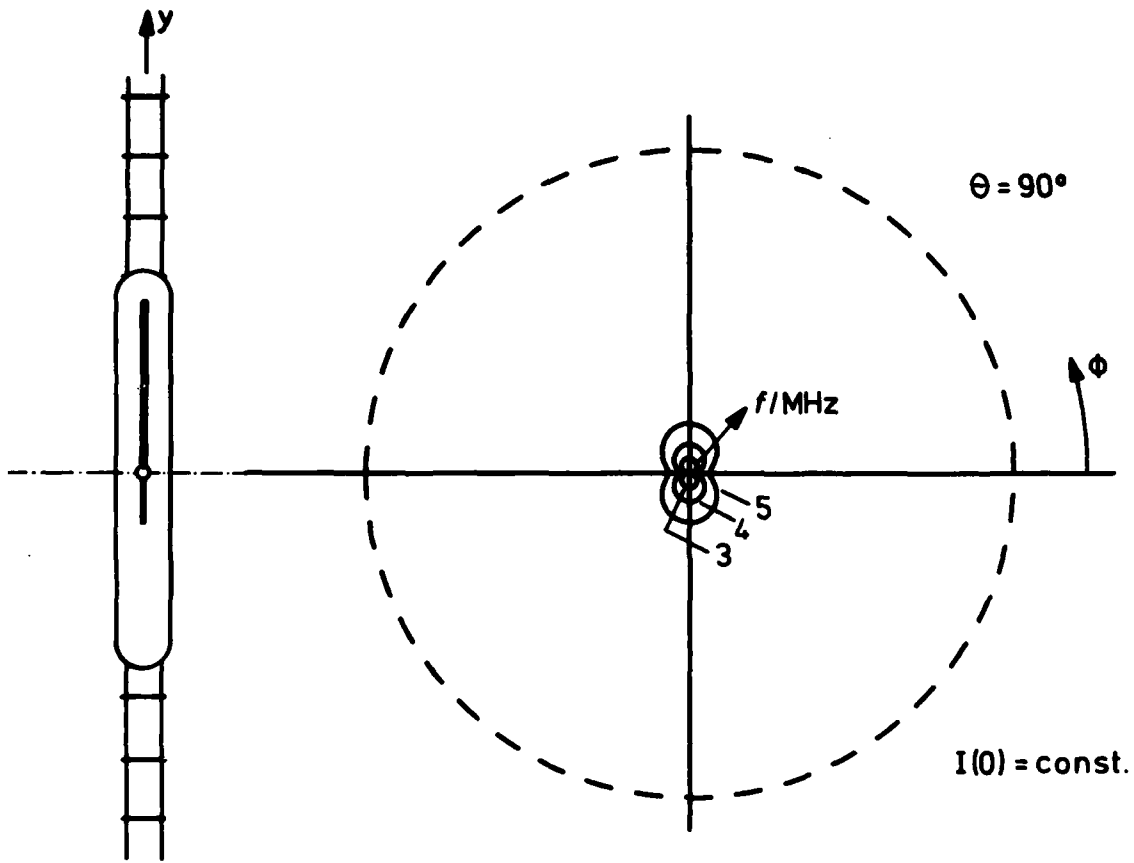

Fig. 6: Antenna type 1 - Total electrical field strength in the ground plane. Current  $I(0)$  at the feeder point is constant

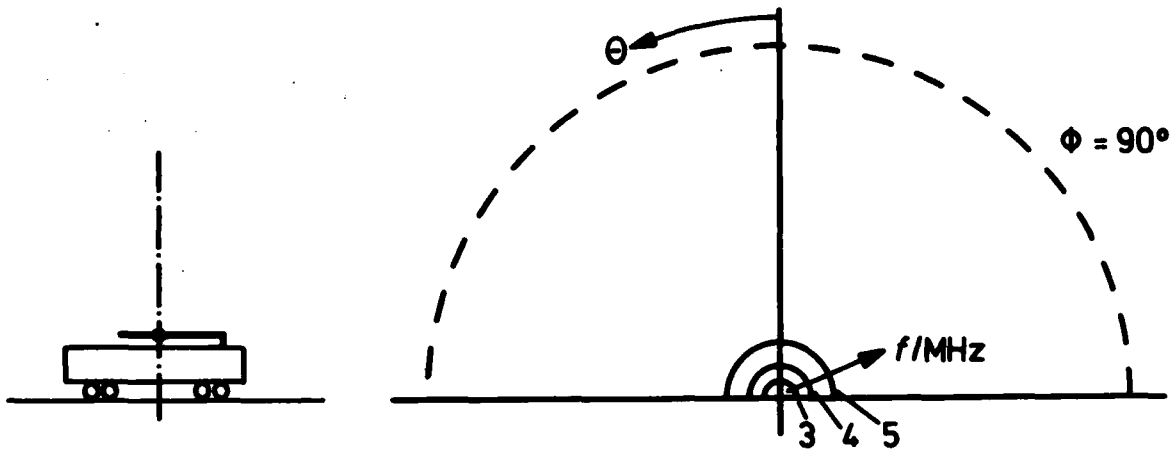

Fig. 7: Antenna type 1 - Total electrical field strength in the plane  $\phi = 90^\circ$ .  $I(o) = \text{const.}$

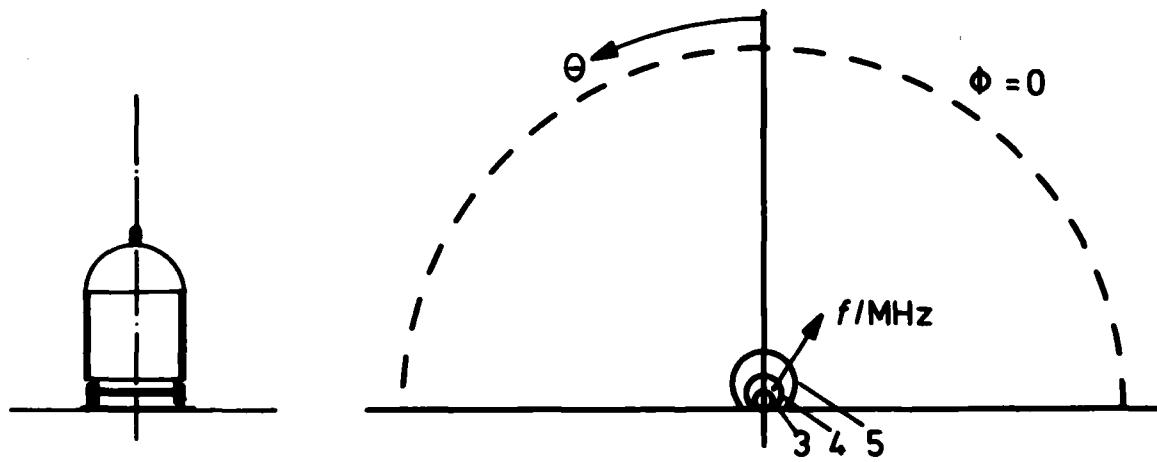

Fig. 8: Antenna type 1 - Total electrical field strength in the plane  $\phi = 0^\circ$ .  $I(o) = \text{const.}$

minima occur only at lower elevation angles (Fig.8).

Antenna type 2 has two vertical elements spaced apart the distance  $2a$  with opposite currents  $I_m$ . The fields of these two elements, therefore, are cancelled in the plane  $\phi = 0^\circ$ . As shown in Fig.9 ground-wave propagation does not occur perpendicular to the train's direction. Under most conditions this will not be disadvantageous.

Sky-wave communication links are possible in any direction, as shown in Fig.10 and Fig.11. The radiation to higher angles for type 2 is at 4MHz about 14dB higher than with antenna type 1 if the same current  $I(0)$  is flowing. It just has been pointed out that the transmitter power predominantly heats the coupler. Because of this, absolute values of the field strength can only be compared with constant available generator power. As this will be done later, and as it does not change the relative radiation pattern, the following patterns are related to the maximum field strength of each antenna at the particular frequency.

As the normalized radiation patterns obviously do not depend strongly on the frequency, only the patterns for one frequency (3MHz) are presented in the different charts.

Fig.12 shows the partial electrical field strength with  $\phi$ -polarization of antenna type 1 in the plane  $\phi = 0^\circ$ . In the planes  $\phi = 90^\circ$  and  $\theta = 90^\circ$  this partial field strength is zero. The  $\theta$ -polarized electrical field strength is represented in Fig.13 and the total field strength in Fig.14, both of them in the planes  $\phi = 90^\circ$ ,  $\phi = 0^\circ$  and  $\theta = 90^\circ$ . This shows that in the ground plane only vertical polarization occurs while at higher elevation angles  $\phi$ -polarization will be found as well as  $\theta$ -polarization.

Fig. 15 to Fig. 17 show the radiation patterns of antenna type 2, again in the planes  $\phi = 0^\circ$ ,  $\phi = 90^\circ$  and  $\theta = 90^\circ$ . The  $\phi$ -polarized E-field strength occurs, similar as with type 1, only in the plane  $\phi = 0^\circ$ . The  $\theta$ -polarized E-field strength is plotted in Fig.16. It has only slight changes in the plane  $\theta = 90^\circ$  with a maximum at  $\theta = 0^\circ$ , but has a zero at  $\phi = 0^\circ$  and  $\theta = 90^\circ$ . The polarization in the ground plane is vertical as with type 1, as the ground conductivity is assumed to be infinite. The total field strength in the upper half space is plotted for the planes  $\phi = 0^\circ$ ,  $\phi = 90^\circ$  and  $\theta = 90^\circ$  in Fig.17. This illustrates that the radiation pattern of this antenna is half a toroid with its axis in the ground plane.

Fig.18 to Fig.20 show for antenna type 1 the dependence of the  $\phi$ - and  $\theta$ -polarized electric field strength as a three-dimensional plot over the rectangular  $\phi$ - $\theta$ -plane. Using this chart, the relative field strength for every  $\phi$ - $\theta$ -direction of the upper half

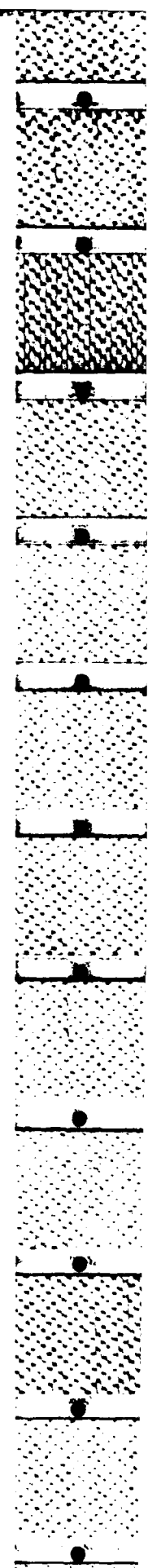

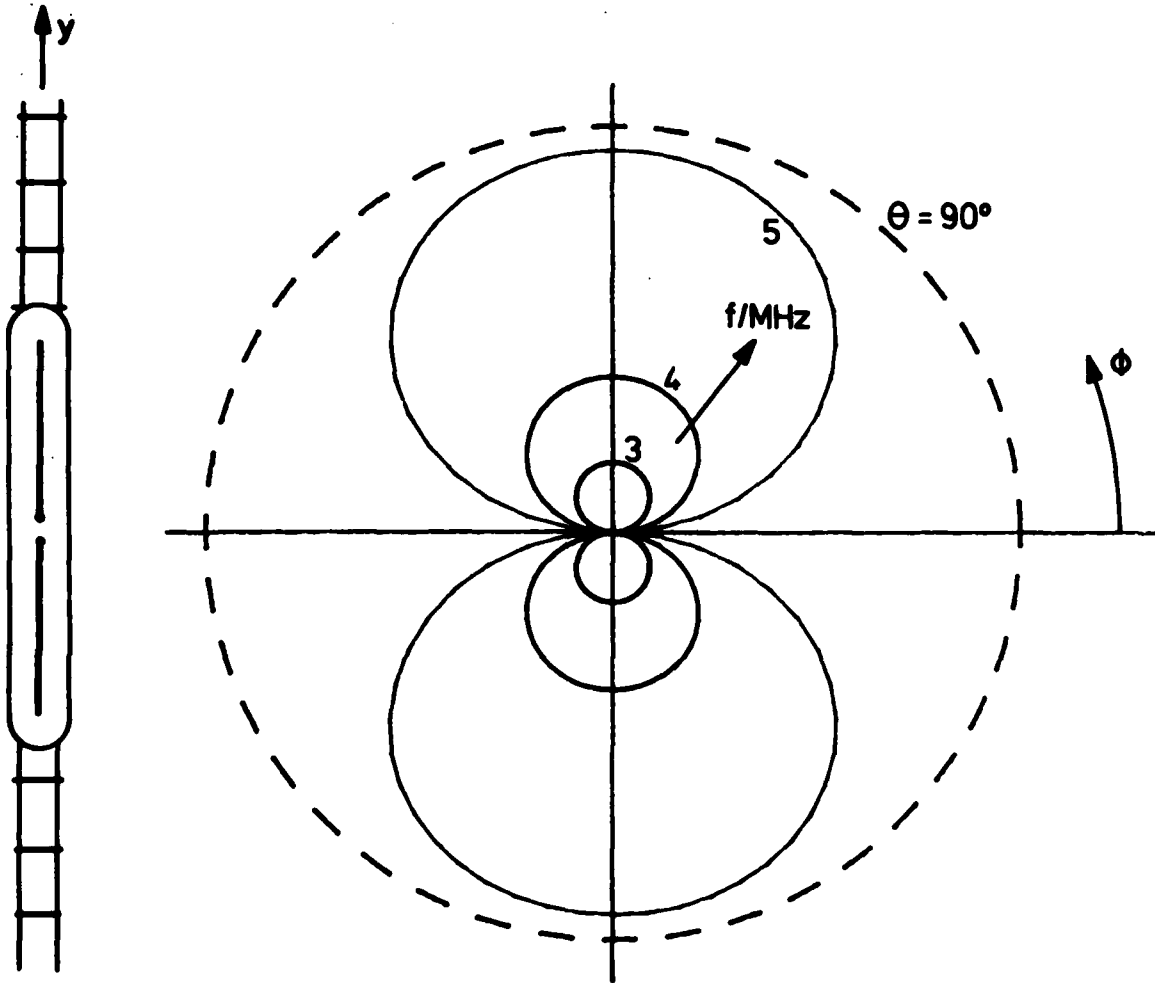

Fig. 9: Antenna type 2 - Total electrical field strength in the ground plane. Current  $I(o)$  at the feeding point is constant.

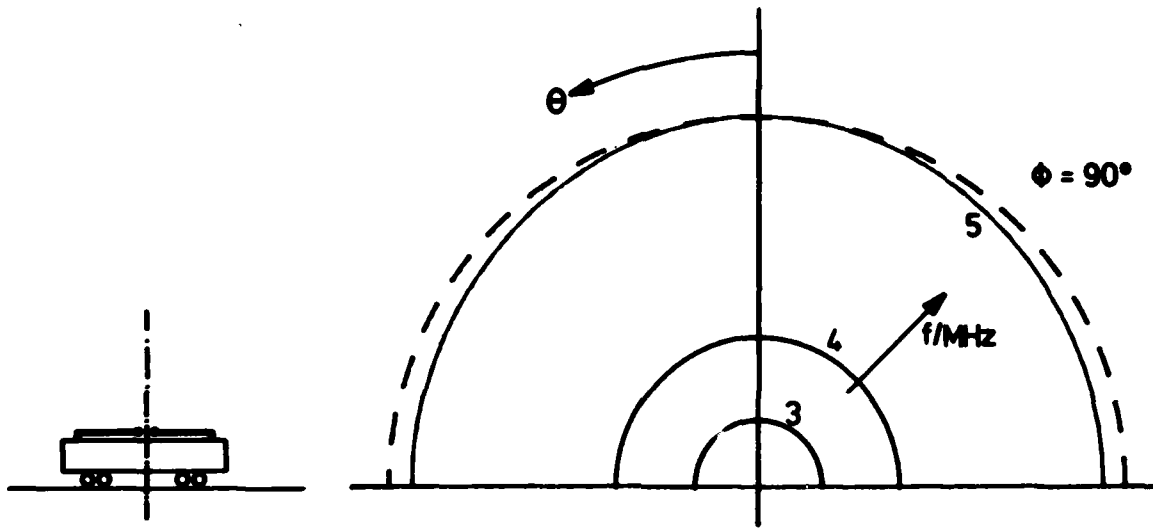

Fig. 10: Antenna type 2 - Total electrical field strength in the plane  $\phi = 90^\circ$ .  $I(o) = \text{const}$ .

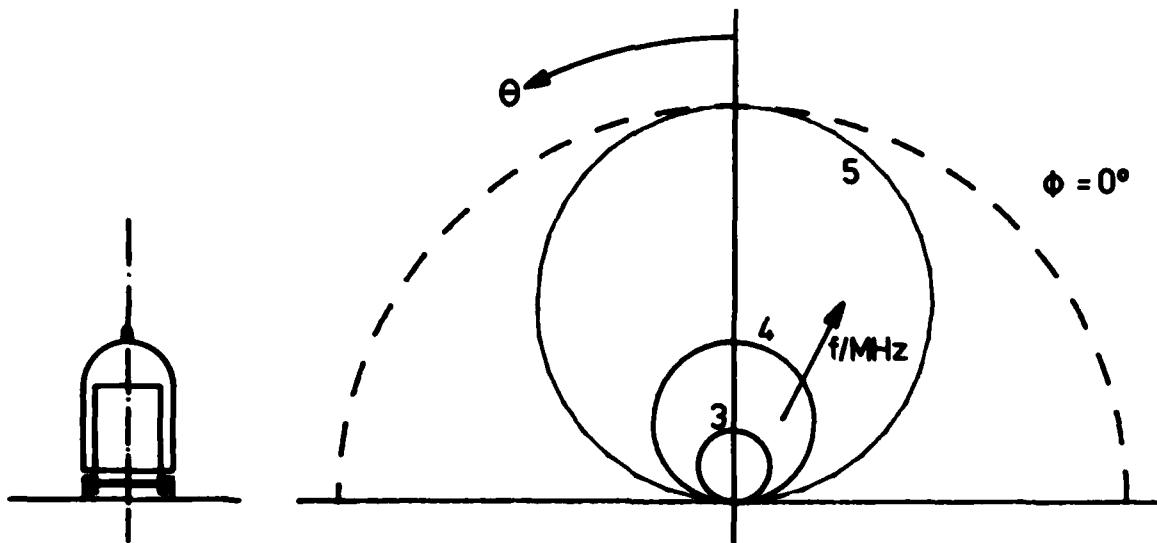
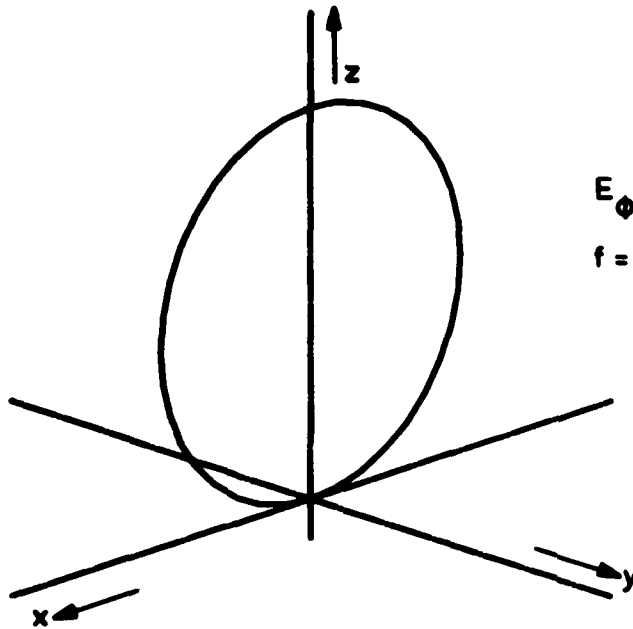

Fig. 11: Antenna type 2 - Total electrical field strength in the plane  $\phi = 0^\circ$ .  $I(o) = \text{const}$ .

TYPE 1



$E_\phi$   
 $f = 3 \text{ MHz}$

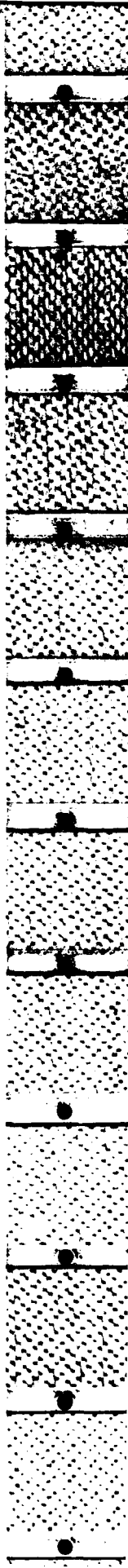
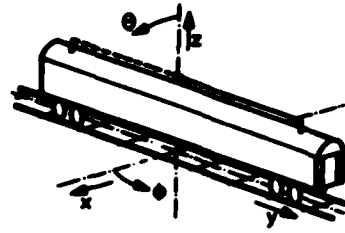
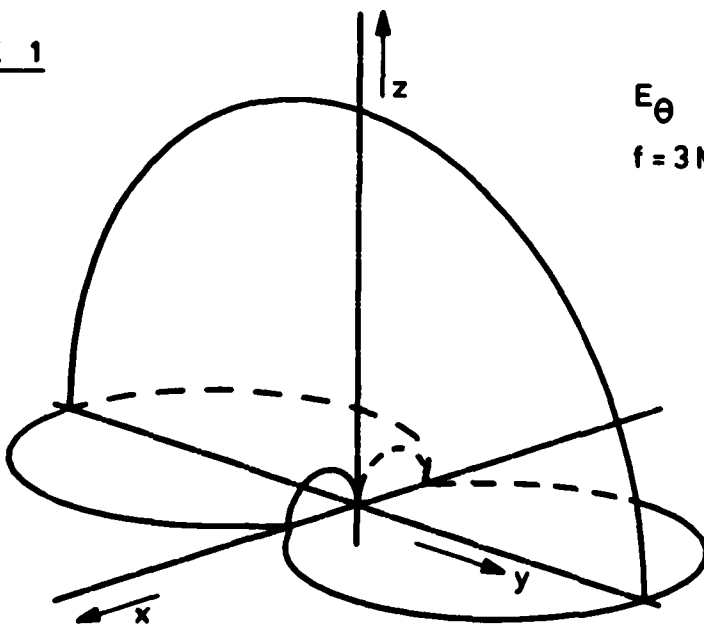

Fig. 12: Partial  $\phi$ -polarized electrical field strength

TYPE 1



$E_\theta$   
 $f = 3 \text{ MHz}$

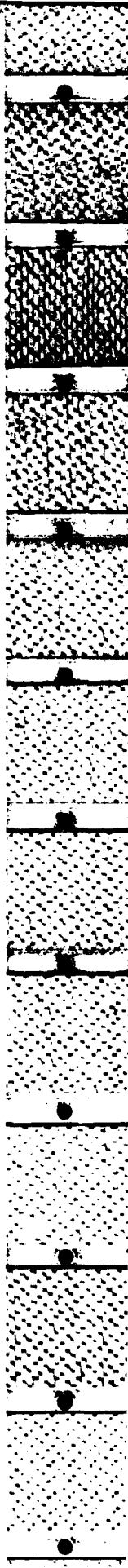
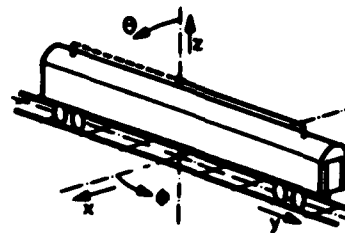
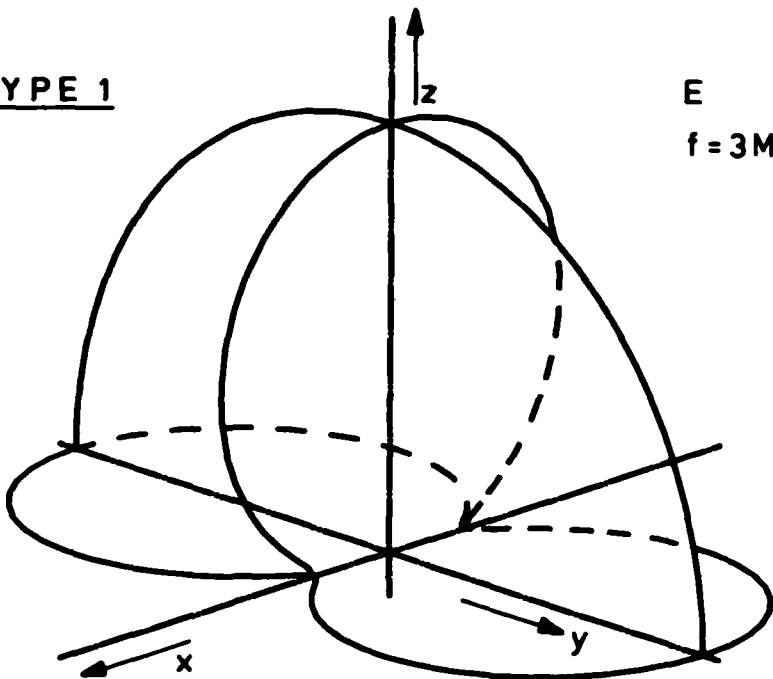

Fig. 13: Partial  $\theta$ -polarized electrical field strength

TYPE 1



E  
f = 3 MHz

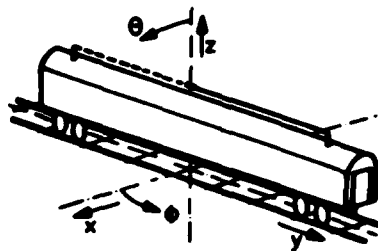
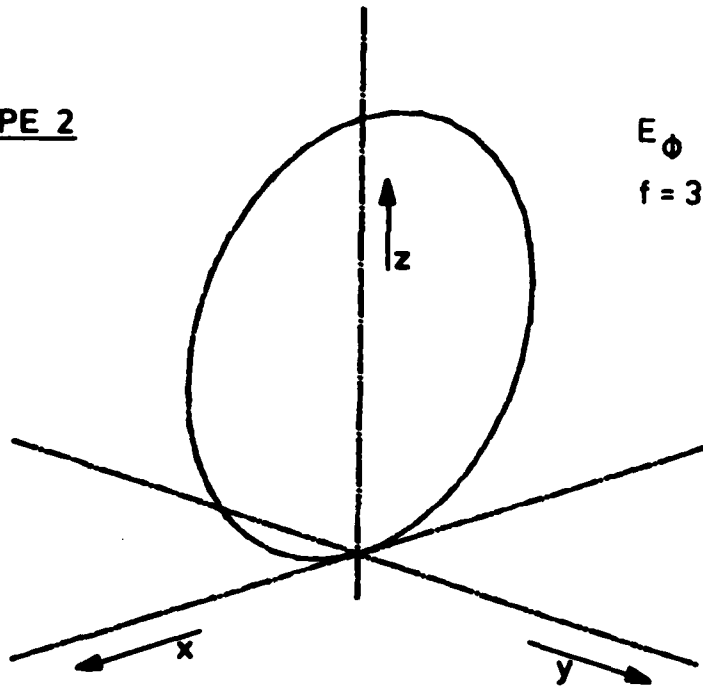

Fig. 14: Total electrical field strength

TYPE 2



$E_{\phi}$   
 $f = 3 \text{ MHz}$

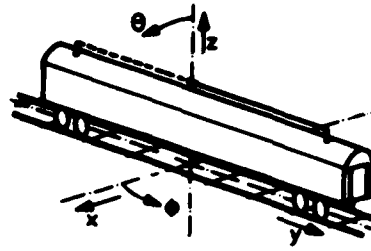
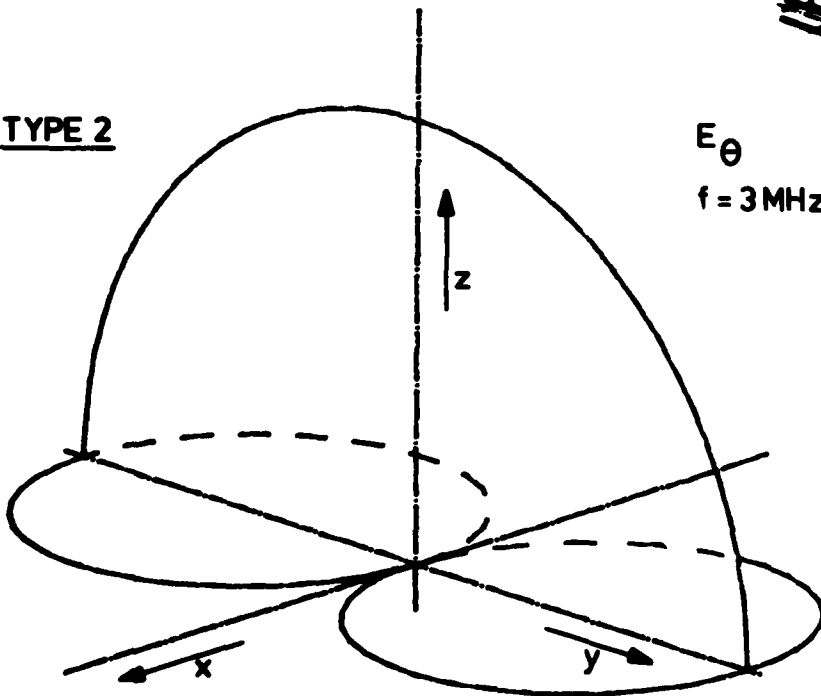

Fig. 15: Partial  $\phi$ -polarized electrical field strength

TYPE 2



$E_{\theta}$   
 $f = 3 \text{ MHz}$

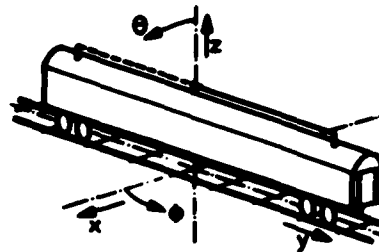

Fig. 16: Partial  $\theta$ -polarized electrical field strength

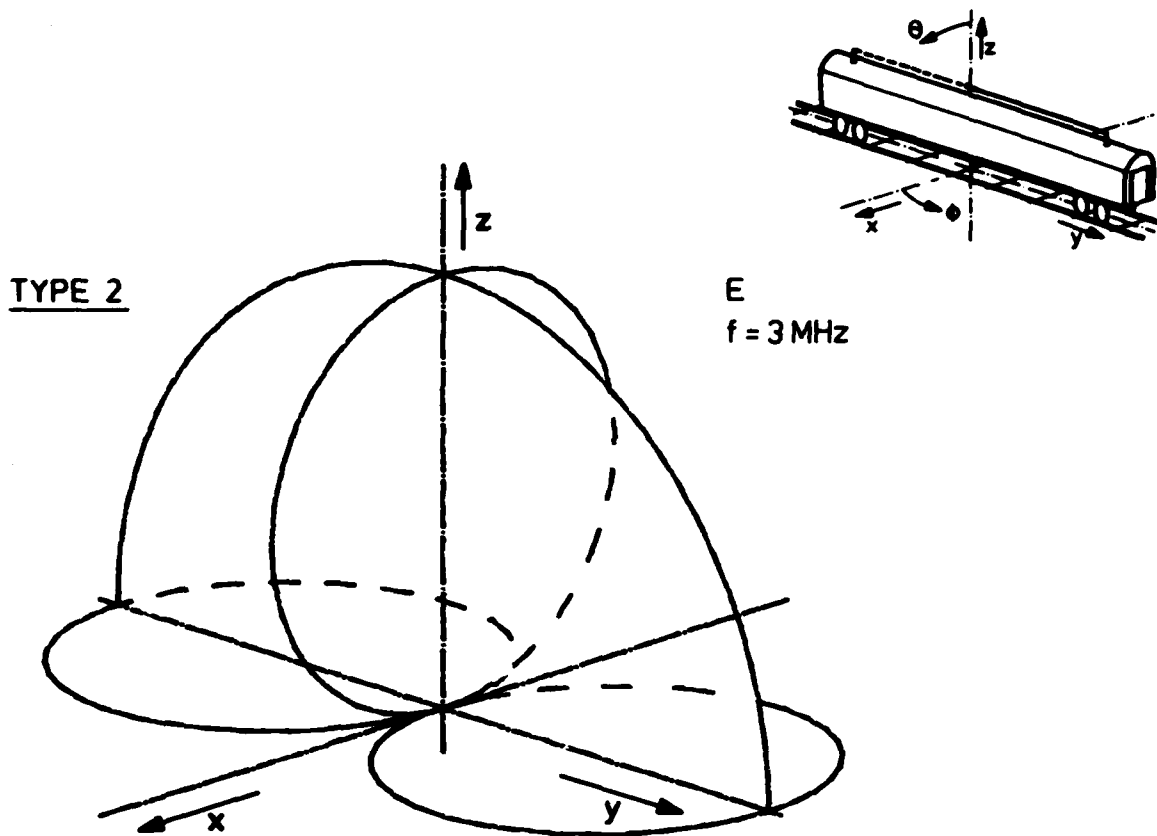

Fig. 17: Antenna type 2 - Total electrical field strength

TYPE 1

$f = 3\text{MHz}$

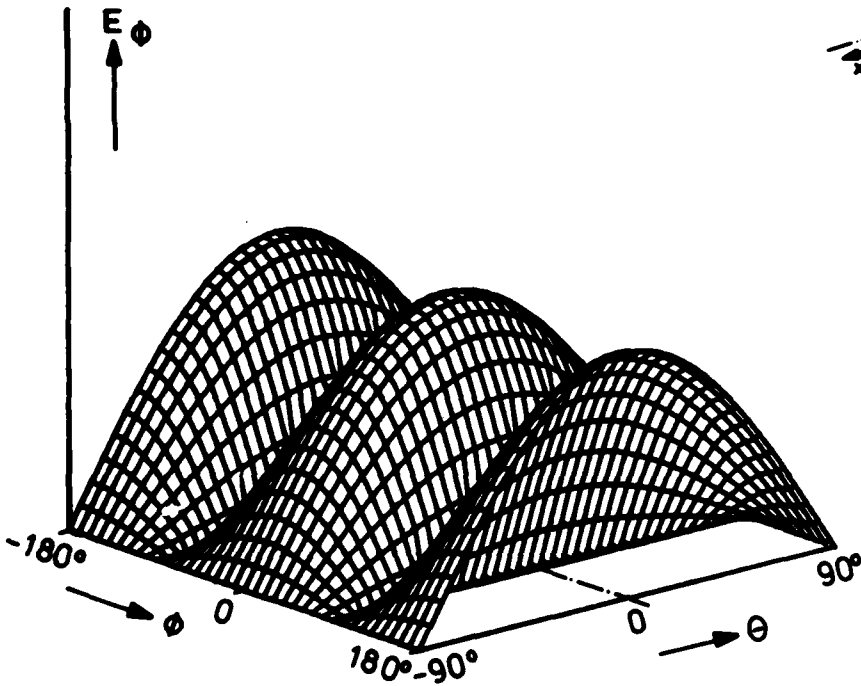
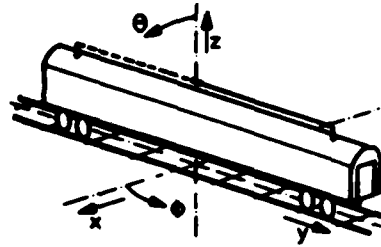

Fig. 18: Antenna type 1 - partial  $\phi$ -polarized electrical field strength over the rectangular  $\phi$ - $\theta$ -plane

TYPE 1     $f = 3\text{MHz}$

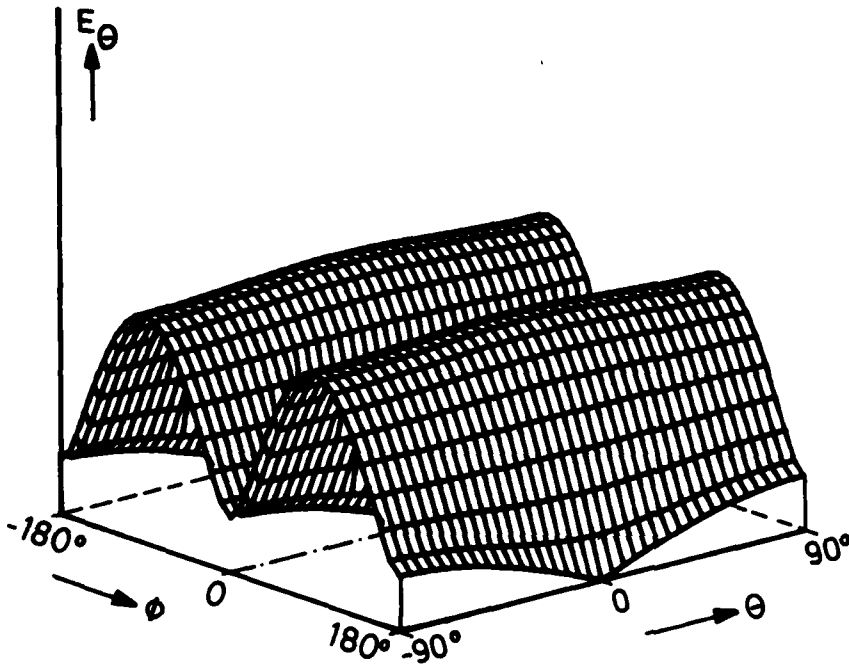
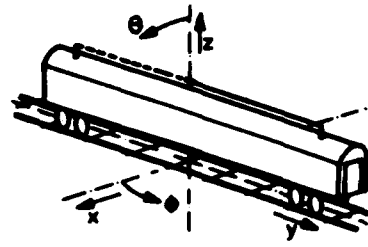

Fig. 19: Antenna type 1 - partial  $\theta$ -polarized electrical field strength over the rectangular  $\phi$ - $\theta$ -plane

TYPE 1

$f = 3\text{MHz}$

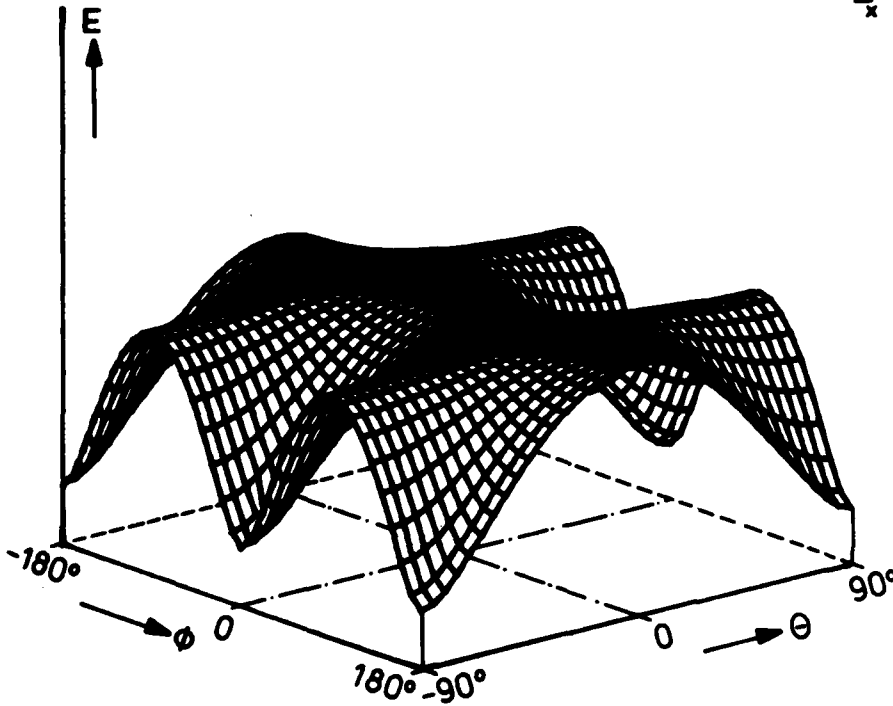
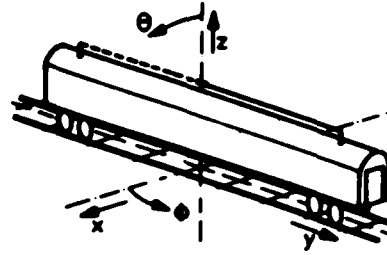

Fig. 20: Antenna type 1 - Total electrical field strength over the rectangular  $\phi$ - $\theta$ -plane

space can be obtained. Therefore, the maximum and minimum values can be found easily. Maximum radiation of antenna type 1 with  $\phi$ -polarization is at  $\theta = 0^\circ$  and  $\phi = 0^\circ$  and  $\phi = \pm 180^\circ$  respectively. No radiation occurs in those directions where  $\phi = +90^\circ$  or where  $\theta = +90^\circ$ . The maximum of  $\theta$ -polarized radiation is found at  $\theta = +90^\circ$  and  $\theta = -90^\circ$ . No radiation exists at  $\theta = 0^\circ$  and  $\phi = 0^\circ$  or  $\phi = \pm 180^\circ$ .

The total field strength pattern has a minimum at  $\phi = 0^\circ$  and  $\phi = +180^\circ$ , when  $\theta = +90^\circ$ . Its maximum is at  $\phi = +90^\circ$ , and nearly independent of  $\theta$ .

Fig.21 to Fig.23 represent the same functions like Fig.18 to Fig.20, but are plotted as constant-field strength curves over the rectangular  $\phi$ - $\theta$ -plane.

The radiation patterns of antenna type 2 over the rectangular  $\phi$ - $\theta$ -plane, represented in a three-dimensional and a constant-field strength plot, respectively, are shown in Fig.24 to Fig.29.

The  $\phi$ -polarized electric field strength (Fig.24 and Fig.27) of this antenna is distributed similar to that of antenna type 1. The  $\theta$ -polarized field shows a maximum value for  $\phi = +90^\circ$ , which is nearly independent of the elevation. Zeros exist for  $\phi = 0^\circ$ ,  $180^\circ$  and  $360^\circ$ .

The total electrical field strength is found to be zero for  $\theta = +90^\circ$  and  $\phi = 0^\circ$ ,  $180^\circ$  and  $360^\circ$ . On this account wave propagation normal to the driving direction is not possible for both polarizations, if the elevation angle  $\theta$  is exactly  $\theta = 90^\circ$ . Therefore, in some unusual cases ground-wave communications might fail in a small angle range, while sky-wave communications is possible in any direction.

## 2.2 Radiation resistance

The power radiated from the antenna into the space can be calculated by integrating the power density over the radiation sphere:

$$P_r = \int S \cdot da \quad (17)$$

where:

$$da = R_o \cdot \sin\theta \cdot d\theta \cdot d\phi \quad (18)$$

As the antenna is initially assumed to be lossless, this radiated power has to be identical with the antenna input power:

TYPE 1

f = 3 MHz

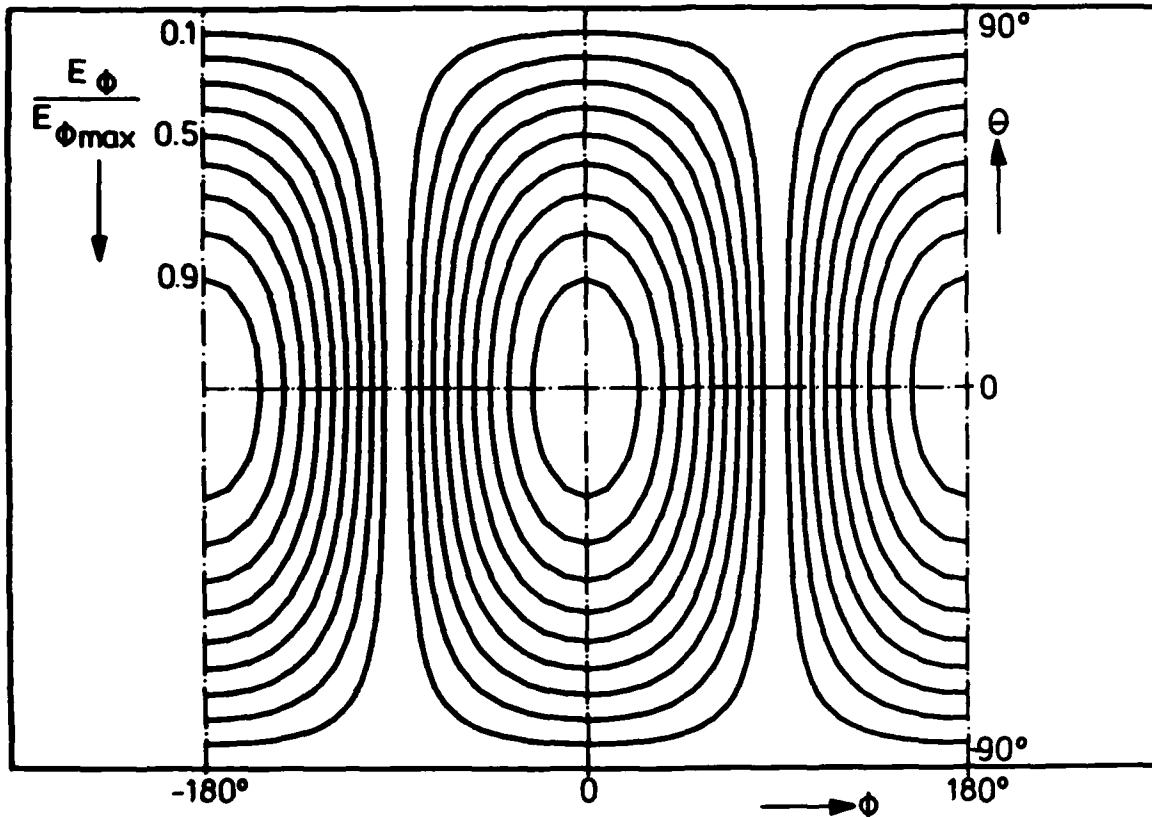

Fig. 21: Antenna type 1 - lines of constant electrical field strength over the rectangular  $\phi$ - $\theta$ -plane ( $\phi$ -polarization)

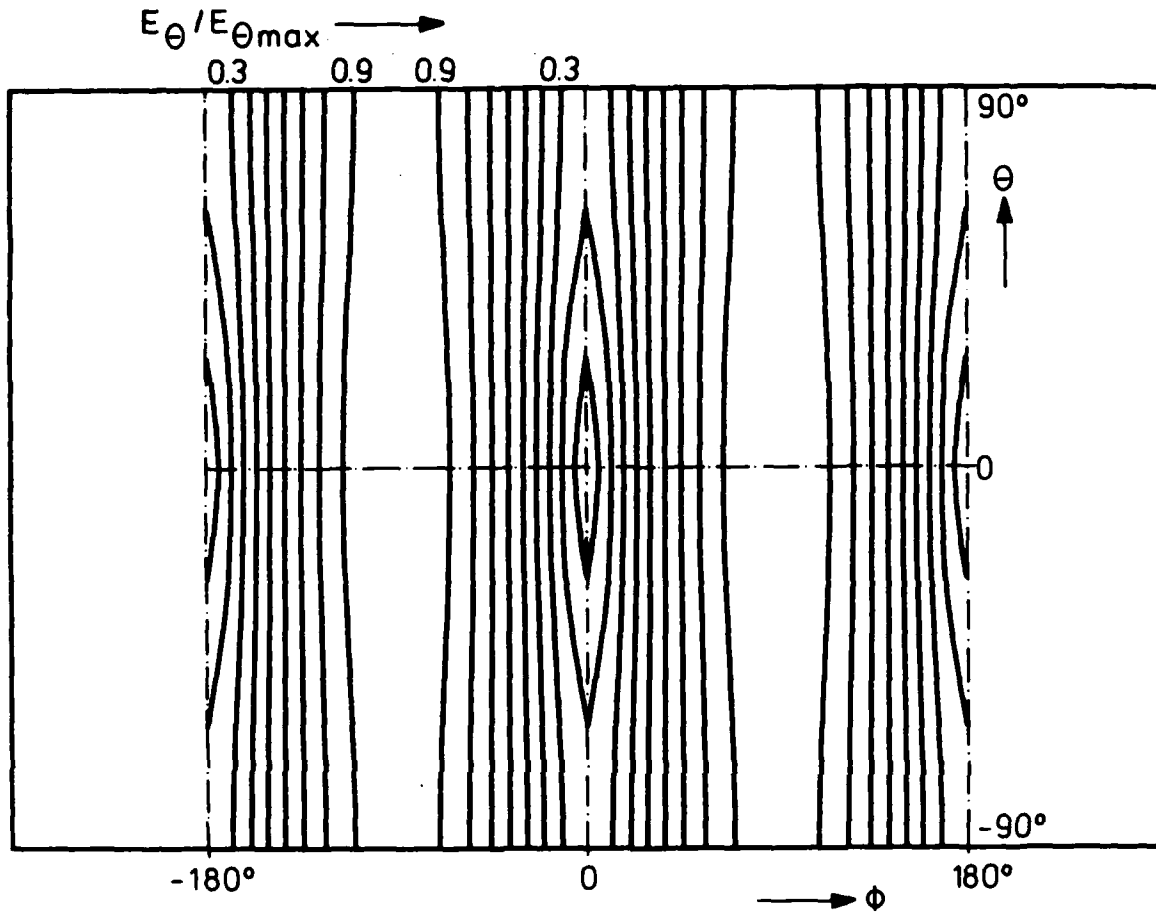
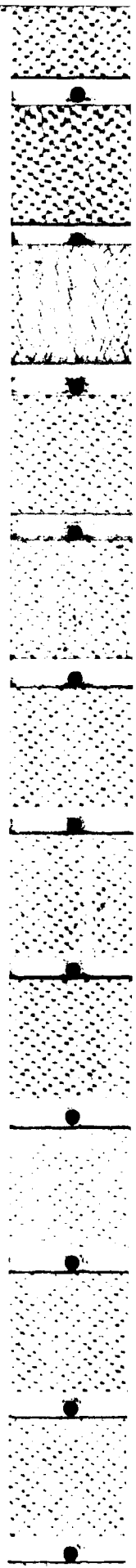

Fig. 22: Antenna type 1 - lines of constant electrical field strength over the rectangular  $\phi$ - $\theta$ -plane ( $\theta$ -polarization)



TYPE 1

f = 3 MHz

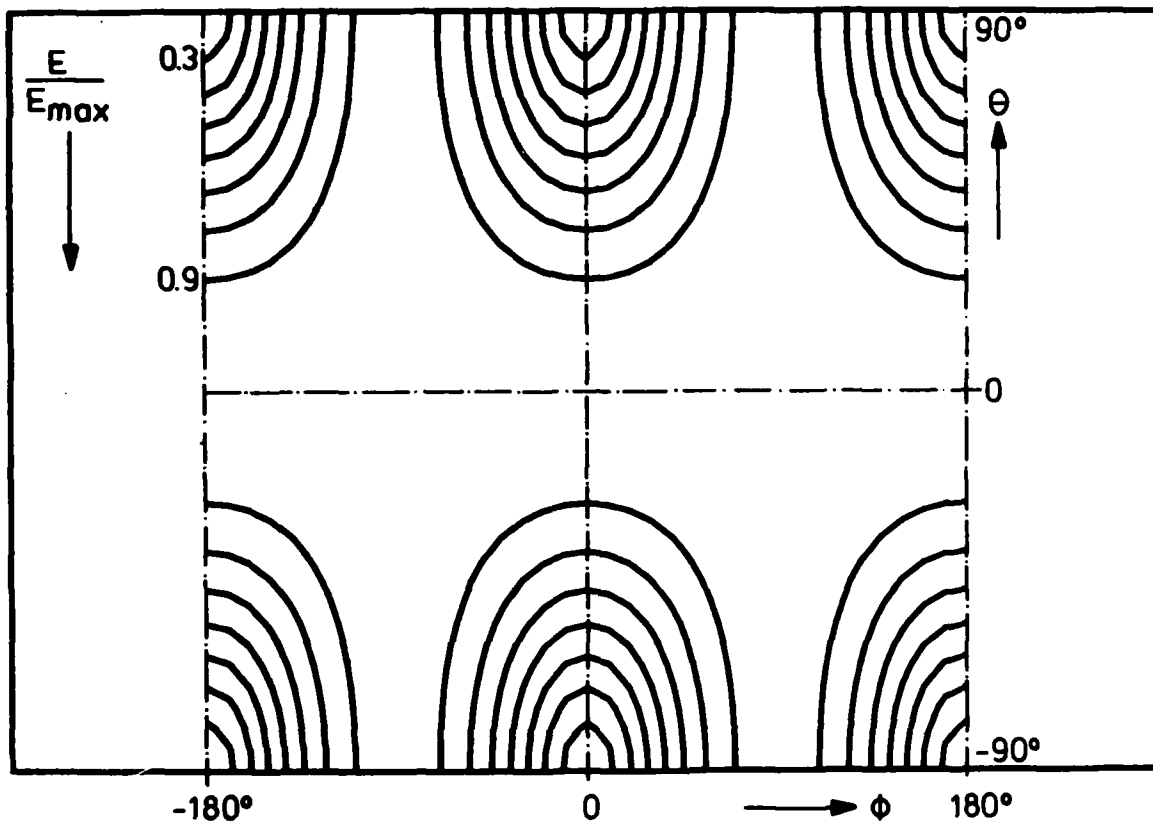

Fig. 23: Antenna type 1 - lines of constant total electrical field strength over the rectangular  $\phi$ - $\theta$ -plane

TYPE 2

f = 3 MHz

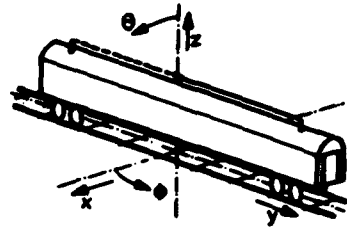
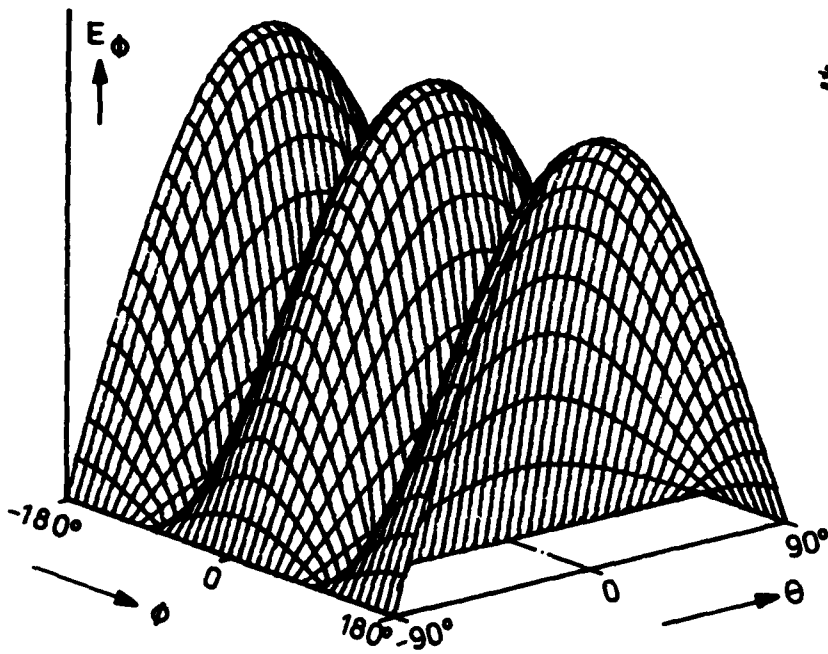

Fig. 24:  $\phi$ -polarized electrical field strength

TYPE 2

f = 3 MHz

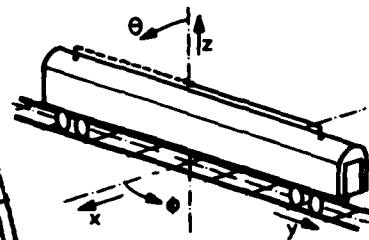
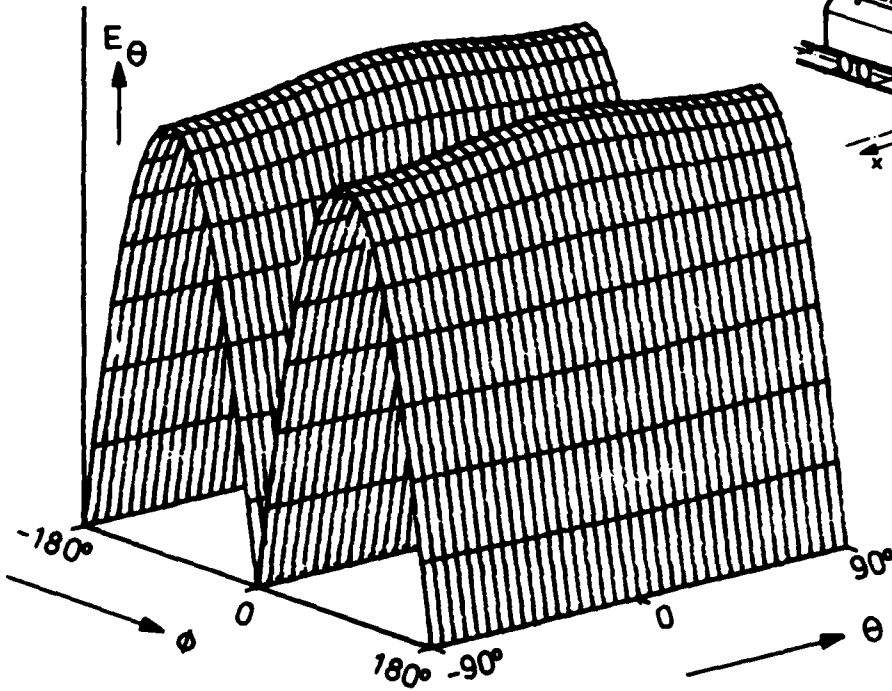
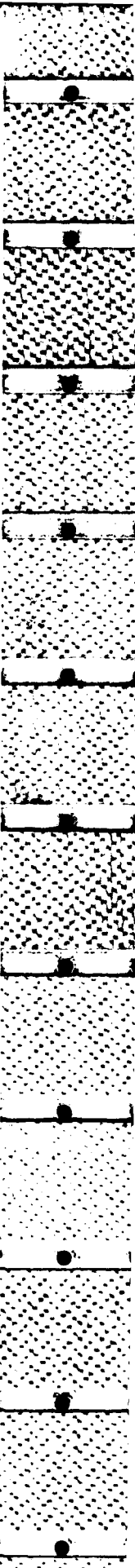

Fig. 25:  $\theta$ -polarized electrical field strength



TYPE 2

$f = 3\text{MHz}$

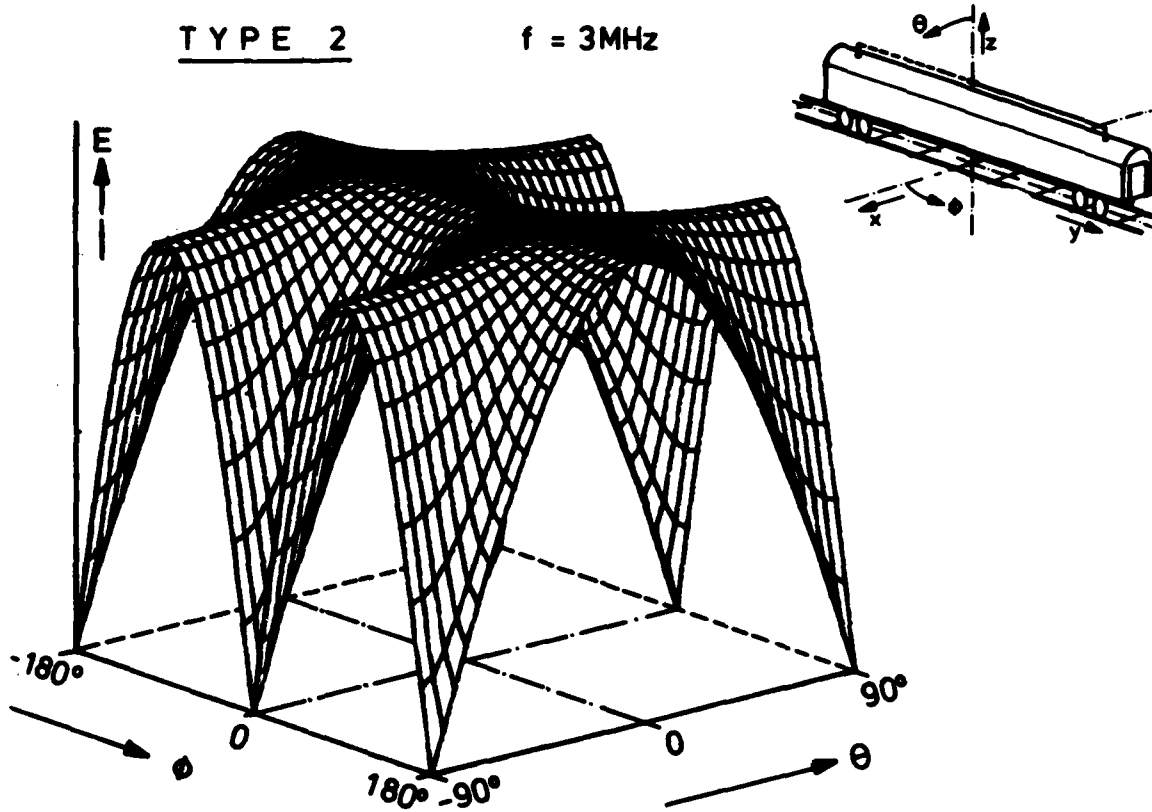

Fig. 26: Antenna type 2 - total electrical field strength over the rectangular  $\phi$ - $\theta$ -plane

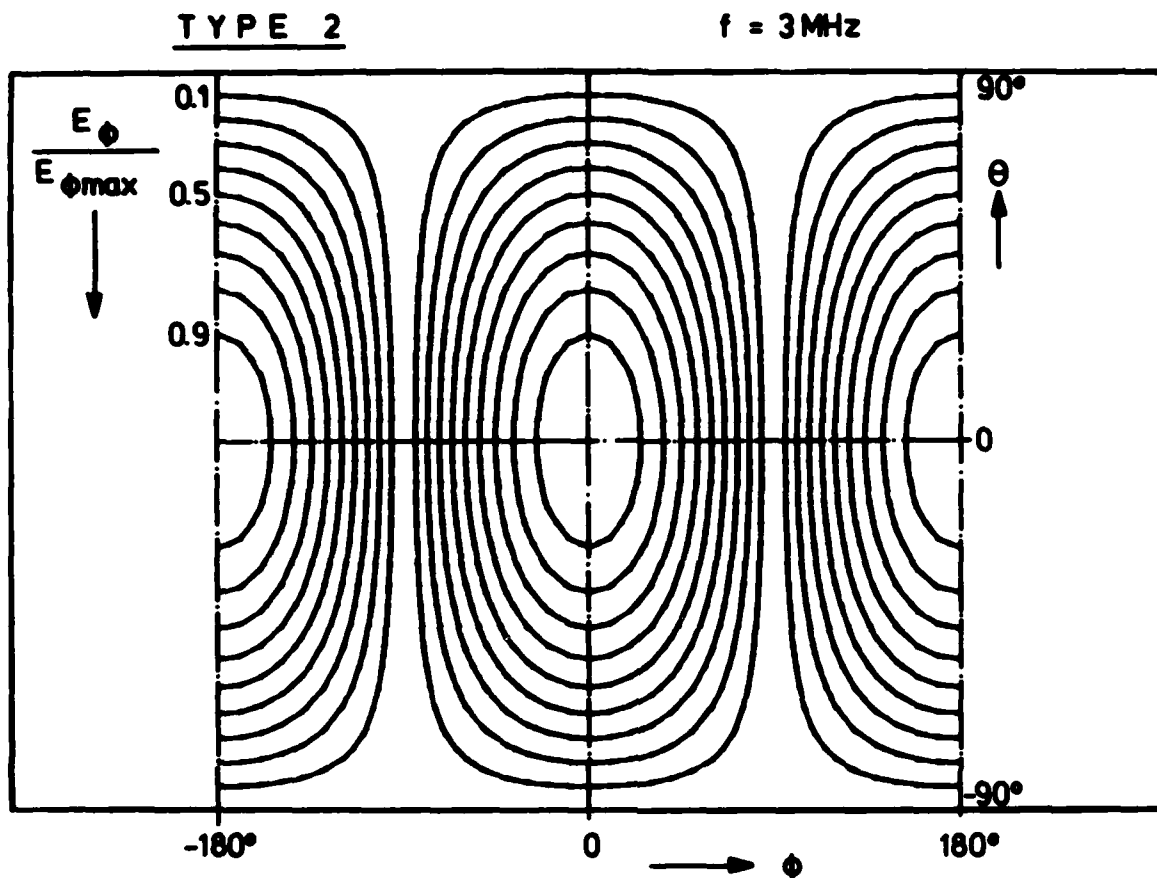

Fig. 27: Antenna type 2 - lines of constant electrical field strength over the rectangular  $\phi$ - $\theta$ -plane ( $\phi$ -polarization)

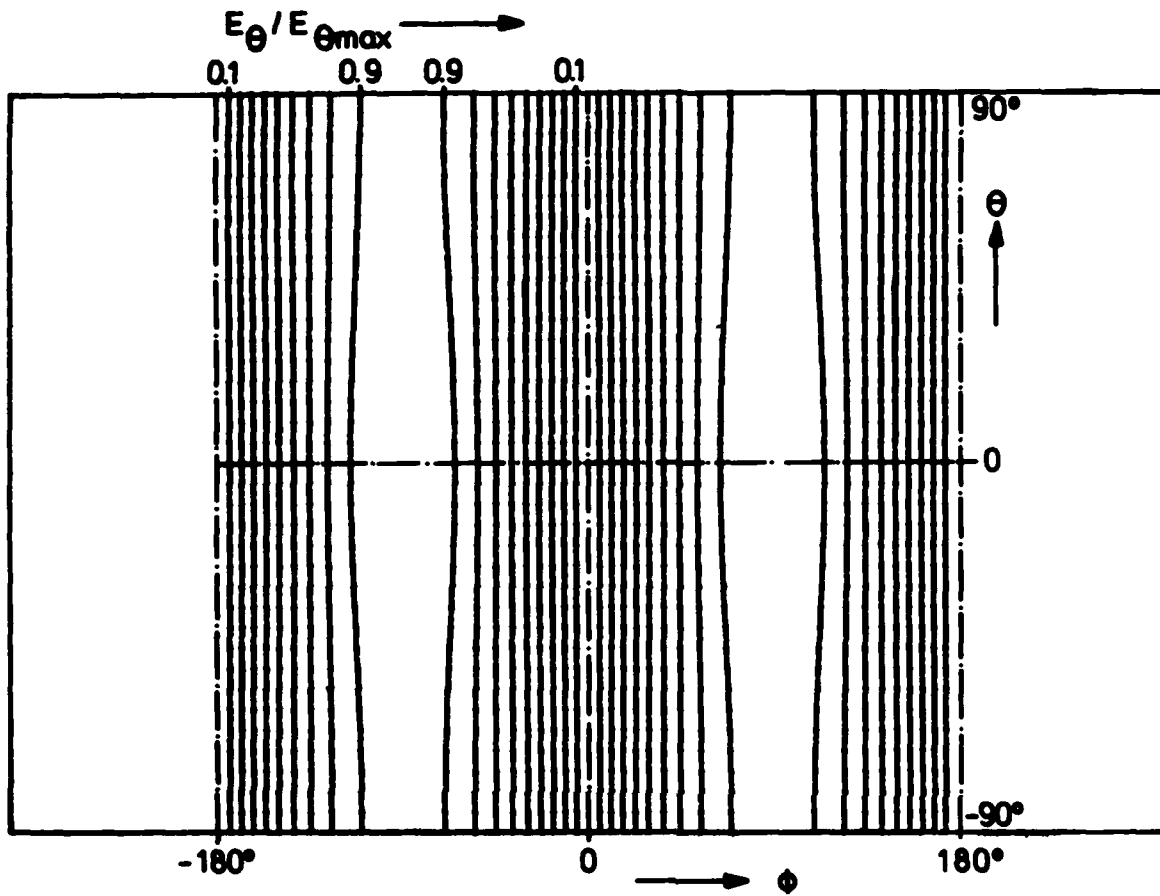

Fig. 28: Antenna type 2 - lines of constant electrical field strength over the rectangular  $\phi$ - $\theta$ -plane ( $\theta$ -polarization)

TYPE 2

f = 3MHz

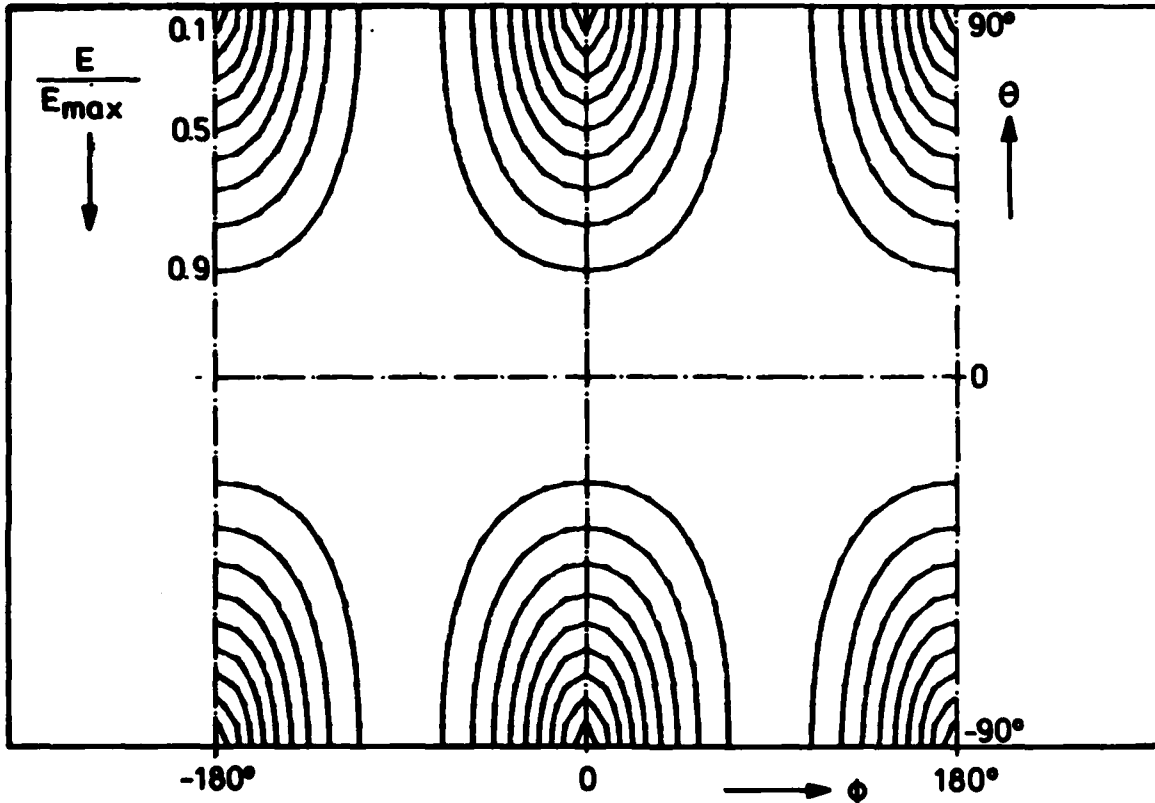

Fig. 29: Antenna type 2 - lines of constant total electrical field strength over the rectangular  $\phi$ - $\theta$ -plane

$$P_r = \frac{1}{2} \cdot |\underline{I}(o)|^2 \cdot R_{rs} \quad (19)$$

where  $R_{rs}$  is the unknown radiation resistance of the antenna, or in other words, the real part of the antenna impedance without losses. To make the integral of eq.17 applicable for a digital computer it is changed to a sum. In this case the radiation resistance can be written as:

$$R_{rs} = \frac{R_o^2}{|\underline{I}(o)|^2 \cdot Z_i} \cdot \sum_{\phi_j=0}^{\phi_j=2\pi} \cdot \sum_{\theta_i=0}^{\theta_i=\pi} (E^2 \cdot \sin\theta_i \Delta\theta) \cdot \Delta\phi \quad (20)$$

where:  $\phi_j = \phi_{j-1} + \Delta\phi$

and:  $\theta_i = \theta_{i-1} + \Delta\theta$

This radiation resistance would occur if a symmetric antenna configuration as shown in Fig.4 would be used. As the lower part of the antenna is only the image of the real antenna, the radiation resistance  $R$  of this real antenna, radiating only into the upper half-sphere is half the resistance of the symmetric configuration:

$$R_r = \frac{1}{2} \cdot R_{rs} \quad (21)$$

Although the boundaries in eq.20 can become smaller because of the symmetry of  $E(\phi, \theta)$ , the computer takes a lot of time to calculate  $R_r$ . If the whole antenna circuit shall be optimized, the calculation of  $R_r$  will increase the optimization procedure in an unjustifiable manner. Because of this - beside the numerical integration of eq.20 - an approximation for evaluating  $R_r$  has been used:

Antenna type 1 radiates in the total half-sphere, nearly like a half-wavelength dipole with its axis in the x-direction. The field strength of the far-field is given by eq.11 and eq.9, respectively, and is assumed to be approximately zero in those directions, where actually the minimum radiation occurs. This assumption seems to be quite rough, as for example at 4MHz the field strength for  $\phi = 0^\circ$  and  $\phi = 180^\circ$  is still about half the maximum field strength of  $\phi = \pm 90^\circ$ . But as the radiation resistance is in the milliohm range, this error will be negligible against the errors of estimating contact resistances or surface roughness, e.g.

The maximum electric field strength in the far-field of antenna type 1 is:

$$E_{max} = |\underline{I}(o)| \cdot Z_i \frac{h}{R_o \cdot \lambda_o} \cdot \tan(\beta_o \cdot a) \quad (22)$$

With the assumption of no radiation in the directions  $\phi = 0^\circ$  and  $\phi = +180^\circ$  the integration of the average Poynting vector over the radiation sphere leads to:

$$R_r \approx \frac{4}{3} \cdot \pi \cdot Z_i \cdot \left[ \frac{h \cdot \tan(\beta_o \cdot a)}{\lambda_o} \right]^2 \quad (22a)$$

This equation can be modified to a more convenient formula:

$$R_r \approx 17.5 \Omega \cdot \left[ \frac{h}{[m]} \cdot \frac{f}{[MHz]} \cdot \tan(\beta_o \cdot a) \right]^2 \quad (22b)$$

At lower frequencies this result fits quite well with the numerical solution of eq.20 (see Fig.30 and Fig.31).

The radiation pattern of antenna type 2 is almost identical to that of a half-wavelength dipole with its axis in the x-direction. The maximum field strength in the far-field region can be found, using eq.13 and eq.9:

$$E_{\max} = |I(o)| \cdot Z_i \cdot \frac{2 \cdot h}{R_o \cdot \lambda_o} \cdot \tan(\beta_o \cdot a) \quad (23)$$

The integration of the average Poynting vector over the radiation sphere leads to:

$$R_r \approx \frac{16}{3} \cdot \pi \cdot Z_i \cdot \left[ \frac{h \cdot \tan(\beta_o \cdot a)}{\lambda_o} \right]^2 \quad (24)$$

and can also be modified to a more convenient equation:

$$R_r \approx 70 \Omega \cdot \left[ \frac{h}{[m]} \cdot \frac{f}{[MHz]} \cdot \tan(\beta_o \cdot a) \right]^2 \quad (24a)$$

The dependence of  $R_r$  from height and length of the antenna and from the frequency is shown in Fig.32 and Fig.33. The results correspond well with the numerical solution of eq.20.

For both antennas, the dependence of the radiation resistance on height, frequency and length is described by a square law. The approximations which have been used limit the application of the formulas to a length which is smaller than a quarter wavelength.

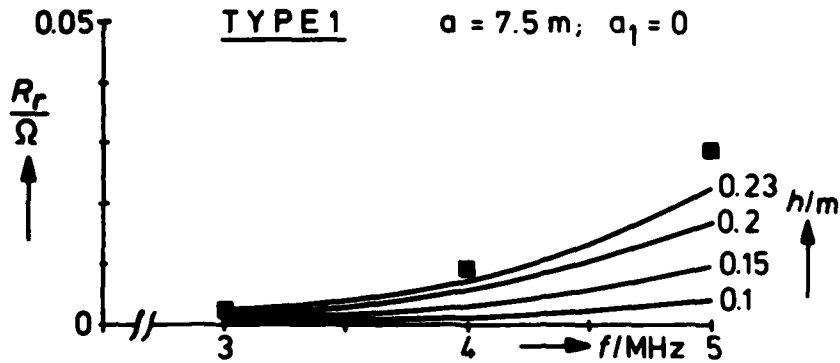

Fig. 30: Calculated radiation resistance of antenna type 1, depending on the frequency  $f$  and the height  $h$  of the current filament  $I$ .

■: result of numerical integration ( $h = 0.23$ )  
Solid lines: approximation (eq. 22)

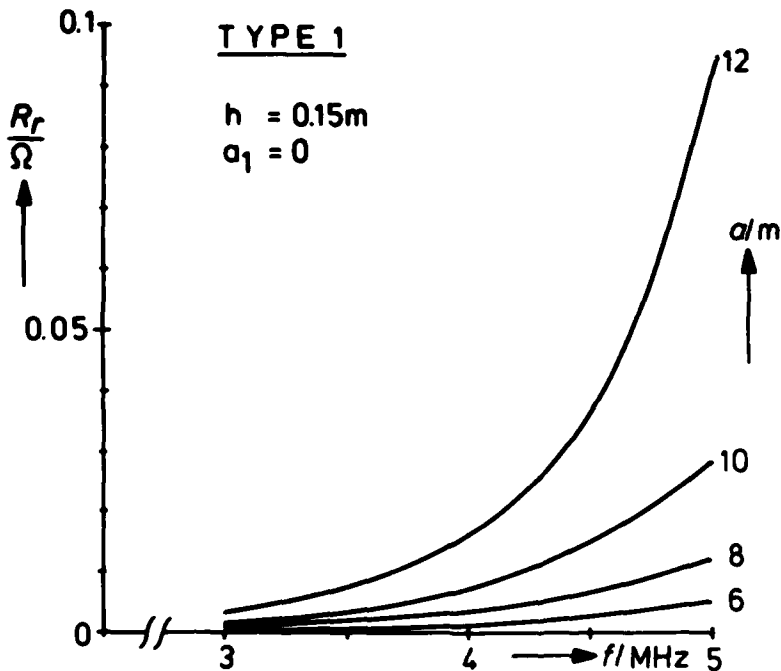

Fig. 31: Calculated radiation resistance of antenna type 1, depending on the frequency  $f$  and the length  $a$  of the antenna elements (approximation)

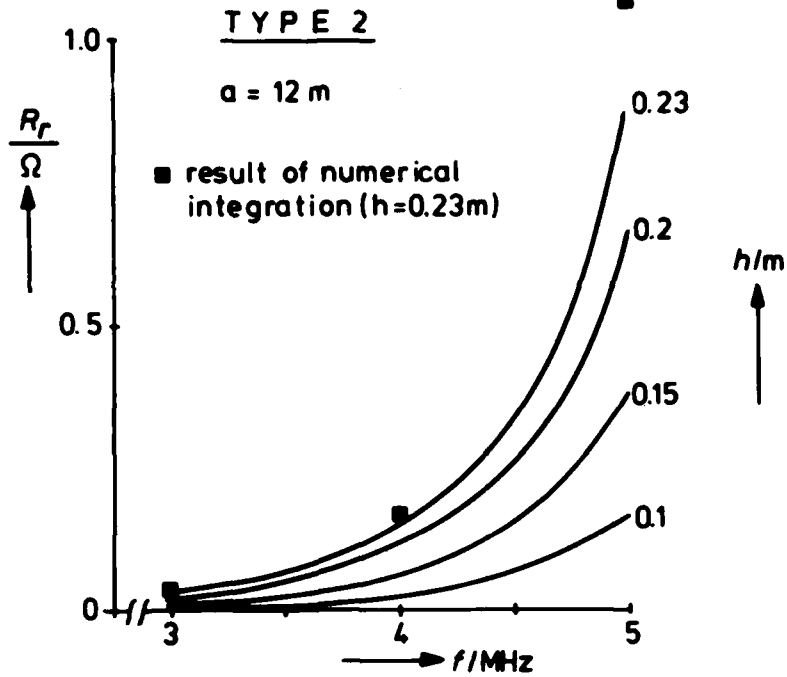

Fig. 32: Calculated radiation resistance of antenna type 2, depending on the frequency  $f$  and the height  $h$  of the current filament I (approximation)

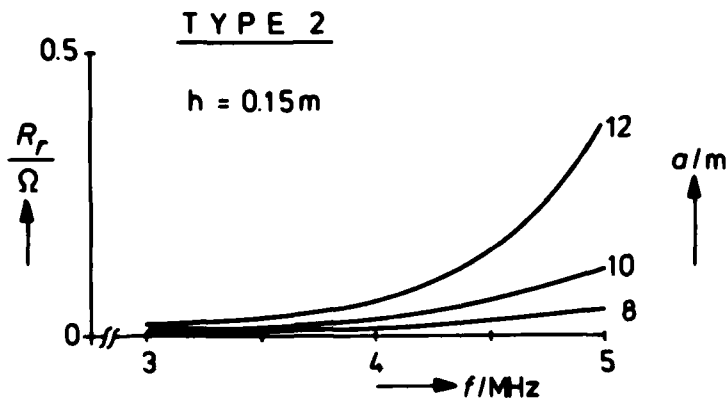

Fig. 33: Calculated radiation resistance of antenna type 2, depending on the frequency  $f$  and the length  $a$  of the antenna elements (approximation)

Since eq.22 is very similar to eq.24, both resistances can be compared if height and length are identical. Calling the resistance of antenna type 1 " $R_{r1}$ " and that of antenna type 2 " $R_{r2}$ ", the quotient of both is

$$\frac{R_{r2}}{R_{r1}} \approx 4 \quad (25)$$

This result is quite reasonable as the area of antenna type 2 is two times the area of antenna type 1 and as the radiation resistance of electrical small loop antennas depends on the square of the area. With fixed element length of antenna type 1 and variable length  $a$  of antenna type 2 the ratio of the radiation resistances of the two antennas is shown in Fig.34.

### 2.3 Imaginary part of the antenna impedance

If the length  $a$  of the antenna elements is smaller than a quarter wavelength, the radiation resistance will be significantly smaller than the imaginary part of the antenna impedance. The imaginary part of the antenna impedance therefore is approximately that of a shortened lossless line. For antenna type 1 one obtains:

$$\begin{aligned} \underline{Z}_{A1} &= R_{r1} + j \cdot X_{A1} \\ &\approx R_{r1} + j \cdot Z_0 \cdot \tan(\beta_0 \cdot a) \end{aligned} \quad (26)$$

Antenna type 2 consists of two identical lines in series. Therefore the impedance of this antenna becomes:

$$\begin{aligned} \underline{Z}_{A2} &= R_{r2} + j \cdot X_{A2} \\ &\approx R_{r2} + j \cdot 2 \cdot Z_0 \cdot \tan(\beta_0 \cdot a) \end{aligned}$$

The characteristic impedance  $Z_0$  of the line depends on the diameter  $d$  of the antenna elements. For a single element it is:

$$Z_{0s} = 60\Omega \cdot \ln\left[2 \cdot \frac{h + h_{\max}}{d} - 1\right]$$

Each tested antenna consisted of three elements in parallel. The resulting characteristic impedance of  $n$  conductors in parallel is usually not  $Z_{0s}/n$ , as the fields of the parallel lines are not independent. For evaluating the characteristic impedance of the antenna elements in parallel a graphic method and an antenna model at higher frequencies has been used.

The ratio of the three-element line impedance  $Z_0$  and the single

TYPE 1 with fixed a

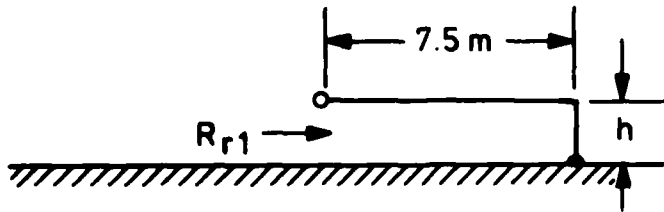

TYPE 2 with variable a

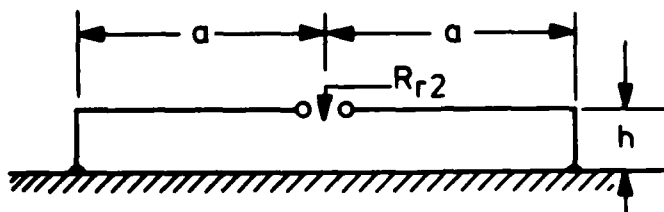

a) Antenna configurations

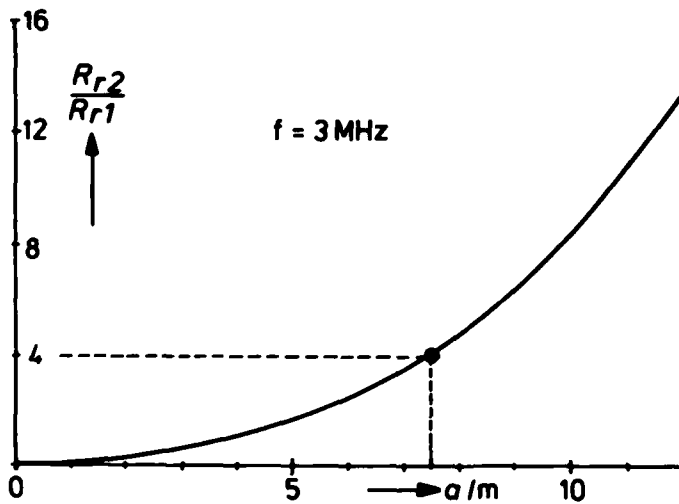

b) Relation of the radiation resistances versus element length of antenna type 2

Fig. 34: Comparison of the radiation resistances of antenna type 1 and type 2, if length a of antenna type 1 is fixed

element characteristic impedance  $Z_{os}$  depends approximately only on the distance  $b$  of the elements if the outlines of the antenna are not changed (see Fig.35). The ratio has to be unique, if  $b/h$  approaches zero, as the line then becomes a single element line. If  $b$  is much greater than the height  $h$  of the current filament, the fields of the lines will become independent and the ratio  $Z_o/Z_{os}$  will approach  $Z_o/Z_{os} = 1/3$ . A sufficient approximation has been found by use of the equation:

$$\frac{Z_o}{Z_{os}} \approx \frac{1}{3} \cdot [1 + 2 \cdot \exp(-0.7 \cdot \frac{b}{h})] \quad (29)$$

This approximation will fail, if the feeding point is chosen close to one antenna element while the other two elements are connected via a longer conductor, representing a serial inductance which cannot be neglected at higher frequencies.

The far-field of the three-element antenna does not differ from that of the single element antenna, as the currents in the antenna elements have the same direction each and the path difference  $\Delta$  is small, compared to the wavelength  $\lambda_o$ .

In the realized version, antenna type 1 consists not only of a shortened line but also of an open-ended part of the length  $a_1 = 1.5m$  (see Fig.1). As this open line is shorter than a quarter wavelength it acts as a capacitor in parallel to the feeding point. The current into this line is very small compared to the current into the shortened line and can be neglected for the calculation of the far-field. For the evaluation of the antenna's imaginary part, however, it has to be taken into account. Therefore, the imaginary part of the antenna impedance of type 1 becomes:

$$X_{A1} = Z_o \cdot \frac{\tan(\beta_o \cdot a)}{1 - \tan(\beta_o \cdot a) \cdot \tan(\beta_o \cdot a_1)} \quad (30)$$

#### 2.4 Losses

The losses of the antenna are caused by:

- the contact resistances between coupler and antenna
- the serial resistance of the antenna element, which is determined by inhomogenous current distribution, skin effect, and roughness of the conductor surface. All of these parameters are increased by corrosion
- the contact resistances of the grounding strips

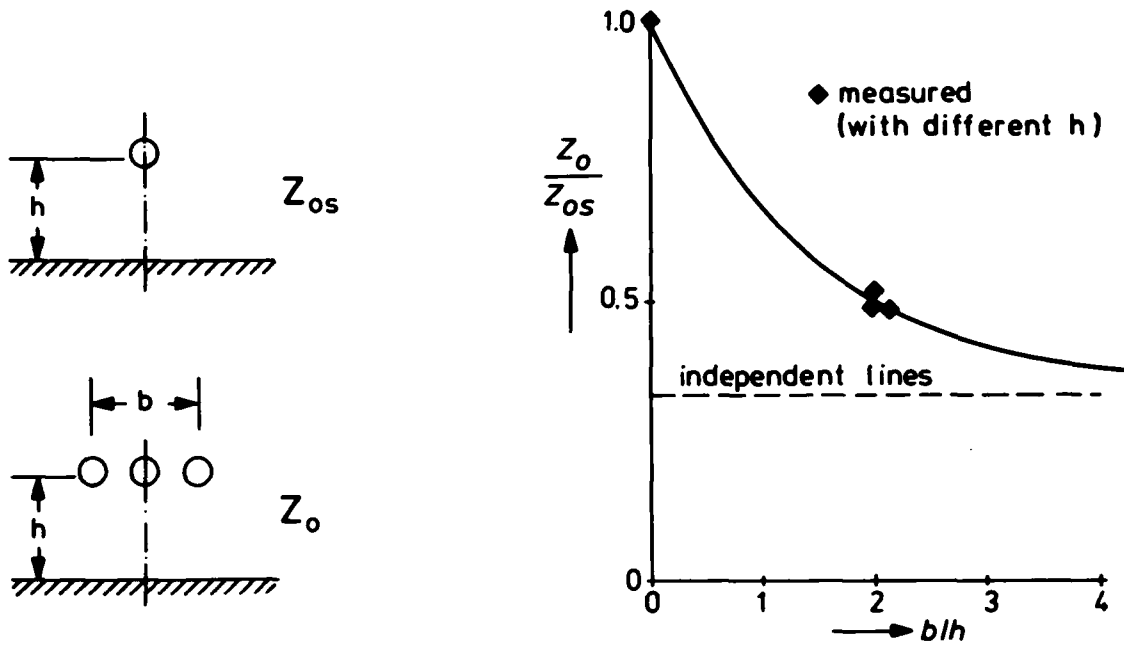

Fig. 35: Characteristic impedance  $Z_o$  of a 3-element line, compared to the impedance  $Z_{os}$  of a single element line

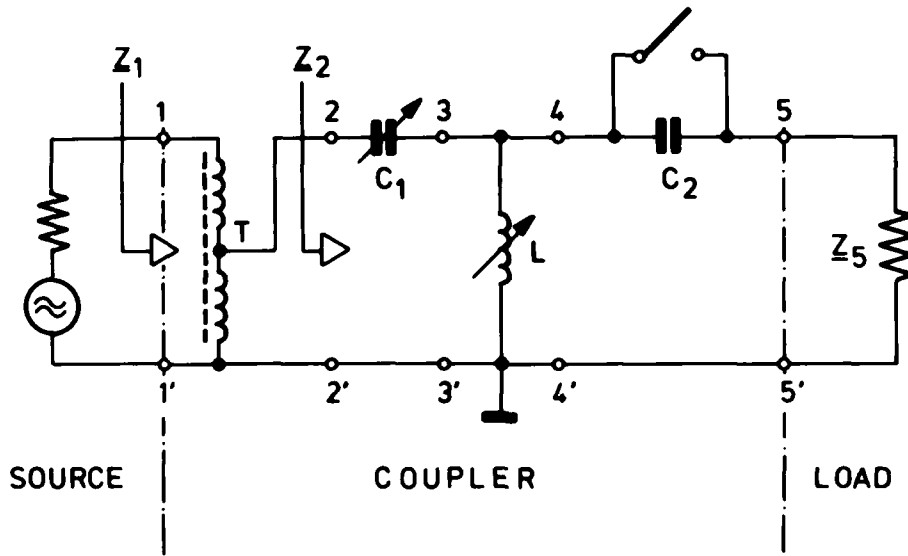

Fig. 36: Rf-circuit diagram of the HARRIS-antenna coupler RF615B

- the parallel resistances of the insulators between antenna and roof, when covered with coal particles, dust or dirty water
- the parallel resistance over the total antenna length, when snow and ice, mixed with dirt, covers the roof.

Most of the presented losses can only be estimated and will change with aging, weather conditions, corrosion, and maintenance. For the calculation of the antenna efficiency the best values that can be obtained have been used.

The connection between coupler and antenna has to be made of a material with low losses and a low propensity for corrosion. The contacts, coupler-connector and connector-antenna, should be protected against wetness to avoid electro-chemical corrosion. Under these conditions a resistance of about  $R_c \approx 20m\Omega$  for each contact seems to be reasonable. The power loss caused by these resistances depends on the input current  $I(0)$  of the antenna and is for each contact:

$$P_{L1} = \frac{1}{2} \cdot |I(0)|^2 \cdot R_c \quad (31)$$

The loss caused by the finite conductivity of the antenna elements can only be found by integrating the differential losses over the total antenna length, as the current density is a function of  $y$  (see eq.2). The total loss of one antenna element can be substituted by a serial resistance, located at the antenna's feeding point. As there are three elements connected in parallel, the total resistance  $R$  is one third of the resistance of a single element and becomes:

$$R_a = \frac{1}{3} \cdot \frac{R'}{\cos^2(\beta_0 \cdot a)} \cdot \int_{y=0}^{y=a} \cos^2[\beta_0 \cdot (a-y)] \cdot dy \quad (32)$$

$$= \frac{1}{6} \cdot R' \cdot a \cdot \frac{2 \cdot \beta_0 \cdot a + \sin(2 \cdot \beta_0 \cdot a)}{2 \cdot \beta_0 \cdot a + \cos^2(2 \cdot \beta_0 \cdot a)}$$

where  $R'$  is the surface resistance of the antenna element

$$R' = \frac{2 \cdot h_{\max} - d}{2 \cdot h \cdot d} \cdot \sqrt{\frac{f \cdot \mu}{\sigma \cdot \pi}} \quad (33)$$

( $\mu$  = permittivity of antenna element and roof  
 $\sigma$  = conductivity of antenna element and roof)

If the surface of the conductors is rugged, the resistance will grow with the factor  $F_R$ :

$$R'' = R' \cdot F_R$$

$$F_R = 1 + \frac{2}{\pi} \cdot \arctan\left[1.4 \cdot \left(\frac{\Delta r}{\delta}\right)^2\right] \quad (34)$$

where  $\Delta r$  is the RMS-value of the surface ruggedness and  $\delta$  is the penetration depth:

$$\delta = \frac{1}{\sqrt{\pi \cdot f \cdot \sigma \cdot \mu}} \quad (35)$$

The imaginary part of the surface resistance can be neglected against the imaginary part of the short circuited line.

The dissipative power, caused by the finite conductivity of the antenna element is:

$$P_{La} = \frac{1}{2} \cdot |I(o)|^2 \cdot R_a$$

The contact resistance of the grounding strips strongly influences the total efficiency since the antenna current has a maximum at the short. The strips have to be as short as possible and should be soldered and protected against wetness and corrosion. Only if the short is connected very carefully in the way described before, can the contact losses be neglected at this point.

If the insulators which bear the antenna elements at the roof are clean, no parallel losses will occur. If the insulators are covered with some conducting deposits, for example from the exhaust fumes of the engine, the losses will depend on the position of the insulator, the length of the insulating gap, the cross-section of the conducting cover, and on its conductivity. To avoid this kind of loss the insulator gap has to be as broad as possible, protected by a shield and cleaned at certain time intervals.

As the antenna height is very small, snow and ice mixed with conducting particles may decrease the efficiency of the antenna. In these cases the roof has to be cleaned.

## 2.5 Problems

With the results of the antenna calculation, it is possible to estimate the voltages and currents, which occur at the antenna. For a radiated power of only 2 Watts with antenna type 1, a current with the magnitude of  $I(0) = 17,5A$  and a voltage of  $U(0) = 1.29kV$  is necessary, as the phase angle between voltage and current is close to  $90^\circ$ !

Because of the high currents, nonlinear effects such as the generation of harmonics as well as intermodulation may occur at the connections of the antenna elements.

## 3. Transmission Line

When the antenna has been successfully tuned, the transmission line between coupler and transmitter will be connected to a matched load. Because of this and the small length of the line, the losses are small too.

Antenna type 2 uses a second transmission line between the coupler and the symmetric feeding point which actually transforms the antenna impedance. Since the current at the feeding point has to be very high, the serial cable losses will not be negligible. The following calculations apply to antenna type 2 only.

### 3.1 Losses of the coaxial feeder line.

The coaxial feeder line should be filled with air and have only a few dielectric supports. On this account, the losses caused by the electric field are negligible. The current density is nonhomogenous as the magnitude of the antenna's reflection coefficient is very close to 1. The total loss of the coaxial line can be evaluated by integrating the differential serial losses over the full length of the line. The total loss can be substituted by a serial resistance  $R_{LC}$ , which is very small compared to the imaginary part of the antenna impedance. This fictitious loss resistance is located at the symmetrical feeding point:

$$R_{LC} = \frac{R'_c}{\cos^2\left(2 \cdot \pi \cdot \frac{l_0}{\lambda \epsilon}\right)} \cdot \int_{z=l_0}^{z=l_0+l_T} \cos^2\left(2 \cdot \pi \cdot \frac{z}{\lambda \epsilon}\right) \cdot dz \quad (37)$$

where:  $R'_c$  = surface resistance of the coaxial line:

$$R'_c = \left(\frac{1}{D_a} + \frac{1}{D_i}\right) \cdot \sqrt{\frac{f \cdot \mu_0}{\pi \cdot \sigma}}$$

$D_a$  = inner diameter of outer conductor  
 $D_i$  = outer diameter of inner conductor  
 $l_o$  = length of a hypothetical coaxial line, short circuited  
 and with the same characteristic impedance  $Z_o$  as  
 the feeder line and the same input impedance as  
 the antenna (real part neglected)

$$l_o = \frac{\lambda_\epsilon}{2 \cdot \pi} \cdot \arctan(X_{A2}/Z_o) \quad (39)$$

$$Z_o = 60\Omega \cdot \ln(D_a/D_i)$$

$l_T$  = mechanical length of coaxial line = length  $a$  of antenna element

The wavelength  $\lambda_\epsilon$  at the coaxial line is very close to the free-space wavelength, as the dielectric supports do not appreciably change the phase velocity.

The solution of the integral leads to:

$$R_{LC} = R'_c \cdot \lambda_\epsilon \cdot \frac{4\pi \cdot \frac{l_T}{\lambda_\epsilon} - \sin(4\pi \cdot \frac{l_o}{\lambda_\epsilon}) + \sin(4\pi \cdot \frac{l_o + l_T}{\lambda_\epsilon})}{8 \cdot \pi \cdot \cos^2(2\pi \cdot \frac{l_o}{\lambda_\epsilon})} \quad (41)$$

### 3.2 Transformation of the coaxial line

The radiation resistance and the loss resistance of the antenna as well as the contact resistances and the loss resistance of the coaxial line had been transformed to serial resistances located at the balanced feeding point of the antenna. The summed-up resistances are still much smaller than the imaginary part  $X_{A2}$  of the antenna impedance:

$$\underline{Z}_6 = (R_{r2} + R_a + R_c + R_{LC}) + jX_{A2} \quad (42)$$

The coaxial line which now theoretically is assumed to be lossless, as its losses are represented by the resistance  $R_{LC}$ , transforms the impedance  $\underline{Z}_6$  to the impedance  $\underline{Z}_5$ :

$$\underline{Z}_5 = \frac{\underline{Z}_6 + jZ_o \cdot \tan(2\pi \cdot \frac{l_T}{\lambda_\epsilon})}{1 + j\frac{\underline{Z}_6}{Z_o} \cdot \tan(2\pi \cdot \frac{l_T}{\lambda_\epsilon})} \quad (43)$$

#### 4. Antenna Coupler (HARRIS RF615B)

##### 4.1 Circuit diagram and functions

The RF-circuit diagram of the antenna coupler is shown in Fig.36. The impedance  $Z_5$  has to be transformed to an impedance of  $Z_1 = 50\Omega$ . The antenna matching will be accepted by the coupler, as soon as the standing wave ratio at pins 1-1' is not greater than  $SWR = 2$ . Otherwise, the transmitter automatically will be connected to a dummy-load and an "overload" will be indicated. Capacitor  $C_1$  and inductance  $L$  are motor controlled. Capacitor  $C_2$  can be short-circuited by a relay. The tuning is done automatically by help of two discriminators in less than five seconds.

The transformer  $T$  has a voltage ratio of 2 and transforms the source-impedance of 50 Ohms at pins 1-1' to a source-impedance of 12.5 Ohms at pins 2-2'. The matching condition is:

$$Z_2 = 12.5\Omega$$

The losses of the toroid are usually negligible.

##### 4.2 Losses of the coupler elements

Capacitor  $C_1$  is a vacuum type which can be varied between 12pF and 500pF. The losses caused by the electric field are negligible, but there are serial losses caused by the current, especially at the rotor contact. These losses have been substituted with a 20-Milliohm serial resistance (see Fig.37).

The variable coil is a cylindrical inductor, the unused part of which is short-circuited. The tuning range of the inductance  $L$  has been assumed to be  $1\mu H \leq L \leq 50\mu H$ . The Q-factor  $Q$  of the coil depends on the serial resistance of the rotor contact, the losses of the magnetic field, the losses caused by the current, including skin effect and proximity effect and losses from the coupling of the shortened part of the coil and the part in use. This coupling effect usually shows maximum values at some resonant frequencies.

As known from several different couplers the Q-factor varies with the tuning position and the frequency. The dependence of the Q-factor from the rotor position and the frequency was assumed to be:

$$Q_L = Q_0 \cdot \sqrt{\frac{L}{L_{\max}} \cdot \frac{f}{f_{\max}}} \quad (44)$$

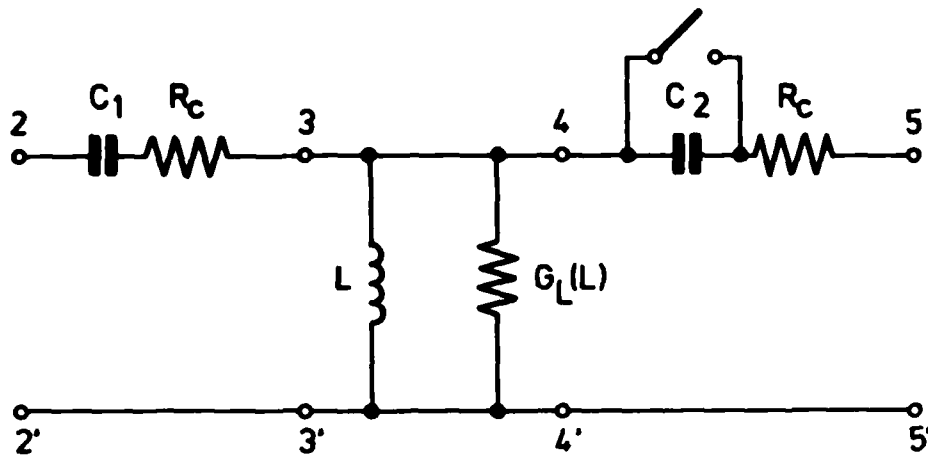

Fig. 37: Circuit diagram of the coupler between Pins 2-2' and 5-5' including loss resistances

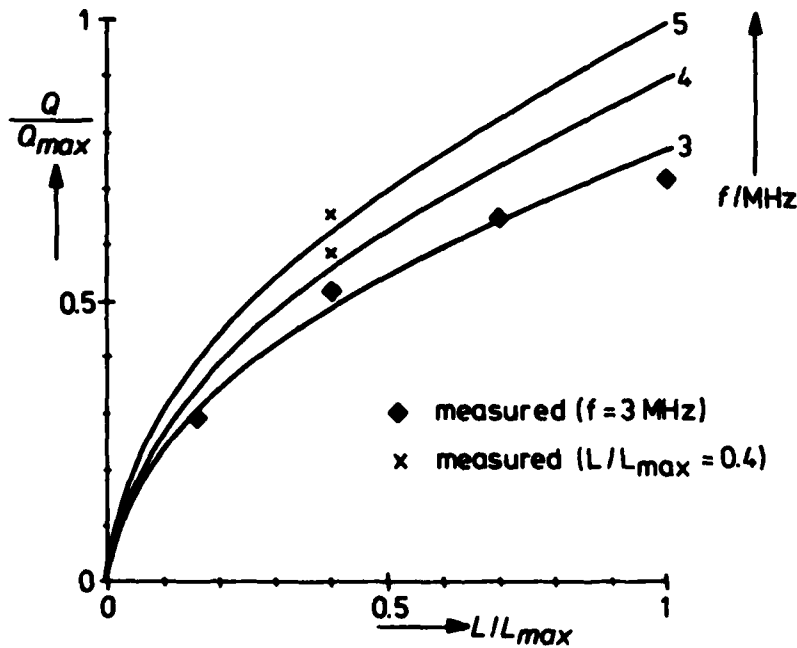

Fig. 38: Q-factor of the variable inductor  $L$  versus inductance. Parameter: frequency  $f$ . solid lines: approximation (eq. 44)

where  $Q_0$  was estimated to be  $Q_0 = 380$  with  $L_{\max} = 50\mu\text{H}$  and  $f_{\max} = 5\text{MHz}$ . Eq.44 is quite reasonable, as the length of the coiled wire increases with the number  $w$  of turns, while the inductivity increases with  $w^2$ . Furthermore, the reactive power increases linearly with the frequency, while the losses, caused by the skin effect, increase with  $\sqrt{f}$ :

$$\left. \begin{aligned} P_{\text{reactive}} &\sim f \cdot L \\ P_{\text{loss}} &\sim w \cdot \sqrt{f} \\ w &\sim \sqrt{L} \\ Q_L = P_{\text{reactive}}/P_{\text{loss}} \end{aligned} \right\} Q_L \sim \sqrt{L \cdot f}$$

Fig.38 shows the dependance of the inductor's Q-factor from the frequency and the inductivity. The solid lines are the result of eq.44. The measurement results documented in this diagram have been achieved with a variable coil used in one of the investigated couplers.

The conductance  $G_L$ , representing the losses of the coil, can be calculated using eq.45:

$$G_L = \frac{1}{\omega \cdot L \cdot Q_L} \quad (45)$$

The capacitor  $C_2$  is a fixed ceramic capacitor (200pF) which can be by-passed by a relay contact. The losses of this capacitor and the contact resistance have been substituted by a serial resistor of  $R_c = 20$  Milliohms.

The values estimated for the coupler's elements may vary widely, because of a damaged rotor or relay contact. The reliability of the estimations of the coupler losses can only be verified by comparision of the calculated and measured total efficiency of the antenna configuration, including the coupler.

#### 4.3 Calculation of the coupler transformation

The computer program which has been used works similar to the coupler function. With the relay contact in parallel to  $C_2$ , open and closed respectively, the inductivity  $L$  is varied in small steps. For each value of  $L$ , the variable capacitor  $C_1$  is tuned, if possible, to a value, where the imaginary part of  $Z_2$  is as close as possible to zero. The impedance  $Z_2$  is then transformed

to the input impedance  $\underline{Z}_1$ . With this impedance the standing wave ratio is calculated. If  $SWR \leq 2$ , the currents, voltages, and powers of the antenna, the coaxial line, and the coupler is computed.

(The matching procedure can also be done by solving a 6-th order polynomial. This method has been tested too, but the step-by-step method described before can be supervised much easier and doesn't take much time. So we preferred this way).

The computation will now be described in more detail:

The impedance  $\underline{Z}_4$ , is, depending on the relay contact

$$\underline{Z}_4 = \underline{Z}_5 + R_c + \begin{cases} 0 & \text{(contact closed)} \\ \frac{1}{j\omega C_2} & \text{(contact open)} \end{cases} \quad (46)$$

where  $\underline{Z}_5$  is known by eq.43.

The impedance  $\underline{Z}_4$  is transformed into the admittance  $\underline{Y}_4$ :

$$\underline{Y}_4 = \frac{1}{\underline{Z}_4} \quad (47)$$

The admittance  $\underline{Y}_4$  has to be added to the admittance of the lossy inductivity L:

$$\underline{Y}_3 = \underline{Y}_4 + G_L + \frac{1}{j\omega L} \quad (48)$$

and is then transformed into the corresponding impedance  $\underline{Z}_3$ . The capacitor  $C_1$  has to compensate for the imaginary part  $X_3$  of the impedance  $\underline{Z}_3$ :

$$C_1 \stackrel{!}{=} \frac{1}{\omega \cdot X_3} \quad (49)$$

As the variation range of the capacitor  $C_1$  is between  $C_{\min} = 12\text{pF}$  and  $C_{\max} = 500\text{pF}$  the compensation may fail. In this case the most favorable value of  $C_1$  is chosen ( $C_{\min}$  or  $C_{\max}$ ). The impedance  $\underline{Z}_2$  becomes:

$$\underline{Z}_2 = \underline{Z}_3 + R_c + \frac{1}{j\omega C_1} \quad (50)$$

The standing-wave ratio at pins 1-1' can be found by

transforming  $Z_2$  to  $Z_1$  with the transformer T and referring  $Z_1$  to  $R_Q$ :

$$SWR = \frac{1 + |\underline{x}|}{1 - |\underline{x}|} \quad (51)$$

where:

$$\underline{x} = \frac{4 \cdot Z_2 - R_Q}{4 \cdot Z_2 + R_Q} \quad (52)$$

If the SWR is less than  $SWR = 400$ , the computer stores this value. Otherwise, the probability of getting a SWR of less or equal  $SWR = 2$  by a fine-tuning of L is extremely low. Among the stored values, the computer takes that one with the smallest SWR and optimizes it by a fine-tuning of L and  $C_1$ . The optimization stops at  $SWR < 1.002$ , or after 20 tuning routines.

### 5. Calculation of powers, voltages and currents

If the optimized SWR is not greater than  $SWR = 2$  the currents, voltages and powers are computed for an available generator power of  $P_a = 100$  Watts. The input power  $P_1$  delivered to the coupler is

$$P_1 = P_a \cdot (1 - |\underline{x}|^2) \quad (53)$$

The amplitudes of the voltage  $U_{i-i'}$ , and the current  $I_i$ , referred to any pins  $i-i'$  are dependent on the power  $P_{i-i'}$ , delivered to these pins:

$$U_{i-i'} = \sqrt{\frac{2 \cdot P_{i-i'}}{G_{i-i'}}} \quad (54)$$

$$I_{i-i'} = \sqrt{\frac{2 \cdot P_{i-i'}}{R_{i-i'}}} \quad (55)$$

where:  $G_{i-i'} = \text{Re} \{ \underline{Y}_{i-i'} \}$ , and:  $R_{i-i'} = \text{Re} \{ \underline{Z}_{i-i'} \}$

The power  $P_{2-2'}$ , at pins 2-2' is the same as  $P_1$  since the transformer is assumed to be lossless. The current  $I_2$  causes losses at the capacitor  $C_1$ , represented by the contact resistance  $R_c$ . On this account the power  $P_{2-2'}$ , flowing through pins 3-3' is:

$$P_{3-3'} = P_{2-2'} - \frac{1}{2} \cdot I_2^2 \cdot R_c \quad (56)$$

The current  $I_2$  is found using eq.55.

The voltage  $U_{3-3'}$ , causes losses within the coil L represented by its parallel conductance  $G_L$ . The remaining power  $P_{4-4'}$ , is:

$$P_{4-4'} = P_{3-3'} - \frac{1}{2} \cdot U_{3-3'}^2 \cdot G_L \quad (57)$$

The power  $P_{5-5'}$  is, because of the contact losses at  $C_2$ :

$$P_{5-5'} = P_{4-4'} - \frac{1}{2} \cdot I_4^2 \cdot R_C \quad (58)$$

The power  $P_{5-5'}$  feeds either directly (antenna type 1) or via the coaxial line (antenna type 2) to the antenna. Since the cable losses have been substituted by the serial resistance  $R_{Lc}$  at the antenna feeding point, the cable can be handled like a lossless line with the power  $P_{6-6'}$  at the output:

$$P_{6-6'} = P_{5-5'}$$

The output current and voltage can be calculated using again eq.54 and eq.55. With antenna type 2, the losses of the line become:

$$P_{Lc} = \frac{1}{2} \cdot I_6^2 \cdot R_{Lc} \quad (59)$$

as:  $I_6 = I(0)$

The final radiated power is:

$$P_r = \frac{1}{2} \cdot I_6^2 \cdot R_r \quad (59a)$$

The power lost by the surface-resistance of the antenna elements is:

$$P_{La} = \frac{1}{2} \cdot I_6^2 \cdot R_a$$

and the power lost by the contact resistances is:

$$P_c = \frac{1}{2} \cdot I_6^2 \cdot R_c \quad (59c)$$

Since the available power is chosen to be 100 Watts, the calculated powers are identical to the percentage of total power available from the transmitter.

## 6. Optimization of the antenna

The parameters of the antenna which can be varied are:

- antenna type

- length  $a$
- diameter  $d$
- length  $a_1$  of the parallel open ended line (type 1 only)
- characteristic impedance  $Z_0$  of the coaxial feeder line (type 2 only)

For each frequency (3, 4 and 5MHz) which has been investigated, a different optimized antenna could be found. The following figures show the parameter variation for the two antenna types.

Fig.39 represents the dependence of the total efficiency of antenna type 1, including the HARRIS-coupler, on the length of the antenna elements and the transmitter frequency  $f$ . The diagram shows:

1. The efficiency increases with the frequency, mainly because of the increasing Q-factor of the coil.
2. The longer the antenna, the better the efficiency.

The diagram documents that maximum efficiency will occur at a frequency of 5MHz if the length of the antenna elements is  $l = 15m$ . On the other hand, the coupler will not be able to match the antenna at a frequency close to resonance. Therefore the maximum length of the antenna is only 16m for  $f = 3MHz$ , 10m for  $f = 4MHz$  and 6m for  $f = 5MHz$ . If the whole frequency range from 3 MHz up to 5 MHz shall be used, the maximum length of the antenna has to be  $a = 6m$  to keep it tunable. With this length, a diameter of  $d = 7.5cm$ , and no parallel line, the efficiency will be about 0.4% at 3MHz, 1% at 4MHz and 2.7% at 5MHz.

Fig.40 shows the total efficiency of the antenna configuration, depending on the antenna diameter  $d$ . The efficiency decreases with increasing diameter. Therefore the lower boundary seems to be the mechanical stability of the antenna.

The length  $a_1$  of the parallel open-ended line, up to  $a_1 = 4m$  has nearly no influence on the antenna efficiency, as shown in Fig.41. So these elements should be omitted.

If the three parallel antenna elements are spaced closer together, the antenna's characteristic impedance is increased and the efficiency can be raised further.

The optimum sized antenna of type 1 has to have:

- a length as long as possible for matching
- a diameter as small as possible for matching and as justifiable for stability

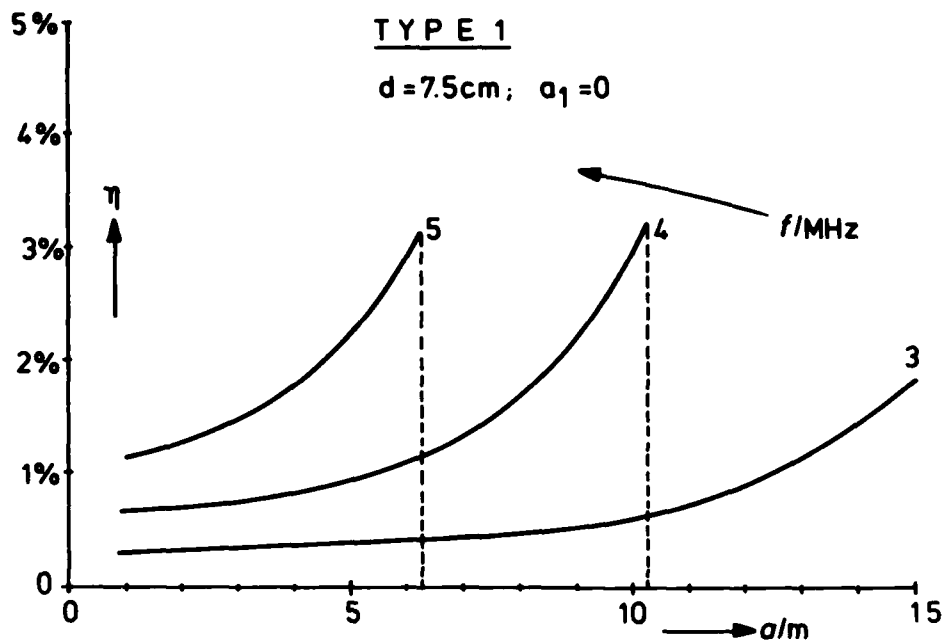

Fig. 39: Total efficiency  $\eta$  of antenna type 1 depending on the length  $a$  of the antenna elements and on the frequency  $f$

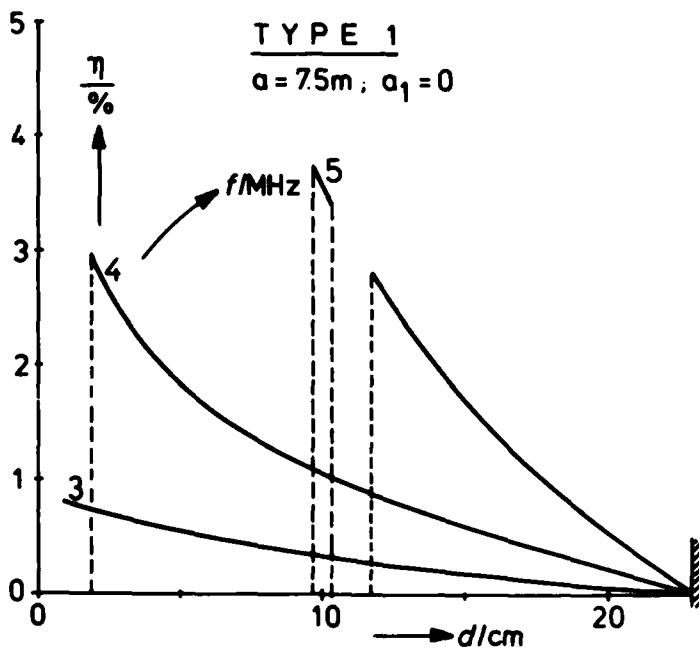

Fig. 40: Total efficiency  $\eta$  of antenna type 1, depending on the diameter  $d$  of the antenna elements and on the frequency  $f$

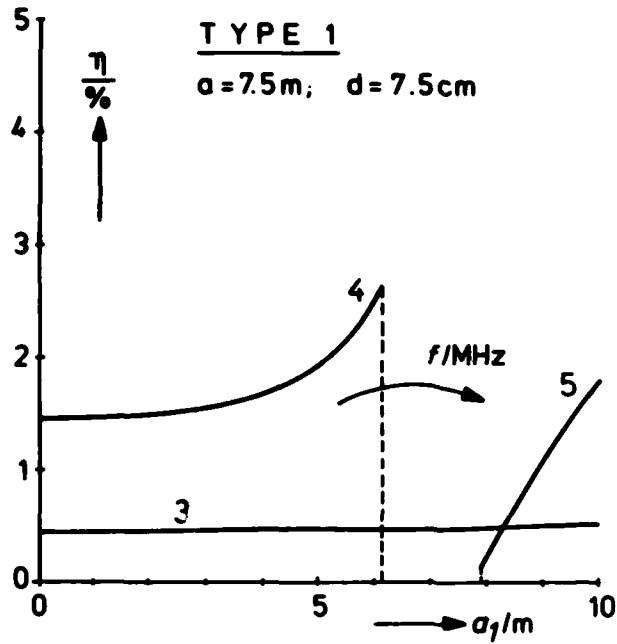

Fig. 41: Total efficiency of antenna type 1, versus length  $a_1$  of the open-ended parallel line. Parameter: frequency  $f$

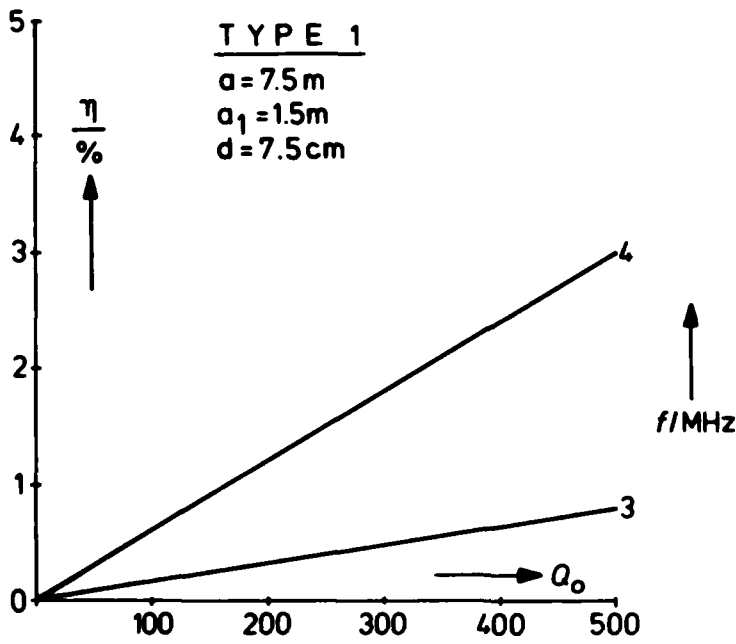

Fig. 42: Total efficiency  $\eta$  of antenna type 1 versus maximum Q-factor  $Q_0$  of the variable inductor  $L$ . Parameter: frequency  $f$

- the antenna elements mounted very close together.

For example, an aluminum construction with a length of  $a = 10\text{m}$ , an open-ended parallel line of the length  $a_1 = 0$ , a diameter of  $d = 4\text{cm}$  and a total width of  $b = 40\text{cm}$  might fulfill these demands and would result in a total efficiency of 1% at  $f = 3\text{MHz}$  or a gain of more than 4dB compared to the currently existing antenna. Unfortunately, this antenna cannot be matched at 4MHz and 5MHz with the applied coupler. That means that the optimized antenna for the critical, i.e. the lowest frequency, is not tunable at the remaining frequencies. This tendency can be seen with both antenna types. Therefore a compromise must be made between efficiency at the lowest frequency and tunability at the remaining frequencies. Antenna type 1 in the existing realization has an efficiency of about 0.4% at 3MHz and is an acceptable solution. But even with these dimensions the coupler will not be able to tune the antenna at the highest frequency.

Antenna type 2 allows a much higher efficiency than type 1. At 3MHz the efficiency can be calculated to be greater than 12 percent for an antenna with the element length  $a = 10\text{m}$ , the diameter of the elements of  $d = 13\text{cm}$  and a 50-Ohm feeder line. If the diameter is increased a small amount, the antenna can no longer be tuned. Fig.46 documents the tuning problem. By increasing the length of the antenna elements, the current through the coupler's inductivity  $L$  is made smaller and smaller, while simultaneously its Q-factor becomes better. This improvement is only usable until the maximum inductance of the variable coil  $L$  is attained. Better efficiency could be possible by choosing a longer antenna, but the built-in inductivity cannot be tuned to the optimum antenna type. Unfortunately, the maximum ranges and the non-tunable ranges at the different frequencies are overlapping. With the remaining parameters fixed, as stated in Fig.43, the antenna is only tunable at all three frequencies if the length  $a$  is greater than 10m. The achievable efficiency with these antenna dimensions will be between 1.6% to 5.5% - and so still much better than the currently existing antenna.

As described before, the efficiency of antenna type 1 is increased by decreasing the diameter of the antenna elements. As documented in Fig.44, the influence of the diameter on the efficiency of antenna type 2 is vice-versa than with type 1. At 3 MHz, a maximum occurs with an efficiency of about 8%, when  $d = 13\text{cm}$ . With a diameter between  $13\text{cm} < d < 19\text{cm}$  or greater than  $d = 21\text{cm}$ , the antenna is not tunable. At  $f = 4\text{MHz}$  the diameter has to be less than  $d = 20\text{cm}$  and at  $f = 5\text{MHz}$  less than  $d = 22\text{cm}$ . The 5MHz plot shows two steps which are caused by the relay in parallel with the serial capacitor  $C_2$  within the coupler. With the relay contact open, the efficiency is usually less than when closed. When the antenna diameter is between  $9\text{cm} < d < 13\text{cm}$ , the

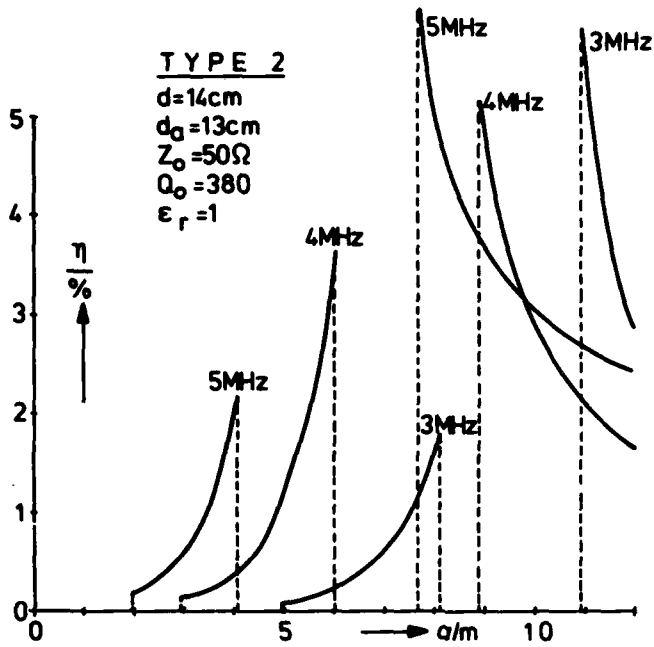

Fig. 43: Total efficiency of antenna type 2, versus length  $a$  of the antenna elements. Parameter: frequency  $f$

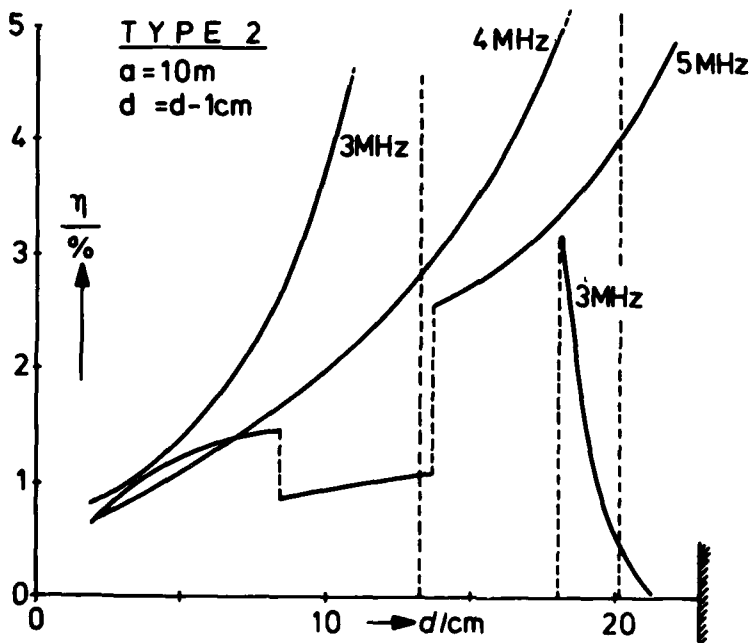

Fig. 44: Total efficiency of antenna type 2 versus diameter  $d$  of the antenna elements. Parameter: frequency  $f$

antenna can only be tuned if  $C_2$  is activated.

The characteristic impedance  $Z_0$  of the feeder line strongly influences the antenna efficiency as shown in Fig.45. At 3MHz the characteristic impedance has to be within 20 Ohms to 40 Ohms to get an efficiency between 0.6% and 5.5% with the stated antenna dimensions. With any other characteristic impedance the antenna is not tunable. At 4MHz an efficiency of up to 9% can be achieved and the characteristic impedance has to be between 20 Ohms and 80 Ohms. At 5MHz the antenna is tunable for  $20 \text{ Ohms} < Z_0 < 120 \text{ Ohms}$ . The maximum efficiency is 9.5%.

Also, for type 2 the optimum antenna has to be a compromise between high efficiency and tunability in the full frequency range.

An antenna with the dimensions:

$$\begin{aligned} a &= 10\text{m} \\ d &= 12.8\text{cm} \\ Z_0 &= 50 \text{ Ohm} \\ \epsilon_r &= 1.0 \end{aligned}$$

will give an excellent result of more than 11% total efficiency at  $f = 3\text{MHz}$ . It will be easily tunable at this frequency as shown in Fig.46. With an inductivity of  $L = 46\mu\text{H}$  the current in the coil will be very low and the Q-factor nearly as high as possible because all turns are used. Capacitor  $C_1$  will be tuned to  $C_1 = 52\text{pF}$  and capacitor  $C_2$  will be by-passed. The coil will convert 33% of the generator power to heat and only 0.16% of the variable capacitor. The losses of the coaxial feeder line are about 16% of the generator power and the contact losses and the losses of the antenna itself will be 40% of the available generator power. The losses of the antenna are uncharacteristically high at this configuration. The reason is that the radiating gap between the antenna elements and the roof is very narrow. Therefore the radiation resistance is very low ( $10\text{m}\Omega$ ). The loss resistances are more than three times greater. On the other hand, this narrow gap causes a quite low imaginary part of the antenna impedance which is transformed by the coaxial line to a capacitive load of about  $9\text{pF}$ , roughly equivalent to a 1m whip-antenna. but with significantly higher real part. As mentioned before, the total efficiency of this antenna is more than 11% at 3MHz, 14dB better than the existing antenna. For  $f = 4\text{MHz}$  and  $f = 5\text{MHz}$  the antenna efficiency is considerably smaller, as the current through the variable coil is higher and the number of turns used is very small. So the antenna will radiate about 2.5% of the available generator power at 4MHz and only 1% at 5MHz. The power lost in the variable coil will be 92% and 96%, respectively.

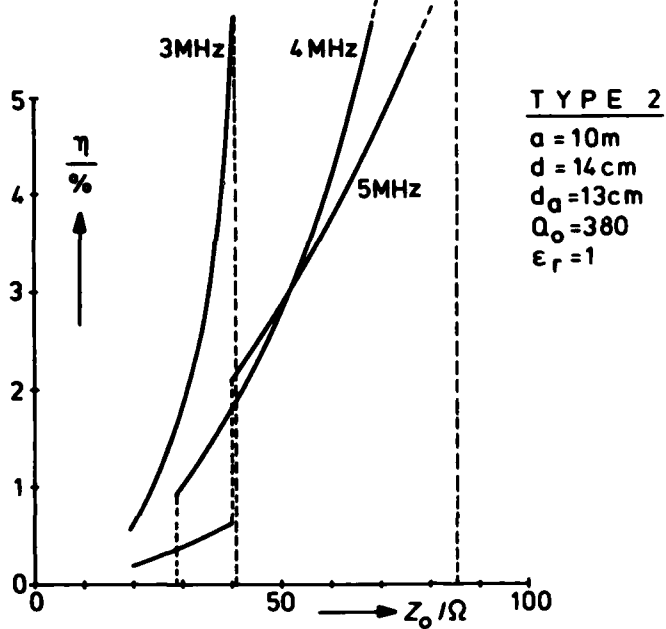

Fig. 45: Total efficiency of antenna type 2 versus characteristic impedance  $Z_0$  of the feeder line. Parameter: frequency  $f$

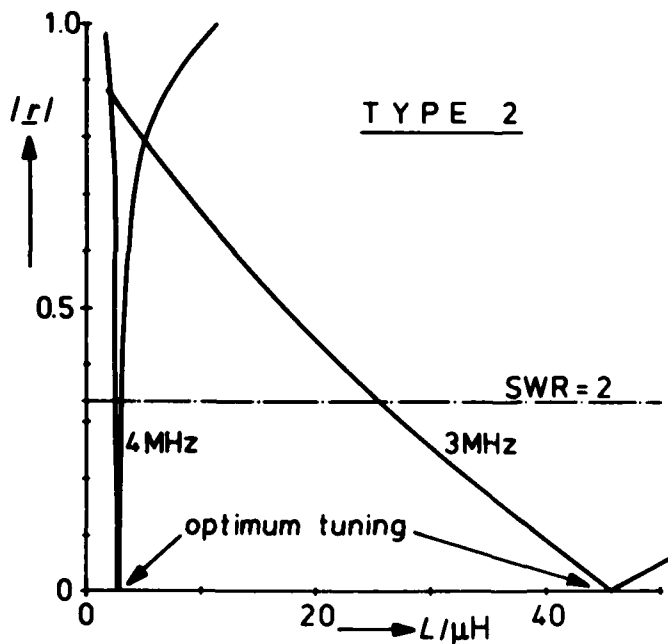

Fig. 46: Comparison of the dependence of the coupler input reflection coefficient  $r$  on the inductance  $L$  of the variable coil at 3 MHz and 4 MHz

Fig.47 shows the drawing of antenna type 2 with the proposed features.

#### 7. Bandwidth of the tuned antenna

The bandwidth of electrical small antennas is usually small and the antenna's reactive power is much greater than the radiated power. For the antenna-coupler configuration, the bandwidth calculation needs more effort than for the antenna itself since the matching network is tunable and lossy.

The bandwidth has also been computed utilizing the program described before. When the coupler elements have been tuned for a fixed frequency, the input frequency is varied slightly, with fixed coupler elements. For each frequency the output power and the coupler input-reflection coefficient is calculated and plotted, as shown in Fig.48 for antenna type 1. The frequency variation is  $\pm 10$ kHz and the centre frequencies are 3MHz, 4MHz and 5MHz.

The output power is nearly independent of the frequency variation with this antenna type when the bandwidth necessary for single-sideband (SSB) communication (2.7kHz) is used. The output power changes less than 0.8% in this range and the reflection coefficient is less than 6%, corresponding to a standing-wave ratio of  $SWR \leq 1.128$ . For telegraphy (CW) and for radio teletype (RTTY) communications the results will be even better because of the smaller bandwidth.

Fig.49 shows the corresponding plots for antenna type 2 with the optimized outlines (see chapt.6). The bandwidth achievable with this type of antenna is much smaller, but it will be sufficient even for SSB communication at the lowest and therefore most critical frequency of 3MHz ( $B \approx 2.4$ kHz). The bandwidth tolerable from the maximum transmitter load standing-wave ratio of  $SWR \leq 2$  is distinctly lower ( $\approx 1.36$ kHz at 3MHz). This bandwidth would be detracting for a long-time sinusoidal SSB modulation signal. As speech consists of a mixture of different frequencies at each time-interval, the maximum RMS standing-wave ratio will usually not be exceeded with a speech signal of 2.7kHz bandwidth.

#### 8. Measurement results

We investigated the currently existing antenna type 1 as well as a test antenna of type 2 with the non-optimum outlines:

a = 12m  
d = 2cm

inner diameter: 0.118m  
inner line: 0.053m

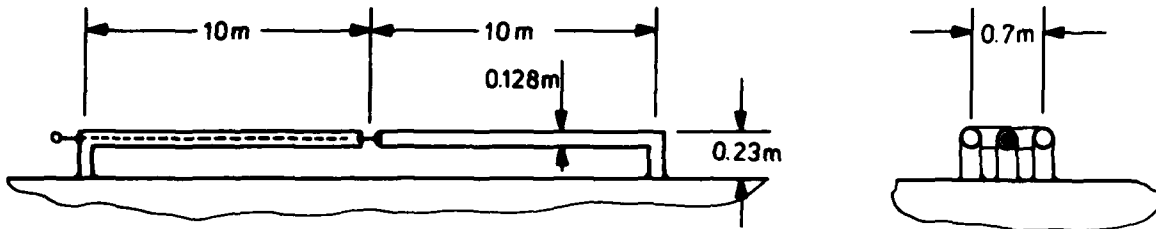

a) outline dimensions

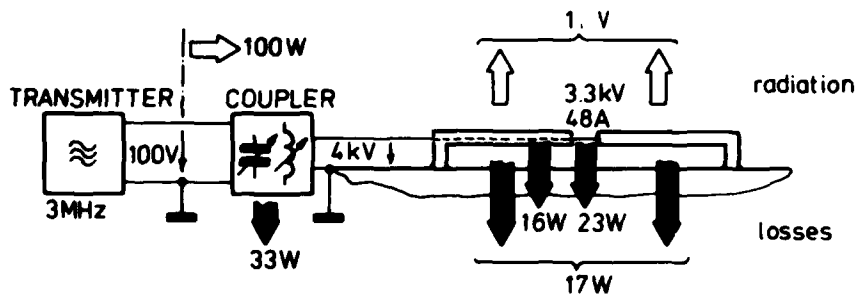

b) flow graph for 100 W available transmitter power

Fig. 47: Antenna type 2, optimized for  $f = 3$  MHz

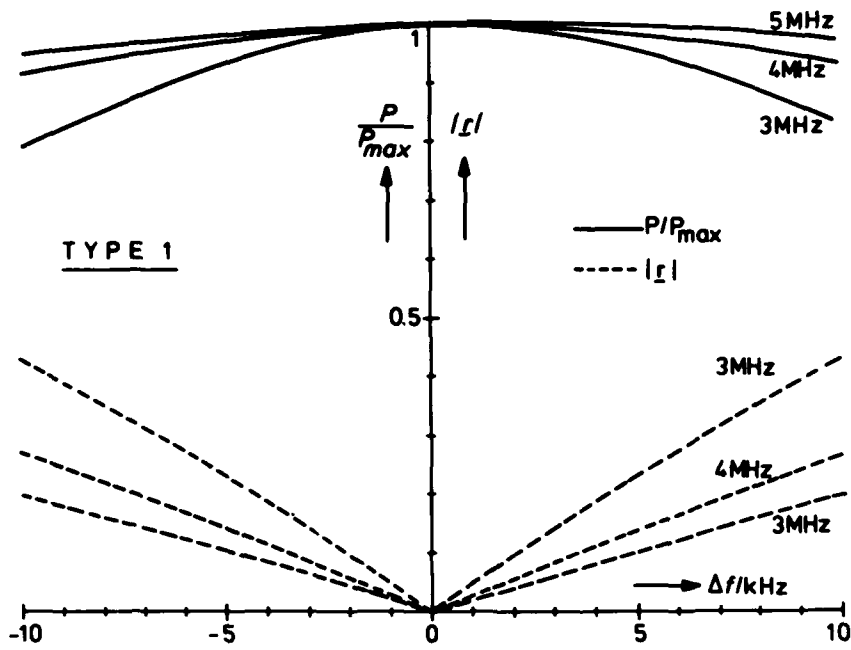

Fig. 48: Antenna type 1 - radiated power P and input reflection coefficient r versus frequency offset. Centre frequencies are 3 MHz, 4 MHz and 5 MHz

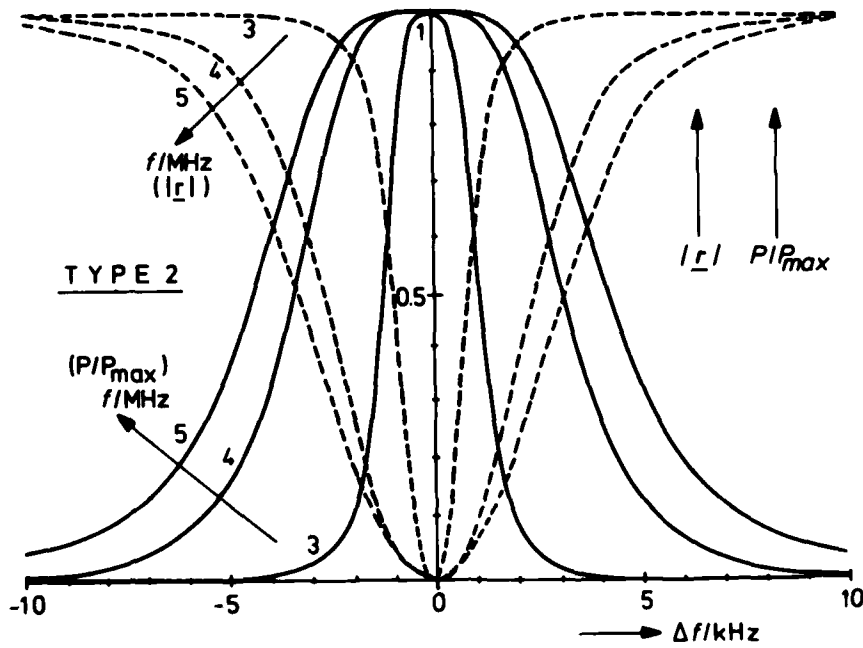

Fig. 49: Optimized antenna type 2 - radiated power and input reflection coefficient r versus frequency offset

$$\begin{aligned} Z &= 50 \text{ Ohm} \\ \epsilon_r &= 1.2 \\ D &= 1.7 \text{ cm} \end{aligned}$$

The antennas were measured on top of the train.

Fig.50 shows the calculated and the measured imaginary part of the input impedance of antenna type 1, depending on the frequency. The real part of the impedance is much smaller than its imaginary part and cannot be measured directly with a vector impedance meter. At 3MHz the measured inductive impedance fits with the calculated value. At higher frequencies, the measured values are distinctly higher than the calculated values since the quarter-wavelength resonance appears at a lower frequency than expected from the antenna length (8.3MHz). Therefore, at the real antenna there has to be some additional capacitors. This result is quite reasonable since the capacitive insulator constructions that hold the antenna elements and the connection lines between the elements have not been considered.

Fig.51 shows the imaginary part of the calculated and measured impedance of antenna type 2 at the coaxial feeder point. Again the real part is too small to be measured. The imaginary part is capacitive, since the inductive imaginary part of the antenna impedance at the symmetrical feeder point is transformed by the coaxial line, the length of which is close to the quarter wavelength.

The transformation is very sensitive to any change of the dimensions or the frequency since the antenna and line together act as a high-Q-resonance circuit close to the resonance. So, for example, the input reflection coefficient at the coaxial input shows a frequency dependence on the phase angle which is nearly four times greater than the frequency dependence on the phase angle of the antenna's reflection coefficient itself. Also, the small bandwidth of antenna type 2 compared to type 1 is caused by the sensivity of this transformation.

The measured values of the coaxial input impedances imaginary part show an offset of about 25 Ohms compared to the calculated values. This effect is caused by the extremely long vertical short circuit rods (22cm) and by the actual shape of the roof, which for the calculations has been assumed to be flat. This assumption is not accurate if the distance between the fictitious line current and the roof becomes as high as with this test antenna.

Besides this offset, the frequency dependence of the measured and the calculated impedance correspond quite well.

Fig.52 shows the calculated and measured frequency dependence of

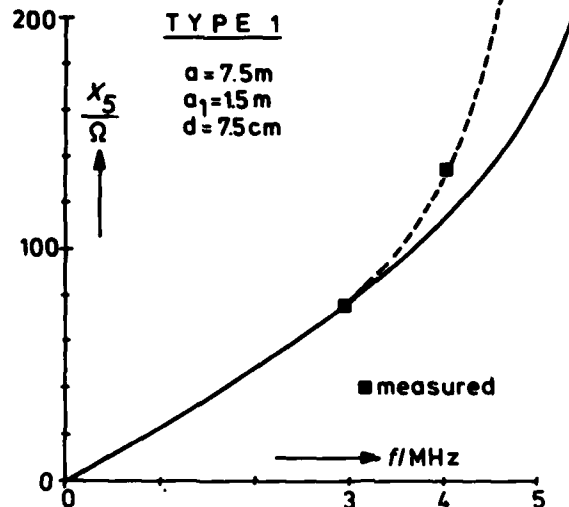

Fig. 50: Antenna type 1 - comparison of calculated and measured imaginary part  $X_5$  of the antenna impedance  $Z_5$

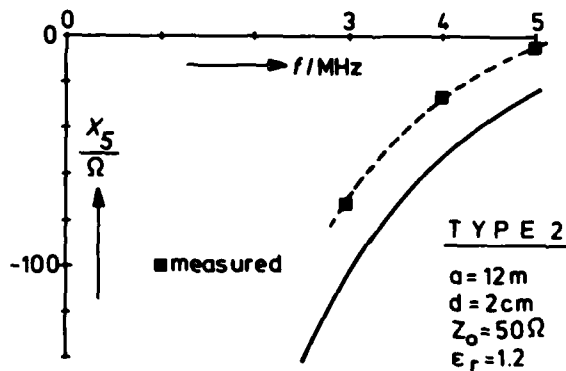

Fig. 51: Antenna type 2 - comparison of calculated and measured imaginary part  $X_5$  of the antenna impedance  $Z_5$

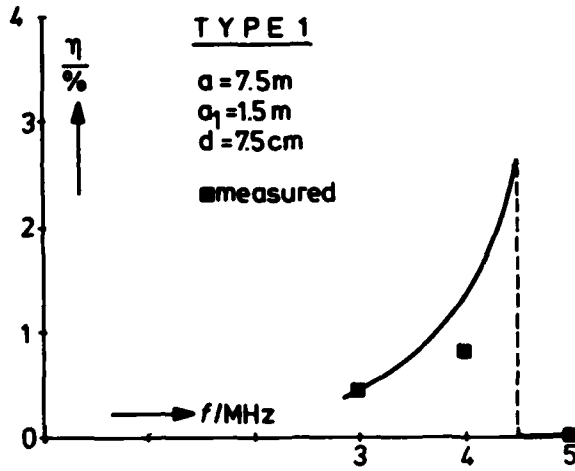

Fig. 52: Antenna type 1 - calculated and measured total efficiency  $\eta$  versus frequency

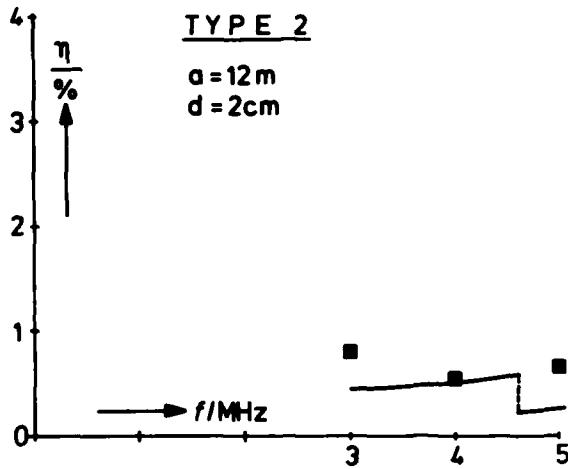

Fig. 53: Antenna type 2 - calculated and measured total efficiency versus frequency

the total efficiency of antenna type 1 and coupler. At 3MHz the measured and the calculated results are identical, like the measured and calculated results of the antenna impedance at this frequency. At 4MHz the measured result is about 3dB worse than the calculated value. At frequencies greater than about 4.5MHz the antenna is theoretically not tunable. This is confirmed by the measured results.

The correspondence of calculated and measured data is quite good, although several estimations and some approximations have been used. Besides this, the train could not be measured standing at a free area. Furthermore, the uncertainty of the field strength measurement setup is not better than about 2dB.

The correspondence of measured and calculated data of the total efficiency of antenna type 2, shown in Fig.53, is also quite good. The difference at 3MHz is about 3dB, at 4MHz less than 0.3dB and at 5MHz about 4dB.

Fig. 55 shows the comparison of the measured and the calculated radiation patterns in the plane  $\theta = 90^\circ$ . The investigated antenna is antenna type 2 at a frequency of  $f = 3\text{MHz}$ . The receiving antenna used vertical polarization. The distance between train and receiver was about 1km. The test car was equipped with an active loop antenna (R&S HFH2-Z2) and a receiver (R&S ESH2) for the field strength measurements (see Fig.59). The test points (C1 - C4) which were chosen are shown at the map of Fig.54. Within 2dB the calculated curve fits with the measurement results.

To document how the electrical field strength depends on the distance, compared to the CCIR-Recommendation 368-4, Vol. V, Geneve 1982 the field strength was measured at three more testpoints (MP2, MP3 and MP4) at distances of 2km, 3.3km and 4.6km. The azimuth angles were between  $76^\circ$  and  $83^\circ$ . Referred to an effective radiated power of 1kW, the measurement results for 3MHz (Fig.56) and 5MHz (Fig.57) are within the CCIR-curves for ground-conductivities of  $\sigma = 3 \cdot 10^{-2}\text{S/m}$  and  $\sigma = 10^{-5}\text{S/m}$  and very close to the documented  $\sigma = 10^{-3}\text{S/m}$ -curve (Europe near the alpes:  $\sigma = 3 \cdot 10^{-3}\text{S/m}$ ).

With the results of the measurements and the calculations and with the help of the CCIR-Recommendations and Reports it is therefore possible to estimate the communication distance for ground-wave propagation, achievable with the system.

Fig. 58 shows the flow graph from the transmitter T to the receiver R. The transmitter delivers its available power  $P_a$  to the matching network  $NW_T$  with the efficiency  $\eta_T$ . The network output power  $\eta_T \cdot P_a$  is radiated from the antenna to free space with the partial vertical directivity  $d_T$  in the direction of the

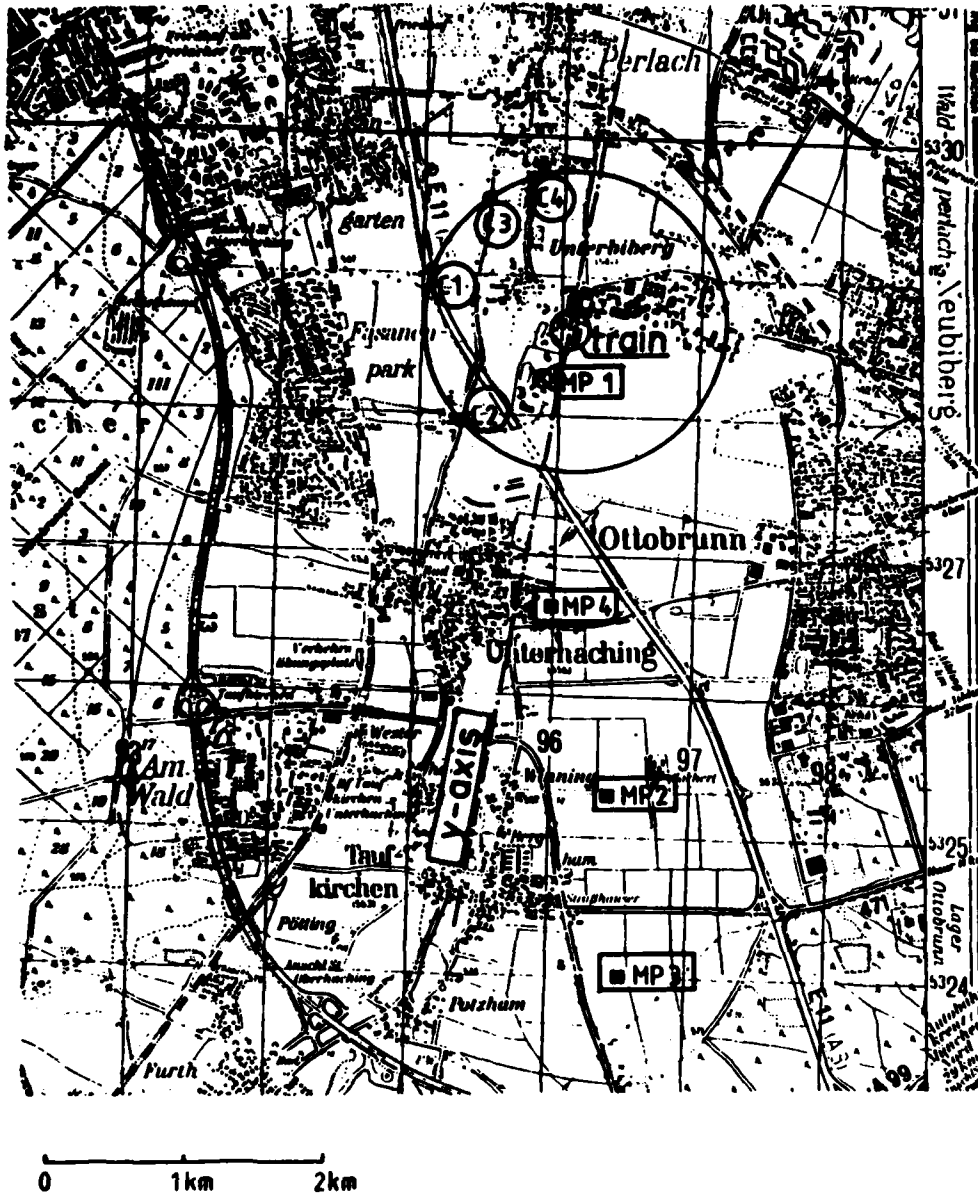

Fig. 54: Location of test points for the measurement of

- total efficiency  $\eta$  (MP1)
- propagation (MP2-MP4)
- radiation pattern (C1 - C4)

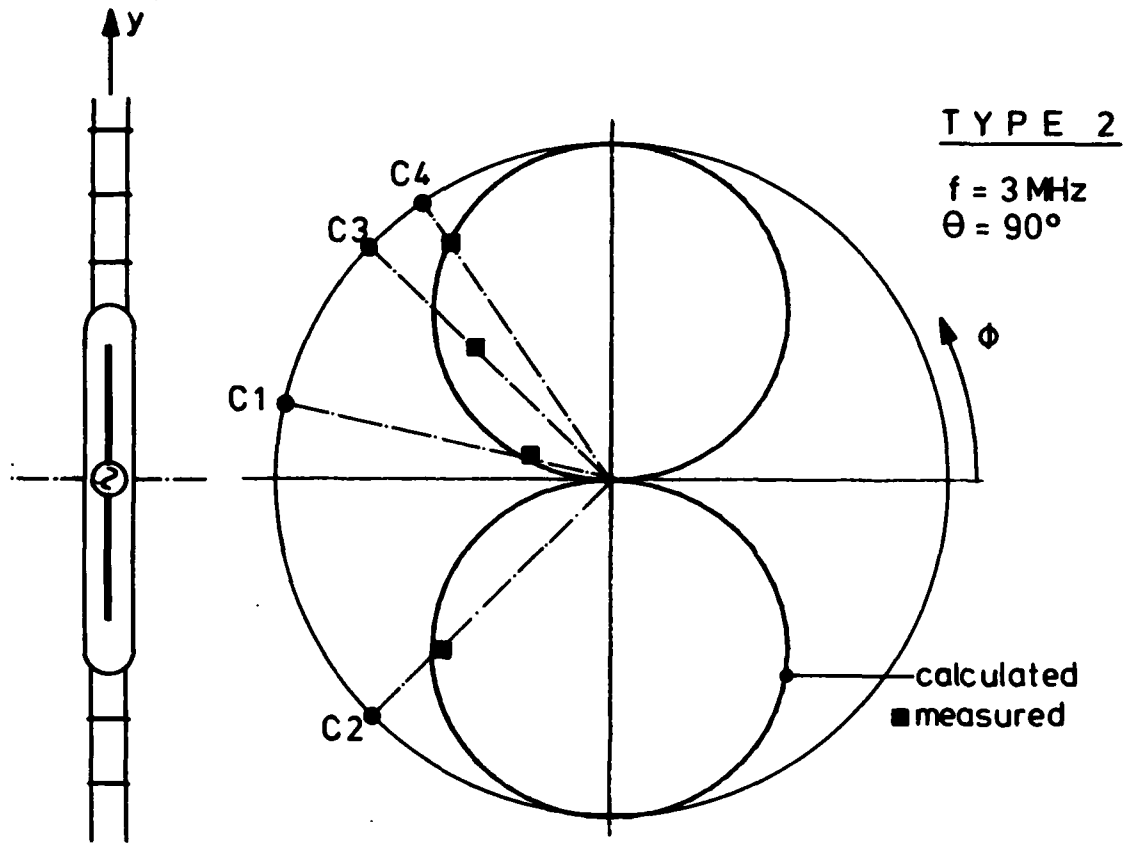

Fig. 55: Antenna type 2 - comparison of calculated and measured radiation pattern in the  $\theta = 90^\circ$ -plane

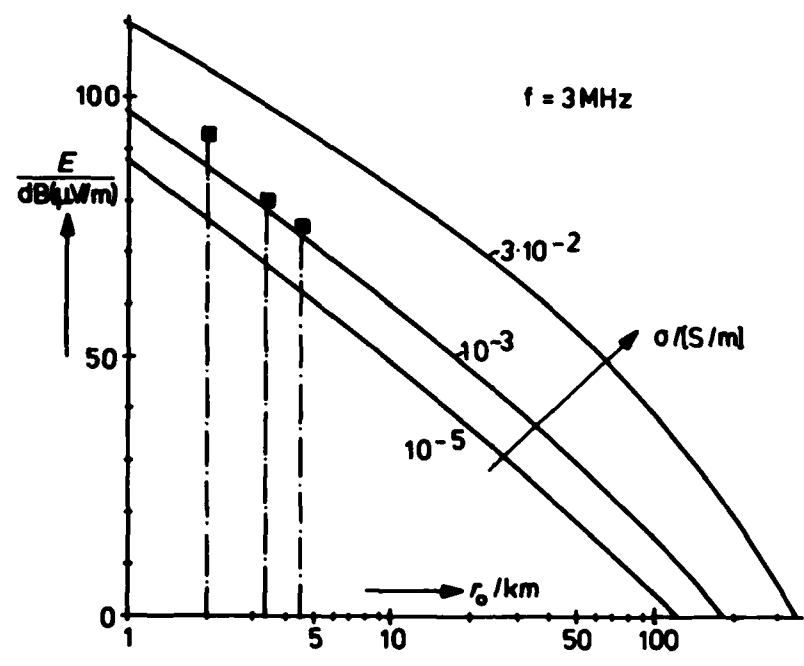

Fig. 56: Antenna type 1 - comparison of measured fieldstrength and ground-wave propagation curves with different ground conductivity  $\sigma$  ( $P_r = 1\text{ kW}$ )

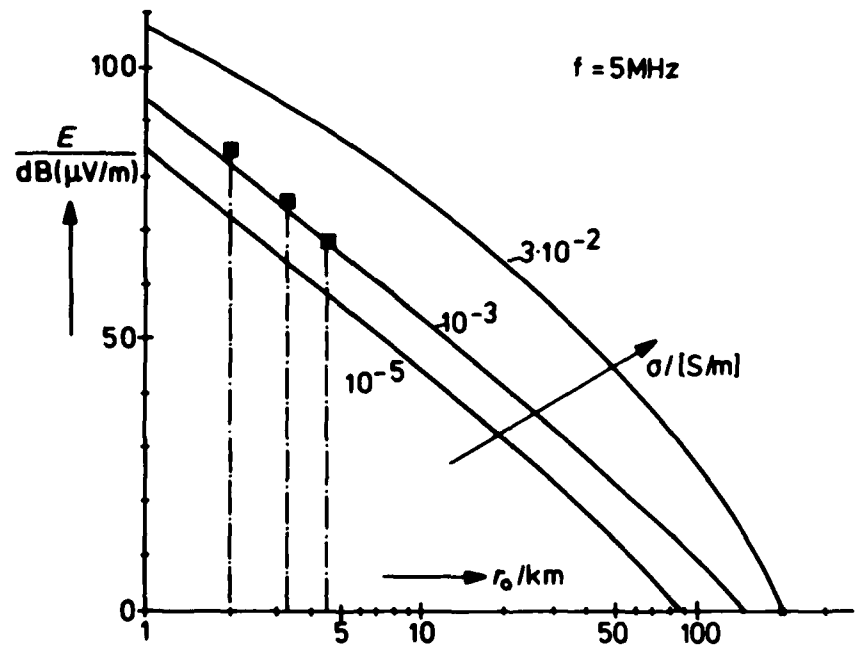

Fig. 57: Antenna type 1 - comparison of measured fieldstrength and ground-wave propagation curves with different ground conductivity  $\sigma$  ( $P_r = 1\text{ kW}$ )

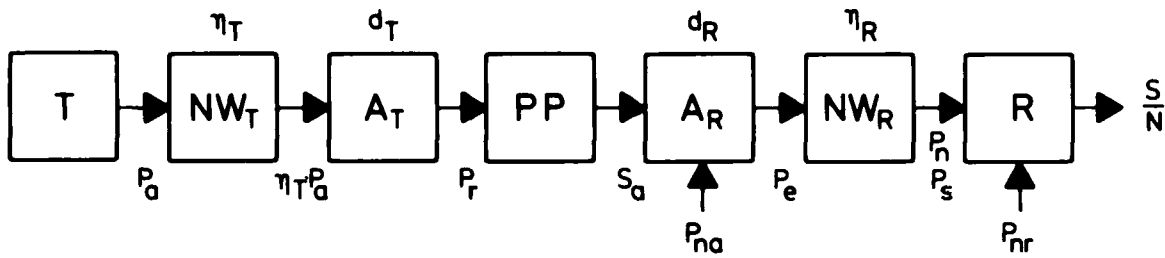

Fig. 58: Flow chart for signal and noise in a radio telecommunication link

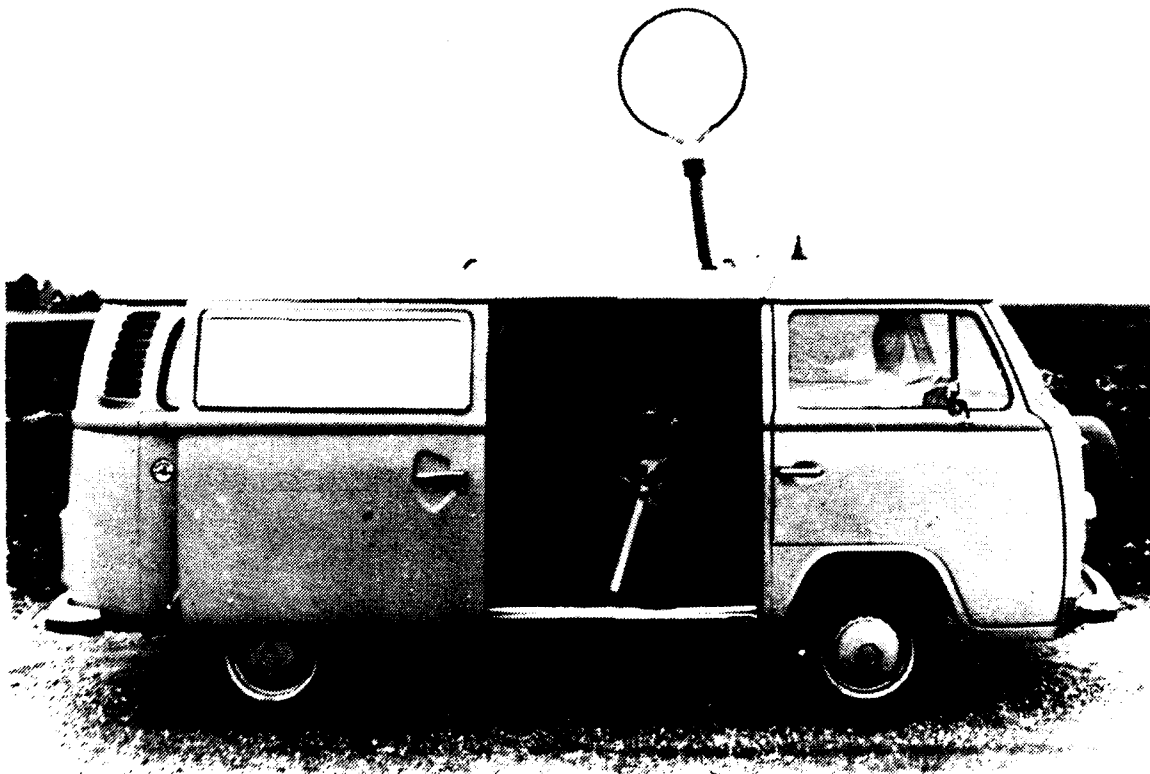

Fig. 59: Test car, equipped with an active loop-antenna (HFH2-Z2, R&S) and a selective level meter (ESH2, R&S)

receiver. The propagation path PP is described by the CCIR-recommendation 368-4. The electrical field strength E at the receiving antenna can be found by help of this documentation depending on the frequency, the radiated power, the distance, and the ground conductivity.

The receiving antenna A delivers the power

$$P_e = \frac{\lambda_c^2}{16 \cdot \pi} \cdot d_R \cdot \frac{E^2}{Z_i} \quad (60)$$

to the matching network. The partial directivity of the receiving antenna is  $d_R$ . The matching network has the efficiency  $\eta_R$ .

In addition to the signal field strength E there will be a noise field strength  $e_n$  at the receiving antenna which depends not only on the frequency, but also on the surroundings ("man-made" noise sources) and the time of day. The noise power  $P_{na}$  received by the antenna inside the receiver bandwidth B can be added to the available thermal noise power  $P_{no}$  of the antenna source resistance. Because of this, the noise figure  $F_a$  of the antenna will be:

$$F_a = \frac{P_{na}}{P_{no}} \quad (61)$$

$$P_{no} = k \cdot T_o \cdot B \quad (62)$$

The typical noise figure of antennas depending on the frequency and the surrounding is documented in Report 670 of the CCIR-Recommendations and Reports, Vol.I. In the frequency range from 3MHz to 5MHz the noise figure is stated to be between  $F_a = 40\text{dB}$  ("silent surrounding") and  $F_a = 70\text{dB}$ .

Signal and noise are attenuated by the lossy antenna matching network  $NW_R$  of the receiving system. The signal  $P_s$ , delivered to the receiver is:

$$P_s = \eta_R \cdot P_e \quad (63)$$

The noise power  $P_n$ , delivered to the receiver is:

$$P_n = (P_{na} + P_{no}) \cdot \eta_R \quad (64)$$

As the receiver itself produces noise, the signal-to-noise ratio is decreased further:

$$\frac{S}{N} = \frac{P_s}{P_n + P_{nr}}$$

The additional receiver noise  $P_{nr}$  is usually described by the receiver noise figure  $F_r$ :

$$F_r = \frac{P_{nr}}{P_{nO}} \quad (65)$$

where  $P_{nO}$  is the noise power delivered by the source resistance at the temperature  $T_O$  (normally:  $T_O = 288K$ ). The receiver noise figure in the frequency range from 3MHz to 5MHz is typically about  $F_{r, dB} \approx 8dB$ . As the antenna is matched to the receiver input impedance, there is no difference between available and delivered power.

The signal-to-noise ratio at the receiver output port thus becomes:

$$\frac{S}{N} = \frac{\eta_R \cdot \lambda_o^2 \cdot d_R \cdot E^2}{16 \cdot \pi \cdot Z_i \cdot k \cdot T_O \cdot B \cdot [\eta_R (F_a + 1) + F_r]} \quad (67)$$

For a certain desired minimum signal-to-noise ratio  $(S/N)_{min}$  the electrical field strength  $E$  at the receiving antenna must not be lower than:

$$\begin{aligned} \frac{E}{[dB(\mu V/m)]} &= 20 \cdot \log \frac{f}{[MHz]} + \left(\frac{S}{N}\right)_{min} - 64 + \\ &+ 10 \cdot \log \frac{B}{[kHz]} + 10 \cdot \log \left(1 + F_a + \frac{F_r}{\eta_R}\right) \end{aligned} \quad (68)$$

By help of the CCIR-field strength curves the maximum usable distance can be estimated, using this equation.

A typical example is:

- SSB-communication ( $B = 2.7kHz$ )
- good readability ( $(S/N)_{min} = 20dB$ )
- antenna noise figure  $F_a = 40dB$
- receiver noise figure  $F_r = 8dB$
- available transmitter power  $P_a = 300W$
- medium dry ground ( $\sigma = 10^{-3} S/m$ )

If transmitter and receiver use the railroad-train antenna type 1 the maximum usable distance for ground-wave communication will be about 30km at 3MHz.

If a better antenna, like a 15ft-whip antenna or the optimized antenna type 2 is used for transmitting only, the maximum distance will increase to 70km at 3MHz.

Even with a poor total antenna efficiency, the antenna noise is much stronger than the receiver noise and the influence of different antenna types on the receiver sensitivity is extremely low (less than 1dB). Therefore the maximum usable distance can

only be increased by increasing the radiated signal power or by decreasing the signal bandwidth or the minimum signal-to-noise ratio.

If, for example, a minimum S/N-ratio of  $(S/N)_{\min} = 10\text{dB}$  will be accepted and RTTY with a frequency shift of 700Hz is used, the maximum usable distance at 3MHz will be 100km with antenna type 1 and close to 200km with the optimized antenna type 2.

The good conductivity of the rails and the influence of the overhead-contact lines will increase the maximum distance further.

Using the sky-wave for communication will change the attenuation of the propagation path remarkably. In this case the maximum usable distance depends additionally on the time of day, the season, and the sun-spot activities. The maximum distance can be much greater than that achievable with the ground-wave. The probability that ionospheric propagation can be used for communication can be taken from actual prediction charts.

#### Acknowledgement

The authors wish to thank LtCol. Harvey, R. Sauer and Cpt. Thomas for various aids during the preparation of this report.

Many thanks also to Col. Sheffield who reviewed the manuscript and suggested several improvements.

A P P E N D I X A : Bibliography

- /1/ Niklasch, Norbert: Magnetic Transmitting and Receiving Antenna for a Railway Car, Diploma Thesis, University of the Bundeswehr, Munich, Dec. 1983
- /2/ CCIR Recommendations and Records, Geneve, 1982
- /3/ HARRIS : Instruction manual 7345-0009 (Antenna Coupler RF-615B)
- /4/ IEEE Std 145-1983: IEEE Standard Definitions of Terms for Antennas, New York, 1983
- /5/ Zuhrt, Harry: Elektromagnetische Strahlungsfelder, Springer, 1953
- /6/ Jordan, E. and Balmain, K.: Electromagnetic waves and radiating systems, Prentice-Hall, 1968
- /7/ Johnson, E. and Jasik, H: Antenna engineering handbook, McGraw-Hill, New York, 1961

A P P E N D I X B

Computer Programs

```
10  ! *****
20  ! *
30  ! *      CALCULATION OF THE RADIATION PATTERN (TYPE-1)      *
40  ! *
50  ! *      (written for Hewlett Packard 9845B)      *
60  ! *
70  ! *****
80  !
90  !
100 !
110 ! OPTION BASE 1
120 ! A=7.5      !element length [m]
130 ! H=.23     !actual height of line current [m]
140 ! F=3E6     !frequency [Hz]
150 ! C=3E8     !light velocity [m/s]
160 ! DEG
170 ! La=C/F   !lambda [m]
180 ! B=360/La !beta [degree/m]
190 ! K=20     !element intersection
200 ! I0=1     !feeder current [A]
210 ! Im=I0/COS(B*A) !maximum current
220 ! Hm=H/La*I0 !maximum magnetic fieldstrength
230 ! DIM Hf(3,19,19)
240 ! PLOTTER IS "GRAPHICS"
250 ! GCLEAR
260 ! GRAPHICS
270 ! SCALE 0,19,0,Hm
280 ! M=0
290 ! LONG 5
300 ! FOR Phi=0 TO 90 STEP 5      !azimuth steps
310 ! GCLEAR
320 ! AXES 1,Hm/10
330 ! MOVE 10,Hm*.8
340 ! LABEL "Phi=";Phi;"Grad"
350 ! M=M+1
360 ! N=0
370 ! FOR Th=0 TO 90 STEP 5      !elevation steps
380 ! N=N+1
390 ! H1=0
400 ! H2=0
410 ! H3=0
420 ! H4=0
430 ! D1=A/K
440 ! FOR I=0 TO K      !sum of complex magnetic field
450 ! Y=I*D1      !strengths for each phi and theta
```

```
460 K1=COS(B*(A-Y))
470 D=Y*SIN(Th)*SIN(Phi)
480 D1=D+H*COS(Th)
490 D2=D-H*COS(Th)
500 H1=H1+K1*COS(B*D1)
510 H2=H2+K1*SIN(B*D1)
520 H3=H3-K1*COS(B*D2)
530 H4=H4-K1*SIN(B*D2)
540 NEXT I
550 Hn=D1/2/La*Ia
560 Hf(1,N,M)=D1/2/La*Ia*ABS(COS(Phi))*SQR((H1+H3)^2+(H2+H4)^2)
570 Hvr=H/La*Ia*SIN(Th)*COS(B*A*SIN(Th)*SIN(Phi))
580 Hvi=H/La*Ia*SIN(Th)*SIN(B*A*SIN(Th)*SIN(Phi))
590 Hvr=Hvr-H/La*SIN(Th)
600 Hhr=D1/2/La*Ia*COS(Th)*SIN(Phi)*(H1+H3)
610 Hhi=D1/2/La*Ia*COS(Th)*SIN(Phi)*(H2+H4)
620 Hf(2,N,M)=SQR((Hvr+Hhr)^2+(Hvi+Hhi)^2)
630 Hf(3,N,M)=SQR(Hf(1,N,M)^2+Hf(2,N,M)^2)
640 MOVK N,Hf(1,N,M)
650 LABEL "*"
660 MOVK N,Hf(2,N,M)
670 LABEL "+"
680 NEXT Th
690 NRXT Phi
700 !
710 ! *****
720 !
730 CREATE "AntDa",60 !store data on tape
740 ASSIGN #1 TO "AntDa"
750 MAT PRINT #1;Hf
760 ASSIGN * TO #1
770 END
```

```
10  ! *****
20  ! *
30  ! *      CALCULATION OF THE RADIATION PATTERN (TYPE-2)      *
40  ! *
50  ! *****
60  !
70  !
80  !
90  OPTION BASE 1
100 A=12          !element length [m]
110 H=.23        !actual height of line current [m]
120 F=3E6        !frequency [Hz]
130 C=3E8        !light velocity [m/s]
140 DEG
150 La=C/F       !lambda [m]
160 B=360/La     !beta [degree/m]
170 K=20        !element intersection
180 IO=1        !feeder current [A]
190 Im=10/COS(B*A) !maximum current
200 Hm=2*H/La*Im
210 DIM Hf(3,19,19)
220 PLOTTER IS "GRAPHICS"
230 GCLEAR
240 GRAPHICS
250 SCALE 0,19,0,Hm
260 M=0
270 LOG 5
280 !
290 FOR Phi=0 TO 90 STEP 5      !azimuth steps
300 GCLEAR
310 AXES 1,Hm/10
320 MOVE 10,Hm*.8
330 LABEL "Phi=";Phi;"Grad"
340 M=M+1
350 N=0
360 !
370 FOR Th=0 TO 90 STEP 5      !elevation steps
380 N=N+1
390 H1=0
400 D1=A/K*2
410 !
420 FOR I=0 TO K                !vector sum of magnetic
430 Y=I*D1-A                    !fieldstrengths
440 K1=COS(B*(A-ABS(Y)))
450 D=Y*SIN(Th)*SIN(Phi)+H*COS(Th)
460 H1=H1+K1*SIN(B*D)
470 NEXT I
480 !
```

```
490 Hf(1,N,M)=D1/La*Im*ABS(COS(Phi)*H1)
500 Hf(2,N,M)=D1/La*Im*ABS(SIN(Phi)*COS(Th)*H1)+
    H/La*Im*2*ABS(SIN(Th)*SIN(B*A*SIN(Th)*SIN(Phi)))

510 Hf(3,N,M)=SQR(Hf(1,N,M)^2+Hf(2,N,M)^2)
520 MOVE N,Hf(1,N,M)
530 LABEL "*"
540 MOVE N,Hf(2,N,M)
550 LABEL "+"
560 NEXT Th
570 ! -----
580 NEXT Phi
590 ! -----
600 CREATE "AntDn",60 !store data on tape
610 ASSIGN #1 TO "AntDn"
620 MAT PRINT #1;Hf
630 ASSIGN * TO #1
640 END
```

```
10  ! *****
20  ! *
30  ! *      CALCULATION OF THE RADIATION RESISTANCE      *
40  ! *
50  ! *      (Needs data from radiation pattern)          *
60  ! *
70  ! *****
80  !
90  !
100 OPTION BASE 1
110 DIM H(3,19,19)
120 ASSIGN #1 TO "AntDa"
130 MAT READ #1;H      !reading data from tape
140 ASSIGN * TO #1
150 RAD
160 D=5*PI/180
170 Z=120*PI          !intrinsic impedance
180 Rs=0
190 !
200 ! ***** numeric integration of the power density *****
210 ! -----
220 FOR M=1 TO 19
230 R=0
240 ! -----
250 FOR N=1 TO 19
260 R=R+H(3,N,M)^2*SIN((N-1)*D)*D
270 NEXT N
280 ! -----
290 Rs=Rs+R*D
300 NEXT M
310 ! -----
320 Rs=Rs*4*Z
330 PRINTER IS 0
340 PRINT "Radiation resistance Rs =";Rs;" Ohm"
350 END
```

```
10 ! *****
20 ! *
30 ! *          CALCULATION OF THE TOTAL ANTENNA EFFICIENCY          *
40 ! *
50 ! *          (Antenna type 2)
60 ! *
70 ! *
80 ! *****
90 !
100 !
110 !
120 !
130 PRINTER IS 16
140 FIXED 2
150 PRINT PAGE
160 OPTION BASE 1
170 DIM L(101),R(101),C(101)
180 Clmin=1.2E-11 ! Couplercapacity C1 minimum/[F]
190 Clmax=5.00E-10 ! Couplercapacity C1 maximum/[F]
200 C22=2.00E-10 ! Couplercapacity C2 /[F]
210 Lmin=1E-6 ! Couplerinductivity minimum/[H]
220 Lmax=5.0E-5 ! Couplerinductivity maximum/[H]
230 Scu=5.8K7 ! Conductivity of Cu/[S/m]
240 Sal=3.0E7 ! Conductivity of Al/[S/m]
250 Hmax=.23 ! Maximum antenna height/[m]
260 A=12 ! Element length/[m]
270 D=2.0E-2 ! Antenna diameter/[m]
280 C=3E8
290 MO=4*PI*1E-7 ! Permittivity
300 Er=1.2 ! Epsilon(rel.) of coaxial feeder line
310 Zl=50 ! characteristic impedance of feeder line/[Ohms]
320 Da=1.7E-2 ! Diameter of outer conductor of the feeder line/[m]
330 Di=Da*KXP(-Zl*SQR(Er)/60)
340 Lt=A ! Length of coaxial line/[m]
350 Rq=50 ! Source resistance/[Ohm]
360 P0=100 ! Available generator power/[W]
370 !
380 ! ***** contact resistances*****
390 !
400 Rc1=2.0E-2
410 Rc2=2.0E-2
420 Rc5=2.0E-2
430 Rc6=2.0E-2
440 !
450 ! ***** Transformer T *****
460 !
470 Rsoll=Rq/4
480 RAD
490 !
500 ! ***** Q-factor of the variable coil *****
510 !
```

```
520 Q1=380
530 INPUT "frequency/[MHz]: ",F
540 IF (F<6) AND (F>2) THEN 590
550 DISP "frequency not correct!"
560 BEEP
570 WAIT 2000
580 GOTO 530
590 F=F*1E6
600 Om=2*PI*F
610 Q0=Q1*SQR(F/5E6)          ! actual Q-factor
620 B0=-1/Om/Lmax
630 H=SQR(Hmax*(Hmax-D))    ! height of line current
640 H1=Hmax-D/2             ! centre of antenna element
650 La=C/F                  ! wavelength
660 Be=2*PI/La              ! phase velocity
670 P=Be*A
680 W=2*P
690 Rv=A/D/3*SQR(F*M0/PI/Sal)*H1/H*(W+SIN(W))/W/COS(P)^2  ! loss resistance
700 Xa=60*LOG(2*(H1+H)/D)*TAN(P)  ! imaginary part of antenna impedance
710 Z0=120*PI
720 Rs=1.3*16*PI/3*Z0*(H/La*TAN(P))^2  ! approximated radiation resistance
730 Bee=Be/SQR(Er)          ! phase velocity inside feeder line
740 L0=ATN(Xa/Z1)/Bee      ! fictitious length
750 !
760 ! ***** losses of feeder line *****
770 !
780 Ro=SQR(F*M0/Scu/PI)*(1/Di+1/Da)
790 Rvc=Ro/4/Bee/COS(Bee*L0)^2*(2*Bec*Lt-SIN(2*Bee*L0)+SIN(2*Bee*(L0+Lt)))
800 !
810 ! ***** antenna impedance including losses **
820 !
830 R6=Rvc+Rs+Rv+Rc5
840 X6=Xa
850 ! *****
860 CALL Div(1,0,R6,X6,G6,B6)  ! antenna admittance
870 T=TAN(Bee*Lt)
880 ! ***** transformation of feeder line *****
890 CALL Mul(0,T,R6/Z1,X6/Z1,Nr,Ni)
900 CALL Div(R6,X6+Z1*T,1+Nr,Ni,R5,X5)
910 ! *****
920 R5=R5+Rc5  ! contact resistance coupler - feeder
930 CALL Div(1,0,R5,X5,G5,B5)
940 PRINTER IS 0
950 PRINT "
-----"
960 PRINT " INPUT DATA:   f = ";F*1E-6;" MHz   a = ";A;" m       d = ";D*100;
" cm"
970 PRINT "               max. Q-factor: Q0 = ";Q0;" when: L = Lmax"
980 PRINT "-----"
990 PRINT "height of line current:           h = ";H*100;" cm"
1000 PRINT "radiation resistance:           Rs = ";INT(1000*Rs+.5);" mOhm"
```

```
"
1010 PRINT "loss resistance of antenna:           Rv = ";INT(1000*Rv+.5);" mOhm
"
1020 PRINT "loss resistance of feeder line:       Rl = ";INT(1000*Rvc+.5);" mOh
"
1030 PRINT "imaginary part of antenna impedance:  Xa = ";INT(10*Xa+.5)/10;" Ohm
"
1040 PRINT "coaxial input impedance:             R5 = ";INT(1000*R5+.5)/1000;"
Ohm"
1050 PRINT "                                       X5 = ";INT(1000*X5+.5)/1000;"
Ohm"
1060 PRINT "contact resistances (C1,C2,ant.-coax,coax-coupler: ";Rc1*1000;" |mO
hm]"
1070 PRINT "-----"
"
1080 PRINT LIN(3)
1090 Durchl=0
1100 !
1110 ! ***** relay contact par. C2 open or closed *****
1120 !
1130   FOR S2=1 TO 2           ! open: S2=2, closed: S2=1
1140   ON S2 GOTO 1150,1170
1150   X45=0
1160   GOTO 1180
1170   X45=-1/Om/C22
1180   R4=R5+Rc2           ! contact resistance at C2 or relay
1190   X4=X5+X45
1200   CALL Div(1,0,R4,X4,G4,B4) ! admittance
1210   Z=0
1220   !
1230   ! ***** rough tuning of inductance L *****
1240   !
1250     FOR I=0 TO 100
1260     L=Lmin+I*(Lmax-Lmin)/100
1270     B1=-1/Om/L
1280     G1=-B1/Q0*SQR(B1/B0) ! loss conductance of inductance L
1290     CALL Refl(G4,B4,G1,B1,Rb,C1,C1min,C1max,Rc1,Rsol1,Om)
1300     IF Rb>.995 THEN 1350
1310     Z=Z+1
1320     R(Z)=Rb
1330     L(Z)=L
1340     C(Z)=C1
1350     NEXT I
1360   ! *****
1370   !
1380   ! ***** supervision of tuning *****
*
1390   !
1400   PLOTTER IS "GRAPHICS"
1410   GCLEAR
1420   GRAPHICS
1430   SCALE 5,59,-.095,1.05
```

```
1440 STANDARD
1450 CSIZE 2.8
1460 AXES 10,.1
1470 LONG 5
1480 ! -----
1490     FOR I=10 TO 50 STRP 10
1500     MOVE I,-.05
1510     LABEL I
1520     NEXT I
1530 ! -----
1540     FOR I=1 TO 10
1550     MOVE -2.5,1/10
1560     LABEL I/10
1570     NEXT I
1580 ! -----
1590     MOVE 3,.75
1600     CSIZE 3.3
1610     LABEL ":r:"
1620     MOVK 3,.7
1630     LABEL "^"
1640     MOVK 3,.68
1650     LABEL ":"
1660     MOVE 3,.66
1670     LABEL ":"
1680     MOVE 45,.04
1690     LABEL "--> L/uH"
1700     CSIZE 2.8
1710     MOVE 45,.36
1720     LABEL "**SWR=2**"
1730 ! -----
1740     FOR I=1 TO Z
1750     MOVE L(I)*1E6,R(I)
1760     LABEL "+"
1770     NEXT I
1780 ! -----
1790     LINE TYPE 4
1800     MOVK 1,1
1810     DRAW 50,1
1820     MOVE 50,0
1830     DRAW 50,1
1840     MOVE 1,0
1850     DRAW 1,1
1860     LINE TYPE 6
1870     MOVE 1,1/3
1880     DRAW 50,1/3
1890     LINE TYPE 1
1900     MOVE 40,1.025
1910     ON S2 GOTO 1920,1940
1920     LABEL "C2: short-circuit"
1930     GOTO 1950
1940     LABEL "C2 = 200 pF"
```

```
1950   Minr=l
1960   IF Z=0 THEN 3430
1970   !
1980   ! ***** fine tuning of inductance L *****
1990   !
2000       FOR I=l TO Z           ! searching minimum SWR
2010       IF R(I)>Minr THEN 2050
2020       Minr=R(I)
2030       Lminr=L(I)
2040       Minc=C(I)
2050       NEXT I
2060   ! -----
2070   Step=0
2080   IF Minr<.001 THEN 2350           ! tuning successfull?
2090   Step=Step+1
2100   IF Step>20 THEN 3430
2110   IF (Step=20) AND (Minr<=1/3) THEN 2350   ! tuning acceptable?
2120   Kl=lE-6
2130   Ul=Lminr-Kl/Step
2140   Ol=Lminr+Kl/Step
2150   IF Ul>Lmin THEN GOTO 2170
2160   Ul=Lmin           ! lower limitation
2170   IF Ol<Lmax THEN GOTO 2190
2180   Ol=Lmax           ! upper limitation
2190   St=2*Kl/Step
2200   ! -----
2210       FOR I=Ul TO Ol STEP St
2220       B1=-1/Om/I
2230       G1=-B1/Q0*SQR(B1/B0)
2240       CALL Refl(G4,B4,G1,B1,Rb,C1,Clmin,Clmax,Rcl,Rsol1,Om)
2250       IF Rb>Minr THEN 2290
2260       Minr=Rb
2270       Lminr=I
2280       Minc=C1
2290       NEXT I
2300   ! -----
2310   MOVE I*1E6,Rb
2320   LABEL "O"
2330   GOTO 2080
2340   !
2350   ! ***** calculation of impedances and admittances *****
2360   !
2370   C1=Minc
2380   L=Lminr
2390   Rb=Minr
2400   X23=-1/Om/C1
2410   B1=-1/Om/L
2420   PRINT LIN(3)
2430   PRINT "-----"
2440   FIXED 2
2450   G1=-B1/Q0*SQR(B1/B0)
```

```
2460 G3=G4+G1
2470 B3=B4+B1
2480 CALL Div(1,0,G3,B3,R3,X3)
2490 S2=R3+Rc1
2500 X2=X3+X23
2510 CALL Div(1,0,R2,X2,G2,B2)
2520 P1=P0*(1-Rb^2) ! power delivered to the coupler
2530 Swr=(1+Rb)/(1-Rb) ! standing wave ratio
2540 ! ***** currents, voltages, and powers *****
2550 PRINT " input reflection coefficient: r = ";Rb
2560 PRINT " VSWR: s = ";Swr
2570 I2=SQR(2*P1/R2)
2580 U22=SQR(2*P1/G2)
2590 U23=I2*ABS(X23)
2600 P23=I2^2/2*ABS(X23)
2610 Pvc1=I2^2/2*Rc1
2620 P2=P1-Pvc1
2630 I3=SQR(2*P2/R3)
2640 U33=SQR(2*P2/G3)
2650 P33=U33^2/2*ABS(R1)
2660 Pvl=U33^2/2*G1
2670 I1=U33*ABS(R1)
2680 P3=P1-Pvl
2690 I4=SQR(2*P3/R4)
2700 U44=SQR(2*P3/G4)
2710 U45=I4*ABS(X45)
2720 P45=I4^2/2*ABS(X45)
2730 Pvc2=I4^2/2*Rc2
2740 P4=P3-Pvc2
2750 U55=SQR(2*P4/G5)
2760 I5=SQR(2*P4/R5)
2770 Pvc5=I5^2/2*Rc5
2780 P5=P4-Pvc5
2790 I6=SQR(2*P5/R6)
2800 Pvc=I6^2/2*Rvc
2810 Pvc6=I6^2/2*Rc6
2820 Pv=I6^2/2*Rv
2830 Ps=I6^2/2*Rs
2840 ON S2 GOTO 2850,2870
2850 PRINT "capacitor C2: short-circuited"
2860 GOTO 2880
2870 PRINT "capacitor C2: C2 = 200 [pF]"
2880 PRINT "inductance L: L = ";L*1E6;" [uH]"
2890 PRINT "capacitor C1: C1 = ";C1*1E12;" [pF]"
2900 PRINT "-----"
2910 PRINT " impedances: Z2: R2 = ";R2;" [Ohm]; X2 = ";X2;" [Ohm]"
2920 PRINT " Z3: R3 = ";R3;" [Ohm]; X3 = ";X3;" [Ohm]"
2930 PRINT " Z4: R4 = ";R4;" [Ohm]; X4 = ";X4;" [Ohm]"
2940 PRINT " Z5: R5 = ";R5;" [Ohm]; X5 = ";X5;" [Ohm]"
2950 PRINT " Z6: R6 = ";R6;" [Ohm]; X6 = ";X6;" [Ohm]"
2960 PRINT "-----"
```

```
-----
2970 PRINT " admittances: Y2: G2 = ";G2*1000;" [mS]; B2 = ";B2*1000;"
[mS]"
2980 PRINT " Y3: G3 = ";G3*1000;" [mS]; B3 = ";B3*1000;"
[mS]"
2990 PRINT " Y4: G4 = ";G4*1000;" [mS]; B4 = ";B4*1000;"
[mS]"
3000 PRINT " Y5: G5 = ";G5*1000;" [mS]; B5 = ";B5*1000;"
[mS]"
3010 PRINT " Y6: G6 = ";G6*1000;" [mS]; B6 = ";B6*1000;"
[mS]"
3020 PRINT "-----
"
3030 PRINT " antenna: lmax = ";l6/COS(Be*A);" [A]"
3040 PRINT " feeder line: fictitious length l0 = ";L0;" [m]"
3050 PRINT " lmax = ";l6/COS(Be*L0);" [A]; Ort: lmax = ";P
I/Be-L0;" [m]"
3060 PRINT " Umax = ";l6/COS(Be*L0)*Zl;" [V]"
3070 PRINT "-----
"
3080 PRINT " available generator power: Pa = ";P0;" [Watt]"
3090 PRINT " power, delivered to coupler: Pl = ";P1;" [Watt]"
3100 PRINT "-----
"
3110 PRINT " currents: I2 = ";I2;" [A]"
3120 PRINT " I3 = ";I3;" [A]"
3130 PRINT " I4 = ";I4;" [A]"
3140 PRINT " I5 = ";I5;" [A]"
3150 PRINT " I6 = ";I6;" [A]"
3160 PRINT " I33 = ";I1;" [A]"
3170 PRINT "-----
"
3180 PRINT " voltages: U22 = ";U22;" [V]"
3190 PRINT " U23 = ";U23;" [V]"
3200 PRINT " U33 = ";U33;" [V]"
3210 PRINT " U44 = ";U44;" [V]"
3220 PRINT " U45 = ";U45;" [V]"
3230 PRINT " U55 = ";U55;" [V]"
3240 PRINT " U66 = ";l6*Xa;" [V]"
3250 PRINT "-----
"
3260 PRINT " reactive powers: P(Cl) = ";P23;" [W]"
3270 PRINT " P(L) = ";P33;" [W]"
3280 PRINT " P(C2) = ";P45;" [W]"
3290 PRINT " P(Xa) = ";l6^2/2*Xa;" [W]"
3300 PRINT "-----
"
3310 PRINT " dissipative powers: Pv(L) = ";Pv1;" [W]"
3320 PRINT " Pv(line) = ";Pvc;" [W]"
3330 PRINT " Pv(rad) = ";Pv;" [W]"
3340 PRINT " Pv (Cl) = ";Pvc1;" [W]"
3350 PRINT " Pv (C2) = ";Pvc2;" [W]"
```

```
3360 PRINT " feeder-antenna Pv = ";Pvc6;" [W]"
3370 PRINT " coupler-feeder Pv = ";Pvc5;" [W]"
3380 PRINT "
-----"
3390 PRINT " finally radiated power: Ps = ";Ps;" [W]"
3400 PRINT "
-----"
3410 PRINT LIN(2)
3420 Durchl=Durchl+1
3430 NEXT S2
3440 !
3450 ! *****
*
3460 !
3470 !
3480 !
3490 IF Durchl=0 THEN 3530
3500 EXIT GRAPHICS
3510 DISP " R E A D Y "
3520 GOTO 3590
3530 PRINTER IS 16
3540 EXIT GRAPHICS
3550 PRINT LIN(5)
3560 PRINT " N O T T U N A B L E "
3570 PRINTER IS 0
3580 PRINT "antenna not tunable"
3590 END
3600 !
3610 !
3620 !
3630 !
3640 !
3650 ! ***** SUBPROGRAMS *****
3660 !
3670 !
3680 !
3690 !
3700 !
3710 ! ***** complex multiplication *****
3720 !
3730 SUB Mul(Ar,Ai,Br,Bi,Cr,Ci)
3740 Cr=Ar*Br-Ai*Bi
3750 Ci=Ar*Bi+Ai*Br
3760 SUBEND
3770 !
3780 !
3790 ! ***** complex division *****
3800 !
3810 SUB Div(Ar,Ai,Br,Bi,Cr,Ci)
3820 N=Br^2+Bi^2
3830 Cr=(Ar*Br+Ai*Bi)/N
3840 Ci=(-Ar*Bi+Ai*Br)/N
```

```
3850 SUBEND
3860 !
3870 !
3880 ! ***** reflection coefficient of coupler *****
3890 !
3900 SUB Refl(G4,B4,G1,B1,Rb,C1,C1min,C1max,Rc1,Rsoll,Om)
3910 G3=G4+G1
3920 B3=B4+B1
3930 CALL Div(1,0,G3,B3,R3,X3)
3940 X23=-X3
3950 C1=-1/Om/X23
3960 IF (C1>C1min) AND (C1<=C1max) THEN 4010
3970 IF C1>C1max THEN 4000
3980 C1=C1min
3990 GOTO 4010
4000 C1=C1max
4010 X23=-1/Om/C1
4020 R2=R3+Rc1
4030 X2=X3+X23
4040 Rb=(R2-Rsoll)^2+X2^2
4050 Rb=SQR(Rb/((R2+Rsoll)^2+X2^2))
4060 SUBEND
4070 ! *****
```

```
10 ! *****
20 ! *
30 ! *      CALCULATION OF THE TUNED ANTENNA'S BANDWIDTH      *
40 ! *
50 ! *      (ANTENNA TYPE 1)
60 ! *
70 ! *****
80 !
90 !
100 !
110 PRINTER IS 16
120 STANDARD
130 PRINT PAGE
140 OPTION BASE 1
150 DIM I(101),R(101),C(101),Eta(2,82),Rf(2,82)
160 ! ***** antenna data *****
170 Clmin=1.2E-11
180 Clmax=5.00E-10
190 C22=2.00E 10
200 Lmin=1E-6
210 Lmax=5.0K-5
220 Scu=5.8E7
230 Sal=3.0K7
240 Hmax=.23
250 A=7.5
260 C=3E8
270 MO=4*PI*1E-7
280 Er=1.2
290 Z1=50
300 Da=1.7E-2
310 Di=Da*EXP(-Z1/60)
320 Lt=A
330 Rq=50
340 PO=100
350 A2=1.5
360 Rc1=2.0E-2
370 Rc2=2.0E-2
380 Rc5=2.0E-2
390 Rc6=2.0E-2
400 Rsol1=Rq/4
410 RAD
420 Q1=300
430 D=7.5E-2
440 ! -----
450 FOR F1=3 TO 5          ! centre frequency [MHz]
460   Kont=0
470   ! -----
480   FOR If=0 TO 81      ! frequency deviation +/- 10 kHz
490     Df=If-41
500     Kont=Kont+1
510     F=F1*1E6+Df*1000/4*(If>0)
520     Om=2*PI*F
```

```
530 Q0=Q1*SQR(F/3E6)
540 B0=-1/Om/Lmax
550 ! -----
560 H=SQR(Hmax*(Hmax-D))      ! antenna impedance
570 H1=Hmax-D/2
580 La=C/F
590 Be=2*PI/La
600 P=Be*A
610 W=2*P
620 Rv=A/D/6*SQR(F*M0/PI/Sal)*H1/H*(W+SIN(W))/W/COS(P)^2
630 Za=60*LOG(2*(H1+H)/D)
640 Xa=Za*TAN(P)
650 Z0=120*PI
660 Rs=4/3*PI*Z0*(H*F*TAN(Be*A)/C)^2
670 R6=Rs+Rv
680 X6=Xa
690 CALL Div(1,0,R6,X6,G6,B6)
700 Bp=TAN(Be*A2)/Za
710 R6=B6+Bp
720 CALL Div(1,0,G6,B6,R6,X6)
730 R5=R6+Rc5
740 X5=X6
750 CALL Div(1,0,R5,X5,G5,B5)
760 ! -----
770 Durchl=0      ! coupler tuning to centre frequency
780 IF Kont>1 THEN GOTO 1600
790 S2=2
800 Ps=0
810 ON S2 GOTO 820,840
820 X45=0
830 GOTO 850
840 X45=-1/Om/C22
850 R4=R5+Rc2
860 X4=X5+X45
870 CALL Div(1,0,R4,X4,G4,B4)
880 Z=0
890 FOR I=0 TO 100
900 L=Lmin+I*(Lmax-Lmin)/100
910 B1=-1/Om/L
920 G1=-B1/Q0*SQR(B1/B0)
930 CALL Refl(G4,B4,G1,B1,Rb,C1,C1min,C1max,Rc1,Rsoll,Om)
940 IF Rb>.995 THEN 990
950 Z=Z+1
960 R(Z)=Rb
970 L(Z)=L
980 C(Z)=C1
990 NEXT I
1000 PLOTTER IS "GRAPHICS"
1010 GCLEAR
1020 GRAPHICS
1030 SCALE -5,59,-.09,1.1
1040 AXES 10,.1
```

```
1050  LORG 5
1060  MOVE 3,.8
1070  LABEL "r:"
1080  MOVE 45,.08
1090  LABEL "L/uH"
1100  FOR I=1 TO Z
1110  MOVE L(I)*1E6,R(I)
1120  LABEL "+"
1130  NEXT I
1140  LINE TYPE 4
1150  MOVE 50,0
1160  DRAW 50,1.1
1170  MOVE 0,1
1180  DRAW 60,1
1190  MOVE 10,0
1200  DRAW 10,1.1
1210  LINE TYPE 1
1220  MOVE 40,1.05
1230  ON S2 GOTO 1240,1260
1240  LABEL "C2: KS"
1250  GOTO 1270
1260  LABEL "C2 = 200 pF"
1270  Minr=1
1280  IF Z=0 THEN 2160
1290  FOR I=1 TO Z
1300  IF R(I)>Minr THEN 1340
1310  Minr=R(I)
1320  Lminr=L(I)
1330  Minc=C(I)
1340  NEXT I
1350  Step=0
1360  IF Minr<.001 THEN 1580
1370  Step=Step+1
1380  IF Step>40 THEN 2120
1390  IF (Step=40) AND (Minr<=1/3) THEN 1580
1400  K1=2E-6
1410  U1=Lminr-K1/Step^2
1420  O1=Lminr+K1/Step^2
1430  IF U1>Lmin THEN GOTO 1450
1440  U1=Lmin
1450  St=2*K1/Step^2
1460  FOR I=U1 TO O1 STEP St
1470  B1=-1/Om/I
1480  G1=-B1/Q0*SQR(B1/B0)
1490  CALL Refl(G4,B4,G1,B1,Rb,C1,Cmin,Cmax,Rcl,Rsol1,Om)
1500  IF Rb>Minr THEN 1540
1510  Minr=Rb
1520  Lminr=1
1530  Minc=C1
1540  NEXT I
1550  MOVE Lminr*1E6,Minr
1560  LABEL "O"
```

```
1570 GOTO 1360
1580 MOVE Lminr*1E6,Minr
1590 LABEL "O" ! end of tuning
1600 ! -----
1610 Cl=Minr ! impedances and admittances
1620 L=Lminr
1630 X23=-1/Om/Cl
1640 B1=-1/Om/L
1650 G1=-B1/Q0*SQR(R1/H0)
1660 R4=R5+Rc2
1670 X45=-1/Om/C22
1680 X4=X5+X45
1690 CALL Div(1,0,R4,X4,G4,B4)
1700 G3=G4+G1
1710 B3=B4+B1
1720 CALL Div(1,0,G3,B3,R3,X3)
1730 R2=R3+Rc1
1740 X2=X3+X23
1750 CALL Div(1,0,R2,X2,G2,B2)
1760 CALL Div(R2-Rsoll,X2,R2+Rsoll,X2,Rbr,Rbi)
1770 Rb=SQR(Rbr^2+Rbi^2)
1780 IF If<1 THEN GOTO 1800
1790 Rf(2,If)=Rb
1800 P1=P0*(1-Rb^2)
1810 Swr=(1+Rb)/(1-Rb)
1820 ! -----
1830 I2=SQR(2*P1/R2) ! currents, voltages and powers
1840 U22=SQR(2*P1/G2)
1850 U23=I2*ABS(X23)
1860 P23=I2^2/2*ABS(X23)
1870 Pvc1=I2^2/2*Rc1
1880 P2=P1-Pvc1
1890 I3=SQR(2*P2/R3)
1900 U33=SQR(2*P2/G3)
1910 P33=U33^2/2*ABS(B1)
1920 Pvl=U33^2/2*G1
1930 I1=U33*ABS(B1)
1940 P3=P1-Pvl
1950 I4=SQR(2*P3/R4)
1960 U44=SQR(2*P3/G4)
1970 U45=I4*ABS(X45)
1980 P45=I4^2/2*ABS(X45)
1990 Pvc2=I4^2/2*Rc2
2000 P4=P3-Pvc2
2010 U55=SQR(2*P4/G5)
2020 I5=SQR(2*P4/R5)
2030 Pvc5=I5^2/2*Rc5
2040 P5=P4-Pvc5
2050 I6=SQR(2*P5/R6)
2060 Pv=I6^2/2*Rv
2070 Ps=I6^2/2*Rs
2080 IF If<1 THEN GOTO 2130
```

```
2090 EXIT GRAPHICS
2100 Kta(S2,If)=Ps
2110 Durchl=Durchl+1
2120 Kta(S2,If)=Ps
2130 PRINTER IS 16
2140 PRINT "f = ";F/1E6;"MHz      Eta ";Ps;"%      SWR ";Swr
2150 PRINT "-----"
"
2160 NEXT If
2170 PLOTTER IS "GRAPHICS"      ! plot results
2180 GCLEAR
2190 GRAPHICS
2200 SCALE -10.5,10.5,-.06,1.15
2210 AXES 1,.1,0,0,5,5
2220 CSIZE 2.5
2230 LONG 6
2240 FOR I=-10 TO 10 STEP 2
2250 IF I=0 THEN 2280
2260 MOVE 1,-2.0E-2
2270 LABEL 1
2280 NEXT I
2290 LONG 4
2300 MOVE 7,2.0E-2
2310 LABEL "----> f/kHz"
2320 LONG 8
2330 FOR I=.2 TO 1 STEP .2
2340 MOVE -.4,I
2350 LABEL 1
2360 NEXT I
2370 LONG 2
2380 MOVE .5,1.05
2390 LABEL "P/Pmax"
2400 MOVE 5,1.05
2410 LABEL "f = ";F1;" MHz"
2420 LONG 5
2430 FOR J=2 TO 2
2440 Ref=Eta(2,41)
2450 MOVE -10,Eta(2,1)/Ref
2460 FOR I=-10 TO 10 STEP .25
2470 DRAW 1,Eta(J,4*I+41)/Ref
2480 NEXT I
2490 MOVE -10,Rf(2,1)
2500 LINE TYPE 2
2510 FOR I=-10 TO 10 STEP .25
2520 DRAW 1,Rf(2,4*I+41)
2530 NEXT I
2540 NEXT J
2550 DUMP GRAPHICS
2560 PRINTER IS 0
2570 PRINT LIN(5)
2580 PRINT "Antenna type-1: Kta(f)"
2590 PRINT "a ";A;" m; A1 ";A2;" m      d ";D*100;" cm"
```

```
2600 PRINT "Pmax = ";Ref;" Watt (Pa=100W)"
2610 PRINT LIN(5)
2620 NEXT Fl
2630 END
2640 ! -----
2650 SUB Mul(Ar,Ai,Br,Bi,Cr,Ci)          ! subroutines
2660 Cr=Ar*Br-Ai*Bi
2670 Ci=Ar*Bi+Ai*Br
2680 SUBEND
2690 SUB Div(Ar,Ai,Br,Bi,Cr,Ci)
2700 N=Br^2+Bi^2
2710 Cr=(Ar*Br+Ai*Bi)/N
2720 Ci=(-Ar*Bi+Ai*Br)/N
2730 SUBEND
2740 SUB Refl(G4,B4,G1,B1,Rb,C1,C1min,C1max,Rcl,Rsoll,Om)
2750 G3=G4+G1
2760 B3=B4+B1
2770 CALL Div(1,0,G3,B3,R3,X3)
2780 X23=-X3
2790 C1=-1/Om/X23
2800 IF (C1>=C1min) AND (C1<=C1max) THEN 2850
2810 IF C1>C1max THEN 2840
2820 C1=C1min
2830 GOTO 2850
2840 C1=C1max
2850 X23=-1/Om/C1
2860 R2=R3+Rcl
2870 X2=X3+X23
2880 Rb=(R2-Rsoll)^2+X2^2
2890 Rb=SQR(Rb/((R2+Rsoll)^2+X2^2))
2900 SUBEND
```

**END**

**FILMED**

*2-86*

**DTIC**