

12

AD-A163 046

AD



US ARMY
MATERIEL
COMMAND

TECHNICAL REPORT BRL-TR-2694

BLAST LOADING ON ABOVE GROUND
BARRICADED MUNITION STORAGE
MAGAZINES - II

George A. Coulter
Charles N. Kingery
Peter Muller

November 1985

SDTIC
ELECTED
JAN 09 1986
E

APPROVED FOR PUBLIC RELEASE; DISTRIBUTION UNLIMITED.

ERIC FILE COPY

US ARMY BALLISTIC RESEARCH LABORATORY
ABERDEEN PROVING GROUND, MARYLAND

86 1 9 025

Destroy this report when it is no longer needed.
Do not return it to the originator.

Additional copies of this report may be obtained
from the National Technical Information Service,
U. S. Department of Commerce, Springfield, Virginia
22161.

The findings in this report are not to be construed as an official
Department of the Army position, unless so designated by other
authorized documents.

The use of trade names or manufacturers' names in this report
does not constitute indorsement of any commercial product.

UNCLASSIFIED

SECURITY CLASSIFICATION OF THIS PAGE (When Data Entered)

REPORT DOCUMENTATION PAGE		READ INSTRUCTIONS BEFORE COMPLETING FORM
1. REPORT NUMBER Technical Report BRL-TR-2694	2. GOVT ACCESSION NO. AD-A163040	3. RECIPIENT'S CATALOG NUMBER
4. TITLE (and Subtitle) BLAST LOADING ON ABOVE GROUND BARRICADED MUNITION STORAGE MAGAZINES - II		5. TYPE OF REPORT & PERIOD COVERED Final
		6. PERFORMING ORG. REPORT NUMBER
7. AUTHOR(s) George A. Coulter Charles N. Kingery Peter Muller		8. CONTRACT OR GRANT NUMBER(s)
9. PERFORMING ORGANIZATION NAME AND ADDRESS US Army Ballistic Research Laboratory ATTN: SLCBR-TB-B Aberdeen Proving Ground, MD 21005-5066		10. PROGRAM ELEMENT, PROJECT, TASK AREA & WORK UNIT NUMBERS 4Z665805M857, IAO E8784L113
11. CONTROLLING OFFICE NAME AND ADDRESS USA Ballistic Research Laboratory ATTN: SLCBR-DD-T Aberdeen Proving Ground, MD 21005-5066		12. REPORT DATE November 1985
		13. NUMBER OF PAGES 114
14. MONITORING AGENCY NAME & ADDRESS (if different from Controlling Office)		15. SECURITY CLASS. (of this report) Unclassified
		15a. DECLASSIFICATION/DOWNGRADING SCHEDULE
16. DISTRIBUTION STATEMENT (of this Report) Approved for public release; distribution unlimited.		
17. DISTRIBUTION STATEMENT (of the abstract entered in Block 20, if different from Report)		
18. SUPPLEMENTARY NOTES This work was performed for and funded by the Department of Defense Explosives Safety Board, 2461 Eisenhower Ave., Alexandria, VA 22331.		
19. KEY WORDS (Continue on reverse side if necessary and identify by block number) Air Blast; Model Magazines Barricades; Munitions Storage Blast Waves; Pentolite; Blast Suppression; Scaling Techniques; Structural Loading.		
20. ABSTRACT (Continue on reverse side if necessary and identify by block number) This report presents the results of a study designed to measure the blast loading on above ground munition storage magazines. The magazines are sited at separation distances of K2 ($2W^{1/3}$ ft), K4 ($4W^{1/3}$ ft), and K6 ($6W^{1/3}$ ft) where W is the maximum allowable high-explosive weight in pounds mass. Earth barricades protect the structures. Responding and nonresponding 1/23.5 scaled models were used for the test program. Loading results are presented for the nonresponding barricaded model magazine. The highest loading measured on the nonresponding		

DD FORM 1 JAN 73 1473

EDITION OF 1 NOV 65 IS OBSOLETE

UNCLASSIFIED

SECURITY CLASSIFICATION OF THIS PAGE (When Data Entered)

UNCLASSIFIED

SECURITY CLASSIFICATION OF THIS PAGE(When Data Entered)

model was on the side-wall nearest the donor magazine. Maximum values of reflected pressure at Station 3 were found to be about 900, 600, and 360 kPa for separation distances of $0.8 Q^{1/3}$ m, $1.6 Q^{1/3}$ m, and $2.4 Q^{1/3}$ m, respectively. Whole wall translation velocities calculated from the measured wall loading forces ranged from 7-12 m/s. These velocities are well under the fragment velocities needed to cause detonation of the stored munitions in the acceptor magazine. This indicated the present siting criteria of $0.8 Q^{1/3}$ m is safe for this type of above ground barricaded magazine. Additional costly greater siting distances should not be necessary. *Magazines: -X target A)*

Accession For	
NTIS GRA&I	<input checked="" type="checkbox"/>
DTIC TAB	<input type="checkbox"/>
Unannounced	<input type="checkbox"/>
Justification	
By _____	
Distribution/	
Availability Codes	
Dist	Avail and/or Special
A-1	



UNCLASSIFIED

SECURITY CLASSIFICATION OF THIS PAGE(When Data Entered)

TABLE OF CONTENTS

	Page
LIST OF ILLUSTRATIONS.	5
LIST OF TABLES	7
I. INTRODUCTION	9
A. Background	9
B. Objective	9
II. TEST PROCEDURES	9
A. Models	9
B. Test Charges	12
C. Test Layout	12
D. Instrumentation	12
E. Test Matrix	20
III. RESULTS	21
A. Site Damage	21
B. Blast Loading on Acceptor Structure - Near Side-Wall .	21
C. Blast Loading on Acceptor Structure - Roof	33
D. Blast Loading on Acceptor Structure - Ends	33
E. Blast Loading on Acceptor Structure - Far Side-Wall .	33
IV. ANALYSIS	44
A. Blast Suppression Factors	44
B. Translation Velocity Predictions for Near Side-Wall. .	50
V. SUMMARY AND CONCLUSIONS	55
ACKNOWLEDGMENT	55
REFERENCES	56
APPENDIX	57
LIST OF FIGURES	59
DISTRIBUTION LIST.	105

LIST OF ILLUSTRATIONS

Figure	Page
1. Nonresponding Acceptor Model.	10
2. Concrete Donor/Acceptor Models	13
3. Concrete Responding Acceptor Model	14
4. Test Layout for a Separation Distance of $0.8 Q^{1/3}$ m	16
5. Test Layout for a Separation Distance of $1.6 Q^{1/3}$ m	17
6. Test Layout for a Separation Distance of $2.4 Q^{1/3}$ m	18
7. Data Acquisition/Reduction System	19
8. Photographs for a Separation Distance of $0.8 Q^{1/3}$ m (K2)	22
9. Photographs for a Separation Distance of $1.6 Q^{1/3}$ m (K4)	24
10. Photographs for a Separation Distance of $2.4 Q^{1/3}$ m (K6)	25
11. Pressure-Time Records, Free-Field with Barricades	27
12. Pressure-Time Records from Near Side-Wall, Station 1	31
13. Pressure-Time Records from Near Side-Wall, Station 3	32
14. Pressure-Time Records from the Roof, Station 13	35
15. Pressure-Time Records from the Roof, Station 14	36
16. Pressure-Time Records from the Roof, Station 16	37
17. Pressure-Time Records from Back End-Wall, Station 11	39
18. Pressure-Time Records from Front End-Wall, Station 18	40
19. Pressure-Time Records from Far Side-Wall, Station 8	42
20. Pressure-Time Records from Far Side-Wall, Station 9	43
21. Comparison of Standard Free-Field Pressures to Data from Stations 20 and 21	46
22. Comparison of Standard Free-Field Impulses to Data from Stations 20 and 21	47
23. Average Loading on Near Side-Wall	51
24. Predicted Translational Velocity of Near Side-Wall	54

LIST OF TABLES

Table	Page
1. Test Matrix	20
2. Free-Field Blast Parameters - with Barricades	26
3. Blast Loading on Near Side-Wall	30
4. Blast Loading on Roof	34
5. Blast Loading on End Walls	38
6. Blast Loading on Far Side-Wall	41
7. Suppression Effects on Pressure	48
8. Suppression Effects on Impulse	49
9. Translation of Near Side-Wall, Shot 1, $0.8 Q^{1/3}$ m	52
10. Translation of Near Side-Wall, Shot 2, $1.6 Q^{1/3}$ m	52
11. Translation of Near Side-Wall, Shot 5, $2.4 Q^{1/3}$ m	53

I. INTRODUCTION

A. Background

This study is a portion of a research program conducted at the Ballistic Research Laboratory (BRL) and sponsored by the Department of Defense Explosives Safety Board (DDESB). The purpose of the general program is to model and measure blast parameters pertaining to various types of munition storage magazines. This study concerns an above ground type barricaded storage magazine, but without earth cover. This type of magazine has been located in areas of Europe and in the United Kingdom. The particular one selected for study is located in Machrihanish, Scotland, Reference 1. Preliminary research at BRL was reported in Reference 2.

B. Objective

The primary objective of this phase of the research is to determine through scale model experiments, the blast loading on an acceptor magazine with differing barricades in the event of an accidental explosion in a donor magazine. An assumption is made that all the stored munition (net explosive weight, NEW) in the donor magazine detonates together to create the blast wave. Effects of the munitions casing are not considered, although, for the particular contents of a known storage magazine it could be included.

All barricades were constructed of hard packed soil. Results from Reference 2 indicated a need to control this parameter. Safe separation distances of $0.8 Q^{1/3}$ m, $1.6 Q^{1/3}$ m, and $2.4 Q^{1/3}$ m, where Q is in kilograms, were to be modeled with the experiments. These distances correspond to K2 ($2W^{1/3}$ ft), K4 ($4W^{1/3}$ ft) and K6 ($6W^{1/3}$ ft) where w is in pounds mass.

II. TEST PROCEDURES

The types of models, test site layout, instrumentation, and test matrix will be discussed in this section.

A. Models

Two types of scaled models were used for the test program. A steel nonresponding acceptor model was built and instrumented with piezoelectric pressure transducers. The second model was a scaled concrete model (density was same as full-size magazine) used both for the donor and the responding acceptor (Shot 1 only).

Figure 1 shows photographs and a sketch of the 1/23.5 scale nonresponding steel model of a munitions magazine located at the Machrihanish, Scotland site. The assumption is made that the variety of stored munitions in the full-sized magazine will be equivalent to 13,000 kg of bare hemispherical Pentolite. This amount is scaled down by the cube root or to 1/23.5 scale for the 1 kg charge that was used for these tests. The model dimensions and transducer locations are shown in Figure 1-C.

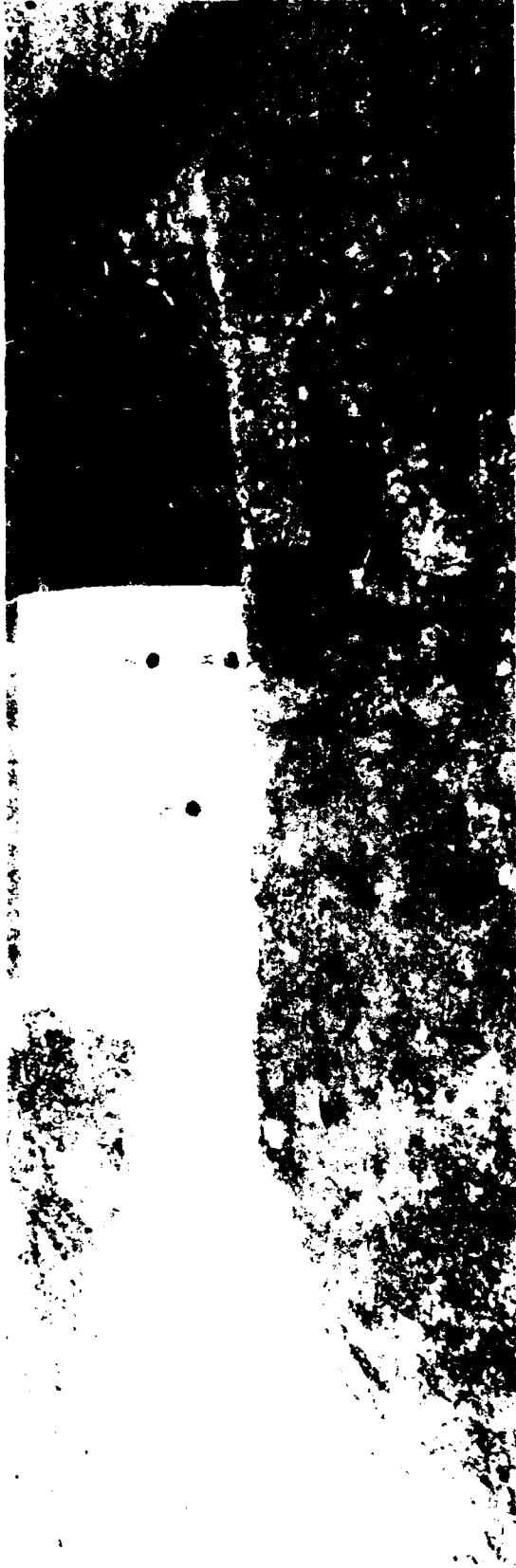

A. View of Back Side Wall

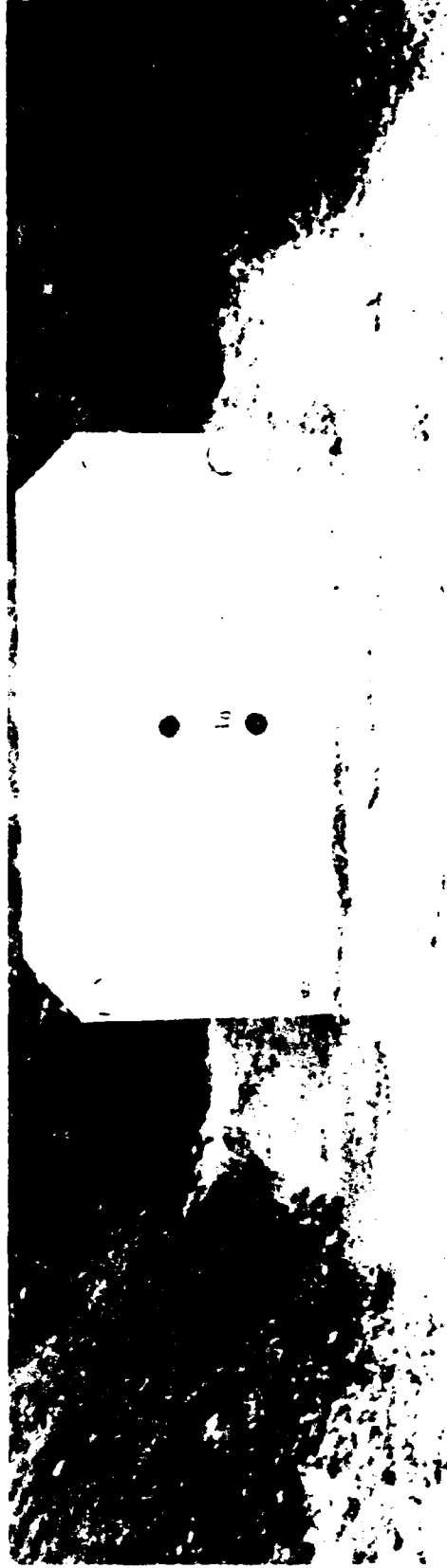

B. View of Right End Wall

Figure 1. Nonresponding Acceptor Model

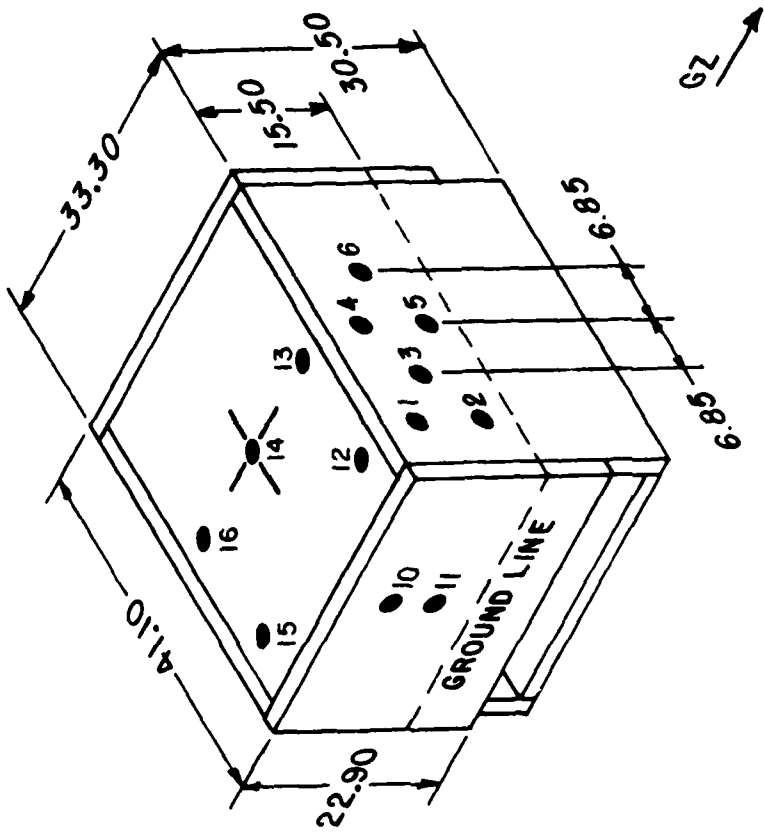

FRONT/TOP/L SIDE

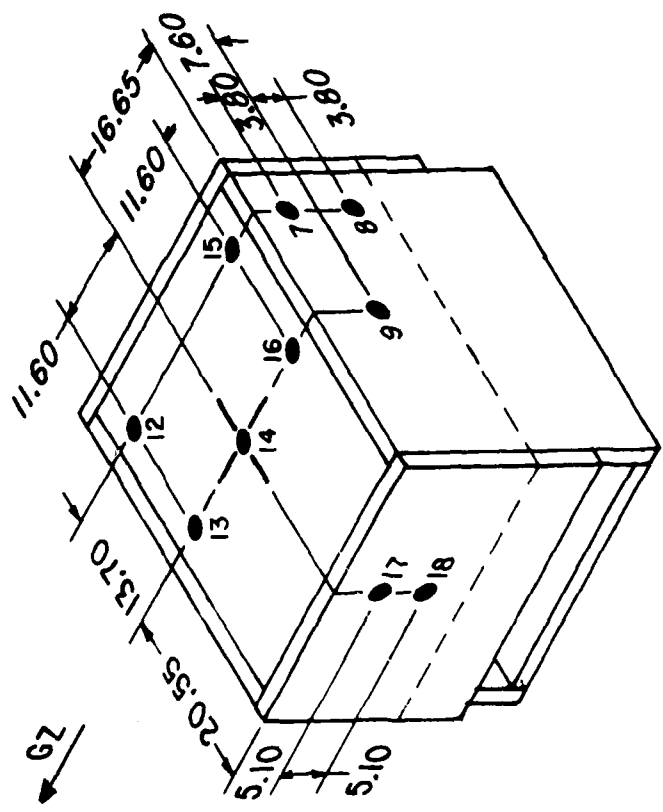

REAR/TOP/R SIDE

C. Sketch Showing Station Locations

Figure 1. Nonresponding Acceptor Model (Cont.)

The near side-wall is defined as the wall closest to the magazine. All positions are defined as seen from the donor magazine.

The concrete donor/acceptor model was also 1/23.5 scale; it is shown in the photographs of Figures 2 and 3. The concrete models were cast as five separate slabs. The door opening was closed during the shot by a cardboard door. A ready-mixed mortar cement was used for the roof and wall portions. Copper wire was used as reinforcing for the roof slab only.

For Shot 1, the responding acceptor model had the near side-wall scored to control the break-up mode. Additionally, the model slabs were cemented at the joints with silastic cement to insure that the side wall would fail first as would be expected for the full-size magazine.

A styrofoam witness plate was placed against the back wall to catch any flying fragments. A simple indication of the break-up pattern might be obtained in this manner. A more sophisticated velocity screen system is planned for use during future tests.

B. Test Charges

The bare charges were cast in-house with a 50/50 mix Pentolite in a hemispherical mold. All charges were trimmed to be exactly 1 kg. Detonation was from the center of the flat surface of the charge placed on the donor's floor.

C. Test Layout

Figures 4-6 show sketches of the test site layout. All dimensions, including barricades, were scaled by the 1/23.5 factor chosen for the model and the charge. It was decided at a meeting with the DDESB Project Officer not to change the spacing between the models and the back barricade. Spacing was changed between the model magazines according to multiples of the safe separations distances: $0.8 Q^{1/3}$ m, $1.6 Q^{1/3}$ m, and $2.4 Q^{1/3}$ m.

D. Instrumentation

The instrumentation was standard for blast wave recording. The transducers were quartz PCB piezoelectric type, Models 113A24 and 113A28. These were coupled through preamplifiers into either a Honeywell 7600 or 101 FM recording system. The data were available from a visicorder immediately after the shot. Later the data were reduced to plots with engineering units for comparison. An analog-digital system coupled to a microcomputer accomplished this phase of the data reduction. See Figure 7 for a schematic.



A. Donor without Roof Slab

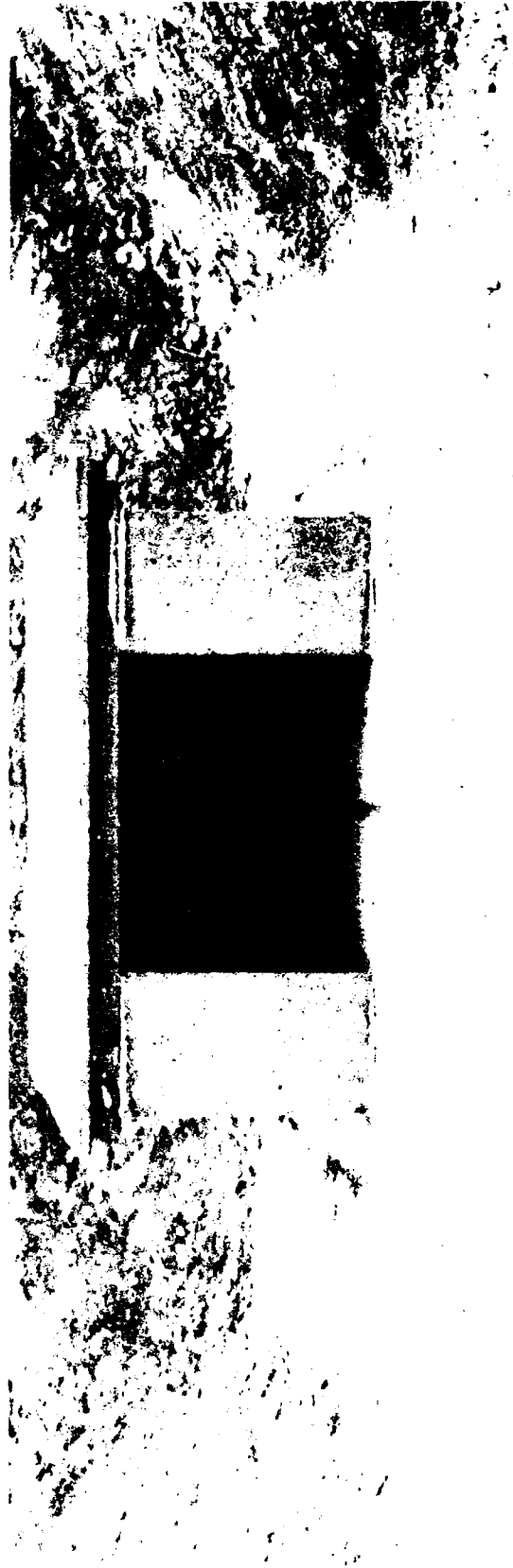

B. Acceptor

Figure 2. Concrete Donor/Acceptor Models



A. Scored Near Side-Wall

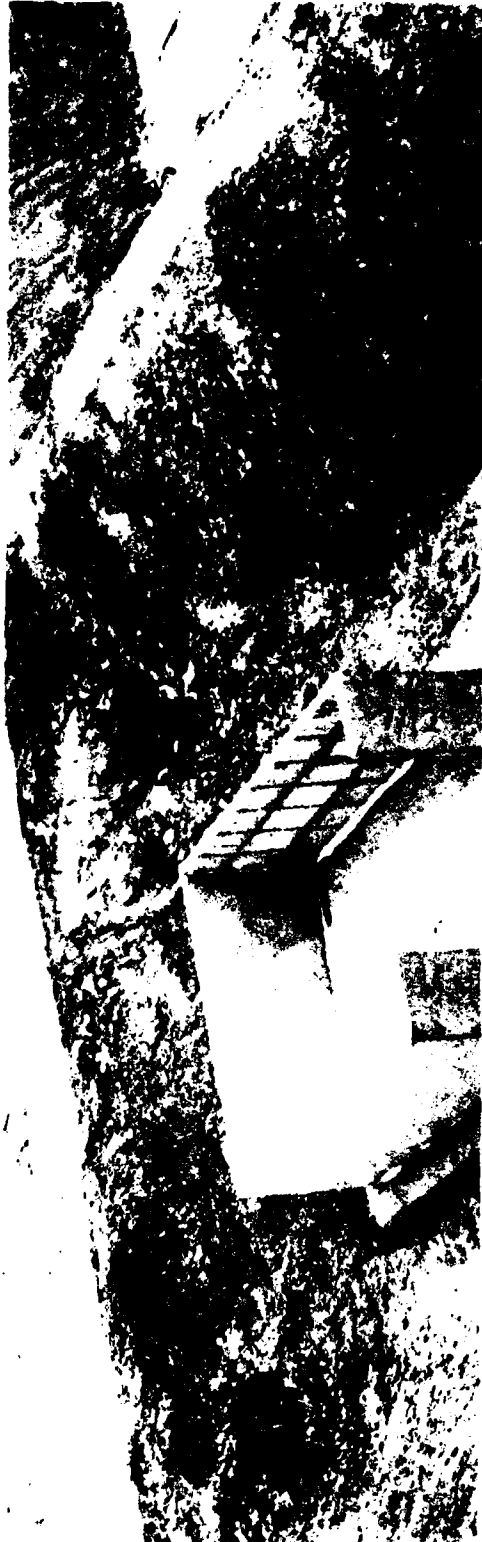

B. Installed Wall

Figure 3. Concrete Responding Acceptor Model

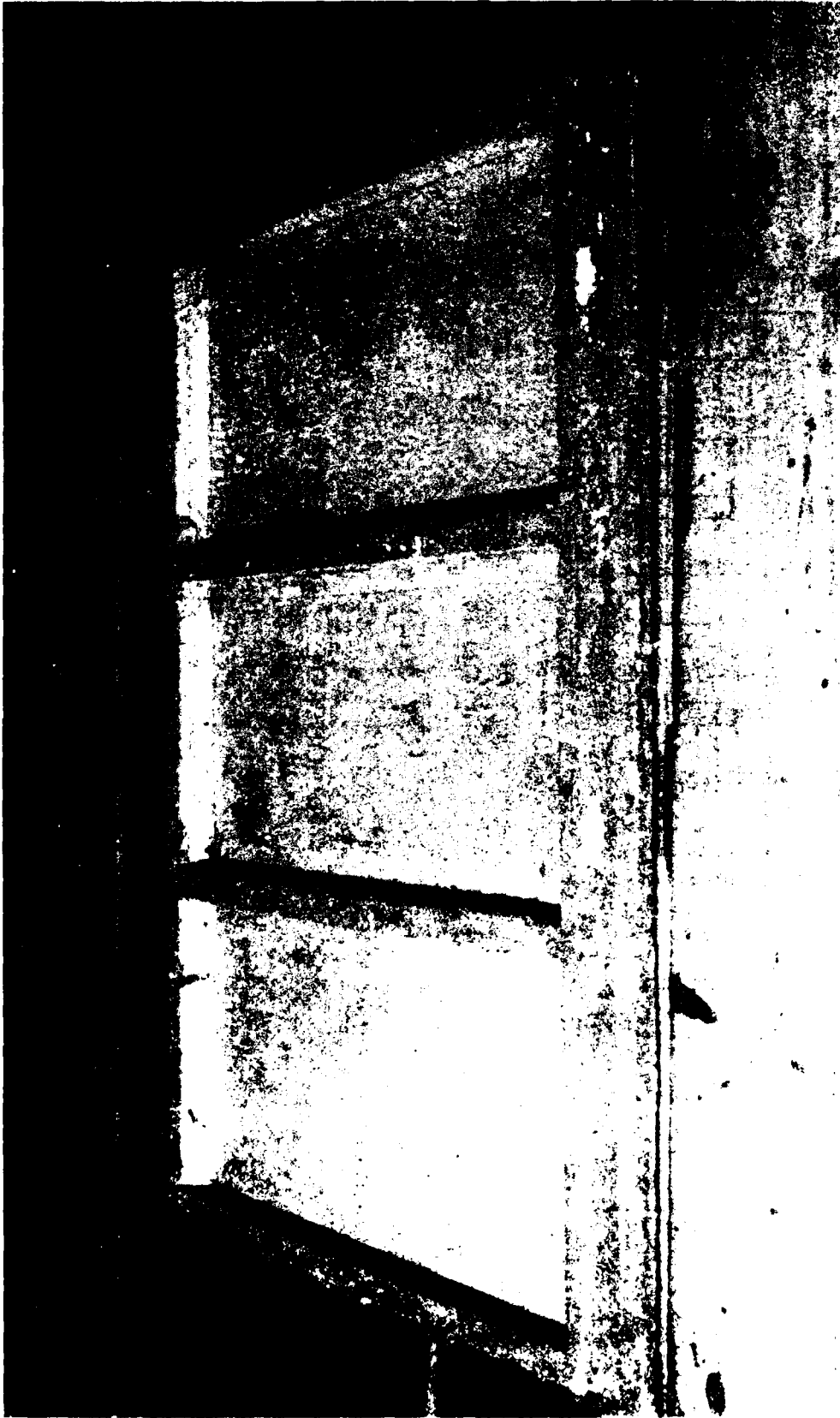

C. Reinforced Donor/Acceptor Roof

Figure 3. Concrete Responding Acceptor Model (Cont.)

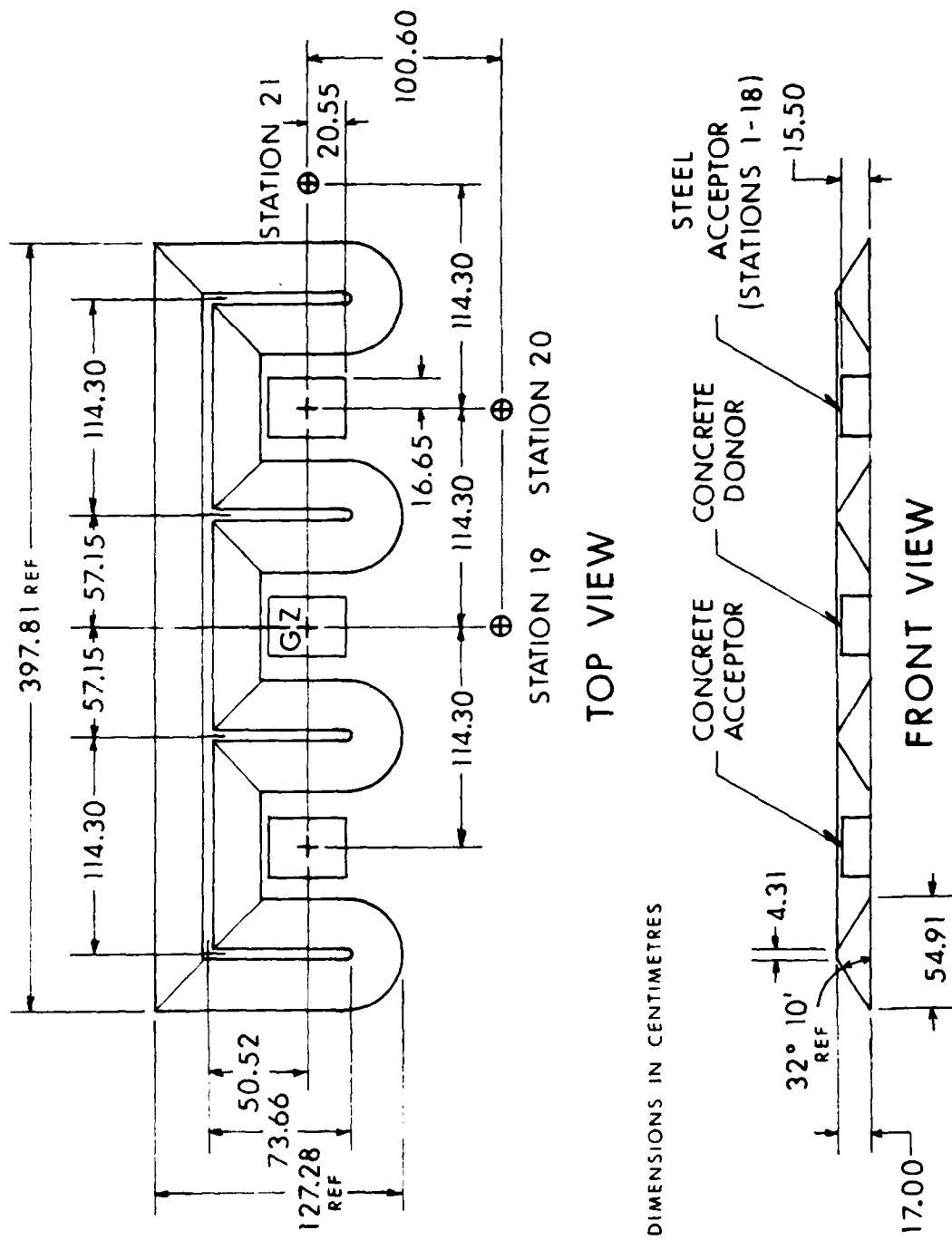

Figure 4. Test layout for a Separation Distance of $0.8 Q^{1/3}$ m

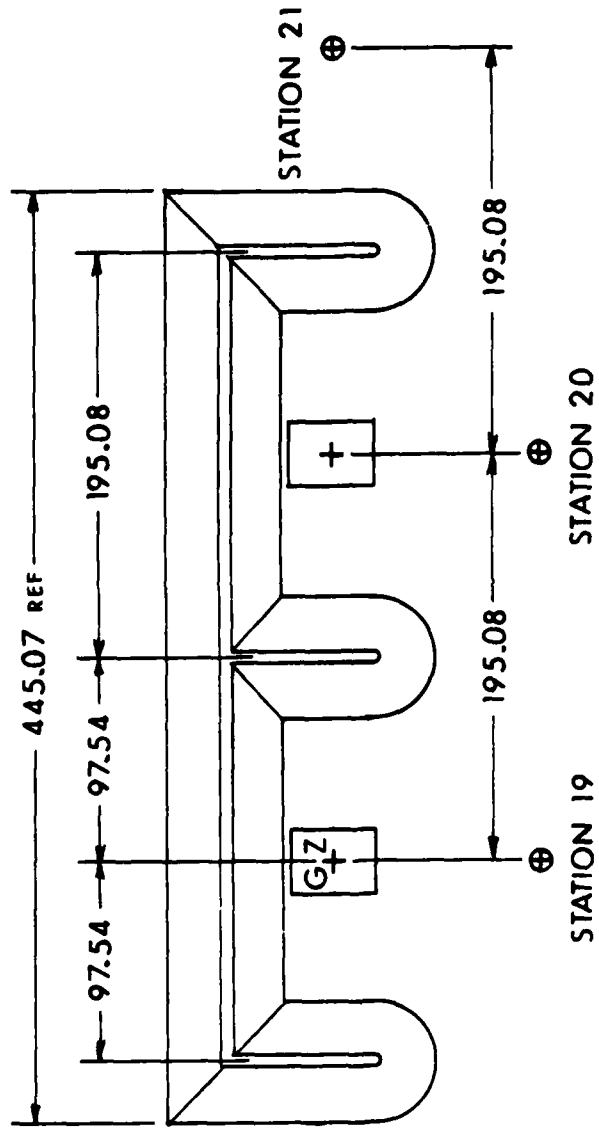

Figure 5. Test Layout for a Separation Distance of $1.6 Q^{1/3}$ m

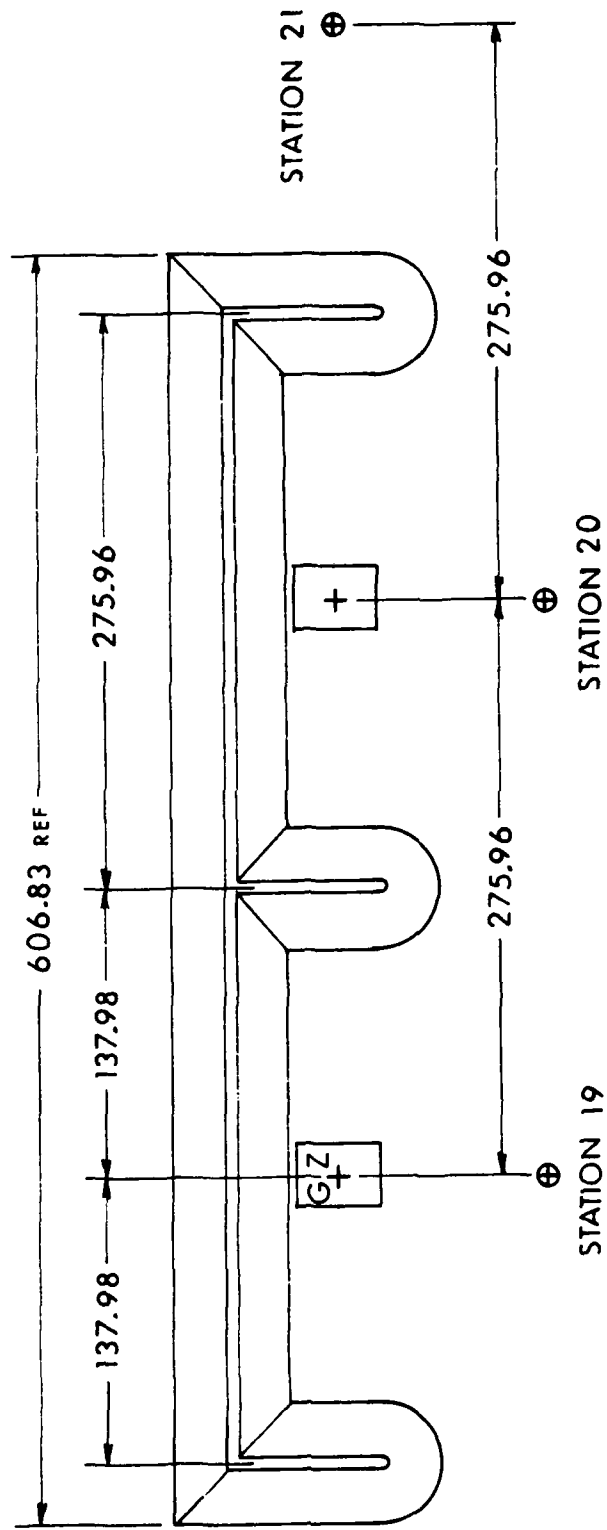

Figure 6. Test Layout for a Separation Distance of $2.4 Q^{1/3}$ m

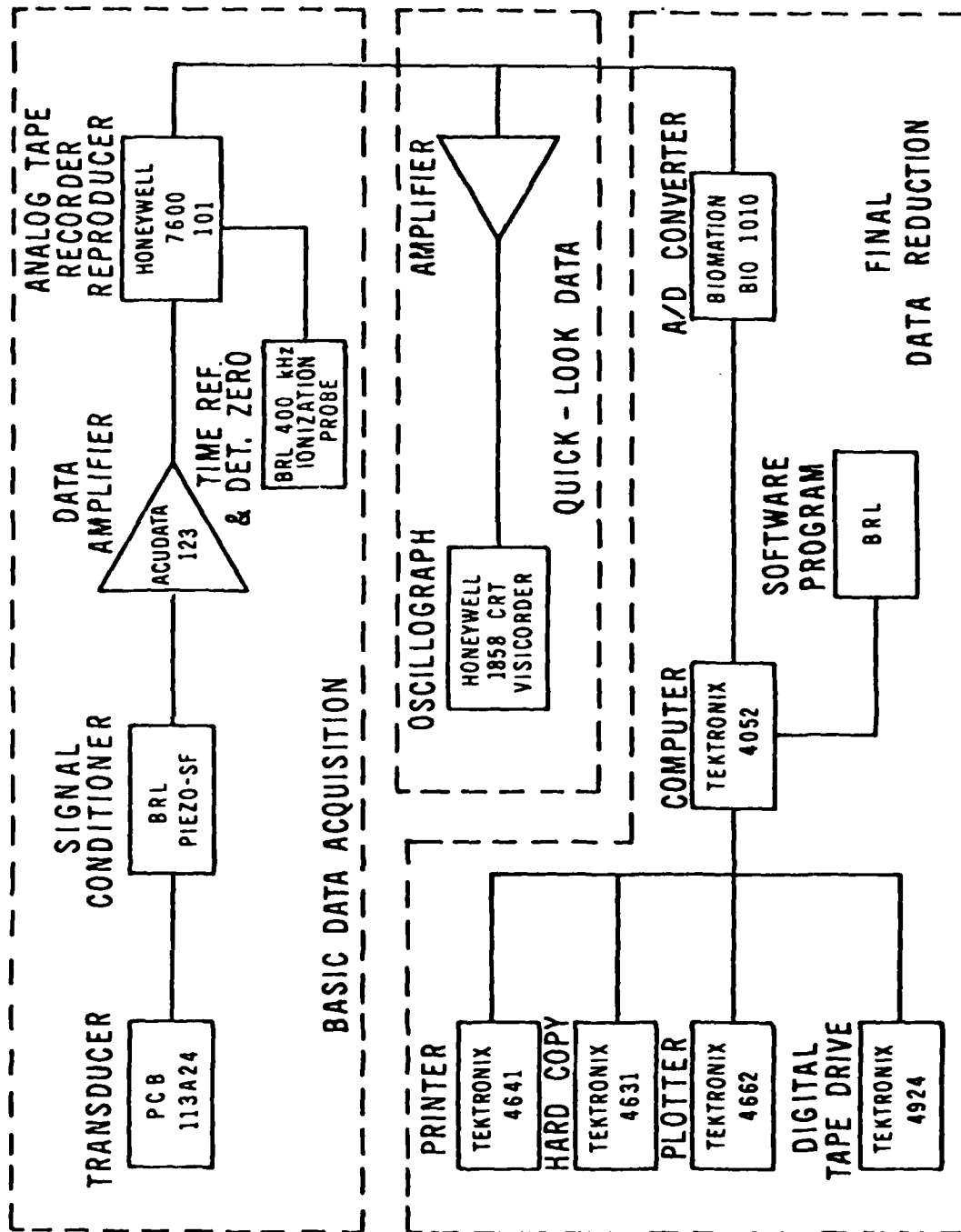

Figure 7. Data Acquisition/Reduction System

E. Test Matrix

A series of six shots was fired during the test period. For the test conditions at the Range 8 test site on Spesutie Island, see Table 1. A responding concrete acceptor model was used only on Shot 1. The remaining shots were made only with the non-responding instrumented steel acceptor. All Pentolite charges were cast and trimmed to be 1 kg hemispherical to make the test comparisons more exact. No scaling was needed between shots. All barricades were constructed of field soil, hard-packed.

TABLE 1. TEST MATRIX

Shot	Donor Cover kg	50/50 Pentolite Charge Weight kg	Concrete Acceptor	Ambient Pressure kPa	Ambient Temp. °C	Wind Speed km/h	Separation Distance Factor
1	5.72	1.00	Yes	101.5	30.0	12 @ 280°	K2
2	5.71	1.00	No	101.9	28.3	5 @ 190°	K4
3	5.33	1.00	No	102.9	25.0	3 @ 90°	K4
4	5.64	1.00	No	102.2	26.1	5 @ 90°	K6
5	5.50	1.00	No	101.8	30.3	5 @ 80°	K6
6	5.50	1.00	No	100.6	29.4	Calm	K6

English	Metric
Note: $K2 = 2W^{1/3}$ ft	$= 0.8Q^{1/3}$ m
$K4 = 4W^{1/3}$ ft	$= 1.6Q^{1/3}$ m
$K6 = 6W^{1/3}$ ft	$= 2.4Q^{1/3}$ m

for K2 English: $W = 2.204$ lbs, the $K2 = 2(1.30)ft = 2.60$ ft.

for K2 metric: $Q = 1$ kg, the $K2 = .8 (1) m = 0.8$ m

III. RESULTS

The results will be presented in photographs of site damage, in data tables, and in pressure-time records taken at various site locations and on the nonresponding model magazine.

A. Site Damage

Figures 8 - 10 illustrate the kind of damage that occurred to the responding model magazine. The donor magazine containing the 1 kg charge was destroyed completely. A crater was formed during each shot measuring 1.2 - 1.4 m across (measured to inside edge) and a depth of 0.26 to 0.28 m at the center. All craters were very similar from shot to shot.

The part of the barricade directly behind the donor charge model magazine was blown through on each shot. Both arms of the barricade on either side of the donor were crushed and moved away from the donor site (crater). The barricade behind and along the far side of the non-responding model was least disturbed of any part of the barricade. See Figures 9 and 10.

Figure 8-B illustrates the crushing and movement of the responding concrete model. Figure 8-C is a photograph of the reconstructed acceptor model showing the break-up of the various model components. The scored near side-wall did break as was anticipated, although the styrofoam witness plate (Figure 3-B) had almost no indentation from the movement of the wall segments. (The next series of tests planned will use velocity screens instead of the witness plate.)

B. Blast Loading on Acceptor Structure Near Side-Wall

Table 2 lists pertinent parameters at the three ground baffle stations. Station 19 is directly in front of the donor magazine. Station 20 is in front of the nonresponding acceptor model magazine, and Station 21 is on the other side of the barricade arm, past the nonresponding model. See Figures 4 - 6 above for the ground station locations for each of the three separation distances.

The peak pressures ranged from about 1500 kPa to 2300 kPa at Station 19 (where the distance remained the same) from 86 - 279 kPa at Station 20, and from 41 - 162 kPa at Station 21 over the three separation distances. For examples, see Figure 11.

Table 3 lists the parameters for the blast loading on the side-wall of the nonresponding model, nearest to the model donor magazine. Maximum values of reflected pressure peaks at Station 3 of about 900, 600, and 360 kPa were measured for separation distances of $0.8 Q^{1/3}$ m, $1.6 Q^{1/3}$ m, and $2.4 Q^{1/3}$ m, respectively. Typical pressure-time waveforms are shown in Figures 12 and 13 for two representative stations, Stations 1 and 3. The

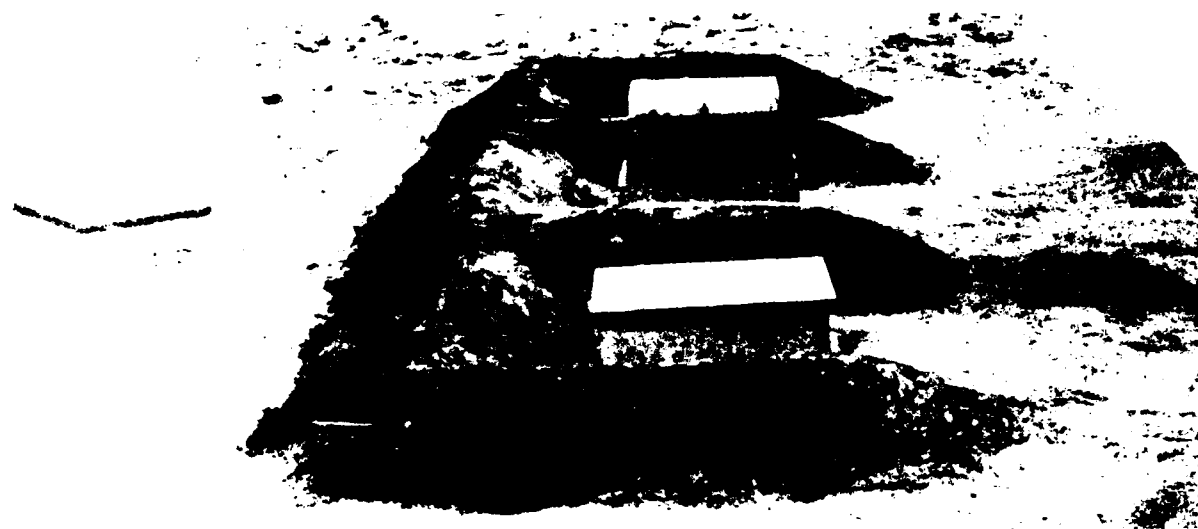

A. Preshot Site



B. Postshot Site

Fig. 7. Photographs for a Separation Distance of $1.8 Q^{1/3}$ m (K2)

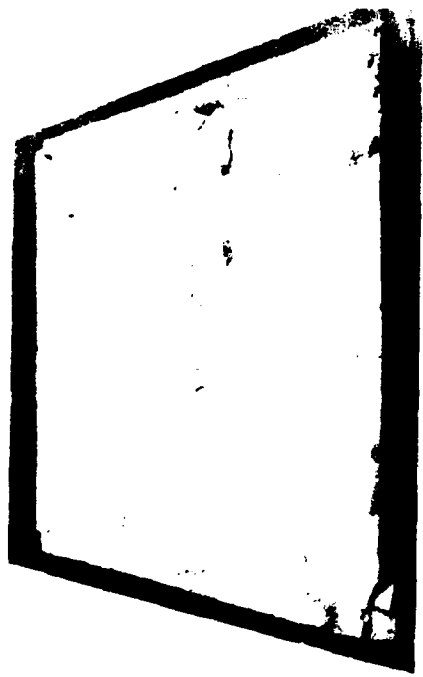

Roof

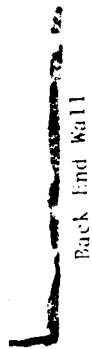

Back End Wall



Floor

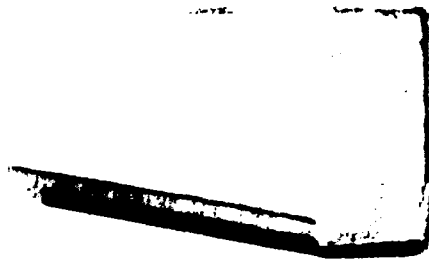

Far Wall



Near Wall

C. Postshot Acceptor Model Magazine

Figure 8. Photographs for a Separation Distance of $0.8 \text{ } \frac{1}{3} \text{ m}$ (K2) (Cont.)

A. Preshot Site



B. Postshot Site

Figure 9. Photographs for a Separation Distance of $1.6 Q^{1/3}$ m (K4)

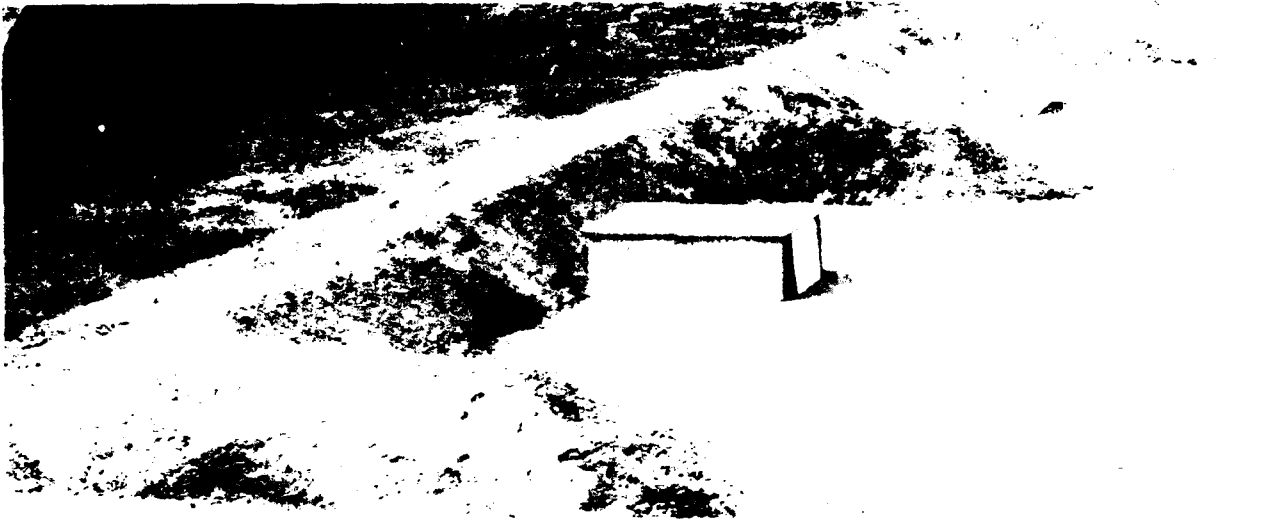

A. Preshot Site



B. Postshot Site

Figure 10. Photographs for a Separation Distance of
 $2.4 \times 10^{1/3}$ m (K6) 25

TABLE 2.. FREE-FIELD BLAST PARAMETERS-WITH BARRICADES

Shot	Station	Distance m	Peak Overpressure kPa	Impulse kPa-ms	Arrival Time ms	Duration ms	Remarks
1	19	1.006	1537	207	0.48	1.16	0.8Q ^{1/3} m
	20	1.523	279	97	1.34	1.41	
	21	2.286	162	88	3.24	1.66	
2	19	1.006	501/1575	238	0.46	1.04	1.6Q ^{1/3} m
	20	2.195	125	86	2.43	2.21	
	21	3.902	76	61	6.74	2.83	
3	19	1.006	2280	312	0.45	0.64	1.6Q ^{1/3} m
	20	2.195	143	89	2.43	2.00	
	21	3.902	67	60	6.77	2.82	
4	19	1.006	2147	229	0.45	0.50	2.4Q ^{1/3} m
	20	2.427	93	78	4.16	2.35	
	21	5.519	28.7	40	10.51	3.10	
5	19	1.006	667/1582	252	0.44	0.71	2.4Q ^{1/3} m
	20	2.427	95	81	4.15	2.43	
	21	5.519	43	48	10.49	3.56	
6	19	1.006	2032	226	0.44	0.67	2.4Q ^{1/3} m
	20	2.427	86	75	4.03	2.40	
	21	5.519	41	46	10.64	3.26	

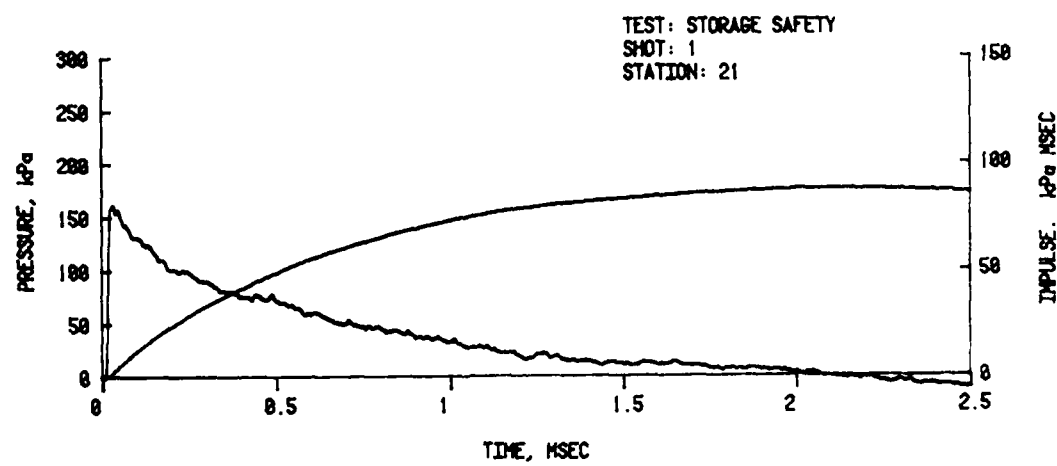
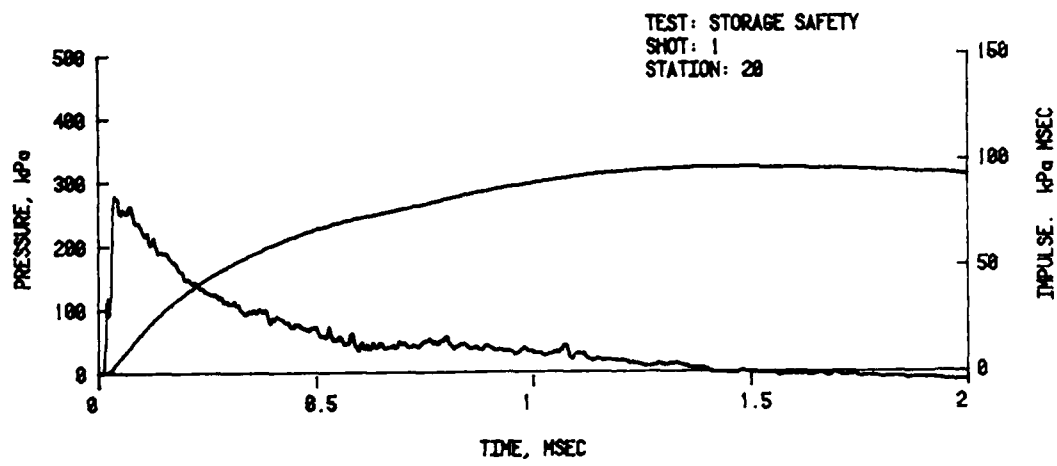
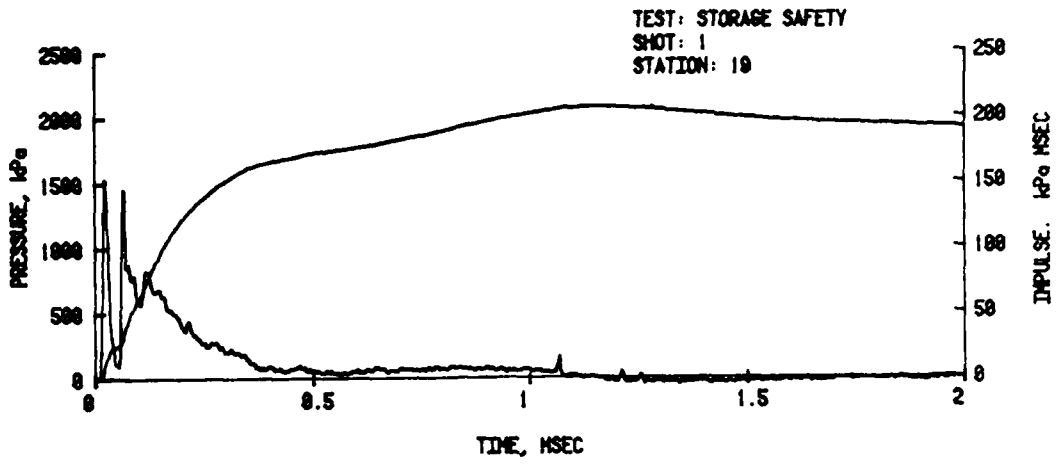

A. $0.8 Q^{1/3}_m$

Figure 11. Pressure-Time Records, Free-Field with Barricades

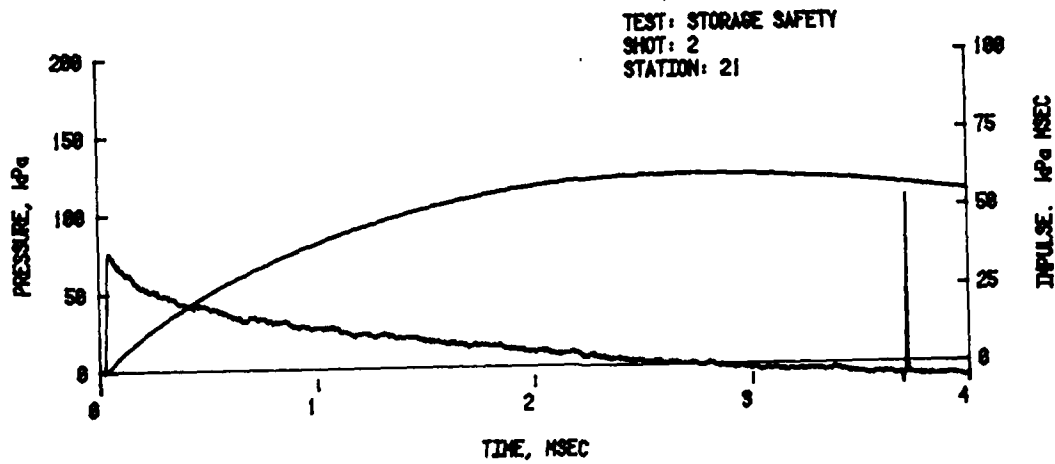
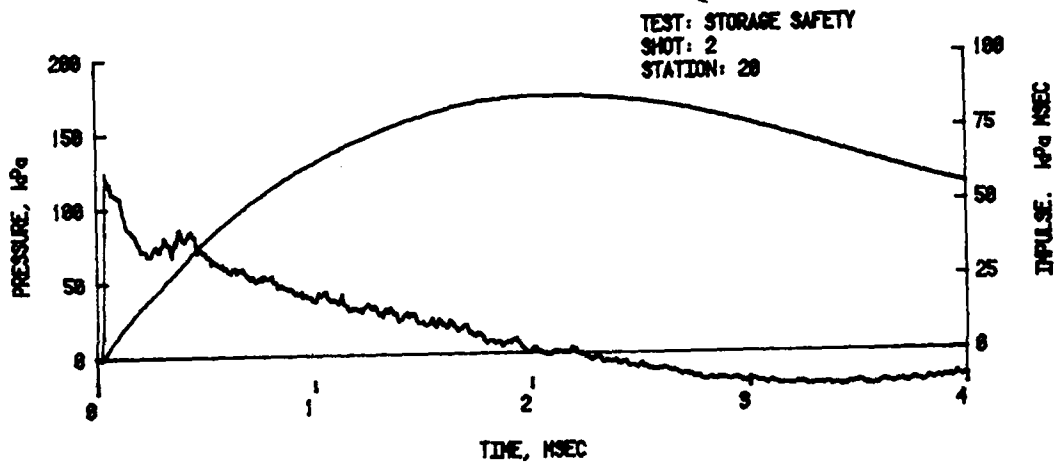
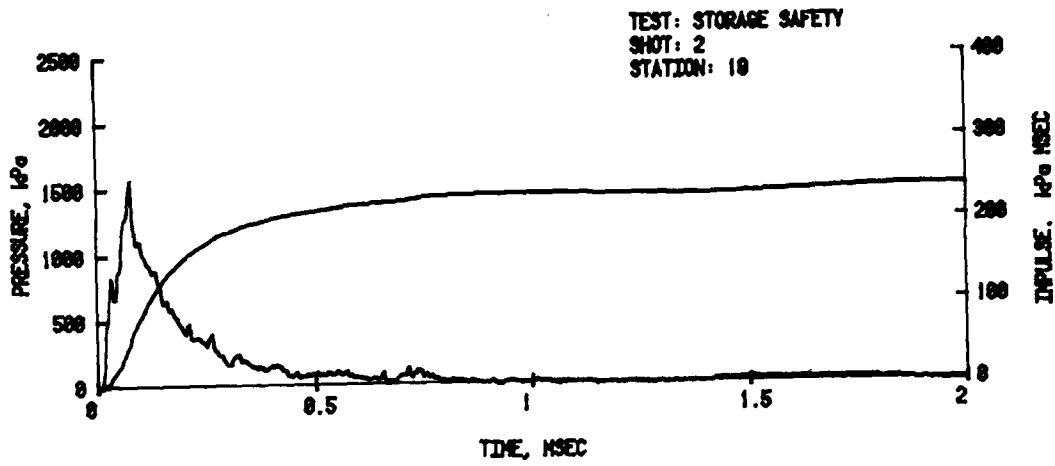

B. $1.6 Q^{1/3}_m$

Figure 11. Pressure-Time Records, Free-Field with Barricades (Cont.)

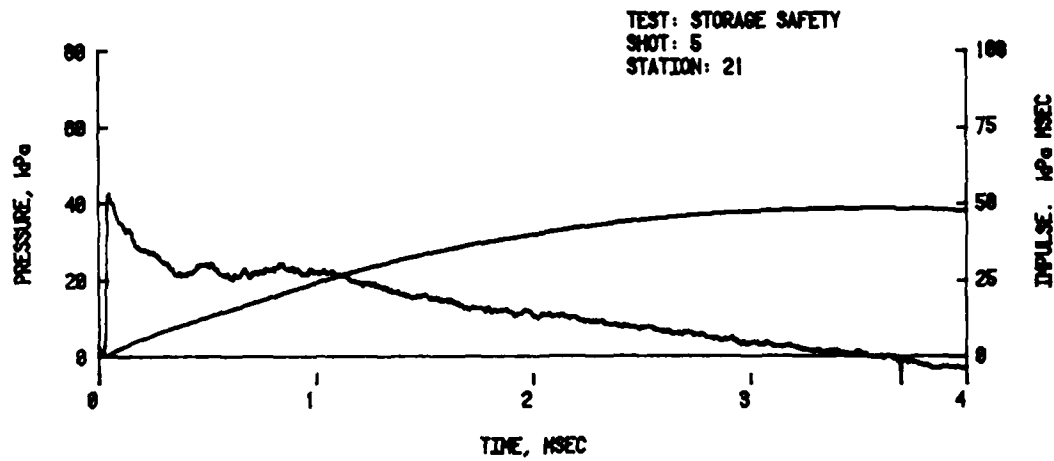
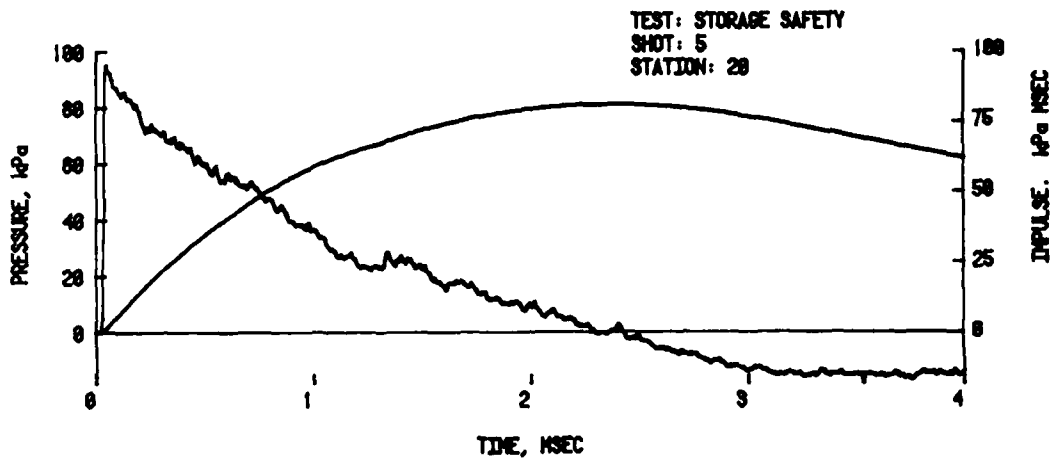
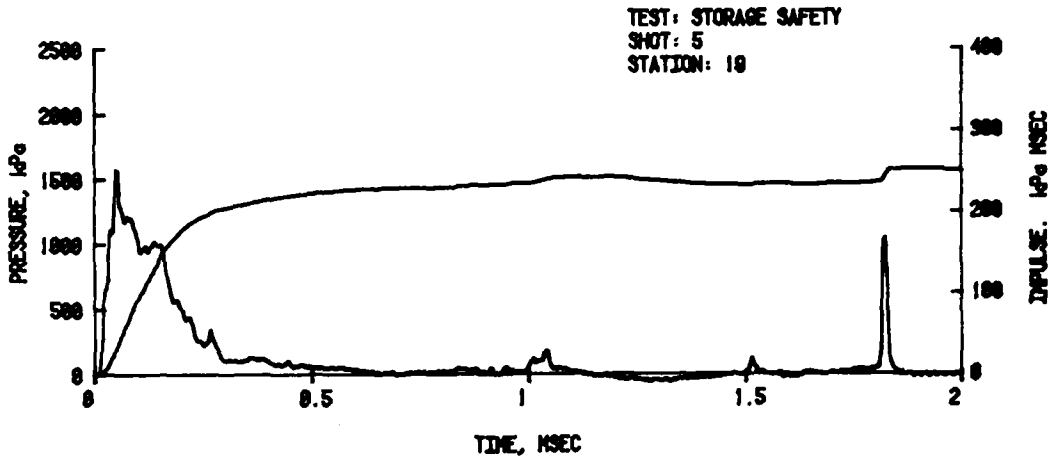

$$C. 2.4 Q^{1/3} m$$

Figure 11. Pressure-Time Records, Free-Field with Barricades (Cont.)

TABLE 3. BLAST LOADING ON NEAR SIDE-WALL

Shot	Station	Peak Pressure kPa	Positive Impulse kPa-ms	Arrival Time ms	Positive Duration ms	Remarks
1	1	1128	182	0.80	0.56	$0.8Q^{1/3}$ m
	2	814/1707*	253	0.85	0.56	
	3	890	205	0.82	0.61	
	4	894	187	0.83	0.69	
	5	815	239	0.84	0.59	
	6	-	-	-	-	
2	1	300/565	165	1.96	1.13	$1.6Q^{1/3}$ m
	2	797/812	209	2.00	0.97	
	3	284/578	197	1.98	0.92	
	4	354/459	195	1.95	0.94	
	5	658	206	1.99	0.81	
	6	339/580	213	1.97	1.02	
3	1	339/513	156	1.88	1.17	$1.6Q^{1/3}$ m
	2	726	194	1.93	1.04	
	3	-	-	-	-	
	4	357/373	180	1.87	1.00	
	5	321/578	210	1.93	0.88	
	6	358/554	198	1.91	1.01	
4	1	488	125	3.40	1.89	$2.4Q^{1/3}$ m
	2	399/420	142	3.41	1.86	
	3	343/349	137	3.40	1.97	
	4	366	138	3.38	2.00	
	5	414/428	164	3.41	1.79	
	6	440	144	3.39	2.00	
5	1	319/416	119	3.49	1.58	$2.4Q^{1/3}$ m
	2	299/356	133	3.49	1.11	
	3	304/369	133	3.49	1.26	
	4	472	142	3.48	2.00	
	5	288/391	144	3.49	0.98	
	6	306/420	145	3.49	2.00	
6	1	243	106	3.40	1.96	$2.4Q^{1/3}$ m
	2	246	116	3.40	1.78	
	3	240	112	3.40	1.72	
	4	264	119	3.40	1.82	
	5	256/263	124	3.41	1.66	
	6	270	123	3.41	1.64	

*Second value refers to maximum reflected pressure peak if the initial peak is not the maximum.

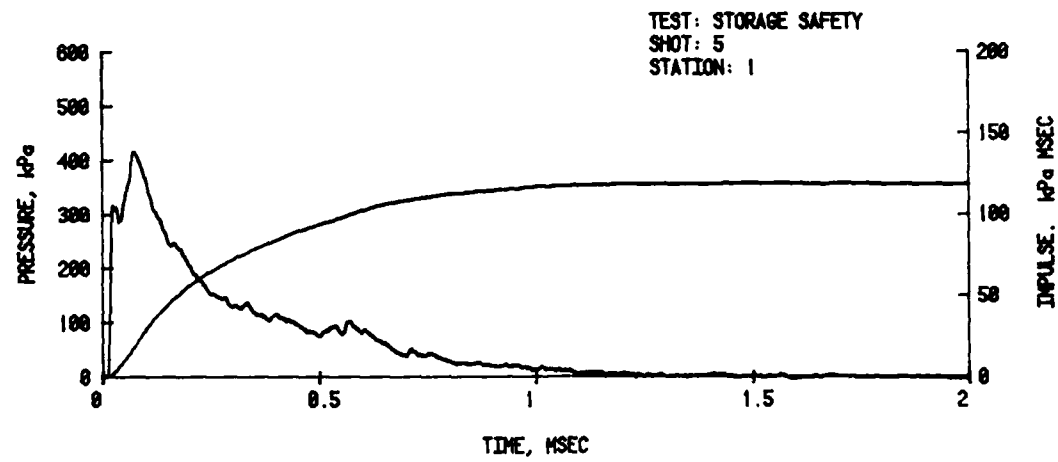
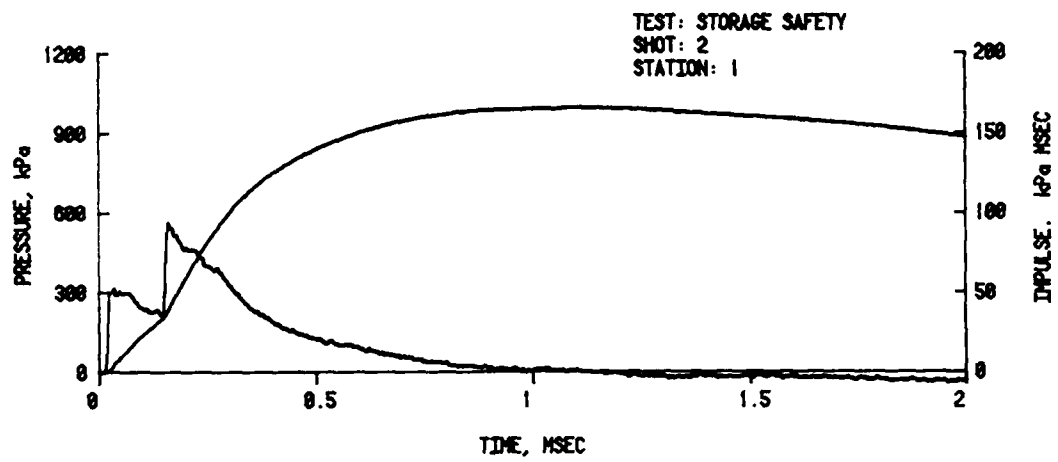
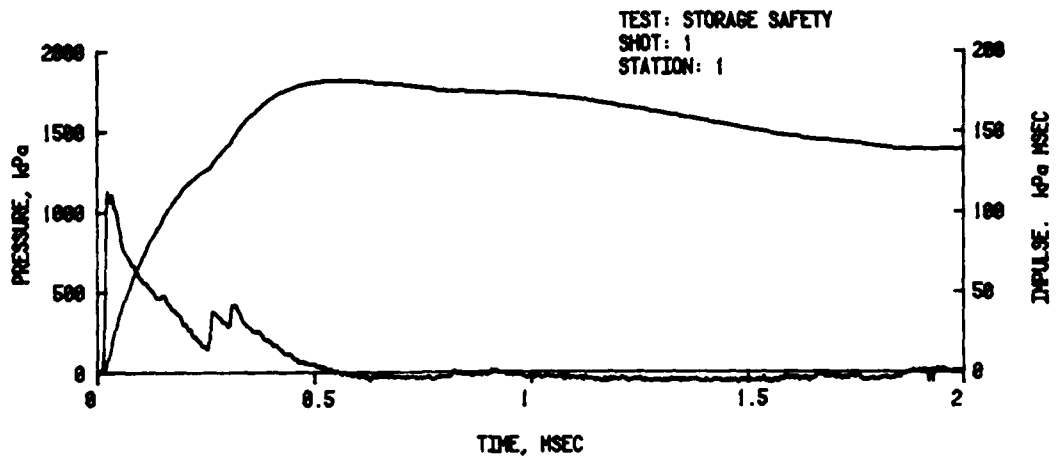

Figure 12. Pressure-Time Records from Near Side-Wall,
Station 1

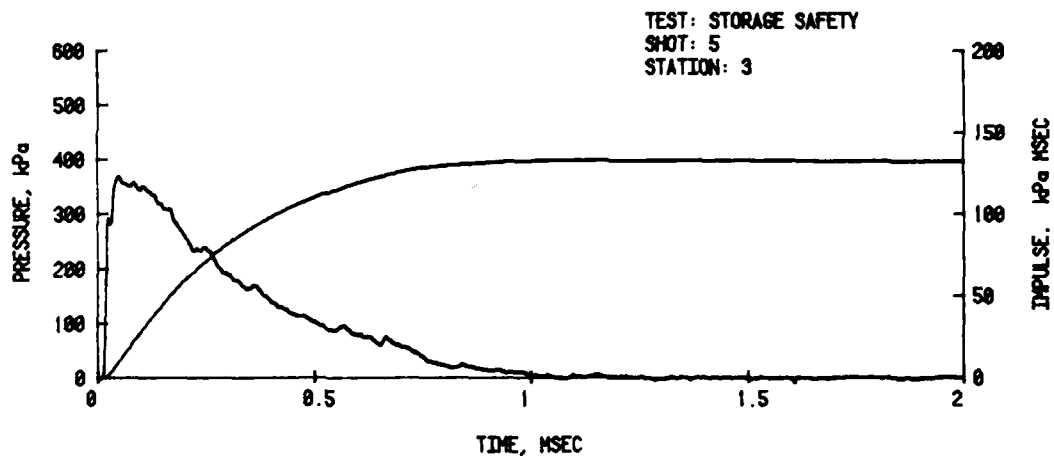
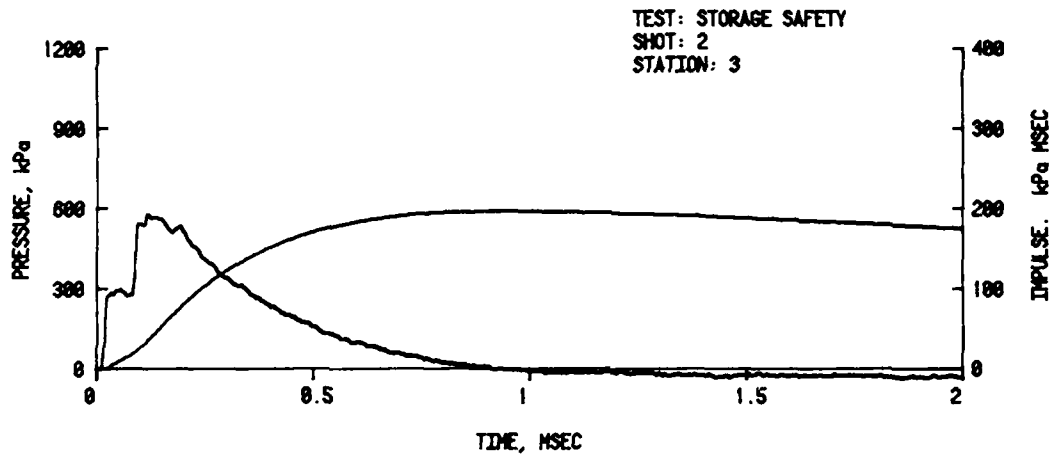
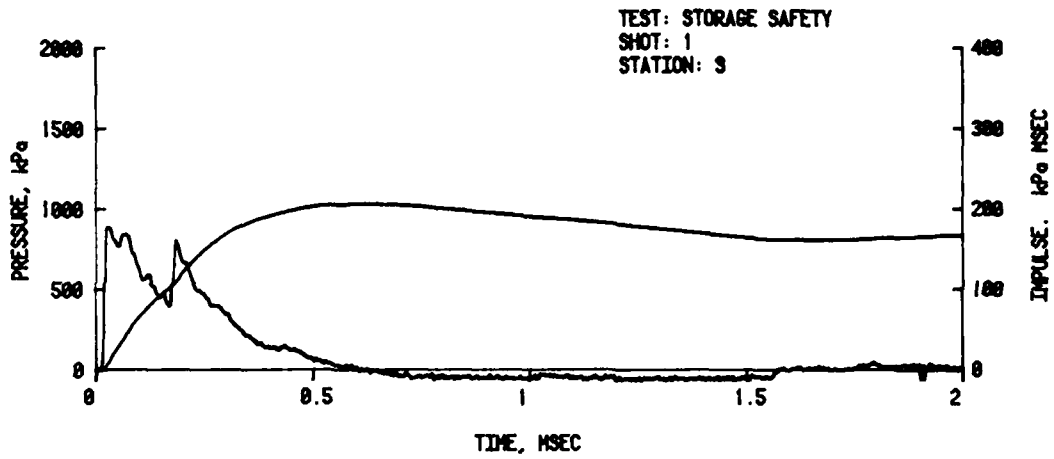

Figure 13. Pressure-Time Records from Near Side-Wall,
Station 3

waveform change as a function of separation distance is shown by the variation in peak formation: a large initial peak, a small initial peak and finally almost a single peak again. It should be pointed out that the difference in wave shapes at Stations 1 and 3 as shown in Figures 12 and 13 is because of the Mach reflection process where the reflection wave is catching up to the incidence shock as the distance from ground zero increases.

C. Blast Loading on Acceptor Structure - Roof

Table 4 lists the blast loading parameters for the roof of the acceptor model. Maximum values of about 480, 170, and 180 kPa were recorded at Station 13 for the three separation distances. Figures 14 - 16 are examples of the pressure-time curves recorded from Stations 13, 14, and 16. The waveforms are quite similar (for a specific shot) with some decay of peak pressure during the crossing of the roof.

D. Blast Loading on Acceptor Structure - Ends

Maximum peak pressure is seen to occur (Table 5) at Station 11 with a variation of about 500, 195, and 120 kPa corresponding to the three separation distances. The waveforms are shown in Figures 17 and 18. The general shape of the records from both ends of the acceptor magazine are quite similar, as were those on the roof.

E. Blast Loading on Acceptor Structure - Far Side-Wall

Table 6 lists the maximum peak pressure as measured on the far side-wall of the acceptor magazine. The values ranged from about 200 kPa for Station 9 at a distance of $0.8 Q^{1/3}$ m to a low of about 62 kPa at a distance of $2.4 Q^{1/3}$ m.

Figures 19 and 20 illustrate the variety of waveforms to be found on the far side-wall. A great many small reflections were recorded at the outer edge at Station 8 during Shot 1. At Station 9, near the center of the wall, large distinct reflections from the ground surface and the barricade were recorded for all three separation distances. No record approached the maximum pressure level measured on the near side-wall, however.

TABLE 4. BLAST LOADING ON ROOF

Shot	Station	Peak Pressure kPa	Positive Impulse kPa-ms	Arrival Time ms	Positive Duration ms	Remarks
1	12	418	99	0.84	0.86	$0.8Q^{1/3}$ m
	13	481	120	0.84	0.92	
	14	397	108	0.99	1.07	
	15	273	91	1.18	1.55	
	16	350	105	1.16	1.32	
2	12	143/147	62	2.03	0.70	$1.Q^{1/3}$ m
	13	146/149	63	2.03	0.70	
	14	152	91	2.25	1.32	
	15	125/141	78	2.51	1.86	
	16	140	80	2.49	1.92	
3	12	158	70	1.95	1.63	$1.6Q^{1/3}$ m
	13	169	74	1.97	0.80	
	14	148/160	84	2.18	1.41	
	15	125	75	2.43	2.00	
	16	128	72	2.41	1.96	
4	12	161	52	3.51	1.60	$2.4Q^{1/3}$ m
	13	39/156	50	3.45	0.90	
	14	35/146	71	3.64	2.52	
	15	126	70	3.94	2.76	
	16	135	73	3.84		
5	12	162	56	3.59	1.98	$2.4Q^{1/3}$ m
	13	179	58	3.58	0.91	
	14	149	73	3.79	2.59	
	15	136	66	4.04	2.59	
	16	166	68	4.02	2.61	
6	12	92/101	65	3.51	1.91	$2.4Q^{1/3}$ m
	13	103	54	3.52	1.24	
	14	93	71	3.76	2.51	
	15	77	64	4.04	2.58	
	16	88	67	4.02	2.51	

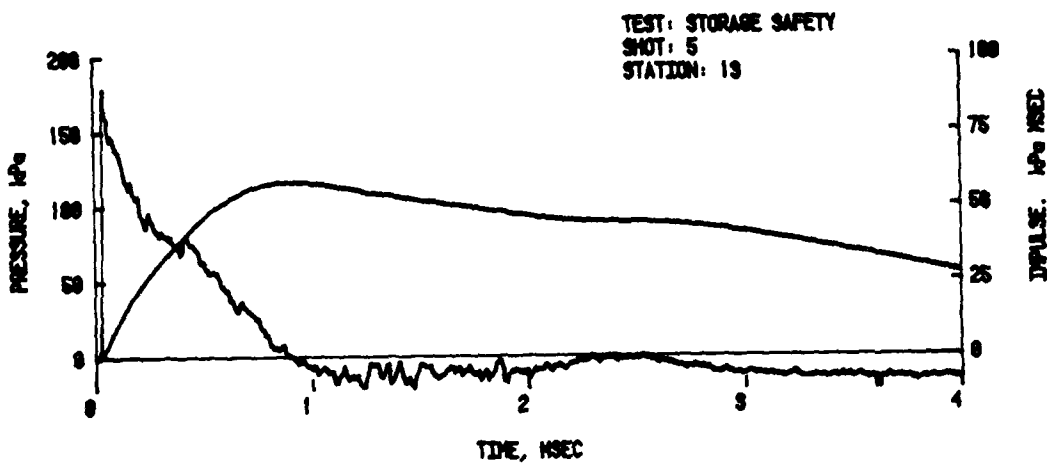
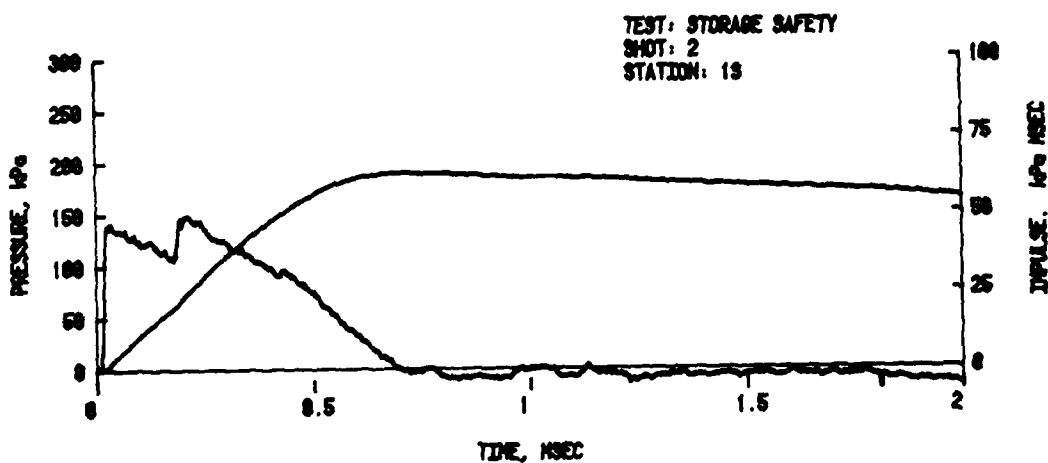
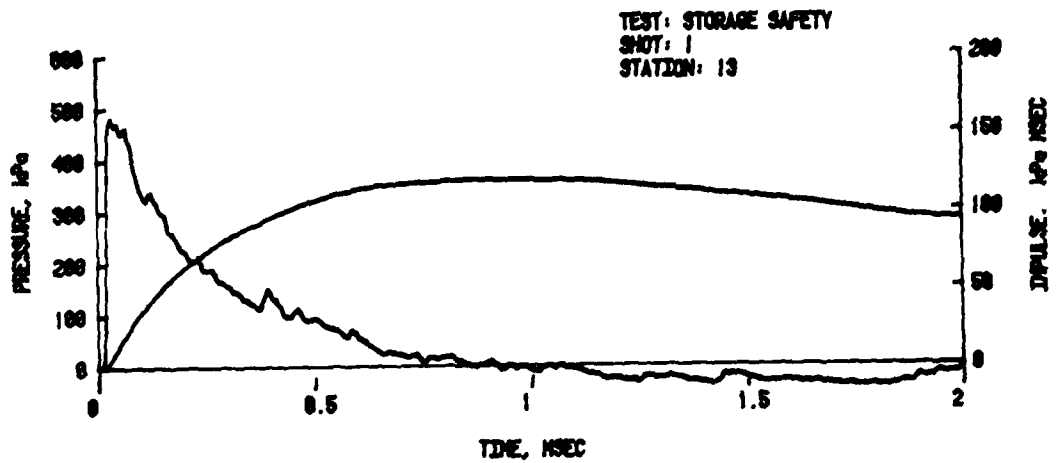

Figure 14. Pressure-Time Records from the Roof,
Station 13

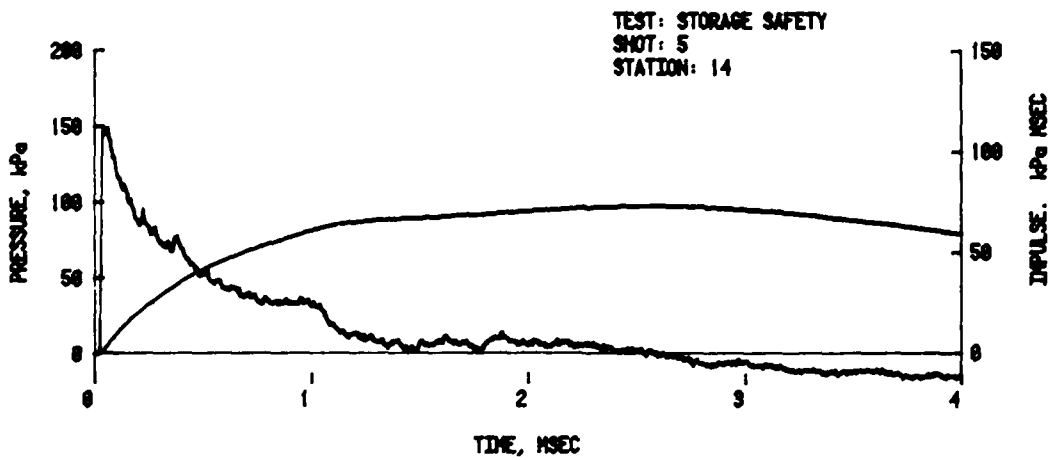
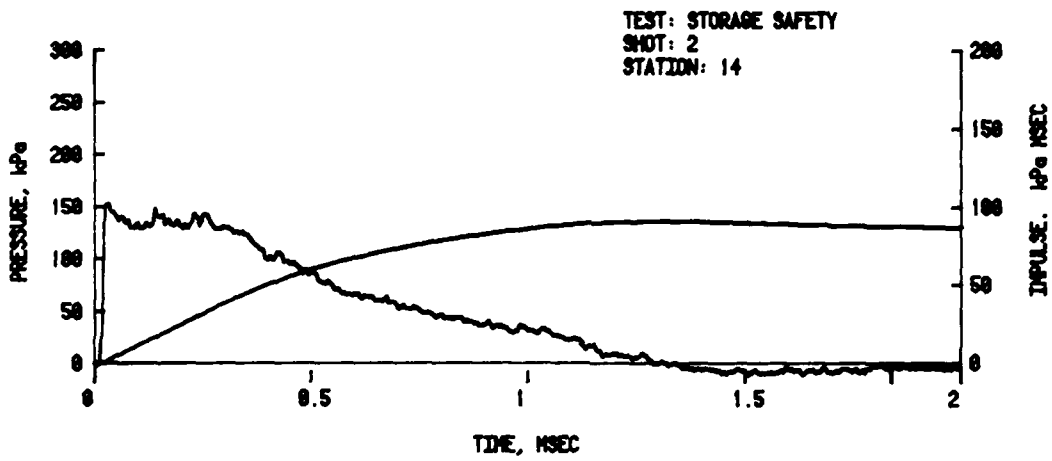
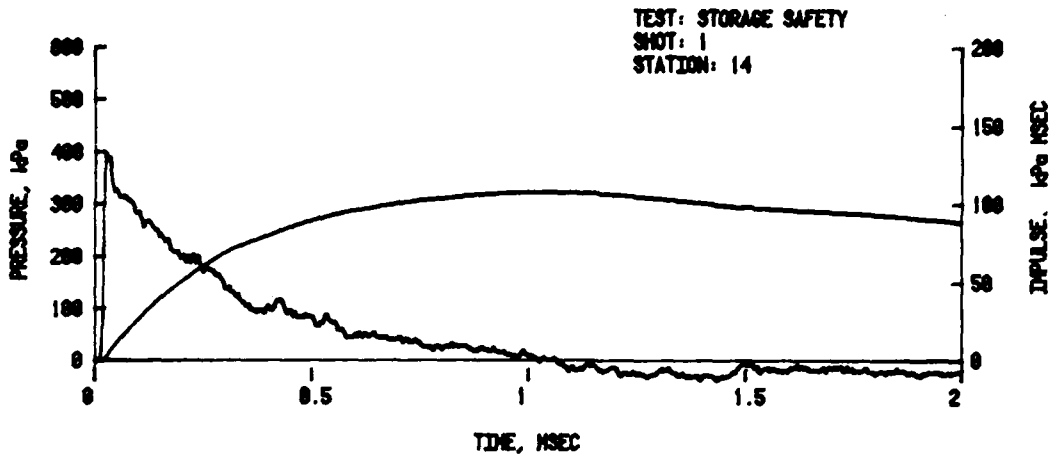

Figure 15. Pressure-Time Records from the Roof,
Station 14

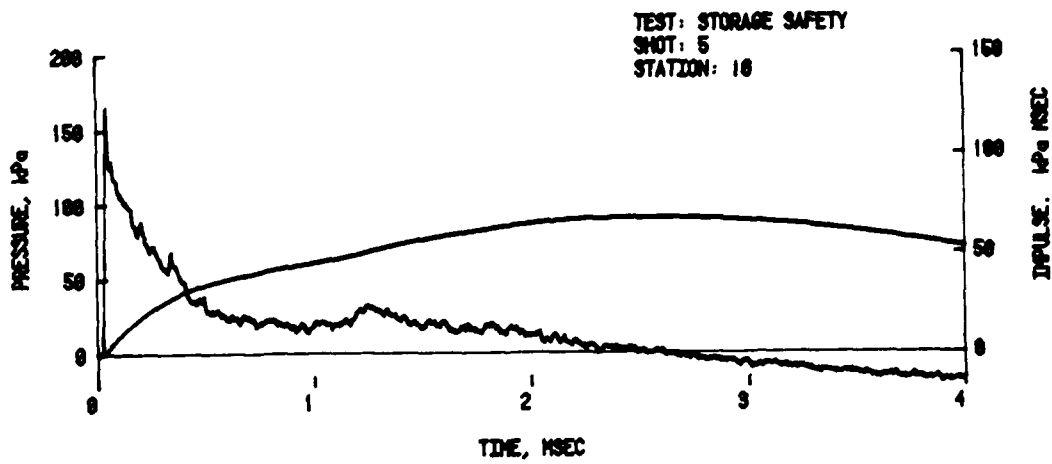
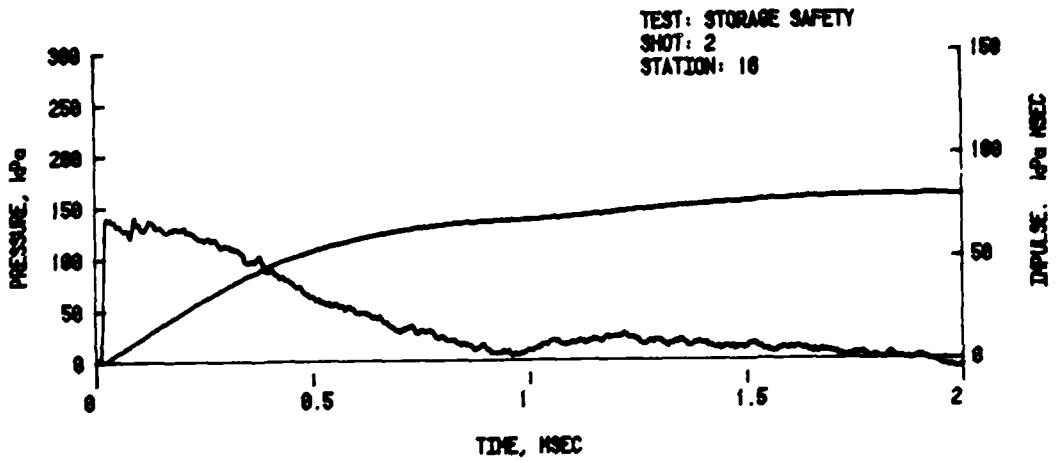
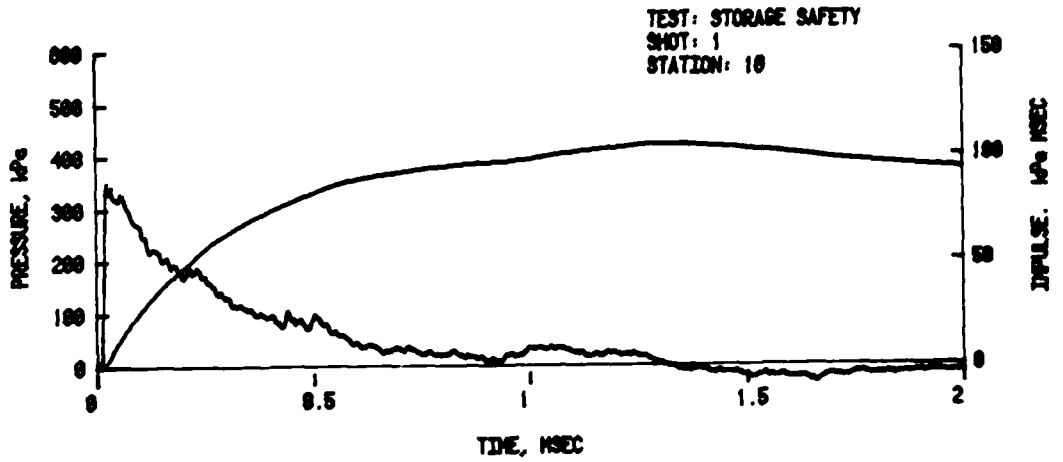

Figure 16. Pressure-Time Records from the Roof,
Station 16

Table 5. BLAST LOADING ON END WALLS

Shot	Station	Peak Pressure kPa	Positive Impulse kPa-ms	Arrival Time ms	Positive Duration ms	Remarks
1	10	240/478	104	1.06	0.99	0.8Q ^{1/3} m
	11	518	114	1.10	0.83	
	17	242/297	105	1.08	1.27	
	18	332	108	1.10	1.22	
2	10	189	88	2.29	1.37	1.6Q ^{1/3} m
	11	172/184	94	2.32	1.41	
	17	170	96	2.30	1.48	
	18	145/167	91	2.29	1.44	
3	10	188	81	2.22	1.33	1.6Q ^{1/3} m
	11	195	83	2.24	1.26	
	17	186	94	2.26	1.47	
	18	167	91	2.25	1.41	
4	10	117	70	3.76	2.36	2.4Q ^{1/3} m
	11	129	94	3.82	4.00	
	17	116	74	3.81	2.46	
	18	117	81	3.82	2.61	
5	10	127	72	3.85	2.85	2.4Q ^{1/3} m
	11	96/120	67	3.88	1.83	
	17	133	78	3.87	2.27	
	18	95/115	81	3.86	2.42	
6	10	84	64	3.77	2.48	2.4Q ^{1/3} m
	11	81	75	3.79	2.72	
	17	93	71	3.80	2.02	
	18	90	71	3.79	2.42	

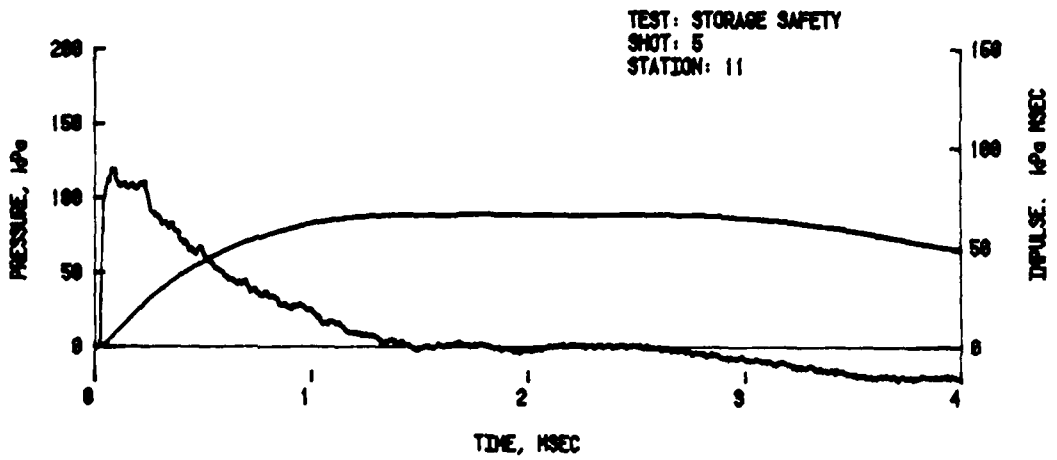
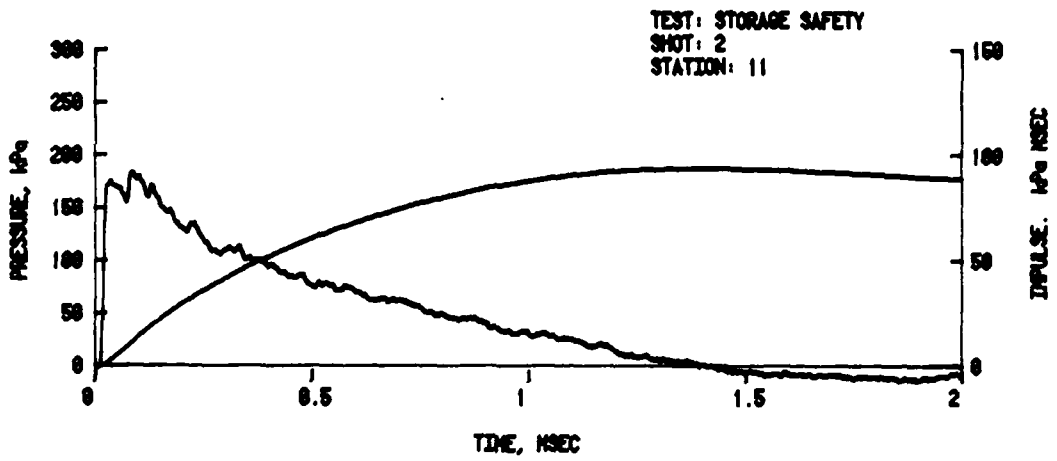
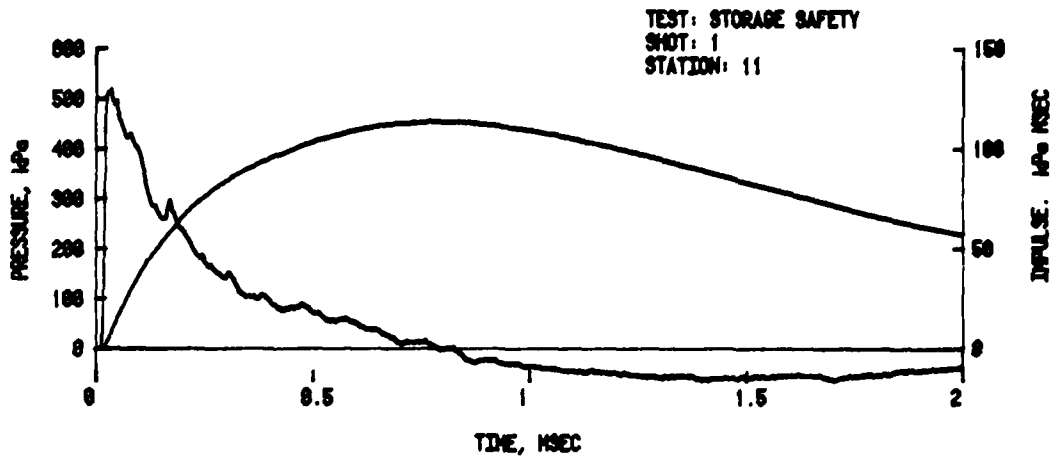

Figure 17. Pressure-Time Records from Back End-Wall,
Station 11

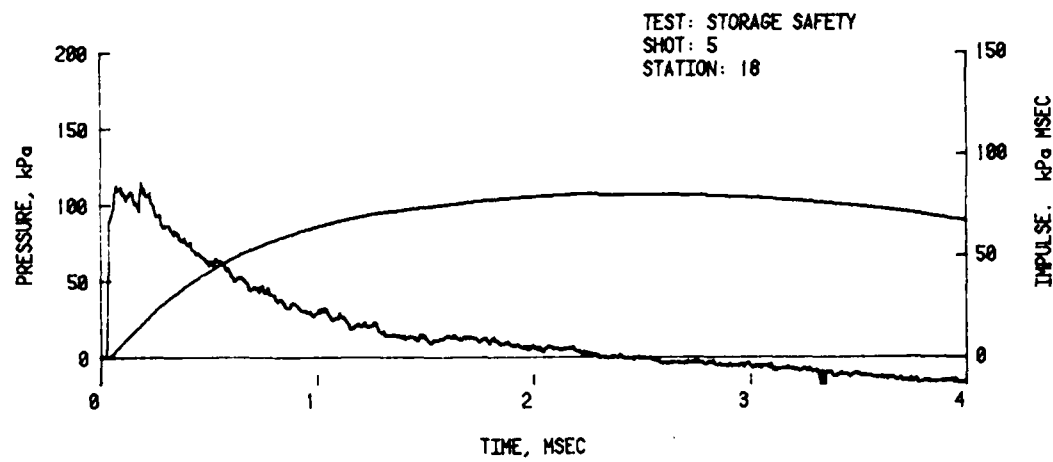
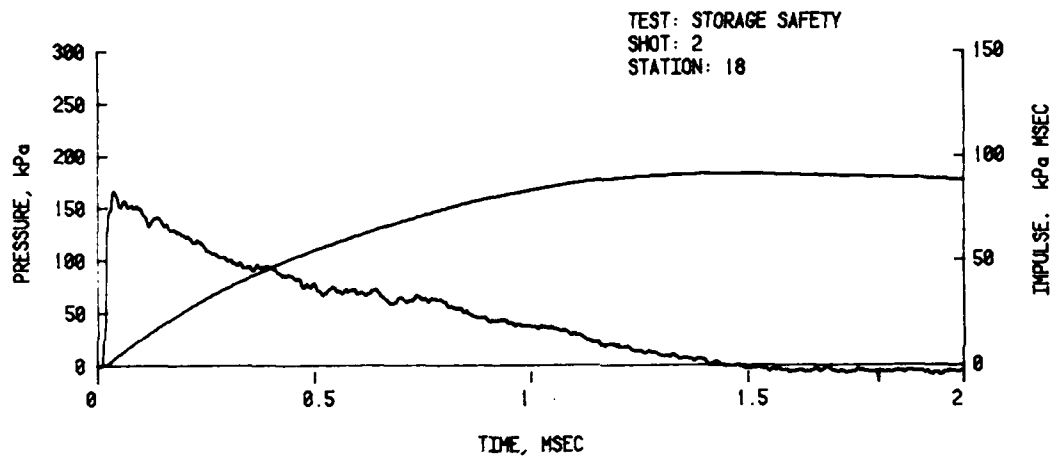
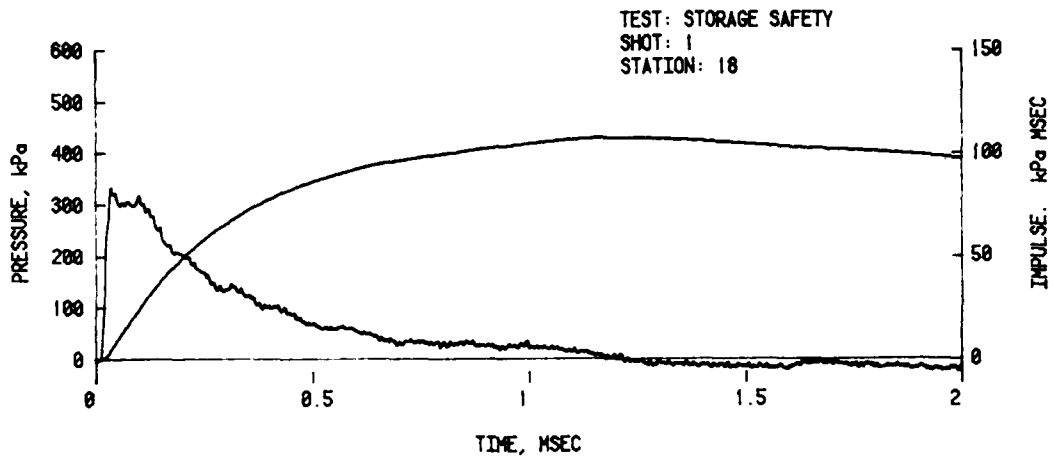

Figure 18. Pressure-Time Records from Front End Wall,
Station 18

Table 6. BLAST LOADING ON FAR SIDE-WALL

Shot	Station	Peak Pressure kPa	Positive Impulse kPa-ms	Arrival Time ms	Positive Duration ms	Remarks
1	7	63/81	70	1.33	1.85	0.8Q ^{1/3} m
	8	83/141	117	1.47	1.75	
	9	65/198	114	1.42	1.70	
2	7	27/64	30	2.70	1.68	1.6Q ^{1/3} m
	8	34/73	67	2.79	3.16	
	9	44/80	80	2.79	3.07	
3	7	34/61	32	2.62	1.71	1.6Q ^{1/3} m
	8	34/64	78	2.72	3.18	
	9	39/87	82	2.72	3.18	
4	7	28/42	59	4.09	2.49	2.4Q ^{1/3} m
	8	61	62	4.29	2.58	
	9	28/62	60	4.12	2.65	
5	7	31/43	56	4.23	2.85	2.4Q ^{1/3} m
	8	27/63	66	4.39	2.82	
	9	36/83	68	4.32	2.80	
6	7	18/42	61	4.24	2.89	2.4Q ^{1/3} m
	8	14/46	61	4.34	2.60	
	9	8.6/62	57	4.34	2.47	

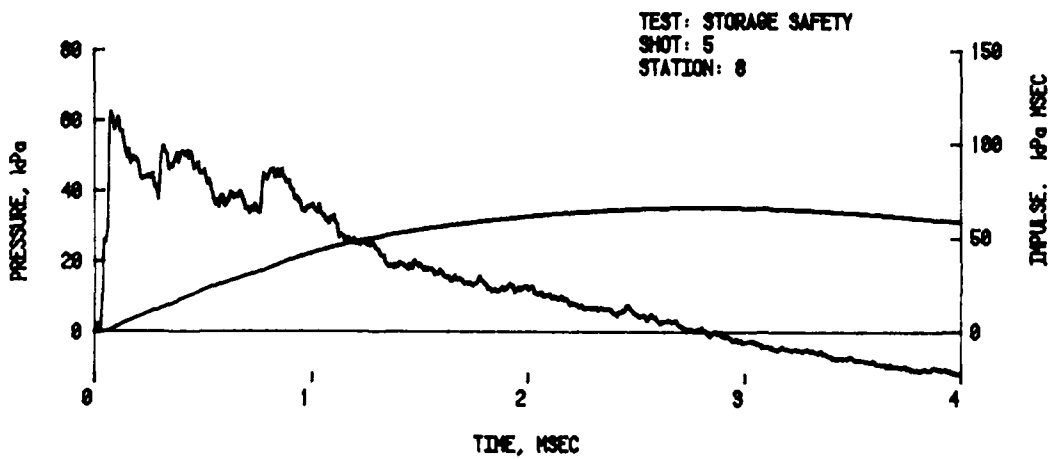
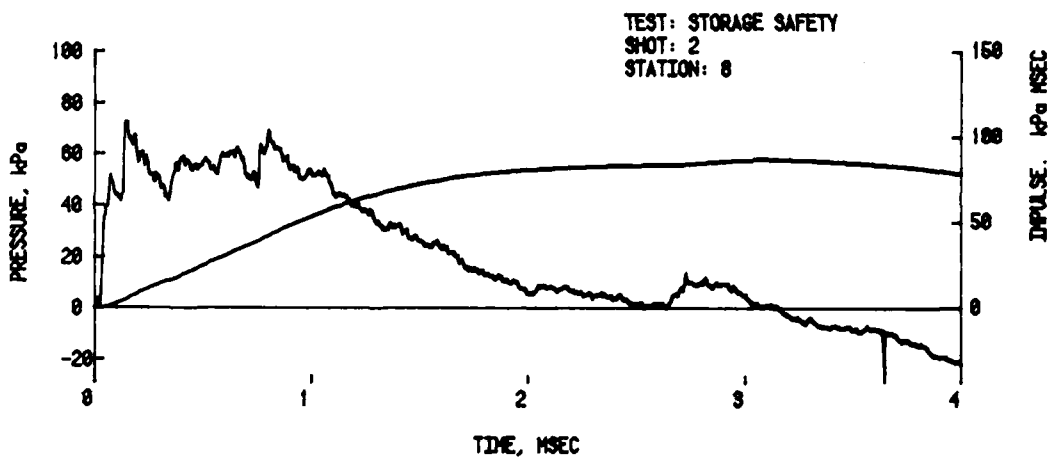
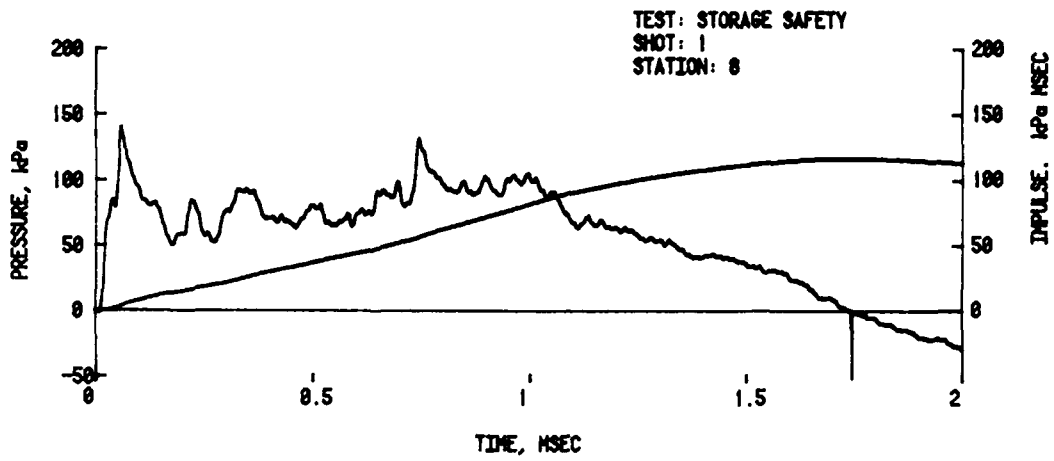

Figure 19. Pressure-Time Records from Far Side-Wall, Station 8

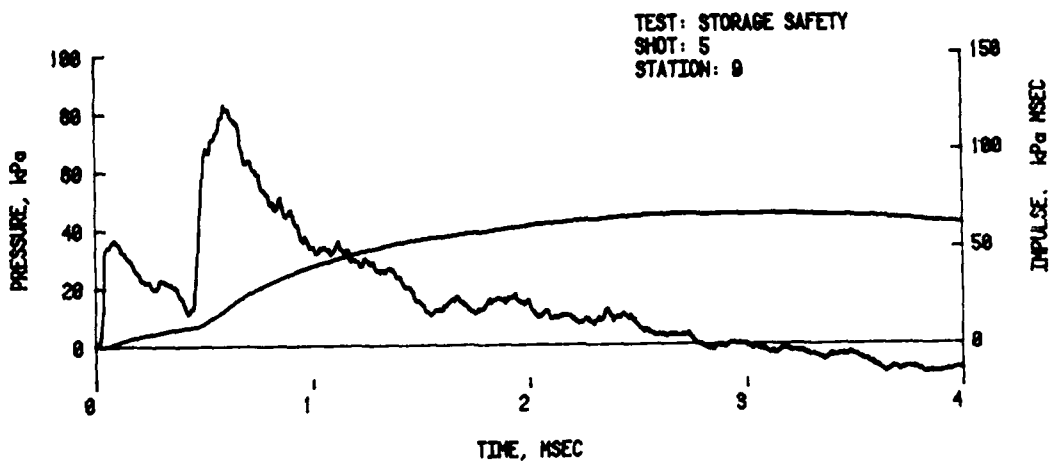
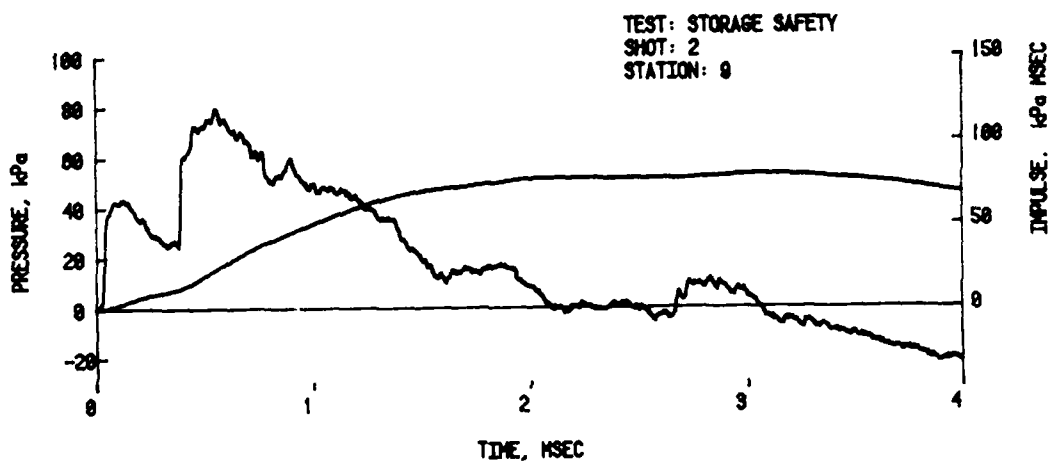
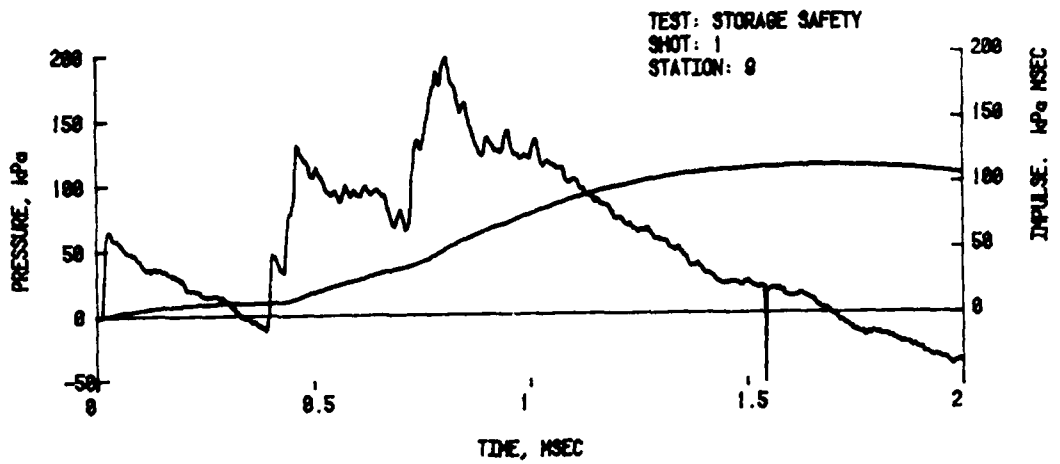

Figure 20. Pressure-Time Records from Far Side-Wall,
Station 9

IV. ANALYSIS

A. Blast Suppression Factors

The blast wave from the charge inside the donor magazine is suppressed to the sides and to the rear by both the presence of the cover and also the barricades. The cover effect is similar to that for a cased charge. Reference 1 gives an expression for a case correction factor, f_c , which will be used for the cover effect of the donor structure.

$$f_c = 0.02 + \frac{0.80}{1 + (W_{CT}/W_{NEW})}, \quad (1)$$

where W_{CT} is the total case weight (donor structure cover) and W_{NEW} is the net explosive weight. For an average value of 5.566 kg for W_{CT} and 1 kg for W_{NEW} , f_c is found from Equation 1 to be 0.321 kg.

The equivalent TNT weight, W_{TNT} , for a Pentolite charge and the donor structure is found from Equation 2.

$$W_{TNT} = f_c \times f_e \times W_{NEW}, \quad (2)$$

where the case factor, f_c , is taken as 0.321 and the pressure equivalent explosive weight factor, f_e , for Pentolite is 1.17 from Reference 3. The equivalent base TNT weight, W_{TNT} , is 0.375 kg of TNT, from Equation 2.

Alternate comparisons of the suppressive effects may be made by comparing the measured parameters at Station 20 (in front of the acceptor magazine model) with the free-field values from the standard curves for hemispherical TNT detonated on a hard surface. See References 4 and 5 for the scaling rules. The scaling rule used is given in Equation 3 for the charge mass-distance relationship. At a given peak overpressure

$$Q_2 = Q_1 \left(\frac{R_2}{R_1} \right)^3, \quad (3)$$

where R_1 is the distance from Q_1 (1 kilogram of explosive)

and R_2 is the distance from Q_2 (the equivalent mass of bare TNT needed to give the experimentally suppressed values for a 1 kilogram charge inside the donor magazine model).

The values of R_1 and R_2 are read from Figure 21A for Station 20 and 21B for Station 21. These are listed in Table 7 with the equivalent bare charge mass Q_2 . The average value for Q_2 of 0.43 at Station 20 compares quite well with the value of 0.38 calculated from Equation 2. It can be seen in Figure 21B that the suppressive effect is not evident at Station 21. The average value of Q_2 at Station 21 is 1.02 which implies no suppression of peak overpressure.

As noted in Reference 2 the impulse in the blast wave from the covered donor does not produce the same Q_2 values when standard scaling procedures are used. To determine the Q_2 based on impulse the following procedure was used.

A ratio of experimental values I_2/R_2 from Table 2 are determined for each shot. These are plotted along with the standard impulse/distance (I_1/R_1) versus distance curve in Figure 22. For a ratio of I_1/R_1 equal to I_2/R_2 , an R_1 is found. The values of R_2 and R_1 found in this way may now be put into Equation 3 to calculate Q_2 . These ratios of impulse and distance, and Q_2 values for Stations 20 and 21 are listed in Table 8. It can be seen that the Q_2 values for impulse are quite different from the Q_2 values calculated from the suppression of peak overpressure. The Q_2 values are also different for the two station locations. Table 8 can be summarized by stating that the impulse at Station 20 from a 1 kg covered donor can be matched with a 0.56 bare charge, and at Station 21 would require a 0.72 kg charge.

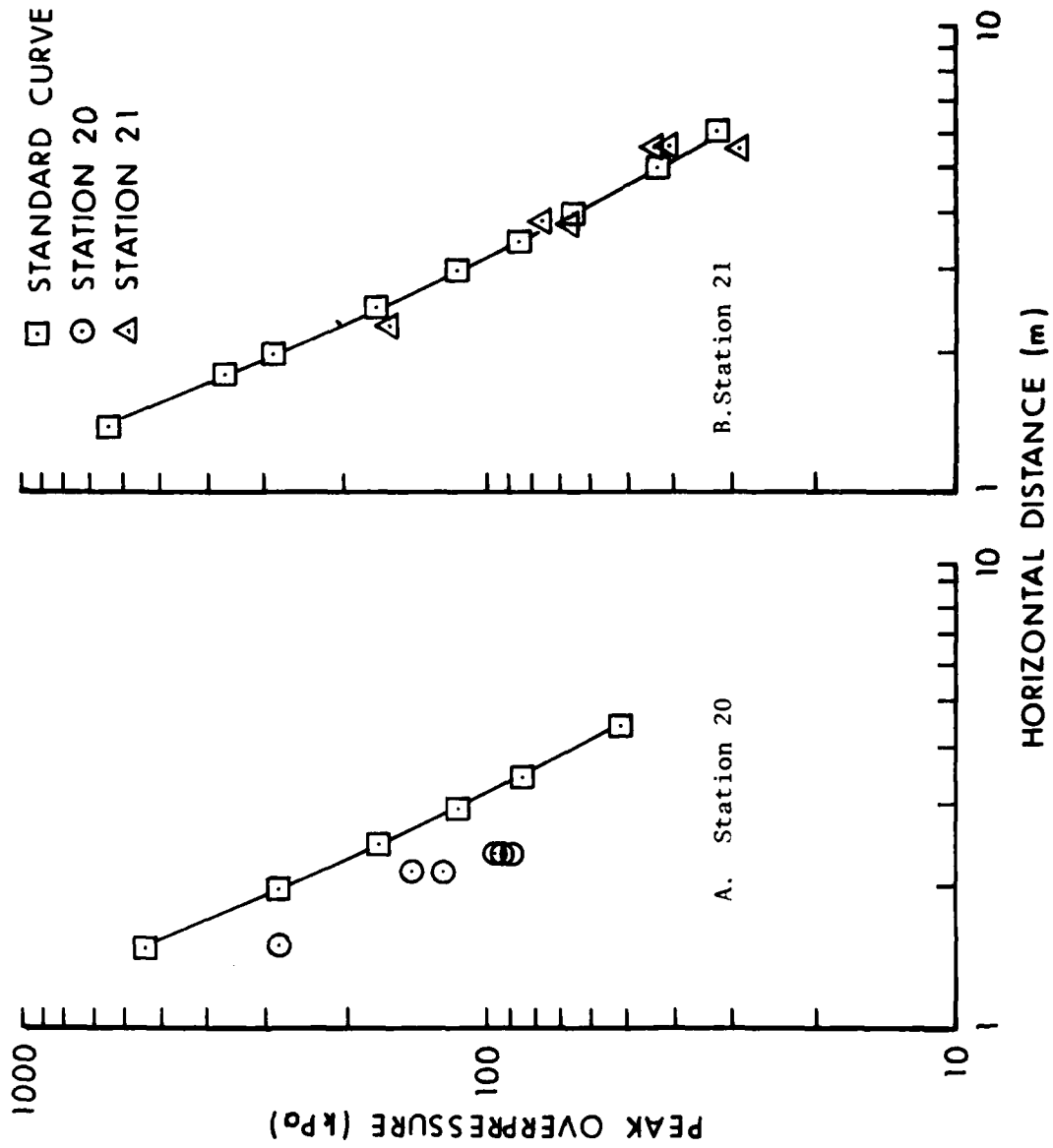

Figure 21. Comparison of Standard Free-Field Pressures to Data from Stations 20 and 21.

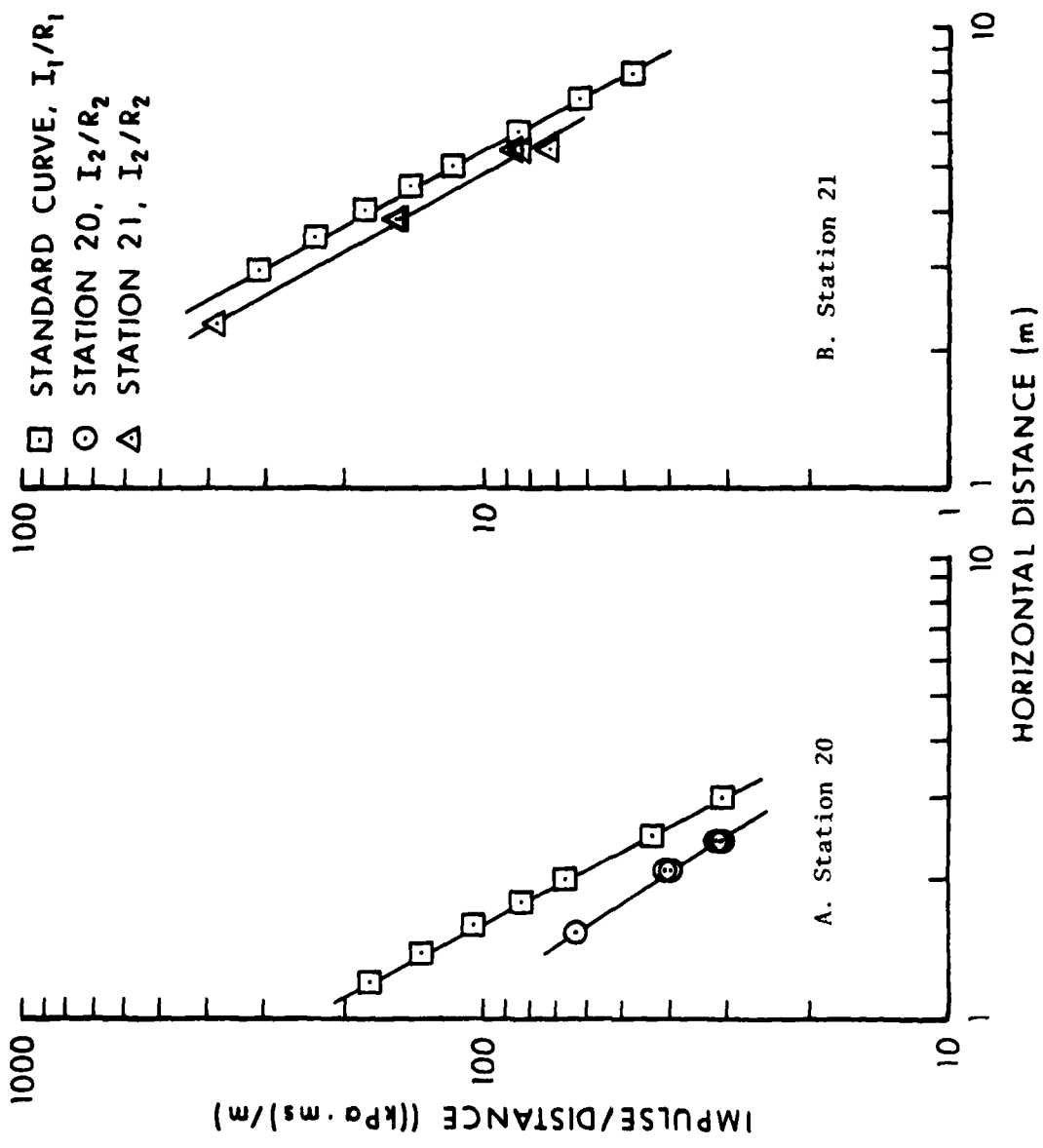

Figure 22. Comparison of Standard Free-Field Impulse to Data from Stations 20 and 21

TABLE 7. SUPPRESSION EFFECTS ON PRESSURE

Shot No.	Distance		Pressure kPa	TNT Equivalence kg
	R ₁ m	R ₂ m		
<u>Station 20. Compared to Free Field Side-On Overpressure, Q₁ = 1 kg.</u>				
1	2.00	1.52	279	0.44
2	2.90	2.20	125	0.44
3	2.70	2.20	143	0.54
4	3.35	2.43	93	0.38
5	3.30	2.43	95	0.40
6	3.45	2.43	86	0.35
			Avg.	0.43
<u>Station 21. Compared to Free Field Side-On Overpressure, Q₁ = 1 kg.</u>				
1	2.55	2.29	162	0.72
2	3.70	3.90	76	1.17
3	3.95	3.90	67	0.96
4	6.35	5.52	29	0.66
5	5.00	5.52	43	1.35
6	5.15	5.52	41	1.23
			Avg.	1.02
<u>Calculated from Equation 2 Above - Analysis Section</u>				
All	--	--	--	0.38

TABLE 8. SUPPRESSION EFFECTS ON IMPULSE

Shot No.	Experiment		Ratio	Standard		Ratio	Ratio	$\frac{Q_2}{(R_2/R_1)^3}$
	I_2 kPa-ms	R_2 m	I_2/R_2 kPa-ms/m	I_1 kPa-ms	R_1 m	I_1/R_1 kPa-ms/m	R_2/R_1	

Station 20 Compared to Free-Field Side-On Impulse

1	97	1.523	63.69	131	2.05	63.69	0.74	0.41
2	86	2.195	39.18	102	2.60	39.18	0.84	0.59
3	89	2.195	40.55	103	2.55	40.55	0.86	0.64
4	78	2.427	32.14	94	2.92	32.14	0.83	0.57
5	81	2.427	33.37	96	2.88	33.37	0.84	0.59
6	75	2.427	30.90	93	3.00	30.90	0.81	0.53
							Avg.	0.56

Station 21 Compared to Free-Field Side-On Impulse

1	88	2.286	38.50	103	2.675	38.50	0.86	0.64
2	61	3.902	15.63	67.7	4.33	15.63	0.90	0.73
3	60	3.902	15.38	67.0	4.35	15.38	0.90	0.73
4	40	5.519	7.25	47.1	6.50	7.25	0.85	0.61
5	48	5.519	8.70	50.9	5.85	8.70	0.94	0.83
6	46	5.519	8.33	50.4	6.05	8.33	0.91	0.75
							Avg.	0.72

B. Translation Velocity Predictions for Near Side-Wall

A listing of the pressure-time loading records obtained from the experiment showed that the near side-wall had the highest load values. The pressure-time records for Stations 1-6 on the near side-wall were weighted, according to wall location, and summed to obtain a total load. From this load an average pressure load was calculated for the entire near side-wall. Figure 23 shows the resulting pressure-time curves for each of the separation distances.

The digitized versions of these loads were used in a translation program which was run on a microcomputer. The assumption was made that the near-wall started to move when the pressure load was applied. This assumption was made because of the inherent structural weakness of the brick wall of the full-size magazine which was modeled.

The computer program calculated the acceleration, a , from the model and loading parameters using Equation 4 for discrete intervals of the loading-time curve, P_L vs t_i . Time intervals of 10-25 μs were used in the calculations.

$$a = 1000 \frac{A_W P_L}{M_W}, \quad (4)$$

where a is the acceleration (m/s^2) of the concrete model wall of area A_W ($0.050 m^2$) and mass M_W ($0.953 kg$) under a pressure loading of P_L measured in kPa. The incremental velocity, ΔV (m/s), was obtained from Equation 5 for an acceleration value over a time increment, $\Delta t(s)$.

$$\Delta V = a \Delta t, \quad (5)$$

where the time increment, Δt , is from a time t_1 to t_2 and so on. The incremental distance $\Delta D(m)$, is found from Equation 6.

$$\Delta D = \frac{\Delta V}{2} \Delta t, \quad (6)$$

where ΔV and Δt are defined above. The factor of 1/2 is used to average the velocity changes over the time increment. The distance is then summed with each additional velocity and time increment.

The predicted motion parameters for the near-side wall are shown in Tables 9-11. The velocities are plotted in Figure 24. Generally, the velocity initially increases quickly, then reaches a maximum velocity at the end of the positive loading phase. Shot 2 had two major peaks in the pressure-time loading, which are seen in the wall velocity-time plot. When the second loading peak arrived, at 2 ms, the velocity sharply increased and reached a maximum above that of Shot 5 after it was lower initially. The maximum wall velocities reached ranged between 7-12 m/s.

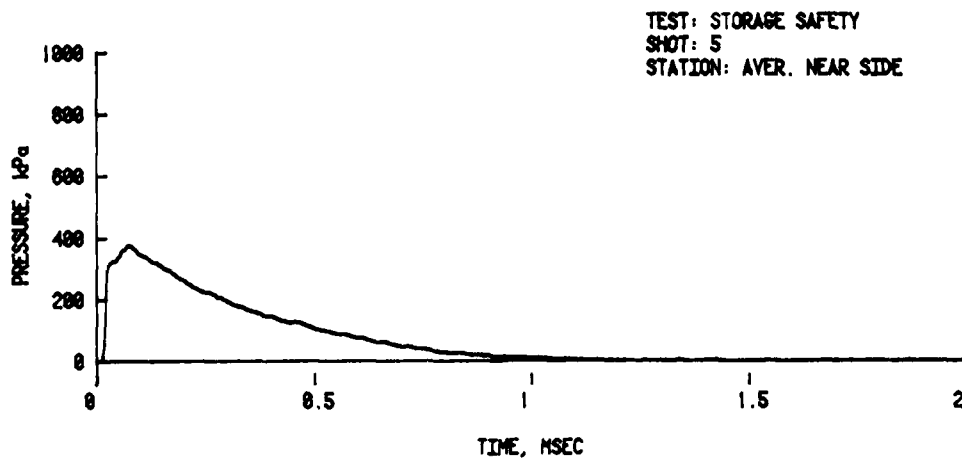
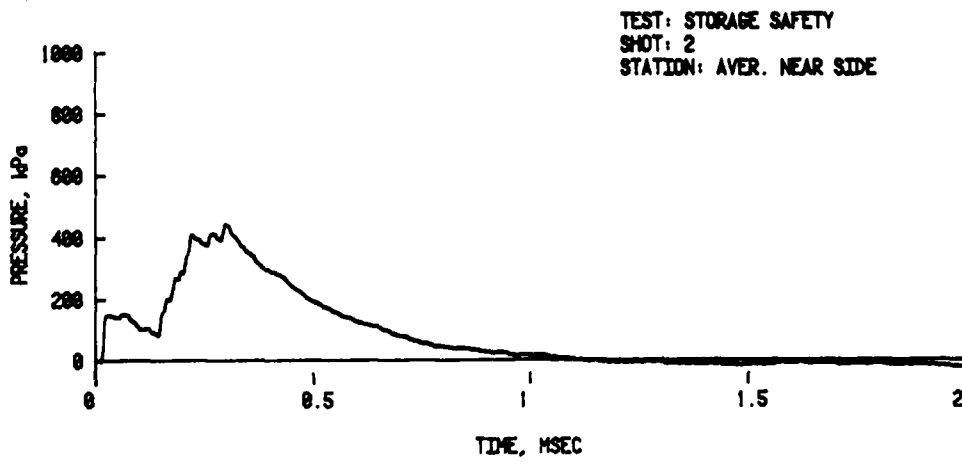
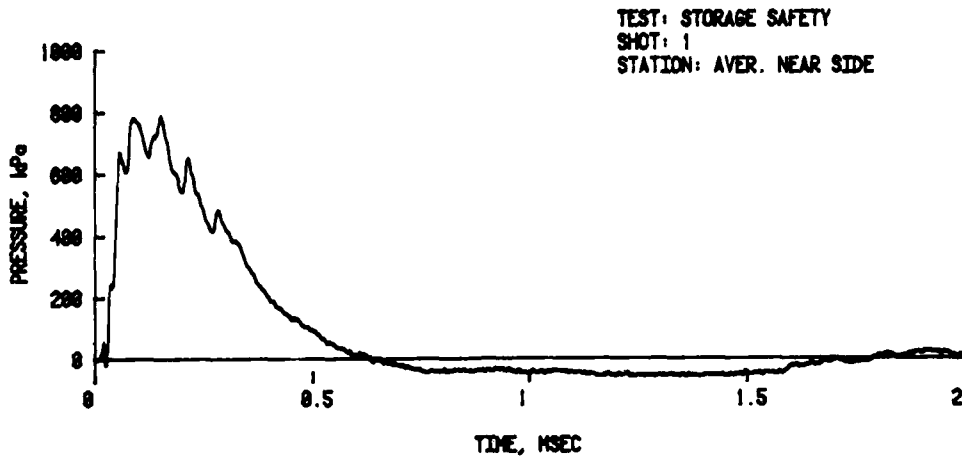

Figure 23. Average Loading on Near Side-Wall

Table 9. TRANSLATION OF NEAR SIDE-WALL, SHOT 1, $0.8 Q^{1/3}_m$

Time, ms	Distance, cm	Velocity, m/s	Acceleration, m/s^2
0.00	0.00	0.00	0
0.03	0.01	0.71	35930
0.06	0.02	1.73	35930
0.10	0.03	3.32	36350
0.15	0.04	5.28	40350
0.19	0.06	6.61	29210
0.25	0.11	8.40	24790
0.30	0.15	9.57	22020
0.35	0.20	10.46	14390
0.40	0.25	11.02	9910
0.45	0.35	11.38	5600
0.50	0.36	11.57	2670
0.55	0.42	11.63	800
0.58	0.45	11.64	107

Table 10. TRANSLATION OF NEAR SIDE-WALL, SHOT 2, $1.6 Q^{1/3}$

Time, ms	Distance, cm	Velocity, m/s	Acceleration, m/s^2
0.00	0.00	0.00	0
0.03	0.00	0.19	7730
0.08	0.00	0.58	8000
0.10	0.01	0.74	6400
0.15	0.02	0.93	9530
0.19	0.03	1.36	15030
0.25	0.04	2.76	21590
0.29	0.05	3.27	19990
0.35	0.06	4.94	23450
0.45	0.10	6.84	15780
0.55	0.19	8.13	10450
0.65	0.27	8.96	7090
0.75	0.37	9.51	4420
0.85	0.47	9.83	2560
0.95	0.55	10.03	1870
1.08	0.65	10.16	910
1.12	0.75	10.19	267

Table 11.

TRANSLATION OF NEAR SIDE-WALL, SHOT 5, $2.4 Q^{1/3} m$

Time,ms	Distance,cm	Velocity, m/s	Acceleration, m/s ²
0.00	0.00	0.00	0
0.03	0.01	0.43	17060
0.08	0.02	1.38	20040
0.15	0.03	2.69	16470
0.20	0.04	3.43	14130
0.25	0.05	4.05	11990
0.30	0.07	4.60	10390
0.35	0.10	5.06	8850
0.40	0.12	5.45	7680
0.45	0.15	5.79	6660
0.50	0.17	6.09	5700
0.55	0.02	6.34	4690
0.60	0.22	6.53	3739
0.65	0.28	6.69	3200
0.70	0.30	6.82	2400
0.75	0.33	6.92	1870
0.85	0.42	7.06	1170
0.95	0.50	7.13	590
1.05	0.55	7.18	320
1.15	0.70	7.21	107
1.25	0.75	7.22	80
1.35	0.80	7.22	53

None of these maximum velocities appears great enough to initiate candidate munitions (Reference 1) that may be stored in this type of above ground, barricaded storage magazine.

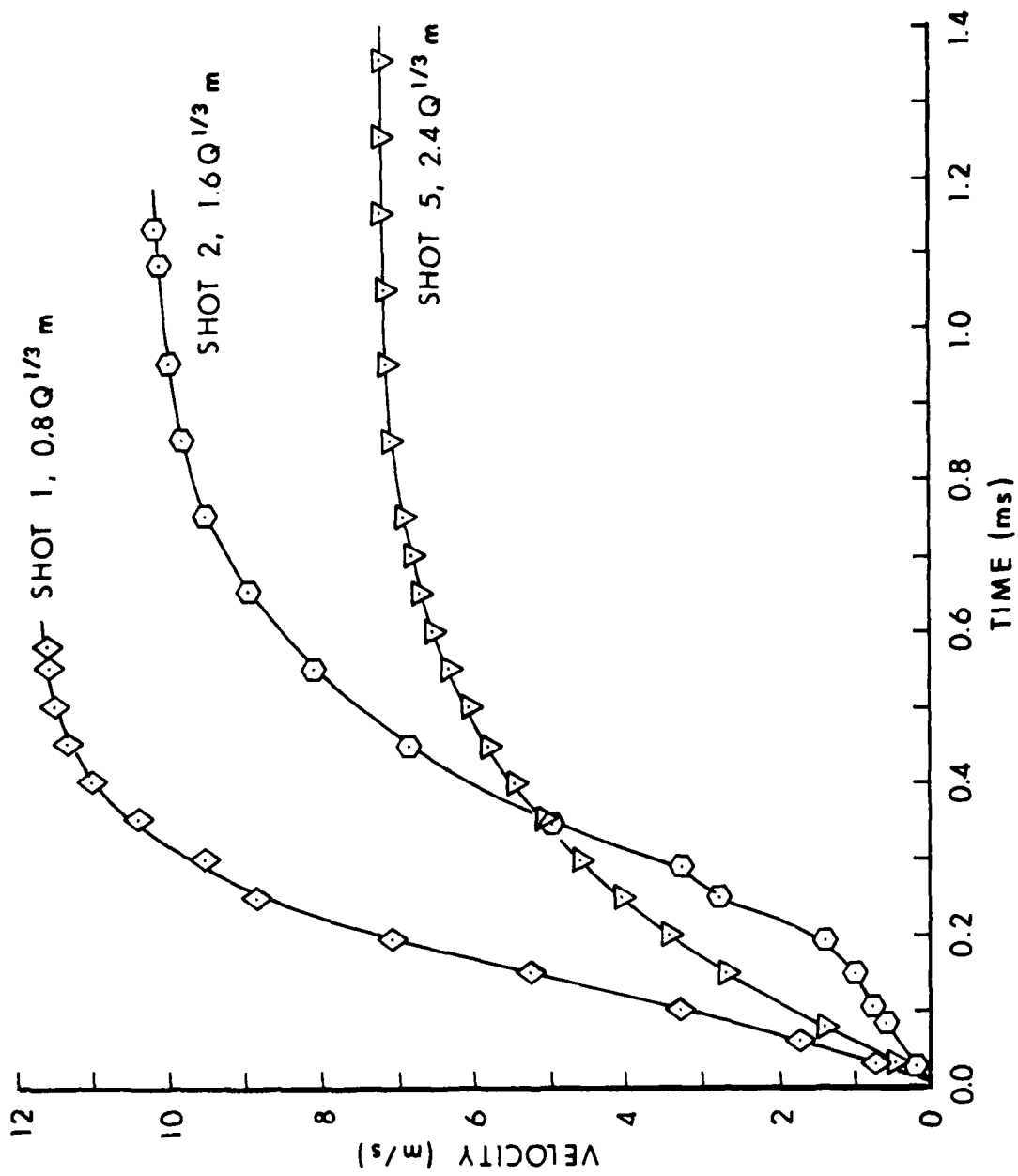

Figure 24. Predicted Translational Velocity of Near Side-Wall

SUMMARY AND CONCLUSIONS

A test series of six shots was fired with 1 kg bare 50/50 Pentolite hemispherical charges placed inside model concrete donor magazines. Measurements of pressure-time loading were obtained at several locations on a nonresponding barricaded model acceptor magazine. The experimental models were constructed at 1/23.5 scale of the full sized above ground barricaded munition storage magazine on site at Machrihanish, Scotland.

Calculations of charge suppression factors for Station 20 (using a pressure method), caused by the cover of the concrete donor model over the base charge, indicate values around 0.43 kg. A 0.43 kg free-field base hemispherical charge would have pressure equivalency to the covered 1 kg charge used during the experiments. At the greater distances, as calculated for Station 21, the average charge suppression factor was 1.02 kg indicating little or no effect of the donor model cover, or of the barricades around the model.

Whole wall translation velocities, calculated from the average near side-wall loading, ranged from 7-12 m/s. These low predicted velocities seem to be born out from the results of a preliminary shot with a responding concrete acceptor model magazine. Component wall debris translation appeared to be minimal. Tentatively, the observed and calculated values for the near side-wall (the highest loaded surface) velocities, indicated that the components of the wall would not attain hazardous velocities as quoted in the literature. This was true at a standard safe separation distance of $0.8 Q^{1/3}$ m. It would appear not necessary to increase the separation distance from this value to any larger separation distance. The $0.8 Q^{1/3}$ m separation distance appears adequate.

Further experiments are planned to better determine the velocities of wall debris from a number of responding model acceptor walls. Time constraints of the present experiments allowed only preliminary debris results to be obtained.

ACKNOWLEDGMENT

The authors wish to thank Mr. Kenneth Holbrook for the very extensive site and model preparation and also for being the explosive handler for the test series.

REFERENCES

1. F. B. Porzel and J. M. Ward, "Explosive Safety Analysis of the Machrihanish Magazine," NSWC TR 79-359, December 1979.
2. Charles N. Kingery, Gerald Bulmash, and Peter Muller, "Blast Loading on Above Ground Barricaded Munition Storage Magazines," Ballistic Research Laboratory Technical Report ARBRL-TR-0257, May 1984 (A141677).
3. "Structures to Resist the Effects of Accidental Explosions," Dept. of the Army Technical Manual TM 5-1300, June 1969.
4. Charles N. Kingery and Gerald Bulmash, "Airblast Parameters from TNT Spherical Air Burst and Hemispherical Surface Burst," Ballistic Research Laboratory Technical ARBRL-TR-02555, April 1984 (BO 82713).
5. Wilfred E. Baker, Explosions in Air, University of Texas Press, Austin, TX, 1973.

APPENDIX

PRESSURE-TIME RECORDS

LIST OF FIGURES

Figure	Page
A-1. Pressure-Time Records for Shot 1, Separation Distance $0.8 Q^{1/3}$ m	61
A-2. Pressure-Time Records for Shot 2, Separation Distance $1.6 Q^{1/3}$ m	68
A-3. Pressure-Time Records for Shot 3, Separation Distance $1.6 Q^{1/3}$ m	75
A-4. Pressure-Time Records for Shot 4, Separation Distance $2.4 Q^{1/3}$ m	83
A-5. Pressure-Time Records for Shot 5, Separation Distance $2.4 Q^{1/3}$ m	91
A-6. Pressure-Time Records for Shot 6, Separation Distance $2.4 Q^{1/3}$ m	98

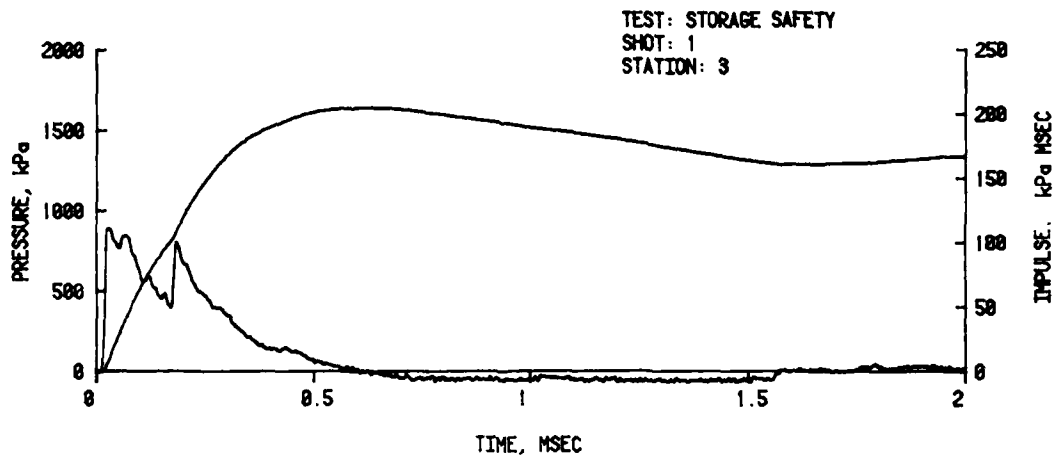
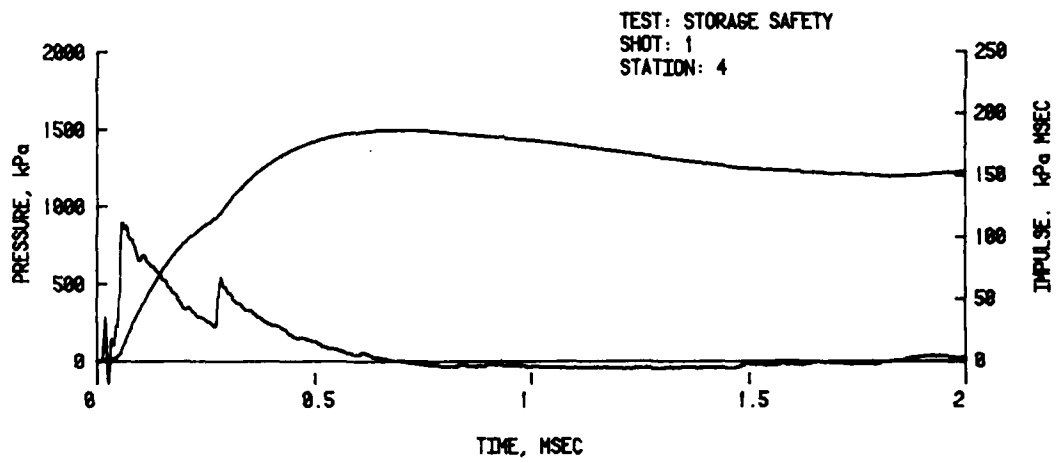
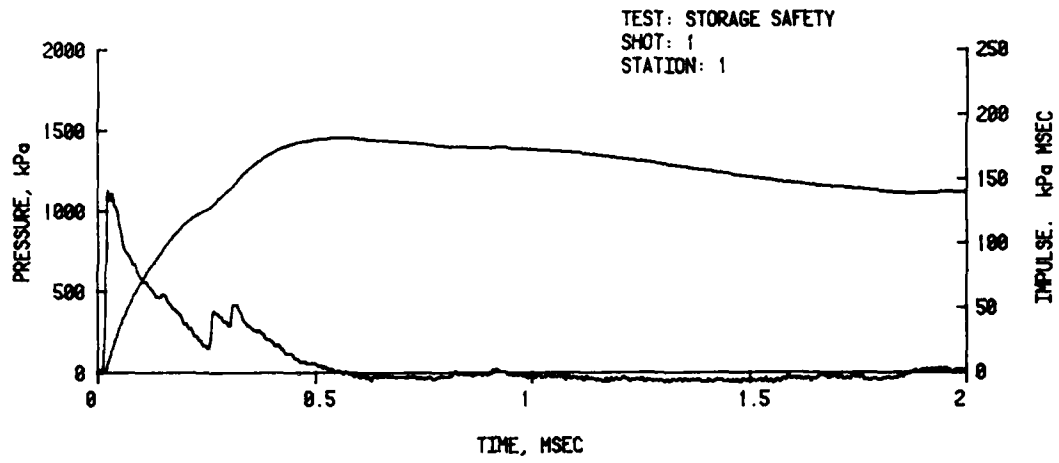

A. Near Side-Wall

Figure A-1. Pressure-Time Records for Shot 1,
Separation Distance $0.8 Q^{1/3}$ m

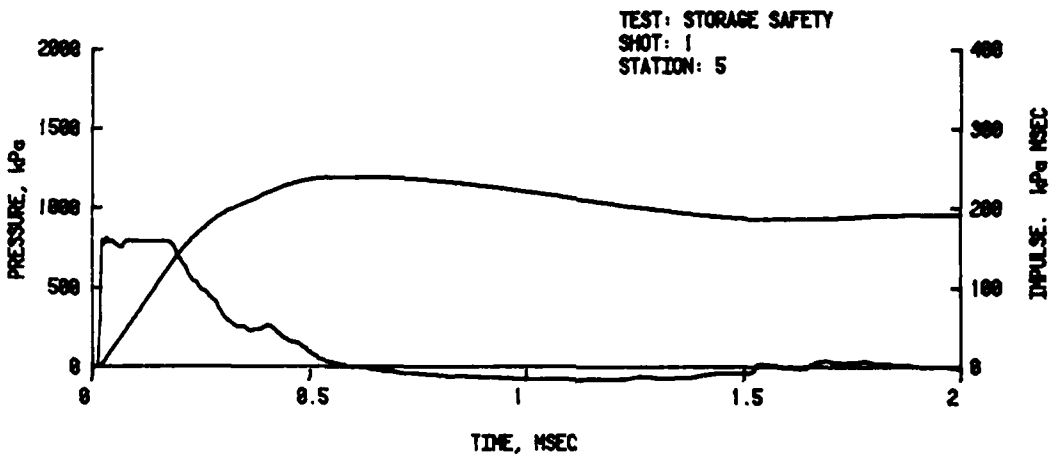
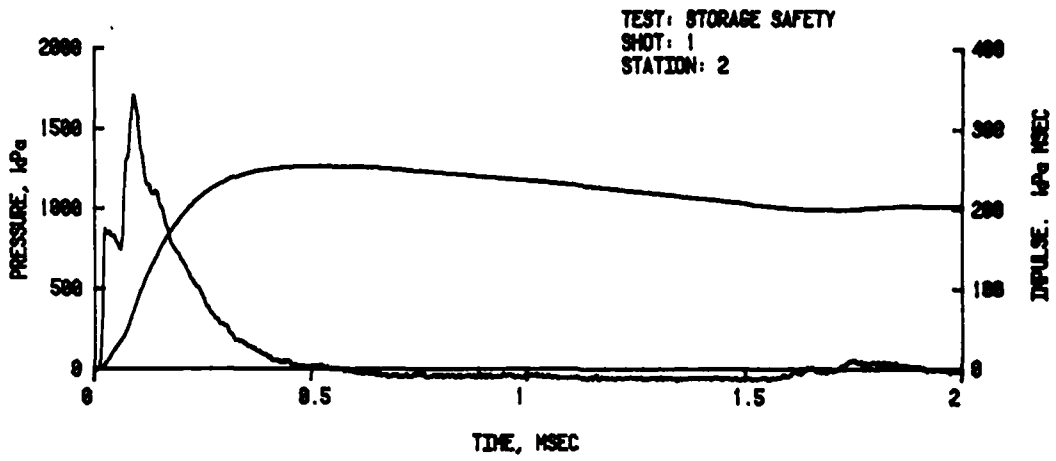

A. Near Side-Wall (Cont)

Figure A-1. (Cont.)

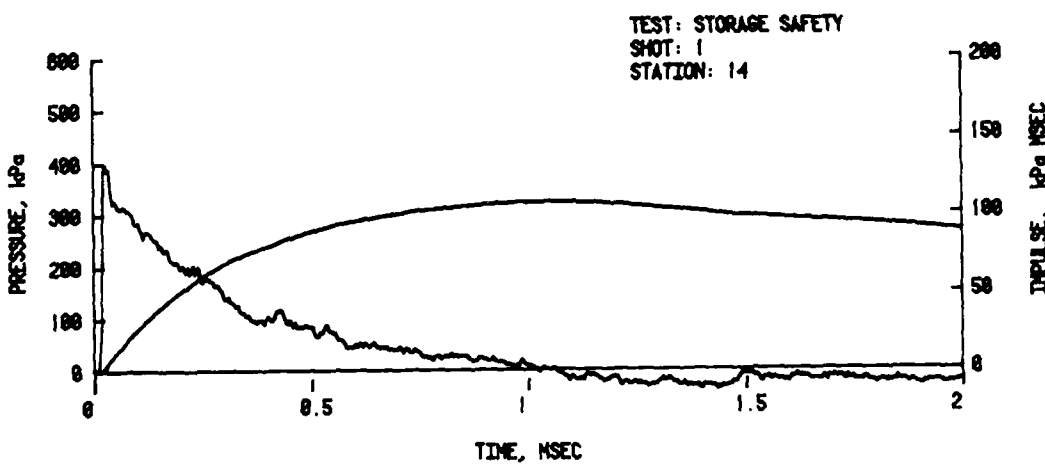
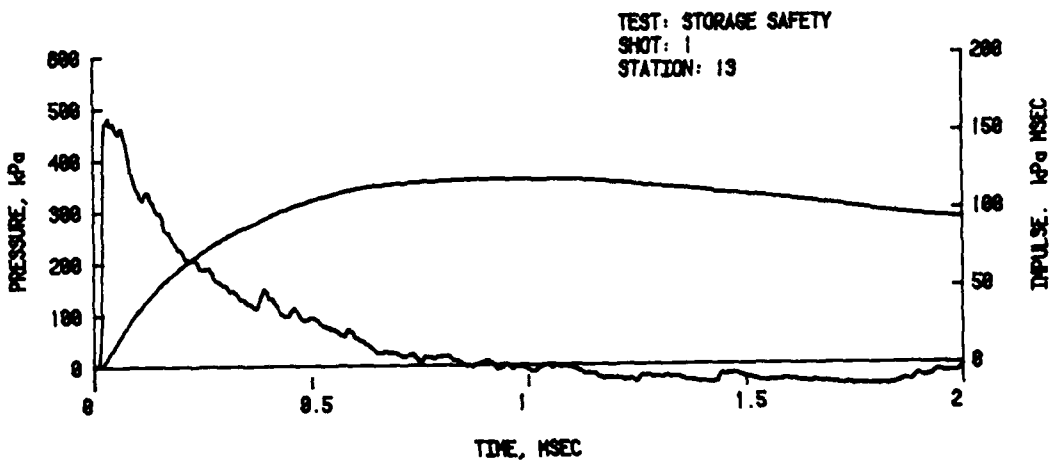
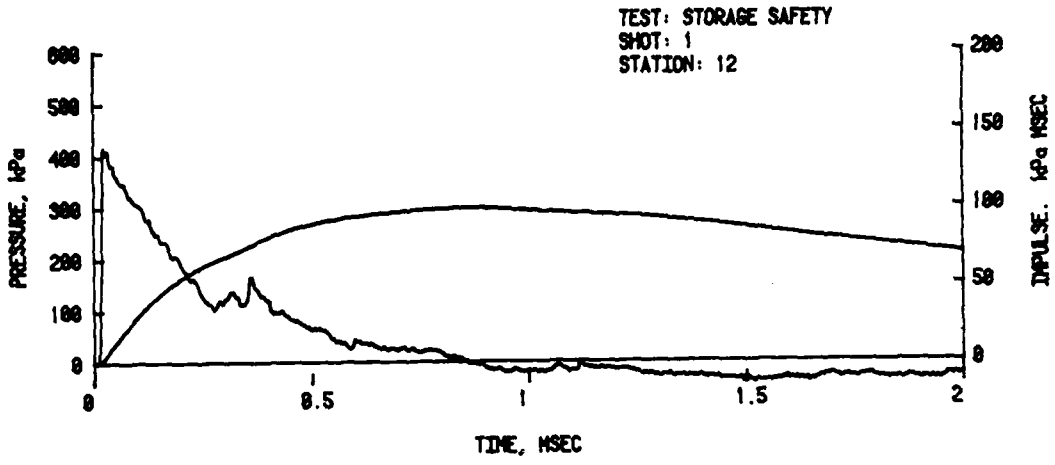

B. Roof

Figure A-1.(Cont.)

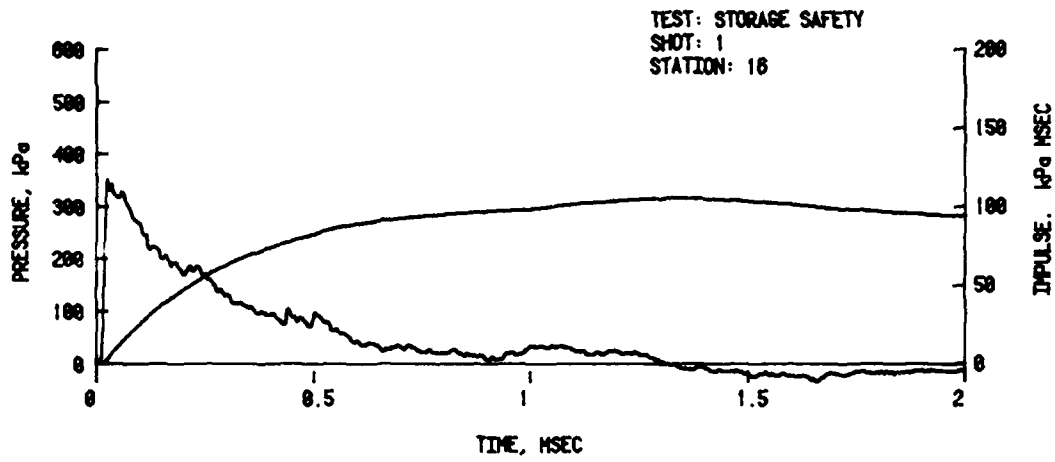
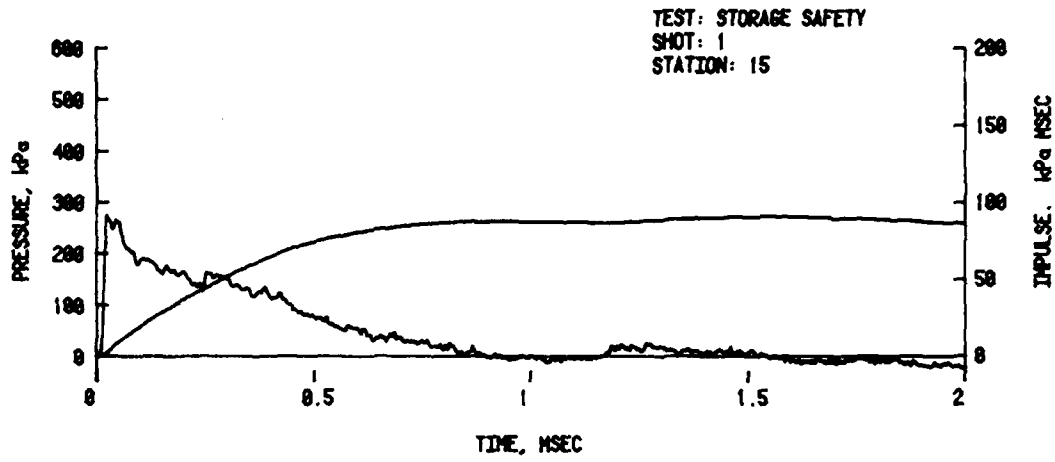

B. Roof (Cont.)

Figure A-1. (Cont.)

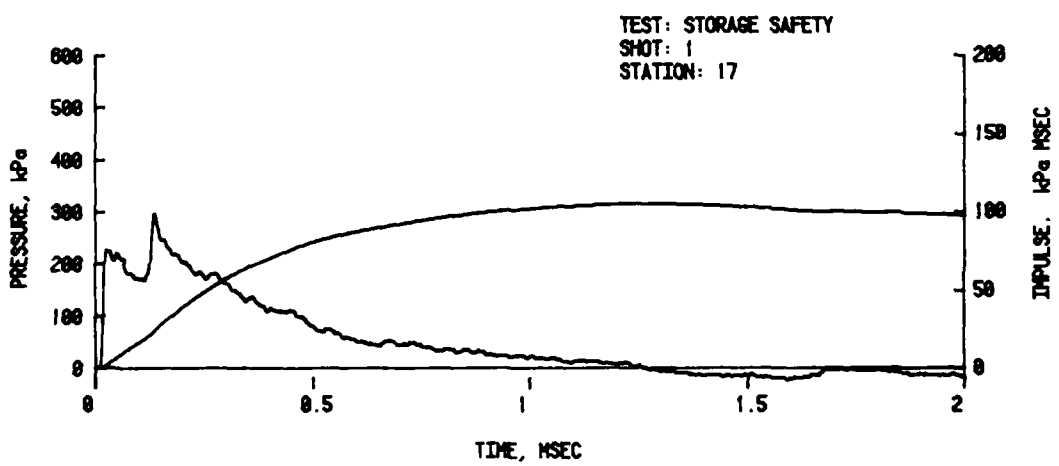
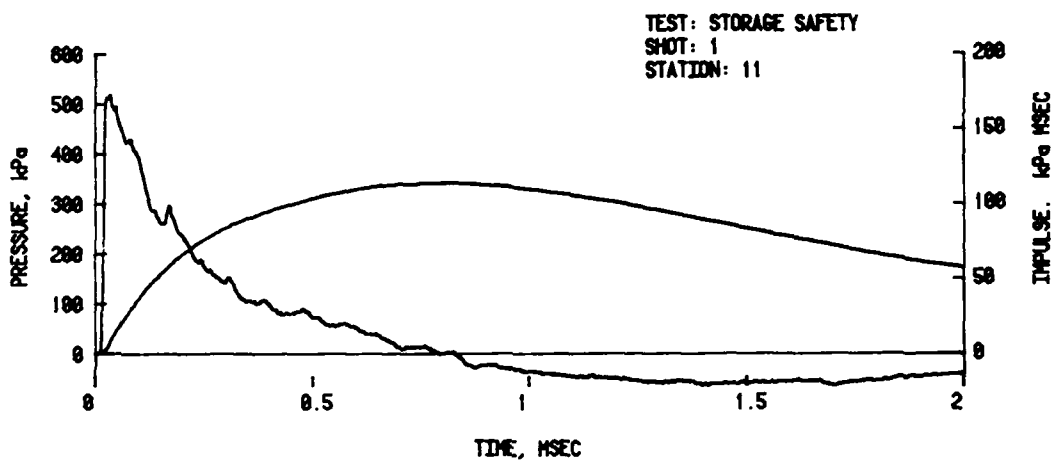
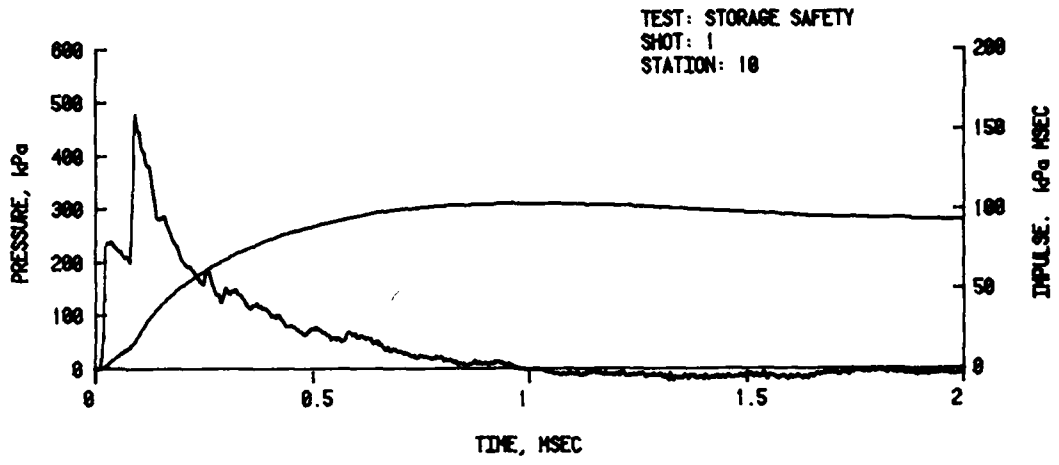

C. End Walls

Figure A-1. (Cont.)

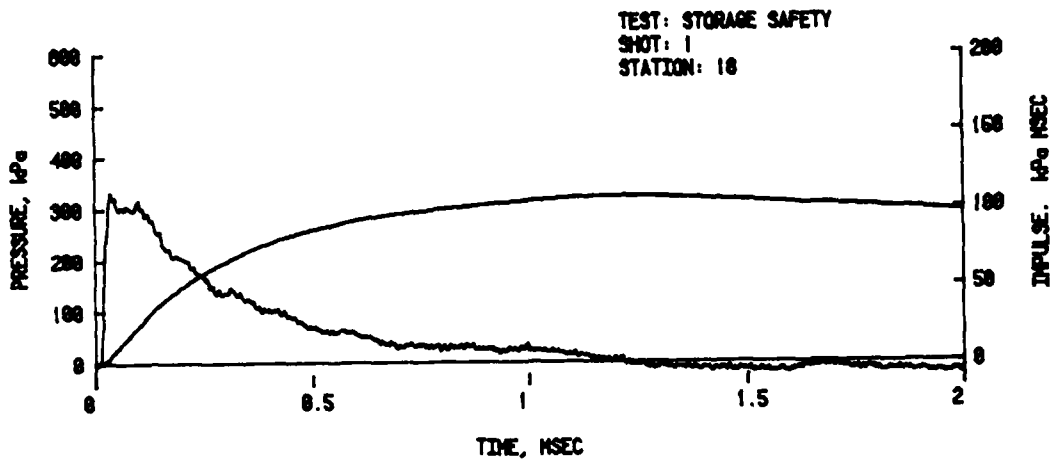

C. End Walls (Cont.)

Figure A-1. (Cont.)

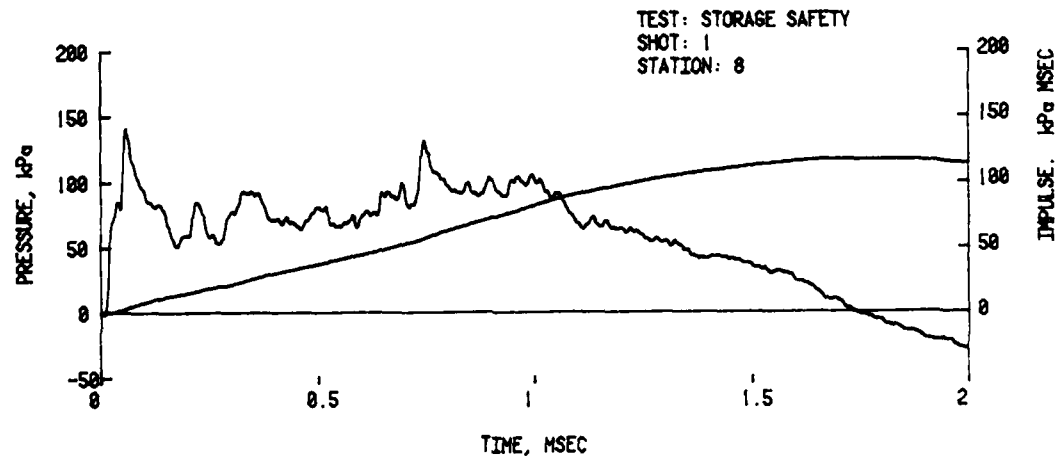
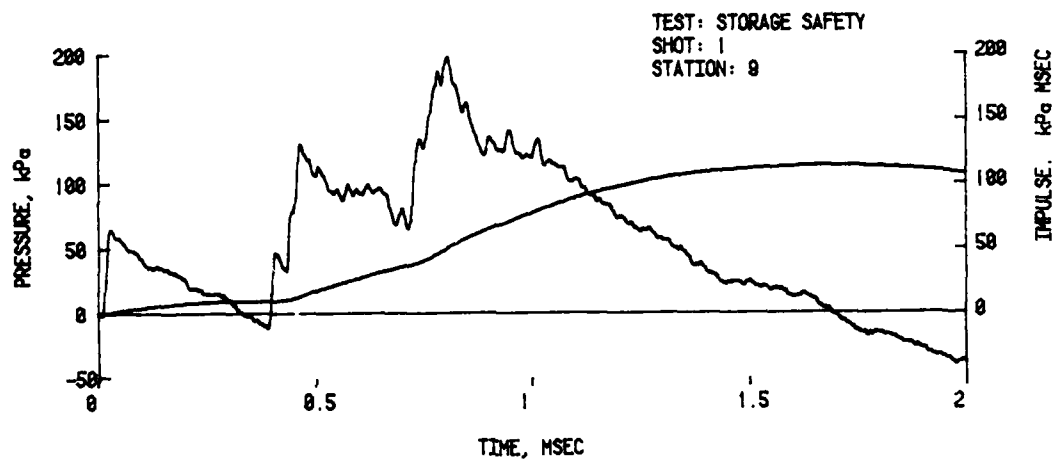
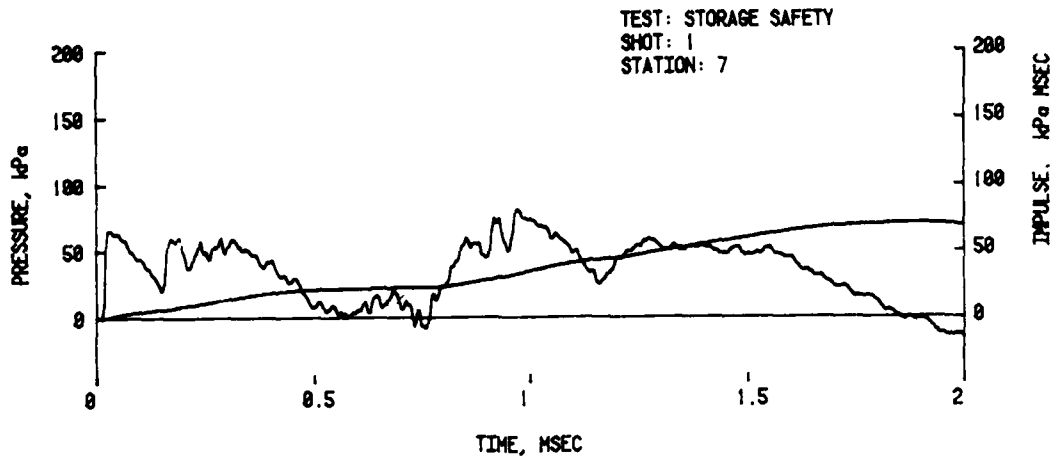

D. Far Side-Wall

Figure A-1. (Cont.)

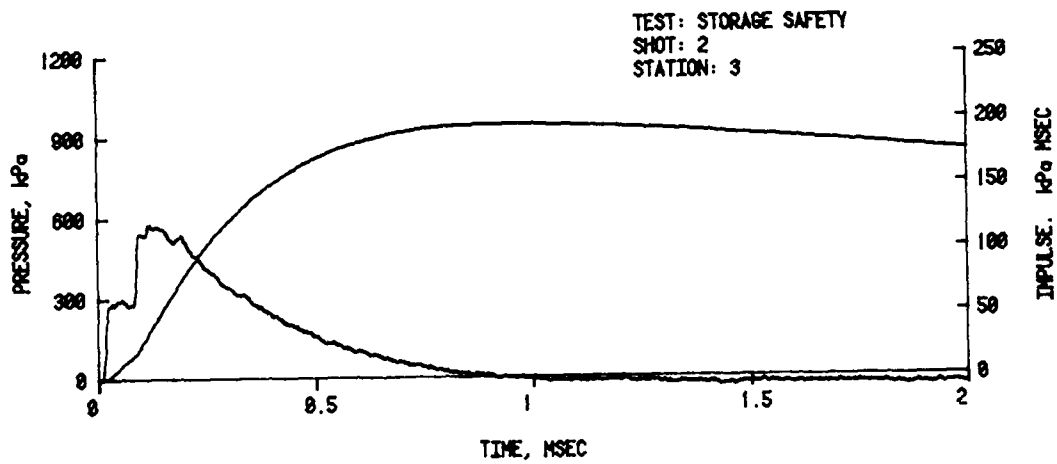
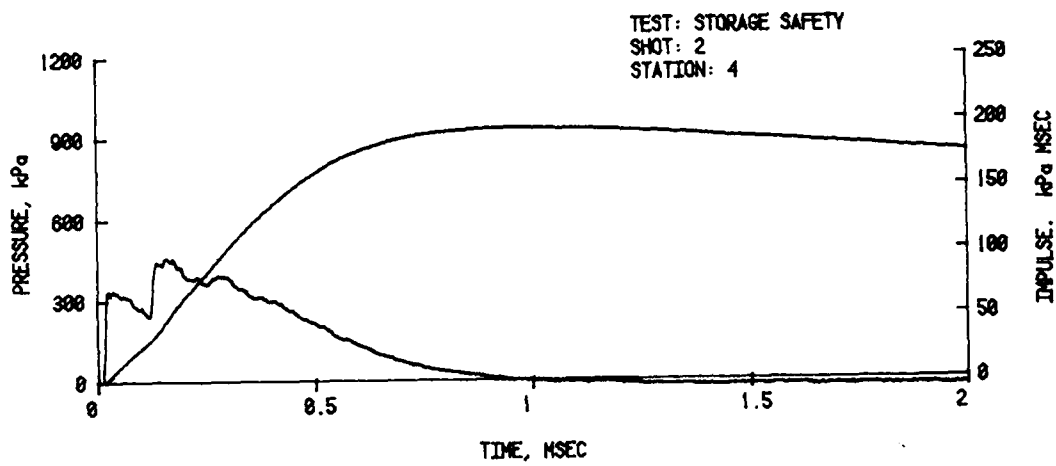
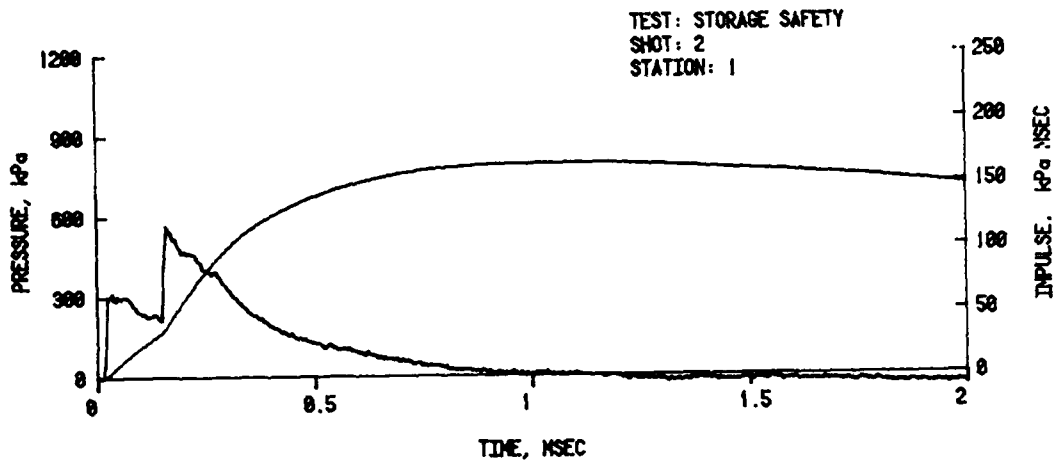

A. Near Side-Wall

FigureA-2. Pressure-Time Records for Shot 2,
Separation Distance $1.6 Q^{1/3}$ m

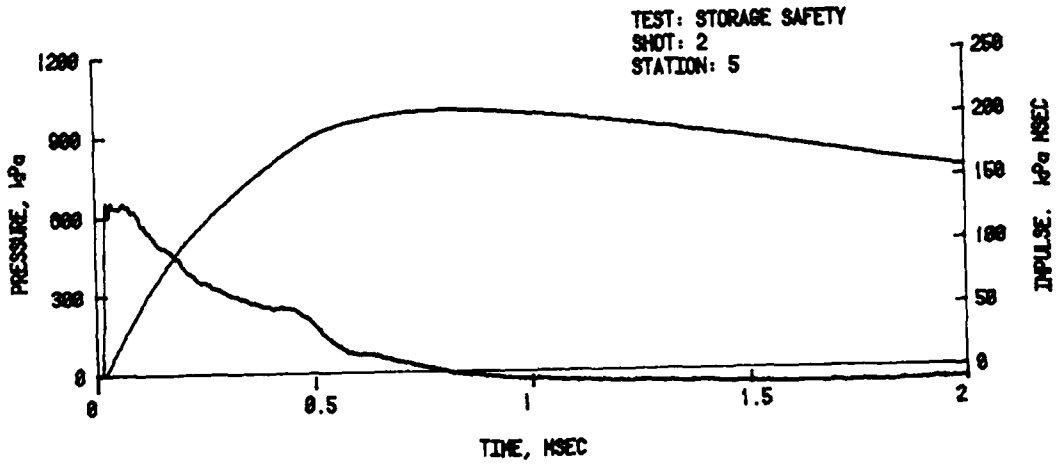
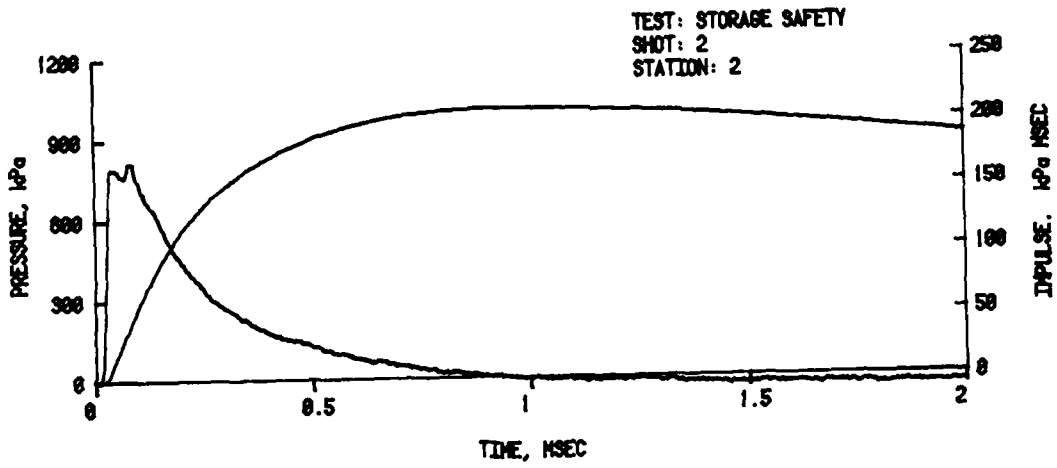
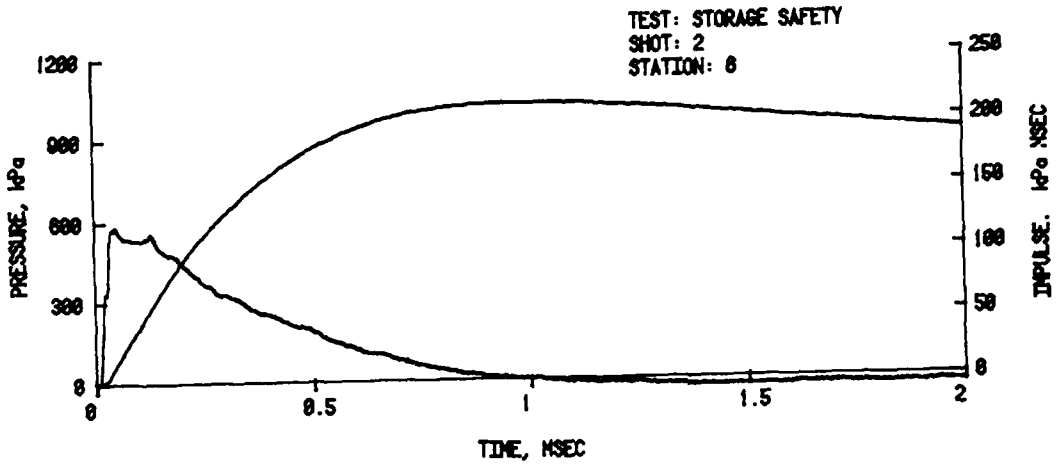

A. Near Side-Wall (Cont.)

Figure A-2. (Cont.)

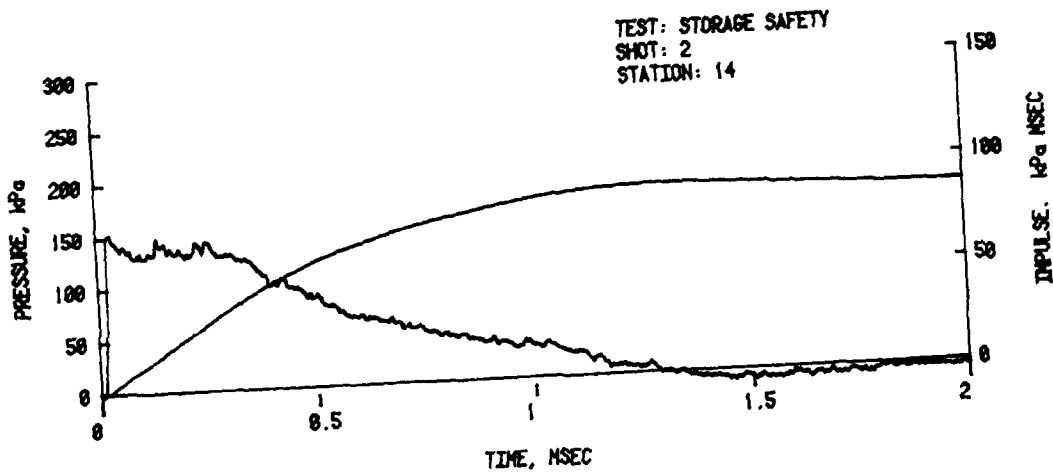
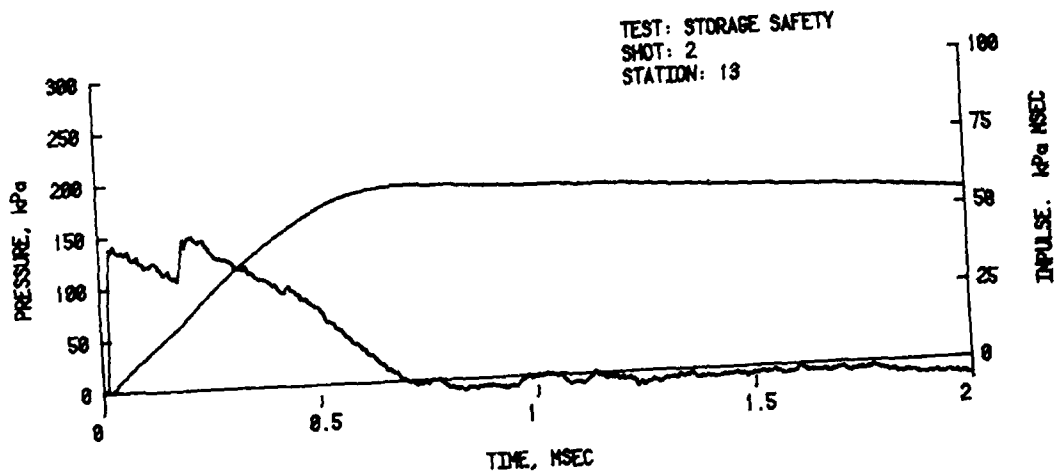
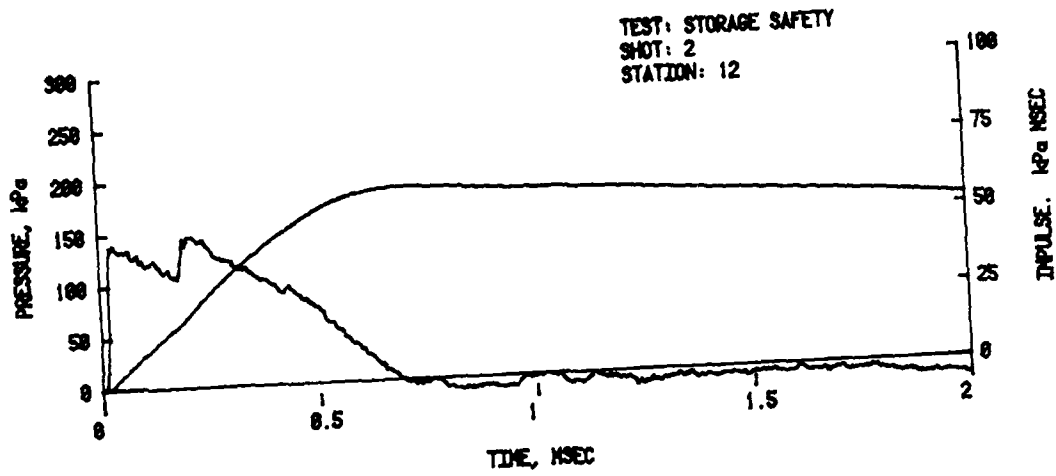

B. Roof

Figure A-2. (Cont.)

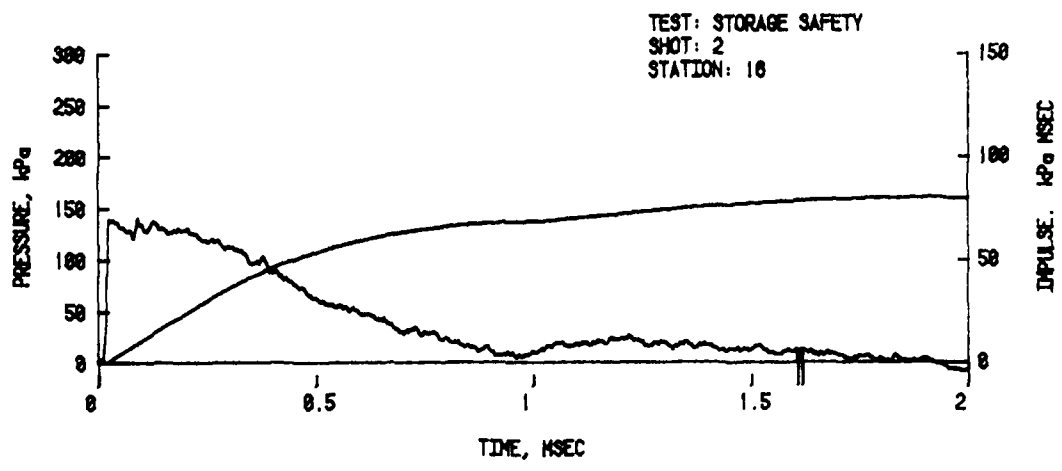
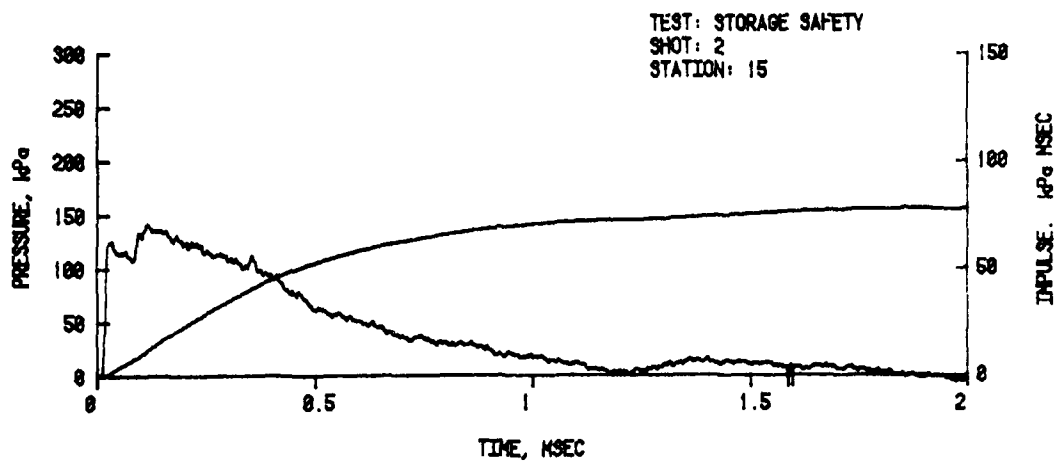

B. Roof (Cont.)

Figure A-2. (Cont.)

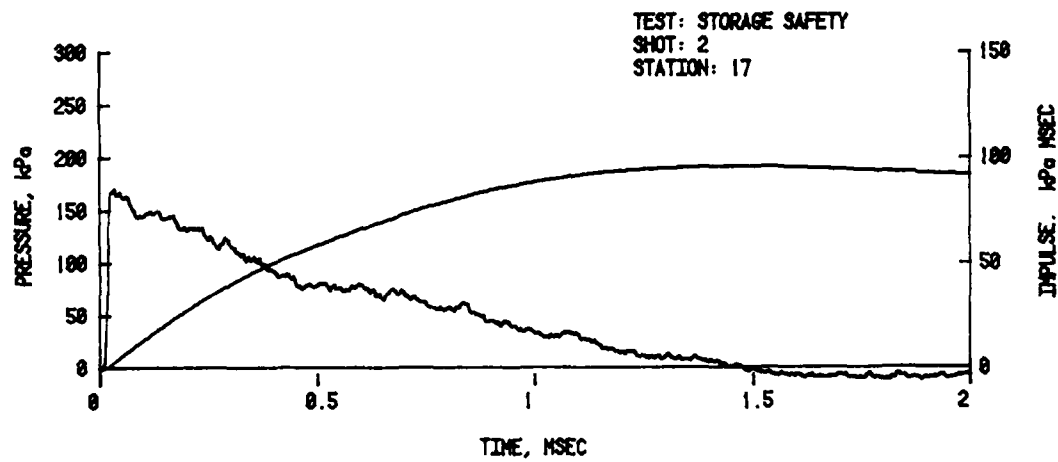
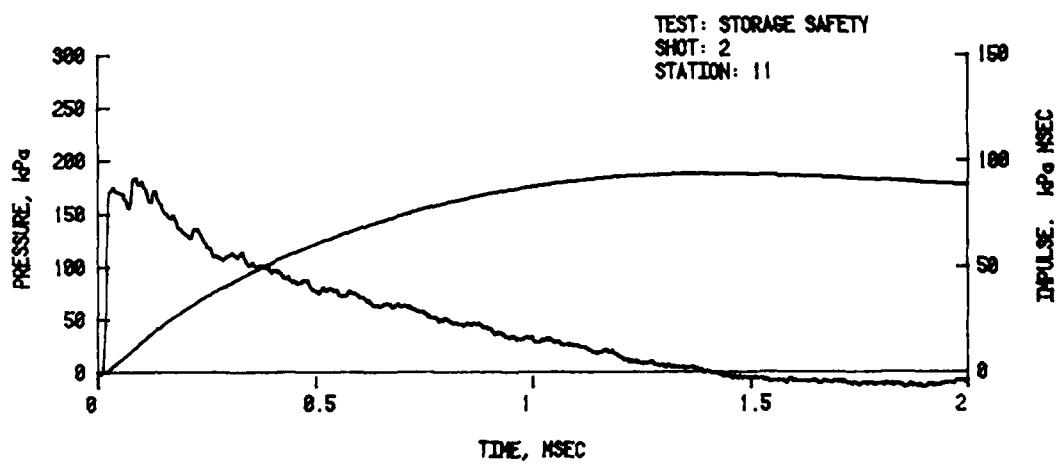
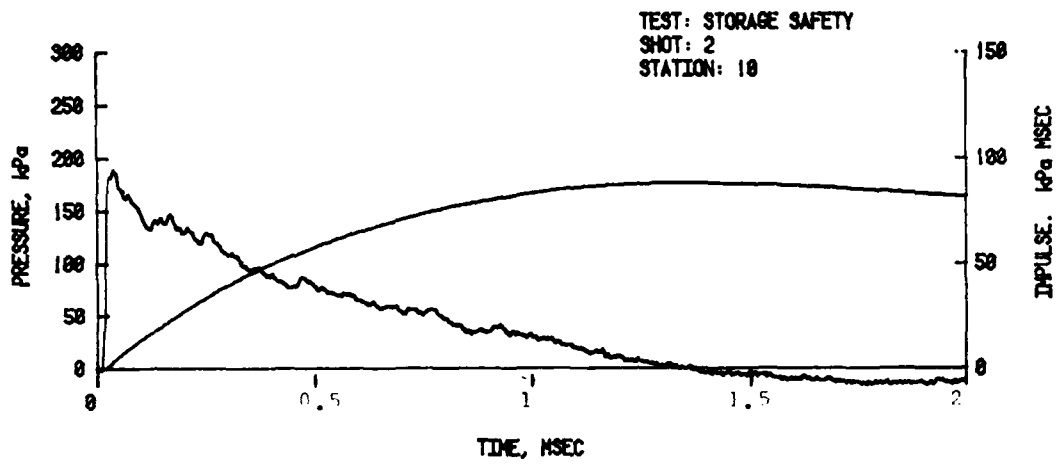

C. End Walls

Figure A-2. (Cont.)

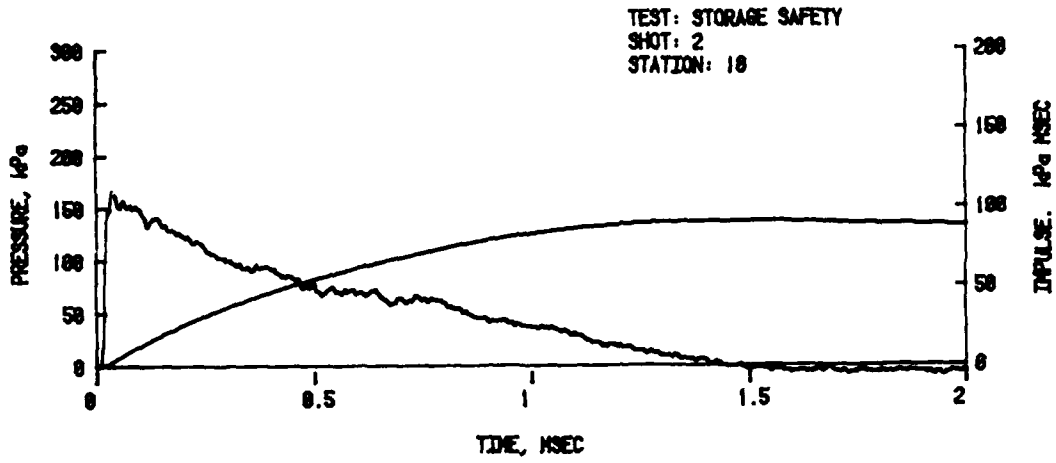

C. End Walls (Cont.)

Figure A-2. (Cont.)

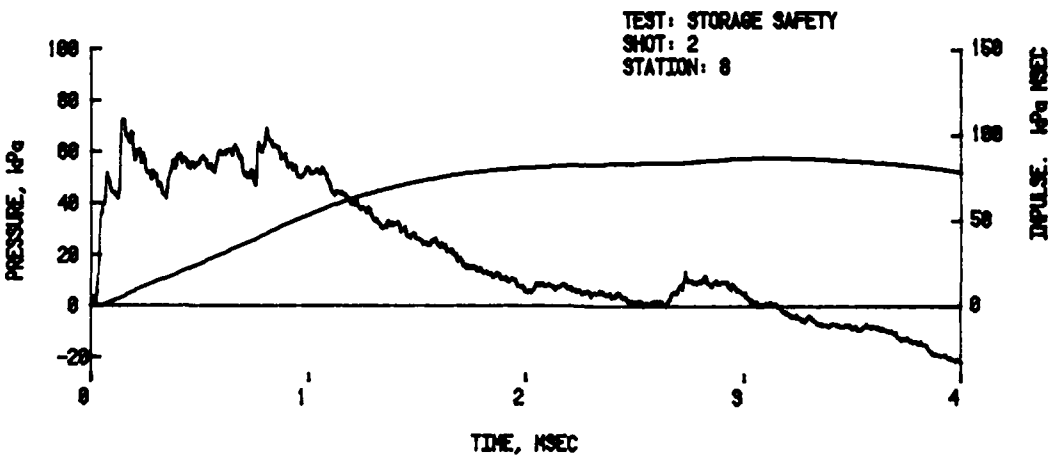
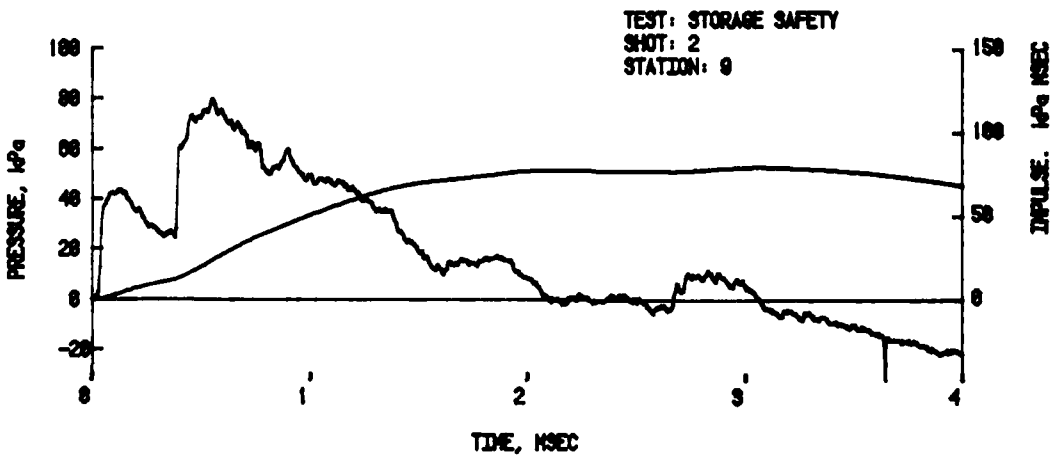
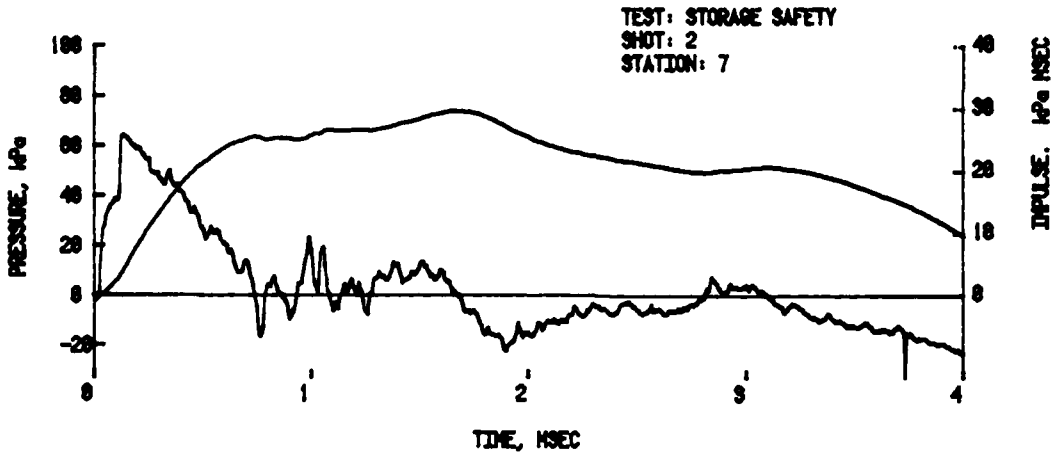

D. Far Side-Wall

Figure A-2. (Cont.)

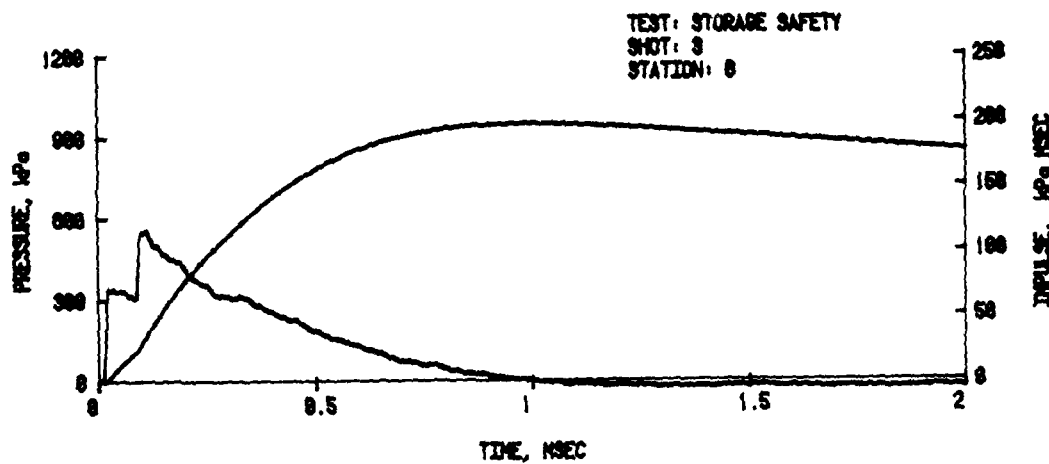
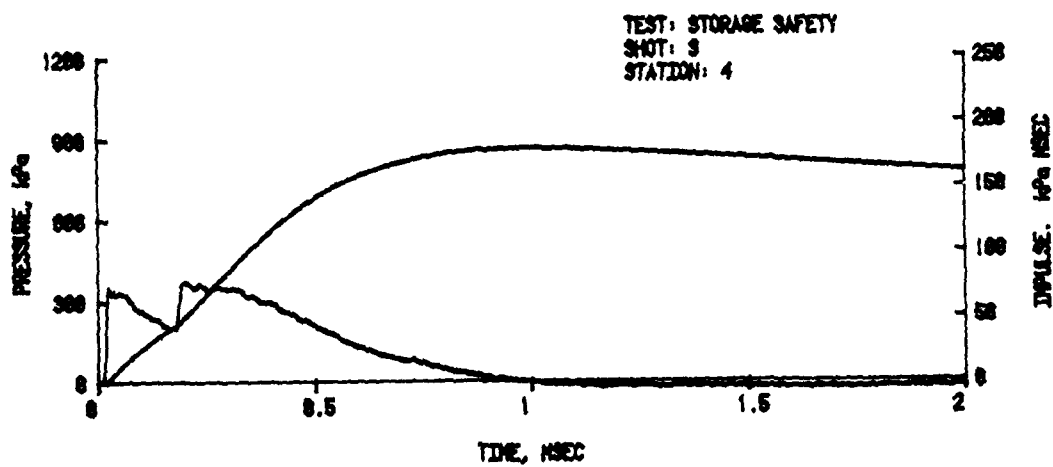
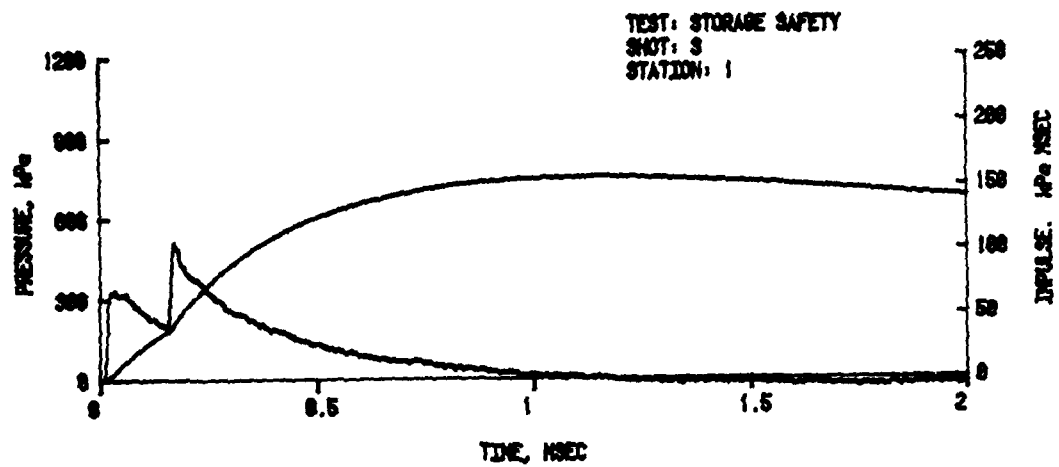

A. Near Wall

Figure A-3. Pressure-Time Records for Shot 3;
Separation Distance $1.6 Q^{1/3}$ m

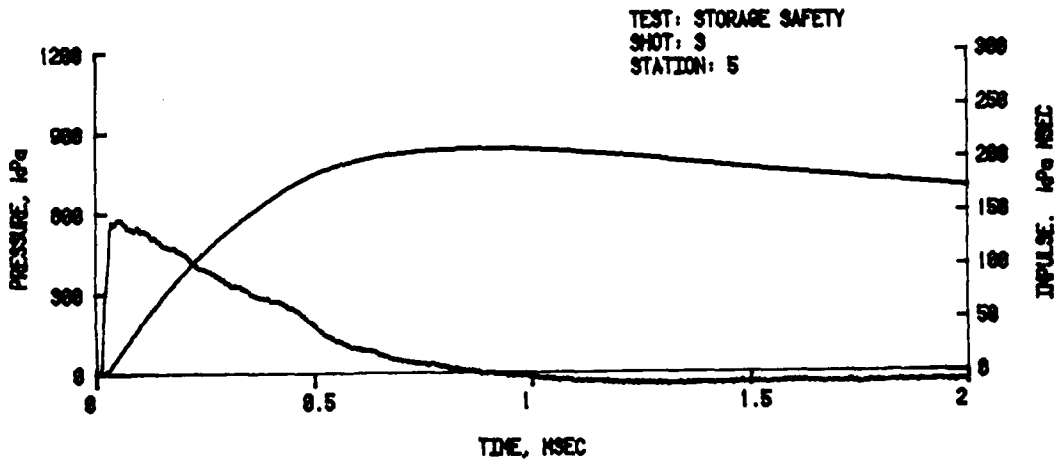
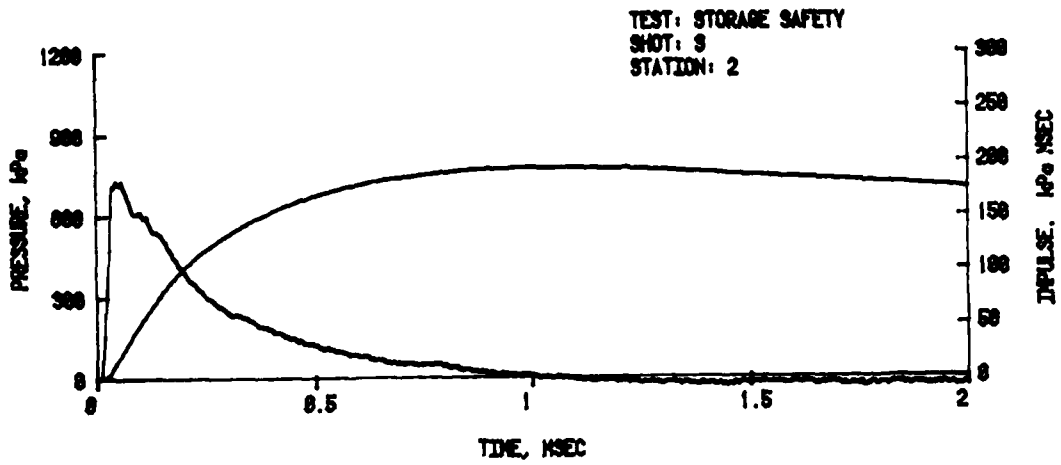

A. Near Wall (Cont.)

Figure A-3. (Cont.)

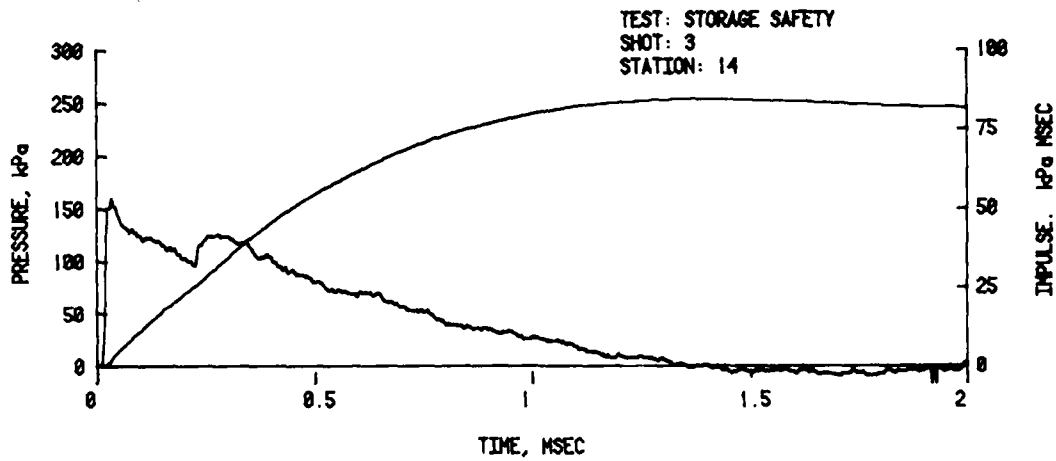
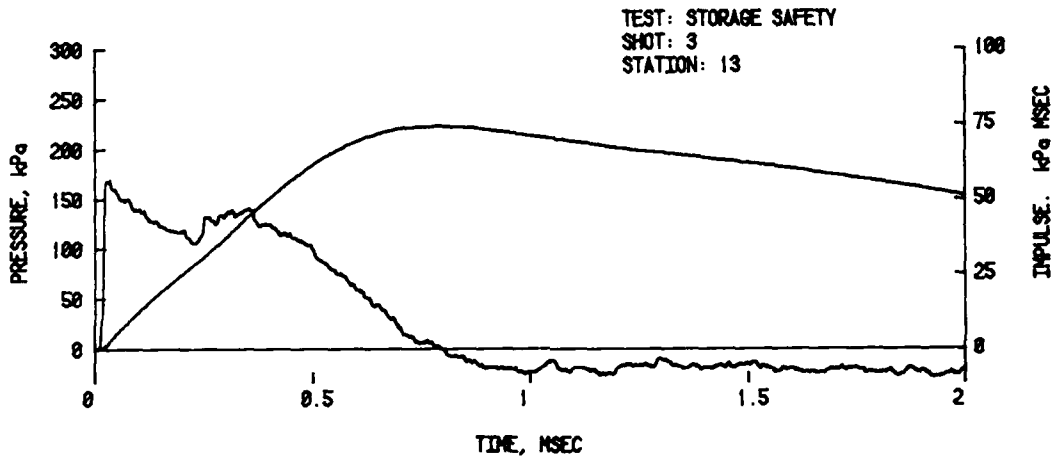
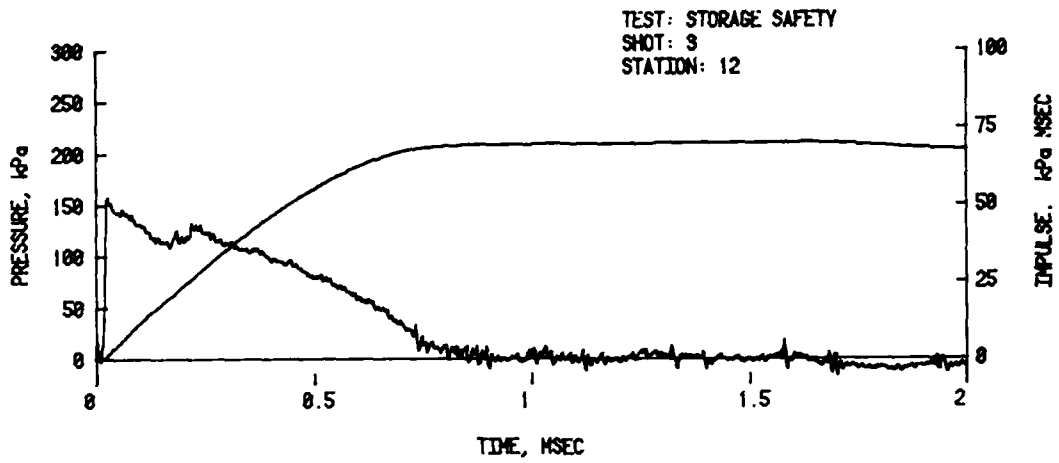

B. Roof

Figure A-3. (Cont.)

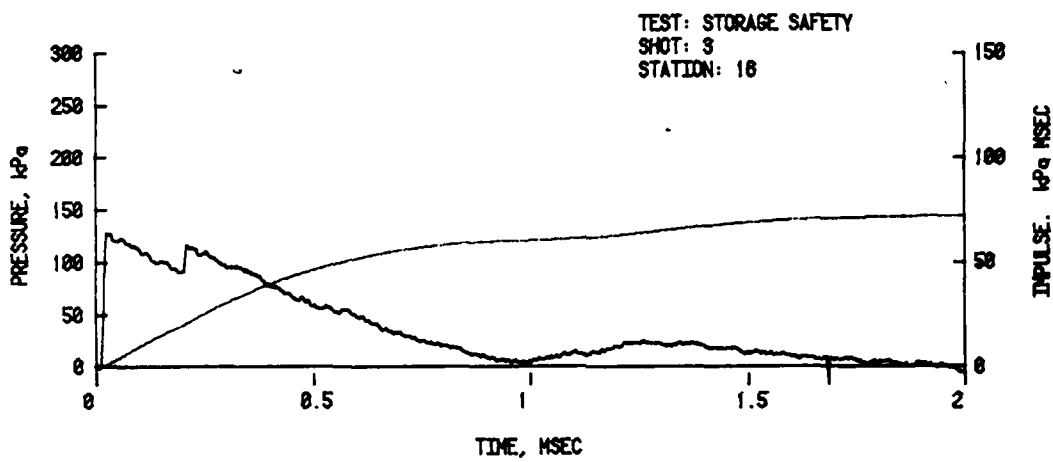
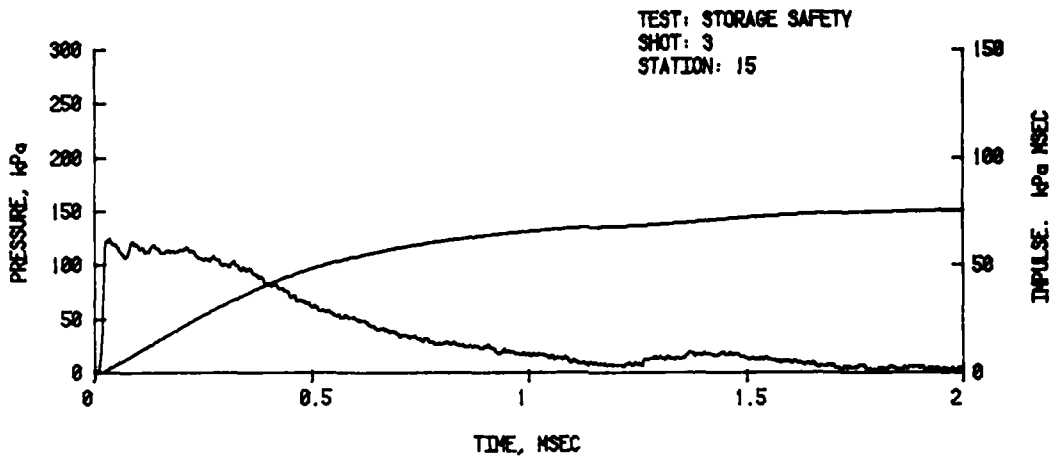

B. Roof (Cont.)

Figure A-3. (Cont.)

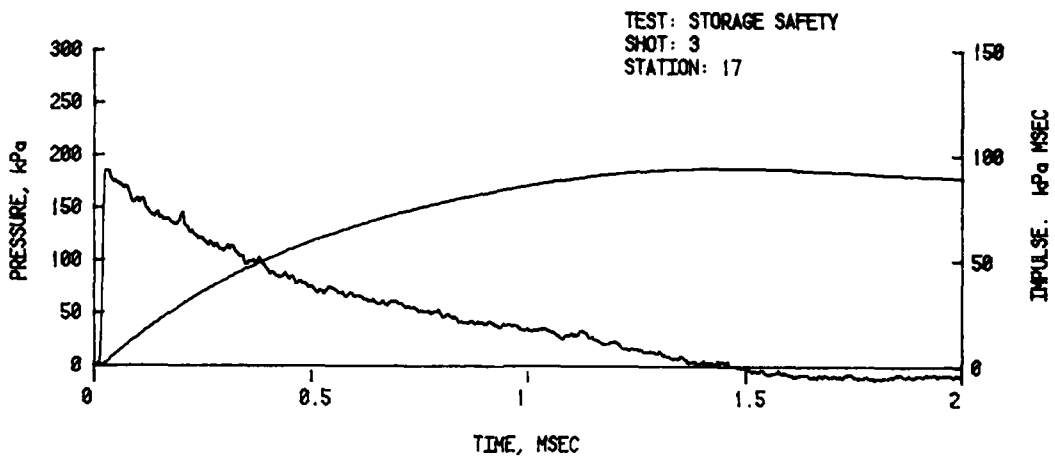
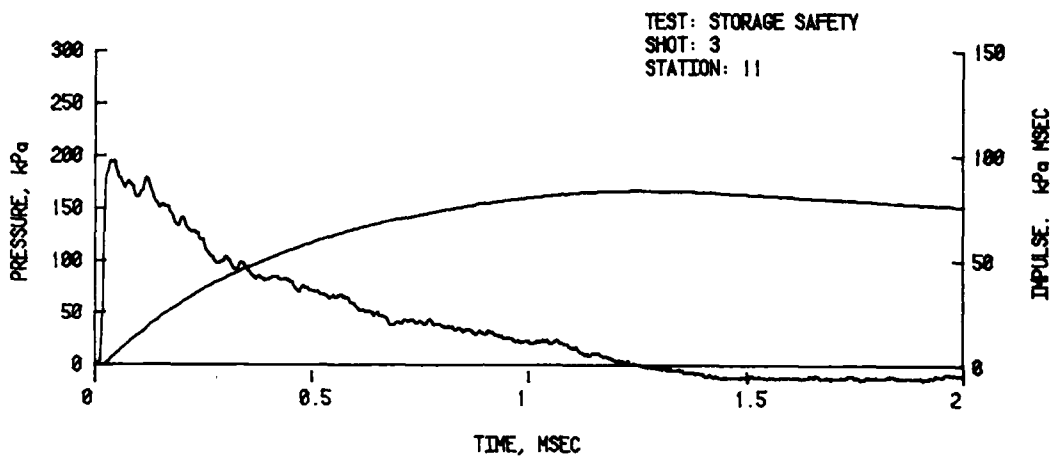
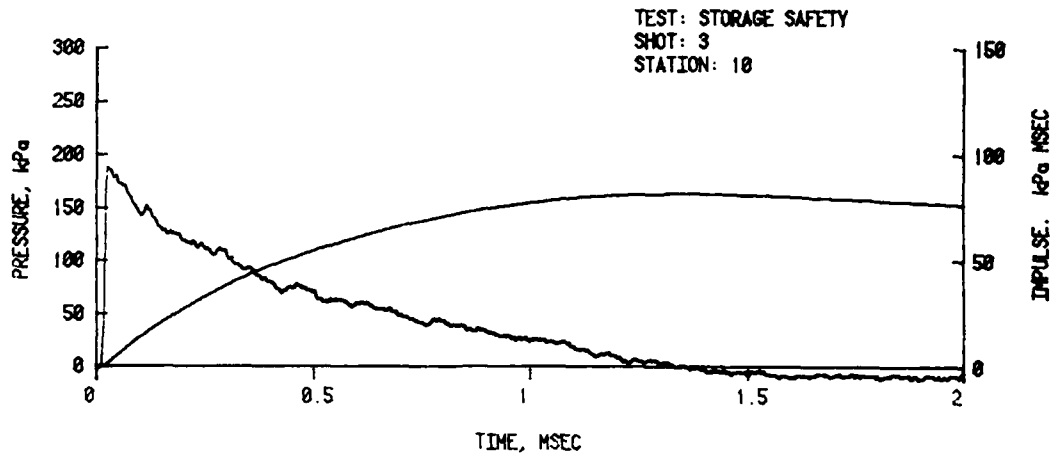

C. End Walls

Figure A-3. (Cont.)

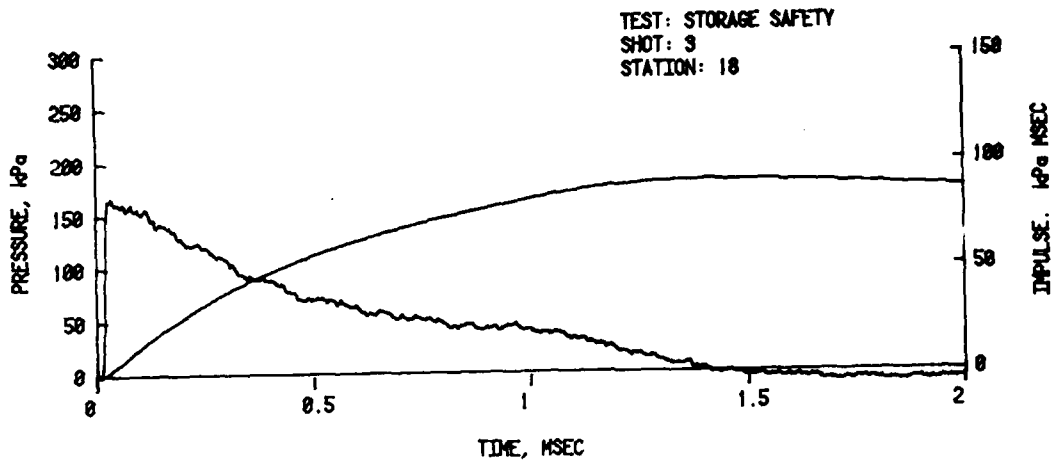

C. End Walls (Cont.)

Figure A-3. (Cont.)

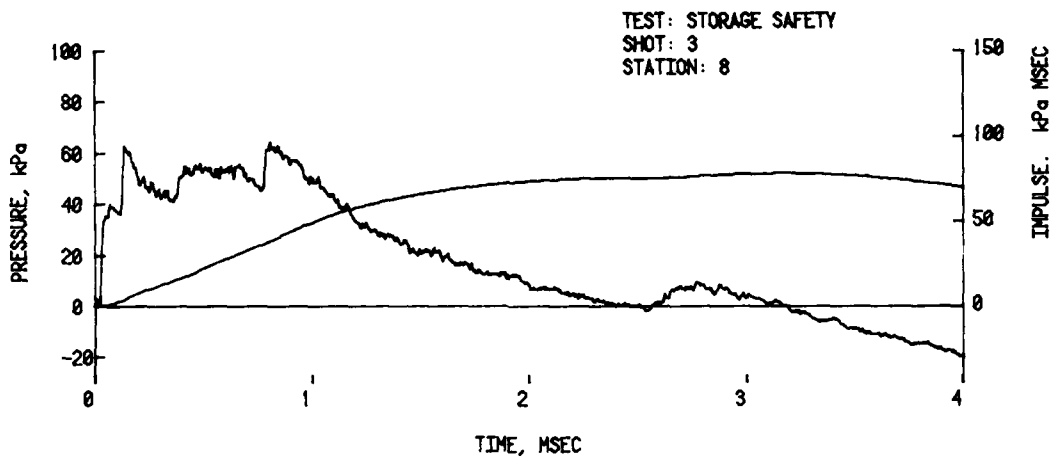
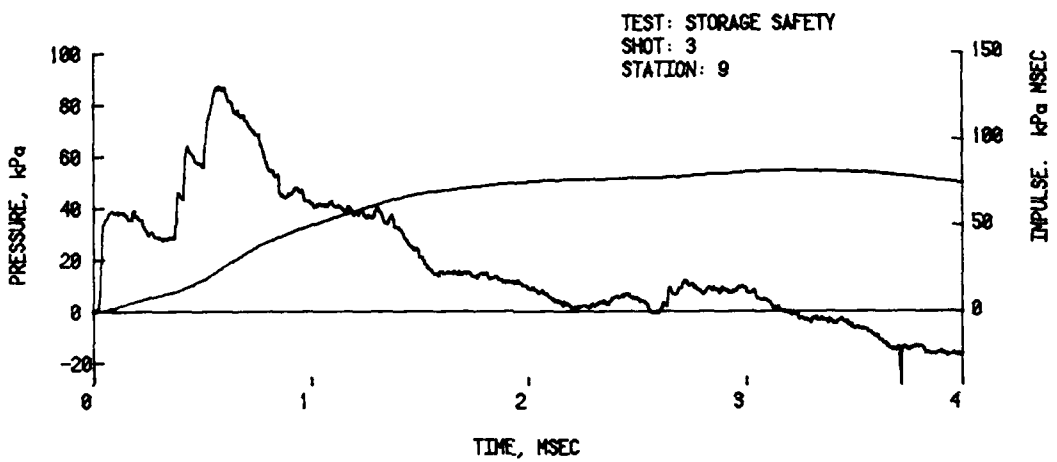
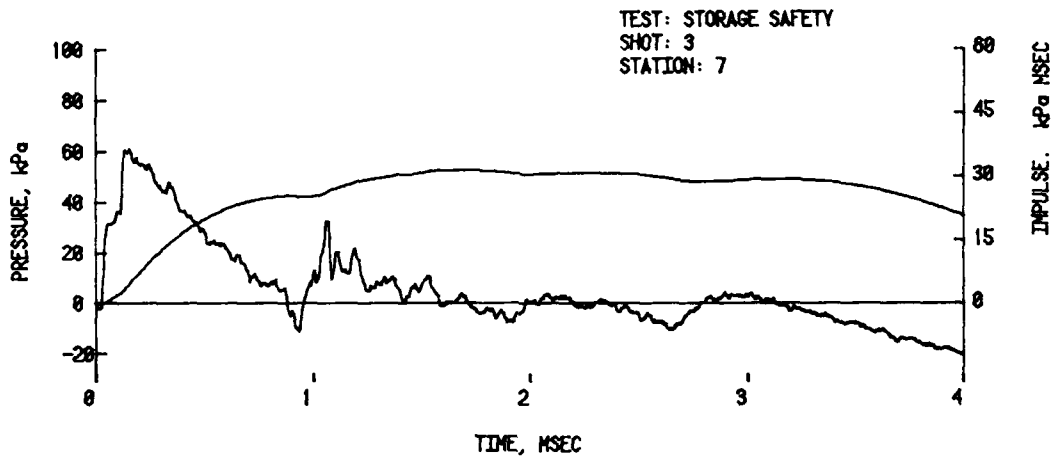

D. Far Side-Wall

Figure A-3. (Cont.)

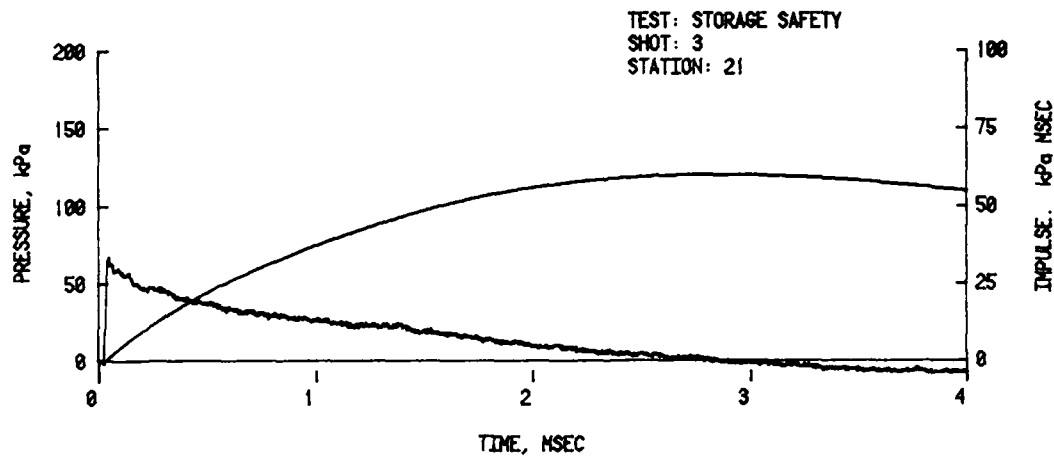
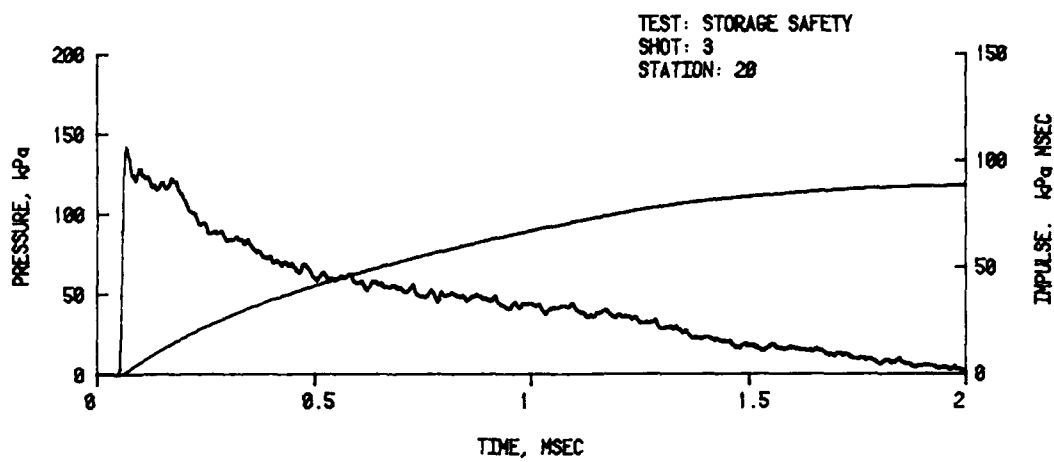
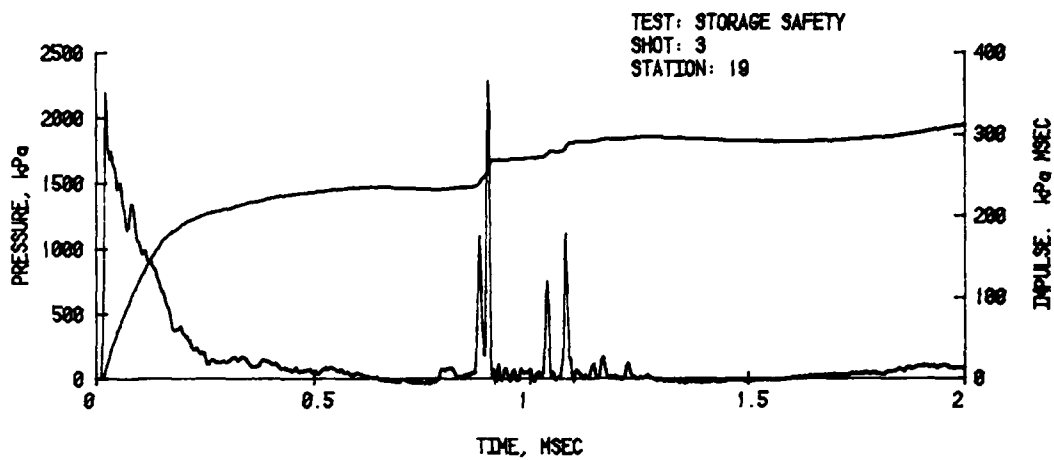

E. Free-Field

Figure A-3. (Cont.)

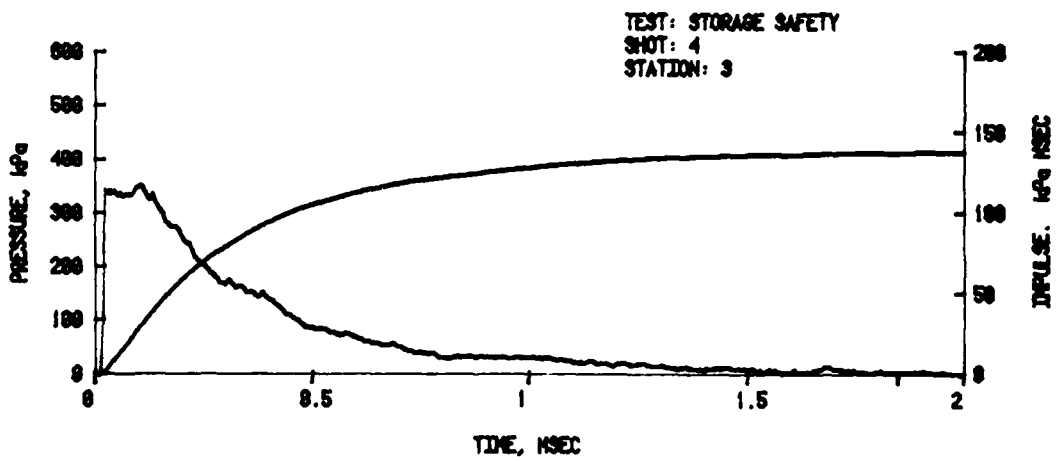
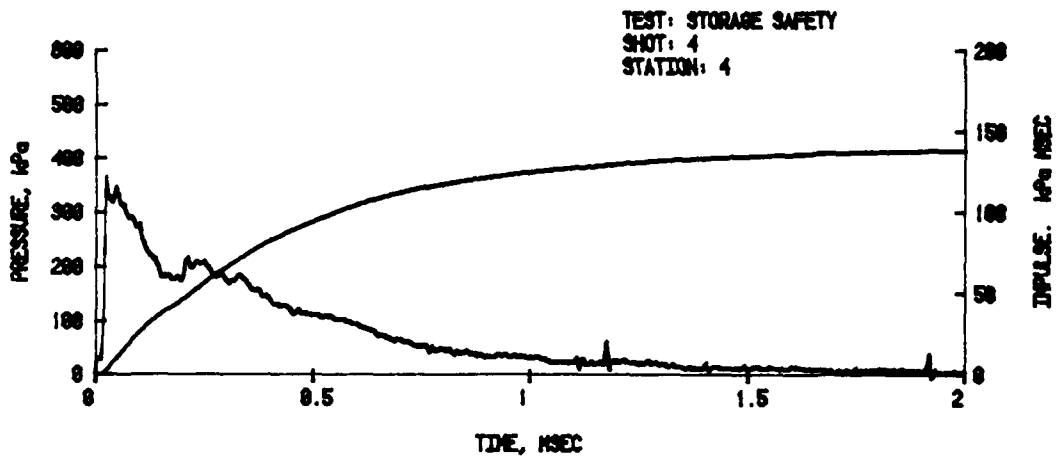
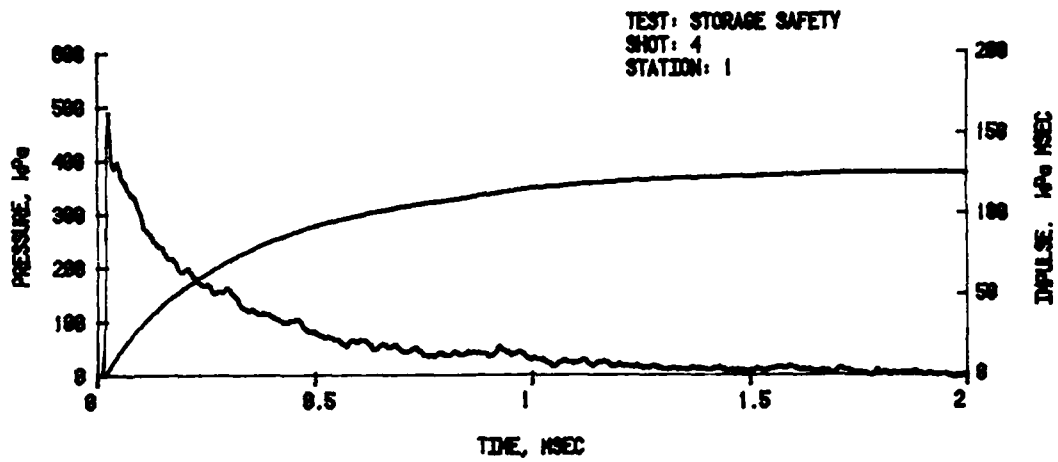

A. Near Side-Wall

Figure A-4. Pressure-Time Records for Shot 4,
Separation Distance $2.4 Q^{1/3}$ m

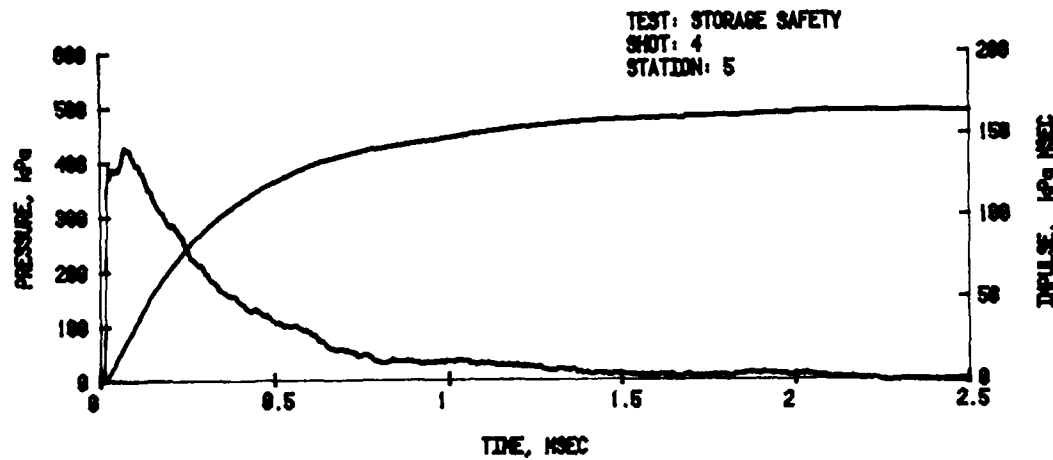
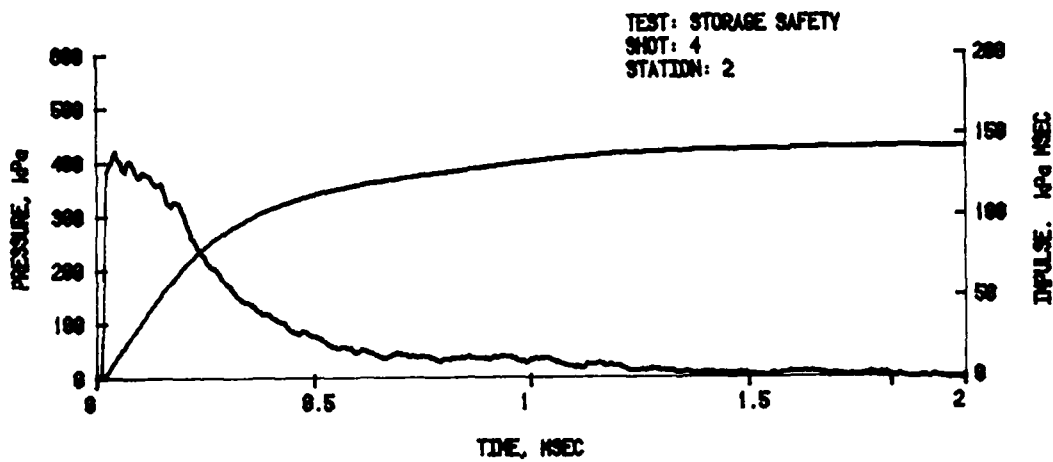
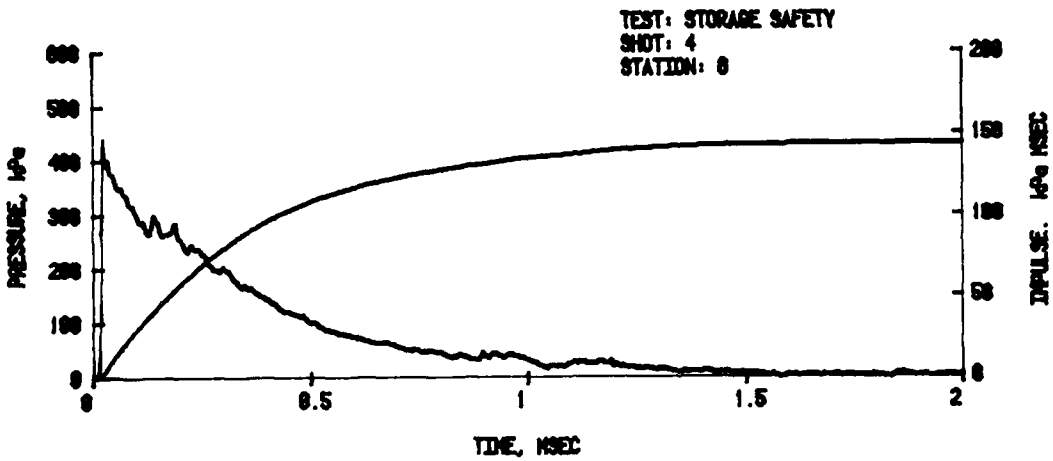

A. Near Side-Wall (Cont.)

Figure A-4. (Cont.)

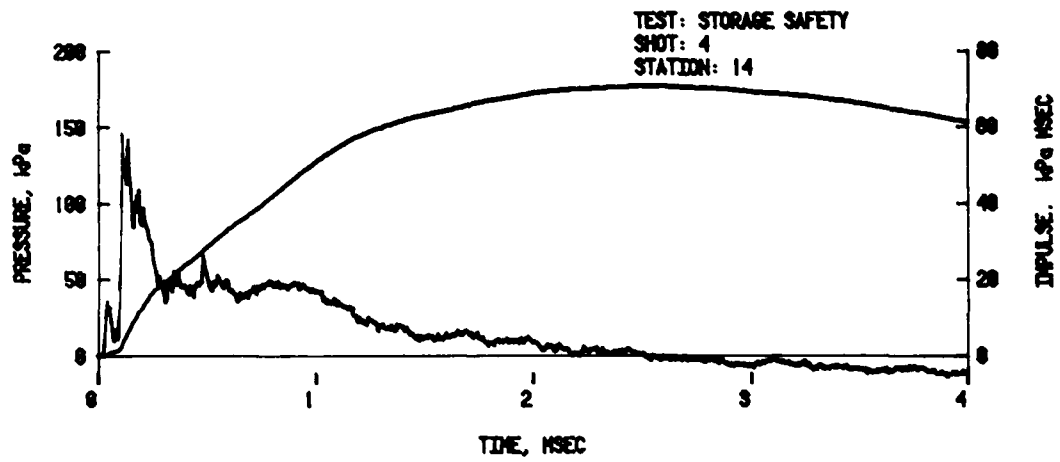
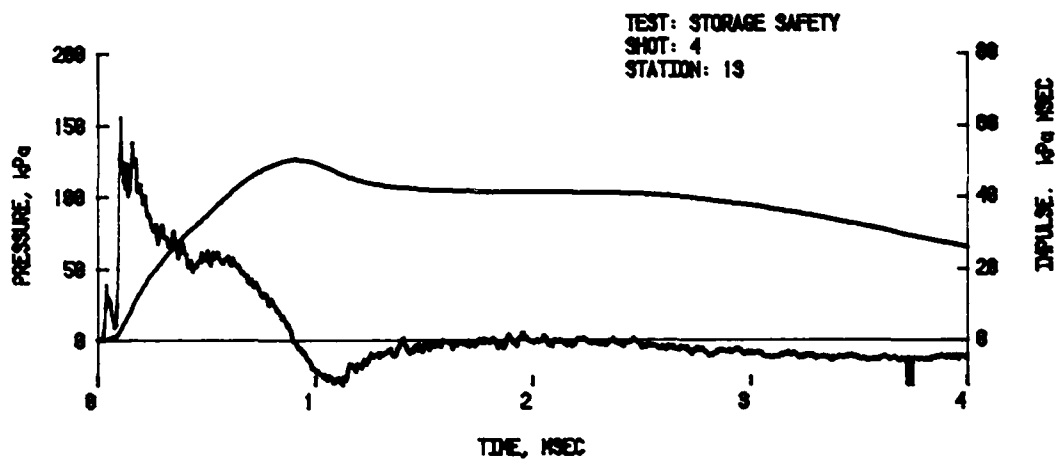
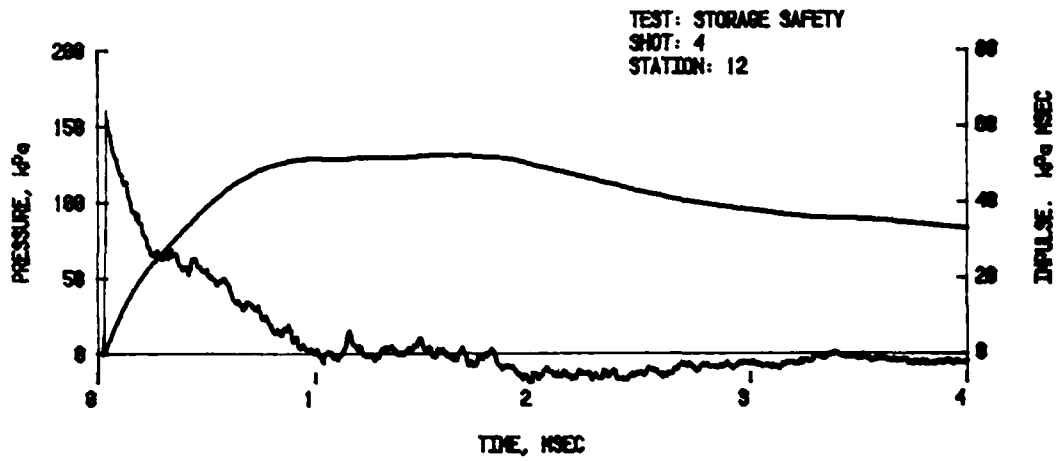

B. Roof

Figure A-4. (Cont.)

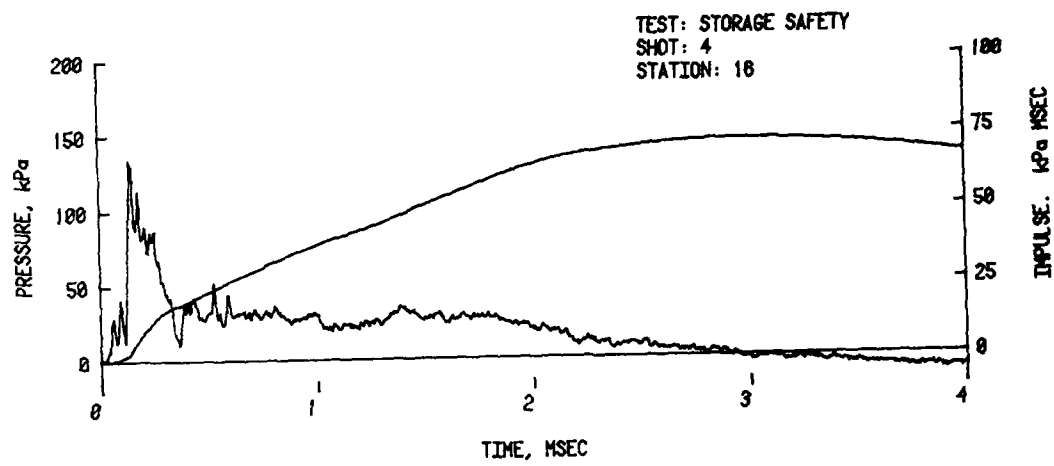
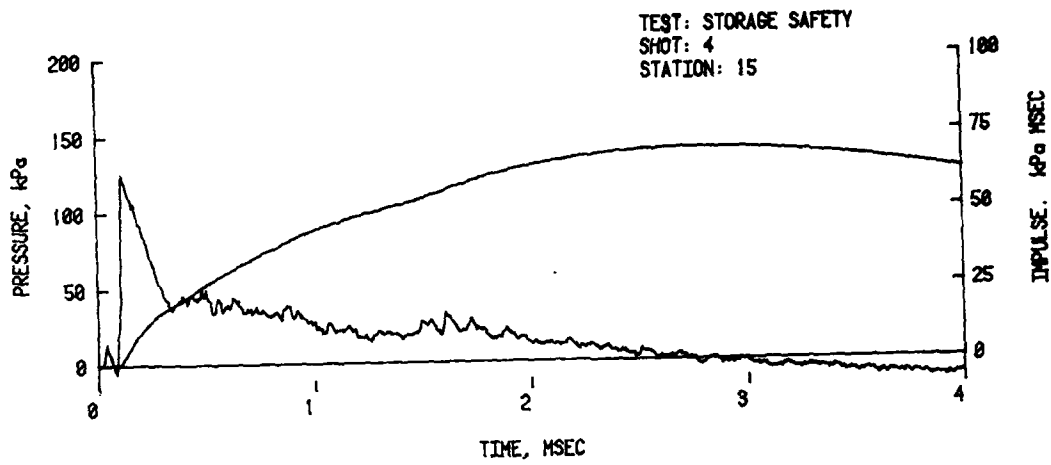

B. Roof (Cont.)

Figure A-4. (Cont.)

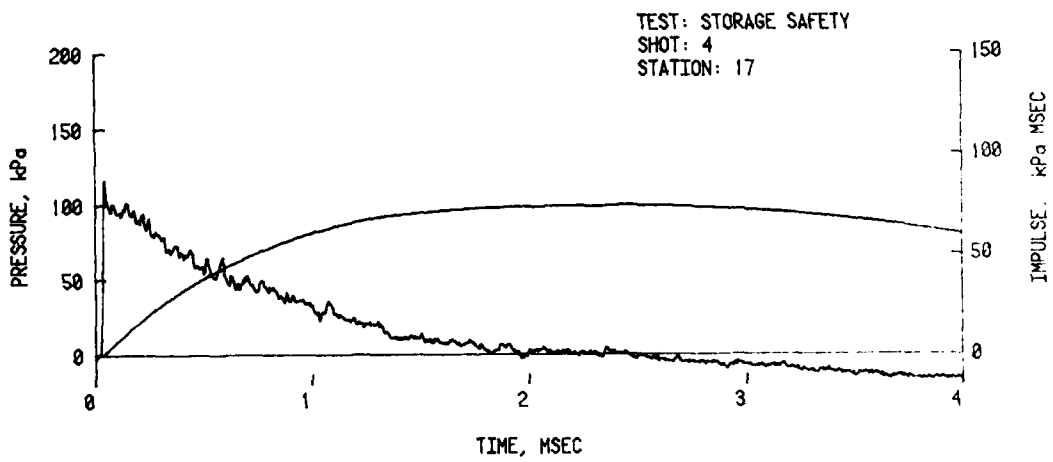
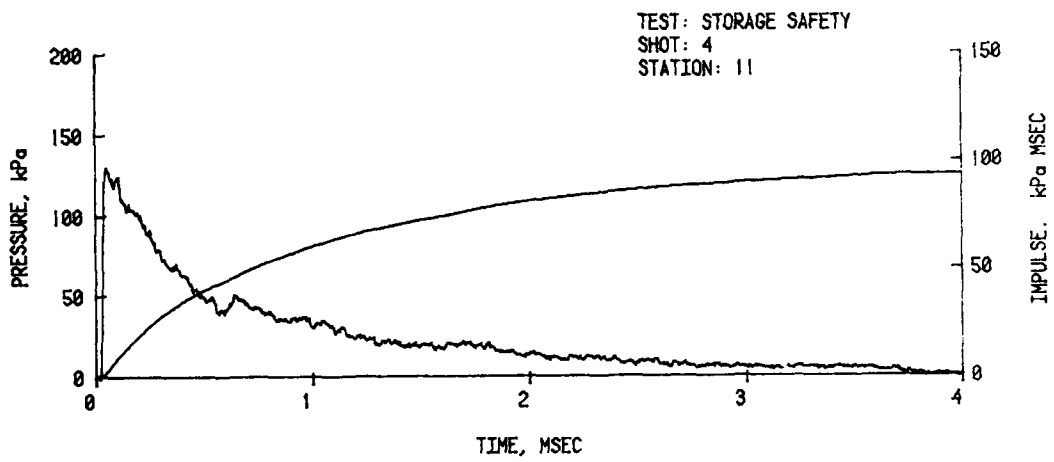
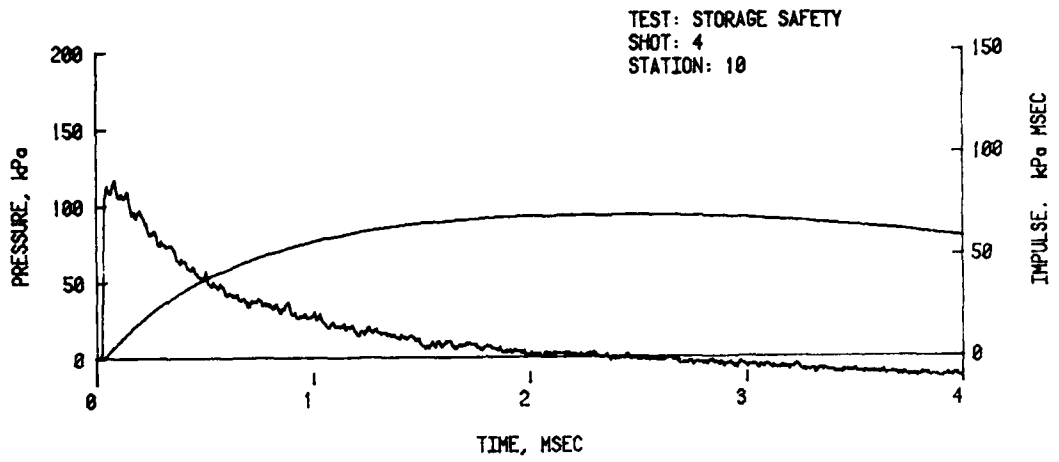

C. End Walls

Figure A-4. (Cont.)

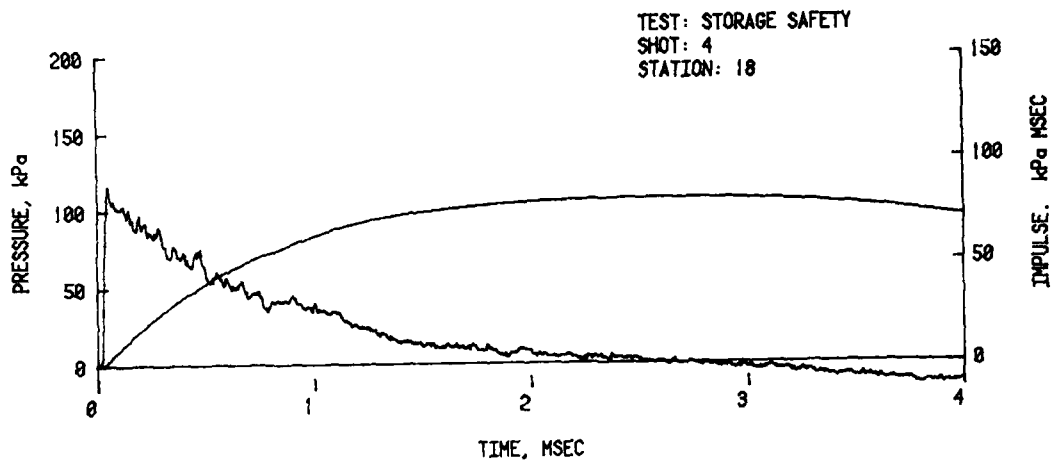

C. End Walls (Cont.)

Figure A-4. (Cont.)

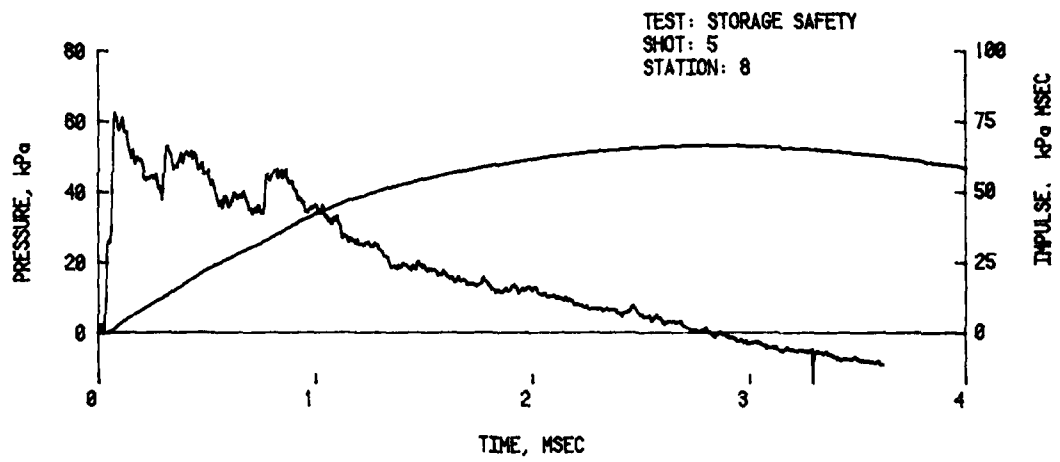
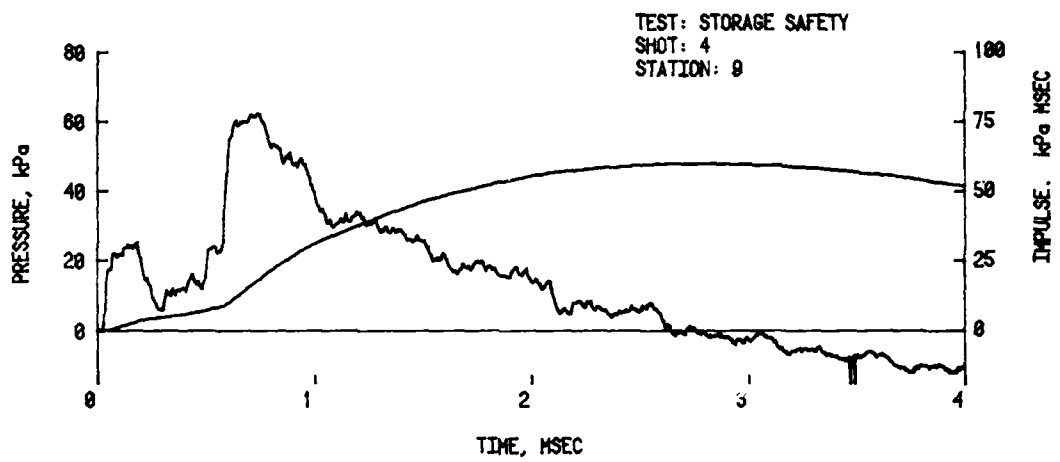
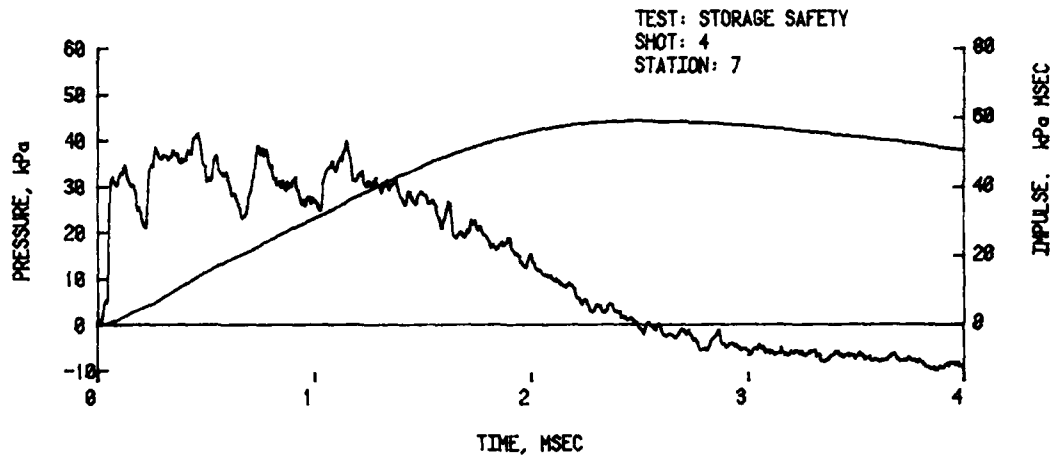

D. Far Side-Wall

Figure A -4. (Cont.)

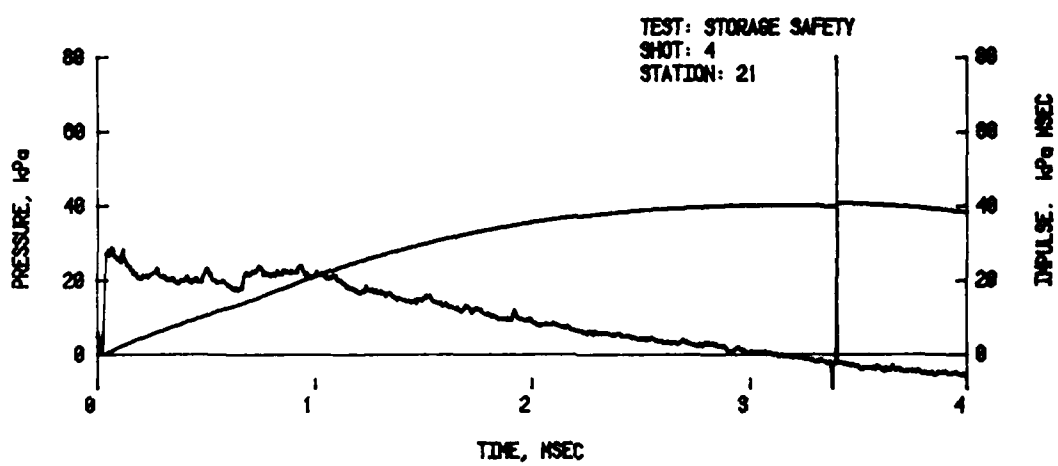
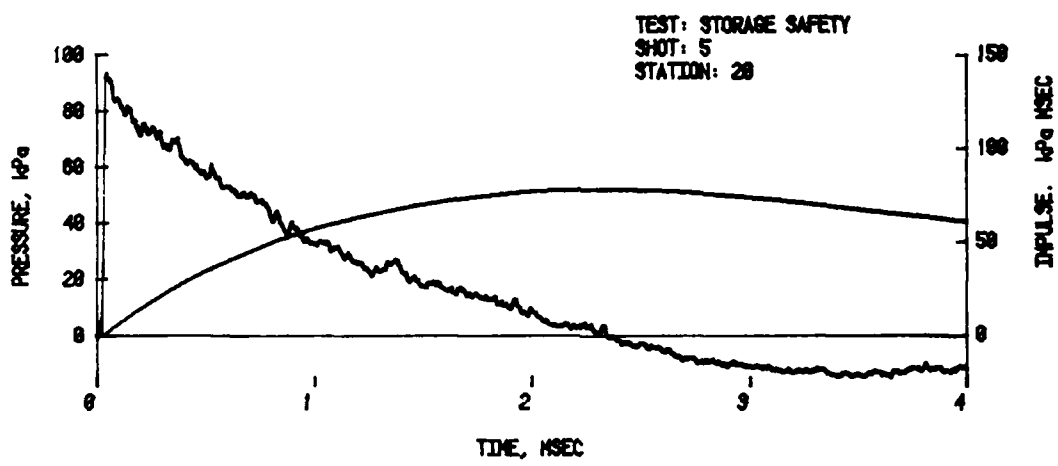
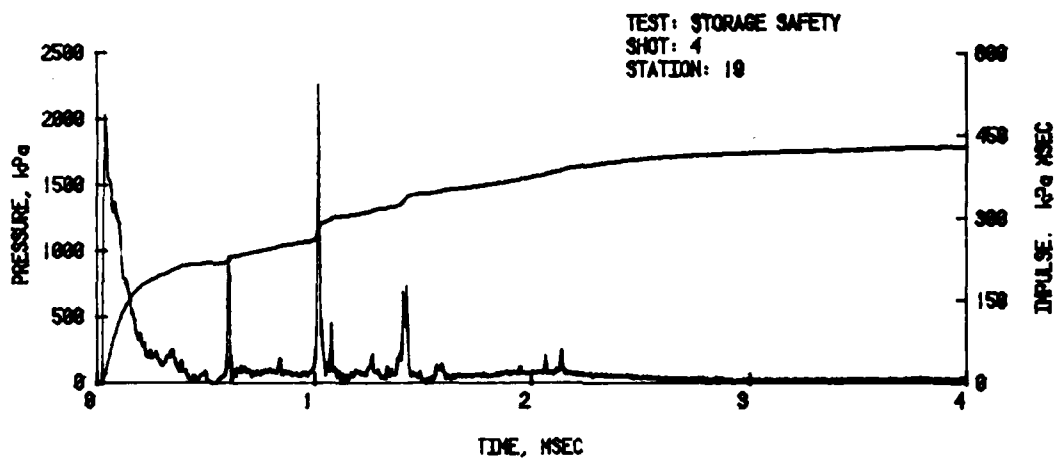

E. Free-Field

Figure A-4. (Cont.)

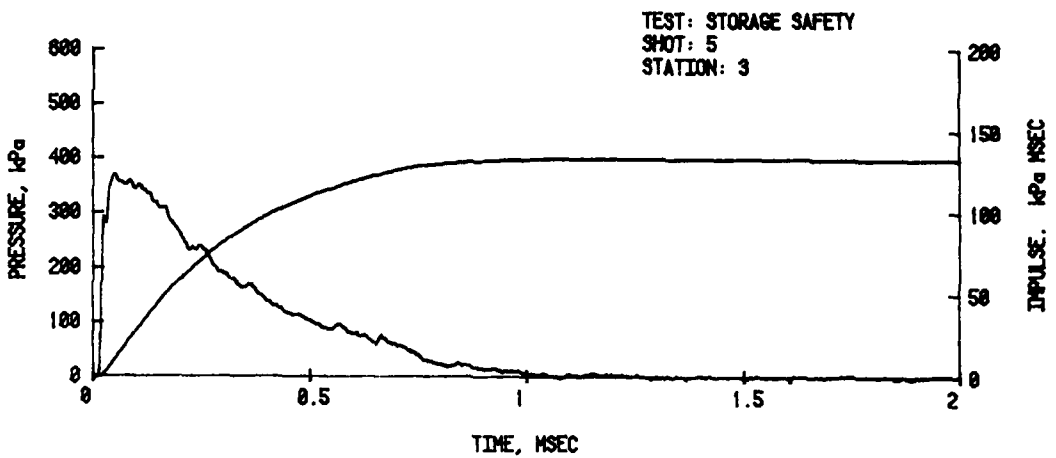
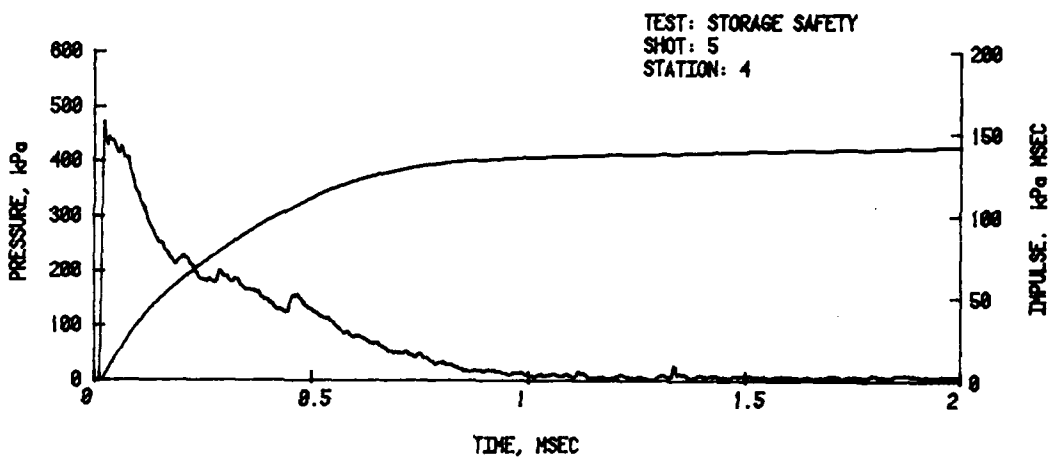
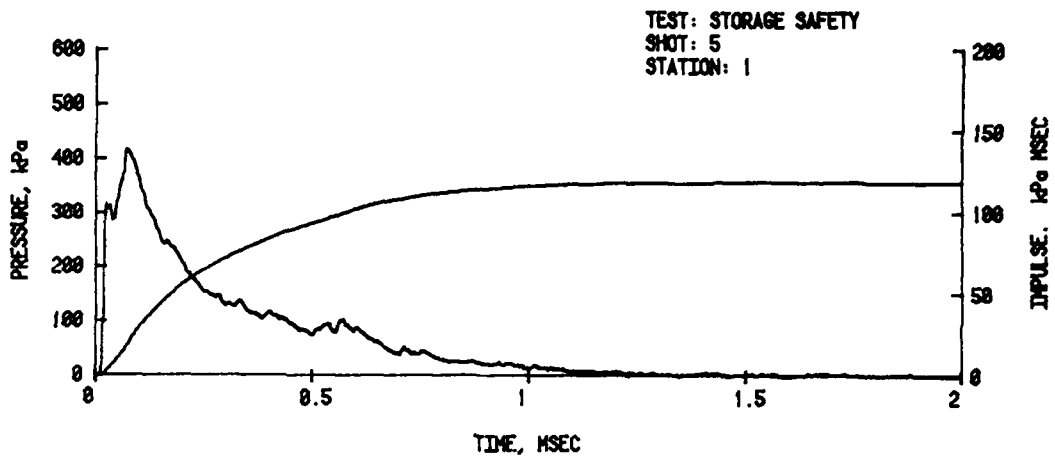

A. Near Side-Wall

Figure A-5. Pressure-Time Records for Shot 5,
Separation Distance $2.4 Q^{1/3}$ m

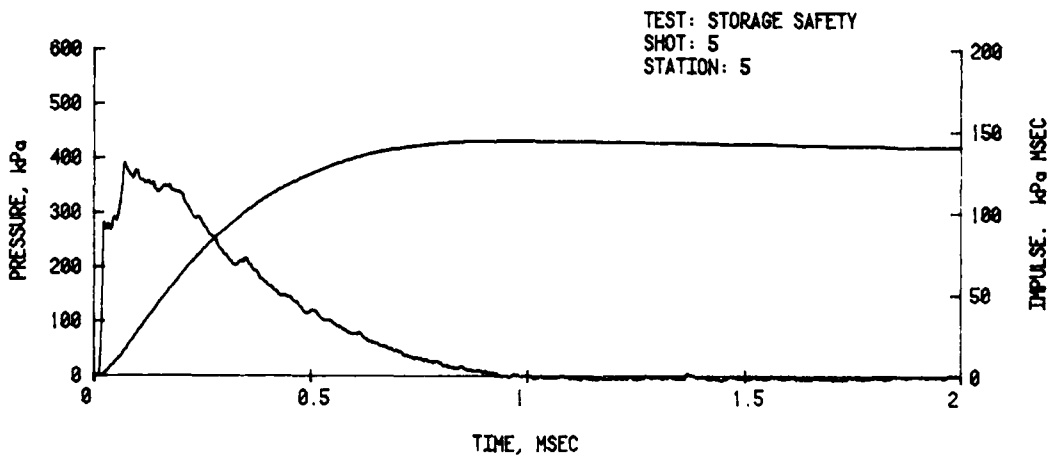
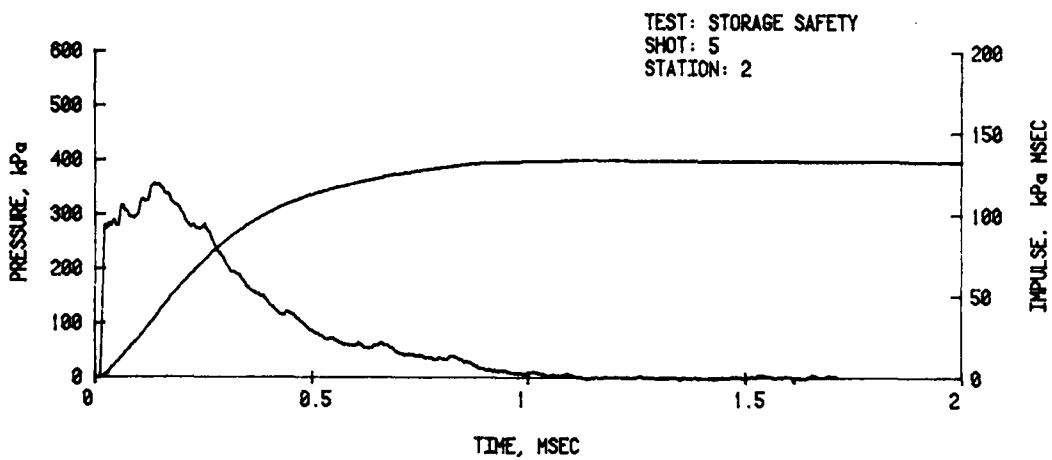
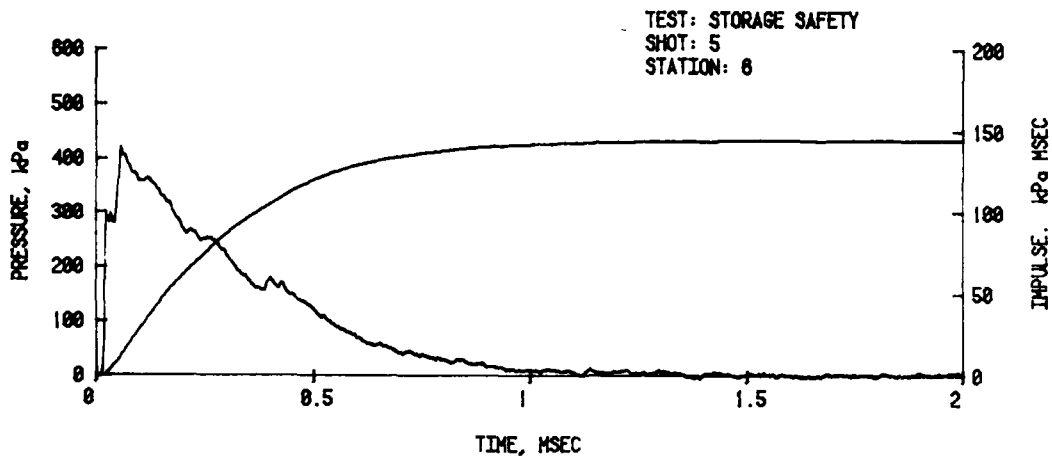

A. Near Side-Wall (Cont.)

Figure A-5. (Cont.)

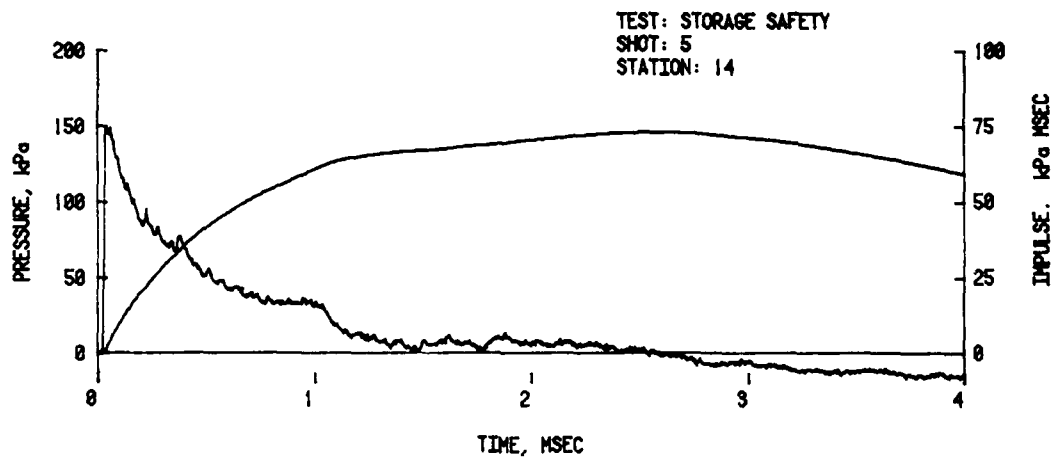
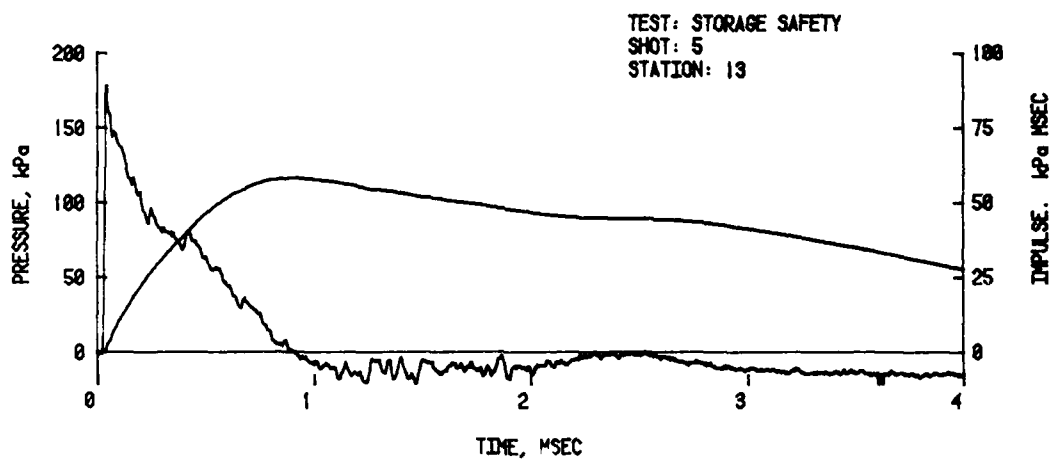
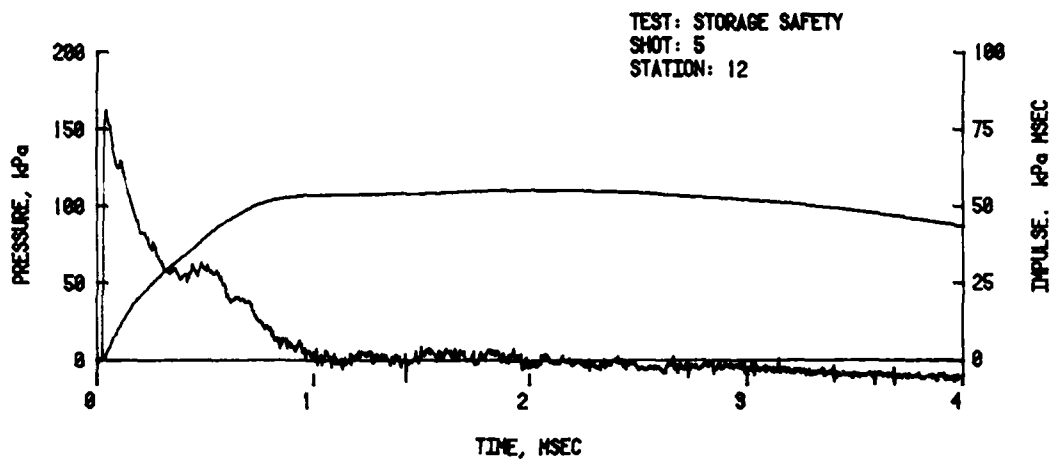

B. Roof

Figure A-5. (Cont.)

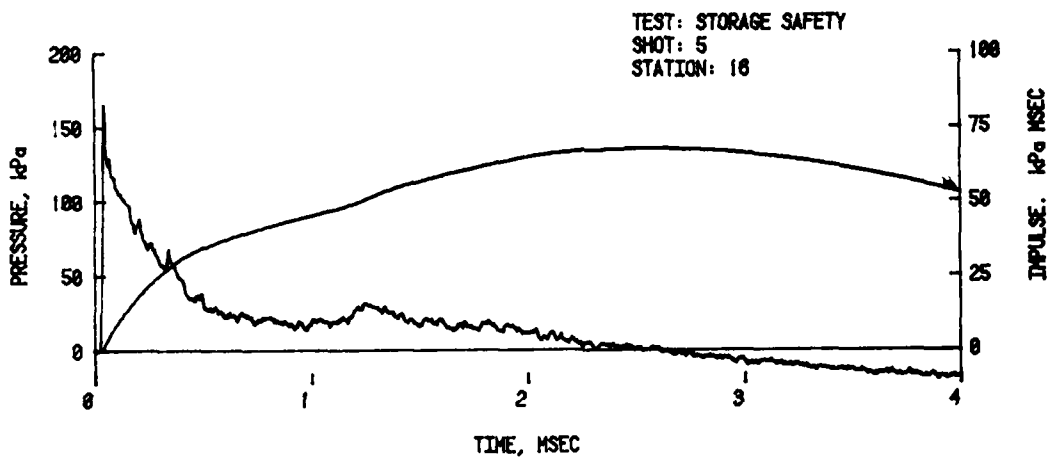
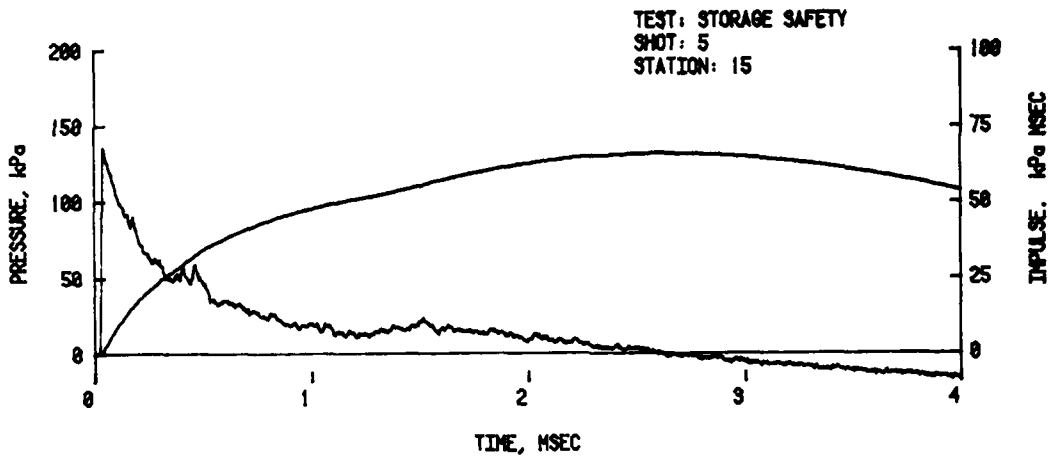

B. Roof (Cont.)

Figure A-5. (Cont.)

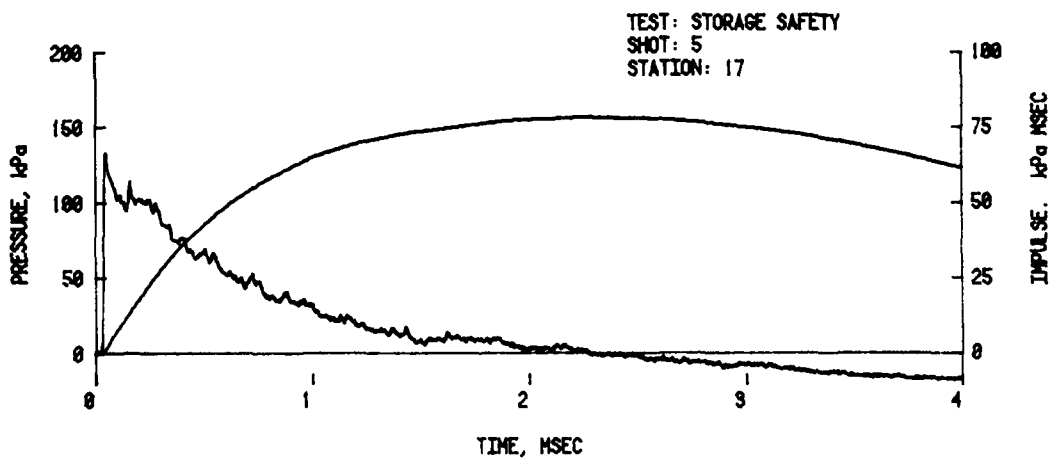
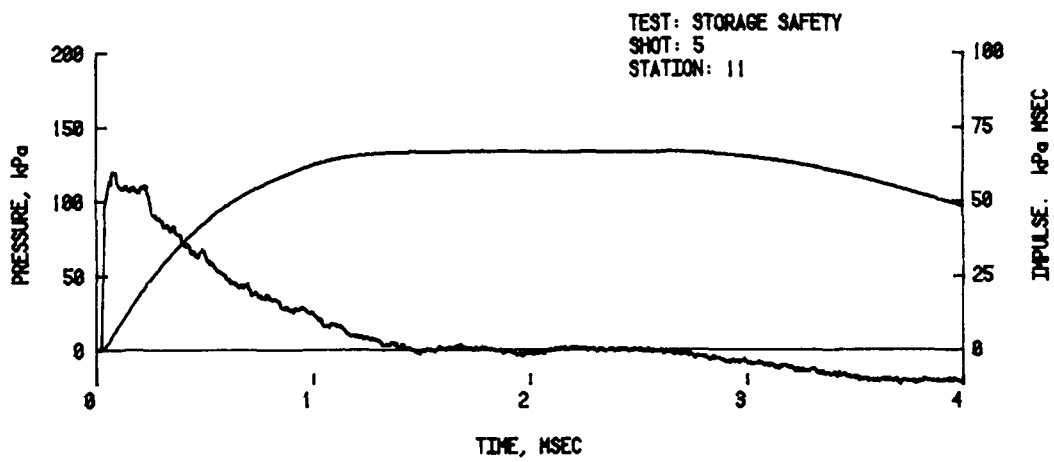
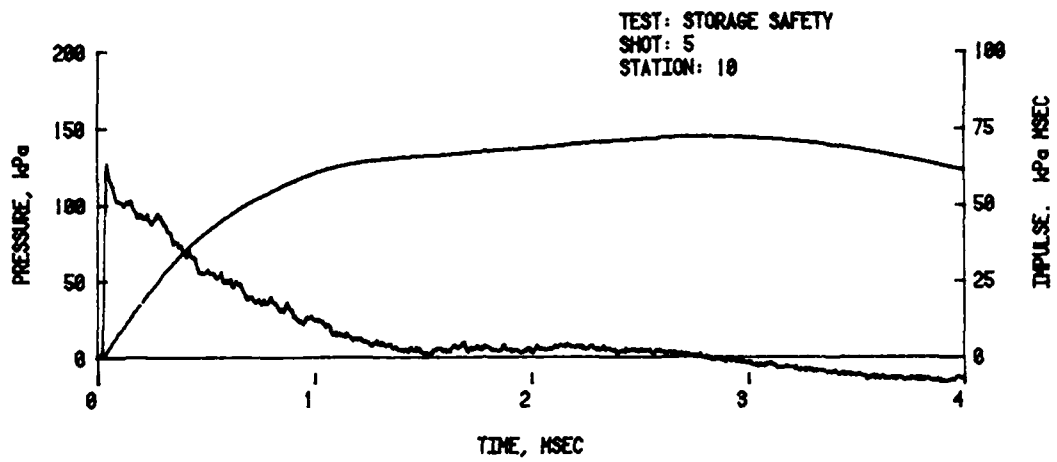

C. End Walls

Figure A-5. (Cont.)

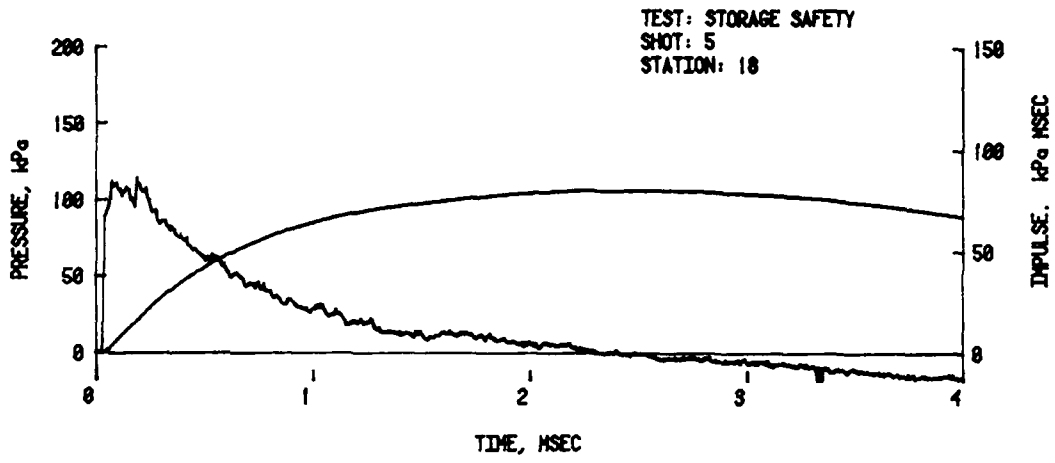

C. End Walls (Cont.)

Figure A-5. (Cont.)

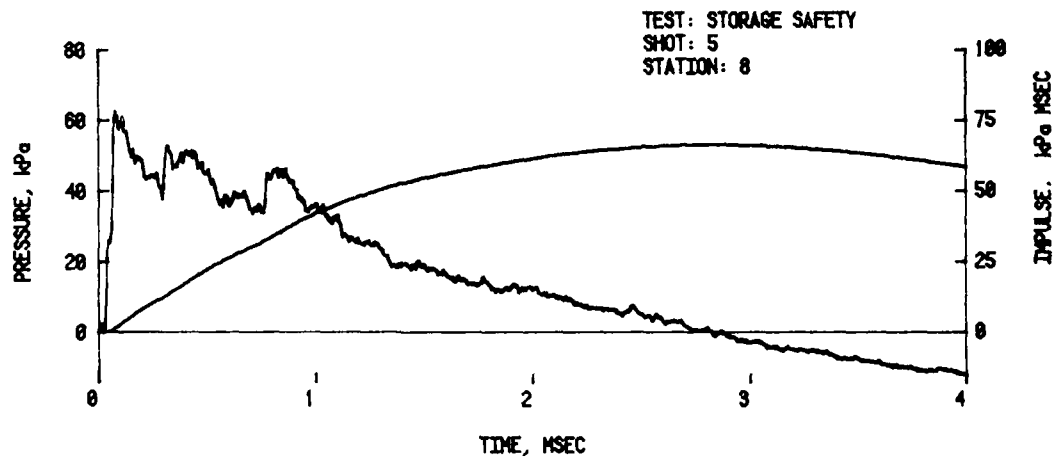
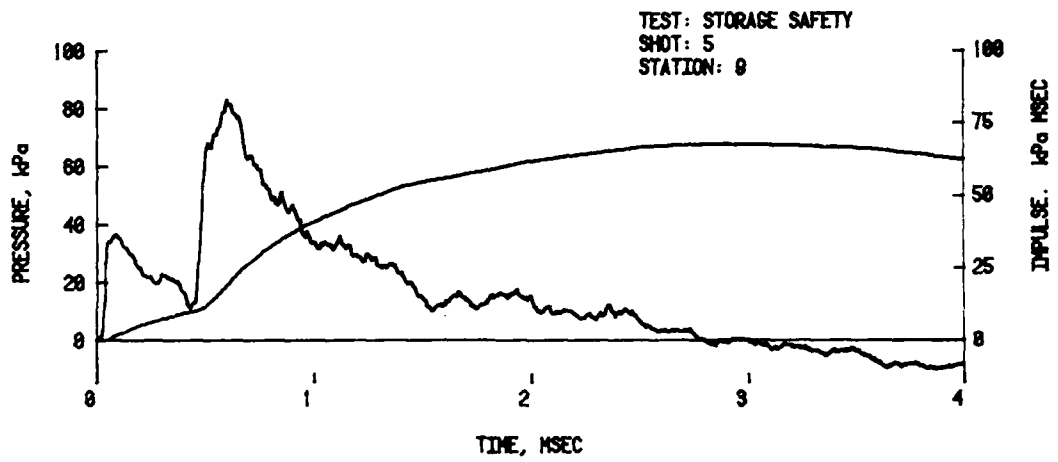
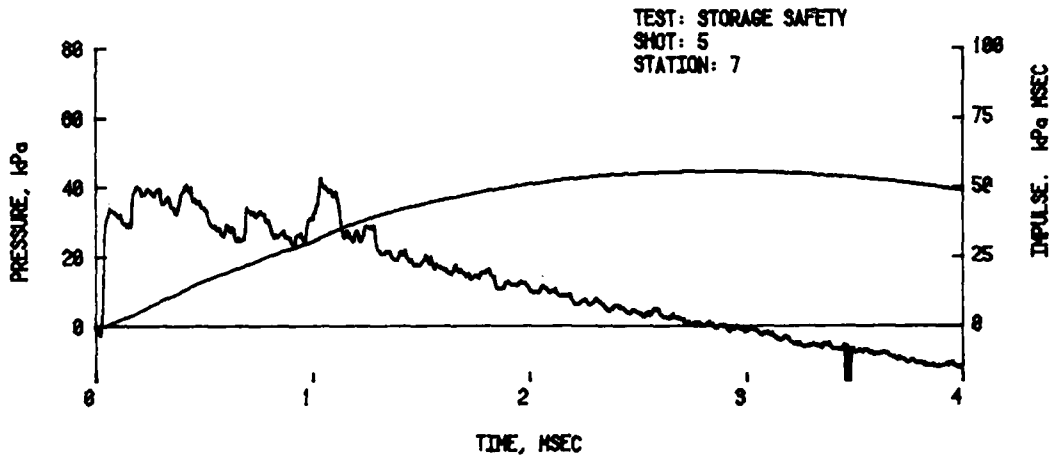

D. Far Side-Wall

Figure A-5. (Cont.)

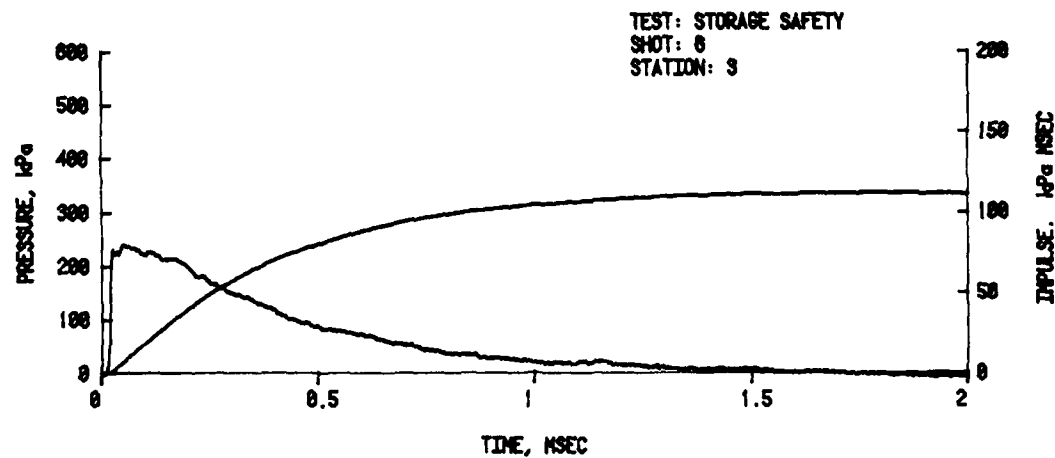
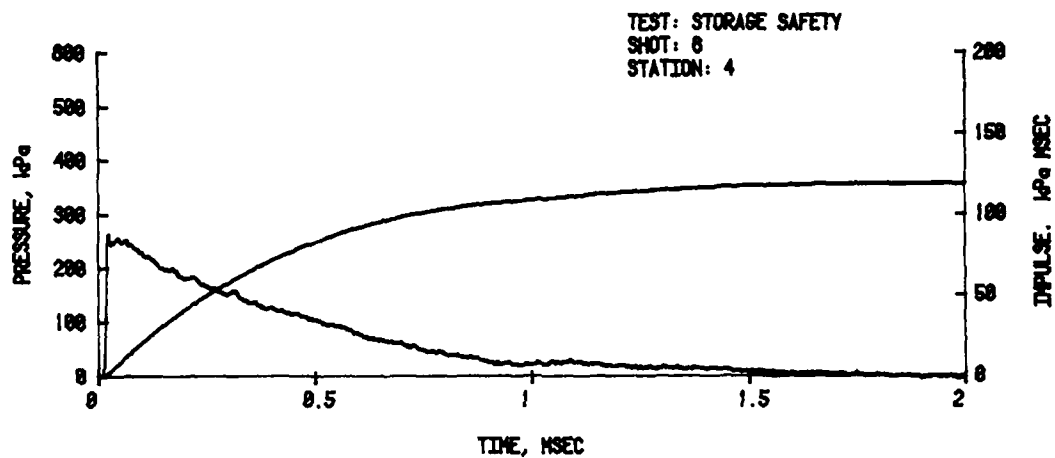
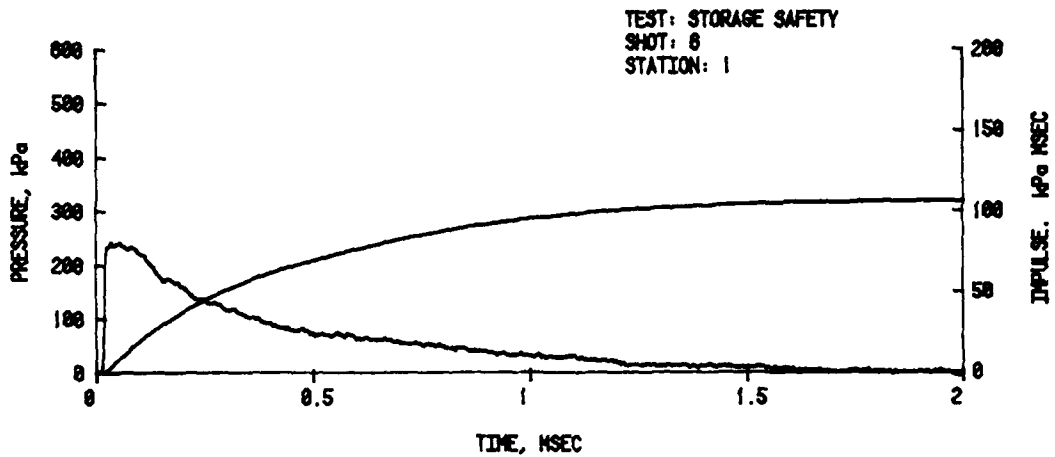

A. Near Side-Wall

Figure A-6. Pressure-Time Records for Shot 6,
Separation Distance $2.4 Q^{1/3}$ m

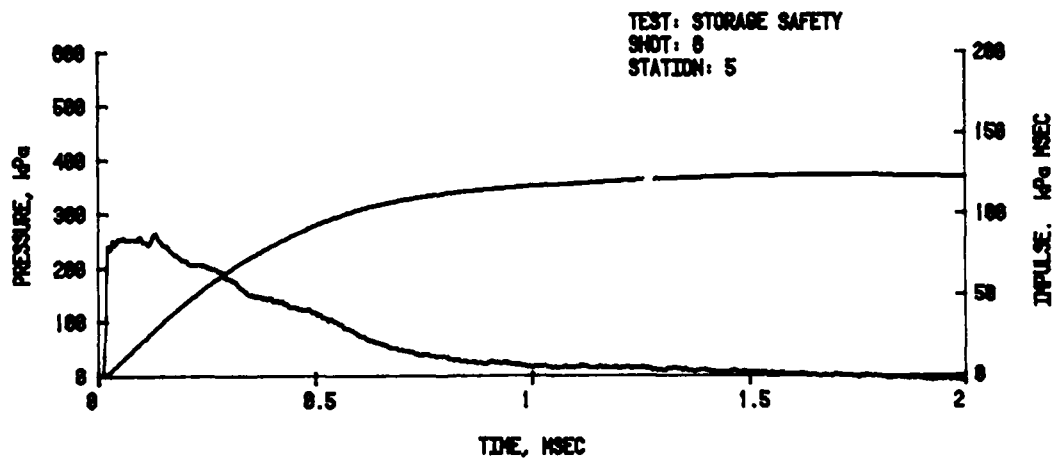
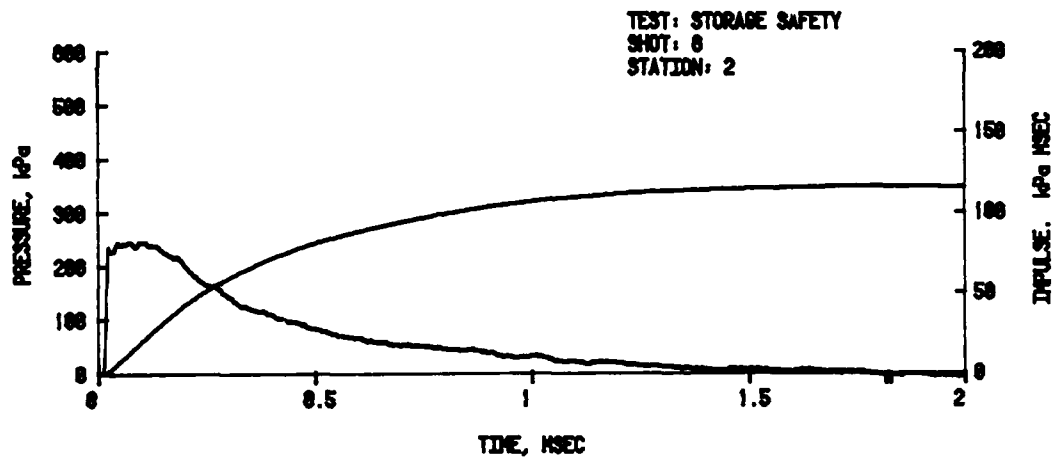
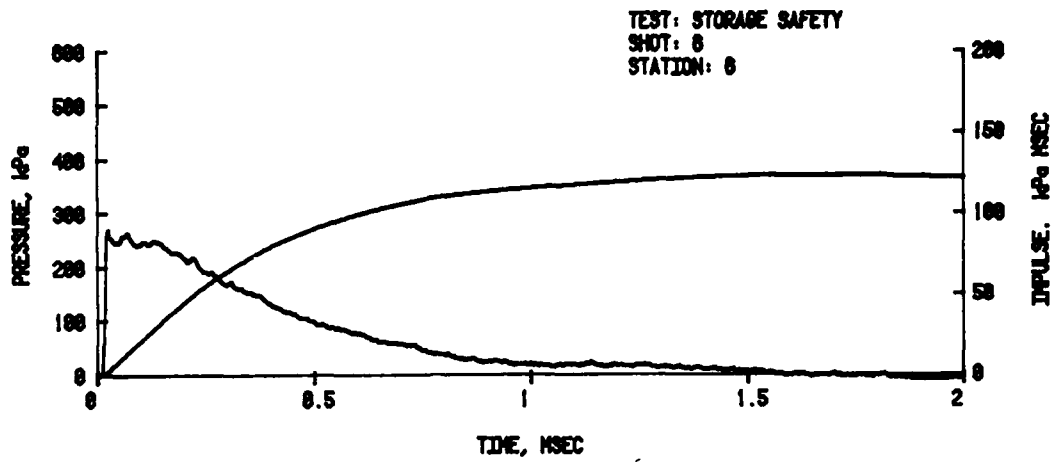

A. Near Side-Wall (Cont.)

Figure A-6. (Cont.)

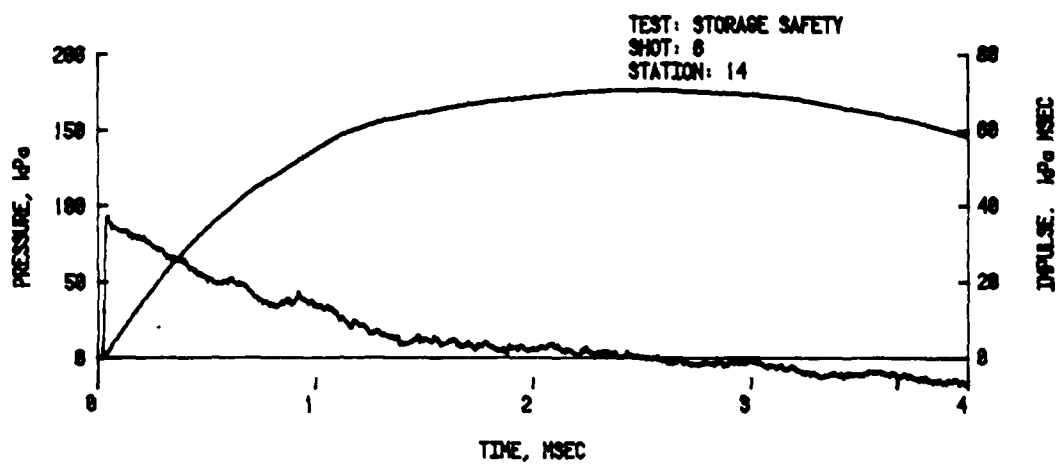
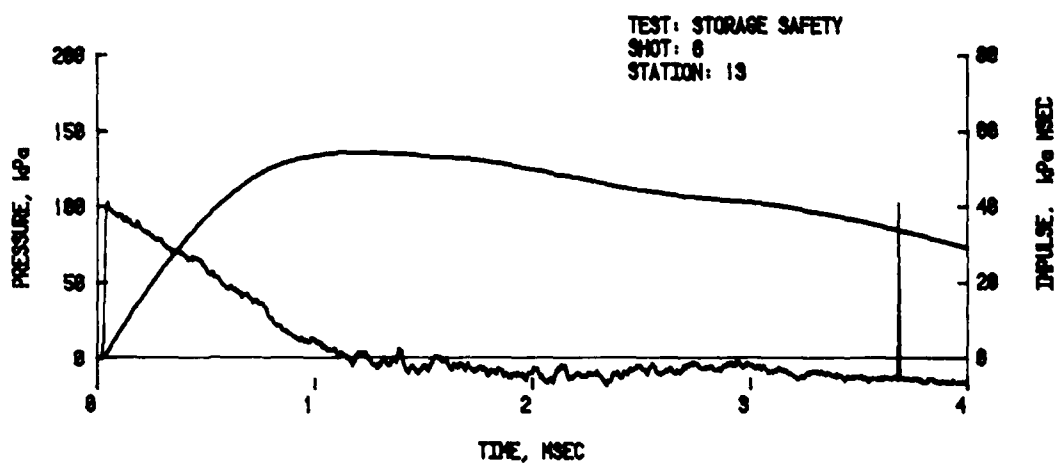
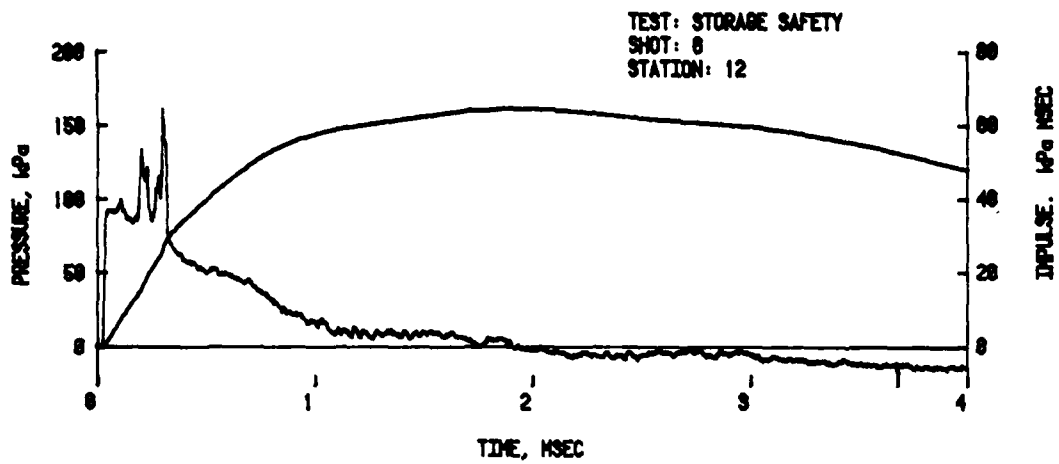

B. Roof

Figure A-6. (Cont.)

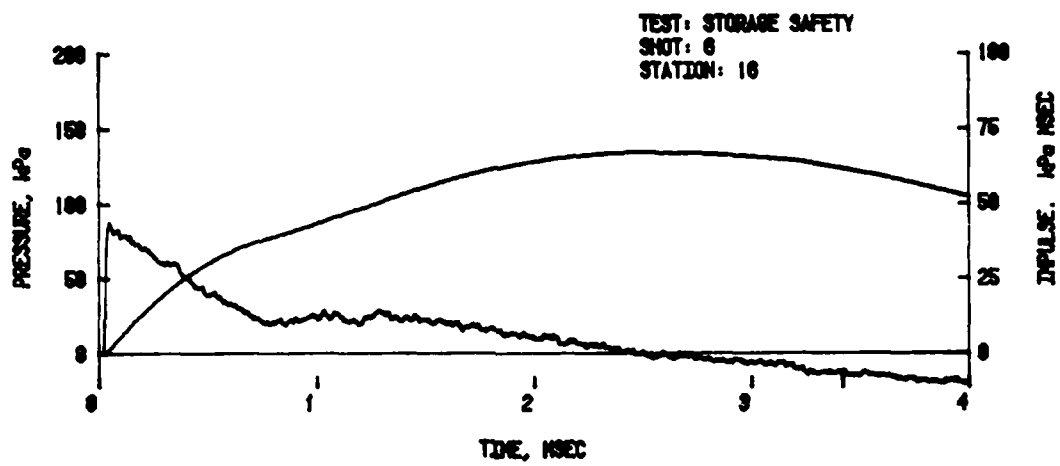
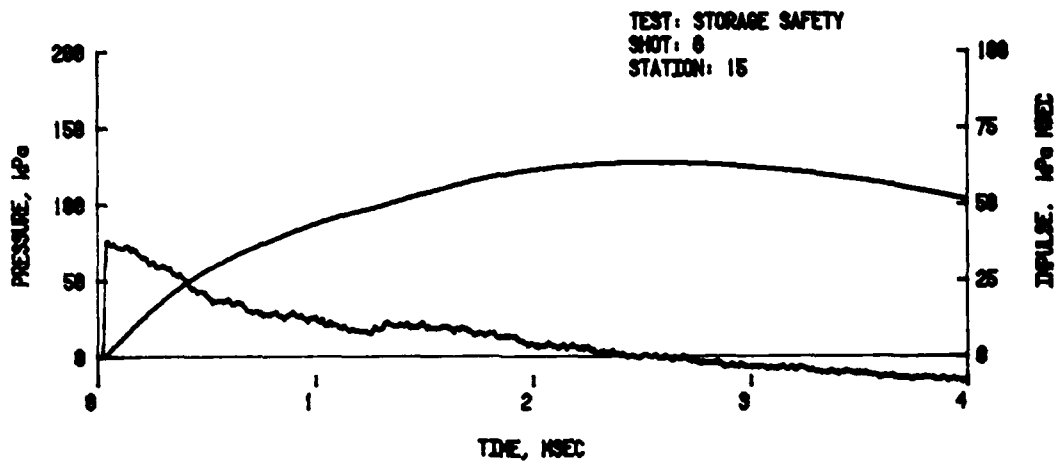

B. Roof (Cont.)

Figure A-6. (Cont.)

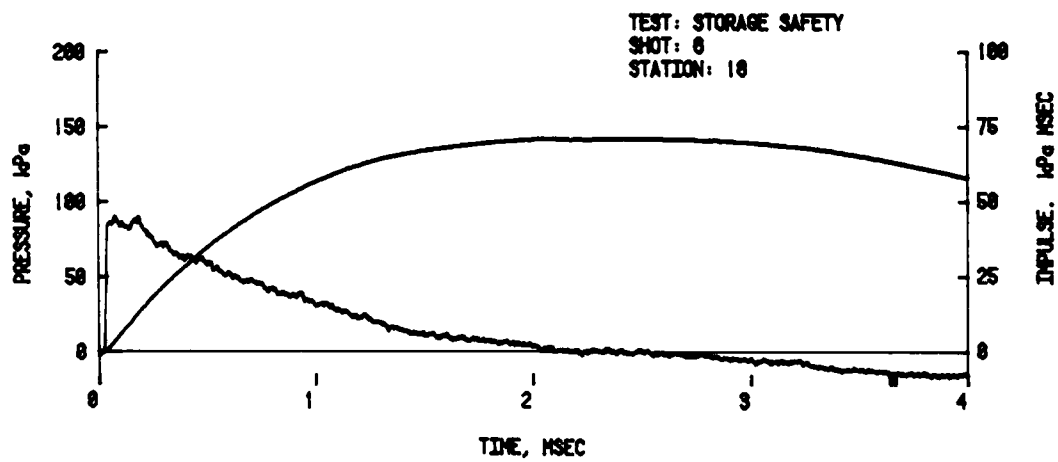
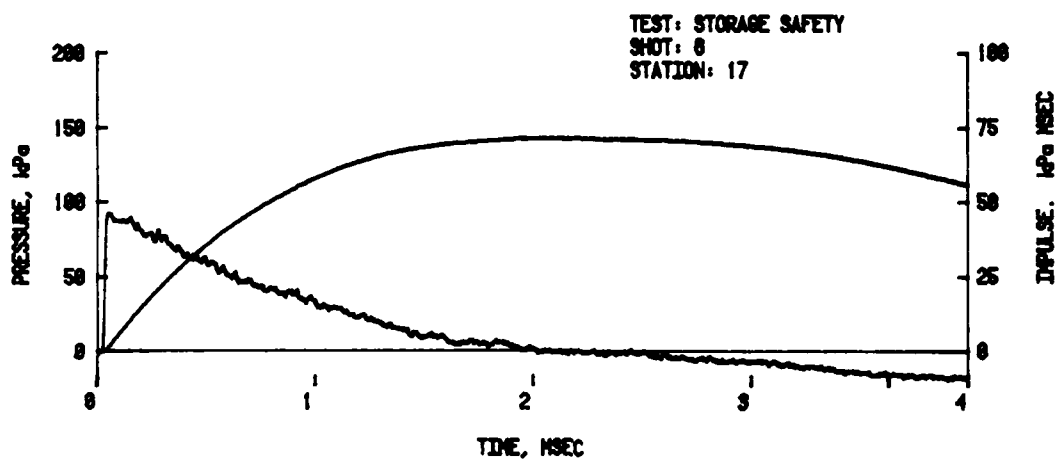
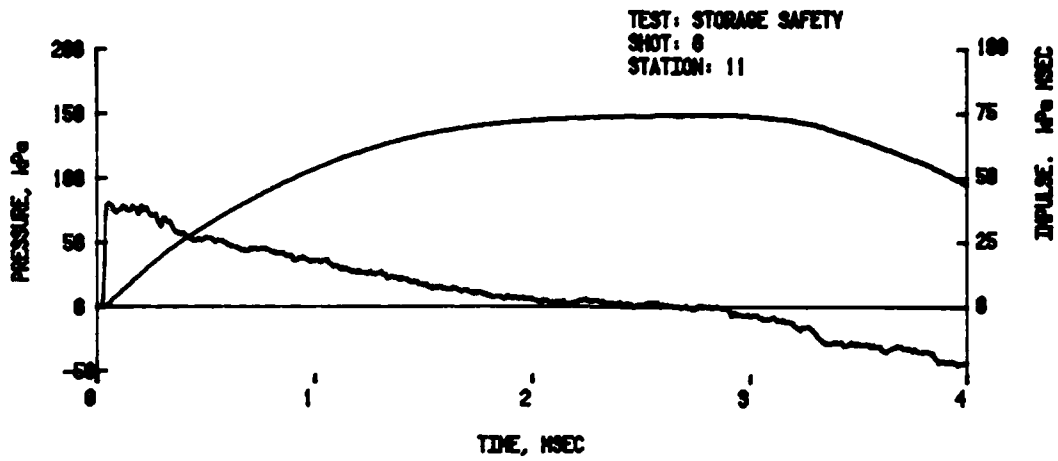

C. End Walls

Figure A-6. (Cont.)

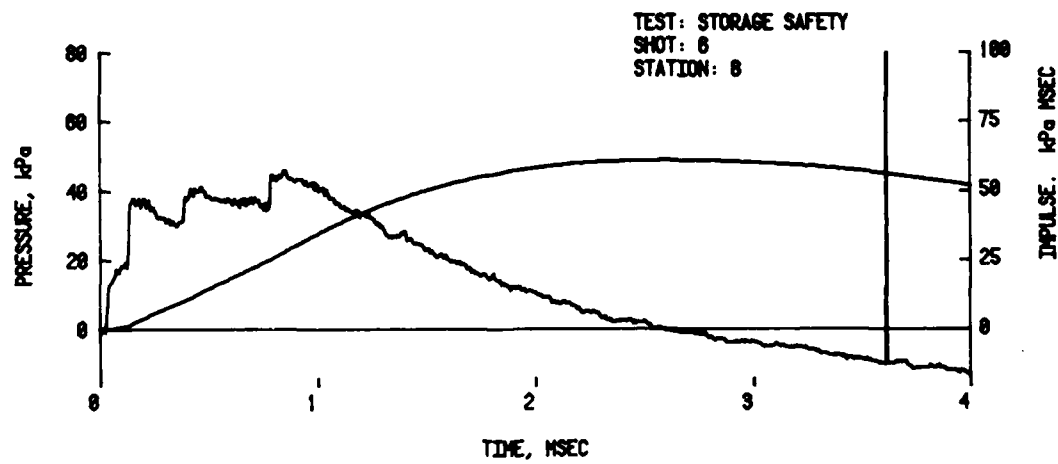
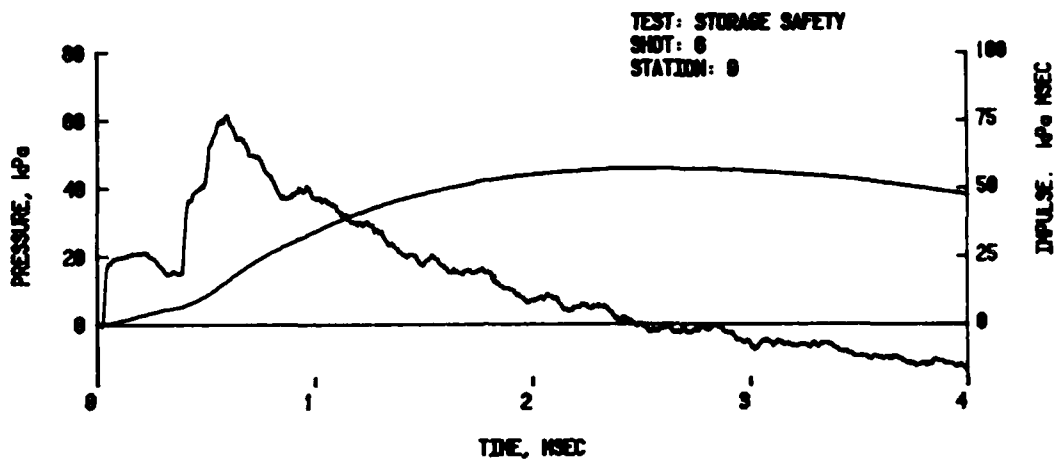
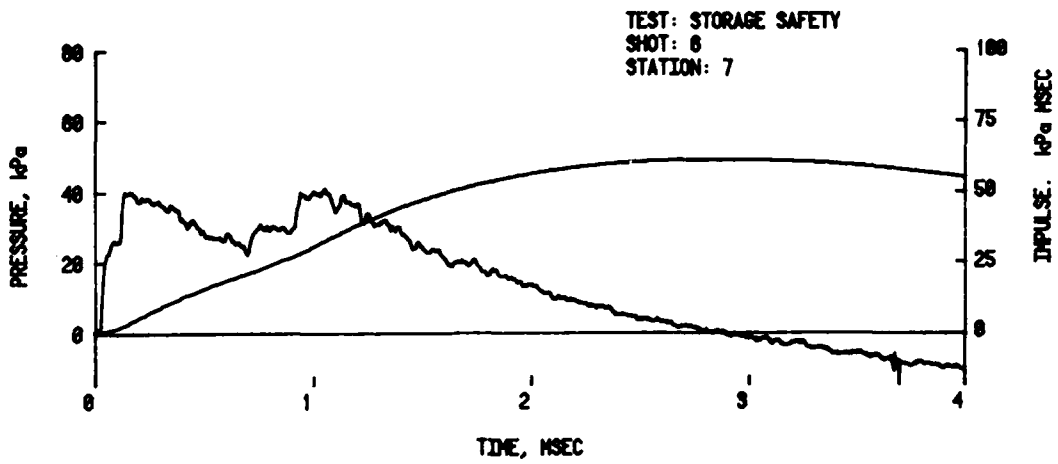

D. Far Side-Wall

Figure A-6. (Cont)

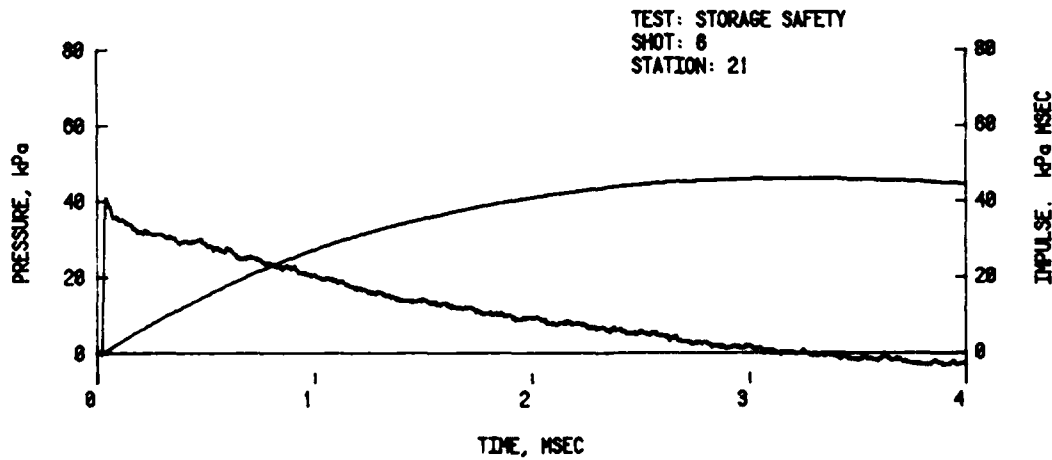
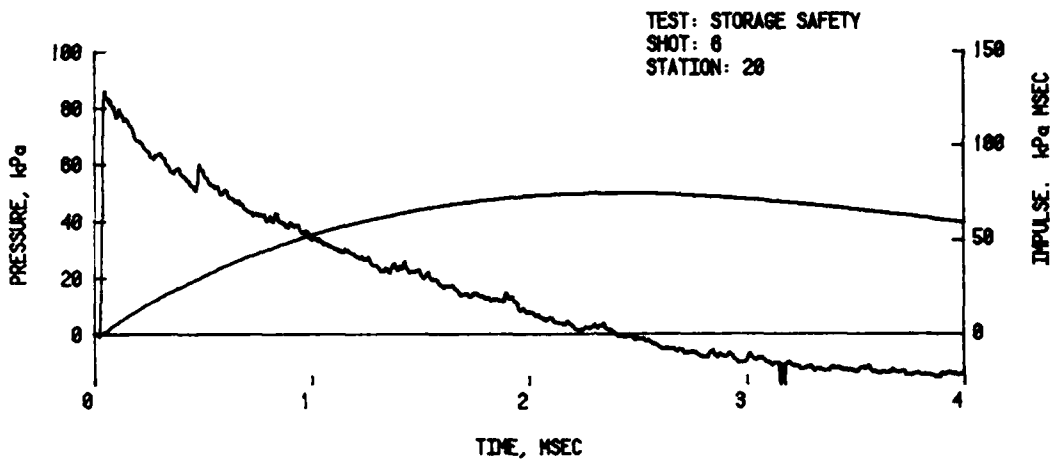
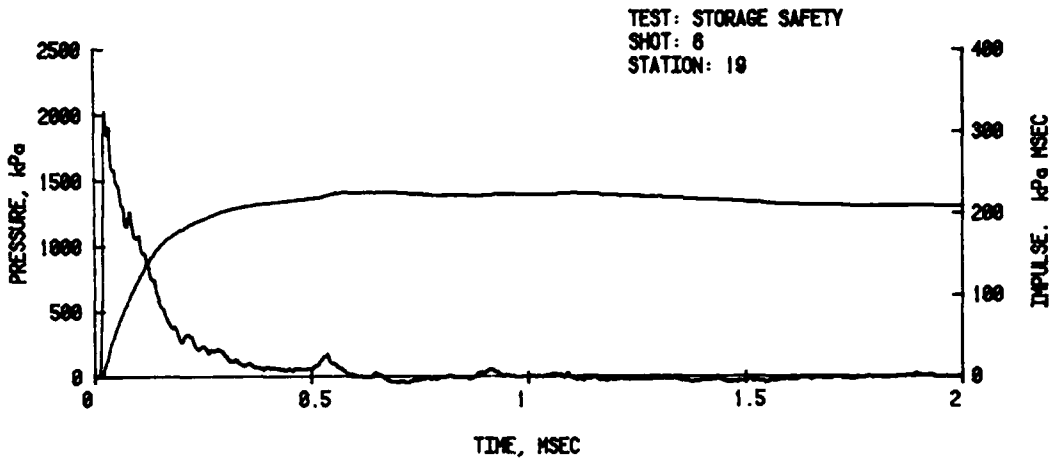

E. Free-Field

Figure A-6. (Cont.)

DISTRIBUTION LIST

<u>No. of Copies</u>	<u>Organization</u>	<u>No. of Copies</u>	<u>Organization</u>
12	Administrator Defense Technical Info Center ATTN: DTIC-DDA Cameron Station Alexandria, VA 22304-6145	1	Director US Army Air Mobility Research and Development Laboratory Ames Research Center Moffett Field, CA 94035
1	HQDA DAMA-ART-M Washington, DC 20310	1	Commander US Army Communications - Electronics Command ATTN: AMSEL-ED Fort Monmouth, NJ 07703
1	Commander US Army Materiel Command ATTN: AMCDRA-ST 5001 Eisenhower Avenue Alexandria, VA 22333-0001	1	Commander ERADCOM Technical Library ATTN: DELSD-L (Reports Section) Fort Monmouth, NJ 07703-5301
1	Commander Armament R&D Center US Army AMCCOM ATTN: SMCAR-ISS Dover, NJ 07801	1	Commander MICOM Research, Development & Engineering Center ATTN: AMSMI-RD Redstone Arsenal, AL 35898
2	Commander Armament R&D Center US Army AMCCOM ATTN: SMCAR-TDC SMCAR-LCM-SPC Dover, NJ 07801	1	Director Missile & Space Intelligence Center ATTN: AIAM-S-YDL Redstone Arsenal, AL 35898-5500
1	Director Benet Weapons Laboratory Armament R&D Center US Army AMCCOM ATTN: SMCAR-LCB-TL Watervliet, NY 12189	1	Commander US Army Tank Automotive Command ATTN: AMSTA-TSL Warren, MI 48090
1	Commander US Army Armament, Munitions and Chemical Command ATTN: SMCAR-ESP-L Rock Island, IL 61299	1	Director US Army TRADOC System Analysis Activity ATTN: ATAA-SL White Sands Missile Range, NM 88002
1	Commander US Army Aviation Research and Development Command ATTN: AMSAV-E 4300 Goodfellow Blvd St. Louis, MO 63120	1	Director Defense Intelligence Agency ATTN: DI-18, Dr. J. Vorona Washington, DC 20301

DISTRIBUTION LIST

<u>No. of Copies</u>	<u>Organization</u>	<u>No. of Copies</u>	<u>Organization</u>
1	Commandant US Army Infantry School ATTN: ATSH-CD-CSO-OR Fort Benning, GA 31905	29	Chairman Department of Defense Explosives Safety Board 2461 Eisenhower Avenue Alexandria, VA 22331
1	Commander US Army Development and Employment Agency ATTN: MODE-TEO-SAR Fort Lewis, WA 98433	3	Director Institute for Defense Analyses ATTN: Dr. H. Menkes Dr. J. Bengston Tech Info Ofc 1801 Beauregard St. Alexandria, VA 22311
1	AFWL/SUL Kirtland AFB, NM 87117		
1	Air Force Armament Laboratory ATTN: AFATL/DLODL Eglin AFB, FL 32542-5000	2	Chairman Joint Chiefs of Staff ATTN: J-3, Operations J-5, Plans & Policy (R&D Division) Washington, DC 20301
1	Office Secretary of Defense ADUSDRE (R/AT) (ET) ATTN: Mr. J. Persh, Staff Specialist, Materials and Structures Washington, DC 20301	1	Director Defense Communications Agency ATTN: NMCSSC (CODE 510) 8th St. and S. Courthouse Rd. Washington, DC 20305
1	Under Secretary of Defense for Research and Engineering Department of Defense Washington, DC 20301	4	Director Defense Nuclear Agency ATTN: SPTD, Mr. T.E. Kennedy DDSI (E), Dr. E. Sevin OALG, Mr. T.P. Jeffers LEEE, Mr. J. Eddy Washington, DC 20305
1	Director of Defense Research and Engineering Washington, DC 20301		
1	Assistant Secretary of Defense (MRA&L) ATTN: EO&SP Washington, DC 20301	1	HQDA (DALO-SMA) ATTN: Col. W.F. Paris II Washington, DC 20310
1	Assistant Secretary of Defense (Atomic Energy) ATTN: Document Control Washington DC 20301	1	AFWAL Wright-Patterson AFB, OH 45433
1	Director Defense Advanced Research Projects Agency 1400 Wilson Boulevard Arlington, VA 22209	2	AFLC (MMW/CPT D. Rideout; IGYE/K. Shopker) Wright-Patterson AFB, OH 45433

DISTRIBUTION LIST

<u>No. of Copies</u>	<u>Organization</u>	<u>No. of Copies</u>	<u>Organization</u>
1	Commander Air Force Armament Laboratory ATTN: DLYV, Mr. R. L. McGuire Eglin AFB, FL 32542	3	AFML (LNN, Dr. T. Nicholas; MAS; MBC, Mr.D. Schmidt) Wright-Patterson AFB, OH 45433
1	Ogden ALC/MMWRE ATTN: (Mr. Ted E. Comins) Hill AFB, UT 84056	1	FTD (ETD) Wright-Patterson AFB, OH 45433
5	AFWL (DEO, Mr. F.H.Peterson) SYT, MAJ W.A. Whitaker; SRR, WSUL, SR) Kirtland AFB, NM 87117	1	Mr. Richard W. Watson Director, Pittsburgh Mining & Safety Research Center Bureau of Mine, Dept of the Interior 4800 Forbes Avenue Pittsburgh, PA 15213
1	Director of Aerospace Safety HQ, USAF ATTN: JGD/AFISC (SEVV), COL J.E.McQueen Norton AFB, CA 92409	1	Headquarters Energy Research and Development Administration Department of Military Applications Washington, DC 20545
2	HQ, USAF ATTN: IDG/AFISC, (SEW) W.F. Gavitt, Jr. (SEV) Mr. K.R. Sopher Norton AFB, CA 92409	1	Director Office of Operational and Environmental Safety US Department of Energy Washington, DC 20545
2	Director Joint Strategic Target Planning Staff ATTN: JLTW; TPTP OFFUTT AFB Omaha, NE 68113	1	Commander Dugway Proving Ground ATTN: STEDP-TO-H, Mr. Miller Dugway, UT 84022
1	HQ AFESC/RDC Walter Buckholtz Tyndall AFB, FL 32403	1	Commander US Army Foreign Science and Technology Center ATTN: RSCH & Data Branch Federal Office Building 220-7th Street, NE Charlottesville, VA 22901
1	AFESC/RDC Tyndall AFB, FL 32403	10	Central Intelligence Agency Office of Central Reference Dissemination Branch Room GE-47 HQS Washington, D.C. 20502
1	Albuquerque Operations Office US Department of Energy ATTN: Div. of Operational Safety P. O. Box 5400 Albuquerque, NM 87115		

DISTRIBUTION LIST

<u>No. of Copies</u>	<u>Organization</u>	<u>No. of Copies</u>	<u>Organization</u>
2	Director Lewis Directorate US Army Air Mobility Research and Development Laboratory Lewis Research Center ATTN: Mail Stop 77-5 21000 Brookpark Road Cleveland, OH 44135	1	Director AMC, ITC ATTN: Dr. Chiang Red River Depot Texarkana, TX 75501
1	Commander US Army Harry Diamond Labs ATTN: DELHD-TI 2800 Powder Mill Road Adelphi, MD 20783	1	Commander US Army Armament Research and Development Center US Army AMCCOM ATTN: SMCAR-LCM-SP Dover, NJ 07801
1	Commander US Army Missile Command ATTN: AMSMI-RX, Mr. W. Thomas Redstone Arsenal, AL 35898	2	Commander US Army Armament Material Readiness Command ATTN: Joint Army-Navy-Air Force Conventional Ammunition Prof Coord GP/El Jordan Rock Island, IL 61299
1	Commander US Army Missile Command ATTN: AMSMI-RR, Mr. L. Lively Redstone Arsenal, AL 35898	1	Commander Pine Bluff Arsenal Pine Bluff, AR 71601
1	Commander US Army Belvoir Research and Development Center ATTN: SIRBE-ND Fort Belvoir, VA 22060	1	Commander Louisiana Army Ammunition Plant Shreveport, LA 71102
1	Commander US Army Natick Research and Development Laboratories ATTN: AMDNA-D, Dr. D. Seiling Natick, MA 01760	1	Commander US Army Missile Command ATTN: AMSMI-R, Mr. Rob Cobb Redstone Arsenal, AL 35898
1	Commander US Army Rock Island Arsenal Rock Island, IL 61299	1	Commander Iowa Army Ammunition Plant Burlington, IA 52601
1	Commanding General US Army Armament Command ATTN: AMSMC-SA Rock Island Arsenal Rock Island, IL 61201	1	Commander Indiana Army Ammunition Plant Charlestown, IN 47111

DISTRIBUTION LIST

<u>No. of Copies</u>	<u>Organization</u>	<u>No. of Copies</u>	<u>Organization</u>
1	Commander Joliet Army Ammunition Plant Joliet, IL 60436	1	Commander Milan Army Ammunition Plant Milan, TN 38358
1	Commander Kansas Army Ammunition Plant Parsons, KS 67357	1	Commander Radford Army Ammunition Plant Radford, VA 24141
1	Commander Lone Star Army Ammunition Plant Texarkana, TX 75502	1	Commander Ravenna Army Ammunition Plant Ravenna, OH 44266
1	Commander Longhorn Army Ammunition Plant Marshall, TX 75671	1	Commander Field Command Defense Nuclear Agency ATTN: Tech Lib, FCWS-SC Kirtland AFB, NM 87115
1	HODA (DAEN-RDZ-A, Dr. Choromokos) Washington, DC 20310	1	HQDA (DAMA-CSM-CA) Washington, DC 20310
1	Commander US Army Europe ATTN: AEAGA-BE, Mr. P. Morgan APO New York, NY 09801	1	HQDA (DAMA-AR; NCL Div) Washington, DC 20310
1	HQDA (DAPE-HRS) Washington, DC 20310	1	HQDA (DAMA-NCC, COL R. D. Orton) Washington, DC 20310
1	HQDA (DAEN-MCC-D/Mr. L. Foley) Washington, DC 20310	1	HQDA (DAEN-ROL, Mr. Simonini) Washington, DC 20310
1	HQDA (DAEN-ECE-T/Mr. R.L. Wight) Washington, DC 20310	1	Director US Army Engineer Waterways Experiment Station ATTN: WESNP P.O. Box 631 Vicksburg, MS 39130
1	Director US Army RMD Advanced Technology Center ATTN: M. Whitfield P.O. Box 1500 Huntsville, AL 35807	1	Commander US Army Materiel Command ATTN: AMCDRA 5001 Eisenhower Avenue Alexandria, VA 22333-0001
1	Commander US Army Ballistic Missile Defense Systems Command ATTN: J. Veeneman P. O. Box 1500, West Station Huntsville, AL 35807		

DISTRIBUTION LIST

<u>No. of Copies</u>	<u>Organization</u>	<u>No. of Copies</u>	<u>Organization</u>
1	Division Engineer US Army Engineer Division Fort Belvoir, VA 22060	1	Commander US Army Materiel Command ATTN: AMCSF 5001 Eisenhower Avenue Alexandria, VA 22333-0001
1	US Army Engineer Division ATTN: Mr. Char P. O. Box 1600 Huntsville, AL 35807	1	Director AMC Field Safety Activity ATTN: AMXOS-OES Charlestown, IN 47111-9669
1	Commandant US Army Engineer School ATTN: ATSE-CD Fort Belvoir, VA 22060	1	Office of Inspector General Department of Defense ATTN: DAIG-SD Washington, DC 20310
1	Commander US Army Construction Engineering Research Lab P.O. Box 4005 Champaign, IL 61820	1	Commander US Army Engineer Div. Europe ATTN: EUDED, Dr. Roger Crowson APO New York, NY 09757
1	Chief of Research, Development, and Acquisition Department of the Army ATTN: DAMA-CSN-CA Mr. Lippi Washington, DC 20310	1	Commander US Army Research Office P. O. Box 12211 Research Triangle Park NC 27709-2211
1	Assistant Secretary of the Navy (Rsch & Dev) Navy Development Washington, DC 20350	1	Commander Naval Air Systems Command ATTN: AIR 532 Washington, DC 20360
3	Chief of Naval Operation ATTN: OP-411, C. Ferraro, Jr. CPT. R. L. Wernsman OP-41B, Washington, DC 20350	1	Commander Naval Sea Systems Command ATTN: SEA-Q6H M.R. Van Slyke Washington, DC 20362
1	Commander US Army Materials and Mechanics Research Center ATTN: AMXMR-ATL Watertown, MA 02172	1	Commander Naval Sea Systems Command ATTN: SEA-0333 Washington, DC 20362
		1	Commander Naval Facilities Engineering Command ATTN: Code 04T5 Washington, DC 22360

DISTRIBUTION LIST

<u>No. of Copies</u>	<u>Organization</u>	<u>No. of Copies</u>	<u>Organization</u>
1	Commander USA Safety Center ATTN: PESC-Z Ft. Rucker, AL 36362-5363	1	AFRPL Edwards AFB, CA 93523
1	Institute of Makers of Explosives ATTN: Mr. F. P. Smith, Jr., Executive Director 1575 Eve St., N.W., Suite 550 Washington, DC 20005	1	ADTC Eglin AFB, FL 32542
1	Director Lawrence Livermore Laboratory Technical Information Division P. O. Box 808 Livermore, CA 94550	1	Agbabian Associates ATTN: Dr. D. P. Reddy 250 N. Nash Street El Segundo, CA 90245
1	Director Los Alamos Scientific Lab ATTN: Dr. J. Taylor P. O. Box 1663 Los Alamos, NM 87545	1	Director National Aeronautics and Space Administration Scientific and Technical Information Facility P. O. Box 8757 Baltimore/Washington International Airport, MD 21240
2	Director Sandia National Laboratories ATTN: Info Dist Div Dr. W. A. von Rieseemann Albuquerque, NM 87115	1	National Academy of Science ATTN: Mr. D. G. Groves 2101 Constitution Avenue, NW Washington, DC 20418
1	Director National Aeronautics and Space Administration George C. Marshall Space Flight Center Huntsville, AL 35812	1	Aeronautical Research Associates of Princeton, Inc. ATTN: Dr. C. Donaldson 50 Washington Road, P.O.Box 2229 Princeton, NJ 08540
2	Director National Aeronautics and Space Administration Aerospace Safety Research and Data Institute 21000 Brook Park Road Lewis Research Center Cleveland, OH 44135	1	General American Transportation Corp. General American Research Div. ATTN: Dr. J. C. Shang 7449 N. Natchez Avenue Niles, IL 60648
		1	Hercules, Inc. ATTN: Billings Brown Box 93 Magna, UT 84044

DISTRIBUTION LIST

<u>No. of Copies</u>	<u>Organization</u>	<u>No. of Copies</u>	<u>Organization</u>
1	Commander Naval Surface Weapons Center Dahlgren Laboratory ATTN: E-23, Mr. J.J.Walsh Dahlgren, VA 22448	2	Commander David W. Taylor Naval Ship Research & Development Center ATTN: Mr. A. Wilner, Code 1747 Mr. W.J.Murray, Code 17 Bethesda, MD 20084
1	Commander Naval Weapons Center ATTN: Code 0632, Mr. G. Ostermann China Lake, CA 93555	3	Commander Naval Surface Weapons Center ATTN: Dr. Leon Schindel Dr. Victor Dawson Dr. P. Huange Silver Spring, MD 20910
1	Commander Naval Ship Research and Development Center Facility ATTN: Mr. Lowell T. Butt Underwater Explosions Research Division Portsmouth, VA 23709	2	Commander Naval Surface Weapons Center White Oak Laboratory ATTN: R-15, Mr. M.M.Swisdak Mr. W.D. Smith III Silver Spring, MD 20910
1	Commanding Officer Naval Weapons Support Center (Code 502) Crane, IN 47522	1	Officer in Charge (Code L31) Civil Engineering Lab ATTN: Code L51, Mr. W. A. Keenan Naval Construction Battalion Center Port Hueneme, CA 93041
1	Officer in Charge Naval EOD Facility ATTN: Code D, Mr. L. Dickenson Indian Head, MD 20640	2	Superintendent Naval Postgraduate School ATTN: Tech Reports Sec. Code 57, Prof. R. Ball Monterey, CA 93940
1	Commander Naval Weapons Evaluation Facility ATTN: Document Control Kirtland AFB Albuquerque, NM 87117	1	HQ USAF (AFNIE-CA) Washington, DC 20330
1	Commander Naval Research Laboratory ATTN: Code 2027, Tech Lib Washington, DC 20375	3	HQ USAF (AFRIDQ; AFRODXM; AFRDPM) Washington, DC 20330
1	Air Force Systems Command ATTN: ICFW-840303 Andrews AFB Washington, DC 20334	1	AFTAWC (OA) Eglin AFB, FL 32542

DISTRIBUTION LIST

<u>No. of Copies</u>	<u>Organization</u>	<u>No. of Copies</u>	<u>Organization</u>
2	The Boeing Company Aerospace Division ATTN: Dr. Peter Grafton Dr. D. Strome Mail Stop 8C-68 P. O. Box 3707 Seattle, WA 98124	2	Kaman-AviDyne ATTN: Dr. N.P.Hobbs Mr. S. Criscione Northwest Industrial Park 83 Second Avenue Burlington, MA 01803
1	Aerospace Corporation P.O. Box 92957 Los Angeles, CA 90009	1	J. G. Engineering Research Associates 3831 Menlo Drive Baltimore, MD 21215
2	AVCO Corporation Structures and Mechanics Dept. ATTN: Dr. William Broding Dr. J. Gilmore 201 Lowell Street Wilmington, MA 01887	3	Kaman-Nuclear ATTN: Dr. F. H. Shelton Dr. D. Sachs Dr. R. Keffe 1500 Garden of the Gods Road Colorado Springs, CO 80907
2	Battelle Memorial Institute ATTN: Dr. L. E. Hulbert Mr. J. E. Backofen, Jr. 505 King Avenue Columbus, OH 43201	1	Knolls Atomic Power Laboratory ATTN: Dr. R. A. Powell Schenectady, NY 12309
1	Black & Veatch Consulting Engineers ATTN: Mr. H. L. Callahan 1500 Meadow Lake Parkway Kansas City, MO 64114	1	Lovelace Research Institute ATTN: Dr. E. R. Fletcher P. O. Box 5890 Albuquerque, NM 87115
2	Martin Marietta Corporation ATTN: Dr. P. F. Jordan Mr. R. Goldman 1450 S. Rolling Road Baltimore, MD 21227	1	Georgia Institute of Tech ATTN: Dr. S. Atluri 225 North Avenue, NW Atlanta, GA 30332
1	Mason & Hanger-Silas Mason Co., Inc. Plantex Plant P. O. Box 647 Amarillo, TX 79117	1	IIT Research Institute ATTN: Mrs. H. Napadenskv 10 West 35 Street Chicago, IL 60616
1	McDonnell Douglas Astronautics Western Division ATTN: Dr. Lea Cohen 5301 Bosla Avenue Huntington Beach, CA 92647	1	Massachusetts Institute of Technology Aeroelastic and Structures Research Laboratory ATTN: Dr. E. A. Witmar Cambridge, MA 02139

DISTRIBUTION LIST

<u>No. of Copies</u>	<u>Organization</u>	<u>No. of Copies</u>	<u>Organization</u>
1	Monsanto Research Corporation Mound Laboratory ATTN: Frank Neff Miamisburg, OH 45342	1	DNA Information and Analysis Center Kaman Tempo ATTN: DASIAC 816 State Street P.O. Drawer QQ Santa Barbara, CA 93102
1	Physics International 2700 Merced Street San Leandro, CA 94577	3	Southwest Research Institute ATTN: Dr. H. N. Abramson Dr. W. E. Baker Dr. U. S. Lindholm 8500 Culebra Road San Antonio, TX 78228
1	R&D Associates ATTN: Mr. John Lewis P. O. Box 9695 Marina del Rey, CA 90291	1	Ammann & Whitney ATTN: Mr. N. Dobbs Suit 1700 Two World Trade Center New York, NY 10048
1	Science Applications, Inc. 1215 Jefferson Davis Highway Suite 310 Arlington, VA 22202	1	Texas A&M University Department of Aerospace Engineering ATTN: Dr. James A. Stricklin College Station, TX 77843
1	Brown University Division of Engineering ATTN: Prof. R. Clifton Providence, RI 02912	1	University of Alabama ATTN: Dr. T. L. Cost P. O. Box 2908 University, AL 35486
1	Florida Atlantic University Dept. of Ocean Engineering ATTN: Prof. K. K. Stevens Boca Raton, FL 33432	<u>Aberdeen Proving Ground</u> Dir, USAMSAA ATTN: AMXSY-D AMXSY-MP, H. Cohen Cdr, USATECOM ATTN: AMSTE-TO-F Cdr, CRDC, AMCCOM ATTN: SMCCR-RSP-A SMCCR-MU SMCCR-SPS-IL Cdr, US Army Toxic and Hazardous Materials Agency ATTN: AMXTH-TE	
1	University of Delaware Department of Mechanical and Aerospace Engineering ATTN: Prof. J. R. Vinson Newark, DE 19711		
1	R & D Associates ATTN: G. P. Ganong P. O. Box 9335 Albuquerque, NM 87119		
1	Applied Research Associates, Inc. ATTN: Mr. J.L. Drake 2244 Openwood Street Wichita, KS 67201		

USER EVALUATION SHEET/CHANGE OF ADDRESS

This Laboratory undertakes a continuing effort to improve the quality of the reports it publishes. Your comments/answers to the items/questions below will aid us in our efforts.

1. BRL Report Number _____ Date of Report _____

2. Date Report Received _____

3. Does this report satisfy a need? (Comment on purpose, related project, or other area of interest for which the report will be used.) _____

4. How specifically, is the report being used? (Information source, design data, procedure, source of ideas, etc.) _____

5. Has the information in this report led to any quantitative savings as far as man-hours or dollars saved, operating costs avoided or efficiencies achieved, etc? If so, please elaborate. _____

6. General Comments. What do you think should be changed to improve future reports? (Indicate changes to organization, technical content, format, etc.) _____

CURRENT
ADDRESS

Name

Organization

Address

City, State, Zip

7. If indicating a Change of Address or Address Correction, please provide the New or Correct Address in Block 6 above and the Old or Incorrect address below.

OLD
ADDRESS

Name

Organization

Address

City, State, Zip

(Remove this sheet along the perforation, fold as indicated, staple or tape closed, and mail.)

FOLD HERE

Director
U.S. Army Ballistic Research Laboratory
ATTN: SLCBR-DD-T
Aberdeen Proving Ground, MD 21005-5066



NO POSTAGE
NECESSARY
IF MAILED
IN THE
UNITED STATES

OFFICIAL BUSINESS
PENALTY FOR PRIVATE USE, \$300

BUSINESS REPLY MAIL
FIRST CLASS PERMIT NO 12062 WASHINGTON, DC
POSTAGE WILL BE PAID BY DEPARTMENT OF THE ARMY

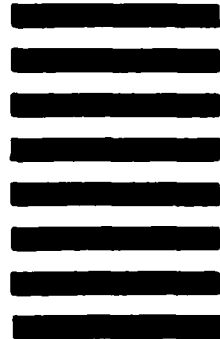

Director
U.S. Army Ballistic Research Laboratory
ATTN: SLCBR-DD-T
Aberdeen Proving Ground, MD 21005-9989

FOLD HERE