

MICROCOPY RESOLUTION TEST CHART
NATIONAL BUREAU OF STANDARDS-1963-A

AD-A163 204

2

FTD-ID(RS)T-0887-85

FOREIGN TECHNOLOGY DIVISION



DTIC
ELECTE
JAN 22 1986
S **D**
D

A MIRROR MAGNIFIER

by

M.N. Sokol'skiy



DTIC FILE COPY

Approved for public release;
distribution unlimited.



86 1 22 044

EDITED TRANSLATION

FTD-ID(RS)T-0887-85

13 Dec 85

MICROFICHE NR: FTD-85-C-001266

A MIRROR MAGNIFIER

By: M.N. Sokol'skiy

English pages: 4

Source: USSR Patent Nr. 312166, 19 August 1971,
pp. 1-2

— Country of origin: USSR
Translated by: FLS, INC.
F33657-85-D-2079

Requester: FTD/TQTD

Approved for public release; distribution unlimited.

Accession For	
NTIS CRA&I	<input checked="" type="checkbox"/>
DTIC TAB	<input type="checkbox"/>
Unannounced	<input type="checkbox"/>
Justification	
By	
Distribution/	
Availability Codes	
Dist	Avail and/or Special
A-1	

THIS TRANSLATION IS A RENDITION OF THE ORIGINAL FOREIGN TEXT WITHOUT ANY ANALYTICAL OR EDITORIAL COMMENT. STATEMENTS OR THEORIES ADVOCATED OR IMPLIED ARE THOSE OF THE SOURCE AND DO NOT NECESSARILY REFLECT THE POSITION OR OPINION OF THE FOREIGN TECHNOLOGY DIVISION.

PREPARED BY:

TRANSLATION DIVISION
FOREIGN TECHNOLOGY DIVISION
WP.AFB, OHIO.



U. S. BOARD ON GEOGRAPHIC NAMES TRANSLITERATION SYSTEM

Block	Italic	Transliteration	Block	Italic	Transliteration.
А а	<i>А а</i>	A, a	Р р	<i>Р р</i>	R, r
Б б	<i>Б б</i>	B, b	С с	<i>С с</i>	S, s
В в	<i>В в</i>	V, v	Т т	<i>Т т</i>	T, t
Г г	<i>Г г</i>	G, g	У у	<i>У у</i>	U, u
Д д	<i>Д д</i>	D, d	Ф ф	<i>Ф ф</i>	F, f
Е е	<i>Е е</i>	Ye, ye; E, e*	Х х	<i>Х х</i>	Kh, kh
Ж ж	<i>Ж ж</i>	Zh, zh	Ц ц	<i>Ц ц</i>	Ts, ts
З з	<i>З з</i>	Z, z	Ч ч	<i>Ч ч</i>	Ch, ch
И и	<i>И и</i>	I, i	Ш ш	<i>Ш ш</i>	Sh, sh
Й й	<i>Й й</i>	Y, y	Щ щ	<i>Щ щ</i>	Shch, shch
К к	<i>К к</i>	K, k	Ъ ъ	<i>Ъ ъ</i>	"
Л л	<i>Л л</i>	L, l	Ы ы	<i>Ы ы</i>	Y, y
М м	<i>М м</i>	M, m	Ь ь	<i>Ь ь</i>	'
Н н	<i>Н н</i>	N, n	Э э	<i>Э э</i>	E, e
О о	<i>О о</i>	O, o	Ю ю	<i>Ю ю</i>	Yu, yu
П п	<i>П п</i>	P, p	Я я	<i>Я я</i>	Ya, ya

*ye initially, after vowels, and after ь, ь; e elsewhere.
When written as ë in Russian, transliterate as yë or ë.

RUSSIAN AND ENGLISH TRIGONOMETRIC FUNCTIONS

Russian	English	Russian	English	Russian	English
sin	sin	sh	sinh	arc sh	sinh ⁻¹
cos	cos	ch	cosh	arc ch	cosh ⁻¹
tg	tan	th	tanh	arc th	tanh ⁻¹
ctg	cot	cth	coth	arc cth	coth ⁻¹
sec	sec	sch	sech	arc sch	sech ⁻¹
cosec	csc	csch	csch	arc csch	csch ⁻¹

Russian English

rot curl
lg log

GRAPHICS DISCLAIMER

All figures, graphics, tables, equations, etc. merged into this translation were extracted from the best quality copy available.

The device also contains elements for regulating the angle of incidence of the light on mirror 2, schematically depicted in the form of a pair of rotating wedges 9, elements for regulating the distance between the mirrors 2 and 3, which may be, e.g., micrometer screws. Between the collimator 5 and the mirror 2 there is a diaphragm 10, cutting out two narrow light beams 11,12 from the incident light. Beam 11 experiences refraction in the wedge, and therefore the angle between the beams gradually increases by an amount that depends only on the size of the angle β between mirrors 2,3 and the angle of the inspected wedge α . The distance between beams 11,12 in the focal plane of the system is determined directly by the angle of the inspected wedge.

Thus, measuring the angle of a wedge in such device consists in measuring the distance between beams 11,12 in the focal plane F of the system 6, the angle γ of which distance is:

$$\gamma = [2(n-1)\alpha + 2\beta] N - 2\beta N,$$

where n is the index of refraction of the wedge, N is the number of reflections from mirror 2.

For an optimal number of reflections N , the angle of incidence of the beams θ on mirror 2 or the distance between the mirrors t is regulated to maintain the relationship:

$$\sin\theta \approx \frac{p}{2N},$$

where p is the distance between the optical axes of the collimator 5 and the focusing system 6.

Besides the above, other modifications of the device are possible. In particular, the collimator 5 and the focusing system 6 may be combined, i.e. built as an autocollimator; it is

possible to use different versions of regulation and measurement components, and so forth.

Enhanced measurement precision is achieved by the presence of elements to separate the incident light into two parallel beams, mutually displaced in the direction perpendicular to the principal cross section of the inspected wedge so that, during repeated reflection from the mirrors, only one beam passes through the wedge. The angle between both beams at the output is determined solely by the angle of the inspected wedge, and does not depend on the precision of manufacture or adjustment of the mirrors.

Patent Claims

A mirror magnifier, containing a light with collimator, a system of mirrors and an output registration system, distinct by the fact that, to enhance the measurement precision of wedgelike objects placed in the space between the mirrors, behind the collimator there is a diaphragm with two openings, the orthogonal projection of one which onto the plane perpendicular to the principal cross section of the object is covered by the trace of the object on this plane, while the projection of the other opening lies outside this trace.

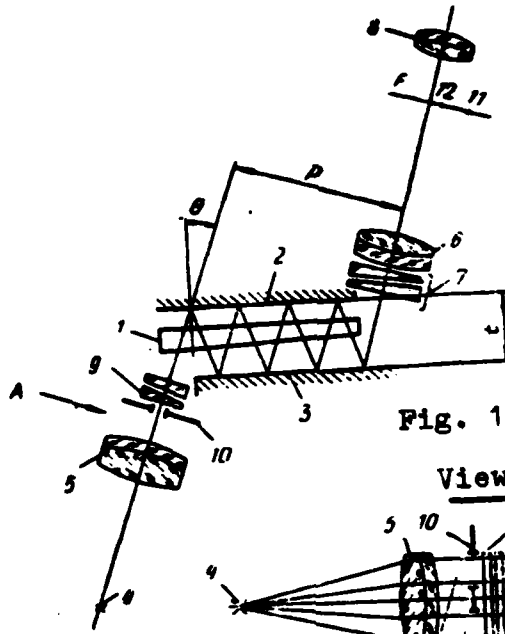

Fig. 1

View A

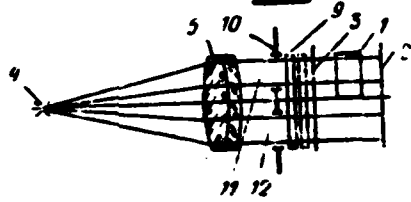

Fig. 2

END

FILMED

2-86

DTIC