

MICROCOPY RESOLUTION TEST CHART  
NATIONAL BUREAU OF STANDARDS-1963-A

12

# A Microcomputer Pollution Model for Civilian Airports and Air Force Bases USER'S GUIDE



US Department of Transportation  
**Federal Aviation Administration**  
Office of Environment and Energy  
Washington, D.C. 20591



**United States Air Force**  
Engineering Services Center  
Tyndall Air Force Base, Florida 32403

---

December 1985

AD-A163 232

DTIC  
ELECTE  
S JAN 21 1986 D  
E

DTIC FILE COPY

---

H.M. Segal  
J.K. Kemp  
P.L. Hamilton

FAA Report No. FAA-EE-85-4

USAF Report No. ESL-TR-85-41

NOTICE

This document is disseminated under the sponsorship of the Department of Transportation in the interest of information exchange. The United States Government assumes no liability for the contents or use thereof.

The United States Government does not endorse products or manufacturers. Trade or manufacturer's names appear herein solely because they are considered essential to the object of this report.

Technical Report Documentation Page

1. Report No. (FAA) FAA-EE-85-4 (USAF) ESL-TR-85-41		2. Government Accession No. <i>AD A163 232</i>		3. Recipient's Catalog No.	
4. Title and Subtitle A MICROCOMPUTER POLLUTION MODEL FOR CIVILIAN AIRPORTS AND AIR FORCE BASES - USER'S GUIDE				5. Report Date DECEMBER 1985	
				6. Performing Organization Code	
7. Author(s) H. M. SEGAL                  J. K. KEMP*                  P. L. HAMILTON**				8. Performing Organization Report No. DOT/FAA	
9. Performing Organization Name and Address FEDERAL AVIATION ADMINISTRATION OFFICE OF ENVIRONMENT AND ENERGY 800 INDEPENDENCE AVENUE, SW. WASHINGTON, D.C. 20591				10. Work Unit No. (TRAVIS)	
				11. Contract or Grant No.	
12. Sponsoring Agency Name and Address THE EDMS PROGRAM IS BEING JOINTLY FUNDED BY THE FAA (SEE ABOVE) AND THE USAF ENGINEERING SERVICES CENTER, TYNDALL AIR FORCE BASE, FLORIDA 32403				13. Type of Report and Period Covered USER'S GUIDE	
				14. Sponsoring Agency Code AEE-30 (FAA);AFESC/RDVA(USAF)	
15. Supplementary Notes * WILSON HILL ASSOCIATES, 1220 "L" STREET, NW., WASHINGTON, D.C. 20005 ** PAUL HAMILTON ASSOCIATES, 1050 CONNECTICUT AVENUE, NW., WASHINGTON, D.C. 20036					
16. Abstract  Over the past five years, the Federal Aviation Administration (FAA) and the United States Air Force (USAF) have developed a number of user-friendly emissions and dispersion models for air quality assessment purposes. The first, Simplex "A," was completed in July 1981. The second, called "Emissions and Dispersion Modeling System" (EDMS), has just been completed and this report constitutes its User's Guide.  First, this User's Guide shows how the EDMS system evolved from the earlier, more complex AVAP and AQAM systems. Then, it identifies the hardware and software required to run the system and provides instructions on how to add, delete or change standard information. Finally, through a 125-step example problem, it instructs the user on how to input and process data to produce:  1. an emissions inventory of all sources at an airport/airbase, and 2. an estimate of the concentrations of these sources at specified locations.  An inexperienced user should be able to process the example problem in less than three hours.					
17. Key Words POLLUTION, AIR POLLUTION, DISPERSION MODEL, EMISSIONS MODEL, DATA BASE, MICROCOMPUTER			18. Distribution Statement THIS DOCUMENT IS AVAILABLE TO THE PUBLIC THROUGH THE NATIONAL TECHNICAL INFORMATION SERVICE, SPRINGFIELD, VA 22161.		
19. Security Classif. (of this report) UNCLASSIFIED		20. Security Classif. (of this page) UNCLASSIFIED		21. No. of Pages	22. Price

TABLE OF CONTENTS

	Page Number
I INTRODUCTION -----	1
II APPROACH -----	2
III HARDWARE AND SOFTWARE REQUIREMENTS-----	2
IV SYSTEM START-UP, LOAD AND CHANGE-----	3
V EXAMPLE PROBLEM -----	5
REFERENCES	
APPENDIX A: PROCEDURES FOR CHANGING DATA FILES -----	43
APPENDIX B: MODEL VALIDATION -----	45
APPENDIX C: EXAMPLE PROBLEM RESULTS -----	51

Accession For	
NTIS GRA&I	<input checked="" type="checkbox"/>
DTIC TAB	<input type="checkbox"/>
Unannounced	<input type="checkbox"/>
Justification	
By _____	
Distribution/	
Availability Codes	
Dist	Avail and/or Special
A-1	



# FAA/USAF MODEL DEVELOPMENT PROGRAM

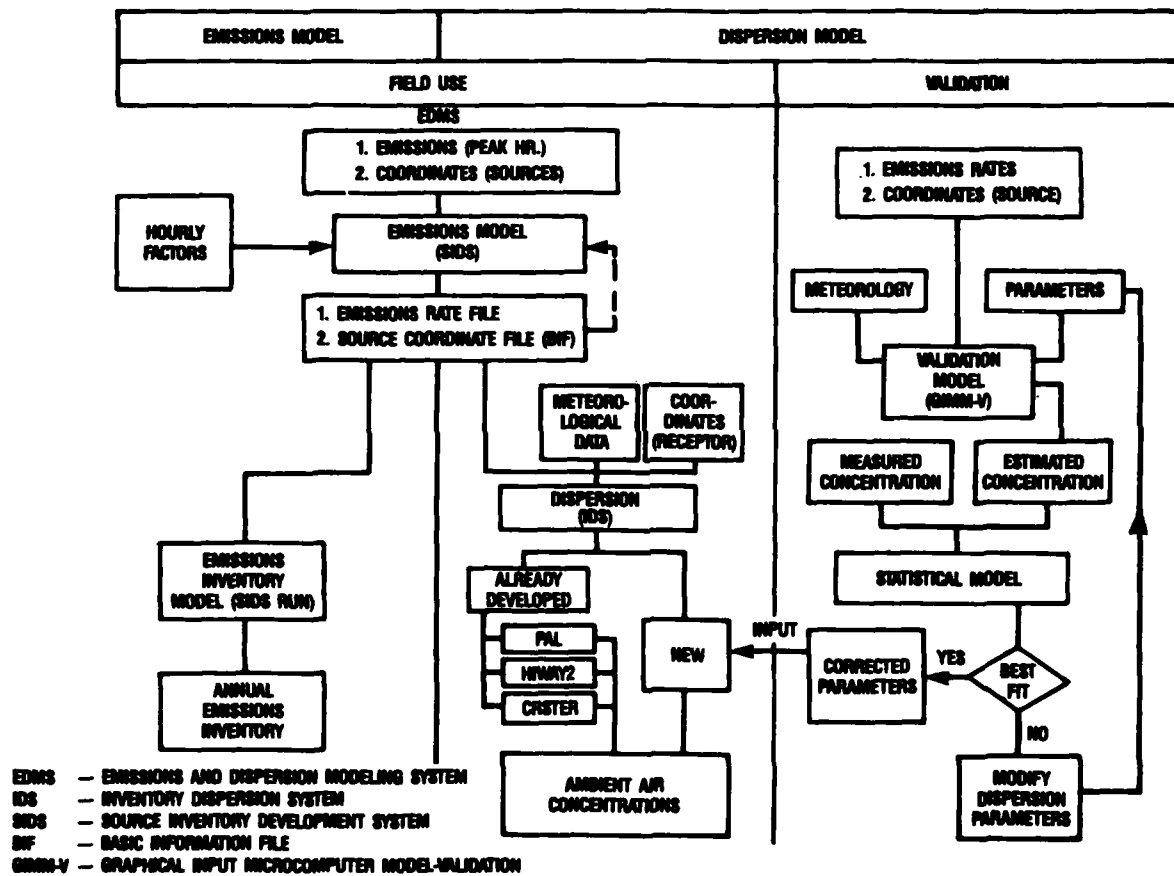

FIGURE I-1

## I - INTRODUCTION

Any expansion of operations or facilities at airports or airbases usually requires some type of an environmental assessment. In the area of air quality, this assessment usually requires the use of two models--one to prepare an inventory of emissions and the other to calculate the concentrations of these emissions as they disperse downwind.

These types of models were developed in the early 1970's by both the United States Air Force (USAF) and the Federal Aviation Administration (FAA). The USAF developed the Air Quality Assessment Model (AQAM) (Reference 1) and the FAA developed the Airport Vicinity Air Pollution model (AVAP) (Reference 2). However, these models are becoming obsolete--they are expensive to operate, tedious to input data and require a fully qualified scientist or engineer to use.

The introduction of modern microcomputers into the workplace made it possible to simplify considerably the modeling process for both emissions and dispersion assessments. Therefore, it was decided to develop a new set of emissions/dispersion models for use on microcomputers. A prime question, however, was whether to develop a separate modeling system for each agency, as was done with the earlier AVAP and AQAM systems, or whether to combine FAA and USAF requirements into a single modeling system. Because the USAF and the FAA have such similar modeling requirements, the single system approach was taken. The Emissions and Dispersion Modeling System (EDMS) was designed as the model to be used by both agencies.

EDMS employs the latest advances in computer technology. In doing so, it compensates for AQAM and AVAP limitations by employing the new, interactive, graphical input characteristics of the "Simplex A" (Reference 3) and "GIMM" (Reference 4) microcomputer models and uses a modern computer database. This simplified approach has made it possible for a layperson to do modeling previously reserved for a scientist or engineer.

A special feature of the EDMS system is its ability to create the input files for models in the USERS' NETWORK FOR APPLIED MODELING OF AIR POLLUTION (UNAMAP) system. (UNAMAP is a series of dispersion models issued by the Environmental Protection Agency (EPA)). In its present configuration, the EDMS will process files for the Point-Area-Line (PAL) (Reference 5), HIWAY-2 (Reference 6), and CRSTER (Reference 7) UNAMAP models. These files are created automatically from data previously entered interactively by the user. Since this file acts as the emissions "front end" for the appropriate UNAMAP dispersion model, the user can make a dispersion run for the particular UNAMAP model of his choice without having to reenter emissions or coordinate information. EDMS also calculates an emissions inventory of all point, line and area sources at an airport.

The EDMS system is part of a comprehensive FAA/USAF model development program. Figure I-1 shows how EDMS fits into this program.

This document provides guidance on how to use the EDMS. System details are described in Reference 8.

## II - APPROACH

The approach of this guide is to provide "hands-on" instructions to the user. The mechanism for doing this is an example problem which is introduced early in this document. Only two sections precede the example problem instructions. The first acquaints the user with the hardware and software required to run the example problem. The second describes how to load the model diskettes into the computer and start it up. The example problem is then run by following a sequence of 125 steps. The user can check his results with those printed in Appendix C. The appendices also contain model validation results and instructions on how to change standards data.

This is the first issue of the User's Guide. We plan to issue revisions to it every year. Therefore, the user is encouraged to communicate any corrections, additions or simplifications to the system that he feels will enhance its effectiveness. Telephone contacts are Howard Segal, AEE-30, 202-755-8933 for the FAA and Lt. Glen Seitchek, AFSEC/RDVA, 204-283-4234, for the USAF. Mailing address for both agencies are listed on the Technical Report Documentation Page (first page) of this report.

## III - HARDWARE AND SOFTWARE REQUIREMENTS

### 1. HARDWARE

The following is required:

- 1) One IBM-PC/XT or compatible microcomputer. One 5 1/4" floppy disk drive. One 10 megabyte hard disk drive with 5 megabytes of unused space. At least 256 kilobytes of internal memory.
- 2) One printer compatible with the above.

The following are optional items:

- 1) At least 256 kilobytes of additional internal memory
- 2) A color graphics monitor
- 3) An Intel 8087 math co-processor. This chip will significantly speed up system loading and data processing.
- 4) A graphics tablet compatible with the EDMS system. (A Houston Instruments Corporation "Hipad" graphics tablet was used in system development.)

### 2. SOFTWARE

The EDMS requires the following software:

- 1) MS-DOS version 2.0 or higher
- 2) Ten diskettes containing the EDMS

To order diskettes, contact: Federal Aviation Administration  
800 Independence Avenue, SW. (AEE-30)  
Washington, D.C. 20591  
Attn: Howard M. Segal  
Telephone: (202) 755-8933

#### IV - SYSTEM START-UP, LOAD, AND CHANGE

The computer start-up procedure is described in steps 1 through 4 of the Example Problem (Section V). The EDMS is loaded into the computer as follows:

- A. Insert EDMS disk #1 into the disk drive (there are 10 diskettes).
- B. Type "A:" then (↵) which is the keyboard symbol for carriage return.
- C. Type "EDMSBLD" then (↵) to start the load program.
- D. The contents of disk #1 will be copied into the hard disk.
- E. After disk #1 has been loaded, a prompt for disk #2 will appear on the screen. Remove disk #1 and insert disk #2 and press (↵).
- F. Repeat step E until all 10 diskettes have been loaded. Time to load the diskettes is about 2 hours.

If the user wishes to change, add or delete items in the standards data base (for example, adding emissions rates for new aircraft), he can do so by following the procedures described in Appendix A. To find out what standards information has already been loaded into the standards files (there are standards files for each source) the user should exercise the "standards" option on the appropriate source menu followed by the "inquiry" option on the following menu.

### Source-Receptor Geometry at Wash. National Airport

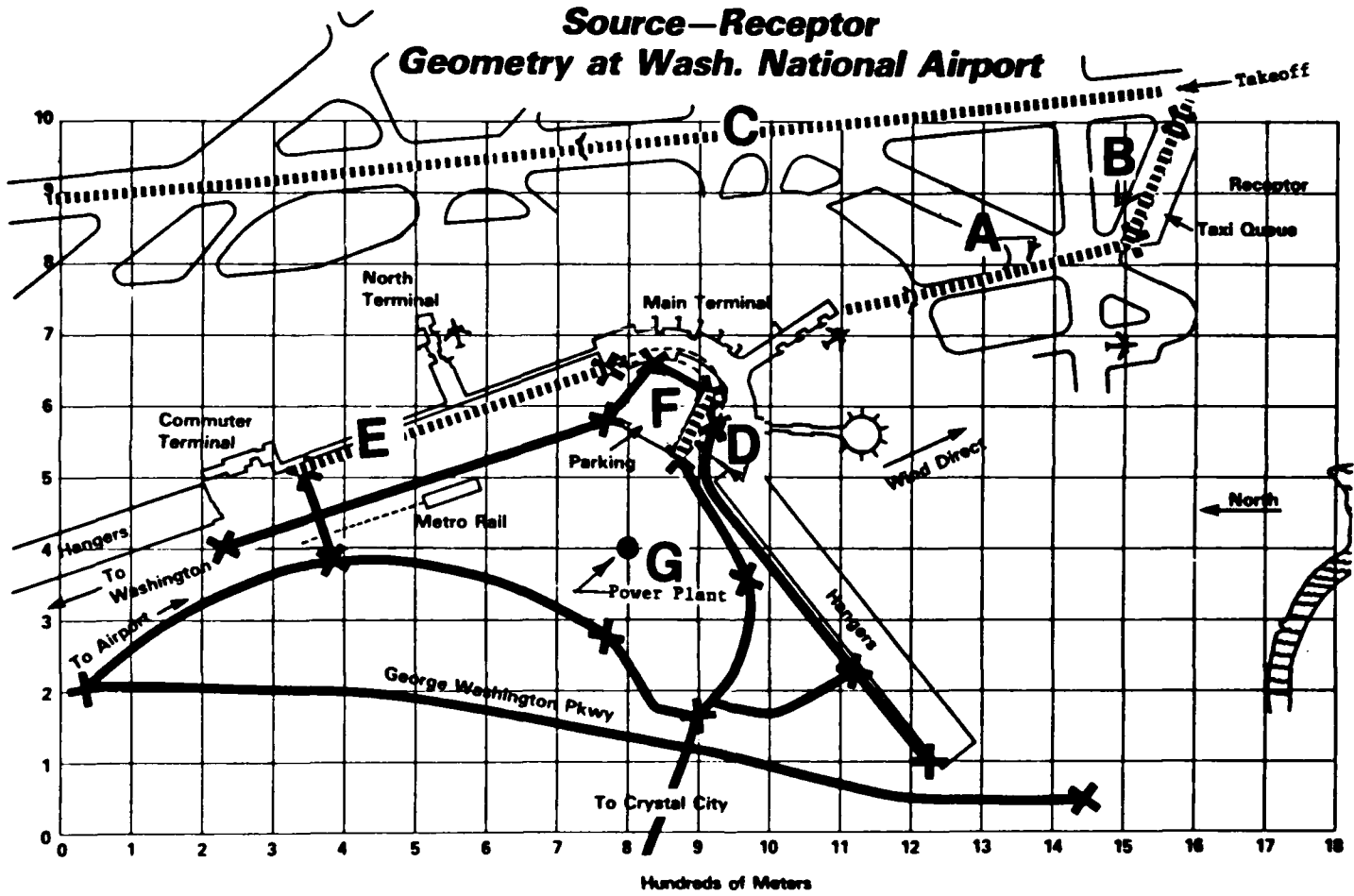

FIGURE V-1

## V - EXAMPLE PROBLEM

### V-1. INTRODUCTION

A simple source-receptor scenario has been prepared to lead the user through the steps for calculating an emissions inventory and for preparing an input file for the PAL dispersion mode. The problem is designed for an inexperienced layperson.

The source-receptor geometry for Washington National Airport is shown in Figure V-1. There are 5 receptors and 19 emission sources. Seven of these sources (letters A through G) were selected as the scenario of the example problem.

### V-2. GIVEN INFORMATION

The power plant (G) in Figure V-1 is the first source addressed. It consumes 4 metric tons of bituminous coal during its peak hour of operation. Airplanes are the second source addressed. Emissions from ten 737's and twelve 727's taxiing from the terminal area (A) to the queue area (B) and then to the takeoff runway (C) are entered. These emission values are for the hour of the year where there is peak aircraft activity. Takeoff is to the north. The third source is automobiles. Emissions from 1500 and 340 automobiles during their peak hour operation are processed for roadways (D) and (E) respectively. The parking lot (F) will have 150 vehicles per hour (in and out) during peak hour operation.

The input deck of the Point-Area-Line (PAL) dispersion model is generated for a worst case condition. This condition is estimated to occur between 5:00 and 6:00PM on a Friday afternoon during the last week in August (August 30, 1985). The worst case meteorology is: Outside Air Temperature = 75 F.; Wind Speed = 1 mph; Wind Direction = 145 deg.; Pasquill/Gifford Stability class = D.

The user is provided with a sample printout of the modeling results for one source (power plants). These results are printed out as a report of the emissions inventory of all sources entered and a report of the input file for the PAL dispersion model.

### V-3. MISCELLANEOUS INFORMATION

The computer may take some time to respond to keyboard commands. The user should make sure that the red light near the disk drive is not lighted and that a screen is displayed before issuing the next keyboard command. The word ENTER in the text means that the carriage return key (↵) should be pressed. Text entries must be in upper case since the data base distinguishes between upper and lower case characters. Quotes around numbers, characters or words are for identification only. They are not to be typed in.

### Source-Receptor Geometry at Wash. National Airport

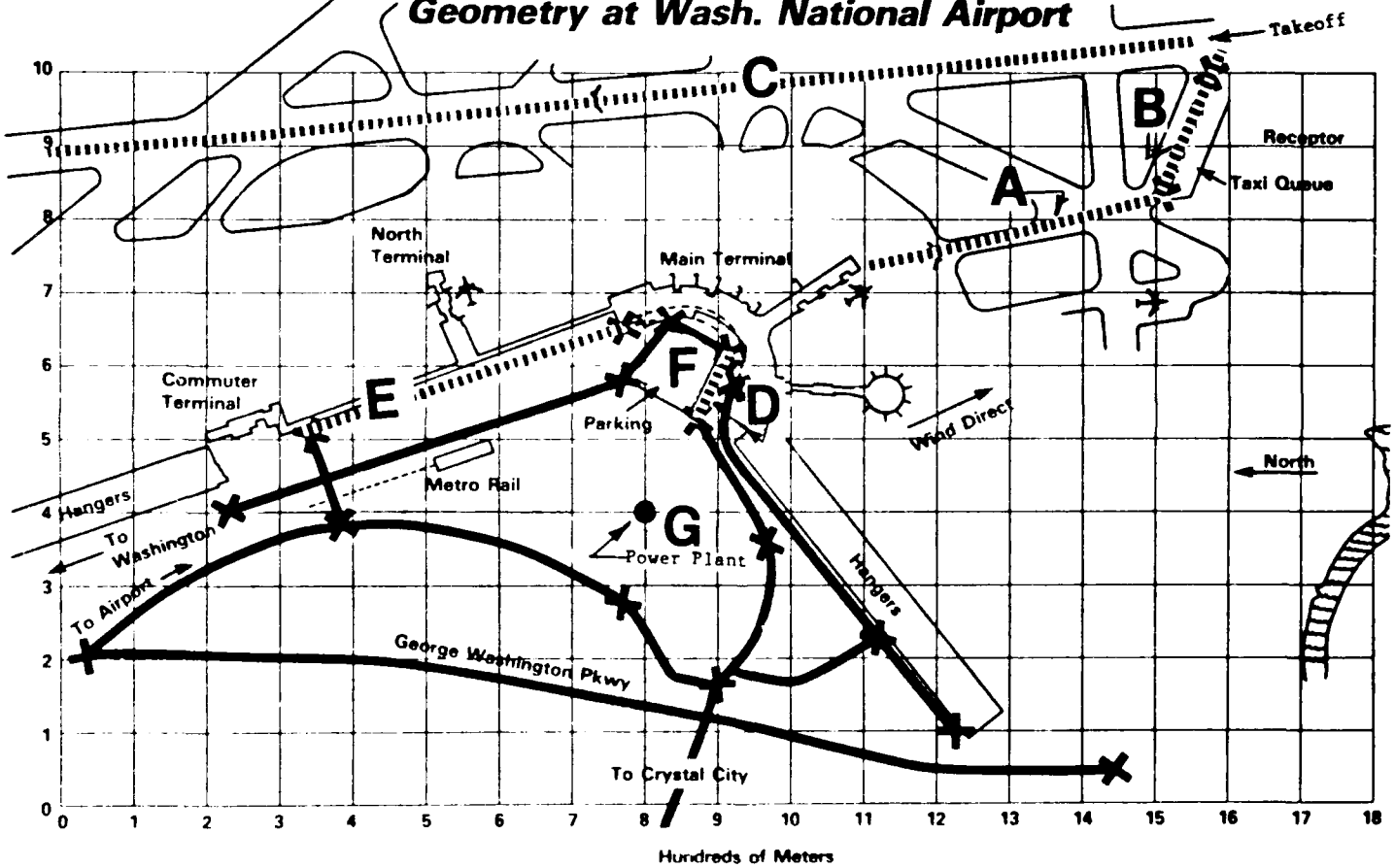

FIGURE V-1

A menu item can be entered quickly by typing the desired menu item as soon as it appears on the screen. The user does not have to wait for a complete menu display. A "C>" character on the screen means that the user has been ejected from the EDMS system--usually because of an input error. To reenter the system, type "HELP MAIN".

Data can be entered in two ways: through the "R" (revise) command displayed at the bottom of the data entry screens or by the "add new data" item displayed on the source, temporal, facility and receptor menus. The revised method is demonstrated only once - in steps 9 through 16. The "add new data" method is demonstrated many times - in the entry of all other data.

Data entry errors can be corrected on any screen (except the parking lot coordinate screen) with the "revise" command. Parking lot coordinate errors can be corrected by deleting parking lots with the "delete all sources" command on the parking lot menu and reentering parking lot data with the "add new data" command.

#### V-4. TEMPORAL FILE EXPLANATION

Power plants or other sources can have an hourly "duty cycle" varying from 100 percent-on to 100 percent-off. This duty cycle is reflected when the user enters factors of from "0" (100% off) to "1" (100% on) into the 43 fields of the temporal screen. These fields are broken down as follows: 24 hour fields - one for each hour of the day, 7 day fields - one for each day of the week, and 12 month fields - one for each month of the year. Through triple nesting these 43 entries permit the calculation of emission values for all 8760 hours of the year.



## V-5. INSTRUCTIONS - GENERAL

Menu flow to each screen is shown in Figure V-2. The shaded blocks represent all items processed in the example problem and the numbers refer to the appropriate instruction number in the example problem text. This flow chart should prove helpful if the user gets lost while exercising the example problem. This chart reappears 14 times in the example problem text with 14 different flow lines to provide an overview of each item processed.

Because the user may not have a graphics tablet, two sets of instructions have been provided--one to process the example problem using the tablet (section 5.2) (tablet-on) and the other to process the problem without using the tablet (tablet-off) (section 5.1).

Tablet-off instructions (section 5.1) should be processed first whether the user does or does not have a graphics tablet. After gaining familiarity with the system, the user having a graphics tablet can proceed to the graphics tablet instructions in section 5.2.

### V-5.1 INSTRUCTIONS - GRAPHICS TABLET-OFF

#### V-5.1.1 PREPARE FOR DATA ENTRY:

ACTION	PURPOSE
1 turn on computer, monitor and printer	activate system
2 press "ALT", "DEL", and "CTRL" keys simultaneously press "CAPS LOCK" key	boot system; preempt upper case case character entry
3 press ENTER a sufficient number of times to make the "C" or "A" character appear on the screen	make prompt character appear
4 type "C:" ENTER	make sure the system is in the "C" drive
5 type "CD EDMS" ENTER	address the EDMS system
6 type "EDMSTOFF" ENTER (33 files will be processed and displayed on the screen)	operate system without the graphics tablet (if a tablet were used EDMSTON would be typed instead)
7 type "2" ENTER	start to input data
8 type "1" ENTER	select main input menu

# Menu Flow Facility (Input Data)

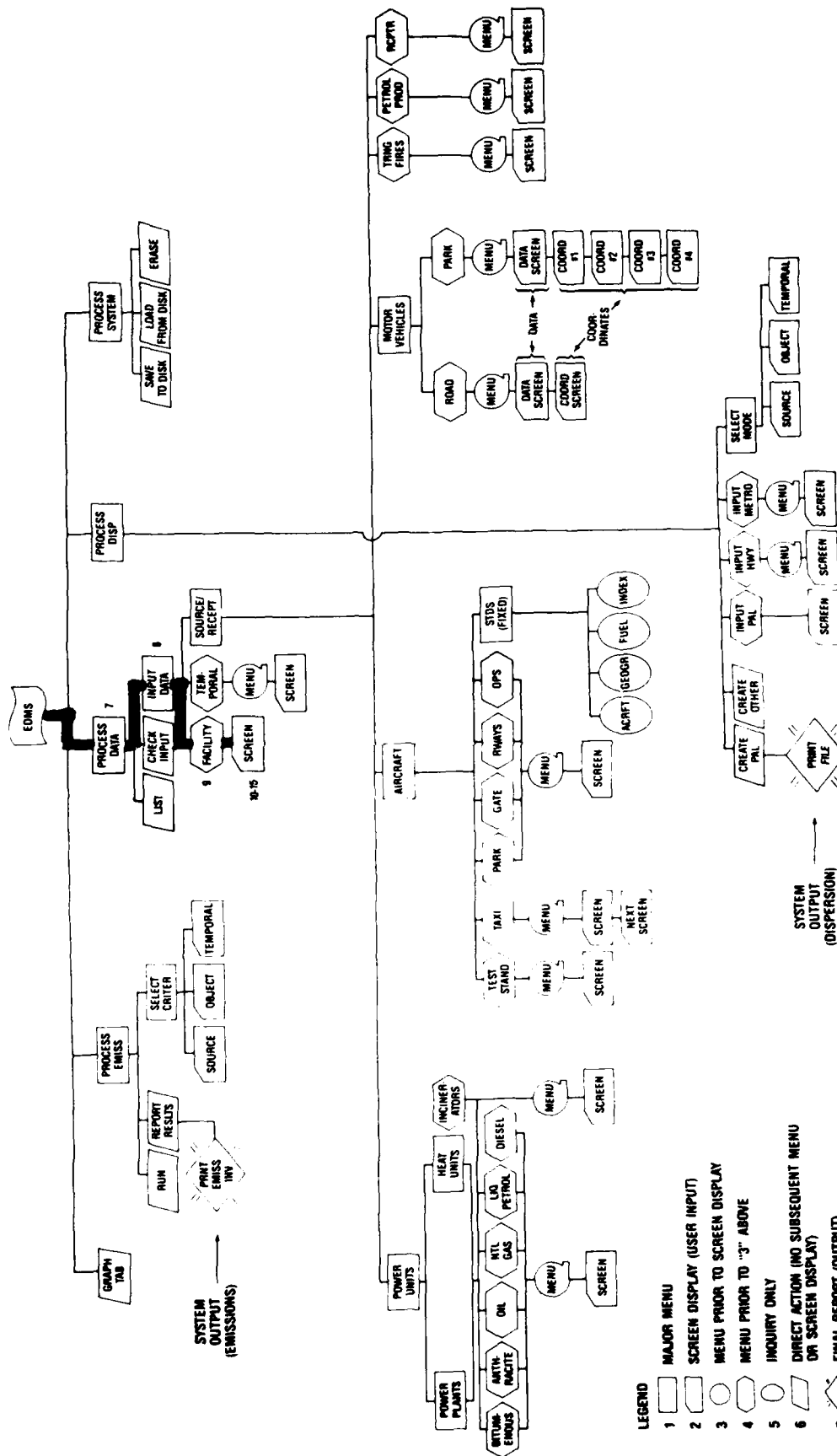

FIGURE V-3

V-5.1.2 ENTER FACILITY DATA (ITEM 1)  
(See Fig. V-3 for flow schematic.)

- |    |   |  |
|----|---|--|
| 9  | type "1" ENTER  | display airport facility screen (item 1).                            |
| 10 | type "R" -- NOTE: the character "R" was selected from the option line at the bottom of the screen   | activate revise mode prior to entering data                          |
| 11 | press ENTER six times   | move cursor to latitude field  |
| 12 | type 3851N ENTER  | enter latitude   |
| 13 | type 7702W ENTER  | enter longitude  |
| 14 | press ENTER thirteen times - NOTE: after passing through the last field (DEC 70) the select line at the bottom of the screen changes to the "OPTION" mode | move cursor through the remaining fields without changing any values |
| 15 | type "P" then E"  | print and save data  |
| 16 | press ENTER   | return to main menu  |

# Menu Flow Temporal (Input Data)

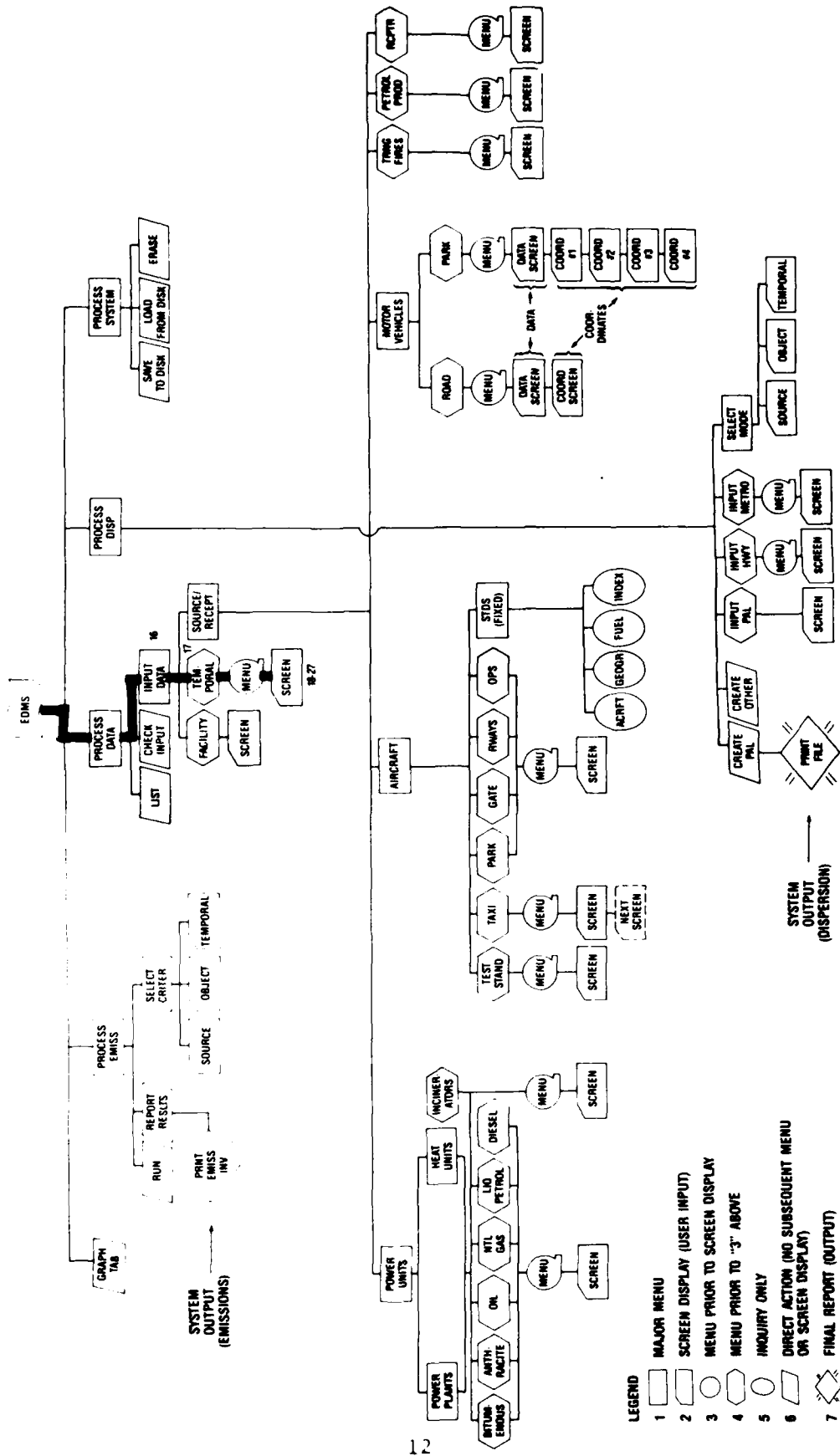

FIGURE V-4

5.1.3 ENTER TEMPORAL DATA (MENU ITEM 2)

(See Fig. V-4 for flow schematic)

- |    |  |  |
|----|--|--|
| 17 | type "2" ENTER   | select "TEMPORAL" item   |
| 18 | type "1" ENTER   | select "add new data" option   |
| 19 | type "POWER" ENTER   | enter file name  |
| 20 | type "1" ENTER 43 times  | enter "1.0" into all fields to show 100% activity at all times             |
| 21 | type "P" then "E"  | print and save temporal file named "POWER"                                 |
| 22 | type "1" ENTER   | display blank screen for second file                                       |
| 23 | type "SCENARIO" ENTER  | enter file name (SCENARIO)   |
| 24 | press ENTER 28 times   | enter defaults values (100%)   |
| 25 | type .9 ENTER; type .8 ENTER<br>type .6 ENTER; type .6 ENTER<br>type .9 ENTER; type .7 ENTER | enter appropriate temporal factors from Table V-1 into the next six fields |

TABLE V-1

TEMPORAL ACTIVITY

Object Number I		1 SRC.CD		0 TEMPORAL		SCENARIO	
Hour	Factor	Hour	Factor	Day	Factor	Month	Factor
0100	H1 0.00	1300	H13 0.00	M	D1 0.00	JAN	M1 0.00
0200	H2 0.00	1400	H14 0.00	T	D2 0.00	FEB	M2 0.00
0300	H3 0.00	1500	H15 0.00	W	D3 0.00	MAR	M3 0.00
0400	H4 0.00	1600	H16 0.00	Th	D4 0.00	APR	M4 0.00
0500	H5 0.00	1700	H17 0.00	F	D5 0.00	MAY	M5 0.00
0600	H6 0.00	1800	H18 0.00	Sa	D6 0.00	JUN	M6 0.00
0700	H7 0.00	1900	H19 0.00	Su	D7 0.00	JUL	M7 0.00
0800	H8 0.90	2000	H20 0.80			AUG	M8 0.60
0900	H9 0.60	2100	H21 0.90			SEP	M9 0.70
1000	H10 0.00	2200	H22 0.00			OCT	M10 0.00
1100	H11 0.00	2300	H23 0.00			NOV	M11 0.00
1200	H12 0.00	2400	H24 0.00			DEC	M12 0.00

- |    |                                  |                         |
|----|----------------------------------|-------------------------|
| 26 | press ENTER successively to exit | exit screen             |
| 27 | type "P" then "E"                | print then save         |
| 28 | type "10" ENTER                  | return to previous menu |

# Menu Flow Bitumemous Power Plants (Power Units)

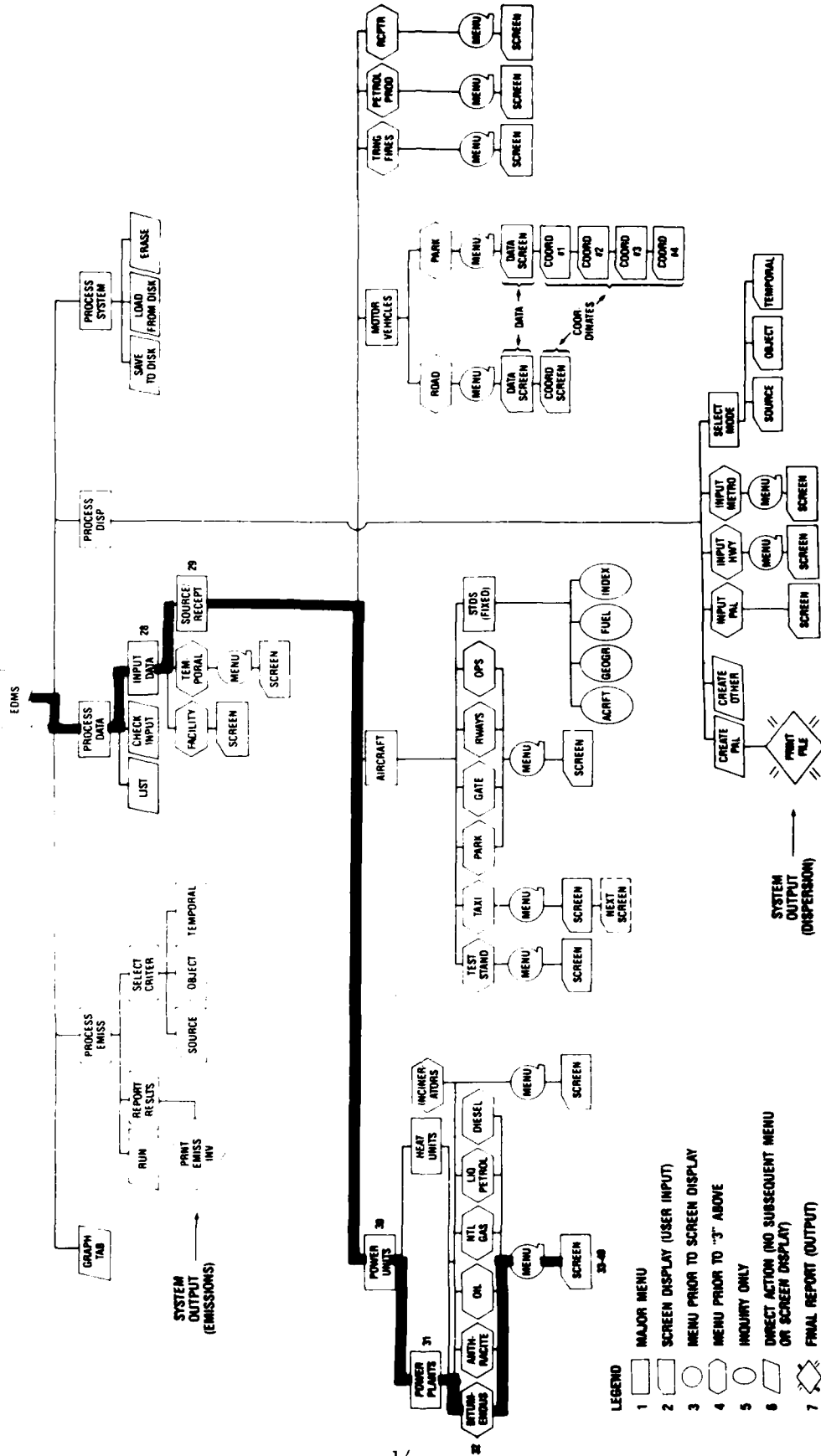

FIGURE V-5

V-5.1.4 ENTER SOURCE DATA - POWER PLANTS  
(See Fig. V-5 for flow schematics.)

29	type "3" ENTER	select "source input"
30	type "2" ENTER	select "power input"
31	type "1" ENTER	select "power plant"
32	type "1" ENTER	select "bituminous"
33	type "1" ENTER	display blank screen
34	type "POWER" ENTER	enter the relational name of the temporal file (POWER)
35	type "PUGET POWER #1" ENTER	enter the name of the power plant
36	type "800" ENTER type "400" ENTER	enter plant coordinates (meters from origin)
37	press ENTER seven times	enter defaults
38	type "4" ENTER	enter amount of fuel burned
39	press ENTER a sufficient number of times to pass through all fields	enter remaining defaults
40	type "P" then "E"	print and save data
41	type "10" ENTER type "10" ENTER type "10" ENTER	return to source menu

# Menu Flow Operations (Aircraft)

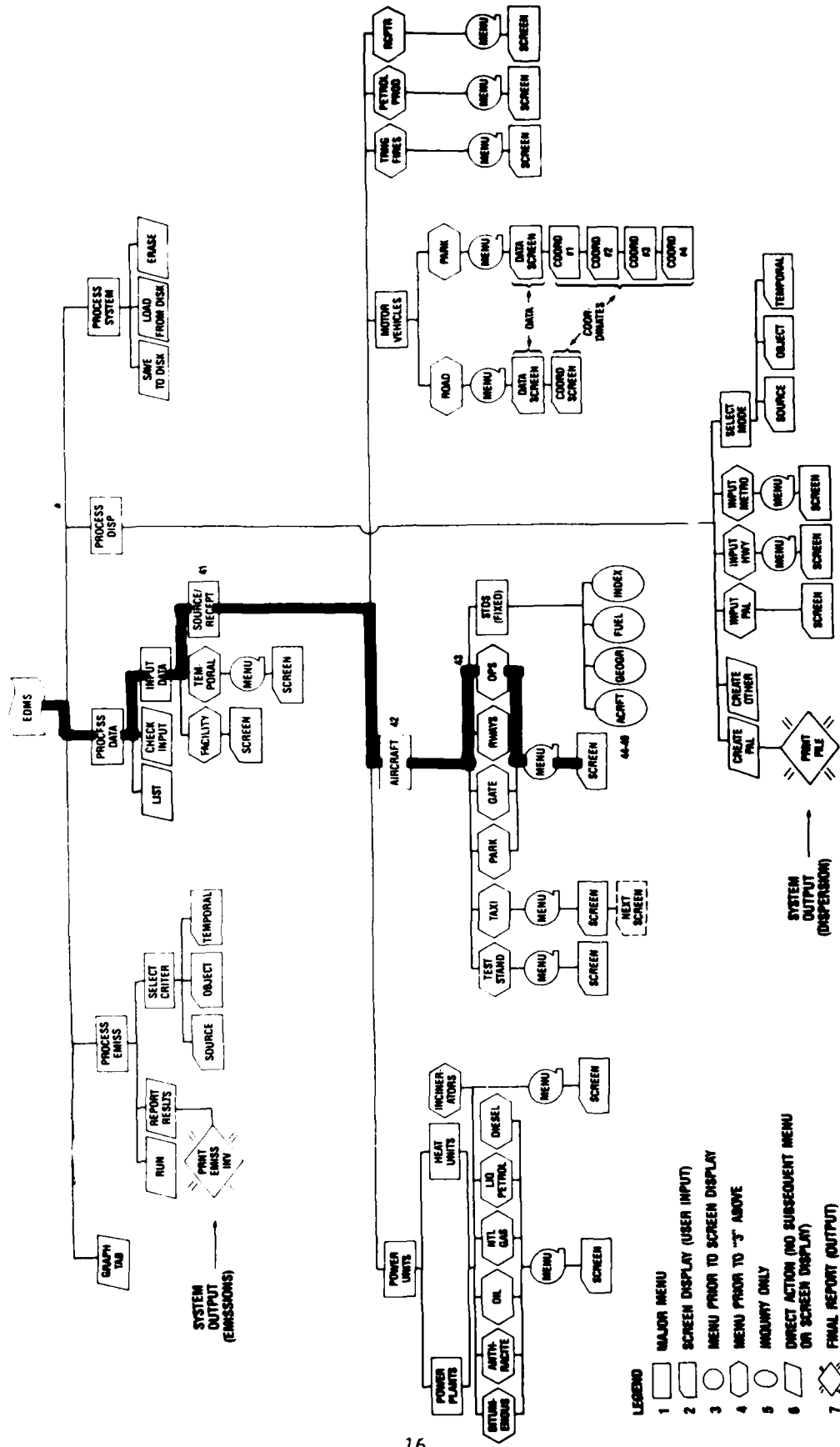

FIGURE V-6

V-5.1.5 ENTER SOURCE DATA - AIRCRAFT OPERATIONS

(See Fig. V-6 for flow schematics.)

- |    |  |  |
|----|--|--|
| 42 | type "4" ENTER   | select new source (aircraft)                                     |
| 43 | type "1" ENTER   | prepare to input aircraft type and their departures rates        |
| 44 | type "1" ENTER   | display screen for first aircraft                                |
| 45 | type "SCENARIO" ENTER<br>type "B737-17"<br>press ENTER three times<br>type "10"<br>press ENTER two times | enter 737 information for<br>10-737 departures per hour          |
| 46 | type "P then "E"   | print then save data   |
| 47 | type "1" ENTER   | display screen for next aircraft                                 |
| 48 | type "SCENARIO" ENTER<br>type "B727-17"<br>press ENTER three times<br>type "12"<br>press ENTER two times | enter second aircraft information<br>12-727s departures per hour |
| 49 | type "P" then "E"  | print then save this data  |
| 50 | type "10" ENTER  | return to aircraft menu  |

# Menu Flow Runway (Aircraft)

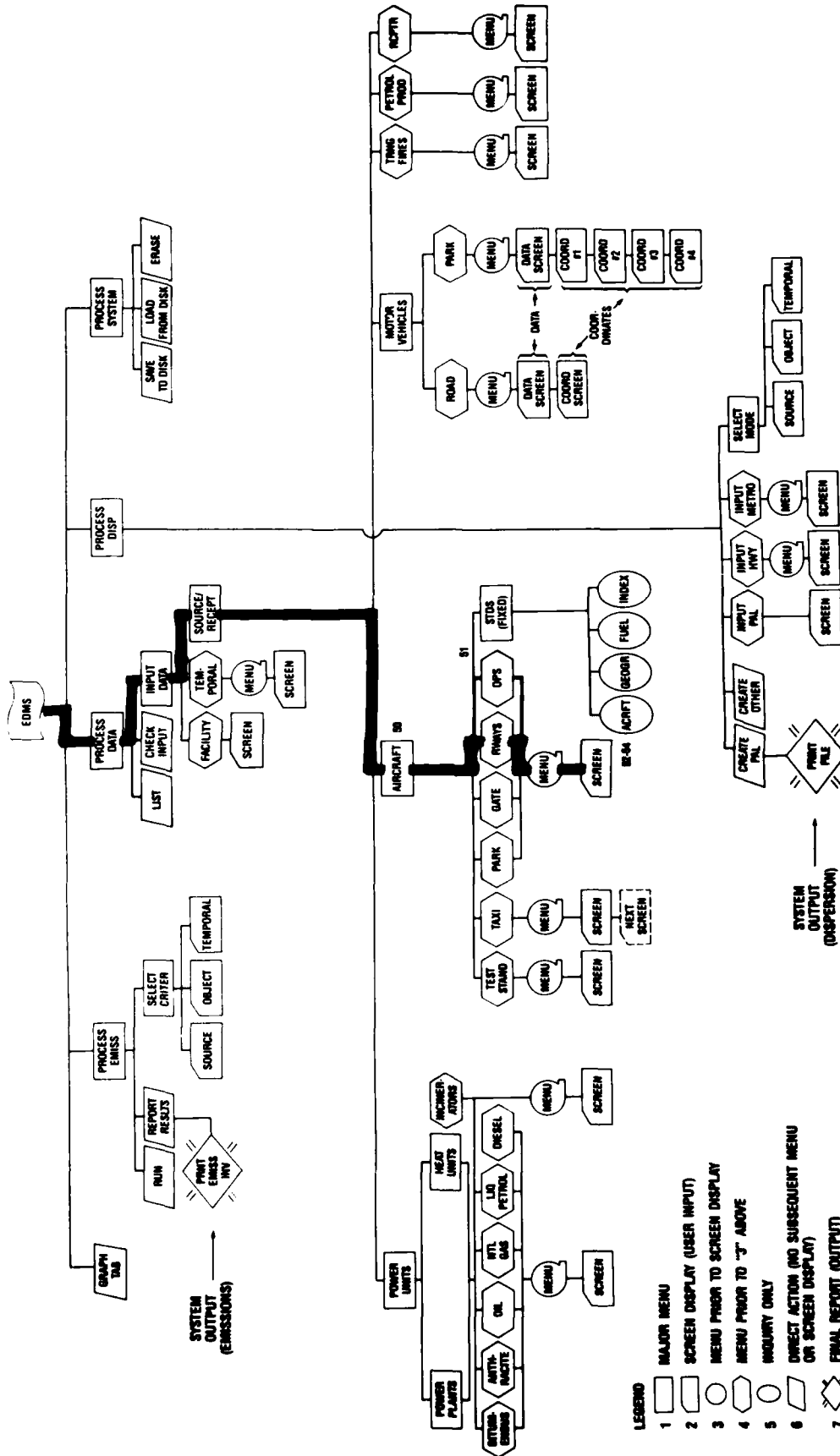

FIGURE V-7

V-5.1.6 ENTER SOURCE DATA (AIRCRAFT RUNWAY)  
 (See Fig. V-7 for flow schematics.)

- 51 type "2" ENTER select the runway option  
 52 type "1" ENTER display input screen  
 53 enter appropriate runway and runway queueing data from Table V-2 by moving cursor through the fields (enter name or value then move cursor to next field by pressing the ENTER key) enter runway and queueing data

TABLE V-2

RUNWAYS AND RUNWAY QUEUEING AREAS

Runway number R Name	DATA32	<u>1</u> Main	Object number I	370 SRC.CD 61	TEMPORAL	SCENARIO
Location:	Point 1 X1	<u>1550</u>	Y1	<u>1050</u>	Length LE	<u>1000</u> feet
	Point 2 X2	<u>0000</u>	Y2	<u>900</u>	Angle AN	<u>0</u> degrees
Runway queueing areas:						
Location:	Point 1 Q1X1	<u>1580</u>	Q1Y1	<u>1000</u>	Number in queue A1Q	<u>3</u>
	Point 2 Q1X2	<u>1500</u>	Q1Y2	<u>820</u>		
Location:	Point 1 Q2X1		Q2Y1		Number in queue A2Q	<u>0</u>
	Point 2 Q2X2		Q2Y2		Queueing area GEOMODE	<u>2</u>
Serviced aircraft:	SA1 <u>B737-17</u>		SA2 <u>B727-17</u>		SA3	SA4
Restricted aircraft:	RA1		RA2		RA3	RA4
Touch and go (0 no, 1 yes)			TGO	<u>0</u>	Touch and go Climb/apprch	GEOMODE <u>7</u> GEOMODE <u>8</u>

- 54 type "P" then "E" print and save data  
 55 type "10" ENTER return to main aircraft menu

# Menu Flow Taxi (Aircraft)

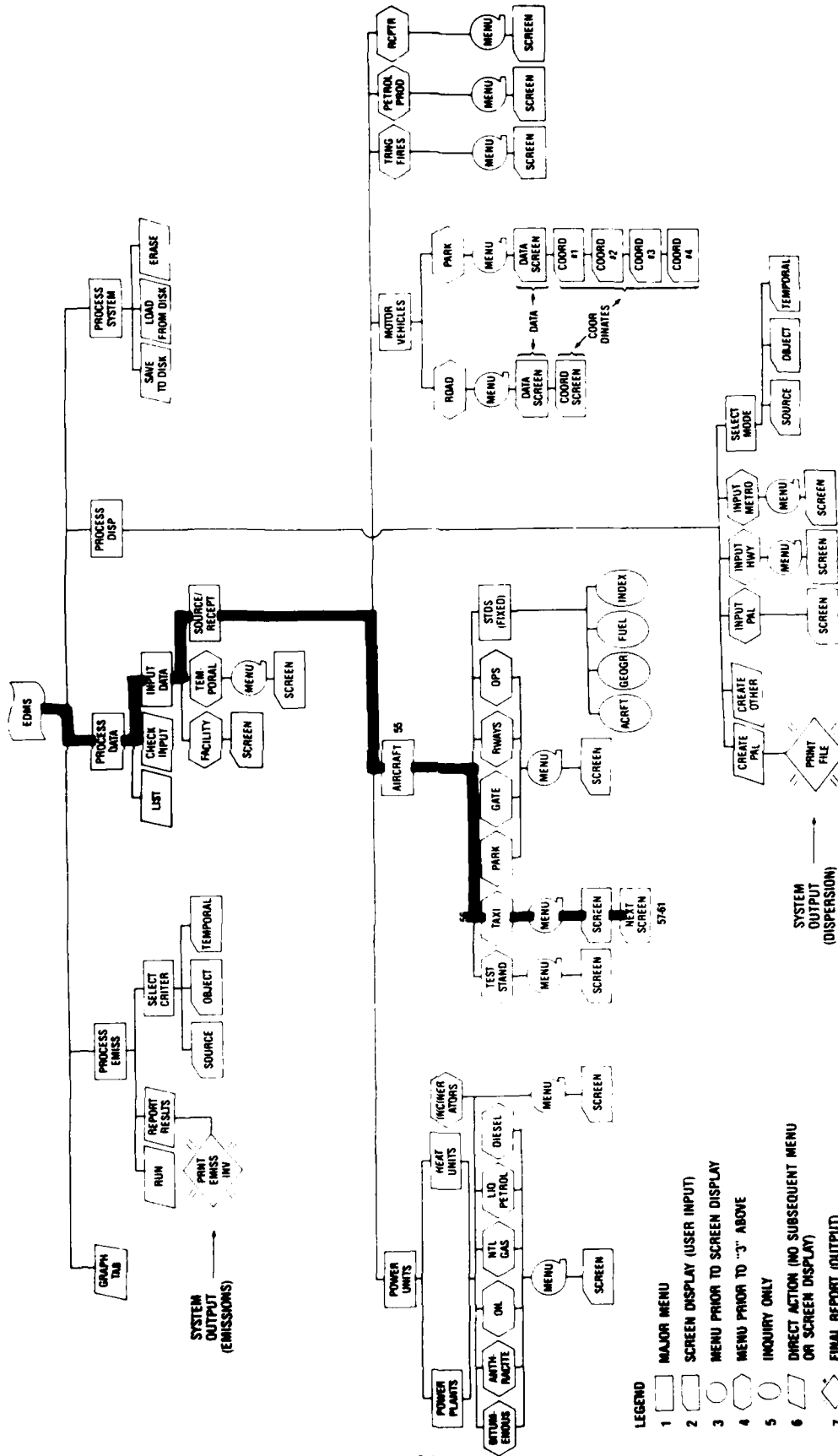

FIGURE V-8

V-5.1.7 ENTER SOURCE DATA (AIRCRAFT TAXI)  
 (See Fig. V-8 for flow schematics.)

- 56 type "3" ENTER                      select taxiway menu
- 57 type "1" ENTER                      display screen
- 58 move cursor through the fields      enter taxiway data  
 and input data from Table V-3  
 in accordance with past instruc-  
 tional information on cursor  
 movement and data entry

TABLE V-3						
AIRCRAFT TAXIWAYS						
Object number I 371 SRC.CD 62 TEMPORAL <u>SCENARIO</u>						
Taxiway number T <u>1</u>						
Name:        DATA32 <u>MAIN</u>						
Servicing runways:						
R1	<u>1</u>	R2	R3	R4	R5	
R6		R7	R8	R9	R0	
Servicing gates:						
G1	<u>1</u>	G2	G3	G4	G5	
G6		G7	G8	G9	G0	
GEOMODE 4						

- 59 type "P" then "E"                      print and save data
- 60 enter coordinates listed in          enter taxiway segment coordinates  
 Table V-4

NOTE: Taxiway coordinates were obtained from map in Fig. V-1. If a graphics tablet were available, these coordinates plus all subsequent coordinates, would be entered with the graphics tablet pen.

TABLE V-4					
TAXIWAY SEGMENTS					
Segment number:        J <u>1</u>					
Location: Point 1    X1 <u>1100</u> Y1 <u>740</u>					
Point 2    X2 <u>1500</u> Y2 <u>820</u>					

- 61 type "P" then "E"                      print and save data
- 62 type "10" ENTER                      return to aircraft menu

# Menu Flow Gate (Aircraft)

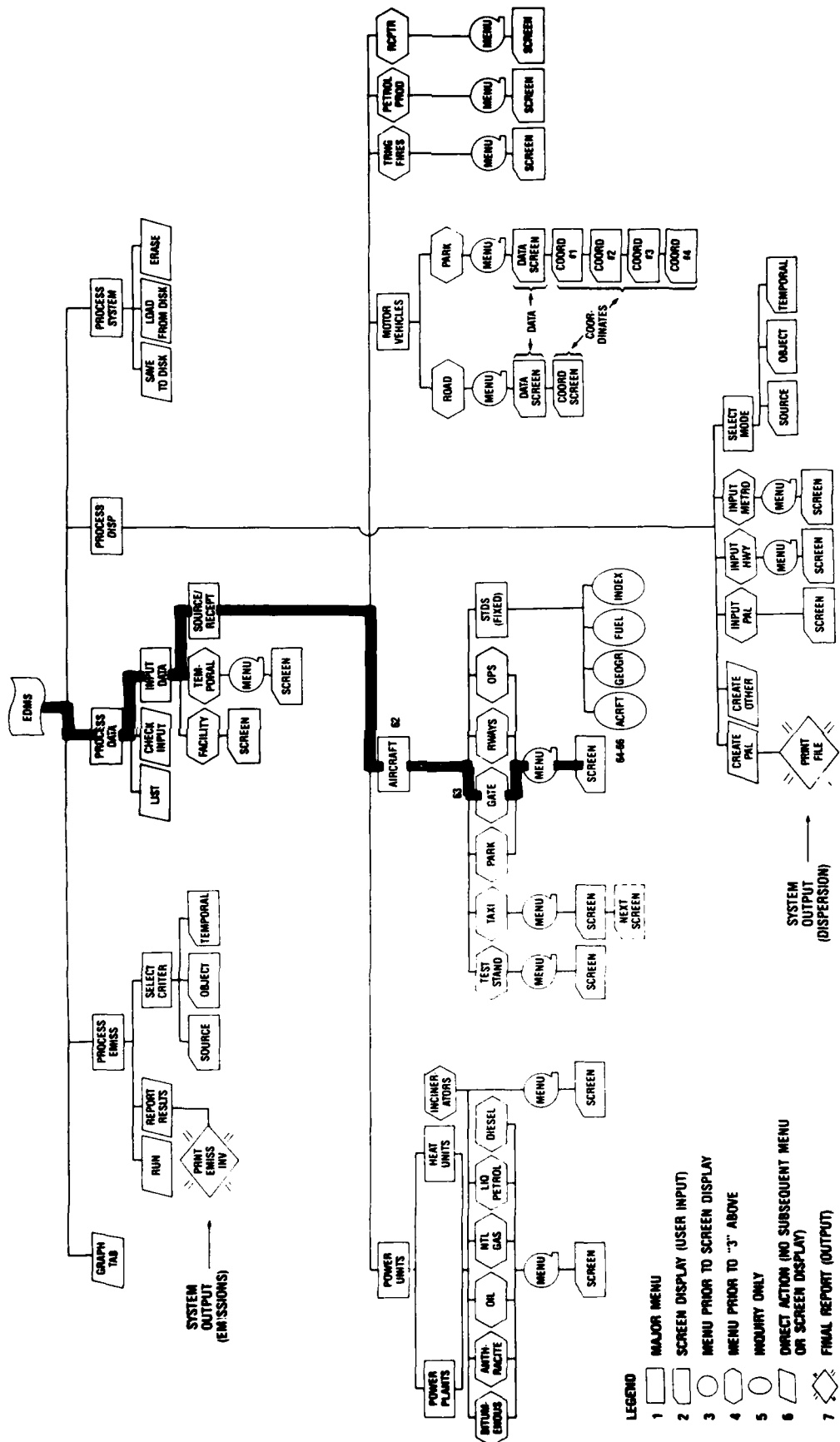
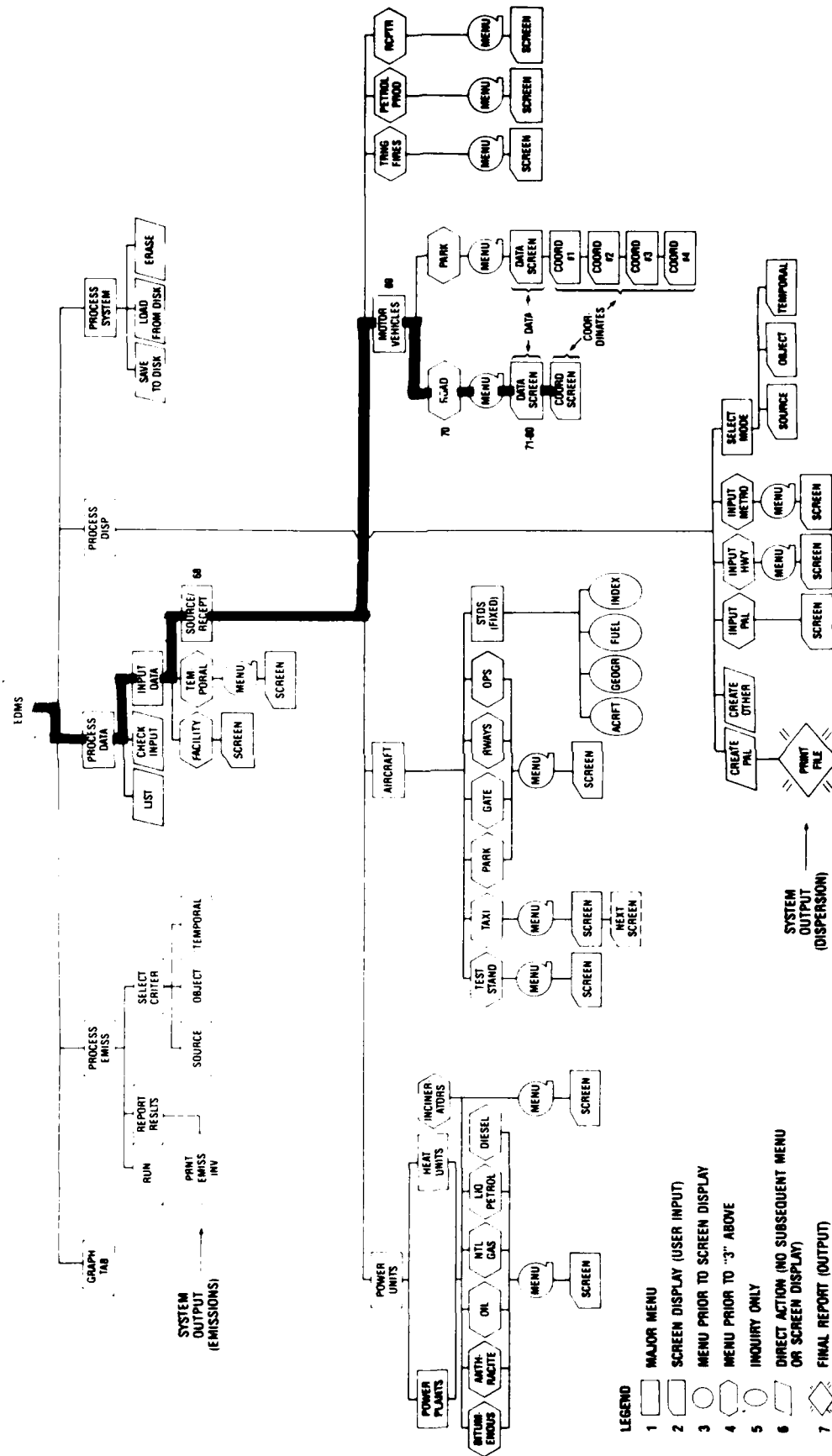

FIGURE V-9



# Menu Flow Roadways (Motor Vehicles)



V-5.1.9 ENTER SOURCE DATA - AUTO ROADWAYS  
 (See Fig. V-10 for flow schematics.)

- 69 type "5" ENTER                   select motor vehicle source
- 70 type "1" ENTER                   select roadway mode
- 71 type "1" ENTER                   display data screen for roadway
- 72 move cursor through fields       enter data for first roadway  
     filling in data per Table V-6

TABLE V-6

ROADWAY NUMBER 1 (DATA)

	Object number I	TEMPORAL	SCENARIO
Roadway name: DATA 32	<u>NORTH TERMINAL</u>		
Number of LANES:		<u>2</u>	
Length in MILES:		<u>0.30</u>	
Number of SEGMS:		<u>1</u>	
Baseline hourly vehicle activity:		Civilian	Military
Automobiles	V1	<u>1</u> CAUT	<u>340</u> MAUT
Trucks, gasoline			
Light (less than 6,000 lbs.)	V2	<u>2</u> CTGL	<u>0</u> MTGL
Medium (6,000 to 16,000 lbs.)	V3	<u>3</u> CTGM	<u>0</u> MTGM
Heavy (over 16,000 lbs.)	V4	<u>4</u> CTGH	<u>0</u> MTGH
Trucks, diesel, all	V5	<u>5</u> CTDS	<u>0</u> MTDS
Vehicle average speed		CVAS	<u>15.00</u> MVAS
Percent cold starts		CCLD	<u>20.00</u> MCLD
Percent hot soaks		CHOT	<u>00.00</u> MHOT

73 type "P" then "E"

print and save roadway data  
 (coordinates come next)

74 from Table V-7 fill in the coordinate screen for the first roadway

enter coordinates of first roadway

TABLE V-7					
ROADWAY NUMBER 1 (SEGMENT)					
Sement number:		J	<u>1</u>		
Location:	Point 1	X1	<u>320</u>	Y1	<u>500</u>
	Point 2	X2	<u>770</u>	Y2	<u>660</u>

75 type "P" then "E"

print and save data and coordinates for the first roadway

76 type "I" ENTER

display screen for second roadway

77 move cursor to enter data per Table V-8

enter data for second roadway

TABLE V-8						
ROADWAY NUMBER 2 (DATA)						
Object number I		374 SRC.CD 71 TEMPORAL <u>SCENARIO</u>				
Roadway name:	DATA 32 <u>MAIN TERMINAL</u>					
Number of LANES:	4.00					
Length in MILES:	<u>0.10</u>					
Number of SEGMS:	<u>1.00</u>					
Baseline hourly vehicle activity:				Civilian	Military	
Automobiles	V1	<u>1</u>	CAUT	<u>1500</u>	MAUT	<u>0</u>
Trucks, gasoline						
Light (less than 6,000 lbs.)	V2	<u>2</u>	CTGL	<u>0</u>	MTGL	<u>0</u>
Medium (6,000 to 16,000 lbs.)	V3	<u>3</u>	CTGM	<u>0</u>	MTGM	<u>0</u>
Heavy (over 16,000 lbs.)	V4	<u>4</u>	CTGH	<u>0</u>	MTGH	<u>0</u>
Trucks, diesel, all	V5	<u>5</u>	CTDS	<u>0</u>	MTDS	<u>0</u>
Vehicle average speed			CVAS	<u>5.00</u>	MVAS	<u>0.00</u>
Percent cold starts			CCLD	<u>20.00</u>	MCLD	<u>0.00</u>
Percent hot soaks			CHOT	<u>0.00</u>	MHOT	<u>0.00</u>

78 type "P" then "E"

print and save data for roadway #2

79 enter coordinates per  
Table V-9

enter coordinates for road #2

TABLE V-9

ROADWAY NUMBER 2 (SEGMENT)

Object number I 374 SRC.CD 71

Segment number:	J		<u>1</u>		
Location:	Point 1	X1	<u>880</u>	Y1	<u>530</u>
	Point 2	X2	<u>910</u>	Y2	<u>610</u>

80 type P then E

print and save coordinates for  
roadway #2

81 type "10" ENTER

return to motor vehicle menu

# Menu Flow Parking Lots (Motor Vehicles)

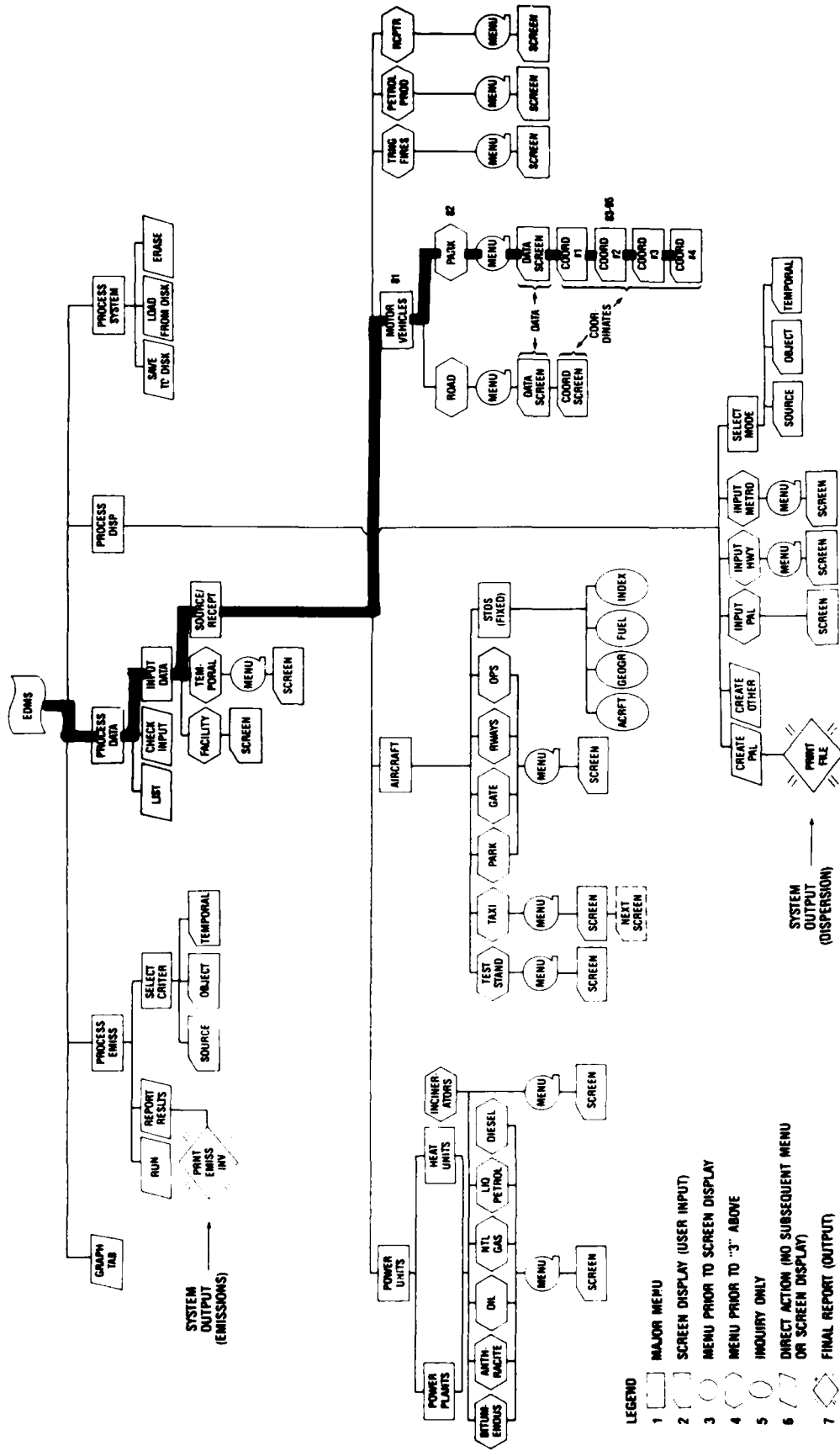

FIGURE V-11

V-5.1.10 ENTER SOURCE DATA - AUTO PARKING  
 (See Fig. V-11 for flow schematics.)

- 82 type "3" ENTER                      select parking lot option
- 83 type "1" ENTER                     display parking lot screen
- 84 fill in parking lot screen        enter parking lot data--(data first  
 per Table V-10                      then coordinates of the four corners  
    of the lot)

TABLE V-10	
VEHICLE PARKING FACILITIES (DATA)	
375 SCR.CD 75 TEMPORAL <u>SCENARIO</u>	
Parking facility DATA32 <u>MAIN TERMINAL LOT</u>	
Number of SPACES:	<u>100</u>
Number of gates ENTRY:	<u>1</u>
Number of gates EXITS:	<u>1</u>
Maximum distance MAXD from gate to park (feet)	<u>300.00</u>
Baseline hourly vehicle activity:	
Vehicle entering	VINP <u>150</u>
Vehicle exiting	VOUT <u>150</u>
Vehicle average speed	CVAS <u>5.00</u>
Percent cold starts on exit	CCLD <u>80.00</u>
Percent hot soaks on entry	CHOT <u>80.00</u>
Vehicle class	VCLS <u>1</u>

- 85 type "P" then "E"                      print and save parking lot data  
    (parking lot coordinates will be  
    added next)
- 86 type "1" ENTER                      enter coordinates of 1st of four  
     type "870" ENTER                   parking lot corners  
     type "530" ENTER
- 87 type "P" only                        print coordinates of first corner  
     CAUTION: "C" (not "E") will  
     be typed next
- 88 type "C" (for continue)            display screen for the second corner



89	type "2" ENTER type "919" ENTER type "620" ENTER	enter coordinates for second corner
90	type "P" type "C"	print and save coordinates of corner #2; display screen for corner #3
91	type "3" ENTER type "828" ENTER type "660" ENTER	enter coordinates of corner #3
92	type "P" type "C"	print and save coordinates of corner #3 display screen for corner #4
93	type "4" ENTER type "780" ENTER type "580" ENTER	enter coordinates for corner #4
94	type "P"	print coordinates of corner #4
95	type "E"	save entire parking lot entries which include data for the lot itself as well as the coordinates of its 4 corners
96	type "10" ENTER	return to motor vehicle
97	type "10" ENTER	return to source-receptor menu

# Menu Flow Receptors (Source/Receptor)

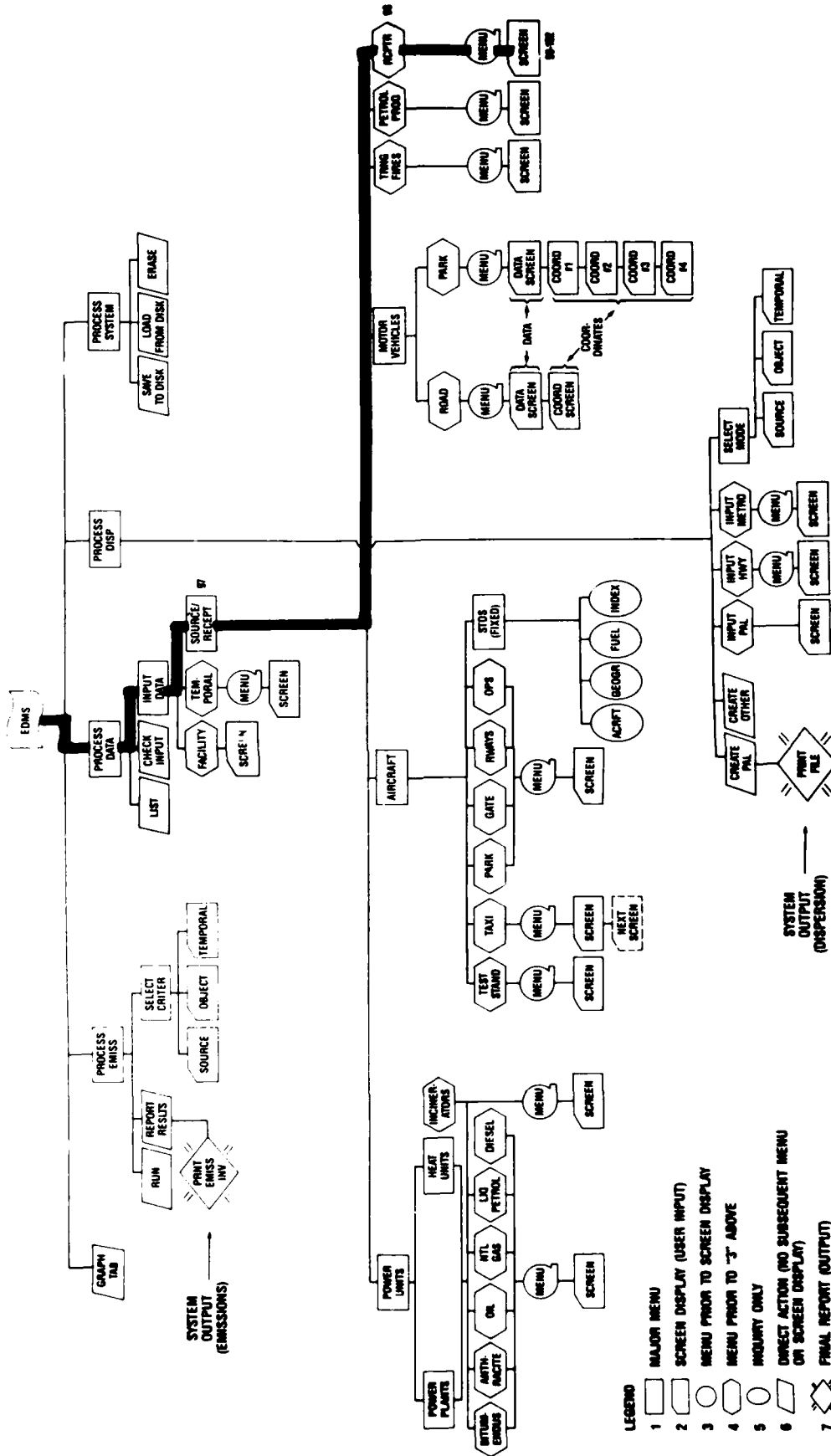

FIGURE V-12

V-5.1.11 ENTER RECEPTORS  
 (See Fig. V-12 for flow schematics.)

- 98 type "6" ENTER                    prepare to enter receptor coordinates
- 99 type "1" ENTER                    display receptor screen
- 100 move cursor through fields to    enter name and coordinates of  
       enter relevant data from      1st receptor  
       Table V-11

TABLE V-11				
RECEPTOR NO. 1				
Receptor number	J			<u>1</u>
Name	DATA32	<u>NORTH TERMINAL</u>		
Location	X	<u>540</u>	Y	<u>610</u>
RECEPTOR NO. 2				
Receptor number	J			<u>2</u>
Name	DATA32	<u>NORTH TERMINAL - MAIN</u>		
Location	X	<u>730</u>	Y	<u>690</u>
RECEPTOR NO. 3				
Receptor number	J			<u>3</u>
Name	DATA32	<u>MAIN TERMINAL</u>		
Location	X	<u>959</u>	Y	<u>600</u>
RECEPTOR NO. 4				
Receptor number	J			<u>4</u>
Name	DATA32	<u>FIELD</u>		
Location	X	<u>1620</u>	Y	<u>910</u>
RECEPTOR NO. 5				
Receptor number	J			<u>5</u>
Name	DATA32	<u>TAKEOFF</u>		
Location	X	<u>1650</u>	Y	<u>1100</u>

- 101 type "P" then "E"                print and save coordinates of 1st  
     receptor
- 102 repeat steps 99 thru 101 four    enter, print and save coordinates  
       times in order to enter the    of receptors 2, 3, 4 and 5; return  
       coordinates of receptors 2, 3,    to main menu  
       4 and 5; then type "11" ENTER

### Source-Receptor Geometry at Wash. National Airport

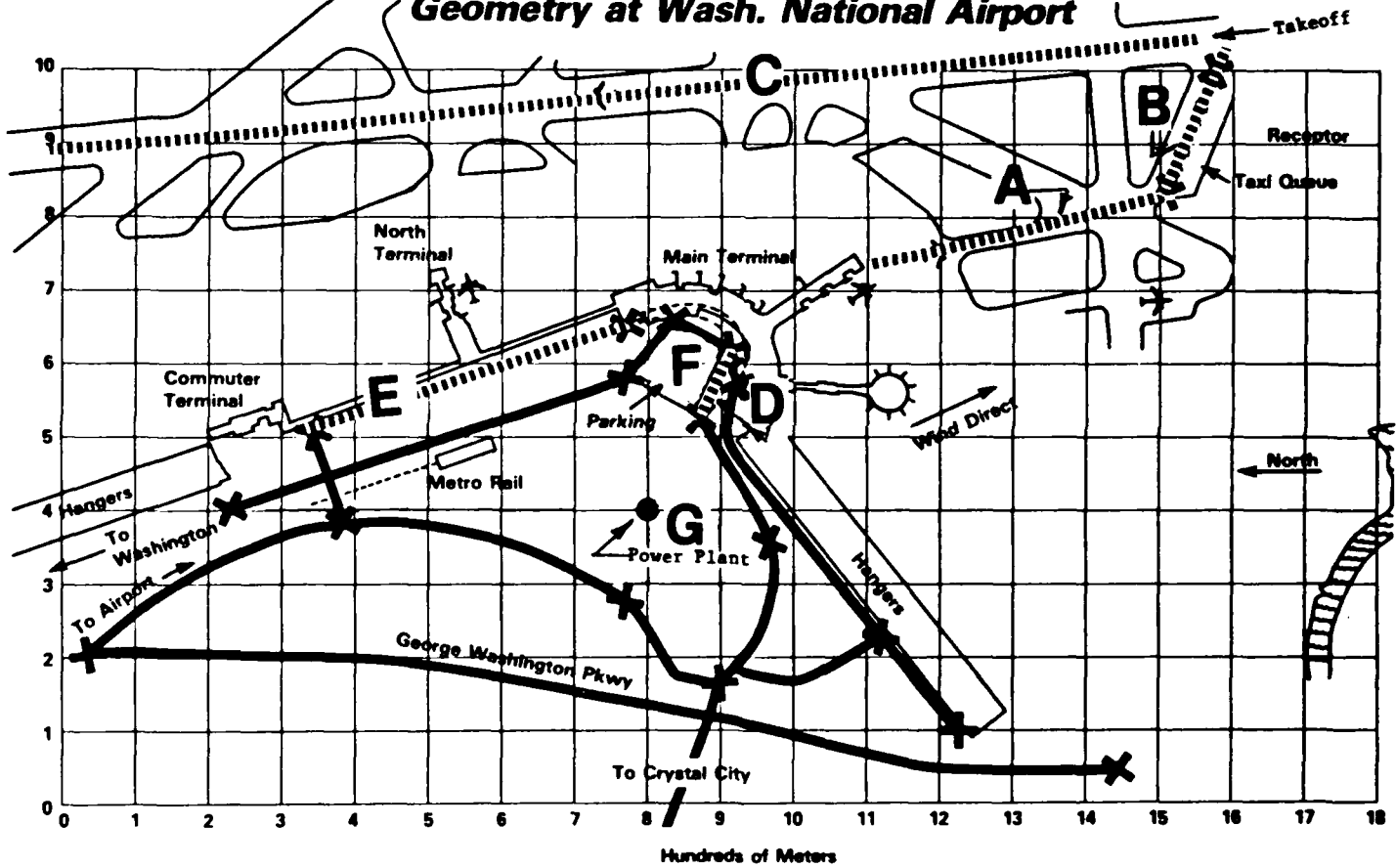

FIGURE V-1

All emissions and receptor data are now entered. The remaining tasks are to:

1. select the sources to run in the emissions model;
2. check to insure that all data has been entered correctly;
3. run emissions model;
4. print out results;
5. enter meteorological data for the dispersion model;
6. run model to create dispersion input file for PAL;
7. print out results;
8. save all these data on a separate diskette
9. erase all data from hard disk to prepare system to accept new scenario

# Menu Flow Run Emissions Model - Select Check Print

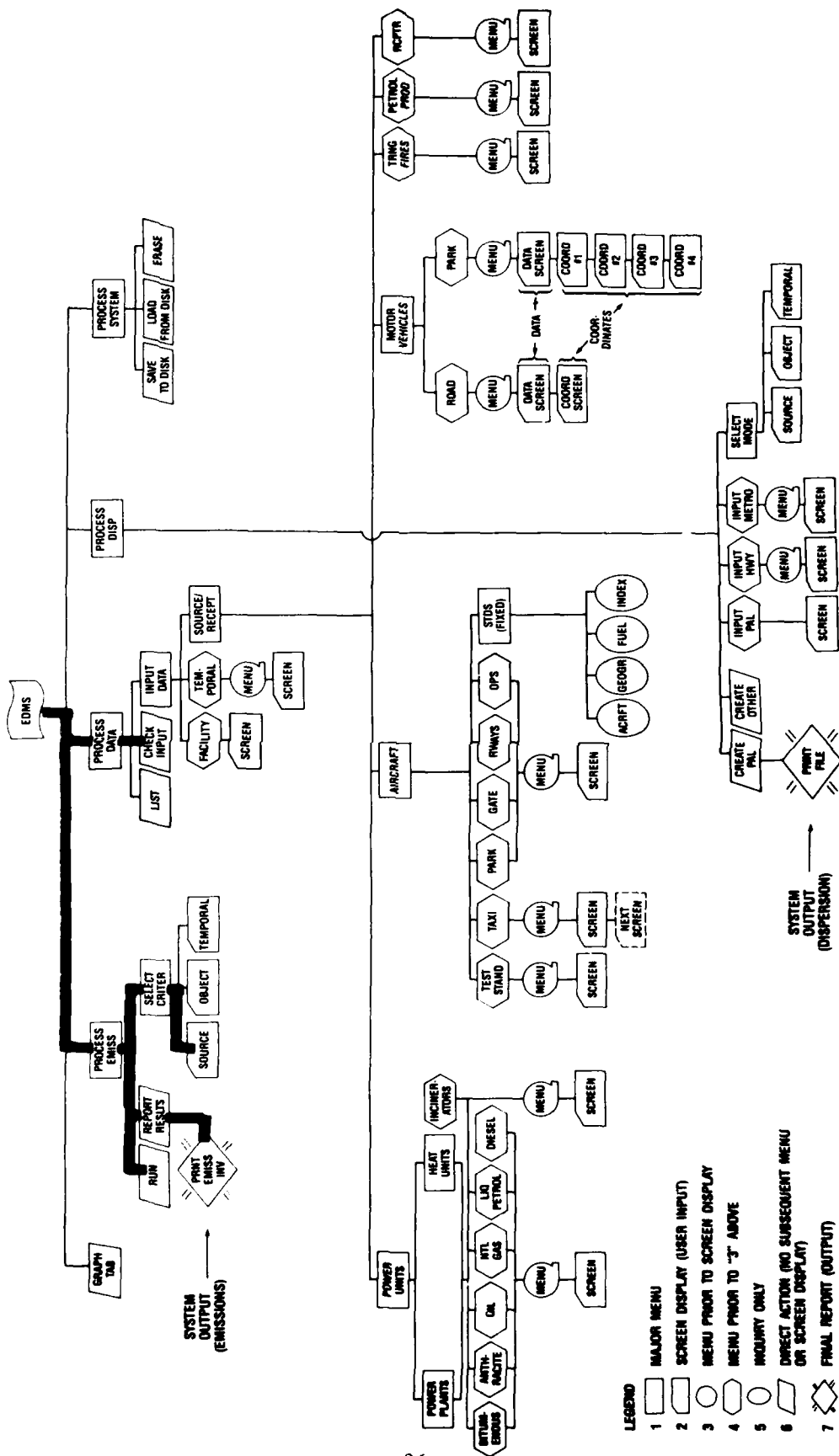

FIGURE V-13

V-5.1.12 RUN EMISSIONS - SELECT RUN CRITERION  
(See Fig. V-13 for flow schematics.)

- |   |                                  |
|---|----------------------------------|
| 104 type "3" ENTER  | initiate emissions model run     |
| 105 type "1" ENTER  | select source criterion          |
| 106 type "1" ENTER  | select source category criterion |
| 107 type "R"  | set data entry at "REVISE"       |
| 108 enter number 1 into the first field (process all sources) and press ENTER successively to enter zeros into the remaining fields | select "process all sources"     |
| 109 type "P" then "E" then ENTER  | print and save selection screen  |
| 110 type "11" ENTER   | return to main menu              |

V-5.1.13 RUN EMISSIONS - PRINT RESULTS  
(See Fig. V-13 for system schematics.)

- |   |                               |
|---|-------------------------------|
| 111 type "2" ENTER  | initiate emission data check  |
| 112 type "2" ENTER - this task will take about 15 minutes | select emissions check option |

NOTE: If you have made no errors in entering data, the main menu will be displayed and the printer will not print out any errors. When this happens, proceed to step 113 (run emissions model). If errors have been printed out they must be corrected. First identify the flow path to the screen requiring correction. Use the appropriate flow schematic (Figs. 1 - 14). Then using the knowledge you have already gained, select the menu screen just prior to the screen you wish to change. Type "2" ENTER and make the appropriate changes. Reenter the step sequence at step 110.

V-5.1.14 RUN EMISSIONS INPUT AND PRINT RESULTS  
(See Fig. V-13 for flow schematics.)

- |                    |   |
|--------------------|---|
| 113 type "4" ENTER | run emissions model                     |
| type "3" ENTER     |   |
| type "2" ENTER     |   |
| 114 type "3" ENTER | print out results of emission model run |

# Menu Flow Process Dispersion - Process System

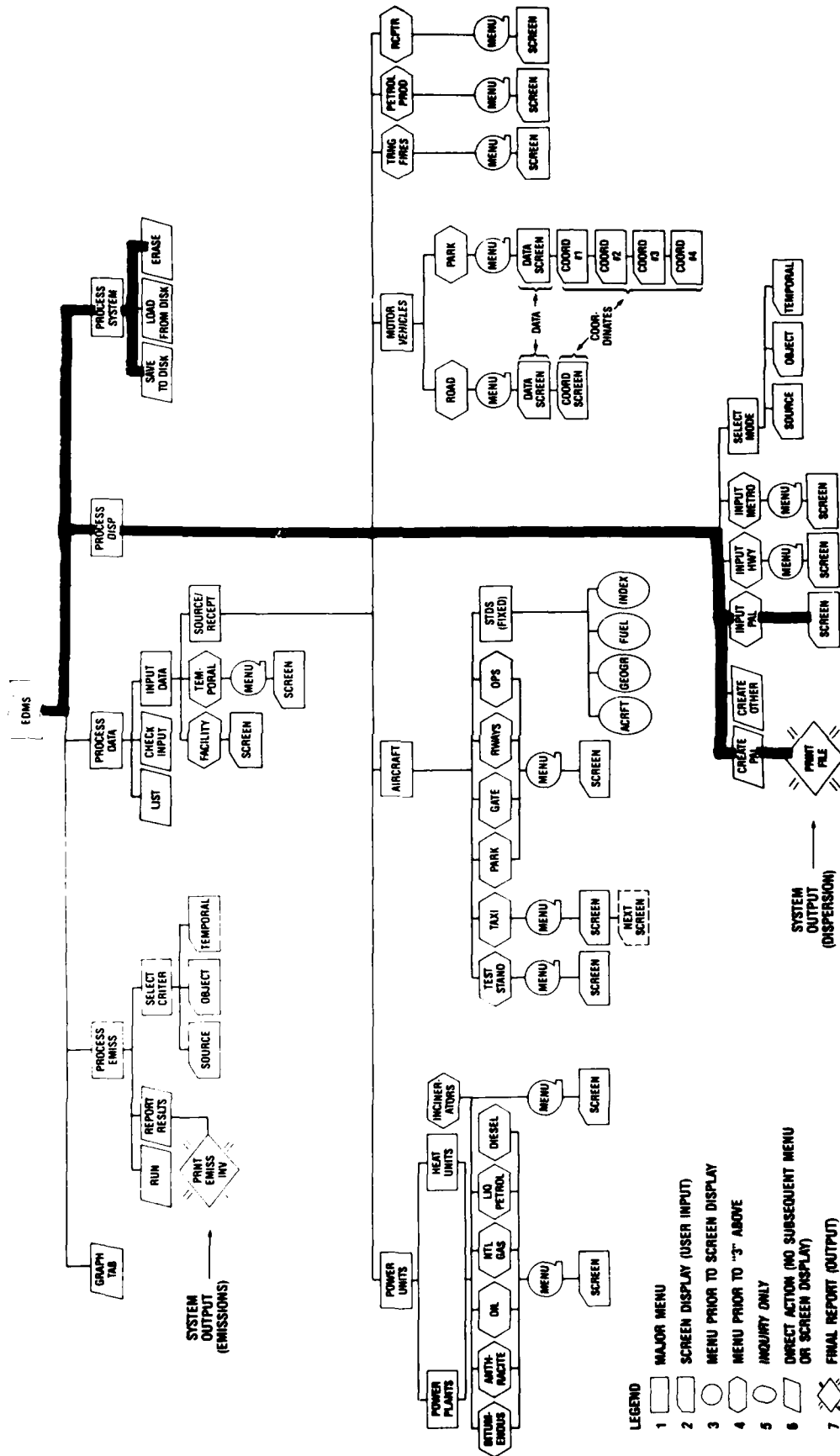

FIGURE V-14

V-5.1.15 PROCESS DISPERSION - INPUT METEOROLOGY  
(See Figure V-14 for flow schematics.)

- |   |  |
|---|--|
| 115 type "4" ENTER  | return to main menu  |
| 116 type "4" ENTER  | select the dispersion model option                               |
| 117 type "3" ENTER<br>type "N" 17 times   | select meteorological input option<br>sequence hour # to 1700    |
| 118 type "R"  | initiate revise mode   |
| 119 sequence cursor to enter the<br>following data:<br>month = 8<br>day = 6<br>pollutant = 1<br>temperature = 75<br>wind speed = 2<br>wind dir. = 145<br>degrees of change = 0<br>stability = 4 | enter meteorological data  |
| 120 type "P" then "E"   | print and save meteorological data.<br>return to dispersion menu |

NOTE: When you enter the wind direction value of 145 you will first have to backspace the cursor to the extreme left of the wind direction field to completely overwrite the default value. This backspace procedure is required whenever the "revise" mode is activated anywhere in the system.

V-5.1.16 PROCESS DISPERSION - MAKE AND PRINT PAL FILE  
(See Fig. V-14 for flow schematics.)

- |   |                                     |
|---|-------------------------------------|
| 121 type "4" ENTER; after red light<br>goes out, type "5" ENTER | create and print out PAL input deck |
| 122 type "11" ENTER   | return to main menu                 |

V-5.1.17 SAVE AND ERASE DATA  
(See Fig. V-14 for flow schematics.)

- |   |  |
|---|--|
| 123 type "5" ENTER  | select save menu option  |
| 124 insert formatted diskette into<br>the "A" drive; type "1" ENTER | save data on diskette  |
| 125 type "2" ENTER  | erase saved scenario from hard disk<br>This action clears the hard disk to<br>accept new data. |

## V-5.2 INSTRUCTIONS - GRAPHICS TABLET ON

To run the example problem with the graphics tablet on, make the following changes to the tablet-off step procedures (see section 5.1) and rerun the 125 steps.

1. Type "EDMSTON" rather than "EDMSTOFF" in step 6
2. Insert the following sequence between steps 6 and 7
  - 6.a type "7" RETURN                   display calibration help screen  
type "2" RETURN                   prior to calibrating the tablet;  
                                      Return to main menu
  - 6.b type "1" RETURN                   start tablet calibration  
type "C" RETURN  
type "K" RETURN  
type "1" RETURN
  - 6.c using tablet pen follow screen   complete calibration with cursor  
instructions; Enter line  
length of 1 kilometer (press  
pen button briskly)
  - 6.d type "Y" RETURN                   accept data as being correct

After completing step 6.d reenter the example problem at step 7. All coordinates will now be entered via the graphics tablet pen rather than the keyboard. Screen display instructions should now preempt text instructions when entering coordinates. The screen rather than the example problem text will now be the appropriate instructional tool for entering coordinate data.

## REFERENCES

1. D. M. Rote and L. E. Wangen, A Generalized Air Quality Assessment Model for Air Force Operations"; Air Force Weapons Laboratory, Kirkland Air Force Base, New Mexico; USAF Report #AFWL -TR -74 -304, Feb. 1975
2. Federal Aviation Administration, Airport Vicinity Air Pollution Model User's Guide"; FAA report FAA-RD-75-230; December 1975
3. Federal Aviation Administration, Simplex "A" - A Simplified Atmospheric Dispersion Model For Airport Use (User's Guide); FAA Report FAA-EE-81-8, July 1981;
4. H. M. Segal; "Microcomputer Graphics In Atmospheric Dispersion Modeling"; Journal of the Air Pollution Control Association; 23:6; June 1983
5. W. B. Peterson; User's Guide for PAL - A Gaussian-Plume Algorithm for Point, Area and Line Sources; Environmental Protection Agency; Research Triangle Park, N.C.; EPA-600/4-78-103; February 1978
6. W. B. Peterson; User's Guide for HIWAY-2, A Highway Air Pollution Model; Environmental Protection Agency, Research Triangle Park, N.C.; EPA-600/8-80-018; May 1980
7. U. S. Environmental Protection Agency; User's Manual for Single Source (CRSTER) Model, Environmental Protection Agency, Research Triangle Park, N.C.; EPA-450/2-77-013; 1977
8. Emissions and Dispersion Modeling System - Final Report; Wilson Hill Associates; 1220 L Street, N.W., Washington D.C.; 1985 (under preparation)
9. Condor 3 Database Management System - User's Guide, Condor Computer Corporation; P.O. Box 8318; Ann Arbor, MI.; 1983
10. Compilation of Air Pollution Emission Factors - AP-42 Supplements 8 through 14; Environmental Protection Agency; Research Triangle Park, N.C.; June 1982 - May 1983

(INTENTIONALLY BLANK)

## APPENDIX A

### PROCEDURES FOR CHANGING DATA FILES

#### 1. GENERAL

All data are entered into the system through the EDMS Condor database program. The CONDOR User's Guide (Reference 9) provides comprehensive instruction for the commands needed to update the CONDOR system. The following sets of commands may also be useful in changing a database within CONDOR. In this section, characters bracketted by quotes represent user input.

The following is a list of file names for the various standards files.

- FUEL - Fuel Standards
- TFEM - Training Fire Emission Factors
- PPEF - Heating/Power Plant Emission Factors
- INEF - Incinerators emission factors
- TNEF - Petroleum Products (Tanks) Emission Factors
- AIRC - Aircraft Type Standards
- AIRU - Aircraft Geographic Mode Standards
- AIRZ - Aircraft Emission Factors
- MVEM - Motor Vehicle Emission Factors

#### 1.1 UPDATING RECORDS

To update a standards database, type "DBMS" from the system prompt C >, then use the CONDOR UPDATE command with the following format:

```
C >> "UPDATE filename"
```

where "filename" is the name of the database file to be updated (see list above).

After changes have been made and saved, run the Standards program by typing:

```
C >> "RUN STANDARD.CMD"
```

#### 1.2 ADDING RECORDS

Adding records uses a slightly different format than updating records. The file must first be read from hard disk into random access memory (RAM). A new file is then defined on the hard disk to which records can be added.

After all records have been added, the original file is read from RAM and appended to the new file containing the new records. After the files have been combined, the standards program must be run to insert any needed standards into the data base. Be sure to back up the data base

immediately before using this type of ADP. If there is any power loss or spike or if the computer is reset for any reason, the file that was loaded into memory will be lost. Use the following commands to add records to a file:

- C >> "WRITE filename filename.TXT(M)"  
Writes file into RAM. "filename" should be the same for both files.
- C >> "ENTER filename"  
Opens file for input. "filename" must be the same as the first file name in the write command. New records are entered into this file using the data entry screen provided. Data entry is performed the same as entering data into the working inventory data base.
- C >> "READ filename filename.TXT(M)"  
Read original file from RAM and appends it to the newly created file. "filename" must be the same as those used in the first two commands. This command should only be used after all additions have been made.
- C >> "RUN STANDARD.CMD"  
Runs standards program to insert any needed standard information into the new records.

The following example shows how to add a new aircraft type into the standards database.

- C >> WRITE AIRC AIRC.TXT(M)
- C >> ENTER AIRC (Data entry screen (Figure B-1) will appear here. Enter new records.)
- C >> READ AIRC AIRC.TXT(M)
- C >> RUN STANDARD.CMD

Table A-1

AIRCRAFT DATA ENTRY SCREEN

A I R C R A F T

SRC.CD

AIRCLS \_\_\_\_\_  
AIRCFT \_\_\_\_\_  
DATA32 \_\_\_\_\_

## APPENDIX B

### MODEL VALIDATION

#### 1. EMISSIONS VALIDATION

Validation was performed by comparing emission values produced from EDMS (in grams per year) with those derived or extracted from:

1. Methods and constants provided by the EPA report, AP-42 (Reference 10)
2. American Petroleum Institute (API) listings
3. AQAM model listings

Of the three listings, AP-42 and API values were the most valid since they reflect recent data and are used routinely in environmental assessments for state or federal approval. The less current AQAM listing were used only when no other information was available.

Every source type included in EDMS was validated and the results are listed in Tables B-1 through B-4.

EDMS results were within 3% of the AP-42 and API criteria values and within 7% of the AQAM criterion in all cases considered.

#### 2. DISPERSION VALIDATION

The dispersion portion of the EDMS was validated by insuring that the values appearing in the input file for the PAL dispersion model were the same as those interactively entered by the user into the database.

The PAL input file created in the example model was correctly formatted and the values drawn from it were correctly assigned. This input file was then transferred via micromodem to a mainframe computer at the Computer Science Corporation (CSC) time-sharing center and run on a copy of PAL which had been loaded into the system. PAL then ran satisfactorily.

TABLE B-1  
VALIDATION RESULTS

TRAINING FIRES

MODEL	CO	HC	NOx	SOx	Particulates
EDMS	$2.95 \times 10^7$	$1.69 \times 10^7$	$2.19 \times 10^5$	$5.27 \times 10^4$	$6.74 \times 10^6$
AQAM	$2.95 \times 10^7$	$1.69 \times 10^7$	$2.19 \times 10^5$	$5.27 \times 10^4$	$6.74 \times 10^6$

TANK FARMS

MODEL	CO	HC	NOx	SOx	Particulates
EDMS	$0.00 \times 10^0$	$1.29 \times 10^6$	$0.00 \times 10^0$	$0.00 \times 10^0$	$0.00 \times 10^0$
API	$0.00 \times 10^0$	$1.27 \times 10^6$	$0.00 \times 10^0$	$0.00 \times 10^0$	$0.00 \times 10^0$

NATURAL GAS HEATING PLANT

MODEL	CO	HC	NOx	SOx	Particulates
EDMS	$1.09 \times 10^6$	$2.14 \times 10^5$	$5.44 \times 10^6$	$0.00 \times 10^0$	$1.63 \times 10^5$
AP-42	$1.09 \times 10^6$	$2.14 \times 10^5$	$5.44 \times 10^6$	$0.00 \times 10^0$	$1.63 \times 10^5$

FUEL OIL HEATING PLANT

MODEL	CO	HC	NOx	SOx	Particulates
EDMS	$1.23 \times 10^6$	$8.63 \times 10^5$	$1.78 \times 10^7$	$5.15 \times 10^7$	$6.78 \times 10^6$
AP-42	$1.23 \times 10^6$	$8.63 \times 10^5$	$1.78 \times 10^7$	$5.15 \times 10^7$	$6.78 \times 10^6$

TABLE B-2  
 VALIDATION RESULTS (CONT.)

INCINERATOR

MODEL	CO	HC	NOx	SOx	Particulates
EDMS	$2.03 \times 10^8$	$1.63 \times 10^7$	$2.44 \times 10^7$	$1.22 \times 10^7$	$6.50 \times 10^5$
AQAM	$2.03 \times 10^8$	$1.63 \times 10^7$	$2.44 \times 10^7$	$1.22 \times 10^7$	$6.50 \times 10^5$

AUTOMOBILES ON ROADWAY -- 100% COLD STARTED AT 5 MPH

MODEL	CO	HC	NOx	SOx	Particulates
EDMS	$5.76 \times 10^6$	$3.95 \times 10^5$	$3.00 \times 10^4$	$9.00 \times 10^1$	$3.11 \times 10^3$
AP-42	$5.76 \times 10^6$	$3.95 \times 10^5$	$3.00 \times 10^4$	$9.00 \times 10^1$	$3.11 \times 10^3$

AUTOMOBILES ON ROADWAY -- STABLIZED AT 30 MPH

MODEL	CO	HC	NOx	SOx	Particulates
EDMS	$6.93 \times 10^4$	$7.97 \times 10^3$	$9.47 \times 10^3$	$4.49 \times 10^1$	$1.56 \times 10^3$
AP-42	$6.93 \times 10^4$	$7.97 \times 10^3$	$9.47 \times 10^3$	$4.49 \times 10^1$	$1.56 \times 10^3$

AUTOMOBILES ON ROADWAY -- 20% COLD START AT 30 MPH

MODEL	CO	HC	NOx	SOx	Particulates
EDMS	$1.86 \times 10^5$	$1.60 \times 10^4$	$1.06 \times 10^4$	$4.58 \times 10^1$	$1.59 \times 10^3$
AP-42	$1.86 \times 10^5$	$1.60 \times 10^4$	$1.06 \times 10^4$	$4.58 \times 10^1$	$1.59 \times 10^3$

TABLE B-3

## VALIDATION RESULTS (CONT.)

## AUTOMOBILES ON ROADWAY -- 20% COLD START AT 30 MPH (SHORTER ROAD)

MODEL	CO	HC	NO <sub>x</sub>	SO <sub>x</sub>	Particulates
EDMS	$1.90 \times 10^4$	$1.63 \times 10^3$	$1.08 \times 10^3$	$4.67 \times 10^0$	$1.62 \times 10^2$
AP-42	$1.89 \times 10^4$	$1.66 \times 10^3$	$1.09 \times 10^3$	$4.58 \times 10^0$	$1.61 \times 10^2$

## AUTOMOBILE PARKING LOT

MODEL	CO	HC	NO <sub>x</sub>	SO <sub>x</sub>	Particulates
EDMS	$4.45 \times 10^3$	$1.70 \times 10^2$	$1.41 \times 10^1$	$4.94 \times 10^{-1}$	$1.71 \times 10^0$
AP-42	$4.45 \times 10^3$	$1.70 \times 10^2$	$1.41 \times 10^1$	$4.94 \times 10^{-1}$	$1.61 \times 10^0$

## AIRPLANES -- "TRANSENT (AQAM GENERIC TRANSIENT)

MODEL	CO	HC	NO <sub>x</sub>	SO <sub>x</sub>	Particulates
EDMS	$8.79 \times 10^7$	$1.74 \times 10^7$	$1.41 \times 10^7$	$1.49 \times 10^7$	$3.11 \times 10^6$
AQAM	$8.77 \times 10^7$	$2.57 \times 10^7$	$1.41 \times 10^7$	$1.41 \times 10^7$	$3.06 \times 10^6$
(FUELING)		$-8.34 \times 10^6$			
AQAM	$8.77 \times 10^7$	$1.74 \times 10^7$	$1.41 \times 10^7$	$1.41 \times 10^7$	$3.06 \times 10^6$

## AIRPLANES -- B727

MODEL	CO	HC	NO <sub>x</sub>	SO <sub>x</sub>	Particulates
EDMS	$1.37 \times 10^8$	$3.69 \times 10^7$	$5.43 \times 10^7$	$5.90 \times 10^6$	$1.95 \times 10^6$
AP-42	$9.26 \times 10^7$	$2.22 \times 10^7$	$4.91 \times 10^7$	$5.40 \times 10^6$	$1.94 \times 10^6$
GSE	$4.02 \times 10^7$	$8.94 \times 10^6$	$2.85 \times 10^6$	-	-
APU	$4.86 \times 10^6$	$1.21 \times 10^6$	$3.69 \times 10^6$	$6.46 \times 10^5$	-
SHUTDOWN	-	$4.23 \times 10^6$	-	-	-
TOTAL	$1.38 \times 10^8$	$3.66 \times 10^7$	$5.56 \times 10^7$	$5.94 \times 10^6$	$1.94 \times 10^6$

TABLE B-4  
VALIDATION RESULTS (CONT.)

AIRPLANES--B737

MODEL	CO	HC	NOx	SOx	Particulates
EDMS	$7.93 \times 10^7$	$2.09 \times 10^7$	$3.66 \times 10^7$	$4.19 \times 10^6$	$1.29 \times 10^6$
AP-42	$6.18 \times 10^7$	$1.49 \times 10^7$	$3.27 \times 10^7$	$3.61 \times 10^6$	$1.28 \times 10^6$
GSE	$1.21 \times 10^7$	$2.69 \times 10^6$	$8.07 \times 10^5$	-	-
APU	$5.40 \times 10^6$	$1.50 \times 10^6$	$3.33 \times 10^6$	$5.88 \times 10^5$	-
SHUTDOWN	-	$2.83 \times 10^6$	-	-	-
TOTAL	$7.92 \times 10^7$	$2.19 \times 10^7$	$3.68 \times 10^7$	$4.20 \times 10^6$	$1.28 \times 10^6$

AIRPLANES--DH-6

MODEL	CO	HC	NOx	SOx	Particulates
EDMS	$1.18 \times 10^7$	$8.60 \times 10^6$	$1.35 \times 10^6$	$2.76 \times 10^5$	-
AP-42	$1.14 \times 10^7$	$8.60 \times 10^6$	$1.35 \times 10^6$	$2.92 \times 10^5$	-

(INTENTIONALLY BLANK)

APPENDIX C

EXAMPLE PROBLEM RESULTS

1. After the example problem is completed the computer will print out two reports; an emissions inventory report and an input file for the PAL dispersion model. The first page of each report is listed below to enable the user to check his results.

1.1 EMISSION REPORT - POWER PLANTS

Detailed emission report:

SITE: WASHINGTON NATIONAL AIRPORT

Note: - All values are in grams.

SOURCE TYPE: BITUMINOUS COAL POWER PLANT

SITE NAME: PUGET POWER #1

ID NUMBER: 388

TEMPORAL: POWER

	CARBON MONOXIDE	HYDROCARBONS	NITROGEN OXIDES	SULPHUR OXIDES	PARTICULATES
JANUARY	8.928E+05	1.637E+05	2.232E+07	1.161E+08	2.321E+08
FEBRUARY	8.136E+05	1.492E+05	2.034E+07	1.058E+08	2.115E+08
MARCH	8.928E+05	1.637E+05	2.232E+07	1.161E+08	2.321E+08
APRIL	8.640E+05	1.584E+05	2.160E+07	1.123E+08	2.246E+08
MAY	8.928E+05	1.637E+05	2.232E+07	1.161E+08	2.321E+08
JUNE	8.640E+05	1.584E+05	2.160E+07	1.123E+08	2.246E+08
JULY	8.928E+05	1.637E+05	2.232E+07	1.610E+08	2.321E+08
AUGUST	8.928E+05	1.637E+05	2.232E+07	1.161E+08	2.321E+08
SEPTEMBER	8.640E+05	1.584E+05	2.160E+07	1.123E+08	2.246E+08
OCTOBER	8.928E+05	1.637E+05	2.232E+07	1.161E+08	2.321E+08
NOVEMBER	8.640E+05	1.584E+05	2.160E+07	1.123E+08	2.246E+08
DECEMBER	8.928E+05	1.637E+05	2.232E+07	1.161E+08	2.321E+08
TOTAL	1.052E+07	1.928E+06	2.630E+08	1.367E+09	2.735E+09



**END**

**FILMED**

**2-86**

**DTIC**