

MICROCOPY RESOLUTION TEST CHART  
NATIONAL BUREAU OF STANDARDS-1963-A

FPO  
8025  
C. Y

2

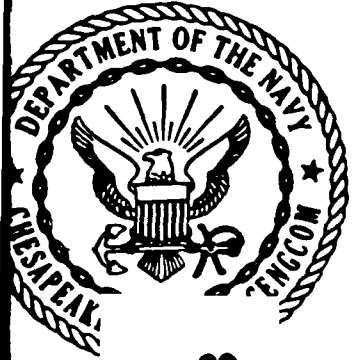

AD-A163 378

AN EVALUATION OF CANDIDATE DESIGNS  
FOR MODIFICATION OF THE PROPULSION SYSTEM  
OF THE BARGE "SEACON"

G&A REPORT NO. 78-026-004

This document has been approved  
for public release and sale; its  
distribution is unlimited.

Prepared By  
GIANNOTTI & ASSOCIATES, INC.

March 28, 1980

Contract No. N62477-78-C-0346

OCEAN ENGINEERING  
AND CONSTRUCTION PROJECT OFFICE  
CHESAPEAKE DIVISION  
NAVAL FACILITIES ENGINEERING COMMAND  
WASHINGTON, D.C. 20374

DTIC  
ELECTE  
JAN 24 1986  
S E D

DTIC FILE COPY

PC 1 0 8 0 2 8

AD-A163378

Unclassified

SECURITY CLASSIFICATION OF THIS PAGE

REPORT DOCUMENTATION PAGE

1a. REPORT SECURITY CLASSIFICATION  
Unclassified

1b. RESTRICTIVE MARKINGS

2a. SECURITY CLASSIFICATION AUTHORITY

3. DISTRIBUTION AVAILABILITY OF REP.  
Approved for public release;  
distribution is unlimited

2b. DECLASSIFICATION/DOWNGRADING SCHEDULE

4. PERFORMING ORGANIZATION REPORT NUMBER  
G&A Report No. 78-026-004

5. MONITORING ORGANIZATION REPORT #  
FPO 8025

6a. NAME OF PERFORM. ORG. 6b. OFFICE SYM  
Giannotti & Associates

7a. NAME OF MONITORING ORGANIZATION  
Ocean Engineering  
& Construction  
Project Office  
CHESNAVFACENGCOM

6c. ADDRESS (City, State, and Zip Code)

7b. ADDRESS (City, State, and Zip )  
BLDG. 212, Washington Navy Yard  
Washington, D.C. 20374-2121

8a. NAME OF FUNDING ORG. 8b. OFFICE SYM  
CHESNAVFACENGCOM

9. PROCUREMENT INSTRUMENT INDENT #  
Contract N62477-78-C-0346

8c. ADDRESS (City, State & Zip)

10. SOURCE OF FUNDING NUMBERS  
PROGRAM PROJECT TASK WORK UNIT  
ELEMENT # # # ACCESS #

11. TITLE (Including Security Classification)  
An evaluation of candidate designs for modification of the propulsion system  
of the barge "Seacon"

12. PERSONAL AUTHOR(S)

13a. TYPE OF REPORT 13b. TIME COVERED 14. DATE OF REP. (YYMMDD) 15. PAGES  
FROM TO 80-03-28 58

16. SUPPLEMENTARY NOTATION

17. COSATI CODES 18. SUBJECT TERMS (Continue on reverse if nec.)  
FIELD GROUP SUB-GROUP SEACON, Barges, Propulsion systems

19. ABSTRACT (Continue on reverse if necessary & identify by block number)  
To improve speed and maneuvering characteristics of the barge SEACON, the  
installation of additional power is under consideration. In this report, five  
candidate designs to accomplish this purpose are described. One design was  
eliminated early-on because of practical considerations. The remaining (Con't)

DISTRIBUTION/AVAILABILITY OF ABSTRACT 21. ABSTRACT SECURITY CLASSIFICATION  
UNCLASS/UNLIMITED X SAME AS RPT. DTIC

22a. NAME OF RESPONSIBLE INDIVIDUAL 22b. TELEPHONE 22c. OFFICE SYMBOL  
Jacqueline B. Riley 202-433-3881

DD FORM 1473, 84MAR SECURITY CLASSIFICATION OF THIS PAGE

BLOCK 19 (Con't)

four designs were evaluated with regard to their impact on speed maneuvering characteristics, conversion costs, and operating cost. Of the four candidates, the design recommended involves the shift of the present forward Detroit Diesel Allison 12V-71 diesel engine and the present Voith-Schneider 14G propulsion unit from the centerline to the starboard side of the Forward Engine Room and the installation of new similar units on the port side. Cost estimates are presented for four of the five designs. The evaluation methodology is described in detail. Contract Guidance drawings for the selected final design are presented. Preliminary Design drawings for the four losing candidates are included. Specifications for the work to be performed and the major items of purchase are provided in an appendix.

TABLE OF CONTENTS

	Page
1. 0 BACKGROUND . . . . .	2
2. 0 DESCRIPTION OF THE CANDIDATE DESIGNS . . . . .	3
2.1 ALTERNATIVE I . . . . .	7
2.2 ALTERNATIVE II. . . . .	9
2.3 ALTERNATIVE III . . . . .	12
2.4 ALTERNATIVE IV. . . . .	14
2.5 ALTERNATIVE V . . . . .	17
2.6 COMMENTS. . . . .	19
3. 0 COST ESTIMATES . . . . .	20
4. 0 EVALUATION . . . . .	20
4.1 EVALUATION PARAMETERS . . . . .	20
4.1.1 SHAFT HORSEPOWER (SHP) . . . . .	20
4.1.2 EFFECTIVE HORSEPOWER (EHP) . . . . .	23
4.1.3 SPEED. . . . .	24
4.1.4 TURNING MOMENT . . . . .	24
4.1.5 BOLLARD PULL . . . . .	26
4.1.6 LATERAL THRUST . . . . .	26
4.1.7 FUEL CONSUMPTION . . . . .	26
4.2 EVALUATION PROCEDURE. . . . .	29
4.3 RECOMMENDATION. . . . .	33
ACKNOWLEDGEMENT. . . . .	34
REFERENCES . . . . .	35

ATTACHMENTS

ATTACHMENT ONE - Preliminary Design Drawings for Alternatives I-IV

ATTACHMENT TWO - Contract Guidance Drawings for Alternatives V



LIST OF TABLES

		Page
Detroit Diesel Allison Marine Engines	Table I	4
Dimensions of Voith-Schneider Propulsors	Table II	6
Summary of Estimated Costs for Propulsion System Modification	Table III	21
Comparison of Alternative Propulsion System Designs	Table IV	22
Normalized Comparisons of Propulsion System Designs	Table V	27
Cost-Performance Comparison of Propulsion System Designs	Table VI	28

#### SUMMARY

To improve speed and maneuvering characteristics of the barge SEACON, the installation of additional power is under consideration. In this report, five candidate designs to accomplish this purpose are described. One design was eliminated early-on because of practical considerations. The remaining four designs were evaluated with regard to their impact on speed and maneuvering characteristics, conversion costs, and operating cost. Of the four candidates, the design recommended involves the shift of the present forward Detroit Diesel Allison 12V-71 diesel engine and the present Voith-Schneider 14G propulsion unit from the centerline to the starboard side of the Forward Engine Room and the installation of new similar units on the port side. Cost estimates are presented for four of the five designs. The evaluation methodology is described in detail. Contract Guidance drawings for the selected final design are presented. Preliminary Design drawings for the four losing candidates are included. Specifications for the work to be performed and the major items of purchase are provided in an appendix.

## 1.0 BACKGROUND

The SEACON is currently propelled by one type 14G Voith-Schneider (V-S) propulsor unit located forward and two similar units located aft. Each unit is driven by a Detroit Diesel Allison (DDA) Model 12V-71 diesel engine. With this system the ship has had difficulty making adequate speed and has had further difficulty bringing her head into the wind in strong breezes, maintaining position, and translating cross-wind. An initial study conducted by the government (Reference 1) examined the problem and considered two possible repowering schemes.

Alt. I: Addition of a 12V-149/V-S 20E system in the space currently occupied by the forward anti-roll tank.

Alt. II: Replacements of the forward DDA 12V-71/V-S 14G units with a DDA 12V-149/V-S 20E system.

Under NAVFAC contract N62477-78-C-0346, Modification 20004, these two alternatives were to be evaluated, recommendations made and preliminary design and contract guidance drawings and specifications prepared. In the course of evaluating the above alternatives it became evident that further alternatives should be considered. Three additional concept designs were developed and evaluated without request for contract modification, one of which was suggested by NAVFAC, and the other two of which were suggested by Giannotti and Associates.

Alt. III: Add a new DDA 12V-149/V-S 20E unit between Frames 11 and 13 in way of the present Generator Room and AC/Pump Room Compartments.

Alt. IV: Remove and relocate the present fresh water tanks in the compartments between Frames 14 and 16 and install two DDA 12V-71/V-S 14G units, one each port and starboard.

Alt. V: Move present forward DDA 12V-71/V-S 14G unit located on the centerline to the starboard side and install a new DDA 12V-71/V-S 14G unit on the portside.

Under subcontract the U. S. Salvage Association prepared cost estimates for Alternatives II - V above.

This report evaluates the candidate designs in terms of cost and feasibility, makes a recommendation, and provides Contract Guidance Drawings and Specifications for principal items of purchase. A description of each of the candidate designs is given in Section 2.0. Section 3.0 presents a summary of costs for the various alternatives. An evaluation and recommendation is made in Section 4.0.

## 2.0 DESCRIPTION OF THE CANDIDATE DESIGNS

In the following section, the features of the five candidate designs will be described. Subsequent sections will describe the rationale leading to the recommendation of Alternative V (installation of an additional 12V-71/14G in the Forward Engine Room) for design selection will be described. For maximum commonality of spare parts and service availability, Detroit Diesel Allison engines are recommended. A comparison of the features of the various engines in this line is shown in Table I. For given weight and space limitations engine output may be increased by operating at higher RPM, up to 2300, vice the standard 1800 RPM for work boat application, and by supercharging and intercooling. These alternatives have been rejected by NAVFAC because of the implication of higher maintenance costs and higher manifold temperatures which lead to unfavorable operating conditions for engine room personnel. Of the engines listed in Table I, the 16V-81 has received very limited acceptance in marine applications and the 16V-149 is too long, leaving the 12V-71, the 16V-71, and 12V-149 as the candidates. Comparing the 16V-71 and the 12V-149 there is considerably more power developed for approximately the same engine length in the 12V-149. Since we are length-critical rather than weight-critical this leads to selection of the 12V-71 and the 12V-149 as the two candidate engines used in the five candidate designs. A comparison of the sizes of these two engines is shown in Figure 1. A tabulation of dimensions on the Voith-Schneider propulsion units is shown in Table II with the dimensional notation defined in the accompanying outline sketch in Figure 2.

TABLE I

DETROIT DIESEL ALLISON MARINE ENGINES

MODEL	TYPE	LENGTH	WEIGHT	BRAKE HORSEPOWER	
				CONTINUOUS	INTERMITTENT
7122	12V-71	79"	4925	340 @ 1800	525 @ 2300
7122	TURBOCHARGED INTER-COOLED 12V-71 T1	79"	5200	-	675 @ 2300
7162	16V-71	124"	7000	455 @ 1800	700 @ 2300
8162	16V-81	115"	7760	600 @ 1800	690 @ 2100
9122	12V-149	129"	13400	675 @ 1800	770 @ 1900
9162	16V-149	148"	17200	900 @ 1800	1025 @ 1900

COMPARISON OF DIESEL SIZE

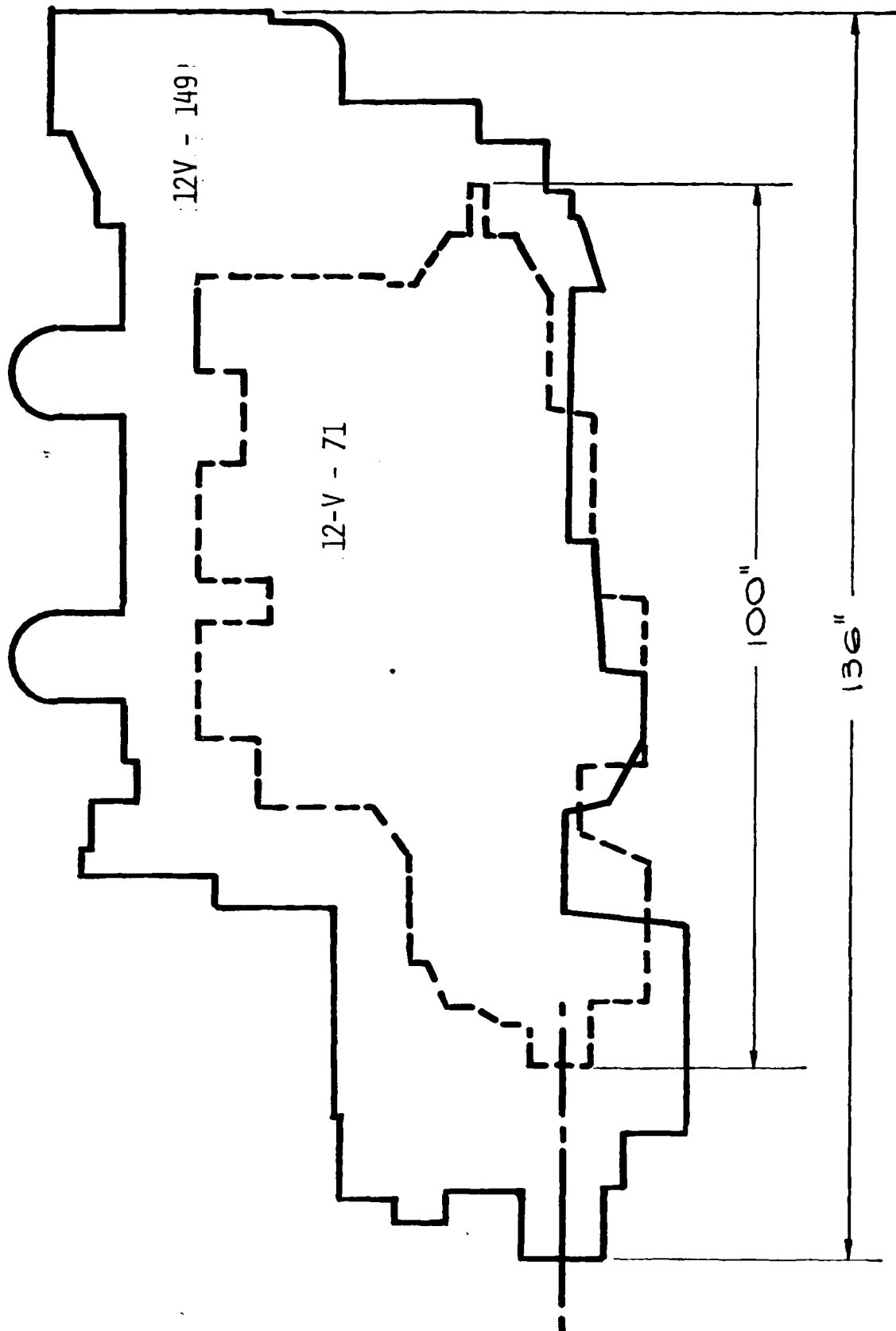

Figure 1

TABLE II  
DIMENSIONS OF VOITH-SCHNEIDER PROPULSORS

As per 1967

Type	D <sub>o</sub> mm	D <sub>Fl</sub> mm	D <sub>R</sub> mm	T <sub>o</sub> mm	Z <sub>Fl</sub>	G mm	W mm	H mm	M mm	60° rotor kg m <sup>2</sup>	Weight ~ kg	Oil filling ~ Ltr.	Voith- gauge lit.	d mm	d <sub>1</sub> mm	l mm	b mm		t <sub>2</sub> mm	c mm	d <sub>2</sub> "	e mm	g mm	n mm	i mm
																	max.	min.							
8 E	1106	800	1010	500	4	749	300	185	520	170	860	80	261	51	44	70	13.982	13.939	3.6 <sup>+0.3</sup>	28	M36x3	86	31	12	10
10 E	1390	1000	1274	650	4	958	395	242	700	440	1665	140	323	56	48	80	13.982	13.939	3.6 <sup>+0.3</sup>	32	M42x3	93	36	12	11
12 E	1650	1200	1532	750	4	1114	482	296	820	1350	2550	240	327	78	68	100	19.978	19.926	4.7 <sup>+0.3</sup>	36	M60x2	123	48	17	14
14 G	1890	1400	1770	900	5	1177	700	336	980	2600	3394	400	.	.	.	.	.	.	.	.	.	.	.	.	.
16 G	2145	1600	2021	1000	4	1320	810	383	1130	5000	5000	600	.	.	.	.	.	.	.	.	.	.	.	.	.
18 G	2405	1800	2263	1150	5	1470	.	419	1200	9000	7900	650	.	.	.	.	.	.	.	.	.	.	.	.	.
20 E	2665	2000	2505	1250	5	1741	795	496	1330	13500	16500	1000	73	133	115.5	175	31.974	31.912	7.1 <sup>+0.3</sup>	65	M100x4	197	80	24	18
24 E	3160	2400	2970	1500	6	2024	920	555	1570	32000	15900	1700	.	~160	.	.	.	.	.	.	.	.	.	.	.
6 G	3360	2600	3170	1650	5	1895	.	575	1575	50000	17500	2400	.	.	.	.	.	.	.	.	.	.	.	.	.
30 G	3880	3000	3680	1850	5	2080	.	640	2100	87000	24000	3000	.	.	.	.	.	.	.	.	.	.	.	.	.
32 G	4170	3200	3950	1850	5	2140	.	690	2200	110000	33000	3500	.	.	.	.	.	.	.	.	.	.	.	.	.

\* according to special drwg.

14 ET	1795	1409	1675	650	6	965	400	225	725	1500	2300	225	391	60	52	80	15.982	15.939	3.9 <sup>+0.7</sup>	32	M42x3	93	36	12	11
18 ET	2290	1800	2150	900	6	1246	550	336	970	5000	5100	600	100	87	76.5	105	21.978	21.926	5.6 <sup>+0.3</sup>	40	M65x2	135	52	19	14
30 ET	3760	3000	3585	1400	6	1992	918	553	1505	58000	18000	2000	.	~100	.	.	.	.	.	.	.	.	.	.	.
16 GT	2090	1600	1970	900	5	1177	700	336	980	3850	3830	550	.	.	.	.	.	.	.	.	.	.	.	.	.

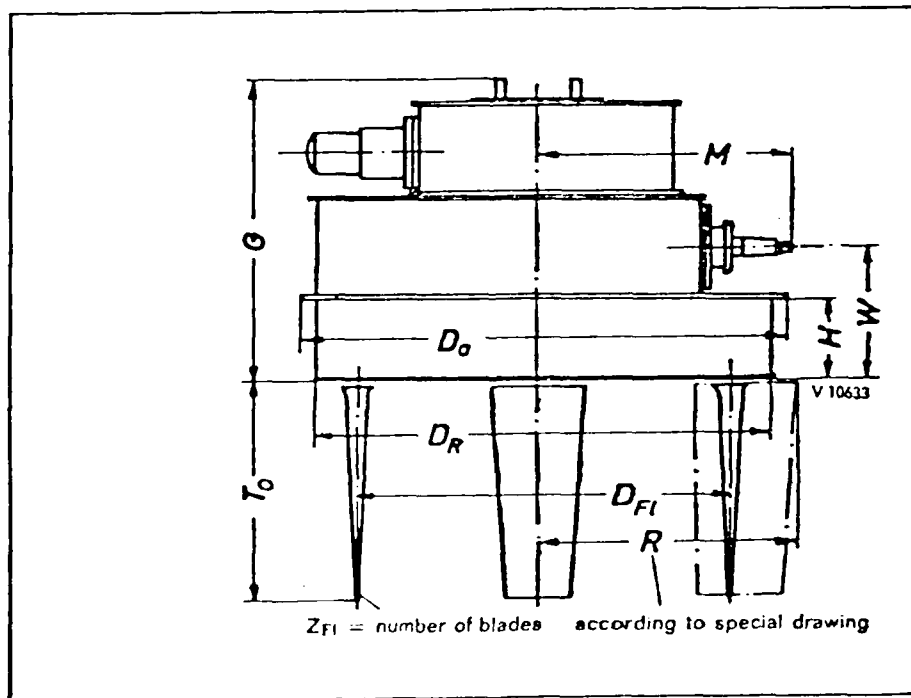

Figure 2 Dimensional sketch of a Voith-Schneider Propulsor

## 2.1 ALTERNATIVE I

In this design the Forward Anti-Roll Tank compartment located forward of Frame 16 would be utilized to install a DDA 12V-71 engine oriented transversely driving a V-S 20E unit. The present compartment extends 8'-0" forward of Frame 16. This dimension would not be sufficient for installation of the engine with allowances for access around each side of the engine. To accommodate the engine and the V-S unit, the boundary bulkhead between the Anti-Roll Tank compartment and the Fresh Water Tank Compartments would have to be moved forward two feet. The arrangement is depicted in Figure 3 with the Preliminary Design drawing included in Attachment One in this report.

The advantages of this alternative are:

1. Access to the proposed location is not difficult. The Main Deck plating in way of the proposed location could be removed easily and access via the Enclosed Work Area in the super-structure is straightforward.
2. The installed power for the barge with this system, 1695 SHP, is greater than all other candidates except Alternative IV which has about the same total installed power.
3. The unit will be influenced by the wake of the forward unit; however, the distance is great enough so that this influence will be small.

The disadvantages of this alternative are:

1. The use of the Forward Anti-Roll Tank would be sacrificed. Although the anti-roll tanks are not effective at present, retuning of these tanks should provide effective roll suppression, a feature which should not be sacrificed.
2. The transverse dimension of the engine requires that the forward bulkhead of the anti-roll tank compartment be moved forward and extended to the bottom. The maximum shift that can be accommodated within the present size constraints of the Fresh Water Tanks in forward adjoining compartment is two feet. To achieve this required that the tanks themselves be shifted about 9" forward. Piping reruns in the Fresh Water Tank Compartments will be required.

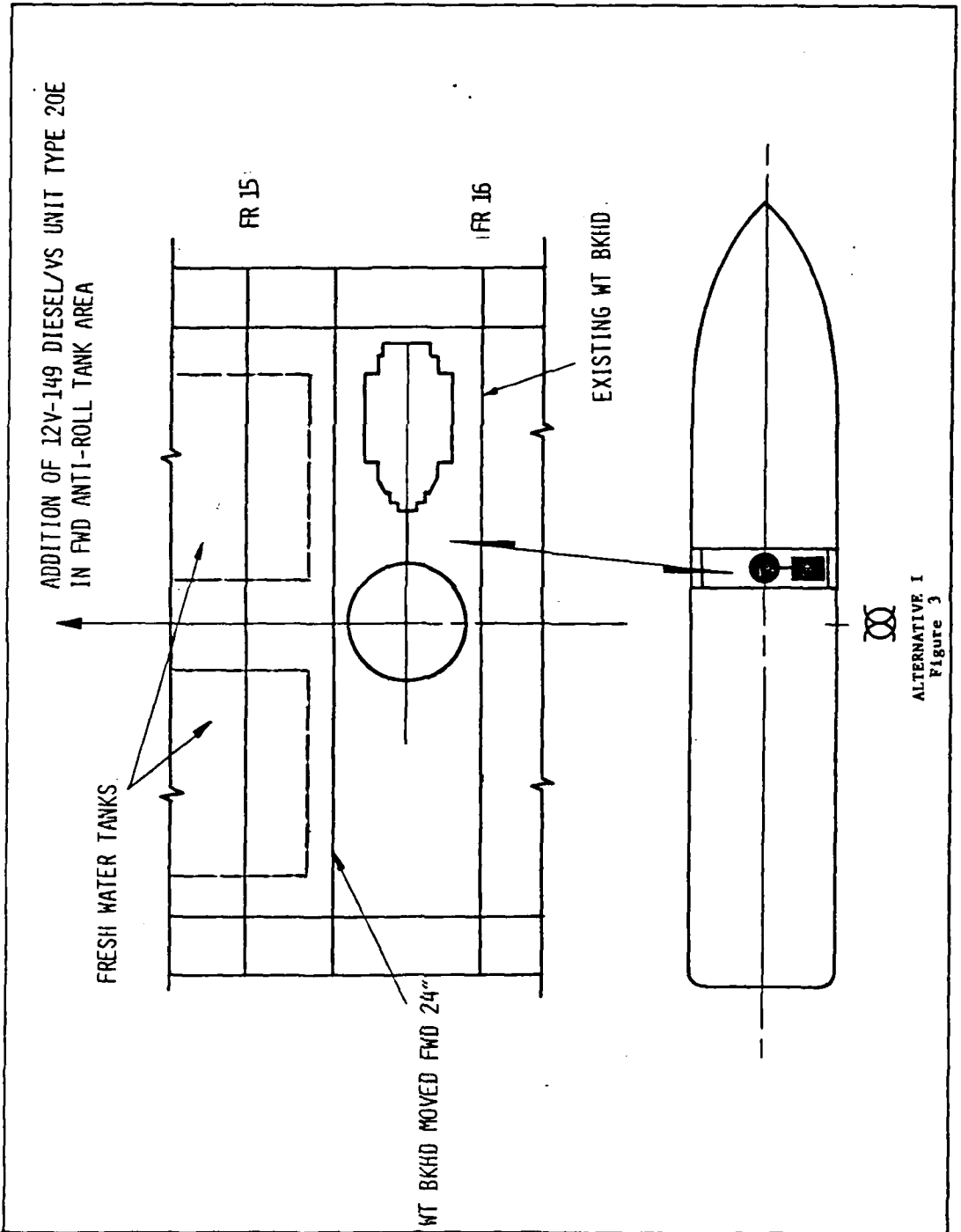

3. Even with the bulkhead move working space between the hot manifolds and the adjacent bulkheads will be only 24"—a tight, in fact, potentially dangerous clearance.
4. The diesel engine would be mounted transversely and subjected to the much larger rolling-induced angular motions in the longitudinal plane of the engine than would be the case of a fore-and-aft orientation. The engine would be capable of operating in this mode, but the situation is not ideal.
5. The off center weight of the engine (13,400 lbs.) will have to be compensated by adjusting the variable ballast, which means that with the tanks dry, the ship will float with a list. An alternative compensation scheme would be to add fixed cement ballast in the bottom on the port side to a depth of about one foot. This would tend to reduce KG and increase the already excessive values of GM which characterize the barges' transverse stability. Other equally unsavory compensation schemes are possible.

Considering the magnitude of the disadvantages outline above, we have recommended against further pursuit of the concept. This view was presented at a NAVFAC staff meeting on November 30, 1979 and approved. Thus, this Alternative will not be carried further in the evaluation process.

## 2.2 ALTERNATIVE II

In this design, the existing DDA 12V-71 engine in the Forward Engine Room and the V-S 14G in the Forward Propulsion Room are removed and replaced with a DDA 12V-149 engine and a V-S 20E propulsor. The increased length of the 12V-149 engine will require that the Frame 11 bulkhead be joggled 12" aft for 5 feet either side of the centerline. A sketch of this scheme is shown in Figure 4.

There are several options for the method of installation. In the first method, the barge would have to be drydocked and blocked up to a height of 8-10 feet. Transverse cuts at Frames 7, 9 and 11, longitudinal cuts about 4'-9" off the centerline port and starboard and a cut through the aft bulkhead of the Propulsion Room would permit the engine and the V-S unit to be lowered through the bottom on their beds with mountings

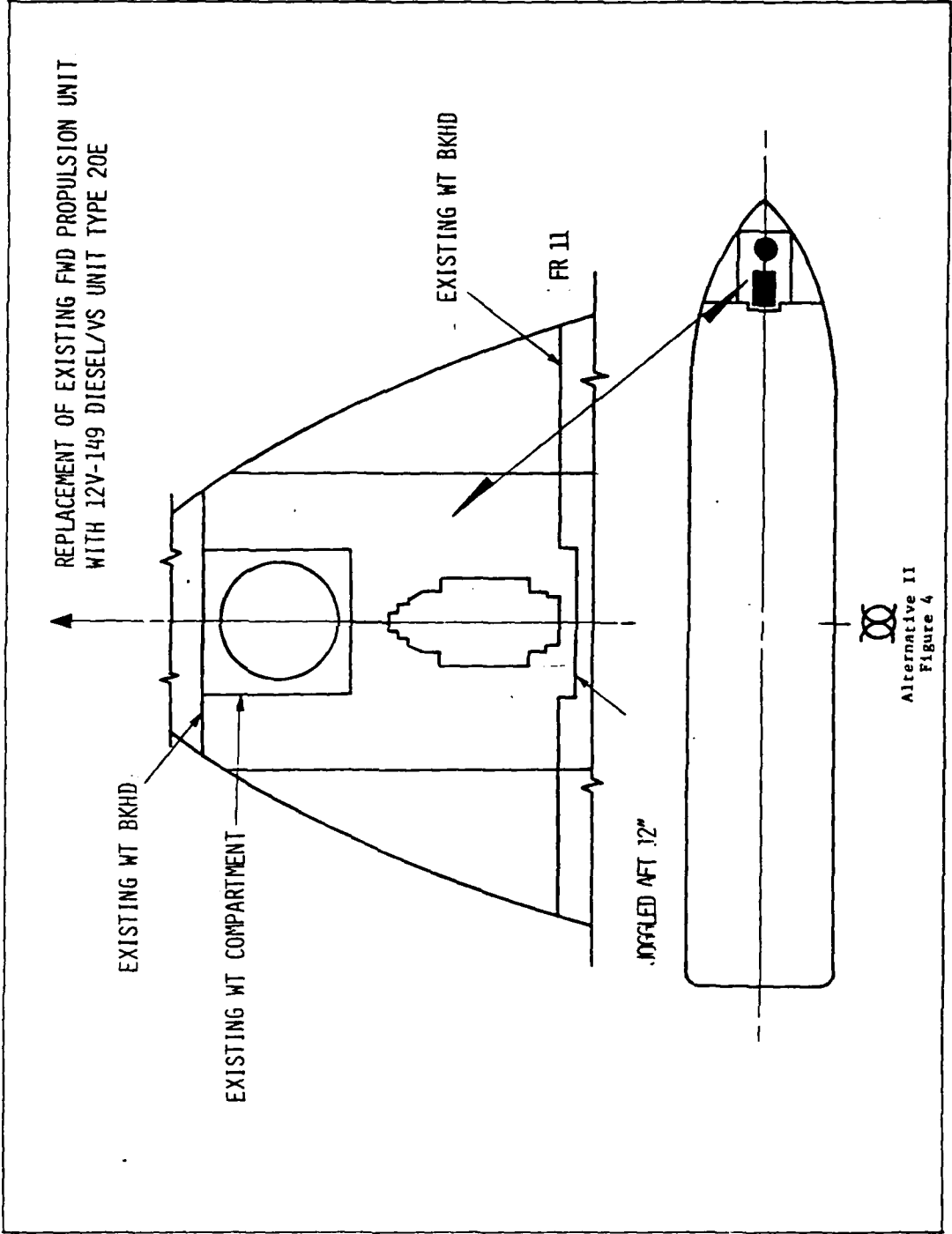

intact. The units would then be removed, new supporting structure erected, new engine and V-S units installed, and the assemblies raised back into position and rewelded to the hull.

The second method would not necessarily require drydocking, although docking will be required for installation of a new sea chest. In this case the barge would be trimmed down by the stern with the forefoot out of the water and an opening cut in the side shell between Frames 7 and 11 from approximately the 5-ft. waterline to the 13 ft. waterline. The interior longitudinal bulkheads bounding the Forward Engine Room and the Forward Propulsion Room would be removed. The engine, the V-S unit, their beds and supporting structure would then be erected, the new engine and V-S unit installed, and finally, the bulkhead and shell plating replaced. The choice of alteration method must, of necessity, be made by the conversion shipyard based on optimum use of their facilities.

The advantages of this candidate design are:

1. The power increase (675 SHP new less 340 SHP existing = 335 SHP) is located as far forward as is possible thus producing the maximum turning lever arm for bow control. Also because of the distance from the aft units, the interference will be minimized.
2. The spaces occupied by the present engine and V-S unit would be utilized for the new units thus minimizing the cascade effect of relocating piping lines, air compressors, etc.

The disadvantages of this arrangement are:

1. Access to the Forward Engine Room is not simple and direct, but must be effected by one of several methods as discussed above, each of which is relatively complicated and expensive.
2. The engine is too long for the present Forward Engine Room and it will be necessary to joggle the Frame 11 bulkhead 12" aft in way of the engine to accommodate the increased length.
3. Although the present 12V-71 is relatively new and has substantial real value, because of property disposal procedures, this value would not be credited to the cost of the modification, thus increasing its apparent cost.

### 2.3 ALTERNATIVE III

In this option, a sketch of which is shown in Figure 5, a new 12V-149 engine and VS-20E unit would be added on the centerline between Frame 11 and 13 in way of the present Generator Room (port), Machine Shop (starboard) and Pump Room (starboard). The present centerline bulkhead would be cut away in its lower portion and flanged to form a centerline girder in its upper portion, similar to the procedure in the original modification of the Forward Engine Room. The Machine Shop would be re-located aft to Frame 22-23 region just forward of the Aft Engine Room. An air compressor Frame 11 (port) would be relocated on the starboard side in the Pump Room. The present inner bottom Ballast Tank No. 2 which extends over the full breadth of the bottom between wing tank bulkheads and from Frame 11 to Frame 14 would, under this alteration, be partitioned by watertight boundaries 5'-0" off the centerline, P & S, and by a transverse W.T. floor at frame 13. This would create the recess needed for the engine and V-S unit beds. The V-S unit would not be enclosed in its own compartment as in the case of the present forward unit, but rather it would be bounded by the new watertight longitudinals 5'-0" off the centerline. A new watertight floor would be added between these longitudinals at Frame 12. All of these boundaries would extend only to the Tank Top level 3'-0" above the Base Line. The supporting structure for the V-S unit would extend past No. 1 and 2 longitudinals to No. 3, P & S, to distribute the lateral thrust load from the V-S unit into the hull structure. The CVK would have to be cut and flanged in the way of the engine installation, but the local loss in section modulus would be more than compensated by the new full 3'-0" deep longitudinals which form the ballast tank boundaries.

A variation of this design would be to reverse the position of the engine and V-S unit by placing the engine forward between Frames 11-12 and the V-S unit aft between Frames 12-13. This arrangement would reduce the interference effect between the present propulsor and the new units. Thus, more net EHP would be produced when thrusting in the longitudinal direction and a slightly more favorable speed improvement would be gained. At the same time there would be a loss in the turning lever arm due to moving the V-S unit further aft and thus a reduction in Turning Moment

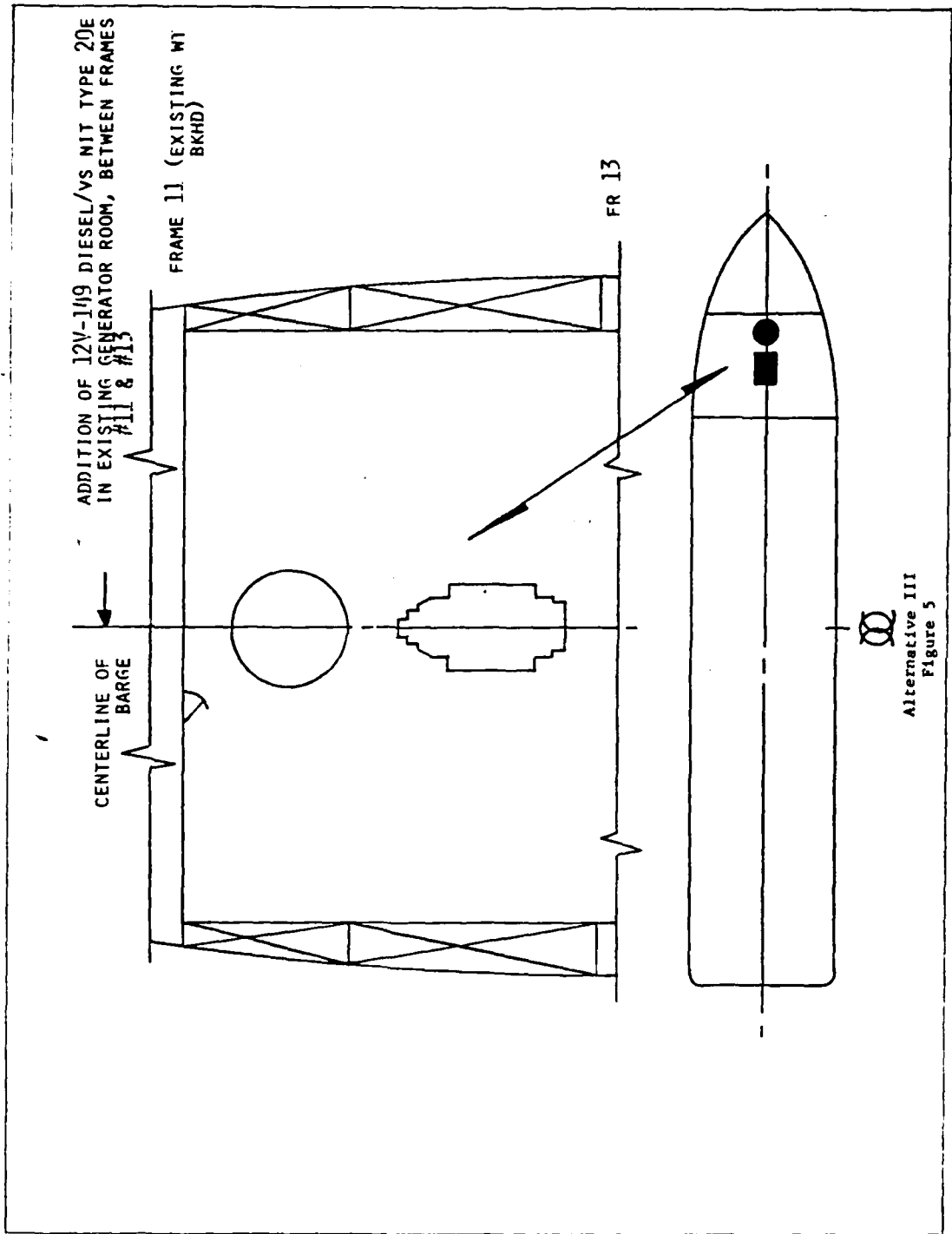

would result. For purposes of concept evaluation, the arrangement with the V-S unit forward has been selected.

Installation of the engine and V-S unit could follow either one of two paths similar to those described in Alternative II--through the bottom or through the side depending on the shipyard's facilities. In this case, installation through the port side would require a cut through F. O. Tank No. 2 and temporary removal of the Vacuum Collection Unit and the Incinerator Unit to provide access. Installation through the starboard side would probably be by cutting through F.O. Tank No. 3. Temporary removal of the A/C units would be necessary. For this Alternative, the most favorable trade-off would probably be in favor of accepting a longer drydocking period and entering through the bottom as described in Alternative II.

The advantages of this Alternative are:

1. The total installed power (1695 SHP) is greater than any of the other four remaining candidates except Alternative IV which is approximately the same.
2. With both the existing V-S unit forward and this new unit thrusting laterally, the Turning Moment will be larger than that produced by any of the other candidates.

The disadvantages of this design are:

1. Installation is complex requiring temporary removals and installations.
2. When thrusting longitudinally, there will be strong interference effects between the present forward unit and the new unit. Because of this, the speed increase will not be as large as Alternative IV which has approximately the same horsepower.

#### 2.4 ALTERNATIVE IV

In this design, shown in Figure 6, the Fresh Water Tanks, P & S presently located between Frame 14 and the Forward Anti-Roll Tank would be removed. In these compartments would be located new 12V-71 engines driving 14G units, one set each port and starboard. Removal of these

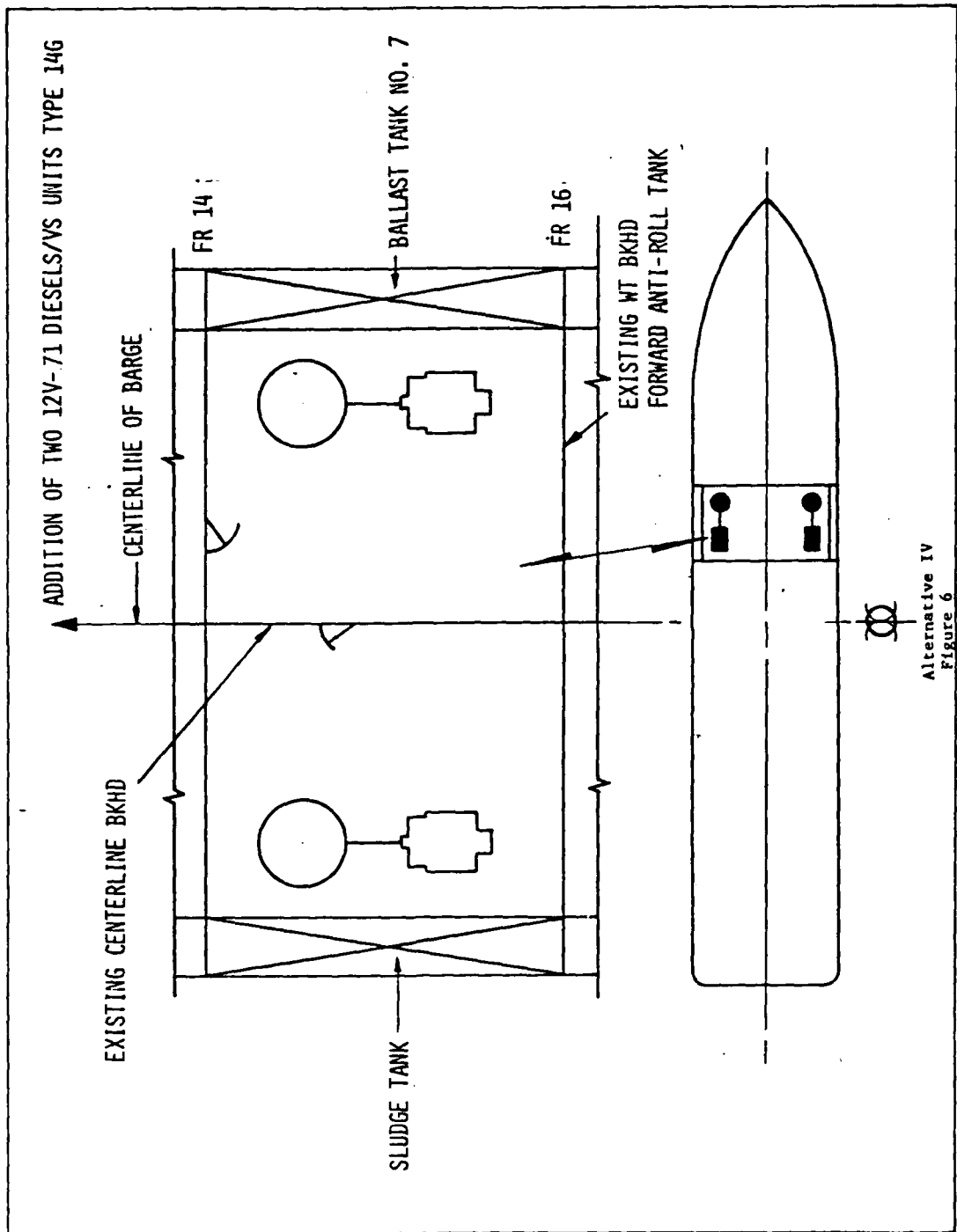

large Fresh Water Tanks would have to be through the port and starboard sides between Frames 14 and 15½. The tanks would be reinstalled in No. 5 Deep Tank just aft the Aft Anti-Roll Tank. Access to this region would be through the Main Deck between Frames 18½ - 20. A large number of piping interruptions and re-runs would be involved in this modification.

The advantages of this system are:

1. The new units could be located well outboard, 15'-0" off the centerline. This separation will enhance normal maneuvering control and minimize interference effects between the present forward unit and the new units and between the new units and the present aft units.
2. Because of the reduced interference effects, the Bollard Pull, the EHP, and the Speed produced by this alteration will be the most favorable of all the candidates.
3. Use of the 12V-71 units means that all engines on the ship, both propulsion and generator, are of the same type, thus simplifying spare parts control. A similar statement applies to the case of the V-S units.

The disadvantages of this design are:

1. The extensive nature of the modification required to effect the removal and reinstallation of the Fresh Water Tanks make this Alternative the most expensive of all the four remaining candidates.
2. Because of the location, the turning lever arm is relatively short and Turning Moment produced by this design is least of all the remaining four candidates.
3. There will be interference effects between the two new V-S units when thrusting laterally. Based on measurements made in Bollard Pull tests, Reference 2, there is an increase in the horsepower absorbed by one unit which just about compensates for the decrease in power absorbed by the other units so that this is apparently not a major consideration.

## 2.5 ALTERNATIVE V

In this case, the present 12V-71 engine and V-S 14G unit located on the centerline would be moved to the starboard side 5'-0" off the centerline and a new 12V-71 and 14G installed on the port side. (See Figure 7). Access to the Forward Engine Room to effect the installation could follow either of the two methods outlined under Alternative II--through the port side or through the bottom. In this case, the port side option would most likely prove to be the most favorable cost-wise. The present enclosure around the forward V-S unit would be eliminated and replaced by a tank top high transverse WT floor at the location of the present aft bulkhead of the Propulsor Compartment, 4'-0" aft Frame 8. Thus, the Forward Engine Room would extend from Frame 7 to Frame 11 and between the longitudinal bulkheads 10'-0" off  $\alpha$ . The WT CVK and the WT floor 4'-0" aft Frame 8 would extend to Tank Top Level 3'-0" above the Base Line. The boundaries of the present Ballast Tank No. 1 P & S would remain at the WT bulkheads 10'-0" off the centerline P & S.

It is understood that the intent of the present WT compartment surrounding the forward propulsor is to facilitate pressurization and unit removal in the event blade replacement at-sea is necessary. The operating history of the SEACON suggests that it is extremely unlikely that such a repair would be attempted, and with an additional unit on line, it becomes even less likely. The reason for abandoning the watertight enclosure concept is to facilitate routine access to the units and to save the expense of reinstalling the bulkhead. In the unlikely event that removal of a V-S unit in the water is required, then the entire Forward Engine Room could be pressurized to prevent the water level from rising through the opening. Local slop-over would be contained by the WT CVK and floor. Dewatering would be accomplished by using the Bilge and Ballast system.

The advantages of this candidate design are:

1. The design takes best advantage of the existing engine and the available space. The total installed power (1360 SHP) is about the same as Alternative II, but in this case, a much smaller engine is purchased.

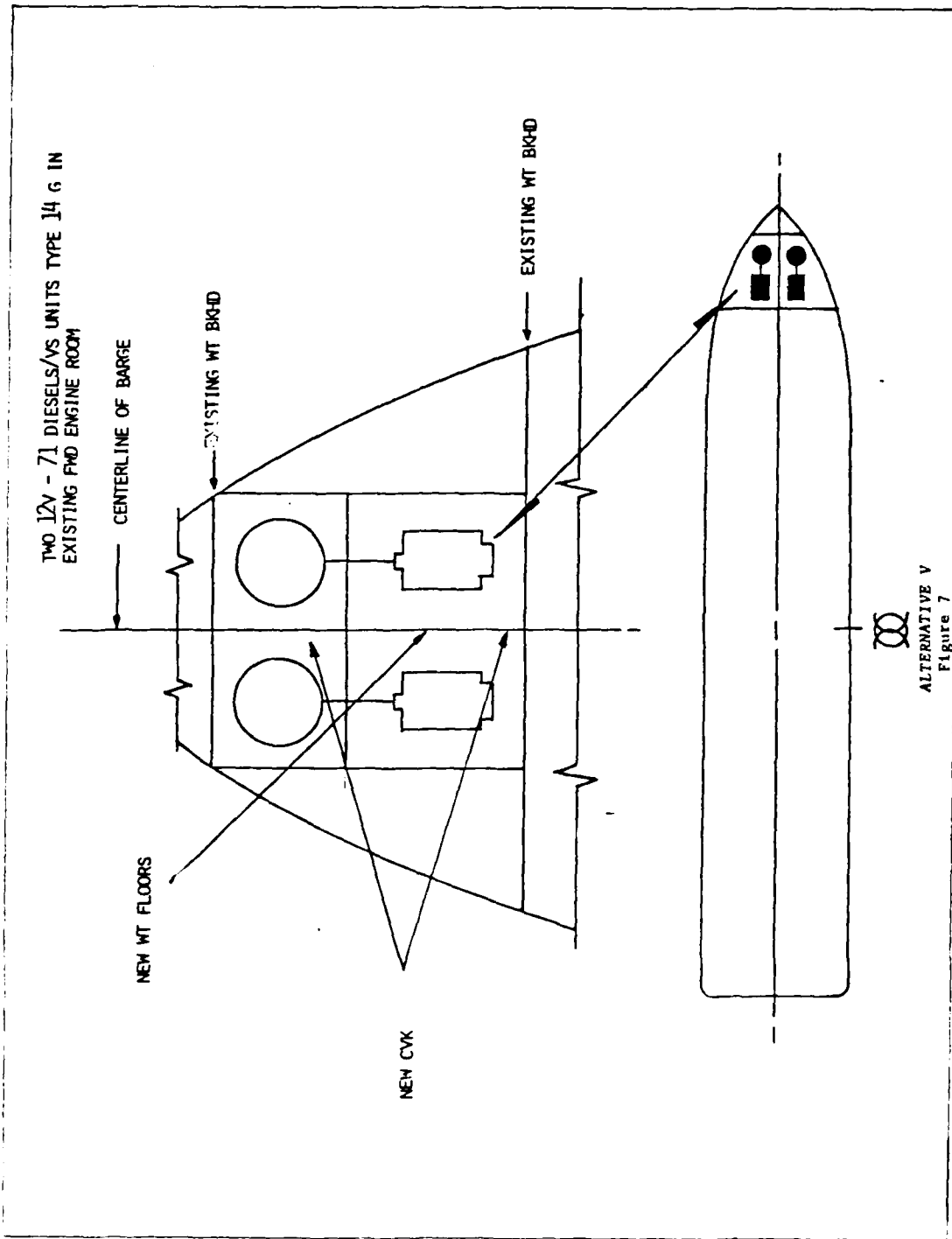

2. The added power is effective at the longest turning lever arm. This together with Alternative II gives the best increase in Turning Moment for the increase in power involved.
3. All engines and V-S units will be of the same type thus simplifying spare parts control.
4. The Fuel Consumption under this option, 77.6 gallons/hr. at full power, is least of all the candidates, although Alternative II at 78.2 gallons/hr. is close. Fuel Consumption affects both operating costs and endurance.

The disadvantages of this design are:

1. There will be interference effects between port and starboard units when thrusting laterally. Again, Reference 2 suggests that the loss on one side is just about offset by an increase on the other side. The interference effects between forward and aft units when thrusting longitudinally, although small, will be somewhat greater with two units forward than with one.

## 2.6 COMMENTS

Before moving on to a presentation of costs several general comments are appropriate.

1. If an increased Turning Moment were not a consideration in selecting the design, then the best alternative would be to install two 12V-71/14G systems in Deep Tank No. 5 between Frames 18½ and 20. The resulting arrangement would be similar in appearance to Alternative IV with the engines located 15'-0" off the centerline. Access to the compartments through the main deck is simple and direct. Costs, even with two engines involved, could be expected to be less than any of the others considered.

Since the effect of this design would be to produce primarily an increase in Speed with not much improvement in Turning Moment it has not been developed in this study. However, should NAVFAC priorities change in this regard, then this alternative should be re-examined.

2. In any of the cases considered additional sea chest capacity will be required. The proposed solution is to add a new sea chest at the same corresponding location on the port side.

### 3.0 COST ESTIMATES

Using information provided by Giannotti & Associates, Inc, the United States Salvage Associates Inc. prepared cost estimates for Alternatives II through V. These estimates were prepared using typical 1979 cost data, data which, incidentally, is proprietary to U. S. Salvage. While these estimates with appropriate escalation figures may be used for budgetary purposes with reasonable confidence, actual bid responses from shipyards may be expected to come in both lower and higher than the estimated figures.

A summary of the estimated costs appears in Table III. The table also shows the ratios  $C/C_{\max}$  and  $C_{\min}/C$  where  $C_{\max}$  and  $C_{\min}$  are maximum and minimum costs respectively.

Table III shows that the least expensive system is Alternative V followed in order by Alternative II and Alternative III. As expected, the most expensive system, because of the expensive tank re-locations, is Alternative IV.

### 4.0 EVALUATION

#### 4.1 EVALUATION PARAMETERS

In the subsections that follow the various performance parameters that are important in evaluating the merit of candidate designs will be discussed and their estimating basis outlined. A summary of the values for each parameter for the present configuration and for Alternatives II through V is shown in Table IV. The table also shows the percentage increase each parameter will experience for the various candidate schemes.

##### 4.1.1 Shaft Horsepower (SHP)

Usual naval architectural practice is to define SHP as the output power of a turbine system as measured aft of the

TABLE III

SUMMARY OF ESTIMATED COSTS  
FOR PROPULSION SYSTEM MODIFICATION

	Cost, C	$\frac{C}{C_{max}}$	$\frac{C_{min.}}{C}$
Alternative II			
Replace exist. 12V-71/14G fwd. with 12V-149/20E	\$734,095	.617	.891
Alternative III			
Add a 12V-149/20E bet. frs. 11-13	\$888,695	.747	.736
Alternative IV			
Add two 12V-71/14G units between frs. 14-16	\$1,190,412	1.00	.549
Alternative V			
Add one 12V-71/14G fwd.	\$653,806	.549	1.00

TABLE IV  
COMPARISON OF ALTERNATIVE PROPULSION SYSTEM DESIGNS

	SHP		Fuel Consumpt. gals/hr		EHP		Speed kts.		Bollard Pull lbs		Lateral Thrust lbs		Turning Moment ft-tons	
	New	% Incr.	New	% Incr.	New	% Incr.	New	% Incr.	New	% Incr.	New	% Incr.	New	% Incr.
Present Configuration	1020		58.2		275		7.9		15,250		10,000		501	
Alt. II	1355	33	78.2	34	366	33	8.8	11	21,750	43	13,230	32	654	31
Alt. III	1695	66	97.6	68	384	40	8.9	13	23,100	51	16,480	65	750	50
Alt. IV	1700	67	97.0	67	445	62	9.3	18	27,040	77	16,750	68	626	25
Alt. V	1360	33	77.6	33	365	33	8.8	11	20,510	34	13,500	35	667	33

gear and bearing and as close as possible to the stern tube. Diesel engine power output is usually identified as Brake Horsepower (BHP). However, Detroit Diesel Allison defines the output of their engines (with water pump installed) at the output stub of the engine and before gear and bearings as SHP. We will follow their lead.

The SHP's shown in Table IV represent the total installed SHP for the system based on manufacturer Rated SHP at 1800 RPM. Alternatives III and IV have the largest installed SHP with 1695 and 1700 respectively. For Alternatives II and V the installed SHP is less with values of 1355 and 1360.

#### 4.1.2. Effective Horsepower (EHP)

Effective Horsepower is the power actually delivered to the water by the propulsion system and effective in propelling the ship (barge). In this case the SHP output of the engines is subjected to losses in the reduction gearing, the V-S linkage, and in the hydrodynamic efficiency of the V-S blading. In addition, the overall EHP is affected by hull-propulsor interactions, (Thrust Deduction, Wake Fraction) an important factor in this case, and by the Relative Rotative Efficiency, an artificial correction factor that accounts for the difference in hydrodynamic performance of a propulsor as tested in open water and as actually installed on a ship. The EHP inferred by working back through the propulsion system may be matched to the EHP as determined by measurements of the ship's hull resistance in a model test. References 2, 3, and 4 are earlier SEACON reports which provide background information on EHP, hull-propulsor interactions, propulsor interactions and bollard pull.

In arriving at the EHP figures shown in Table IV allowance has been made for interference effects between propulsors. The interference factor has been estimated using the propulsor curves presented in References 2 and 4. As the inflow velocity

to the propulsor increases, the thrust developed decreases; however, the efficiency increases up to a maximum value, then decreases. The increased efficiency means that less torque is demanded from the engine, or alternatively, that the pitch of the blades may be increased to absorb the available torque and increase the thrust. Consider, for example, Alternatives II and IV shown in Table IV. The installed power is nearly the same, however in Alternative III the new V-S unit is mounted 25 feet astern of and in the wake of the existing unit, while Alternative IV with its units mounted well outboard is relatively free of the effect, although the wake from these units will have some effect on the stern units. The net of all these effects is estimated to make a significant difference in the EHP, 384 EHP for Alternative II versus 445 for Alternative IV.

#### 4.1.3 Speed

A curve of EHP versus Speed for the 8'x10' draft condition was presented in Reference 4 based on interpolated model test data and is reproduced here as Figure 8. The applicable curve is labeled "Best Estimate, Trial Condition". The speeds shown in Table IV have been arrived at by entering this curve with the EHP estimated as outlined above. Table IV shows that the best speed increase is achieved by Alternative IV with a predicted new speed of 9.3 knots. The remaining Alternatives show smaller speed increases of about a knot.

#### 4.1.4 Turning Moment

The Turning Moment is defined to be the total moment of the thrust of the forward and aft propulsors when thrusting laterally in opposite directions. The lateral thrusting capability has been inferred from the results of the bollard pull experiments reported in Reference 4. In those experiments, it was reported that the present system delivers only 10,000 lbs. of thrust

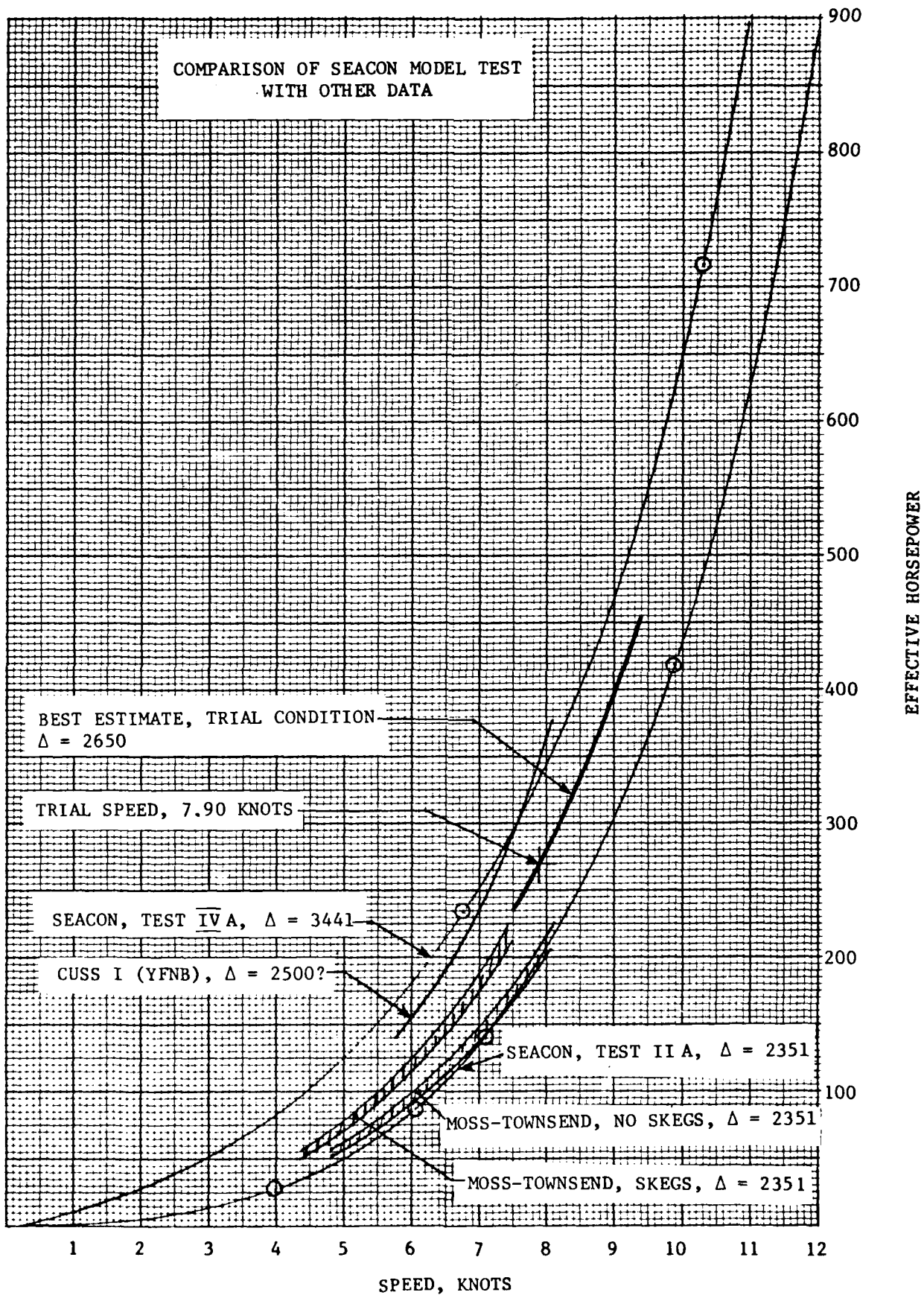

Figure 8.

when thrusting laterally, although when thrusting longitudinally the system produces 15,250 lbs. of thrust. This effect is reflected in the Table IV estimates. Alternative III with a total of 1015 SHP in the forward region shows a clear advantage in Turning Moment.

#### 4.1.5 Bollard Pull

Again, the results of the bollard pull experiments have been used as a basis for making the Bollard Pull estimates shown in Table IV. Interference effects have been considered. Interference effects will be somewhat more prominent in the Bollard Pull estimates than in the EHP estimates because of the moderating influence of forward speed. A comparison of the results for Alternatives III and IV again indicates that interference effects make an important difference. The largest values of Bollard Pull may be expected from Alternative IV.

#### 4.1.6 Lateral Thrust

Lateral thrust is the total lateral thrust developed when all propulsors are thrusting laterally in the same direction. The same thrust values are used here as in the case of Turning Moment; however, in this case the effect of turning lever arm is not considered. Again, compare Alternatives III and IV in Table IV. Both designs produce similar values of Lateral Thrust, but Alternative III because its more forward position and large lever arm produces a considerably greater Turning Moment.

#### 4.1.7 Fuel Consumption

Fuel consumption will affect the barge in two ways. As the Fuel Consumption rate is increased, first, the operating costs are increased, and, second, the endurance of the barge

TABLE V

NORMALIZED COMPARISONS OF PROPULSION SYSTEM DESIGNS

	← PERFORMANCE →						← COST →				TOTAL SCORES			
	SPEED		TURN. MOM'T.		BOLL. PULL		LAT. THRUST		FUEL CONS.		COST		(A)	(B)
	Nrm.	Weight (A) (B)	Nrm.	Weight (A) (B)	Nrm.	Weight (A) (B)	Nrm.	Weight (A) (B)	Nrm.	Weight (A) (B)	$\frac{C}{\min \frac{A}{B}}$	Weight (A) (B)		
Alt. II	.946	.189 .237	.872	.174 .218	.804	.080 .080	.790	.040 .079	.992	.050 .050	.891	.356 .223	.889	.887
Alt. III	.956	.191 .239	1.00	.200 .250	.854	.085 .085	.984	.049 .098	.795	.040 .040	736	.294 .184	.859	.896
Alt. IV	1.00	.200 .250	.834	.167 .209	1.00	.100 .100	1.00	.050 .100	.80	.040 .040	549	.220 .137	.827	.836
Alt. V	.946	.189 .237	.889	.178 .222	.758	.076 .076	.806	.040 .081	1.00	.050 .050	1.00	.400 .250	.933	.916

	Weighting Factors	
	(A)	(B)
Speed	20%	25%
Turning Moment	20	25
Bollard Pull	10	10
Lateral Thrust	5	10
Fuel Consumption	5	5
Cost	40	25
	100%	100%

TABLE VI  
 COST-PERFORMANCE COMPARISON OF PROPULSION SYSTEM DESIGNS

	PERFORMANCE										TOTAL SCORE	COST SCORE $\frac{C}{C_{max}}$
	SPEED Nrm.	SPEED Weight ( C )	TURN. MOM'T Nrm.	TURN. MOM'T Weight	BOLL. PULL Nrm.	BOLL. PULL Weight	LAT. THRUST Nrm.	LAT. THRUST Weight	FUEL CONS. Nrm.	FUEL CONS. Weight		
Alt. II	.946	.284	.872	.262	.804	.121	.790	.119	.992	.099	.885	.617
Alt. III	.956	.287	1.00	.300	.854	.128	.984	.148	.795	.080	.943	.747
Alt. IV	1.00	.300	.834	.250	1.00	.150	1.00	.150	.80	.080	.930	1.00
Alt. V	.946	.284	.889	.267	.758	.114	.806	.121	1.00	.10	.886	.549

Weighting Factor  
 C  
 Speed 30%  
 Turning Moment 30  
 Bollard Pull 15  
 Lateral Thrust 15  
 Fuel Consumption 10  
 100%

is decreased. The Fuel Consumption figures cited in Table IV are the total of the manufacturer's figures at rated power and 1800 RPM for all the engines in the propulsion system.

#### 4.2 EVALUATION PROCEDURE

The experienced designer in considering the costs of the various alternatives tabulated in Table III and the performance characteristics given in Table IV would note the following facts.

1. The best increases in Speed, Bollard Pull, and Lateral Thrust are made with Alternative IV. At the same time, this is nearly twice as expensive as the least expensive Alternative, Alternative V.
2. The best increase in Turning Moment is made with Alternative III, but this costs about 36% more than Alternative V.
3. Alternative II has roughly the same performance characteristics as Alternative V; however, Alternative V is about 12% more expensive.
4. Although Alternative V is most favorable in only one characteristic, Fuel Consumption, the performance benefits relative to the cost are favorable.

On this basis the experienced designer would probably decide on Alternative V as the best compromise between cost and performance benefits. However, with the advent of the modern discipline of Systems Analysis such intuitive judgements no longer have the same degree of credibility that they once had. Accordingly we will examine the problem from two other more analytical points of view.

In the first approach we will score the various alternatives by weighing each of the performance factors and the cost in proportion to its importance in the overall picture. The scoring is done by normalizing each of the factors and then applying a Weighting Factor. In the case of Cost and Fuel Consumption, minimum values are most desirable and deserve the highest score, thus the minimum value is used as the normalization base. To investigate the sensitivity of the choice of Weighting Factors two sets of Weighting Factors are used with weightings as shown :

	<u>Weighting Factor</u>	
	(A)	(B)
Speed	20%	25%
Turning Moment	20	25
Bollard Pull	10	10
Lateral Thrust	5	10
Fuel Consumption	5	5
Cost	<u>40</u>	<u>25</u>
	100%	100%

The resulting scores are shown in Table V. The columns labeled "Nrm" are the normalized performance ratings computed from the performance ratings of Table IV as described above. The columns labeled (A) and (B) are the individual performance scores obtained by multiplying the normalized performance rating by the above Weighting Factors in decimal form. The total of the individual scores lead to ranking the Alternatives in the following order according to which set of Weighting Factors is used.

<u>Ranking</u>	(A)	(B)
1.	Alt. V	Alt. V
2.	Alt. II	Alt. III
3.	Alt. III	Alt. II
4.	Alt. IV	Alt. IV

For both weighting systems Alternative V has the highest score and Alternative IV has the poorest score. Alternative II leads Alternative III in weighting (A) which has the heavier emphasis on Cost. The situation is reversed for weighting (B).

Another perspective in evaluating the merits of the various Alternatives is obtained by viewing Performance as an independent variable, (X), and Cost as a dependent variable, (Y), then displaying the normalized results on a plot from which optimum solutions may be inferred. In this approach Cost is normalized on the basis

of the maximum value, not the minimum value as in the previous treatment. Since Cost is now treated as a dependent variable, it is excluded from weighting of the Performance Factors. Only one weighting, (C), has been chosen for this illustration.

	<u>Weighting Factor</u>
	(C)
Speed	30%
Turning Moment	30
Bollard Pull	15
Lateral Thrust	15
Fuel Consumption	10
	<hr style="width: 10%; margin: 0 auto;"/>
	100%

Performance and Cost are now scored separately with the results shown in Table VI. The best Performance score is now obtained by Alternative III followed closely by Alternative IV. Alternatives II and V are virtually tied for third place.

A graphical display of these results is shown in Figure 9. In typical design analyses, regardless of the particular engineering field of application, the plot of the various solutions tends to curve up to the right in this type of presentation. Low cost and low performance (or low effectiveness) solutions appear in the lower left and high performance-high cost solutions appear in the upper right. In our case the solutions are arrayed in almost a vertical line. The plot displays rather vividly that, in perspective, the performance differences between Alternatives are modest while the cost differences are dramatic.

One may argue that the ultimate solutions would be one with a Performance rating of 1.0 and a Cost rating of 0.0, an impossible situation, of course. However the solution which most nearly approaches this point could be viewed as the optimum trade-off between Cost and Performance. This is found simply by choosing the solution with the shortest distance to the point (1.0, 0.0). This position vector is shown in Figure 9. Again Alternative V appears to be the closest to the optimum followed by Alternatives II, III, and IV.

COST-PERFORMANCE COMPARISON  
OF  
PROPULSION SYSTEM DESIGNS

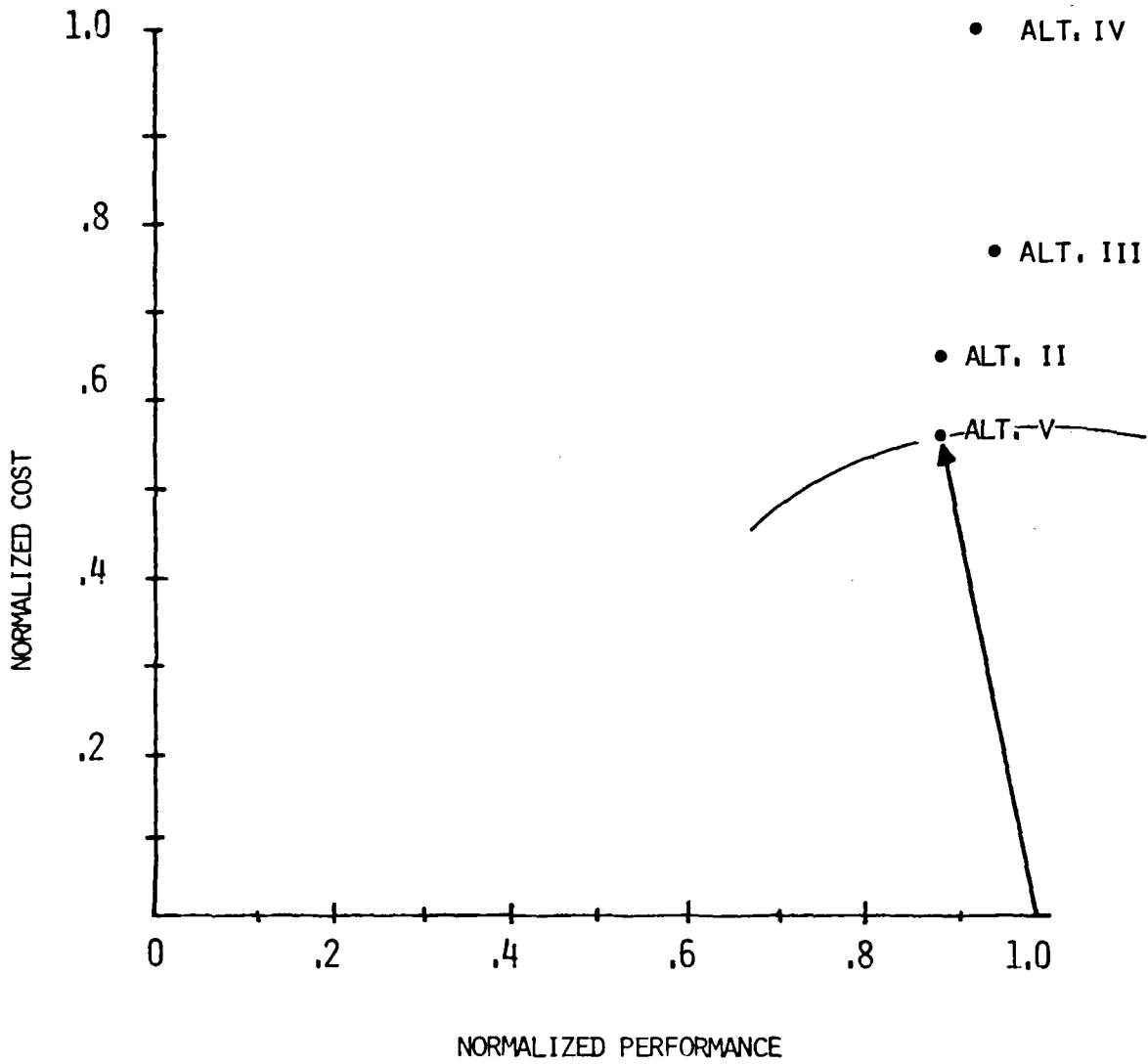

Figure 9

Both the "systems" approaches to the design selection problem have confirmed the intuitive choice of Alternative V as the best compromise between Cost and Performance.

#### 4.3 RECOMMENDATION

1. Alternative V is recommended for selection as the most favorable combination of Cost and Performance, where Performance includes consideration of Speed, Turning Moment, Bollard Pull, Lateral Thrust, and Fuel Consumption. The recommended design involves shifting the present DDA 12V-71 engine in the Forward Engine Room and the accompanying V-S 14G propulsor unit to the starboard side 5'-0" off the centerline. A new DDA 12V-71/V-S 14G system would be installed a similar distance off the centerline on the port side. The total cost of the addition will be approximately \$654,000 in 1979 dollars. A detailed statement of the work required for this modification to the propulsion system is contained in Appendix B. Contract Guidance drawings are presented in Attachment Two in this report. Following the guidance contained in the Statement of Work maneuverability in the presence of winds and seaway has been an important consideration in making this selection. In the event that the importance of maneuverability were to be de-emphasized and speed were to become the dominant consideration, then the recommendation would change. In such case the most likely recommendation would be the installation of two new DDA 12V-71/V-S 14G sets on the port and starboard sides of Deep Tank No. 5. Such an alternative has not been developed or priced in this study.

ACKNOWLEDGEMENT

The helpful assistance of Mr. A.W. McNairy in the execution of this study is acknowledged.

#### REFERENCES

1. NAVFAC Memorandum FPO-1 ED12 dated 24 August 79 from FPO-1 ED12 (A.W. McNairy) to FPO-1ED, Subj: SEACON Performance with Additional Voith-Schneider Propulsion Unit Mounted in Forward Anti-Roll Tank Compartment.
2. "Report of Bollard Pull Tests for the Barge SEACON, Giannotti & Associates, Inc. Report No. 78-026-003, March 6, 1980 for Naval Facilities Engineering Command, Chesapeake Division (FPO-1), Contract No. N62477-78-C-0346.
3. "Directional Stability Model Tests of the Barge SEACON", Giannotti & Associates, Inc. Report No. 78-026-001, January 31, 1979 for Naval Facilities Engineering Command, Chesapeake Division (FPO-1), Contract No. N62477-78-C-0346.
4. "Inspection of the Propulsion System of the Barge SEACON", Giannotti & Associates Report No. 78-026-002, October 18, 1979 for Naval Facilities Engineering Command, Chesapeake Division (FPO-1), Contract No. N62477-78-C-0346.

APPENDIX A

REPORT OF THE UNITED STATES SALVAGE ASS'N, INC.

# UNITED STATES SALVAGE ASSOCIATION, INC.

14 WALL STREET

NEW YORK, N. Y. 10005



EXECUTIVE OFFICE  
212 233 7400

CABLE ADDRESS UNISALVAGE N Y  
TELEX 425988 TWX 710 581 6701

February 14, 1980

Giannotti & Associates Inc.  
703 Giddings Avenue - Suite U3  
Annapolis, Maryland 21401

Attention: Mr. John D. Smaltz  
Senior Designer

Subject: Preliminary Estimates for Repowering  
of the U.S. Navy's Ocean Construction  
Platform "SEACON"  
Case No. 1-1377

Reference: Your letter of Instructions and  
Authorization to Proceed and Submit  
to you the Preliminary Estimates for  
Subject Vessel.

Gentlemen:

We are forwarding herewith the following:

- A. Report and Estimates U.S. Salvage Association Inc., Case No. 1-1377
- B. J. J. Henry Co., Inc., Reference Drawings
- C. Black & White Photographs
- D. Our Invoice for services rendered

We trust that the information provided will enable you to proceed with the repowering project of the vessel "SEACON".

Very truly yours,

Norbert H. Laudorn  
Chief, Estimating Division

NHL:rs

Enclosures

# UNITED STATES SALVAGE ASSOCIATION, INC.

14 WALL STREET



NEW YORK, N. Y., 10005

CASE NO. 1-1377  
Preliminary Estimate  
for Repowering

New York, New York  
February 11, 1980

BARGE "SEACON"

## CONDITIONS

The employment of this Association and all services rendered in connection therewith are made, offered and rendered without recourse and on the following conditions and this and all other reports, including any oral reports and certificates, are made and issued without recourse and subject to said conditions:

1. While the officers and the Board of Directors of United States Salvage Association, Inc. have used their best endeavors to select competent surveyors, employees, representatives and agents and to insure that the functions of the Association are properly executed, neither the Association nor its officers, directors, surveyors, employees, representatives or agents are under any circumstances whatever to be held responsible for any error of judgment, default or negligence of the Association's surveyors, employees, representatives or agents nor shall the Association or its officers or directors under any circumstances whatever be held responsible for any inaccuracy, omission, misrepresentation or misstatement in any report or certificate.
2. That the information contained in this and all other reports and certificates is only that coming to the attention of or under the observation of such surveyors, employees, representatives and agents and deemed pertinent for the purpose for which the Association was employed as stated herein; that this report or certificate is not a Certificate of Seaworthiness; that under no circumstances shall this report or certificate be used in connection with the issuance, purchase, sale or pledge of any security or securities, or in connection with the purchase, sale, mortgage, pledge, freighting, letting, hiring or charter of any vessel, cargo or other property, and if so used shall be null, void and of no effect and shall not be binding on anyone.
3. Reports subject to these conditions are the only reports authorized by the Association.
4. The terms of these conditions can be varied only by specific resolution of the Board of Directors of the Association and the acceptance or use of this report or of the employment or services of this Association or of its surveyors, employees, representatives or agents or the use of any other report or certificate shall be construed to be an acceptance of these conditions.
5. This report and all services in connection with this employment are for the account of the person requesting the same, but with the understanding that they are to be used only for the purpose for which the Association was employed as stated herein.

Giannotti & Associates, Inc.  
703 Giddings Ave. - Suite U3  
Annapolis, Maryland 21401

Attention: Mr. Paul R. Van Mater, Jr., PH.D.  
Vice President

Gentlemen:

Under reference to your instructions to this Association to assist your office in preparing preliminary estimates in connection with the repowering study being prepared by your goodselves for the United States Navy in connection with the subject vessel, we are pleased to offer you our views and cost estimates as follows:

The unit under discussion is an all steel welded Ocean Construction Platform (Barge) of approximate dimensions 260' x 48' x 15' which is maneuvered by three "Voith-Schneider" propellers.

This office was instructed to perform services as indicated in your letter of instructions to the undersigned dated January 9, 1980, over the signature of your Senior Designer, Mr. John D. Smaltz.

Case No. 1-1377

During subsequent conference attended at our office on January 15, 1980, attending your Messrs. Paul R. Van Mater, Jr., Vice President, John D. Smaltz, Senior Designer and the undersigned, the following documents which were mailed to this office with the letter of instruction referred to above were discussed, whereby you made your wishes known in more detail and the general approach to this project was agreed upon.

The following outline of proposals plus drawings was made available:

PROPOSAL NO. 1

INSTALLATION OF TWO 12V-71 DIESELS & VS-14G UNITS  
IN PRESENT FWD ENGINE ROOM

PROPOSAL NO. 2

INSTALLATION OF 12V-149 DIESEL & VS-20E UNIT  
IN FWD ENGINE ROOM

PROPOSAL NO. 3

INSTALLATION OF 12V-149 DIESEL & VS-20E UNIT  
ON CENTERLINE BETWEEN FRAMES 11 & 13

PROPOSAL NO. 4

INSTALLATION OF TWO 12V-71 DIESELS & VS-14G UNITS  
IN AREA NOW OCCUPIED BY FRESH-WATER TANKS

In addition the following drawings and photographs were made available for reference and returned herewith:

- |    |                       |          |             |        |
|----|-----------------------|----------|-------------|--------|
| 1. | J. J. Henry Co., Inc. | DWG. NO. | 1736-100-2  | REV. A |
| 2. | J. J. Henry Co., Inc. | DWG. NO. | 1736-200-1  | REV. A |
| 3. | J. J. Henry Co., Inc. | DWG. NO. | 1736-100-5  | REV. A |
| 4. | J. J. Henry Co., Inc. | DWG. NO. | 1736-100-12 | REV. A |
| 5. | J. J. Henry Co., Inc. | DWG. NO. | 1736-200-2  | REV. B |
| 6. | J. J. Henry Co., Inc. | DWG. NO. | 1736-100-6  | REV. A |

Case No. 1-1377

7. Eighteen black and white photographs (3 1/2 x 5 inches).  
Machinery space details.
8. Leaflet of "Voith-Schneider" propeller dimensions.

PROPOSAL NO. 1

INSTALLATION OF TWO (2) 12V-71N DIESELS AND TWO (2) VS-14G UNITS

IN PRESENT ENGINE ROOM

The following job planning is taken into consideration:

1. Cover machinery and protect same against damage.
2. Support main deck from tank top Fr. 7-11 with stanchions, etc.
3. Cut openings in longitudinal bulkhead - Photo Lab - Port side between Fr. 10 and 11. Material later to be reinstalled.
4. Move air compressors and receivers into Photo Lab.
5. Reinstall cutout in longitudinal bulkhead.
6. Cut opening approximately 12'-0" x 10'-0" in port side shell between Fr. 7 and 9. Material to be refitted after installation of engines.
7. Remove longitudinal bulkhead from 3'-0" below deck between Fr. 7 and 9. Later to be reinstalled.
8. Remove propulsor compartment bulkheads, ladder and platform on starboard side. Material later to be modified and reinstalled for the same purpose.
9. Remove grating - later to be modified and installed.
10. Remove piping, wire ways - equipment and exhaust system. Later to be modified and reinstalled.
11. Remove VS-14G Unit to convenient location properly protected against damage.
12. Relocate VS-14G foundation to starboard side 5'-0" off centerline Fr. 7-9. Modify floors and install new bottom plate.
13. Fabricate new engine foundation and install 5'-0" off centerline on starboard side between Fr. 9 and 11 and modify floors.
14. Modify starboard side daytank and install new transverse bulkhead.
15. Move engine from centerline to new starboard side foundation.
16. Relocate engine foundation from centerline to port side 5'-0" off centerline between Fr. 7-9. Modify centerline floors.
17. Erect and modify propulsor transverse bulkhead 2'-3" forward Fr. 9.
18. Reinstall VS-14G Unit on relocated foundation on starboard side.
19. Erect longitudinal propulsor bulkhead on centerline between Fr. 7 and 2'-3" forward of Fr. 9.
20. Fabricate new VS-14G Unit foundation and install on port side 5'-0" off centerline between Fr. 9 to 11. Modify floors.
21. Install and modify existing longitudinal propulsor bulkhead and add new section on centerline between Fr. 9 and 11.

Case No. 1-1377

22. Install new VS-14G Unit on port side.
23. Fabricate and install new transverse propulsor bulkhead.
24. Install new 12V-71N Engine.
25. Fabricate and install new sea chest for new engine.
26. Modify and install platform and ladder.
27. Modify and reinstall piping systems, equipment, wire ways, controls and exhaust systems.
28. Reinstall longitudinal bulkhead 10'-0" off centerline port side Fr. 7-9.
29. Reinstall port shell plating.
30. Cleanup machinery room.
31. Paint machinery room and steel work.
32. Test machinery and equipment.

ESTIMATED COSTS:

1. Labor and material without diesel engine and propeller unit.....	\$400,250.00
2. 12V-71N Detroit diesel F.O.B. New York.....	26,352.00
3. VS-14EG-90 "Voith-Schneider" (Exchange Rate .5815).....	153,574.00
Shipping Costs from Germany.....	11,630.00
4. Drydocking 20 days.....	14,000.00
5. Drydocking Services.....	26,000.00
6. Trials (Dock & Sea).....	22,000.00
	<hr/>
TOTAL.....	\$653,806.00
	<hr/> <hr/>

NOTE: "Voith-Schneider" Unit = DM 264.100 (German Marks)  
Exchange Rate .5815 = \$153,574.15

Case No. 1-1377

PROPOSAL NO. 2

INSTALLATION OF 12V-149 DIESEL AND VS-21G UNIT  
IN FWD ENGINE ROOM

The following job planning is taken into consideration:

1. Support main deck from tank top Fr. 7-11 with stanchions, etc.
2. Move air receiver at Fr. 9 port side off longitudinal bulkhead.
3. Move F.O. storage tank port side off longitudinal bulkhead.
4. Cut opening approximately 12'-0" x 10'-0" in port shell plate between Fr. 7 and 9. Material to be refitted after installation of engine and propeller.
5. Remove longitudinal bulkhead 10'-0" off centerline on port side, 3'0" below deck between Fr. 7-9 and later to be reinstalled.
6. Remove F.O. storage tank, later to be reinstalled.
7. Remove air receiver, later to be reinstalled.
8. Remove grating, later to be reinstalled.
9. Remove piping, wire ways - equipment and exhaust system as necessary, later to be modified and reinstalled.
10. Remove longitudinal propulsor bulkhead, 5'-0" off centerline on port side and transverse bulkhead 2'-3" fwd. Fr. 9. Bulkheads to be reinstalled later.
11. Remove VS-14G Unit and place in storage.
12. Remove 12V-71N Diesel Engine and place in storage.
13. Modify transverse bulkhead Fr. 11. Relocating 10'-0" section on centerline 12" aft and adding 12" section port and starboard side.
14. Fabricate new engine foundation and modify floors for new 12V-149N diesel.
15. Modify propeller foundation for new VS-21G unit.
16. Clean and paint engine and propeller foundation area.
17. Install new engine.
18. Install new propeller unit.
19. Erect existing propulsor longitudinal and transverse bulkheads.
20. Modify and reinstall piping systems, equipment and exhaust system.
21. Reinstall air receiver and F.O. tank.
22. Reinstall longitudinal bulkhead on port side.
23. Reinstall port shell plating.
24. Reinstall wire ways and controls.
25. Cleanup machinery room.
26. Paint Machinery room.
27. Test machinery and equipment.

Case No. 1-1377

ESTIMATED COSTS:

1. Labor and material without diesel engine and propeller unit.....	\$255,600.00
2. 12V-149N Detroit diesel F.O.B. New York.....	80,000.00
3. VS-21G-11-135 "Voith-Schneider".....	310,695.00
Shipping Costs from Germany.....	34,200.00
4. Drydocking 15 days.....	10,600.00
5. Services.....	21,000.00
6. Trials (Dock & Sea).....	22,000.00
	<hr/>
TOTAL.....	\$734,095.00
	<hr/> <hr/>

NOTE: "Voith-Schneider" Unit = DM 534.300 (German Marks)  
Exchange Rate .5815 = \$310,695.45

PROPOSAL NO. 3

INSTALLATION OF 12V-149N DIESEL AND VS-20E UNIT

ON CENTERLINE BETWEEN FRAMES 11 & 13

The following job planning is taken into consideration:

1. Cut opening in starboard side shell plate between Frs. 11 and 12. Material to be refitted after installation of engines.
2. Cut opening in longitudinal bulkhead - F.O. tank No. 1 - starboard side. Material to be reinstalled.
3. Move table and port welder in temporary storage - To be reinstalled later.
4. Remove longitudinal bulkhead - starboard side 10'-0" off centerline between Frs. 11 and 12. Later to be reinstalled.
5. Relocate machine shop to cable compartment starboard side between Frs. 20 and 22.
6. Remove 10'-0" section from transverse bulkhead - 6" fwd. of Fr. 12 - Measured from centerline.

Case No. 1-1377

7. Relocate hydro-pneumatic tank.
8. Relocate control panels and power panels.
9. Relocate fresh-water pumps.
10. Relocate vacuum receiver tank.
11. Relocate priming pump.
12. Relocate battery racks.
13. Remove air compressor unit and place in temporary storage. To be reinstalled later.
14. Relocate filter separator 1'-0" to starboard side.
15. Remove exhaust piping from inboard generator.
16. Remove fuel oil - lube oil - water and air piping from generator.
17. Relocate generator 12" to port side.
18. Modify and install piping system for generator.
19. Relocate generator day tank (54" x 96") to port side aft of Fr. 13.
20. Modify centerline bulkhead to longitudinal girder from Fr. 11 to 13.
21. Relocate fresh-water supply line and ballast line at deck level along starboard side of centerline bulkhead.
22. Fabricate and install new engine foundation and modify floors Fr. 12-13.
23. Fabricate and install new propeller foundation and modify floors Fr. 11-12.
24. Fabricate and install new sea chest.
25. Install new 12V-149N diesel engine.
26. Install new VS-20E propeller unit.
27. Install new piping systems - for machinery.
28. Install new exhaust system - silencer, etc.
29. Install new insulation on exhaust system.
30. Fabricate and install new wire ways and install cables and electrical controls.
31. Fabricate and erect one (1) transverse and one (1) longitudinal propulsor bulkhead at 5'-0" off centerline on port side.
32. Modify longitudinal bulkhead Item No. 4 as propulsor bulkhead for starboard side.
33. Fabricate and install new day tank on inboard side of sloping bulkhead aft of Fr. 11.
34. Fabricate and install operating platform, grating and checkered plate.
35. Reinstall table and portable welder along bulkhead 11 starboard side.
36. Reinstall longitudinal bulkhead Item No. 2.
37. Reinstall starboard side shell plate.
38. Cleanup machinery space and F.O. tank No. 1.
39. Paint machinery space and steel work.
40. Test machinery and equipment.

Case No. 1-1377

ESTIMATED COSTS:

1. Labor and material without diesel engine and propeller unit.....	\$408,200.00
2. 12V-149N Detroit diesel F.O.B. New York.....	80,000.00
3. VS-21G-11-135 "Voith-Schneider".....	310,695.00
Shipping Costs from Germany.....	34,200.00
4. Drydocking 15 Days.....	10,600.00
5. Services.....	23,000.00
6. Trials (Dock & Sea).....	22,000.00
	<hr/>
TOTAL.....	\$888,695.00
	<hr/> <hr/>

NOTE: "Voith-Schneider" Unit price calculated as per Exchange Rate - PROPOSAL NO. 2.

PROPOSAL NO. 4

INSTALLATION OF TWO 12V-71N DIESEL AND TWO VS-14G UNITS

IN AREA NOW OCCUPIED BY FRESH-WATER TANKS

The following job planning is taken into consideration:

1. Cut opening in starboard side shell plate between Fr. 14 and 15 1/2 and from tank top to main deck.
2. Cut opening in starboard side longitudinal bulkhead 20'-0" off centerline Fr. 14 and 15 1/2.
3. Remove piping and supports from fresh-water tank.
4. Remove starboard side fresh-water tank from hull.
5. Remove tank foundation and chocks and install in starboard side ballast tank between Fr. 18 1/2 and 20.
6. Install new W.T. door in centerline bulkhead.
7. Fabricate 2 new engine foundations
8. Fabricate 2 new propeller foundations.

Case No. 1-1377

9. Install starboard side engine and propeller foundations and modify floors.
10. Fabricate and erect new 500 gal. day tank at centerline and transverse bulkhead 14.
11. Install new diesel engine.
12. Install new propeller unit.
13. Fabricate and erect one (1) longitudinal and one (1) transverse propulsor bulkhead.
14. Fabricate and install new sea chest.
15. Install new piping systems. Fresh-water, raw water, lube oil, fuel oil and air.
16. Install new exhaust piping, silencer and insulation.
17. Fabricate and install new wire ways, install cables, electrical controls and panels.
18. Fabricate and install new operating platform, grating and checkered plate.
19. Reinstall longitudinal bulkhead Item No. 2.
20. Reinstall starboard side shell plate Item No. 1.
21. Cleanup machinery space and ballast tank No. 7.
22. Paint machinery space and steel work.
23. Cut opening in starboard side shell plate between Fr. 18 1/2 and 20.
24. Cut opening in starboard longitudinal bulkhead, 20'-0" off centerline Fr. 18 1/2 and 20.
25. Reinstall fresh-water tank.
26. Reinstall fresh-water piping and supports.
27. Reinstall longitudinal bulkhead.
28. Reinstall starboard side shell plate.
29. Cleanup water tank compartment and ballast tank.
30. Paint compartment and steel work.
31. Test fresh-water tank and fresh-water system.
32. Repeat Item 1 through 31 on port side.
33. Test new and relocated machinery and equipment.

ESTIMATED COSTS:

1. Labor and material without diesel engines and propeller units.....	\$ 730,000.00
2. 2- 12V-71N Detroit diesels F.O.B. New York.....	52,704.00
3. 2- VS-14EG-90 "Voith-Schneider".....	307,148.00
Shipping Costs from Germany.....	23,260.00
4. Drydocking 30 days.....	20,300.00
5. Services.....	35,000.00
6. Trials (Dock & Sea).....	22,000.00
	<hr/>
TOTAL	\$1,190,412.00
	<hr/> <hr/>

NOTE: "Voith-Schneider" Unit price calculated as per Exchange Rate - PROPOSAL NO. 1.

Case No. 1-1377

The above estimated cost figures are only based on information which could be extracted from the drawings, documents and photographs listed above, without the undersigned having had the benefit of viewing the barge for general orientation.

Certain dimensions of the vessel's structural hull arrangement and machinery compartments, which were essential for cost estimating purposes and which were not clearly indicated in the drawings, were determined by method of proportionment and/or estimation.

Additional technical data and price information required on the subject of the "Voith-Schneider" propulsion unit and prime movers were acquired from the U.S.A. "Voith-Schneider" representative and a "Detroit" diesel-distributor on a confidential basis.

The estimated costs are based on the assumption that the work will be carried out in a medium size shipyard with a billing rate of approximately \$25.00 per hour.

With this letter we are returning to your office all the documents loaned to us.

We trust that you will find the foregoing satisfactory.

Very truly yours,



Norbert H. Laudorn  
Chief, Estimating Division

NHL:ck  
Enclosures

APPENDIX B

DESCRIPTION OF WORK TO BE PERFORMED  
SPECIFICATIONS OF KEY ITEMS OF PURCHASE

DESCRIPTION OF WORK TO BE PERFORMED AND SPECIFICATION OF  
KEY ITEMS OF PURCHASE

1.0 DESCRIPTION OF WORK TO BE PERFORMED

The intent of the work described herein is to improve the speed and maneuvering characteristics of the barge "SEACON" through the installation of an additional Detroit Diesel Allison (DDA) 12V-71 diesel engine and a Voith-Schneider (V-S) Model 14G cycloidal propulsor in the compartment between Frame 7 and Frame 11 5'-0" off the centerline on the port side. The present DDA 12-71 engine and V-S 14G propulsor are to be moved from their present centerline position and relocated 5'-0" off the centerline on the starboard side.

Preliminary designs have considered two methods of entry for installation of the new units—through the port side and through the bottom. Final choice of the method of entry is to be made by the shipyard contractor.

Coupling of the new engine to the propulsor unit will be by Twin Disc Type HEMR fluid coupling and Twin Disc MG-514 3:1 marine reduction gear.

The exhaust system of the relocated existing engine will be re-run in the region of the Forward Engine Room thence following approximately its present path.

An exhaust system including an exhaust muffler of design and capacity approved by the diesel engine manufacturer will be installed from the new engine running aft from the Forward Engine Room through the Generator Room and up the present uptake. Arrangement of the exhaust piping in the uptake will be adjusted to accommodate the additional pipe.

The existing foundations for the present centerline engine and propulsor will be removed. A WT CVK 3'-0" in depth will be installed between Frame 7 and Frame 11. New foundations for both port and starboard engines and propulsors will be installed using the present design and scantlings insofar as practicable. Removed steelwork may be reinstalled as appropriate at the discretion of the shipyard contractor.

The present longitudinal bulkheads port and starboard of the forward propulsor unit and forming the longitudinal boundaries of the Forward Propulsion Room are to be removed. The transverse bulkhead forming the aft boundary of the Forward Propulsion Room is to be partially removed to the 3'-0" level.

A new floor is to be constructed by utilizing the remaining section of the bulkhead with an addition extending outboard to the WT bulkheads 10'-0" off centerline.

The present air compressors located in the Forward Engine Room are to be relocated in the port side compartment presently designated as Photo Lab. Compressed air service for starting the diesel engines is to be provided to each engine.

The present day tank on the starboard side in the Forward Engine Room and outboard of the Forward Propulsion Room between Frames 7 and 8 will be removed. Two new day tanks, one servicing each engine, are to be constructed in the space on the starboard side bounded by the starboard bulkhead of the Forward Engine Room, the shell, and Frames 7 and 9. A low fuel oil alarm system for each day tank is to be provided.

The present Fuel Oil Fill and Transfer System is to be modified to provide service to the port and starboard engines with fill to and suction from the new Fuel Oil Day Tanks.

The present Lube Oil Storage Tank in the Forward Engine Room is to be increased in capacity from 106 gallons to 396 gallons. Use existing fill and vent lines. Provide a sight glass for inspection of tank level. Provide supply lines to the port and starboard engines, fluid coupling, marine gear and propulsors.

Upgrade the ventilation air supply to the Forward Engine Room from present 4160 cfm to 5980 cfm. Limiting local duct velocity is to be 2500 fpm. Provide 1125 cfm combustion air ducting over each engine. Upgrade the Forward Engine Room Exhaust System from 3660 cfm to 3720 cfm with limiting local duct velocities of 2500 cfm.

Provide additional electro-hydraulic controls for the new propulsor. Integrate the control system for the new propulsor unit into the existing control system. This is to provide centralized control of all engine and propulsor units from the Bridge Control Console and the Control Room Control Console.

The drawings applicable to the modification described are listed below.

GIANNOTTI & ASSOCIATES, INC.

DRAWING NO.

78-026-200-1 SEACON/REPOWERING STUDY GENERAL ARRANGEMENT AND PRINCIPAL  
CHANGES FOR INSTALLATION OF TWO 12V-71 DIESELS AND 14G  
PROPELLER UNITS IN FWD ENGINE ROOM:

DWG (1) of (4) \_\_\_\_\_

78-026-100-1 SEACON/REPOWERING STUDY STRUCT. MODS AND FDN. FWD. PROPULSION  
UNITS:

DWG (2) of (4) \_\_\_\_\_

78-026-200-2 SEACON/REPOWERING STUDY ARRGT. DIESEL EXHAUST SYST. FOR ADDITIONAL  
FWD PROPULSION UNIT:

DWG (3) of (4) \_\_\_\_\_

78-026-200-3 SEACON/REPOWERING STUDY MODS TO SEAWATER COOLING SYSTEM

DWG (4) of (4), Sheet #1 of 2

78-026-200-4 SEACON/REPOWERING STUDY MODS TO FUEL OIL FILL & TRANSFER SYSTEM  
DWG (4) of (4), Sheet #2 of 2

## 2.0 SPECIFICATION OF PRINCIPAL ITEMS OF PURCHASE

### 2.1 DIESEL ENGINE

One (1) Detroit Diesel Allison Model 12V-71, RH, marine diesel engine  
equipped as follows:

- heat exchanger cooling
- SAE #0 housing and flywheel
- Sea water circulating pump
- Pilot bored shaft coupling
- Variable Speed governor
- 24 Volt alternator
- 24 Volt lube oil pressure alarm system
- Tachometer Drive

### 2.1.1 Diesel Engine Exhaust Muffler

One (1) Maxim diesel engine exhaust muffler, Model No. 5189848, or equivalent suitable for Detroit Diesel Allison 12V-71 diesel engine exhaust system.

### 2.2 FLUID COUPLING AND MARINE GEAR

One (1) each Twin Disc fluid coupling and marine gear:

SAE #0 SAE #1 housing Model X217190B  
with splined shaft and bearing carriers

21" Model HEMR fluid coupling Model MG514  
marine gear, RH, with 3:1 reduction.

### 2.3 PROPULSOR UNIT

One (1) Voith-Schneider cycloidal propulsor;

Model 14G, 4 blade, 600 RPM input speed  
Electro-hydraulic control system, with power unit,  
valve unit, and actuator unit.  
Bridge and Control room modifications for four-  
propulsor operation.

## 2.4 ADDITIONS TO SEAWATER COOLING SYSTEM

References: J.J. Henry Co., Inc. DWG: 1736-500-10; Rev. C  
Giannotti & Associates, Inc. DWG: 78-026-200-2

	QUANTITY		
P1	82'	2½" Pipe	.085 THK
P2	15'	3½" Pipe	.095 THK
P3	40'	6" Pipe	.134 THK
P13	17'	3/4" Pipe	.065 THK
F5	3	6" TEE	
F9	6	2½" Elbow	
F13	3	6" x 2½" Bushing	
F14	1	6" x 5" Bushing	
F15	2	5" BHD Sleeve	
F16	4	2½" x 3½" BHD Sleeve	
F22	1	3½" TEE	
F23	1	3½" Bushing	
F25	1	4" Bushing	
F30	2	6" Elbow	
F38	1	6" Strainer	
J2	3	6" Flange	
V1	6	2½" Gate Valve	
V3	2	6" Gate Valve	
V13	1	3/4" Gate Valve	

2.5 ADDITIONS TO FUEL OIL FILL AND TRANSFER SYSTEM

References: J.J. Henry Co., Inc., DWG: 1736-500-6, Rev. A  
 Giannotti & Associates, Inc., DWG: 78-026-200-4

	QUANTITY		
P3	21'	3/4" Pipe	.113 THK
P4	109'	1/2" Pipe	.147 THK
F5	2	3/4 TEE	
F6	2	1/4 x 1/2 Reducer	
F7	2	3/8 x 1/2 Reducer	
F10	4	1/2 Half Coupling	
F32	2	3/4 Half Coupling	
J2	2	3/4 Flange	
J3	4	1/2 Flange	
V-5	2	1/2 Lift CHK Valve	
V-1	2	3/4 Gate Valve	

**END**

**FILMED**

**2-86**

**DTIC**