

AD-A163 531

REPORT ON AMPHIBIOUS/ADVANCED BASE AND COTS PROGRAMS  
(U) NAVAL FACILITIES ENGINEERING COMMAND WASHINGTON DC  
CHESAPEAKE DIV JUL 76 CHES/NAVFAC-FPO-7687

1/1

UNCLASSIFIED

F/G 15/5

NL

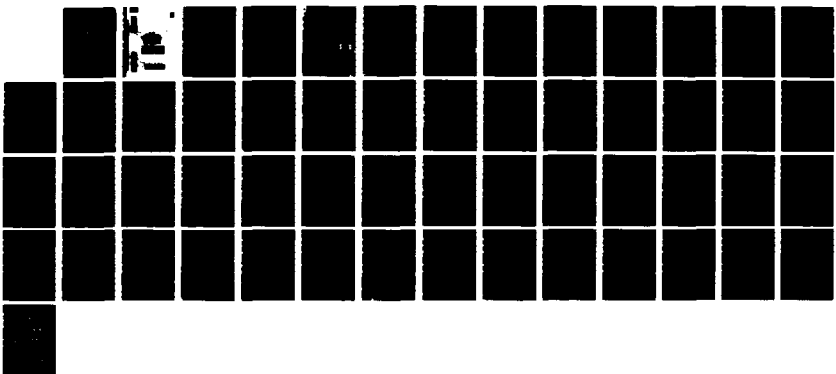

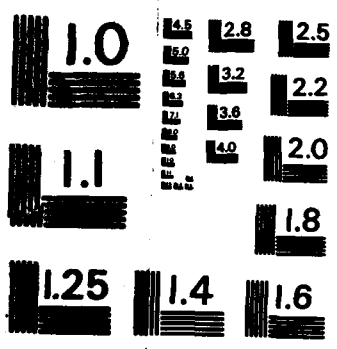

MICROCOPY RESOLUTION TEST CHART  
NATIONAL BUREAU OF STANDARDS-1963-A

REPORT  
OF  
RESEARCH/ANALYTICAL DATA  
AND  
RESULTS PROGRAM  
JULY 1976

DTIC  
SELECTED  
FEB 03 1986  
S D  
D T

AD-A163531

Unclassified

SECURITY CLASSIFICATION OF THIS PAGE

REPORT DOCUMENTATION PAGE

1a. REPORT SECURITY CLASSIFICATION  
Unclassified

1b. RESTRICTIVE MARKINGS

2a. SECURITY CLASSIFICATION AUTHORITY

3. DISTRIBUTION AVAILABILITY OF REP.  
Approved for public release;  
distribution is unlimited

2b. DECLASSIFICATION/DOWNGRADING SCHEDULE

4. PERFORMING ORGANIZATION REPORT NUMBER

5. MONITORING ORGANIZATION REPORT #  
FPO 7607

6a. NAME OF PERFORM. ORG.  
Naval Civil Engineering  
Laboratory

6b. OFFICE SYM

7a. NAME OF MONITORING ORGANIZATION  
Ocean Engineering  
& Construction  
Project Office  
CHESNAVFACENGCOM

6c. ADDRESS (City, State, and Zip Code)  
Port Hueneme, CA

7b. ADDRESS (City, State, and Zip )  
BLDG. 212, Washington Navy Yard  
Washington, D.C. 20374-2121

8a. NAME OF FUNDING ORG. 8b. OFFICE SYM

9. PROCUREMENT INSTRUMENT INDENT #

8c. ADDRESS (City, State & Zip)

10. SOURCE OF FUNDING NUMBERS			
PROGRAM	PROJECT	TASK	WORK UNIT
ELEMENT #	#	#	ACCESS #

11. TITLE (Including Security Classification)  
Report on Amphibious/Advanced Base and COTs Program Reviews

12. PERSONAL AUTHOR(S)

13a. TYPE OF REPORT 13b. TIME COVERED  
FROM TO

14. DATE OF REP. (YYMMDD) 15. PAGES  
76-07 50

16. SUPPLEMENTARY NOTATION

17. COSATI CODES		
FIELD	GROUP	SUB-GROUP

18. SUBJECT TERMS (Continue on reverse if nec.)  
COTS, Amphibious Base, Advanced Base

19. ABSTRACT (Continue on reverse if necessary & identify by block number)  
The purpose of the program review was to present the status of projects and provide the attendees and project engineers an opportunity for surfacing and discussing problem areas. The Amphibious/Advanced Base briefing was divided into two parts. On July 12, the Joint Navy/Marine Corps POL program (Con't)

20. DISTRIBUTION/AVAILABILITY OF ABSTRACT  
SAME AS RPT.

21. ABSTRACT SECURITY CLASSIFICATION

22a. NAME OF RESPONSIBLE INDIVIDUAL  
Jacqueline B. Riley  
DD FORM 1473, 84MAR

22b. TELEPHONE 22c. OFFICE SYMBOL  
202-433-3881

SECURITY CLASSIFICATION OF THIS PAGE

**BLOCK 19 (Con't)**

was presented and on July 13, the ALSA (Amphibious Logistic Support Ashore) program was reviewed. The COTS (Container Offload and Transit System) program was reviewed on July 14. The program reviews were viewgraph, slide, and motion picture presentations by project engineers and consisted of project descriptions, past, present and future efforts.

UNCLASSIFIED

①

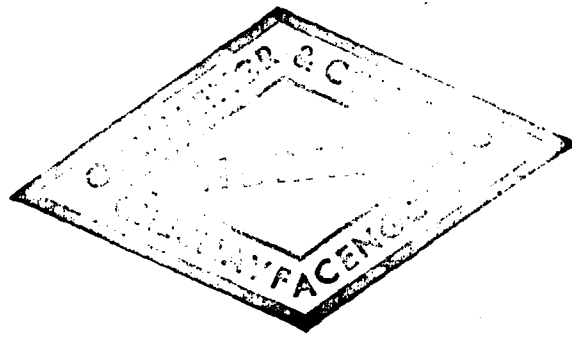

COMMANDING OFFICER  
CHESAPEAKE DIVISION  
NAVAL FACILITIES ENGINEERING COMMAND  
BLDG 57, WASHINGTON NAVY YARD  
WASHINGTON, D.C. 20374

REPORT ON AMPHIBIOUS/ADVANCED BASE AND  
COTS PROGRAM REVIEWS

JULY 1976

DTIC  
ELECTE  
S FEB 03 1986 D  
D

COMMANDING OFFICER  
CHESAPEAKE DIVISION  
NAVAL FACILITIES ENGINEERING COMMAND  
BLDG 57, WASHINGTON NAVY YARD  
WASHINGTON, D.C. 20374

DISTRIBUTION STATEMENT A  
Approved for public release  
Distribution Unlimited

86 2 3 017

UNCLASSIFIED

THIS REPORT IS A RESULT OF A PROGRAM REVIEW  
HELD AT CEL IN JULY 1976. A COPY OF THIS  
REPORT IS BEING PLACED IN THE FPO-1 LIBRARY  
BECAUSE OF THE INFORMATION CONTAINED HEREIN  
ABOUT THE AMPHIBIOUS/ADVANCED BASE PROGRAM  
AND THE COTS PROGRAM.

TIMOTHY F. SULLIVAN



Accession For	
NTIS CRA&I	<input checked="" type="checkbox"/>
DTIC TAB	<input type="checkbox"/>
Unannounced	<input type="checkbox"/>
Justification .....	
By .....	
Distribution /	
Availability Codes	
Dist	Avail and/or Special
A-1	

## TABLE OF CONTENTS

	PAGE
1.0 Introduction	1
1.1 Participants	1
1.2 Amphibious Operational Requirement	1
2.0 Amphibious/Advanced Base Program Review	1
2.1 Joint Navy/Marine Corps POL Program	1
2.1.1 POL Overview and "NOW" Capability	1
2.1.1.1 POL Program	2
2.1.1.2 "NOW" Capability	2
2.1.1.3 Developing Capability	2
2.1.2 SPM Fuel Buoy	2
2.1.3 Hoses and Pipelines	3
2.1.4 POL Storage	3
2.1.5 Propellant Anchors for SPM Fuel Buoy	3
2.2 Amphibious Logistic Support Ashore (ALSA) Program	4
2.2.1 Dozer Blade Control Kit	4
2.2.2 Soils Technology and Surfacing	4
2.2.3 PALCON	5
2.2.4 Cargo Transfer	5
2.2.5 LASH/SEABEE Lift of USMC Equipment	5
2.2.6 Expeditionary Hangar	5
2.2.7 TACOSS XI and XII	5
2.2.8 Remote Control Firefighting Module and Berm	5
2.2.9 Expeditionary Site Sanitation	6
3.0 COTS Program	6
3.1 COTS Overview	6
3.2 Elevated Causeway	6
3.2.1 Lift System/Spudwells	8
3.2.2 Side Connectors for Pontoon Causeways/ Structural Aspects	8
3.2.3 End Connectors	9
3.2.4 Fendering	9
3.2.5 DDR&E LOTS Tests	10
3.3 Powered Causeway	10
3.4 Side Loadable Warping Tug (SLWT)	11
3.5 RO/RO (Roll on/Roll off)	12
3.6 Temporary Container Discharge Facility (TCDF)	12
3.6.1 Overview	12
3.6.2 Crane Machinery Analysis	13
3.6.3 Crane Boom Analysis: T&E of the P&H 6250	14
3.6.4 Crane Survey; Human Factors Aspects; Power Tagline	14

	PAGE
3.6.5 Anti-Pendulation Bridle	15
3.6.6 Test and Evaluation of 4100W	15
3.6.7 Tethered Float Breakwater (TFB)	16
4.0 Recommendations	16
Appendix A: Amphibious/Advanced Base Program Briefing Schedule	
Appendix B: COTS Program Briefing Schedule	
Appendix C: Attendees at Amphibious/Advanced Base Briefing	
Appendix D: Attendees at COTS Briefing	

## 1.0 INTRODUCTION

The purpose of the program review was to present the status of projects and provide the attendees and project engineers an opportunity for surfacing and discussing problem areas. The Amphibious/Advanced Base briefing was divided into two parts. On July 12, the Joint Navy/Marine Corps POL program was presented and on July 13, the ALSA (Amphibious Logistic Support Ashore) program was reviewed. The COTS (Container Offload and Transit System) program was reviewed on July 14. The program reviews were viewgraph, slide, and motion picture presentations by project engineers and consisted of project descriptions, past, present and future efforts. Appendices A and B are the agendas for the Amphibious/Advanced Base and COTS briefings respectively.

### 1.1 Participants

The following organizations were represented at the program reviews:

Military:	PHIBCB-1, PHIBCB-2, NBG 2, HQMC, OHSD(I&L), MCDEC
Gov't:	NAVFAC, NUC, CEL, CESO, MERADCOM, NAVSEA, NAVMAT, NWHC, NCSL, NSRDC
Industry:	EG&G, SEA INC

Appendices C and D are a list of attendees for the Amphibious/Advanced Base and COTS briefings respectively.

### 1.2 Amphibious Operational Requirement

The Operational Requirement (OR) for Amphibious operations states that all systems have the capability of operating in sea state 3, 4 knot current, 30 knot wind and be capable of surviving sea state 5. The project engineers are using these criteria for design purposes.

## 2.0 AMPHIBIOUS/ADVANCED BASE PROGRAM REVIEW

The following is a brief summary of the projects in the Joint Navy/Marine Corps POL program and the ALSA program.

### 2.1 Joint Navy/Marine Corps POL Program

#### 2.1.1 POL Overview and "NOW" Capability

This presentation was given by Mark Hollan (CEL, Av 360-5973). The objective of the Joint Navy/Marine Corps POL program is to maintain and enhance POL system capability through the 1980's.

A typical amphibious assault scenario is as follows. Forces are placed ashore on H-hour of D-day. By D+1, the assault forces have

secured the beach. Between D+1 and D+5, an LST (2500 dwt) moored 5000 ft offshore, delivers fuel to the beach. From D+5 to D+15, the LST moor is replaced by a single point moor (SPM) 10,000 ft offshore. The SPM is capable of holding a 38,000 dwt tanker (MSC) during fuel offload.

#### 2.1.1.1 POL Program

- o Offshore subsystems
  - a. POL storage
  - b. Propellant Embedment Anchors (PEA's)
  - c. Single Point Moor (SPM) Buoy
  - d. Transfer Capability
- o Onshore subsystems
  - a. Amphibious Logistics Support Ashore (ALSA)
  - b. Transfer Capability
  - c. Fuel quality capability

#### 2.1.1.2 "NOW" Capability

The present capability is to single point moor a 2500 dwt tanker (LST) 5000 ft offshore and deliver fuel with hoses and pipe to "tank farms" onshore. The "tank farms: are large bladders enclosed in berms (dirt shoulders)." There are two kinds of "tank farms": AAFS (Amphibious Assault Fuel System) which stores mo-gas and diesel fuel; and TAFDS which is used to store jet fuel.

#### 2.1.1.3 Developing Capability

After D+5, the single point LST moor will be replaced by a SPM buoy. Mooring legs will be anchored using PEA's and be capable of holding a 38,000 dwt tanker (MSC). A fuel pumping station will be established between the SPM buoy and shore. Fuel lines from the pumping station will deliver fuel to the AAFS and TAFDS ashore. Relative to the "now" capability, the larger tanker is capable of delivering more fuel ashore and the SPM buoy and pumping station are capable of offloading the fuel faster from the tanker.

#### 2.1.2 SPM Fuel Buoy

This presentation was given by Hugo Conti (CEL, Av 360-5592). SPM stands for Single Point Moor. The advantage of the SPM buoy is that larger tankers can be moored and consequently more fuel delivered per vessel. The system consists of floating hoses, propellant embedment anchors, mooring lines, offload lines and the buoy itself. A mooring

force of 250 KIPS has been determined for a 70,000 dwt tanker in sea state 5. 4kt. current and 30kt wind. The recommended number of mooring legs is currently being determined.

### 2.1.3 Hoses and Pipelines

This presentation was given by Norm Clark (CEL, Av 360-5226). The present system is capable of delivering 500 gpm of fuel to the beach. Currently 6 inch pipe, in 30-35 ft sections is pulled out to the LST which is 5000 ft from the beach. In order to increase the flow rate to shore, 8 inch pipe is being considered. Pipe material, size, weight, and internal roughness are some of the factors being looked at for 8 inch pipe. A study was made to identify and determine the magnitude of the forces on the submerged pipe. It was determined that current forces were the most dominant.

Since the developing capability calls for 10,000 ft of pipe between the SPM buoy and shore, LCDR Bill Clarke of PHIBCB-1 questioned the capability of a warping tug to pull 10,000 ft of 8 inch pipe. Right now, a side loadable warping tug has difficulty in pulling 5000ft of 6 inch pipe.

### 2.1.4 POL Storage

This presentation was given by Norm Albertsen (CEL, Av 360-5792). The project is looking at bladders, a mid-range system and a long range system for storing fuel at sea and onshore. Right now, the Dracone bladder shows the most promise for storing fuel at sea. The mid-range system is divided into two subsystems: onland and offshore tanks. For onland containers, bags, and FRP (fiberglass reinforced pad) tanks are being looked at. For offshore containers, LASH barges, commercial tank barges, and T-2 tankers are being looked at. Right now, because of their surprisingly low cost, the commercial tank barges look the most promising. The long range system is similarly divided into onland and offshore containers. In onland containers, coil welded steel tanks with a capacity of 1 1/4 million gallons are being looked at. In offshore containers, barges are being looked at for storing fuel on the surface and bladders and bottom resting structures for submerged storage.

A Dracone test is planned. The mid-range analysis is continuing and the Storage Development Plan is being updated.

### 2.1.5 Propellant Anchors for SPM Fuel Buoy

This presentation was given by Dan True (CEL, Av 360-4656). The 100 KIP Propellant Embedment Anchor (PEA) will be used to moor the SPM Fuel Buoy. The 100 KIP anchor is a different configuration than the 100 KIP anchor used at Diego Garcia. The tripod has been replaced by a reaction cone and a touchdown rod has been added to initiate firing in lieu of firing electrically from the surface.

A conceptual scenario was presented for deploying PEA's for installing a SPM Fuel Buoy. The PEA's are preassembled less the propellant charge and stored on the LST. The anchor are offloaded from the LST with a crane onto small sleds on a warping tug. The small sleds are maneuvered on the deck with the warping tug winch. The propellant charge is loaded just before the anchor is lowered over the side of the warping tug. An alternative to the small sled would be a small forklift.

The PHIBCB's questioned the feasibility of loading the anchors on the warping tug alongside the LST. It was felt that the warping tug would be damaged. Also, the feasibility of having a small forklift maneuver the anchors on the deck of the warping tug was questioned.

## 2.2 Amphibious Logistic Support Ashore (ALSA) Program

This presentation was an overview of ALSA given by Dave Lambiotte (CEL, Av 360-4085). The ALSA program is directed toward setting up: Beach Support Areas (BSA), Logistic Support Areas (LSA), and forward areas; cargo transfer and storage: small, intermediate, large, and very large cargo; horizontal construction: clearing land, real estate planning, constructing roads and airstrips; vertical construction: shelters, fuel storage, medical, dental, and laundry facilities. The current effort is directed toward defining ALSA, developing an ALSA plan, and developing a RDT&E plan for ALSA. The ALSA environment is from D to D + 30.

The program has six subsystems: (1) POL (transferring fuel ashore to "tank farms" and then transferring the fuel from the "tank farmer" to vehicles); (2) Breakbulk Cargo (transfer and storage of small to intermediate size cargo); (3) Containerized Cargo (transfer and storage of large (8'x8'x20') containers); (4) Outsized Cargo (transfer and storage of very large cargo, example: causeway sections); (5) Horizontal Construction: real estate planning, clearing the land, construction roads and airstrips; (6) Vertical Construction: shelters and utilities.

### 2.2.1 Dozer Blade Control Kit

This presentation was given by Carter Ward (CEL, Av 360-5226). A laser automatically controls the height of a dozer blade. The system enables the dozer to function as a grader. In FY 77, a contract for 6 kits will be let at a cost of about 15K/kit. The Marine Corps is the customer.

### 2.2.2 Soils Technology and Surfacing

This presentation was made by Mel Hironaka (CEL, Av 360-5198). The objective of this project is to improve Marine Corps ground operation by soil identification, modification, and strengthening. The approach is to evaluate FOMAT panels in the laboratory, field fabrication and evaluation of FOMAT, develop a 5 year shelf life for AMSS chemical

components, and investigate new materials. FOMAT is a surfacing material used to construct roads and airstrips. It is sprayed directly on a graded surface. Progress includes extending a contract with Dow Chemical for developing a 5 year shelf life for AMSS chemical components, a FOMAT development report, investigation of new materials and techniques.

#### 2.2.3 PALCON

This presentation was made by Dick Seabold (CEL, Av 360-4864). A PALCON is a palletized container. The project is now in the conceptual phase. A contract for a preliminary design will be let in the near future.

#### 2.2.4 Cargo Transfer

This presentation was made by Mike Wolfe (CEL, Av 360-4865). This project is looking at mobile cranes for offloading 8' x 8' x 20' containers from beached landing craft. The containers weigh 25 tons unloaded. A statement of work has been written and a contractor should be aboard by mid-August. Delivery will be early next calendar year.

#### 2.2.5 LASH/SEABEE Lift of USMC Equipment

This presentation was made by Duane Davis (CEL, Av 360-4217). This project is concerned with lifting and offloading outsized cargo components (causeways, cranes, LARC's, POL buoy, etc.) from C-8 and C-9 class ships. J. J. Henry has designed a cantilever lift frame. A contract for fabrication of the cantilever lift frame has been awarded with delivery in August 76.

#### 2.2.6 Expeditionary Hangar

This presentation was made by Dick Seabold (CEL, Av 360-4864). The project is concerned with prefabricated aircraft hangars. The hangars have a LOCKARCH (locked arch) construction with a roof made of poly carbonate plastic panels. Test have shown that the corners of the plastic panels are susceptible to breaking during shipment and installation. Metal plates, on the corners of the plastic panels, have reduced the number of broken corners on the plastic panels.

#### 2.2.7 TACOSS XI and XII

This presentation was made by Dick Seabold (CEL, Av 360-4864). The project is concerned with developing 8' x 8' x 20' general purpose cargo containers.

#### 2.2.8 Remote Control Firefighting Module and Berm

This presentation was made by John Bayles (CEL, Av 360-5973). This project is concerned with hardware and techniques for fighting and containing fires in areas where fuel is stored.

## 2.2.9 Expeditionary Site Sanitation

This presentation was made by Ted Kuepper (CEL, Av 360-4191) and Dr. Chan (CEL, Av 360-4191). This project is concerned with providing the Marine Corps with a field unit containing a head, laundry, and shower with the capability of solid and liquid disposal. The troop enters the field unit, strips off his clothing which is laundered while the troop takes a shower. By the time the troop finishes showering (10 minutes), the clothing is laundered.

Accomplishments in FY 76 include the design and fabrication of a laundry unit, a solid waste disposal feasibility study and a study of laundry/shower waste water treatment.

The events of 13 July ended with a round table discussion between the PHIBCB's, Marine Corps and CEL. The purpose of the discussion was to develop a scenario for an amphibious landing and match resources (TOA) to events taking place in the scenario. There was difficulty in developing a day to day scenario from D-day to D+15. The scenario was never completely developed. The discussion degraded into small talk and the day ended.

The attempt at a round table discussion surfaced an interesting problem. The Marine Corps generates a requirement for a particular capability and CEL responds to the requirement. The PHIBCB's have the responsibility of getting the resulting hardware ashore. The PHIBCB's have limited resources (TOA) in terms of manpower and craft. Apparently, there isn't anyone taking a systems approach in integrating developed hardware with existing PHIBCB capability.

## 3.0 COTS PROGRAM

### 3.1 COTS Overview

An overview of the COTS Program was presented by Mr. R. Towne (CEL, Av 360-5416). The program consists of three subsystems: ship unloading subsystem (platforms and crane); ship-to-shore subsystem (elevated causeway, offshore transfer platform, side loadable powered causeway and warping tug); and a logistic support ashore (LSA) subsystem (interfaces with ALSA in establishing the logistics support area ashore).

### 3.2 Elevated Causeway

Basically, the elevated causeway consists of pontoon causeway sections connected together and elevated on pilings. The components include a lift system for elevating the causeway sections, spudwells for fastening the elevated causeway sections to piles, side and end connectors for holding the causeway sections together and a fendering system for offloading craft alongside the elevated causeway. In 1977, there will be a joint Army/Navy demonstration (LOTS) of the elevated causeway system at Ft. Story, VA.

### Elevated Causeway Performance Goals:

- o Install elevated causeway pier from beach to point offshore suitable for lighterage operations.
  - causeway/container crane operations: handle 20-ft (22-ton) and up to and including 40-ft (35-ton) containers at 40-ft radius.
  - container transfer rate: 10-12 containers per hour from lighterage to shore; use multiple components to meet greater demands.
- o Use existing Navy assets augmented by commercial hardware to the maximum extent practical.
- o Be compatible with cargo from existing containerships and other container capable ships, such as RO/RO ships, bargeships, and other cargo ships.
- o Provide limited container handling capability (LO/RO and RO/RO at an early time frame).
- o Introduce elevated causeway components into fleet by end of FY 78.

### Elevated Causeway Operational Criteria:

- o Sustained operations in a sea state 3 (significant wave height, 5-foot) with 30 knot winds, 4 knot current.
- o Provide 20-foot water depth at pierhead.
- o 7-foot surf and 8-foot tide.
- o Survive in sea state 6 (significant wave height, 20 feet) with 75 knot winds, 4 knot currents.
- o Survive hurricane forces, given 24 hours warning, and be capable of being operational within 48 hours following the storm.

### Elevated Causeway Configuration Objectives:

- o Components are to be transportable by LST and commercial carriers such as bargeships.
- o Provide for lighterage operation/cargo handling and transfer beyond the surf zone.
- o Capable of being installed in breakers/swells up to 7 feet; survive in swells up to 15 feet.

- o Accessories - Double bitts for lighterage tie-up; DE-30 pile hammer and leads; ladder for crew access between floating and elevated sections; communications from pierhead to lighterage and beach; piling for elevating

- o Side Connectors

- o End Connectors (Flexors)

Current Developments:

Modifications recommended from Phase II tests at Coronado. Thirty-one (31) items were discussed or recommended. All of the items have been investigated and included in the FY 76 development program.

Major items include:

- o Improved method for temporary and permanent attachment between pile and spudwell: Two approaches: contract with outside industry; CEL development

- o Modify turntable to add air power

- o Modify jack system to simplify system

- o Modify lift padeyes on spudwells for LST side load

- o Safety ladder for personnel

- o Modify side connector

- o Improve communications between pierhead/beach/lighters

### 3.2.1 Lift System/Spudwells

This presentation was given by Mr. C. Skaalen (CEL, Av 360-4863). The lift system consists of elevating hardware (internal spudwells, external spudwells/spudwell installation, pontoon section to pile connection); jacking system (50 ton capacity jacks and chain, power unit/control console, control console operating procedures, gimbals, pile cap adapters); pier construction methods (site survey methods, pile positioning/driving, section elevation sequence, multi-section lifts, jacking equipment transfer/installation, disconnection/connection of pontoon sections, pier survey techniques, pontoon section to pile connection, personnel organization/safety).

### 3.2.2 Side Connectors for Pontoon Causeways/Structural Aspects

This presentation was given by Billy Karrh (CEL, Av 360-4865).

The objective of the project is to develop techniques and hardware to assemble NL pontoon barges in a side-to-side arrangement to provide a floating platform.

The loads on elevated causeways are:

Dead Load: Weight

Live Loads:	Wave Loads:	Local effects Lateral effects
	Transit Loads:	Local effects - deck reinforcement Structural effects
	Container:	Local effects
	Crane Operations:	Overall effects - spudwell placement
	Mooring Loads:	Local; Lateral loads

The stress distribution of a transit load (P & H 8100 crane) on a elevated causeway has been determined and is shown in figure 1. Note, that the maximum stress is off center.

The PHIBCB's raised a question about "unique" causeway sections. Some causeway sections have spudwells and some sections have side connectors. If the PHIBCB's have a TOA for a certain number of causeways and a "unique" section is lost during a landing the problem of where do you get a "unique" section replacement comes up. The problem was not resolved at the time of the presentation.

### 3.2.3 End Connectors

The presentation was made by Hugo Conti (CEL, Av 360-5592). End connectors are used to secure causeway sections end to end. A movie was shown of the maneuvering problems and techniques being developed in connecting causeway sections end to end. It seemed that it would be very difficult to connect two causeway sections end to end in a sea state 3.

A Flexor connector is the present end connector being developed. The initial Flexor connector had a welded steel head as is shown in figure 2. Repeated failures of the welded steel head resulted in modifying the head to all cast steel. A proposed change to a sloped nose (easier mating) cast steel head is shown in figure 3.

### 3.2.4 Fendering

This presentation was given by Duane Davis (CEL, Av 360-). The principal components of the fendering system being developed are:

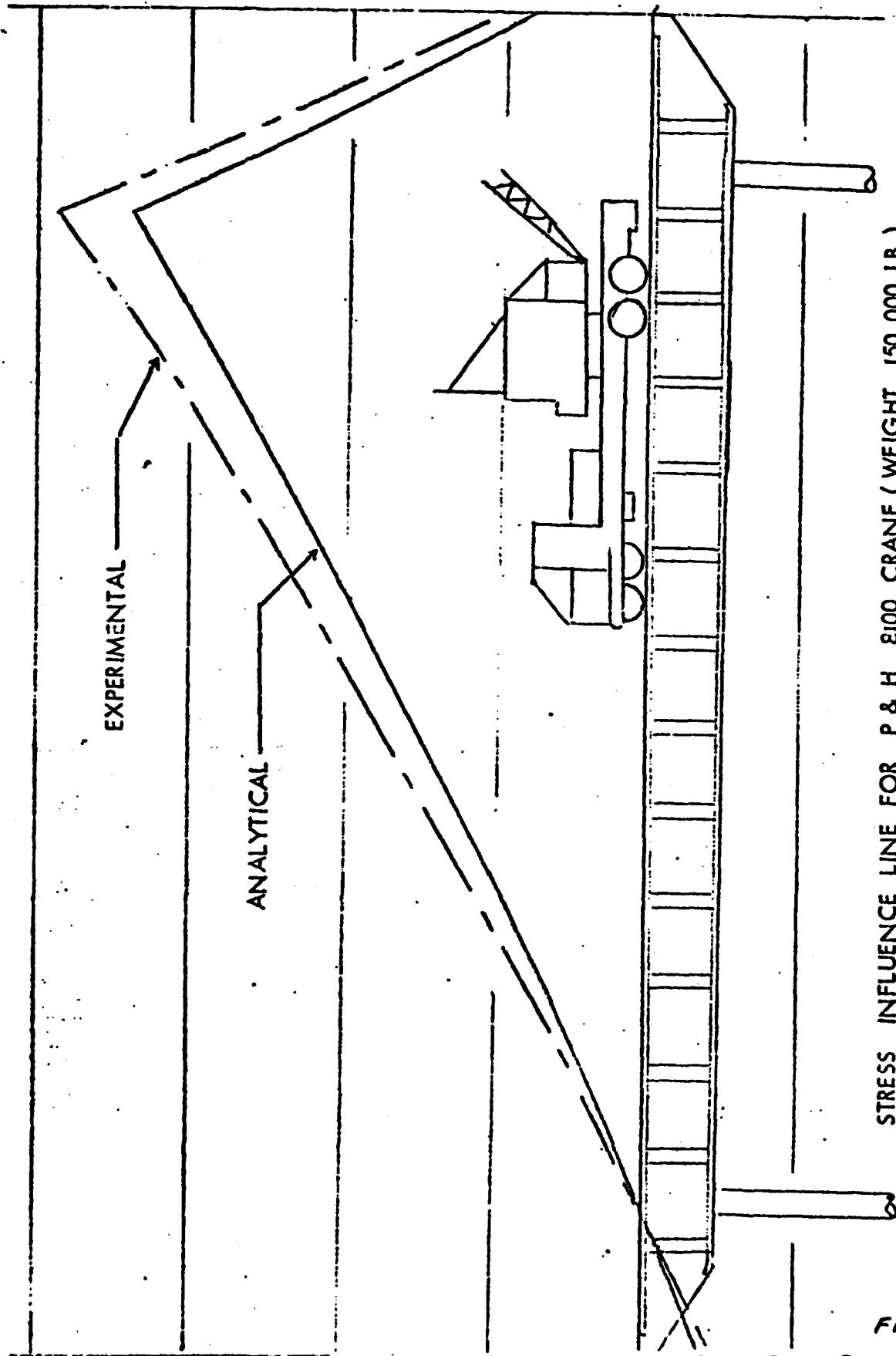

EXPERIMENTAL

ANALYTICAL

STRESS INFLUENCE LINE FOR P & H 8100 CRANE (WEIGHT, 150,000 LB.)

FIGURE 1

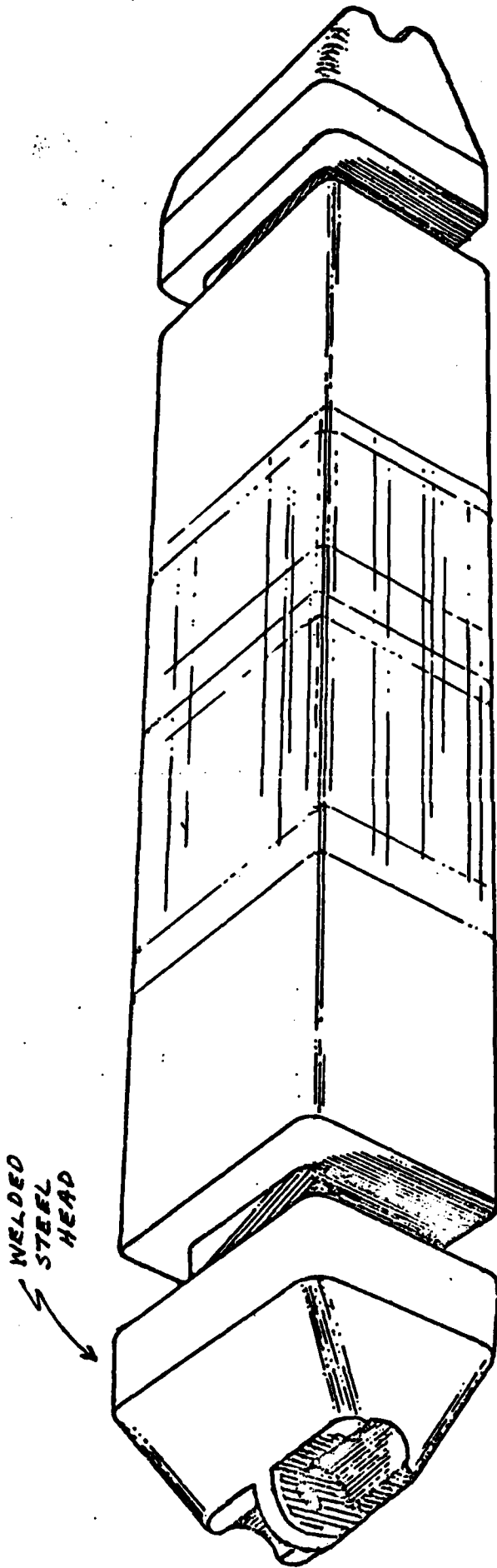

# INITIAL FLEXOR DESIGN

Figure 2 ..

TWO SIDED GUILLOTINE  
(DROPS DOWN AND  
SECURES FLEXOR  
HEAD)

CAUSEWAY  
END  
SECTION

SLOPED NOSE  
CAST STEEL HEAD

GUILLOTINE  
FEMALE  
END

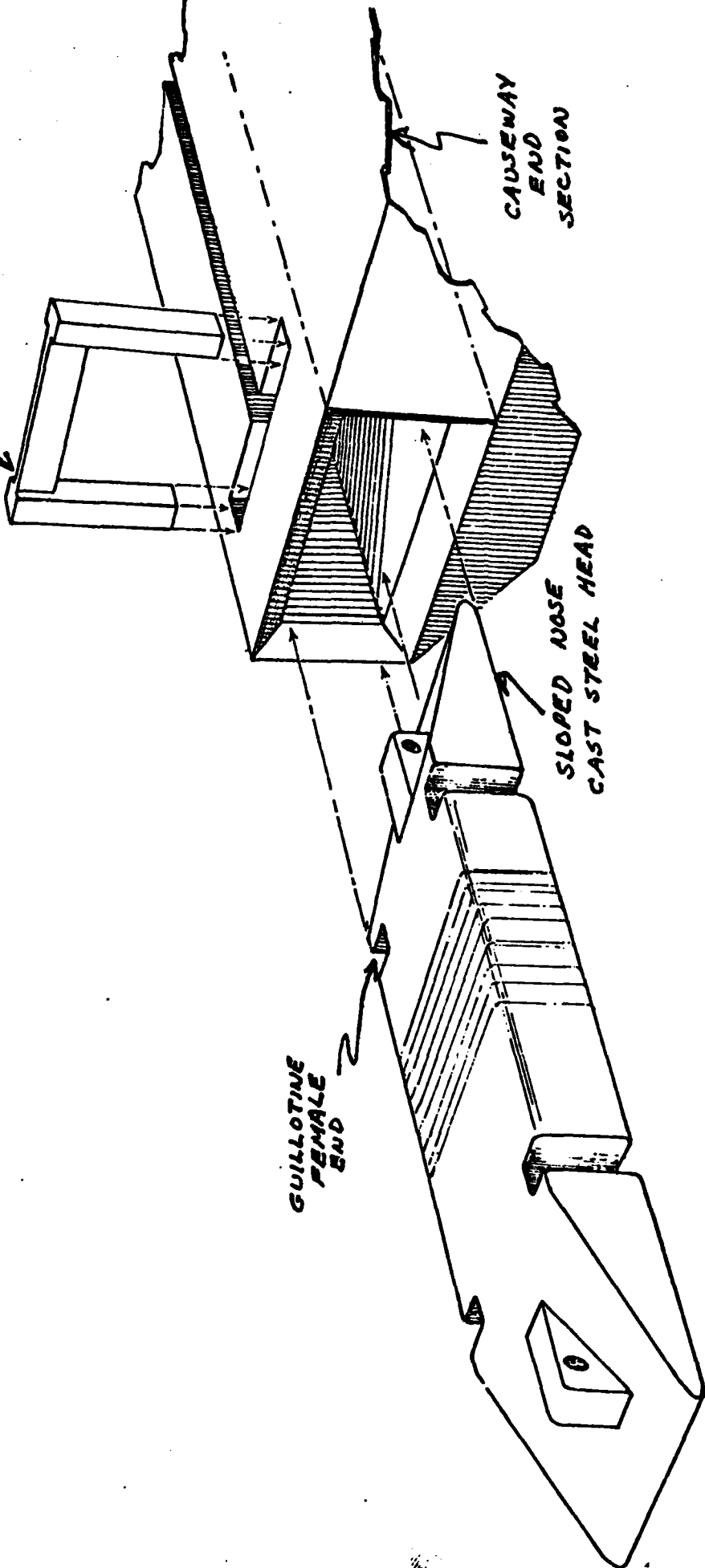

# PROPOSED NEW FLEXOR DESIGN

Figure 3

- o NL pontoon hardware
- o Internal spudwells with chafing rings
- o Foam - filled cushion
  - Seaward International
  - Samson Ocean System
- o Rigging

The performance standards for the fendering system are:

- o Compatible with elevated causeway system
- o Floating - rises and falls with tides/waves
- o Prevent contact between lighters and pier piling
- o Absorb berthing impact in state 3 seas
  - fully loaded LCU at 2 ft/sec
- o Survive waves 10 feet plus

The results of a recent test at Coronado are:

- o 4-6 hour installation time for two sections
- o Survived warping tug impact
- o Remained in place for 45 days
- o Survived 8 foot waves
- o Only minor wear/damage to cushions

The fendering system will be part of the LOTS test in 1977.

### 3.2.5 DDR&E LOTS Tests

This presentation was a movie taken during a previous LOTS test of the installation, operation, and dismantling of an elevated causeway. The LOTS tests are full scale tests of the amphibious, advanced base, and COTS subsystems. The next LOTS test is scheduled in 1977.

### 3.3 Powered Causeway

This presentation was made by Mr. S. Wang (CEL, Av 360-4863). A

powered self-propelled causeway (figure 4) is made up of 3 modules (figure 5). Each module has a forward area made of pontoon sections (figure 6). The powered causeway has been designed so that it can be loaded on the side of an LST. Weight and trim, speed, static thrust and fuel consumption data are shown in figures 7-10.

The fabrication of the water jet propulsion plant was begun in June 1976 under contract. The fabrication is scheduled to be completed in March 1977 with testing and delivery in April 1977.

The non-powered sections will be fabricated in-house and are due to be completed in August 1977.

### 3.4 Side Loadable Warping Tug (SLWT)

This presentation was given by Billy Karrh (CEL, Av 360-4865). A side loadable warping tug is a warping tug configured so that it can be loaded on the side of a 1179 class LST. The SLWT is the primary work boat during an amphibious assault.

The main components of the SLWT are pontoon causeway sections, a folding A-frame, winch, an optional lift on/off shelter, and a waterjet propulsion system.

The SLWT side loaded on a LST is shown in figure 11 along with the mission profile, configuration objectives and special features of the SLWT.

Figure 12 depicts a SLWT, and lists SLWT characteristics, estimated waterjet propulsion performance and estimated winch performance.

The SKAGIT model BU-18 marine winch has been selected for use on the SLWT. Figure 13 shows a plan and profile view of the winch with dimensions and winch characteristics.

The milestones in the SLWT development are:

	<u>Completion Date</u>
o Hull component design	Aug 76
o Analysis and design of handling gear	Aug 76
o Delivery of winch for SLWT evaluation	Aug 76
o LST design modifications for SLWT	Feb 77
o Procure new handling gear for test	Mar 77

# POWERED CAUSEWAY SECTION

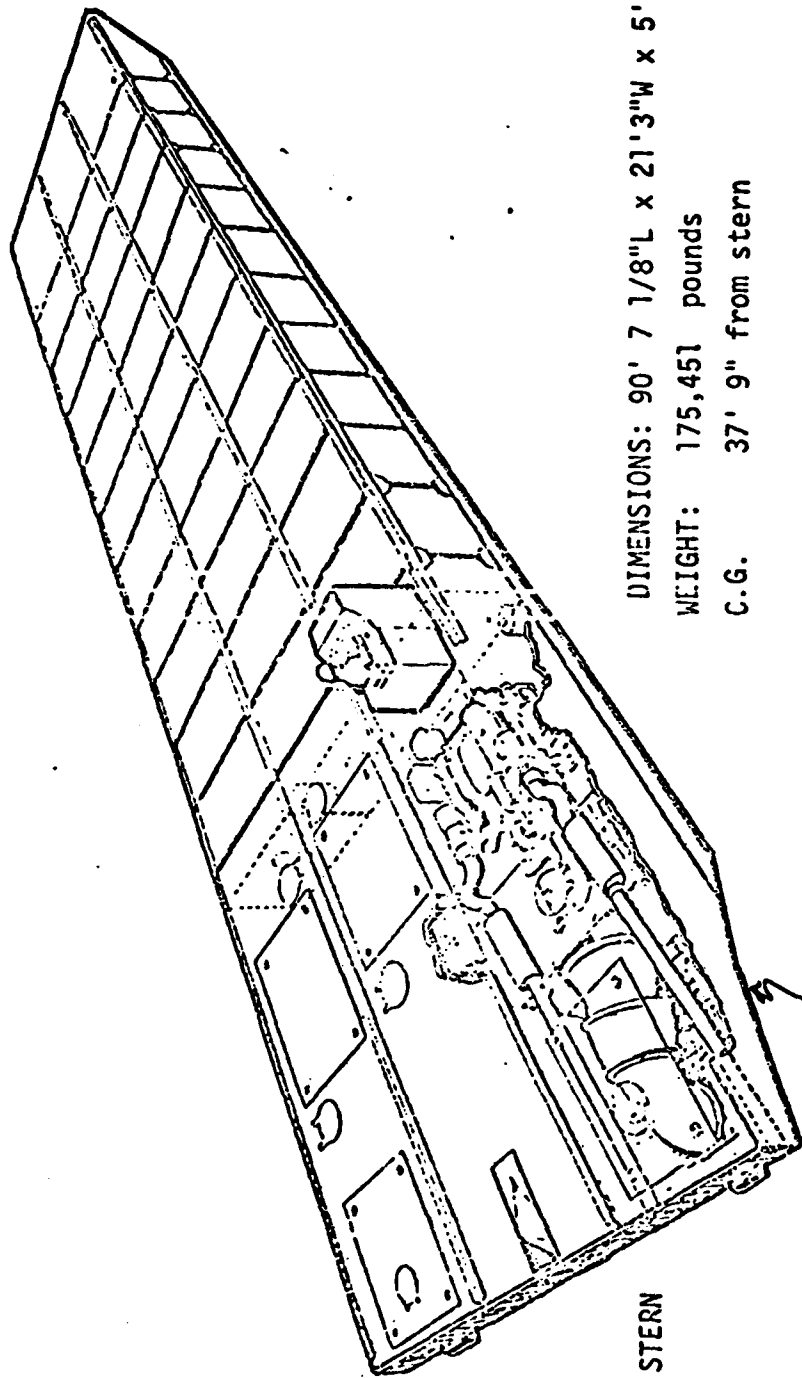

DIMENSIONS: 90' 7 1/8" L x 21' 3" W x 5' 3/8" H

WEIGHT: 175,451 pounds

C.G. 37' 9" from stern

STERN

PROPELLER  
UNIT

Figure 4

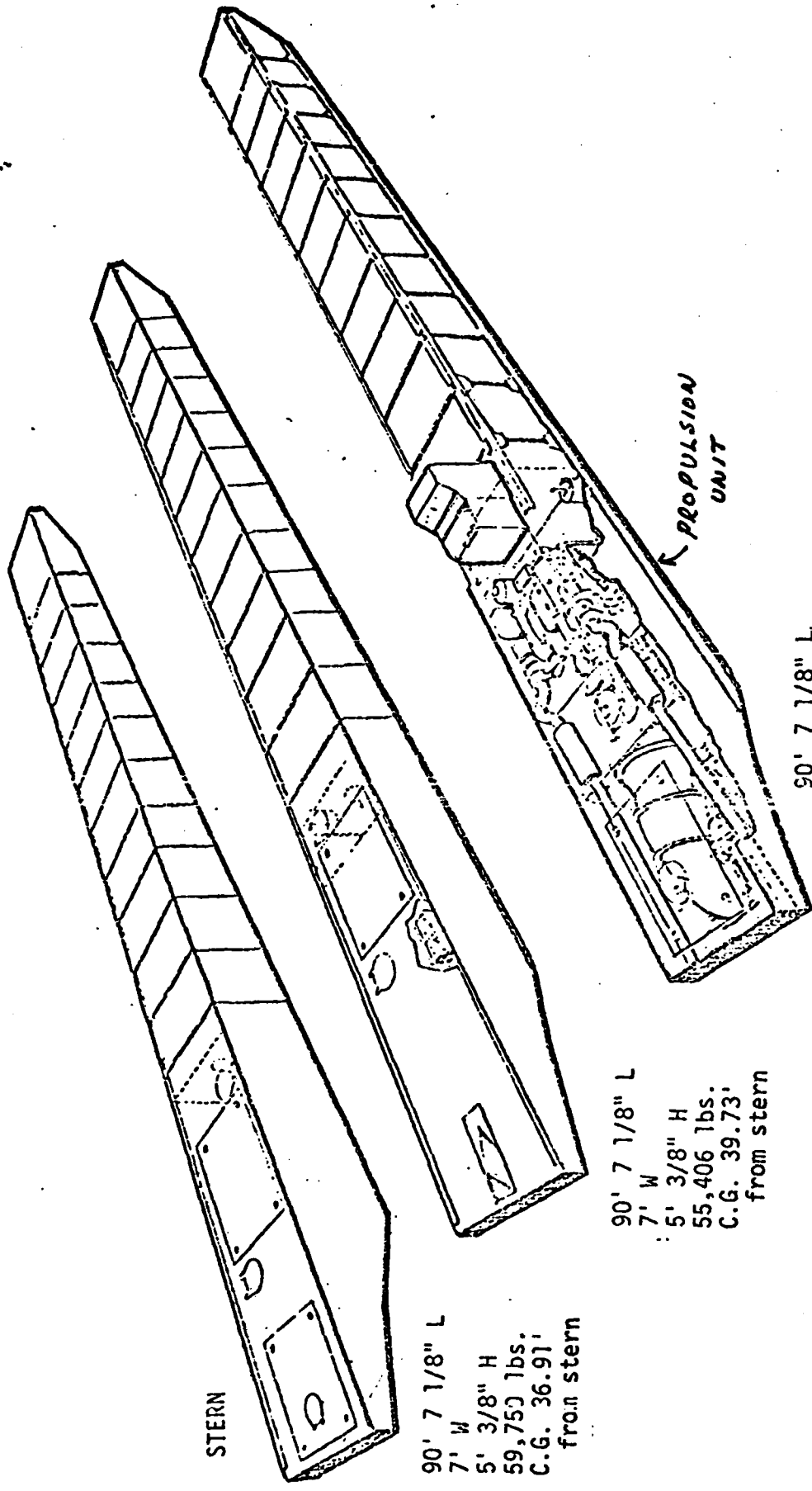

STERN

90' 7 1/8" L  
7' W  
5' 3/8" H  
59,750 lbs.  
C.G. 36.91'  
from stern

90' 7 1/8" L  
7' W  
5' 3/8" H  
55,406 lbs.  
C.G. 39.73'  
from stern

PROPULSION  
UNIT

90' 7 1/8" L  
7' W  
5' 3/8" H  
60,295 lbs.  
C.G. 36.77'  
from stern

Figure 5

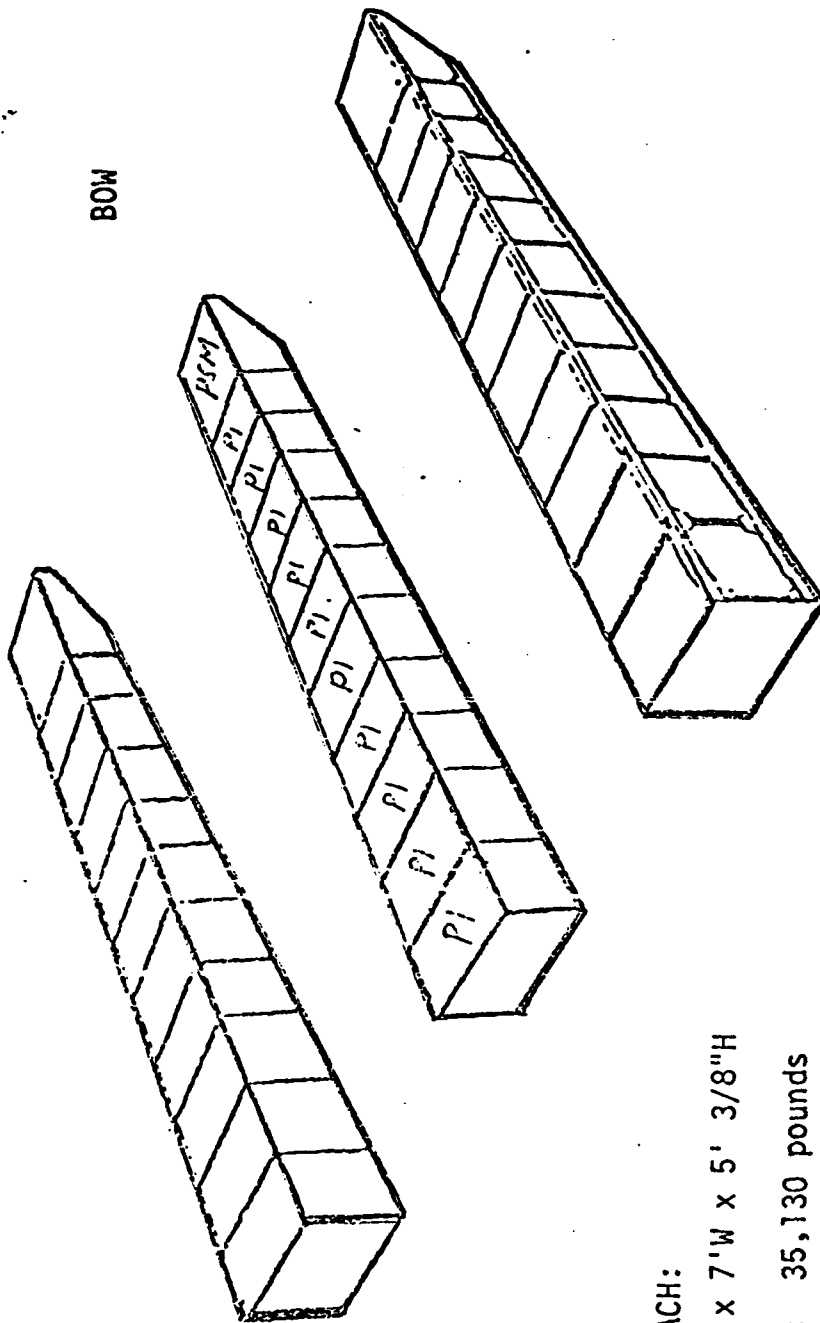

BOW

DIMENSION OF EACH:

65' 8 1/8" L x 7' W x 5' 3/8" H

WEIGHT OF EACH: 35,130 pounds

C.G. 35.93' from bow  
(54.66' from stern of PCS)

Figure 6

# WT & TRIM - OPERATING CONDITION

CONFIG.	WT. lbs	LCG fwd of stern	VCG above hull bottom	DRAFT		TRIM ANGLE
				bow	stern	
full fuel (f.f)	179,600	37.06'	2.54'	0.97'	2.68'	1.08°
f.f.+10,000 lb. ballast	189,600	38.55'	2.56'	1.24'	2.54'	0.8°
f.f.+20,000 lb. ballast	199,600	41.57'	2.60'	1.72' (20.6")	2.28'	0.4°
f.f.+30,000 lb. ballast	209,600	43.71'	2.63'	2.11'	2.11'	0°

Figure 7

# SPEED

Engine RPM	Draft	Speed, Knots		
		PCS	4 sections	12 sections
2181	25"	8.9	6.6	4.1
1500	25"	6.9	4.6	2.6
2181	48"	7.1	4.5	2.7
1500	48"	4.9	3.1	1.9

Figure 8

# STATIC THRUST

Engine RPM	fwd	astern	athwartship
2181	12,125	11,528	11,903
1800	8,255	7,848	8,104

astern = 95% fwd  
athwartship = 98% fwd

Figure 9

# FUEL CONSUMPTION

<u>Engine RPM</u>	<u>GPH</u>	<u>Fuel Reserve*, hrs.</u>
2181	46.4	3.47
1800	40.4	5.47
1500	35.0	7.86

\* Design endurance 10 hrs. Tank capacity 625 gal.

Figure 10

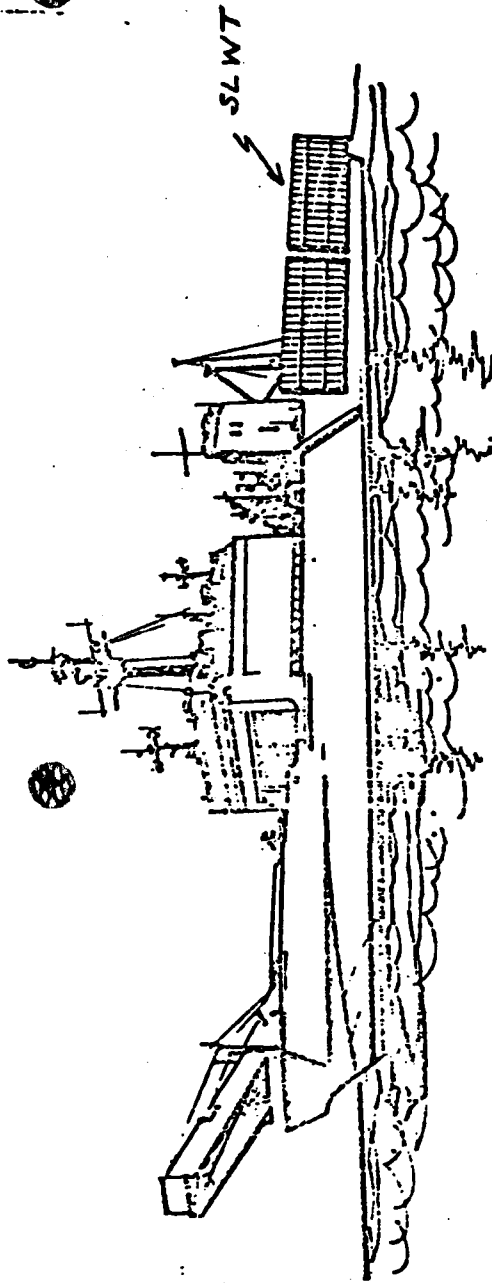

Mission Profile

Assemble, install and tend causeways

Deploy and retrieve conventional anchors to 6,000 pounds

Salvage beached causeways and landing craft

Install floating and bottom-laid POL systems

Install tanker moor

Install propellant actuated anchors to 100,000 pound resistance

Sustained capability

Tow lighters and other craft

Operate in seas and surf up to 7 feet

Configuration Objectives

Simplicity of design and fabrication

Erectable, maintainable, and field repairable by PHIBCB's

Side-loadable on 1179 Class LST

Folding A-frame

Side-loadable winch

Operational soon after launch

Lift-on/lift-off shelter (optional)

Special Features

LST side-loadable

Folding A-frame

Skid-mounted winch

Maximum propulsion efficiency in surf

Lift-on/lift-off shelter (optional)

Figure 11

**SIDE-LOADABLE WARPING TUG (SLWT)**

Estimated Characteristics

- Weight: 200,000 pounds
- Draft: Bow - 1.4 feet, stern 3.0 feet
- Length: 85 feet
- Width: 21 feet

Estimated Waterjet Propelled Performance

- Speed: 6-8 knots
- Thrust (static): Forward - 12,000 lbs, astern - 8,000 lbs, athwartship - 10,000 lbs
- Fuel Capacity: 600 gallons (10 hours operation)
- Range: 80 miles
- Steering: Independent nozzle controls (360° rotation in 6 seconds)

Estimated Double-Drum Winch Performance

- Line Pull: High speed - 10,000 lbs at 200 feet per minute  
Medium speed - 20,000 pounds at 100 feet per minute  
Low speed - 40,000 pounds at 50 feet per minute
- Drum Capacity: 1,000 feet of 1-1/8 inch wire rope.
- Special Requirement: Skid-mounted

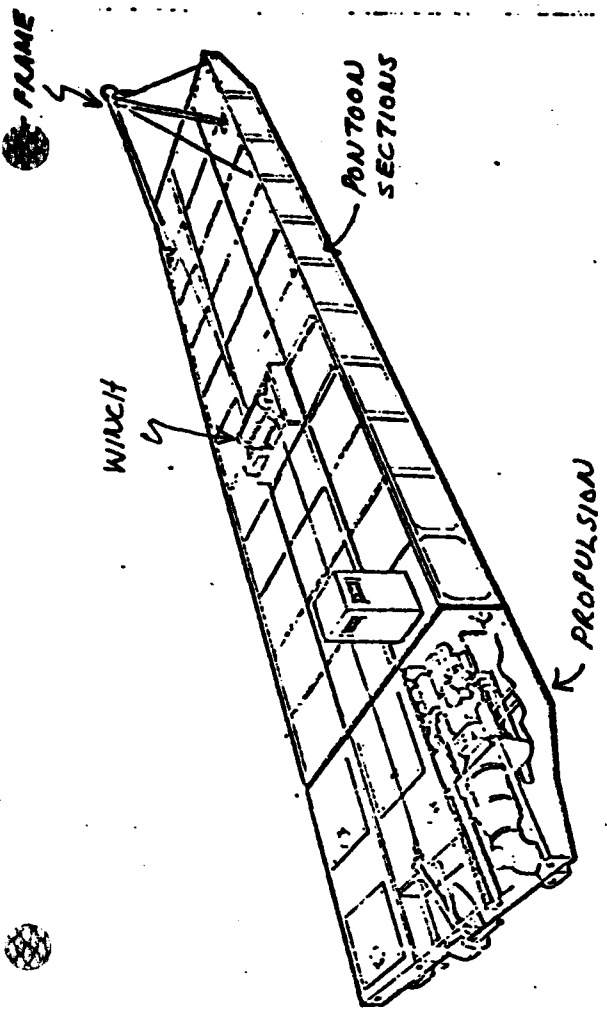
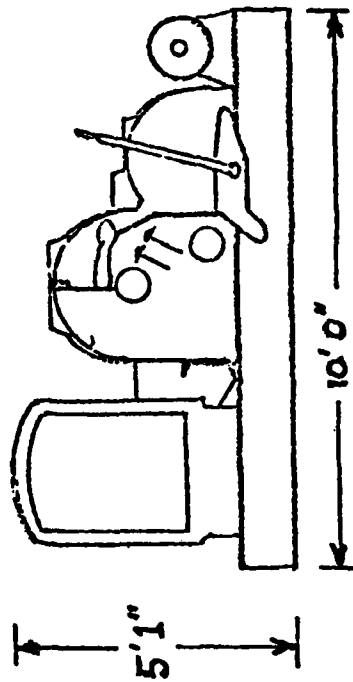
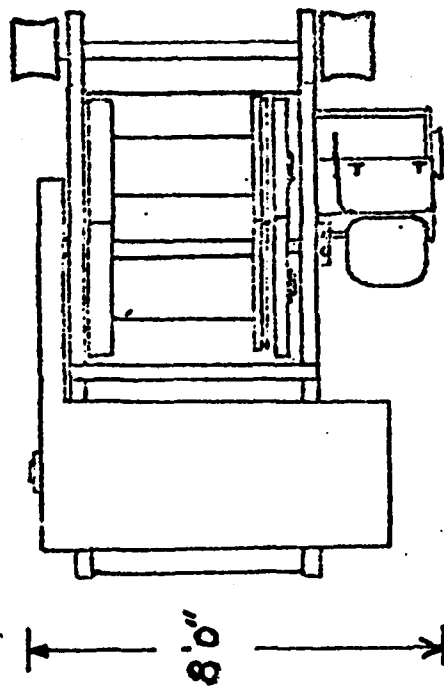

Figure 12

SKAGIT MODEL BU-18 MARINE WINCH



DRUM SIZE . . . . .	30"x13"
CABLE CAPACITY . . . . .	940' OF 7/8" CABLE
BRAKES . . . . .	FOOT-OPERATED, DRUM TYPE
CLUTCH . . . . .	HAND-OPERATED
WEIGHT . . . . .	8,500 POUNDS
ENGINE . . . . .	DETROIT DIESEL 106 HP
PERFORMANCE . . . . .	FULL DRUM: 15,700 LB @ 83 FPM
	AVG. DRUM: 21,200 LB @ 61 FPM
	BARE DRUM: 32,900 LB @ 39 FPM

Figure 13

	<u>Completion Date</u>
o Complete construction of SPC/SLWT hull	Feb 77
o Convert SPC to SLWT	Nov 77
o Test and evaluation of SLWT	Mar 78

### 3.5 RO/RO (Roll on/Roll off)

This presentation was made by Dick Seabold (CEL, Av 360-4864). RO/RO refers to vehicles (containing cargo) that can be driven on and off ships. The vehicle drives down a ramp onto a beached floating platform and then onto the beach. Ships which have a RO/RO capability are referred to as RO/RO ships. There are three RO/RO concepts: side port (figure 14), quarter ramp (figure 15), and stern port (figure 16).

### 3.6 Temporary Container Discharge Facility (TCDF)

#### 3.6.1 Overview

This presentation was given by Cliff Stevens (NSRDC, Av 281-2261). This rationale for the TCDF development is:

- o Contingency container off-load capability
- o Utilize MSC or commercial ships/Army DeLong barges
- o Reduced peacetime ownership costs

The TCDF development approach is shown in the flow diagram of figure 17. The development tasks to be accomplished in the TCDF program are:

- o Crane survey
- o Platform survey (ship/barge)
- o Derate/modify cranes
- o T&E cranes/validate derating
- o Develop pendulation control bridle
- o Develop crane foundation

The TCDF development milestones are shown in figure 18.

The TCDF platform assessment tasks are:

- o Survey ship candidates

SIDE PORT CONCEPT

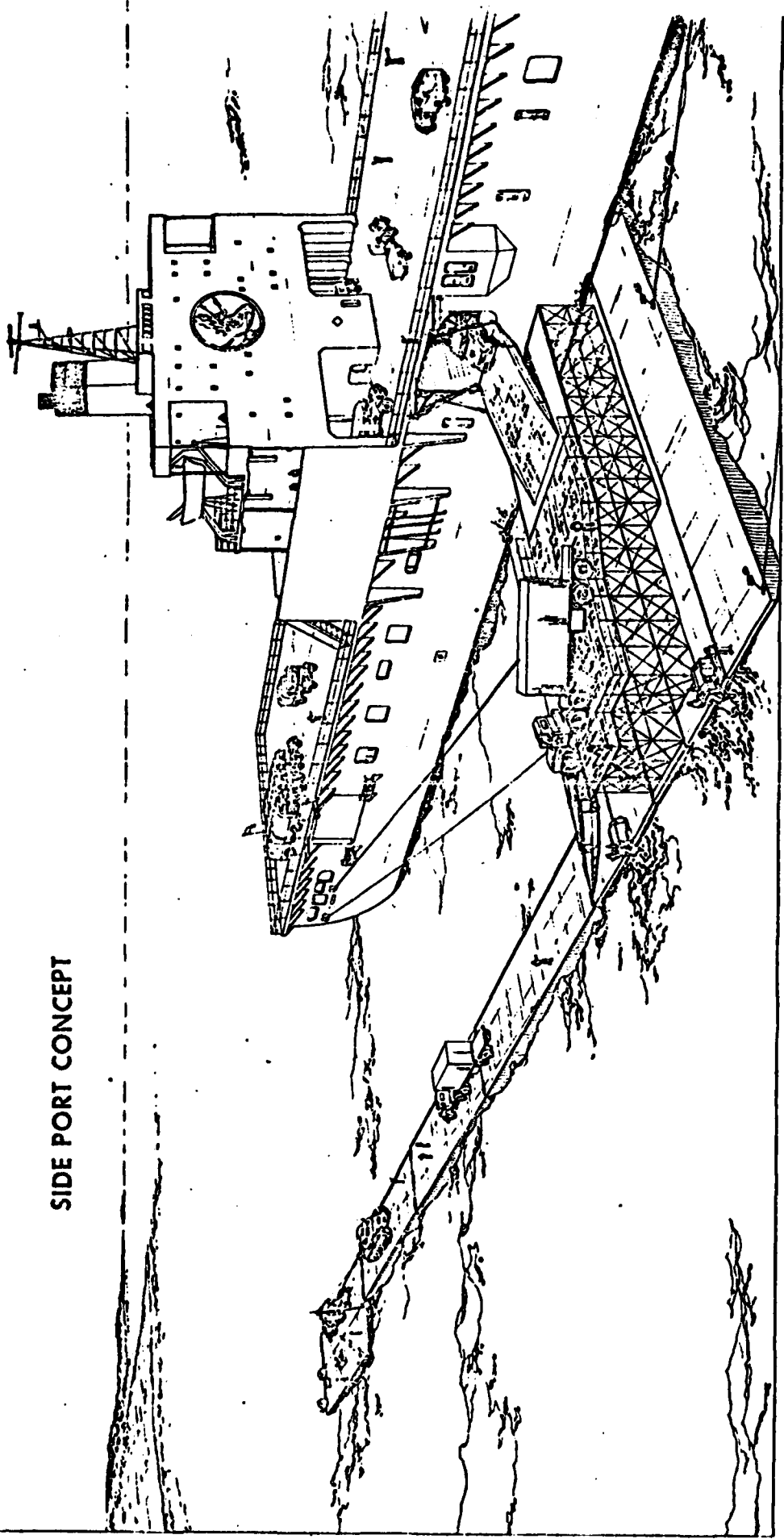

Figure 14

QUARTER RAMP CONCEPT

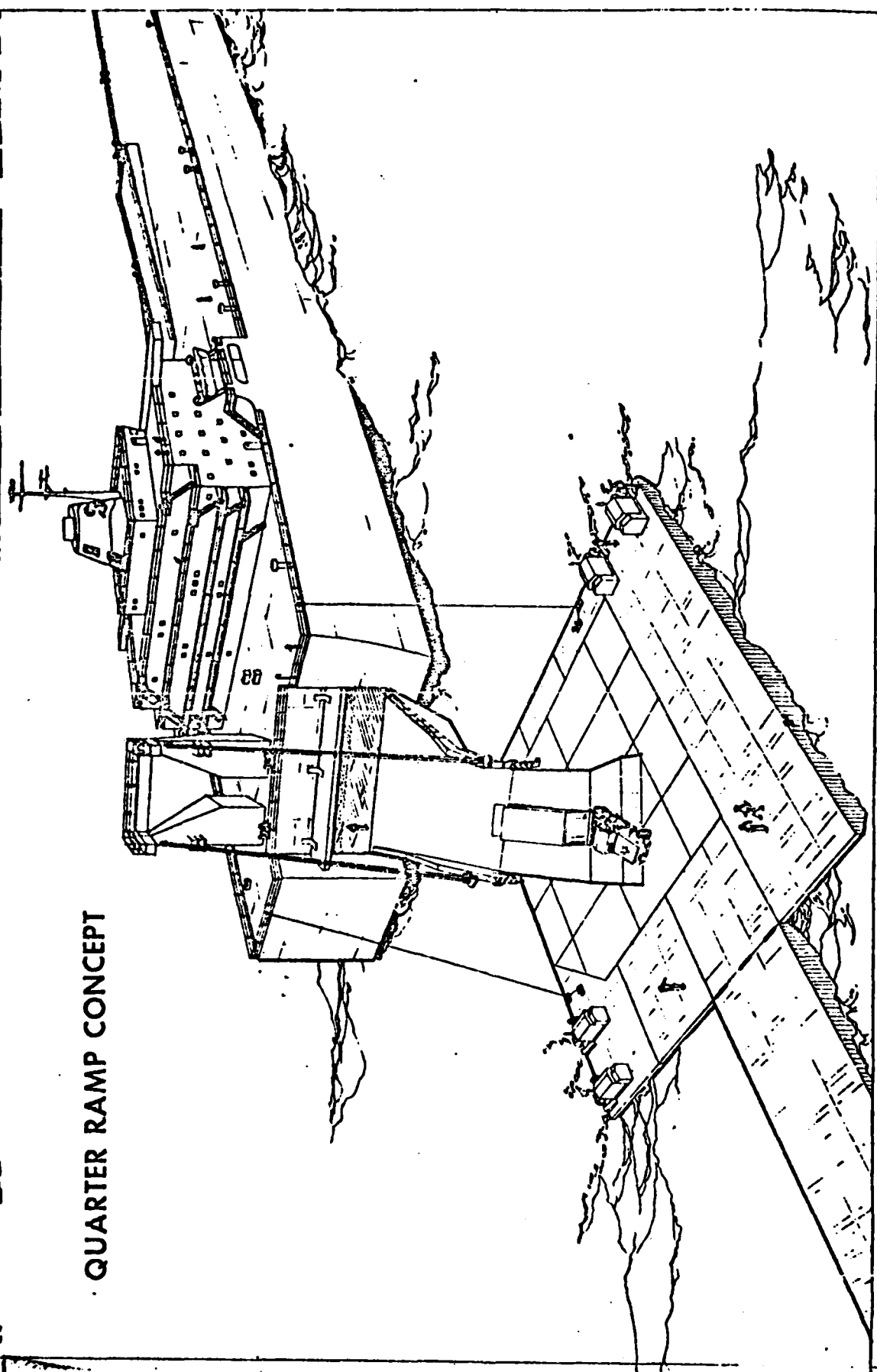

Figure 15

STERN PORT CONCEPT

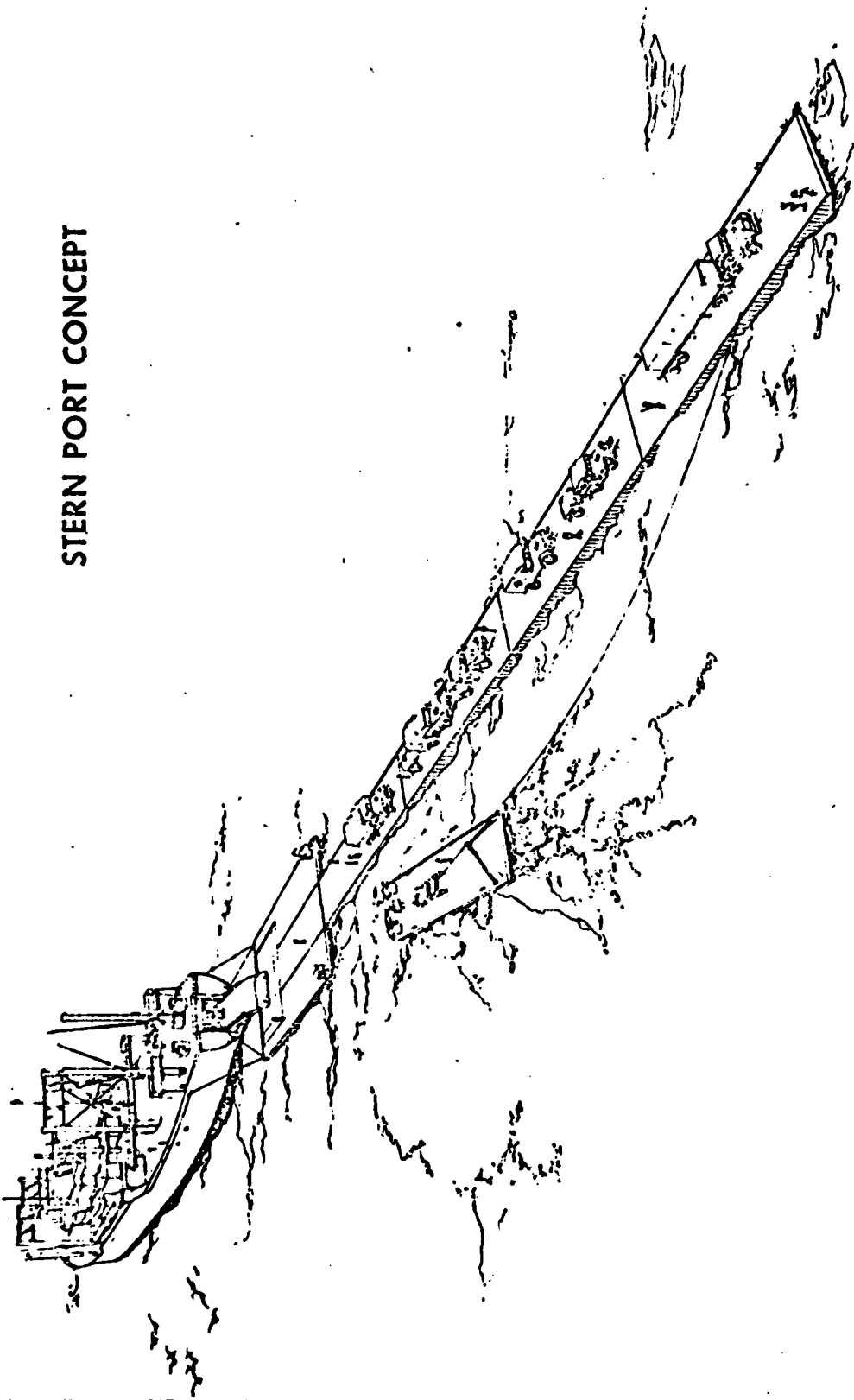
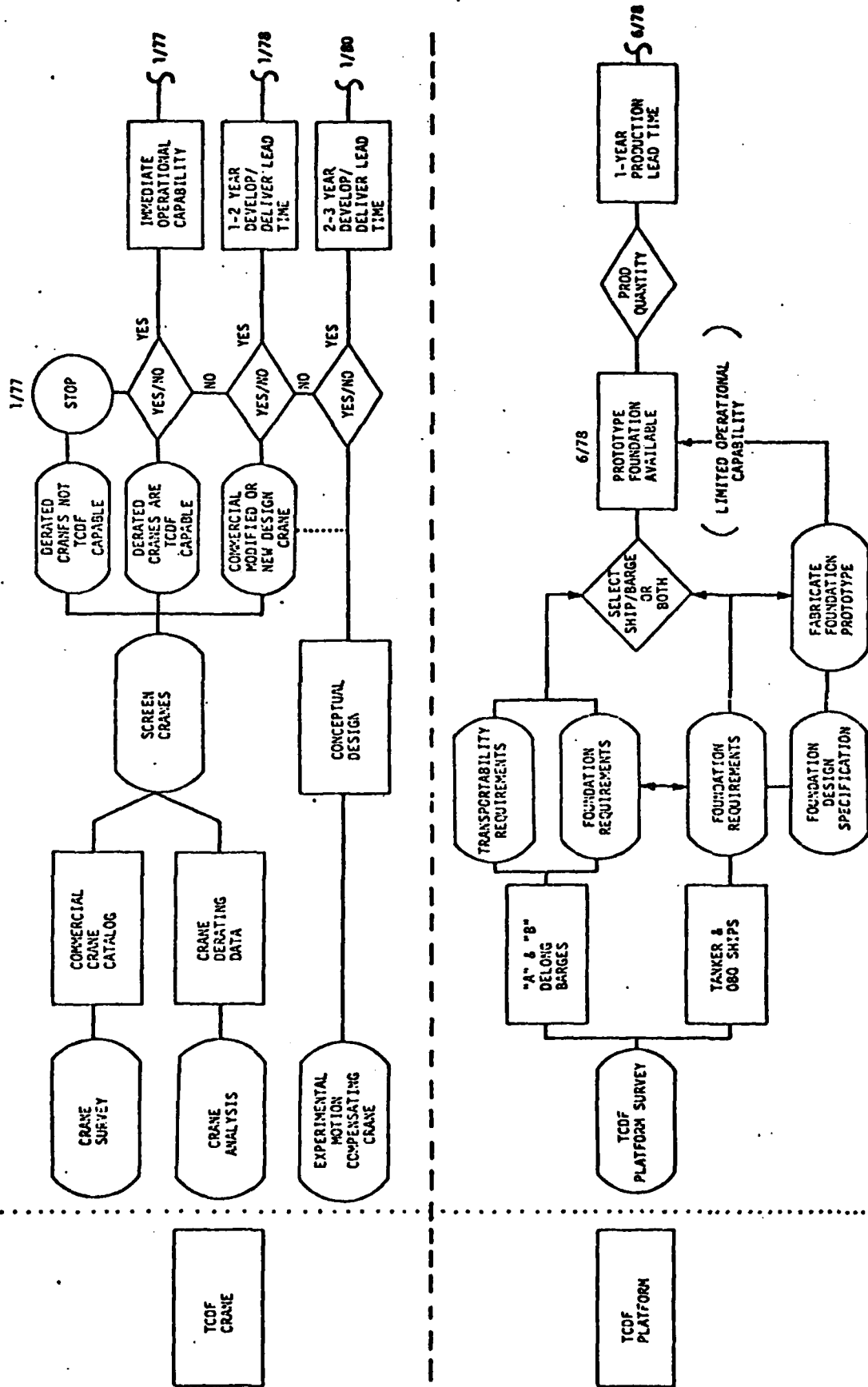

Figure 16

# TCDF DEVELOPMENT APPROACH



(FLOW SEQUENCE NOT TIME SCALED)

Figure 17

TCDF DEVELOPMENT MILESTONES

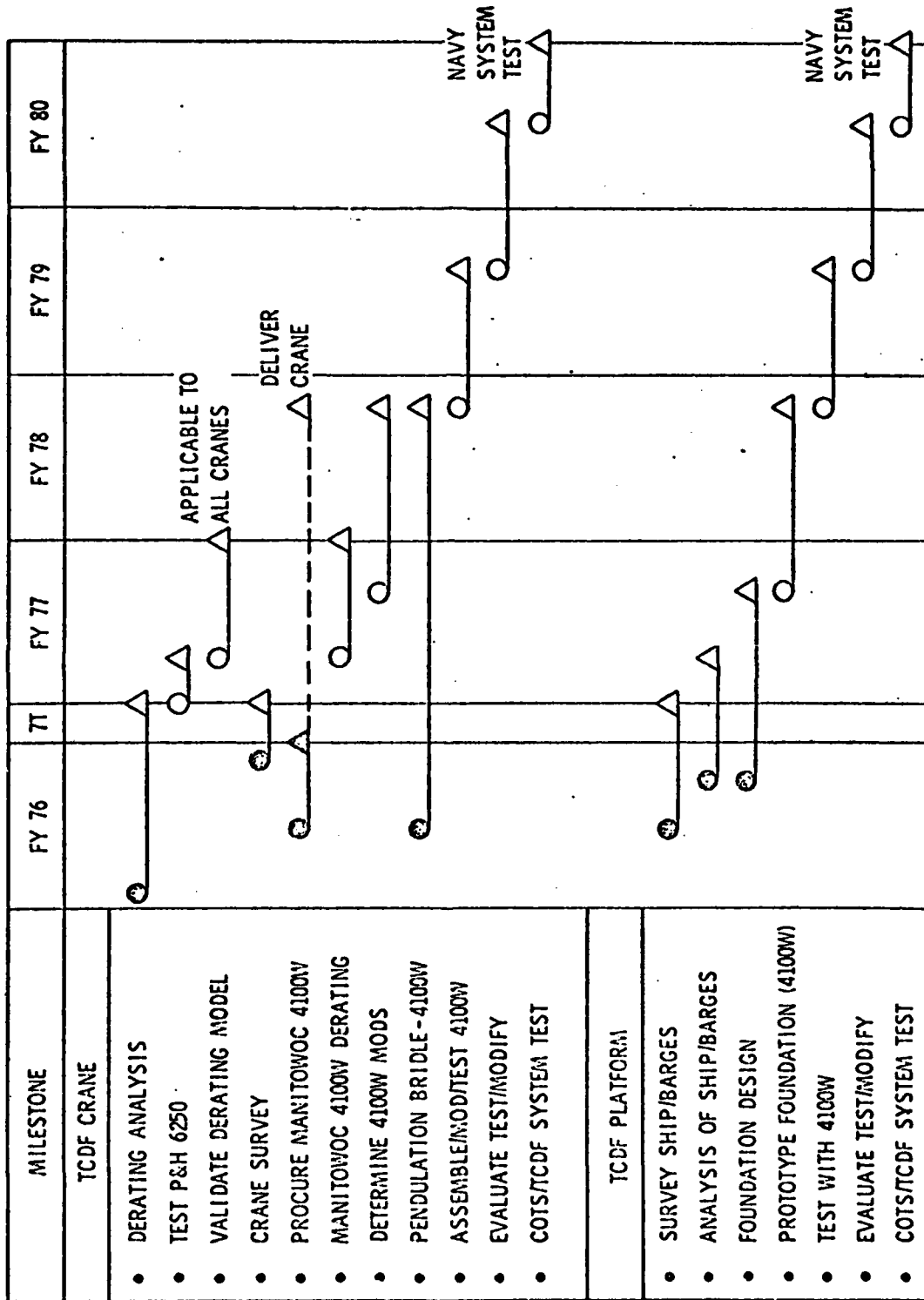

Figure 18

- o Structural and stability analysis
- o Crane foundation design
- o Fabricate 4100W TCDF crane foundation
- o T&E foundation

The TCDF platform development milestones are shown in figure 19.

### 3.6.2 Crane Machinery Analysis

This presentation was given by Phil Stone (CEL, Av 360-4207).

- |           |   |
|-----------|---|
| OBJECTIVE | - Develop systematic procedures to assess safety and reliability of land cranes operating in a marine environment.  |
| APPROACH  | - Analyze candidate cranes<br>P&H 6250 TC (Detailed)<br>Manitowoc 4100W (Detailed)<br>American 1100 (Baseline comparative)  |
| PROGRESS  | - Analysis of P&H 6250 TC crane - 60% complete<br>- Analysis of Manitowoc 4100W crane - 20% complete  |
| PLANS     | - Conference with P&H to discuss findings (Aug 76)<br>- Conference with Manitowoc to discuss findings (Aug 76)<br>- Tests with Army P&H 6250 TC crane (Aug 76-Nov 76)                               |
| RESULTS   | - By September 1976 -<br>Complete failure mode analysis of P&H 6250 TC<br>Complete failure mode analysis of Manitowoc 4100W<br>Derating criteria<br>Recommendations for instrumentation and testing |

The following structural tests will be performed on the boom of the P&H 6250:

- o SAE J987 test
- o Land stiffness test
- o Dynamic land test
- o Dynamic sea test

The test results will be compared to the analytical results to verify the analytical procedures. The steps in the structural analysis are shown in figure 20.

TCDF PLATFORM DEVELOPMENT  
MILESTONES

MILESTONE	FY 76	7T	FY 77	FY 78	FY 79	FY 80
<ul style="list-style-type: none"> <li>• SURVEY PLATFORMS</li> <li>• STABILITY &amp; STRUCTURAL ANALYSIS</li> <li>• PRELIM FOUNDATION DESIGN</li> <li>• DESIGN/FABRICATE FOUND.</li> <li>• T&amp;E 4100W FOUNDATION</li> <li>• EVALUATE &amp; MODIFY</li> <li>• COTS/TCDF SYSTEM TEST</li> </ul>						

1007-26

Figure 19.

# STRUCTURAL ANALYSIS

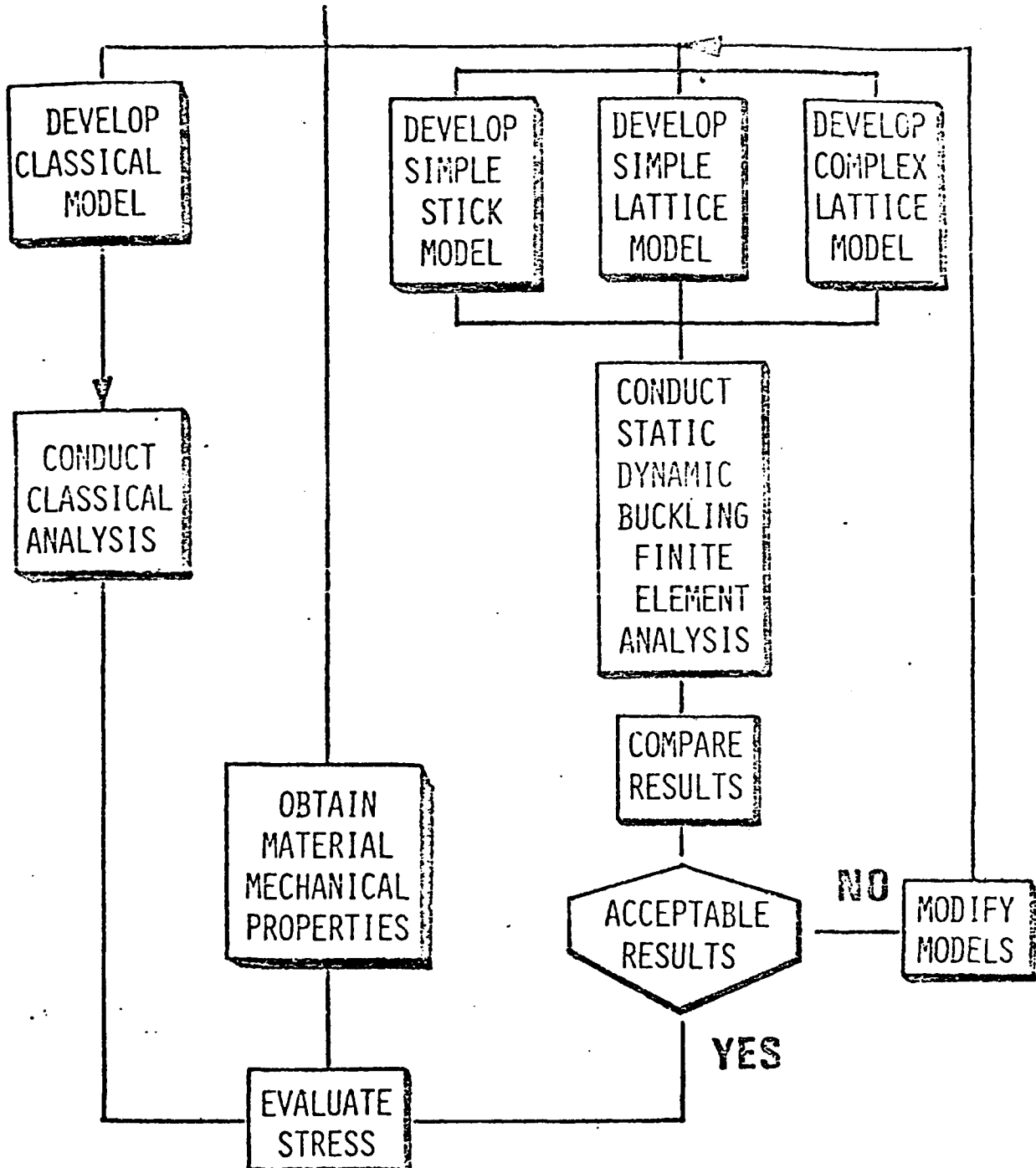

STRENGTH

Figure 20

10000

The milestones in the crane boom analysis are:

- o Complete TM describing classifical results
- o Complete TM describing platform drop out load
- o Jul 76 TM describing P&H 6250 derating curves
- o Aug 76 TM describing land and sea tests
- o Dec 77 TM describing test results - P&H 6250

It is recommended that FPO-1 receive copies of these reports.

### 3.6.3 Crane Boom Analysis: T&E of the P&H 6250

This presentation was given by Skip Johnson (CEL, Av 360-5742). The objective of the analysis is to develop an analytical procedure for determining crane performance limits when operating from a floating platform moored in the open sea. The approach to achieving the objective is shown in figure 21. The anticipated loads on the boom are:

1. DEAD LOAD
2. LIVE LOAD
  - o In plane
  - o Out of plane
  - o Hoist line component
  - o Fleet angle
  - o Off lead
3. WIND
  - o Pressure on boom
  - o Pressure on load
4. DYNAMIC
  - o Platform drop out
  - o Rebound
  - o Colliding objects
  - o Luffing
  - o Swing
  - o Hoisting
  - o Pendulation
  - o Restrained pendulation (Tag Line)
  - o Base motion

### 3.6.4 Crane Survey; Human Factors Aspects; Power Tagline

This presentation was given by Mr. J. Traffalis (CEL, Av 360-5791). The objective of the crane availability survey is to compile a catalog of commercially available cranes in CONUS for use with the TCDF for off-loading containerships. The approach to achieving the objective is:

1. CRANE SURVEY
  - Crane manufacturers
  - Crane owners
  - Crane agencies (sales)
2. COMPILE CATALOG
  - o Crane data
    - General

ANALYSIS IS INCLUDED BUT PREVIOUSLY DISC  
APPROACH

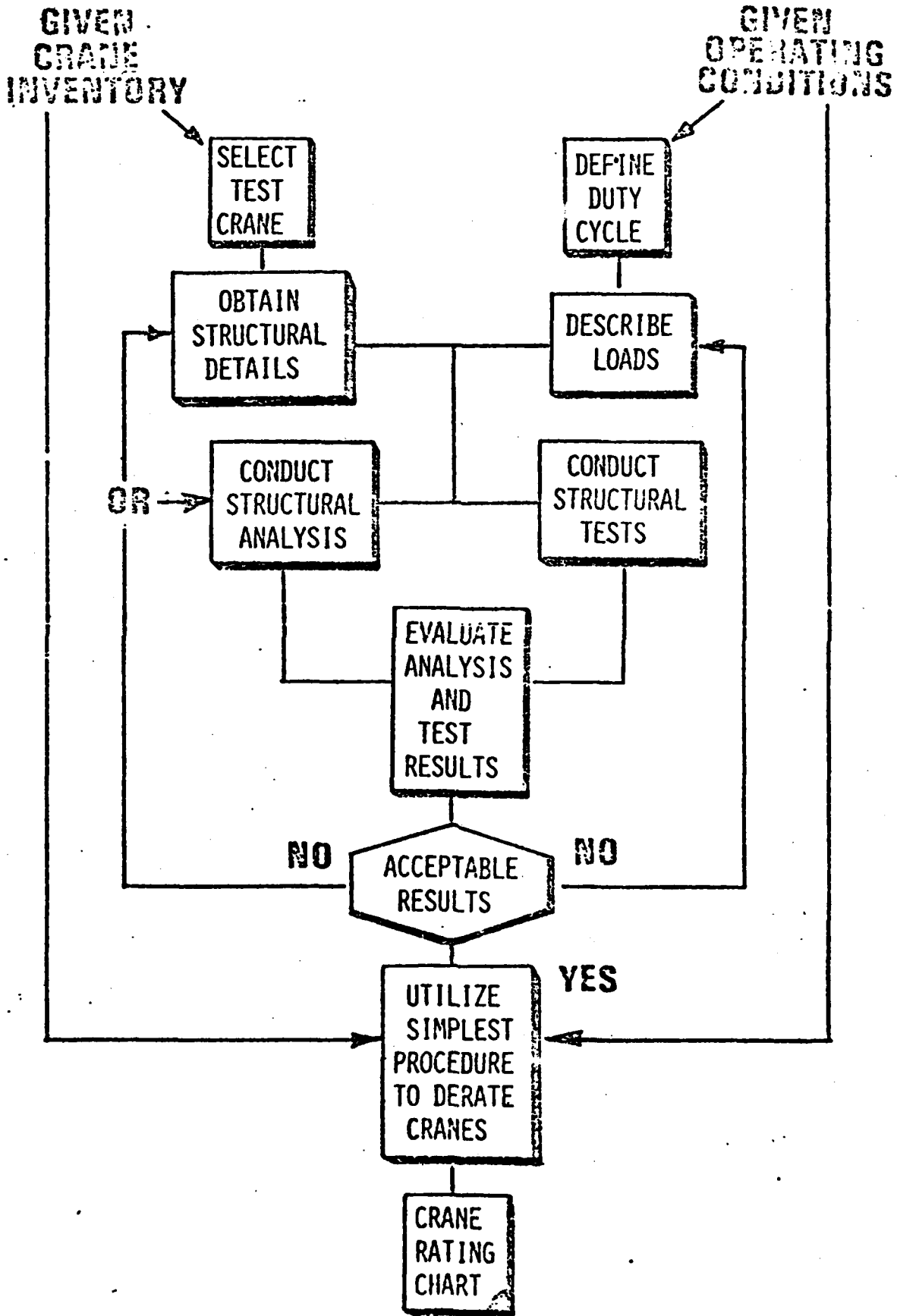

Figure 21

Manufacturer  
Type  
Model/rating

- Performance
  - Boom
  - Dimensions and weight
  - Mobilization time
- Owner data
  - Location
  - Mission
  - Criticality
  - Cranes available

The crane availability survey is 30% complete. The intended completion date for the survey is November 1976.

The objective of the human factors study is to develop a Navy enlisted code for COTS crane operators. The approach to achieving the objective is to conduct a study to define a Navy enlisted personnel profile for a COTS crane operator. Once the skill and training requirements are defined, the billet will be worked into the Navy system. The task is scheduled for completion in June 1976.

The objective of the power tagline system is to develop a means for the control of load pendulation when off-loading containers at sea. The approach to achieving the objective is to simply develop a powered tagline system. A prototype unit has been designed and fabricated. The prototype will be installed on a P&H 6250 crane and operationally tested on land and at sea. The testing is scheduled to be in October 1976.

### 3.6.5 Anti-Pendulation Bridle

This presentation was made by Frank Stora (MERADCOM, Ft Belvoir, Av 354-5802). The anti-pendulation bridle lowers the point from which a load can swing from the top of the crane boom to a point that is approximately the height of the crane cab. Figure 22 shows a crane without the anti-pendulation bridle. Figure 23 shows the same crane with the anti-pendulation bridle installed.

A movie was shown which simulated loading an 8' x 8' x 20' container on an LCM-6. At first, the crane was configured without the anti-pendulation bridle. The crane never loaded the container aboard the LCM-6. The anti-pendulation bridle was then installed on the crane and demonstrated a dramatic load control handling capability.

This project was only about a month old at the time of the presentation. The major development milestones are shown in figure 24.

### 3.6.6 Test and Evaluation of 4100W

This presentation was made by Mr. J. Traffalis (CEL, Av 360-5791). The expression "4100W" refers to the Manitowoc 4100W crane. The objective

BASIC CRANE CONFIGURATION

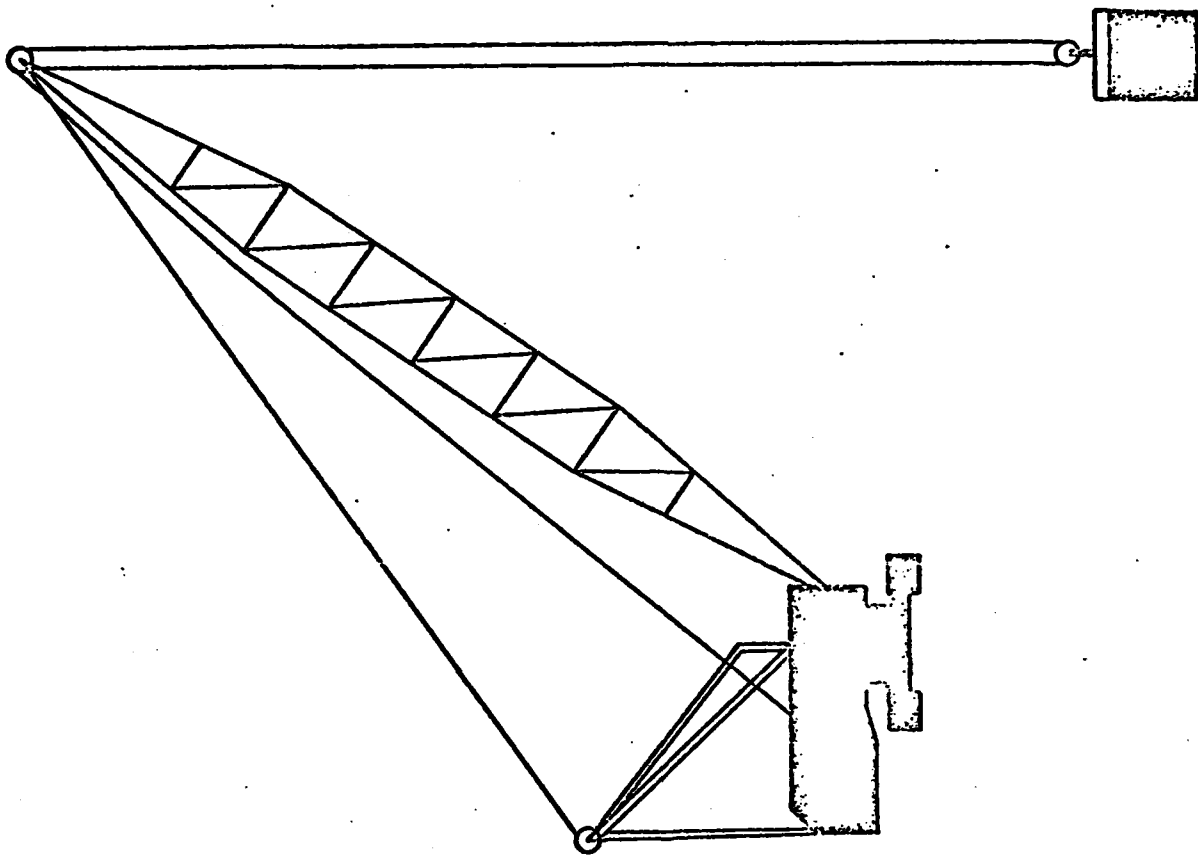

Figure 22

PENDULATION CONTROL BRIDLE

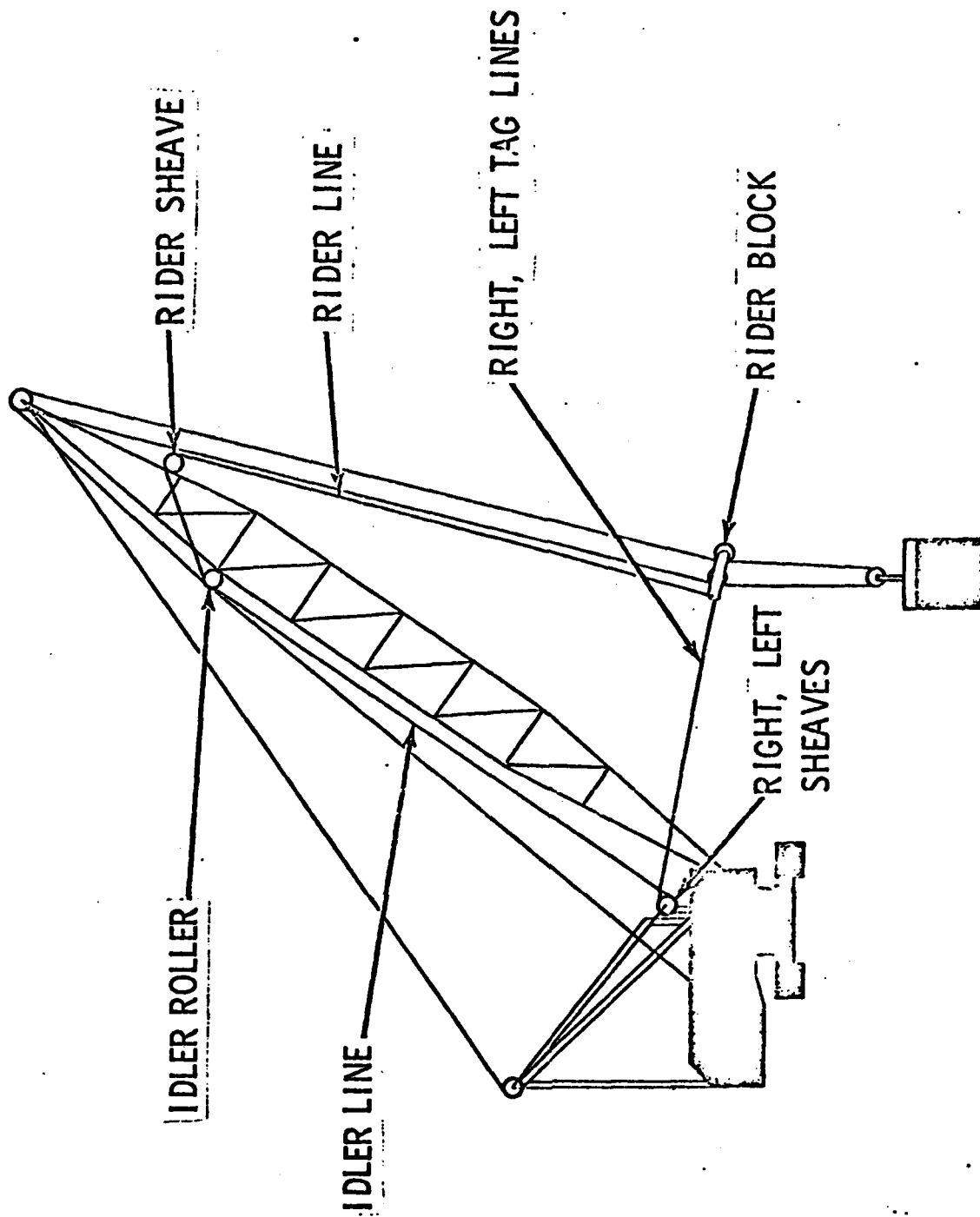

Figure 23

**PENDULATION CONTROL BRIDLE  
DEVELOPMENT MILESTONES**

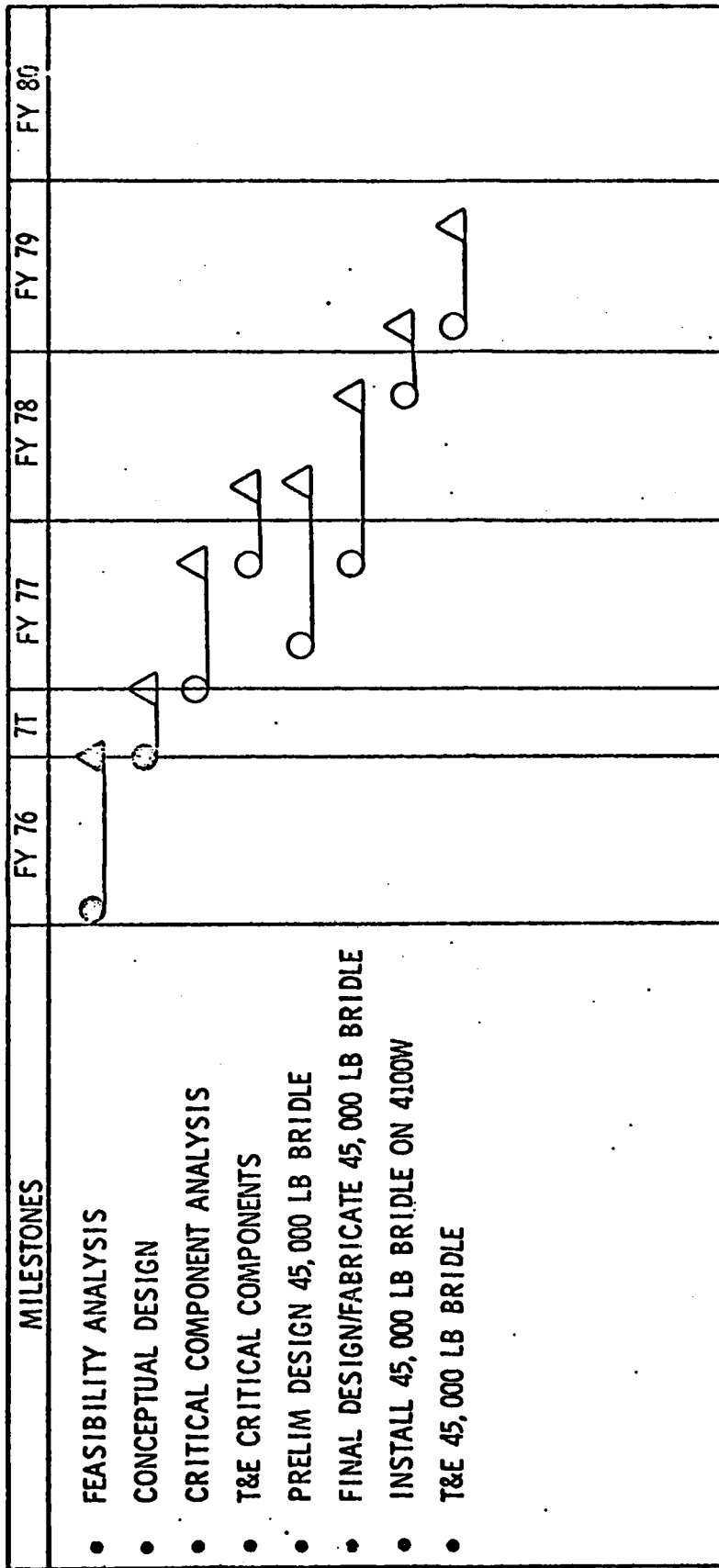

Figure 24

1072-26

is to provide a "test bed" for integrated TCDF operations. The approach to achieving the objective is to procure a crane which satisfied both TCDF and COD lift/reach requirements. The Manitowoc 4100W crane with extended capability option (ringer) meets these requirements. The Manitowoc 4100W crane development milestones are shown in figure 25.

### 3.6.7 Tethered Float Breakwater (TFB)

This presentation was given by Bob Taylor (CEL, Av 360-5419) although the project is assigned to Mr. J. B. Berkley (NUC, (714) 225-6293). The objective is to provide a transportable, open ocean wave protection system. The project is partially funded by the State of California which has an interest in protecting marinas along the California Coast. CEL is involved as:

- o Navy member of TFB Advisory Board
- o Engineering consultant
  - o Moorings
  - o Concrete
  - o Corrosion
  - o Bio-fouling
- o Address problems unique to Navy needs
  - o Data sufficiency for Navy use environments
  - o Configurations and applications for Navy
  - o Transportable breakwater design

The TFB has the following applications:

- o Offloading of cargo ships
- o Harbors of refuge and secondary ports
- o Offshore dredging
- o Offshore construction
- o Oil-spill containment

The TFB has the following characteristics:

- o Transportable: for installation at remote sites
- o Relocatable: for temporary installations
- o Practicable: in deep water and shallow
- o Unaffected: by water level changes, including tides
- o No harmful environmental impact

## 4.0 RECOMMENDATIONS

A significant crane analysis capability is being developed as

# MANITOWOC 4100W CRANE DEVELOPMENT MILESTONES

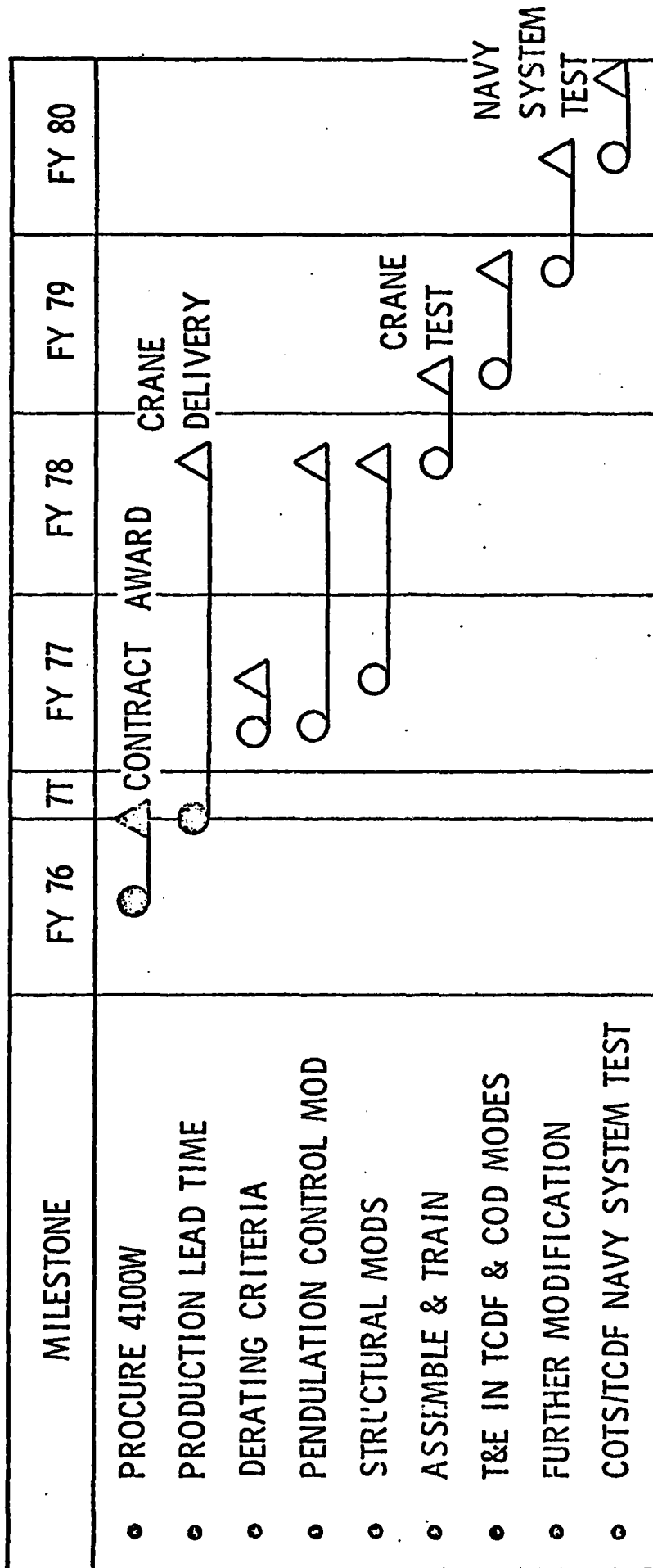

1869-76

Figure 25

part of the COTS program. It is recommended that FPO-1 monitor this developing capability particularly in the areas of crane machinery and crane boom analysis.

The LOTS tests are scheduled for 1977 at Ft. Story, VA. It is possible, especially with the SEACON, that FPO-1 could make a contribution to this effort.

TIMOTHY F. SULLIVAN

AMPHIBIOUS/ADVANCED BASE PROGRAM BRIEFING

Monday Afternoon-12 July      Confidential Briefing of Joint Navy/MarCorps POL Program

1400 - 1445	POL Overview and "NOW" Capability	Hollan
1445 - 1500	SPM Fuel Buoy	Conti
1500 - 1515	Hoses and Pipelines	Clark
1515 - 1600	POL Storage	Albertson
1600 - 1615	Propellant Anchors for SPM Fuel Buoy	True
1615 - ----	DISCUSSION	

Tuesday - 13 July      Unclassified

0830 - 0900	Amphibious Logistic Support Ashore	Lambiotte
0900 - 0920	Dozer Blade Control Kit. (Movie)	Ward
0920 - 0940	Soils Tech & Surfacing	White
0940 - 1000	PALCON	Seabold
1000 - 1020	BREAK	
1020 - 1040	Cargo Transfer	Wolfe
1040 - 1110	LASH/SEABEE Lift of USMC Equipment	Davis
1110 - 1125	Expeditionary Hangar	Seabold
1125 - 1140	TACOSS XI & XII	Seabold
1140 - 1330	LUNCH	
1330 - 1400	Remote Control Firefighting Module & Berm	Bayles
1400 - 1420	Expeditionary Site Sanitation	Chan/Kuepper
1420 - ----	DISCUSSION/TOUR	

COTS PROGRAM BRIEFING - 14 July 1976

0815 - 1130\* - Elevated Causeway

- (a) Overview . . . . . R. Towne
- (b) Lift System/Spudwells . . . . . C. Skaalen
- (c) Side Connectors/Structural Aspects . . . . . B. Karrh
- (d) End Connectors . . . . . H. Conti
- (e) Fendering . . . . . D. Davis
- (f) DDR&E LOTS Tests . . . . . R. Towne

1130 - 1150 - Powered Causeway . . . . . S. Wang

1150 - 1245 - "No Host" Luncheon - Front Lawn

1245 - 1310 - Side-Loadable Warping Tug . . . . . B. Karrh

1310 - 1330 - RO/RO . . . . . R. Seabold

1330 - 1630\* - TCDF

- (a) Overview of all TCDF Development Efforts; Ship Survey & Foundation Development . . . . . C. Stevens
- (b) Crane Machinery Analysis . . . . . P. Stone
- (c) Crane Boom Analysis; Test and Evaluation of P&H 6250 . . . . . F. Johnson
- (d) Crane Survey; Human Factors Aspects; Power Tagline . . . . . J. Traffalis
- (e) Anti-Pendulation Bridle . . . . . F. Stora
- (f) Test and Evaluation of 4100w . . . . . J. Traffalis
- (g) Tethered Float Breakwater . . . . . R. Taylor

---

\*Ten-minute breaks at approximately 1000 and 1400.

ATTENDEES AT AMPHIBIOUS/ADVANCED BASE BRIEFING  
7/12/76 & 7/13/76

NAME	ORGANIZATION	PHONE
LCDR. J. L. RENZETTI	PHIBCB-1	(714) 437-2527
LCDR. W.F. CLARKE	PHIBCB-1	(714) 437-2524
LCDR. W.R. MITCHUM	PHIBCB-2	8-680-7682
LCDR. W.R. RICE	NBG 2	8-680-7117
MEL HERRMAN	NAVFAC	8-221-9044
M. ESSOGLOU	NAVFAC	8-221-8535
KEN HANKERSON	NAVFAC	8-221-8536
T. SULLIVAN	NAVFAC	8-288-3881
LCDR. E.R. DETERLE	NAVMAT	692-2144
MAJOR J. HOY	OHSD (I&L)	8-255-5407
D. DANNER	MCDEC	278-2686
LT. COL. J. STRICKLAND	HQMC	255-3006
Other CEL Personnel		

ATTENDEES AT CEL/COTS BRIEFING 7/14/76

Name	Organization	Phone
LCDR. J.L. RENZETTI	PHIBCB-1	(714) 437-2527
LCDR. W.F. CLARKE	PHIBCB-1	(714) 437-2524
LCDR. W.R. MITCHUM	PHIBCB-2	8-680-7682
LCDR. W.R. RICE	NBG 2	8-680-7117
MEL HERRMAN	NAVFAC	8-221-9044
M. ESSOGLOU	NAVFAC	8-221-8535
KEN HANKERSON	NAVFAC	8-221-8536
T. SULLIVAN	NAVFAC	8-288-3881
J.B. BERKLEY	NUC	(714) 225-6293
R.L. WATTS	NUC	(714) 225-6291
D. DAVIS	CEL	8-360-4217
J. TRAFFALIS	CEL	8-360-5791
W. SHAW	CEL	8-360-5407
B. KARRH	CEL	8-360-4865
H. CONTI	CEL	8-360-5592
A. RAUSH	CEL	8-360-5154
K. TOWNE	CEL	8-360-5416
E. LEICHTMAN	CESO	8-360-4360
F. STORA	MERADCOM	8-354-5802
P. B DAHL	EG&G	(301) 948-4350
W. WESSEL	SEA INC	485-0452
L. BENNEN	NAVSEA	(202) 695-1306

ATTENDEES AT CEL/COTS BRIEFING 7/14/76 (Con't)

Name	Organization	Phone
LCDR. E.R. DETERLE	NAVMAT	692-2144
MAJOR J. HOY	OHSD (I&L)	8-225-5407
D. DANNER	MCDEC	278-2686
LT. COL J. STRICKLAND	HQMC	225-3006
S.R. PETOLA	NWHC	8-440-7502
R.F. BAILEY	NSCL	8-436-4180
W.D. CULPEPPER	NSCL	8-436-4198
C.C. STEVENS	NSRDC	8-281-2261

END

FILMED

3 - 86

DTIC