

MICROCOPY RESOLUTION TEST CHART
NATIONAL BUREAU OF STANDARDS 1963-A

AD-A163 867

AN ULTRAVIOLET LASER SHADOWGRAPHY SYSTEM FOR THE SHIVA-STAR FAST CAPACITOR BANK

1st Lt Carl L. Enloe

November 1985

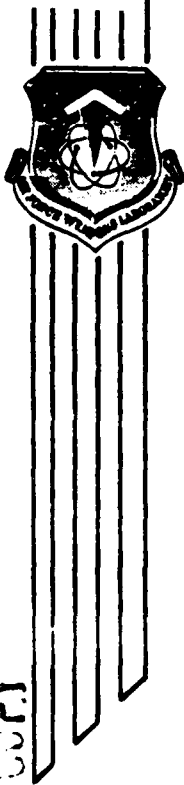

Final Report

DTIC
SELECTE
FEB 10 1986
S D D

Approved for public release; distribution unlimited.

AIR FORCE WEAPONS LABORATORY
Air Force Systems Command
Kirtland Air Force Base, NM 87117-6008

COPY

This final report was prepared by the Air Force Weapons Laboratory, Kirtland Air Force Base, New Mexico under Job Order 88091721. Lt Carl L. Enloe (AWPP) was the Laboratory Project Officer-in-Charge.

When Government drawings, specifications, or other data are used for any purpose other than in connection with a definitely Government-related procurement, the United States Government incurs no responsibility or any obligation whatsoever. The fact that the Government may have formulated or in any way supplied the said drawings, specifications, or other data, is not to be regarded by implication, or otherwise in any manner construed, as licensing the holder, or any other person or corporation; or as conveying any rights or permission to manufacture, use, or sell any patented invention that may in any way be related thereto.

This report has been authored by an employee of the United States Government. Accordingly, the United States Government retains a nonexclusive, royalty-free license to publish or otherwise reproduce the material contained herein, or allow others to do so, for United States Government purposes.

This report has been reviewed by the Public Affairs Office and is releasable to the National Technical Information Service (NTIS). At NTIS, it will be available to the general public, including foreign nations.

If your address has changed, if you wish to be removed from our mailing list, or if your organization no longer employs the addressee, please notify AFWL/AWPP, Kirtland AFB, NM 87117-6008 to help us maintain a current mailing list.

This technical report has been reviewed and is approved for publication.

Carl L. Enloe

CARL L. ENLOE
1st Lieutenant, USAF
Project Officer

FOR THE COMMANDER

William F. McCullough

WILLIAM F. MCCULLOUGH
Major, USAF
Chief, Plasma Physics Branch

William L. Baker

WILLIAM L. BAKER
GM-15
Chief, Advanced Technology Division

DO NOT RETURN COPIES OF THIS REPORT UNLESS CONTRACTUAL OBLIGATIONS OR NOTICE ON A SPECIFIC DOCUMENT REQUIRES THAT IT BE RETURNED.

UNCLASSIFIED

SECURITY CLASSIFICATION OF THIS PAGE

AD-A163867

REPORT DOCUMENTATION PAGE

1a. REPORT SECURITY CLASSIFICATION UNCLASSIFIED		1b. RESTRICTIVE MARKINGS	
2a. SECURITY CLASSIFICATION AUTHORITY		3. DISTRIBUTION/AVAILABILITY OF REPORT Approved for public release; distribution unlimited.	
2b. DECLASSIFICATION/DOWNGRADING SCHEDULE		5. MONITORING ORGANIZATION REPORT NUMBER(S)	
4. PERFORMING ORGANIZATION REPORT NUMBER(S) AFWL-TR-85-82		7a. NAME OF MONITORING ORGANIZATION	
6a. NAME OF PERFORMING ORGANIZATION Air Force Weapons Laboratory	6b. OFFICE SYMBOL (If applicable) AWPP	7b. ADDRESS (City, State and ZIP Code)	
6c. ADDRESS (City, State and ZIP Code) Kirtland Air Force Base, NM 87117-6008		9. PROCUREMENT INSTRUMENT IDENTIFICATION NUMBER	
8a. NAME OF FUNDING/SPONSORING ORGANIZATION	8b. OFFICE SYMBOL (If applicable)	10. SOURCE OF FUNDING NOS.	
8c. ADDRESS (City, State and ZIP Code)		PROGRAM ELEMENT NO. 62601F	PROJECT NO. 8809
		TASK NO. 17	WORK UNIT NO. 21
11. TITLE (Include Security Classification) AN ULTRAVIOLET LASER SHADOWGRAPHY SYSTEM FOR THE SHIVA-STAR FAST CAPACITOR BANK			
12. PERSONAL AUTHOR(S) Enloe, Carl, 1st Lt			
13a. TYPE OF REPORT Final	13b. TIME COVERED FROM 5 Nov 84 TO 30 Jun 85	14. DATE OF REPORT (Yr., Mo., Day) 1985 November	15. PAGE COUNT 24
16. SUPPLEMENTARY NOTATION			
17. COSATI CODES		18. SUBJECT TERMS (Continue on reverse if necessary and identify by block number)	
FIELD	GROUP	SUB. GR.	
			Laser shadowgraphy Plasma diagnostics
			Nitrogen lasers Ultraviolet lasers
19. ABSTRACT (Continue on reverse if necessary and identify by block number) An ultraviolet laser shadowgraphy system has been developed which is sensitive to plasma densities in the few 10^{16} cm^{-3} regime. It is fast enough (<10 ns exposure time) to freeze the motion of even fast-moving plasmas, and it is capable of operating in an environment where there is a high level of both background light and electrical noise. System setup and adjustments as well as interpretation of data from a coaxial-geometry experiment are discussed.			
20. DISTRIBUTION/AVAILABILITY OF ABSTRACT UNCLASSIFIED/UNLIMITED <input checked="" type="checkbox"/> SAME AS RPT <input type="checkbox"/> DTIC USERS <input type="checkbox"/>		21. ABSTRACT SECURITY CLASSIFICATION UNCLASSIFIED	
22a. NAME OF RESPONSIBLE INDIVIDUAL Lt David J. Hall		22b. TELEPHONE NUMBER (Include Area Code) (505) 844-1851	22c. OFFICE SYMBOL AWPP

CONTENTS

INTRODUCTION	1
PRINCIPLES OF LASER OPERATION	2
NOISE ISOLATION	6
DOWNSTREAM OPTICS	7
SYSTEM ADJUSTMENTS	9
SIGNAL-TO-NOISE RATIO	11
INTERPRETING DATA	13
CONCLUSION	17
REFERENCES	18



Accession For	
NTIS CRA&I	<input checked="" type="checkbox"/>
DTIC TAB	<input type="checkbox"/>
Unannounced	<input type="checkbox"/>
Justification	
By _____	
Distribution /	
Availability Codes	
Dist	Special
A-1	

FIGURES

<u>Figure</u>		<u>Page</u>
1	Nitrogen laser in operation	3
2	Spark-gap switch circuit	4
3	Laser alignment procedure	5
4	Shadowgraphy system overview	8
5	Pinhole alignment procedure	10
6	Laser- and background-light ray tracing diagram	11
7	Dimensions integral from Equation 13	15

INTRODUCTION

A four-channel ultraviolet laser shadowgraphy system has been developed for use on the SHIVA-STAR capacitor bank. It is capable of exposing a shadowgraph of a 5-cm-wide cross-section of the plasma or switching region even in the presence of large background ultraviolet radiation. Exposure time is less than 10 ns. This report describes the operation of the laser shadowgraphy system.

PRINCIPLES OF LASER OPERATION

The laser shadowgraphy system uses four nitrogen lasers for illumination. These lasers are electric discharge lasers of a simple design (Ref. 1) and are pumped by a large electric current in the lasing chamber. The lasing transition takes place at a wavelength of 337.1 nm. The lasing chamber is an integral part of a Blumlein configuration as illustrated in Figure 1. Nitrogen gas is fed into the chamber at a moderate flow rate (≈ 500 cc/min). Both ends of the lasing chamber are open to atmosphere so that it is merely necessary to ensure that relatively pure nitrogen is the only gas in the lasing chamber. Both sides of the Blumlein are charged from a single power supply (the large 200-M Ω charging resistor gives a charging time of several seconds), but they are isolated from each other during discharge by a resistor so that when one side is discharged through a high-current switch, the charge voltage appears across the electrode gap in the lasing chamber and the gap subsequently breaks down. Lasing action occurs in the high-current region between the electrodes. In operation, the Blumlein is charged to between 15 and 20 kV. Laser light output is a strong function of energy stored in the Blumlein and hence of charge voltage. Also, a uniform current density between the electrodes is necessary for lasing; arcing or hot spots will quench lasing action. If the charge voltage is too low, dV/dt across the gap will be insufficient to initiate this uniform discharge; instead, several filaments of current are observed for charge voltages less than 10 kV. If the charge voltage exceeds 20 kV the Blumlein may break down to the case.

The high-current switch used in the Blumlein circuit is a sealed gas switch (EG&G Model GP-46B) capable of reliable triggering with jitter less than 10 ns if installed and operated properly. However, polarity of the charge voltage and the trigger voltage is critical. If the switch is used in any other configuration other than that illustrated in Figure 2, jitter will be unacceptably high (100 μ s to several milliseconds). The trigger pulse should be approximately the same voltage as the charge voltage. Aside from jitter, there is a (predictable) delay from the application of the trigger pulse to the onset of lasing. This delay is not especially sensitive to trigger voltage but varies with charge voltage to a large extent. Thus, if the charge voltage is changed, timing should be checked.

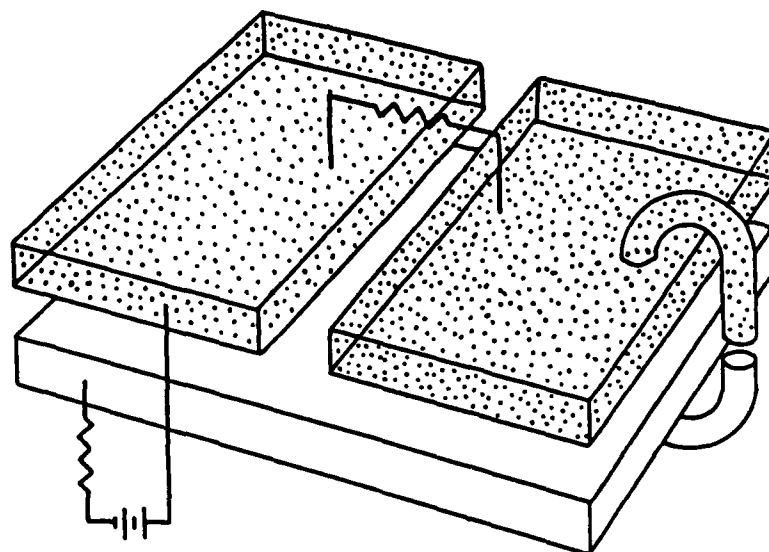

(a) Charged.

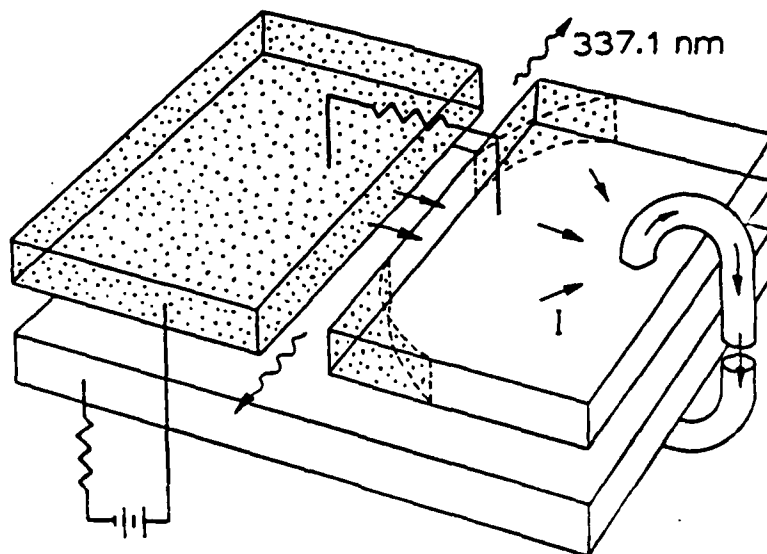

(b) During discharge (Ref. 2).

Figure 1. Nitrogen laser in operation.

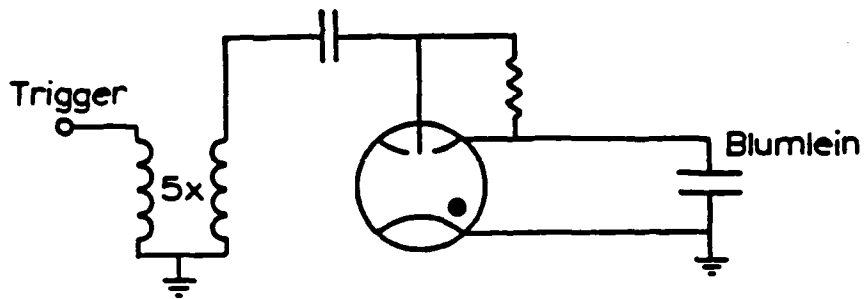
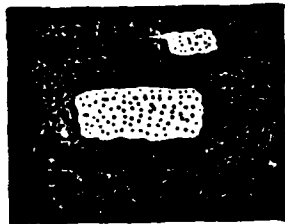
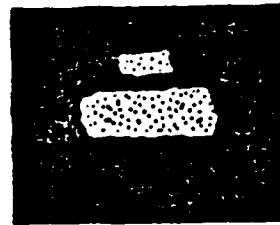

Figure 2. Spark-gap switch circuit.

The nitrogen laser radiates out both ends of the laser chamber. The laser is superradiant so that no end mirrors or resonant chamber are required to cause lasing action. However, the addition of a plane mirror at one end of the chamber significantly improves laser performance. This mirror turns the backward-going beam around, introducing some gain as it does so. The adjustment of the return mirror is a fairly delicate operation, but it is straight-forward and is performed by observing laser output on a phosphorescent screen as the mirror is adjusted. Alignment is complete when the backward-going beam returns down the center of the lasing chamber. Figure 3 illustrates a typical beam-alignment procedure.



(a) Backward-going beam high and to the right.



(b) Backward-going beam high.

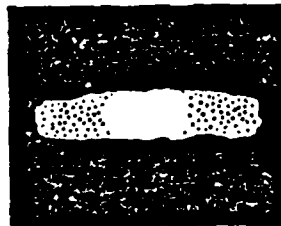

(c) Proper alignment.

Figure 3. Laser alignment procedure.

NOISE ISOLATION

Because the nitrogen lasers are electric discharge lasers, they are quite sensitive to electrical noise. To operate them successfully in the high-noise environment of the SHIVA-STAR bank, it is necessary to isolate them inside a single-walled screen room, along with all associated power supplies and trigger delay generators. Trigger signals are brought into the screen room, and photodiode signals observing laser light are returned to the instrumentation van, through fiber-optic links. Since the ground of the power supplies is allowed to float, the screen box may itself float quite high if the box is not grounded. This presents a hazard when laser alignment is taking place. Thus, the ground connection to the screen box should only be broken (the box floated) immediately prior to lights-out preceding a SHIVA-STAR shot. Holes in the box to allow the laser light to shine out apparently cause no serious reduction in the noise immunity of the system.

Laser timing is monitored by a photodiode on each laser looking at the interelectrode gap from behind the clear plastic top of the lasing chamber. Signals are terminated and added through power tees so that a single oscilloscope channel is required to monitor laser timing. The ground of the mini-coaxial cable to the photodiode will naturally float to high voltage unless grounded to the power supply of the lasers (not to the screen room). This is necessary to avoid both an excessively noisy signal and an annoying, although not terribly dangerous, shock when handling the photodiodes or fiber-optic links.

DOWNSTREAM OPTICS

The optics used to get the laser light onto film are chosen because of the peculiarities of using ultraviolet light in a high-background, high-vibration, high-debris environment. Ultraviolet light such as that produced by the nitrogen lasers is attenuated severely in crown glass and plastic. Therefore, quartz (fused silica) must be used for all transmitting optics and all reflecting optics must be first-surface. Even the small surface oxidation on the surface of an old aluminum first-surface mirror may attenuate the beam severely (half of the light or more may be lost). The natural divergence of the laser beam (0.5 deg) eliminates the need for expensive beam expanders if the lasers are moved far enough away from the plasma of interest (10 m is sufficient).

Laser light enters and exits the vacuum chamber through 0.25-in quartz plates in the 10-in diagnostic ports. A periscope arrangement has two advantages: It isolates the optics from bank vibrations, and it protects the expensive quartz lenses from debris when the quartz windows shatter. Often, the lower mirror can be dusted off (carefully) and reused shot-to-shot, while the upper mirror is destroyed.

Laser beams are focused through 75-mm-dia quartz lenses of 500-mm focal length. Ray tracing from the laser source through the lenses yields a usable field of view of 5 cm at the center of the bank. Both spatial and wavelength filtering is important for a high signal-to-noise ratio on the film. The lasers are focused through a set of 200- μ m pinholes to provide spatial filtering, while a set of bandpass filters (FWHM 2.6 nm) provide wavelength filtering. Pinholes are mounted on translation stages providing adjustment in the x-, y-, and z-axes. Bandpass filters are mounted on the film holders. Film used is Polaroid Type 55 positive-negative film. The lasers are intense enough to produce large exposures even on slow film. In interpreting data, one method of sorting laser light from background plasma light is by intensity; background light is much less intense than plasma light. An overhead, schematic view of the optical train is shown in Figure 4.

In Figure 4, two independent optical trains are shown; in actuality, four are available. According to the particular geometry of a shot, including

where one is interested in probing with shadowgraphy and what other diagnostics are being fielded, any number of channels from one to four may fit. Often, a laser beam enters on the north side of the chamber, crosses through the center near the plasma region, and is sent through an optical train on the south side of the optical table. A FORTRAN program, BEAMS, is available on the Air Force Weapons Laboratory VAX computer to trace the laser beams through the system and helps one determine the optimum placement of optical components.

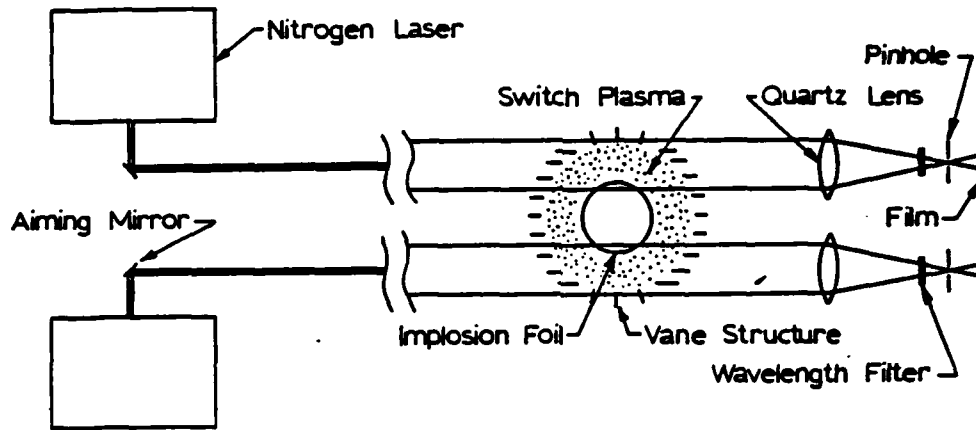

Figure 4. Shadowgraphy system overview.

SYSTEM ADJUSTMENTS

Aside from the adjustments of the lasers themselves, several other adjustments can be made to the laser shadowgraphy system. One of the most straightforward is the adjustment of illumination of the target area. Small turning mirrors used to turn the beams through approximately 45 deg before they exit the screen rooms are adjustable in two axes to finely align the beam onto the area of interest. This is readily adjusted by observing illumination on a phosphorescent screen as the beam enters and exits the vacuum chamber.

Once the (now well expanded) beam exits the vacuum chamber, it is turned through a periscope arrangement. Both the top and bottom mirrors may be adjusted vertically, although this adjustment is quite coarse. Rotation stages on both the top and bottom mirrors, however, allow one to adjust the beam accurately so that it is able to pass through the downstream optics. It is most convenient to coarsely adjust the upper mirror so that the beams fall in the center of the lower mirror (that is, so that the beams are vertical as they pass through the periscope) and to fine tune the beam path with the lower mirror alone.

By far the most critical adjustment is the position of the pinhole spatial filters. The quartz lenses in the optical train are, of course, not perfect, and the smallest spot size they will focus to is about 200 μm , the size of the filtering pinholes. Using smaller pinholes will cut off the edges of the image reducing the effective area that can be probed with the shadowgraph system. It is important that the pinhole be located at the position of the smallest spot in all three spatial coordinates. Translation stages make this adjustment possible, although it can be tedious at first. A small stick of wood with a spot of white paper glued to the end makes a good tool for finding the beam in front of the pinhole. (The laser is powerful enough to make even plain paper phosphorescent when it is focused down to a spot.) Once the pinhole position is roughly determined, observing the illumination on a phosphorescent card downstream of the pinhole makes fine adjustment possible. The z-axis adjustment (parallel to the laser beam) is made by observing the area of illumination attainable. If the pinhole is not at the z-axis position of the smallest spot, the edges of the image will be cut off. If the pinhole is grossly out of position, one will observe a diffraction pattern consisting of a bright central spot separated by a dark ring. This diffraction pattern is

also apparent when the pinhole is misaligned in the x- and y-axis. Figure 5 illustrates the adjustment procedure for the pinhole.

There is a particular aspect of alignment that may not be immediately obvious. The large metal table on which the optics are mounted can expand significantly when the temperature in the bay rises late in the afternoon. One should not expect an adjustment made the morning of the shot to be valid later in the day. Adjustment should be made up until the time of the shot, and the status of the shadowgraphy system should be monitored closely as near to the time of the shot as possible.



(a) Pinhole not at best focus.



(b) Pinhole too low.



(c) Pinhole too far left.



(d) Proper alignment.

Figure 5. Pinhole alignment procedure.

SIGNAL-TO-NOISE RATIO

The effect of the pinhole is to spatially filter out background light of the radiating SHIVA-STAR plasma, which is an intense ultraviolet radiator, from the laser signal. One may calculate the effectiveness of the noise rejection with a simple analysis. A simple model is illustrated in Figure 6. The laser light is considered as originating at infinity which is a good approximation of the actual situation. The plasma is modeled as a point source radiator at a distance x from the lens, which is also a good approximation since by the time the light passes through the periscope, the lens is approximately 3 m from the plasma. The lens has diameter a , and the diameter of the pinhole is d . The power radiated by the lens into 4π is P . Elementary optics theory tells one that the laser light is focused at a distance f , the focal length of the lens, while the plasma light focuses at a distance x' , given by

$$\frac{1}{x} + \frac{1}{x'} = \frac{1}{f} \quad (1)$$

Therefore, the plasma light falls on a defocused spot at a distance f where the pinhole was placed. This spot diameter d' is given by

$$d' = \frac{a(x' - f)}{x'} \quad (2)$$

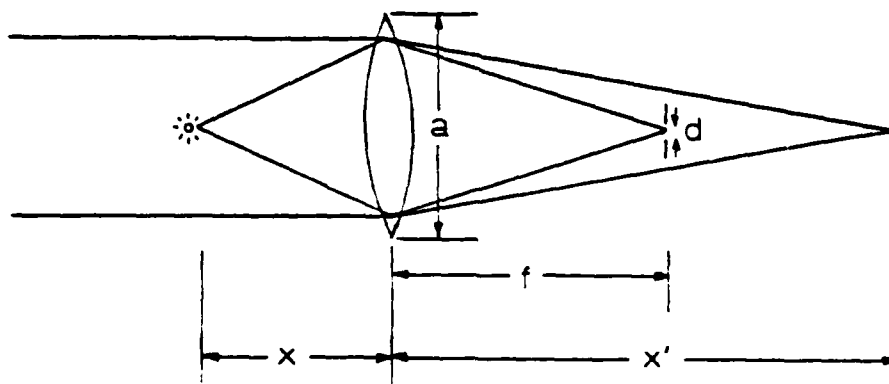

Figure 6. Laser- and background-light ray tracing diagram.

But from Equation (1),

$$\frac{(x' - f)}{x'} = \frac{f}{x} \quad (3)$$

or,

$$d' = \frac{af}{x} \quad (4)$$

Now, the power radiated by the plasma that passes through the lens, P' , is

$$P' = \frac{a^2}{16x^2} P \quad (5)$$

and the power passes through the lens that passes through the pinhole, P'' , is

$$P'' = \frac{d^2 x^2}{a^2 f^2} P' \quad (6)$$

This yields

$$P'' = \frac{d^2}{f^2} P \quad (7)$$

That is, the noise rejection capability of the spatial filter depends only on the diameter of the pinhole and the focal length of the lens, not on the lens aperture nor on the distance of the optics from the radiating plasma. This calculation was confirmed when the 250-mm focal length lenses originally in the system were exchanged for the present 500-mm focal length lenses. The signal-to-noise ratio improved by about a factor of 4 as predicted by this model.

INTERPRETING DATA

A shadowgraph is an image containing light areas (where laser light has exposed film) and dark areas (where no laser light has reached the film plane). Laser light may be prevented from reaching the film plane by two effects, attenuation and refraction. Any object in the beam line which is opaque at 337.1 nm (even objects which transmit visible light, such as clear plastics) will leave a shadow on the film plane. These shadows allow setup exposures to be made and interpreted. The shadows of vanes, cables, the foil, and other objects are easy to identify on the film. However, it is not necessary to attenuate laser light to keep it from reaching the film plane. Any light which is refracted away from the pinhole, even though it may not be severely attenuated, will not reach the film plane. Density gradients in the plasma which fills the field of view during a shot are responsible for this refraction. By introducing the pinhole as a spatial filter in the optical train, the shadowgraphy system has been made sensitive to density gradients in the same way as a schlieren system (Ref. 3).

The refractive index of a plasma is related to the electron density by the relation

$$n = 1 - \frac{\omega_{pe}^2}{2\omega^2} = 1 - \left(\frac{2\pi e^2}{\omega^2 m_e} \right) n_e \quad (8)$$

so that

$$\frac{dn}{dr} = - \left(\frac{2\pi e^2}{\omega^2 m_e} \right) \frac{dn_e}{dr} \quad (9)$$

where ω is the frequency of the light being refracted. We assume cylindrical symmetry so that a ray of plasma light passing chordwise through the plasma at a distance x from the center is deflected through an angle given by (Ref. 4)

$$\theta_d = 2 \int_x^{r_0} dr \left(1 - \frac{x^2}{r^2} \right)^{-\frac{1}{2}} \frac{x}{r} \frac{dn}{dr} \quad (10)$$

Now, the gun plasma was constructed so that the density goes as

$$n_e(r) = \frac{x^2 n_e(x)}{r^2} \quad (11)$$

or

$$\frac{dn_e}{dr} = - \frac{2x^2 n_e(x)}{r^3} \quad (12)$$

Thus, one has

$$\theta_d = n_e(x) \left(\frac{8\pi e^2}{\omega^2 m_e} \right) \int_x^{r_0} dr \left(1 - \frac{x^2}{r^2} \right)^{-\frac{1}{2}} \frac{x^3}{r^4} \quad (13)$$

Now, the integral involved is a dimensionless quantity (Fig. 7) and may be evaluated. Over the range of interest, it assumes the value 0.55.

The effect of the spatial filter (pinhole) in the optical train, besides improving the signal-to-noise ratio, is to give the relationship of intensity on the film plane

$$\frac{\Delta I}{I} = \frac{\theta_d f}{d} \quad (14)$$

where f is the focal length of the converging lens, d is the diameter of the pinhole, and $(\Delta I/I)$ is a measure of the darkening over the setup shot, and $(\Delta I/I = 1)$ is a totally dark shadow on the film. This dark shadow corresponds to a density of

$$n_{e,max}(x) = \frac{d \omega^2 m_e}{(0.55) f 8 \pi e^2} \quad (15)$$

or, for nitrogen laser light

$$n_{e,max}(x) = 3 \times 10^{16} \text{ cm}^{-3} \quad (16)$$

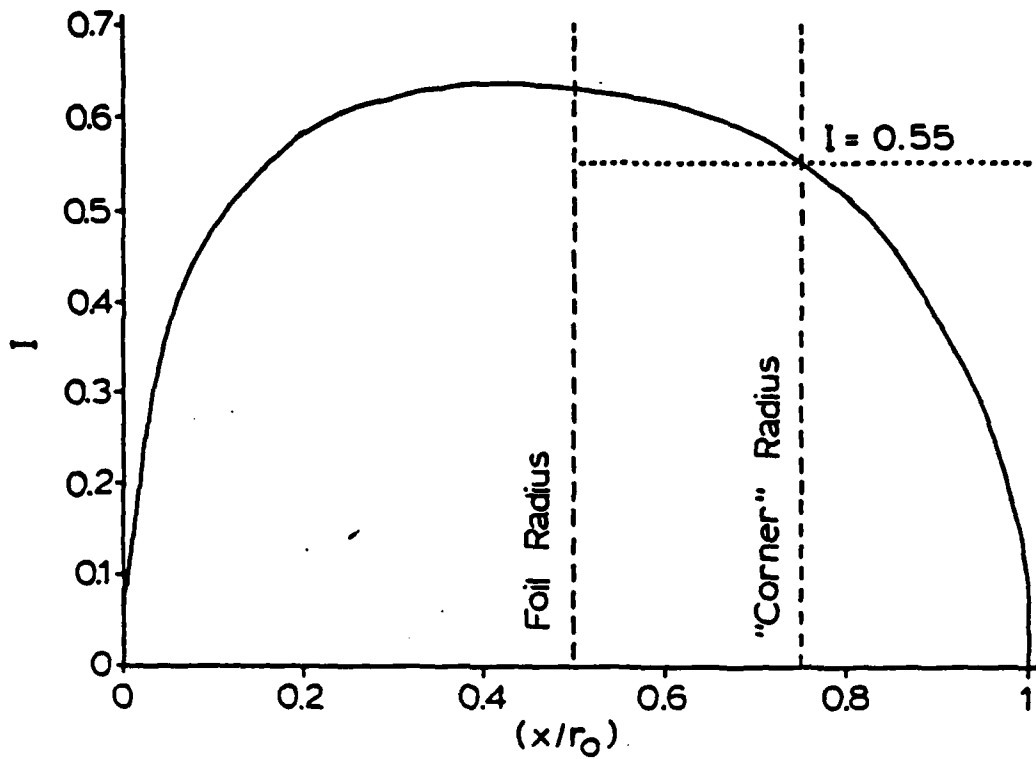

Figure 7. Dimensionless integral from Equation 13.

Thus, a dark region on the film caused by refraction is equivalent to a density of $3 \times 10^{16} \text{ cm}^{-3}$ or greater. It is important to realize that using this method of analysis gives a true density cross-section, even though the laser light passes through the plasma chordwise. Equation 10 essentially folds the effect of a chordwise view into the analysis. It is also useful to realize that the sensitivity of the shadowgraphy system may be changed by changing either the diameter of the pinhole or the focal length of the lens. However, in this respect one is limited by considerations of the signal-to-noise ratio and the ability of the lens to focus to a small spot.

CONCLUSION

An ultraviolet shadowgraphy system had been developed which is sensitive to plasma densities in the few 10^{16} cm^3 regime. It is fast enough to freeze the motion of even fast-moving plasmas, and it is capable of operating in an environment where there is a high level of both background light and electrical noise.

REFERENCES

1. J.G. Small, "A Simple Pulsed Nitrogen 3371 A Laser with a Modified Blumlein Excitation Method," Rev. Sci. Inst., 43, pp. 1205-1206, 1972.
2. C.L. Strong, "The Amateur Scientist," Sci. Am., 230(6), pp. 122-127, 1974.
3. S.L. Leonard, "Basic Macroscopic Measurements," Plasma Diagnostic Techniques, ed. R.H. Huddlestone and S.L. Leonard, Academic Press, New York, pp. 45-50, 1965.
4. M.A. Greenspan and K.V. Reddy, "A Laser Deflection Technique for Sensitive Measurements of a Reduced-Density Channel in Neutral Gas," Appl. Phys. Lett., 40(7), pp. 576-578, 1982.

END

FILMED

3-86

DTIC