

AD-A164 304

ASTROGEODETTIC--INERTIAL METHODS FOR VERTICAL DEFLECTION
DETERMINATION(U) APPLIED SCIENCE ANALYTICS INC CANOGA
PARK CA S C BOSE DEC 85 ASA-TR-85-7 ETL-0414
DACA72-84-C-0017

1/1

UNCLASSIFIED

F/G 17/7

NL

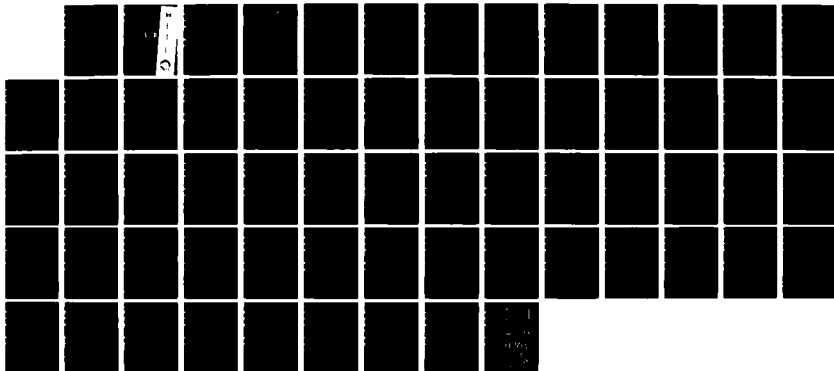

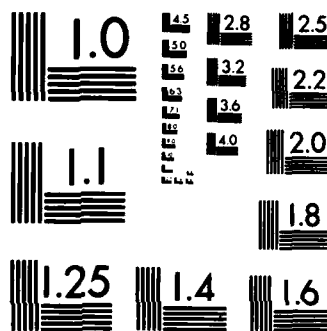

MICROCOPY RESOLUTION TEST CHART
NBS 1963-A

ETL - 0414

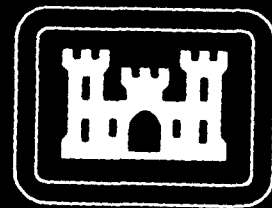

Astrogeodetic - inertial methods for vertical deflection determination

Sam C. Bose

DTIC
ELECTE
FEB 14 1986
S **D**

Applied Science Analytics, Inc.
7049 Owensmouth Avenue
Canoga Park, California 91303

December 1985

APPROVED FOR PUBLIC RELEASE; DISTRIBUTION IS UNLIMITED.

DTIC FILE COPY

Prepared for
U.S. ARMY CORPS OF ENGINEERS
ENGINEER TOPOGRAPHIC LABORATORIES
FORT BELVOIR, VIRGINIA 22060-5546

E

T

L



AD-A164 304

6 2 1 4 880

Destroy this report when no longer needed.
Do not return it to the originator.

The findings in this report are not to be construed as an official
Department of the Army position unless so designated by other
authorized documents.

The citation in this report of trade names of commercially available
products does not constitute official endorsement or approval of the
use of such products.

UNCLASSIFIED

SECURITY CLASSIFICATION OF THIS PAGE (When Data Entered)

REPORT DOCUMENTATION PAGE		READ INSTRUCTIONS BEFORE COMPLETING FORM								
1. REPORT NUMBER ETL-0414	2. GOVT ACCESSION NO. <i>AD-A164304</i>	3. RECIPIENT'S CATALOG NUMBER								
4. TITLE (and Subtitle) ASTROGEODETTIC-INERTIAL METHODS FOR VERTICAL DEFLECTION DETERMINATION		5. TYPE OF REPORT & PERIOD COVERED Final Technical Report 28 Sept 1984-28 Oct 1985								
		6. PERFORMING ORG. REPORT NUMBER ASA-TR-85-7								
7. AUTHOR(s) Dr. Sam C. Bose		8. CONTRACT OR GRANT NUMBER(s) DACA72-84-C-0017								
9. PERFORMING ORGANIZATION NAME AND ADDRESS Applied Science Analytics, Inc. 7049 Owensmouth Avenue Canoga Park, California 91303		10. PROGRAM ELEMENT, PROJECT, TASK AREA & WORK UNIT NUMBERS								
11. CONTROLLING OFFICE NAME AND ADDRESS U.S. Army Engineer Topographic Laboratories Fort Belvoir, VA 22060-5546		12. REPORT DATE December 1985								
14. MONITORING AGENCY NAME & ADDRESS (if different from Controlling Office)		13. NUMBER OF PAGES 58								
		15. SECURITY CLASS. (of this report) UNCLASSIFIED								
		15a. DECLASSIFICATION/DOWNGRADING SCHEDULE								
16. DISTRIBUTION STATEMENT (of this Report) Approved for public release; distribution is unlimited										
17. DISTRIBUTION STATEMENT (of the abstract entered in Block 20, if different from Report)										
18. SUPPLEMENTARY NOTES										
19. KEY WORDS (Continue on reverse side if necessary and identify by block number)										
<table border="0"> <tr> <td>Inertial Surveying</td> <td>Inertial error models</td> </tr> <tr> <td>Deflections of the vertical</td> <td>Kalman filter updating</td> </tr> <tr> <td>Astrogeodetic observations</td> <td>Statistical collocation</td> </tr> <tr> <td>Azimuth observation</td> <td>Least squares estimation</td> </tr> </table>			Inertial Surveying	Inertial error models	Deflections of the vertical	Kalman filter updating	Astrogeodetic observations	Statistical collocation	Azimuth observation	Least squares estimation
Inertial Surveying	Inertial error models									
Deflections of the vertical	Kalman filter updating									
Astrogeodetic observations	Statistical collocation									
Azimuth observation	Least squares estimation									
20. ABSTRACT (Continue on reverse side if necessary and identify by block number)										
<p>Considerable progress has been made in inertial surveying by the Position and Azimuth Determining System (PADS), developed by Litton Systems, Inc. for the U.S. Army Engineer Topographic Laboratories (ETL). Following the installation of an improved vertical accelerometer and other modifications, the PADS has been renamed Inertial Positioning System (IPS). The IPS, with some</p>										

20. ABSTRACT (cont)

software changes as to gyro error control has served as the Rapid Gravity Survey System (RGSS) for ETL. The present RGSS operates as a quasi-local level system and permits Kalman stochastic error control using observed velocity errors at vehicle stops. A new optimal data reduction method for estimating the deflections of the vertical is presented. The method requires RGSS horizontal velocity errors at each stop and the inertial system real-time Kalman filter update gains. Storage of real-time covariance data is not necessary. Survey traverse initial and terminal astrogeodetic deflections are utilized along with terminal platform azimuth error observation to estimate approximate gyro biases. The error models used preserve the inertial system dual horizontal interaction and exploits statistical collocation techniques to preserve correlations between the two components of the deflection of the vertical which are least squares estimated using all data simultaneously.

ASA-TR-85-7

**ASTROGEODETIC-INERTIAL METHODS FOR
VERTICAL DEFLECTION DETERMINATION**

by

Dr. Sam C. Bose

for

**U.S. ARMY CORPS OF ENGINEERS
ENGINEER TOPOGRAPHIC LABORATORIES
FORT BELVOIR, VIRGINIA 22060-5546**

Under

Contract No. DACA72-84-C-0017

DECEMBER 1985



APPLIED SCIENCE ANALYTICS, INC.

7049 OWENSMOUTH AVENUE, CANOGA PARK, CA 91303 • (818) 716-1237



PREFACE

This document is generated under Contract DACA72-84-C-0017 for the U.S. Army Engineer Topographic Laboratories, Fort Belvoir, Virginia, 22060-5546, by Applied Science Analytics, Inc., Canoga Park, California, 91303. The Contracting Officer's Technical Representative (COTR) was Dr. Hans Baussus von Luetzow, ETL-RI-C.

Accession For	
NTIS CRA&I	<input checked="" type="checkbox"/>
DTIC TAB	<input type="checkbox"/>
Unannounced	<input type="checkbox"/>
Justification	
By	
Distribution/	
Availability Codes	
Dist	Avail and/or Special
A-1	





ACKNOWLEDGEMENT

The technical study presented in this report was motivated by the numerous publications of Dr. Hans Baussus von Luetzow of the U.S. Army Engineer Topographic Laboratories Research Institute. Techniques developed by him served as the foundation for the research reported herein. His contributions in this field are acknowledged and his technical guidance during the contract is greatly appreciated.



TABLE OF CONTENTS

Paragraph	Title	Page
1.0 INTRODUCTION		
1.1	BACKGROUND.....	1-1
1.2	PURPOSE AND SCOPE.....	1-5
1.3	TECHNICAL APPROACH.....	1-5
1.4	OVERVIEW OF REPORT.....	1-6
2.0 ERROR MODELS		
2.1	LOCAL LEVEL NORTH POINTING.....	2-1
2.2	LAND SURVEY VEHICLE APPROXIMATIONS.....	2-4
2.3	FURTHER ASSUMPTIONS TO OBTAIN REDUCED SET.....	2-5
3.0 CLOSED FORM SOLUTION		
3.1	TIME INVARIANT DYNAMICS MATRIX SOLUTION.....	3-1
3.2	DETERMINATION OF EIGENVALUES/EIGENVECTORS.....	3-6
4.0 TRANSITION MATRICES		
4.1	VEHICLE STOP PERIODS.....	4-1
4.2	VEHICLE MOTION PERIODS.....	4-1
4.3	KALMAN FILTER UPDATING.....	4-10
4.4	STOP/MOTION/UPDATING COMBINED.....	4-12



TABLE OF CONTENTS (cont)

Paragraph	Title	Page
5.0 OBSERVATION EQUATION		
5.1	GENERALIZED FORM AT EACH STOP POINT.....	5-1
5.2	LINEAR COMBINATION OF UNKNOWN DEFLECTIONS.....	5-2
5.3	GYRO DRIFT RATES APPROXIMATED AS CONSTANTS.....	5-4
5.4	SEPARATION OF GYRO DRIFT RATES FROM UNKNOWN DEFLECTIONS.....	5-5
6.0 ESTIMATION METHODS		
6.1	INITIAL CONDITION SPECIFICATIONS.....	6-1
6.2	CONSTANT GYRO BIAS ESTIMATION FROM TERMINAL DATA.....	6-1
6.3	COEFFICIENT ESTIMATION VIA STATISTICAL COLLOCATION.....	6-2
6.4	LEAST SQUARES ESTIMATION OF DEFLECTIONS.....	6-3
7.0 CONCLUSIONS		
7.1	SUMMARY.....	7-1
7.2	RECOMMENDATIONS.....	7-2
	REFERENCES.....	Ref-1



LIST OF ILLUSTRATIONS

Figure	Title	Page
2-1	Local Level, North Pointing Inertial Error Block Diagram.....	2-2
4-1	Motion Period Acceleration Profile.....	4-3
4-2	Stop/Motion/Updating Periods.....	4-13

LIST OF TABLES

Table	Title	Page
2-1	DEFINITION OF LOCAL LEVEL NORTH POINTING ERROR VARIABLES.....	2-3



1.0 INTRODUCTION

1.1 BACKGROUND

The U.S. Army Engineer Topographic Laboratories (USAETL) awarded a contract to Litton Systems, Inc., Guidance and Control Systems Division (LITTON GCSO) back in 1966 to determine the feasibility of utilizing an inertial navigation system in a surveying application (Clark, 1966). Subsequent studies (Maughmer and Yamamoto, 1968; Maughmer and Byrd, 1969) led to the feasibility and practicality of the Position and Azimuth Determining System (PADS).

Following these studies the USAETL awarded a contract to develop an experimental PADS in February, 1971. Acceptance tests were completed in November 1972 and reported on at the Institute of Navigation's 28th Annual Meeting at West Point (Huddle and Maughmer, 1972). Subsequently Ellms (1973) wrote a report on the design, fabrication and testing of the PADS which was capable of measuring the change in horizontal position to 20 meters (CEP), elevations to 10 meters (1σ), and azimuth to 0.3 mils (1σ) at various test sites in the continental United States for missions of six hours duration and covering distances of 120 miles. These accuracies were achieved while requiring the vehicle to come to a stop for only approximately 20 seconds following a travel period of roughly 10 minutes. At such times, observations of the residual values of the computed velocities along all three platform axes are processed by the PADS real time Kalman error control mechanization to correct system computed position, velocity, and platform attitude, and to compensate various sources of system noise. It did not require any external



position or azimuth information during the mission or at mission closure to achieve these accuracies.

Subsequently USAETL wanted to explore the possibility of using PADS for gravity surveying. Huddle (1973) examined the application of the PADS to mapping, charting and geodesy wherein he concluded that 'great potential exists for improving the continuous estimates of the change in the deflection of the vertical between the initial and the terminating point of the mission through the use of optimal smoothing techniques which employ a deflection change observation at the mission termination point.' For a one hour mission this study showed that near term performance limits of 12 to 60 cm (1σ) for elevation, 2 to 3 milligals (1σ) for anomaly and 1.5 arc sec (1σ) for deflection are achievable provided that: 1) certain parameter value changes were made in the real-time Kalman filter, 2) vertical A-200D accelerometers were replaced by the higher accuracy A1000 accelerometers, 3) the Inertial Measurement Unit (IMU) was isolated or engine turned off during zero velocity measurements and 4) post-mission smoothing of real-time filtered estimates were performed.

As a result of this an experimental study contract was awarded to Litton Systems Guidance and Control Systems Division in 1974 to determine if replacement of vertical axis A-200D with A-1000 accelerometer allows determination of gravity disturbance magnitude to 2 milligals. The results of this experimental study indicated that the running of engine during measurement leads to excessive errors (3 to 4 μ g) due to front-end mounting and that with engine off accuracies of 1 to 2 milligals is achievable. The results of this study was published by Mancini and Huddle at the 35th Annual Meeting of the American Congress on Surveying and Mapping in March 1975.



Following the installation of the higher accuracy vertical accelerometer and other modifications, the PADS was renamed Inertial Positioning System (IPS). Subsequently in 1975 LITTON GCSD was awarded a contract to configure the IPS as a gravity surveying system which came to be known as the Rapid gravity Survey System (RGSS). During this contract Litton investigated the changes necessary to configure RGSS from IPS. This resulted in some changes in gyro error control mechanization of the real time Kalman filter (Huddle, 1977). During this contract Litton also examined techniques of post-mission smoothing to improve performance and analyzed data collected by UASETL at White Sands. Their results indicated a potential 1.5 arcsec recovery capability with Kalman post-mission smoothing. The first analysis of RGSS deflection data obtained by USAETL appeared in Huddle and Lentz (1976).

Subsequent to this during 1977 and 1978 LITTON GCSD was awarded another contract to perform further analytical studies to improve performance of RGSS. The objectives of this study were to reach performance goals of 1 milligal for gravity anomaly and 1 arcsec for the deflection of the vertical for 1 hour mission time. This study derived deflection recovery performance limitations due to integrated correlated drift rate, the results of which were discussed at the First International Symposium on Inertial Technology for Surveying and Geodesy and also in a paper in the AIAA Journal of Guidance and Control (Huddle, 1978). In order to achieve such performance goals the study recommended additional modifications to the RGSS: 1) Super pre-calibrate systematic errors, especially heading change sensitive effects or run straight traverses only in order to achieve accelerometer biases of 0.5 to 1 μ g and gyro drift rate of 0.001 deg/hr, 2) Obtain better isolation of system from random motion at stops in order to achieve observation accuracy of 0.001 feet/sec at 10 seconds,



3) ensure accurate deflection values are used by post-mission smoother of the order of 0.1 to 0.3 arcsec. As a result of this, this study recommended: 1) investigation of more extensive pre-mission calibration techniques, 2) testing to determine systematic content of heading sensitive instrument errors and noise content of level A-200D accelerometers and 3) modification/expansion of mission data recording to enable more effective post-mission analysis.

Following this, during the latter part of 1980, USAETL awarded a contract to LITTON GCSO for the development, test, preparation, delivery and installation of optimal adjustment software for inertial survey data. The objective of this contract was to develop alternative minimum variance algorithms for simultaneous adjustment of three axes position and gravity data applicable for single traverse and multiple traverses. This effort culminated in a software package for area adjustment of multitraverse RGSS data. This software package is called the Regional Adjustment Program (RAP) which was delivered and installed on the DEC VAX 11/780 of Defense Mapping Agency (DMA) geodetic survey squadron. A series of reports (Huddle, Brockstein, Buchler and Bose, April 1981, June 1981a,b, August 1982) were written to document the efforts on this contract. The conclusion in these reports was that near term performance goals of 0.3 arcsec can nearly be met with existing equipment provided survey measurements are processed utilizing some area adjustment program such as RAP.

Subsequently Baussus von Luetzow (1981, 1982) developed a coupled horizontal channel optimal method of vertical deflection determination in the context of Litton's local-level system.



This study extends on this and develops the algorithms necessary to implement the method of Baussus von Luetzow.

1.2 PURPOSE AND SCOPE

The objective of this study is to review and analyze astrogeodetic-inertial methods for determination of the vertical deflections. Methods of vertical deflection determination developed by Litton Systems, Inc. and the U.S. Army Engineer Topographic Laboratories is taken under consideration to the extent published in the context of Litton's local-level system. The scope of the effort is restricted to the development of all the algorithms necessary so as to create the foundation upon which optimal adjustment software can be developed for large scale simulation or actual field data processing. The scope of the study does not include any software development but to carry through the development of the algorithms to the point where they are complete and no further work be necessary on algorithm development.

1.3 TECHNICAL APPROACH

The overall technical approach in this study is to examine the method of Baussus von Luetzow in detail and develop all the necessary algorithms to work in conjunction with the Litton inertial surveying systems. The algorithms are developed taking into account not only the present state of the hardware but also future hardware improvements. The real-time software on-board the Litton inertial surveying systems is an important consideration since the design of post mission estimation methods must invariably take into account any on-line corrections. The approach taken in this study is to design the algorithms for post-mission processing in a way that takes into account the on-line corrections made by the on-board software but does not



require any changes or modifications to the on-board software thereby minimizing the impact on real-time software changes.

1.4 OVERVIEW OF REPORT

This report is organized as follows. Chapter 2 investigates the applicable error models. In this chapter, first the general local level north pointing error model is reviewed, which is then approximated for land survey vehicle applications from which a reduced set of error equations are obtained based on further appropriate assumptions. Closed form solutions of the reduced set of error equations are presented in Chapter 3 wherein first the time invariant dynamics matrix solution is written followed by the appropriate eigenvalues and eigenvectors necessary for the solution. In Chapter 4 the transition matrices during vehicle stop periods, motion periods and Kalman filter updating are obtained. The observation equation is derived in Chapter 5 wherein first a generalized form at each point is presented which is then reduced to separate the unknown gyro drift rates from the unknown vertical deflections. In Chapter 6 the different estimation methods are outlined for the initial conditions, gyro bias, unknown coefficients and finally the vertical deflections. Summary and recommendations are discussed in Chapter 7.



2.0 ERROR MODELS

2.1 LOCAL LEVEL NORTH POINTING

The central error dynamics of concern here is that of the inertial system. Huddle (1982) has presented the pertinent equations along with suitable approximations to be used for an on-line Kalman filter design. For a local level north pointing inertial navigation system the error differential equations are (for the horizontal channels only):

$$\begin{aligned}\dot{\delta\phi} &= -\delta\rho_E + \rho_N (\delta\lambda \sin \phi) - \rho_Z (\delta\lambda \cos \phi) \\ \dot{\delta\lambda \cos \phi} &= \delta\rho_N + \rho_Z \delta\phi + \rho_E (\delta\lambda \sin \phi) \\ \dot{\delta V_E} &= A_N \phi_Z - g \phi_N + (\rho_Z + 2\Omega_Z) \delta V_N \\ &\quad + V_N \delta\rho_Z + 2V_N \Omega_N \delta\phi + \nabla_E \\ \dot{\delta V_N} &= -A_E \phi_Z + g \phi_E - (\rho_Z + 2\Omega_Z) \delta V_E \\ &\quad - V_E \delta\rho_Z - 2V_E \Omega_N \delta\phi + \nabla_N \\ \dot{\phi_E} &= \delta\rho_E - (\Omega_N + \rho_N) \phi_Z + (\Omega_Z + \rho_Z) \phi_N + \\ &\quad \Omega_N (\delta\lambda \sin \phi) - (\Omega_Z + \rho_Z) (\delta\lambda \cos \phi) \\ &\quad + \epsilon_E \\ \dot{\phi_N} &= \delta\rho_N - (\Omega_Z + \rho_Z) \phi_E + \rho_E \phi_Z - \Omega_Z \delta\phi + \epsilon_N \\ \dot{\phi_Z} &= \delta\rho_Z - \rho_E \phi_N + (\Omega_N + \rho_N) \phi_E + \Omega_N \delta\phi + \epsilon_Z \quad (2.1)\end{aligned}$$

where figure 2-1 is a block diagram of the error equations and table 2-1 gives a definition of all the variables.

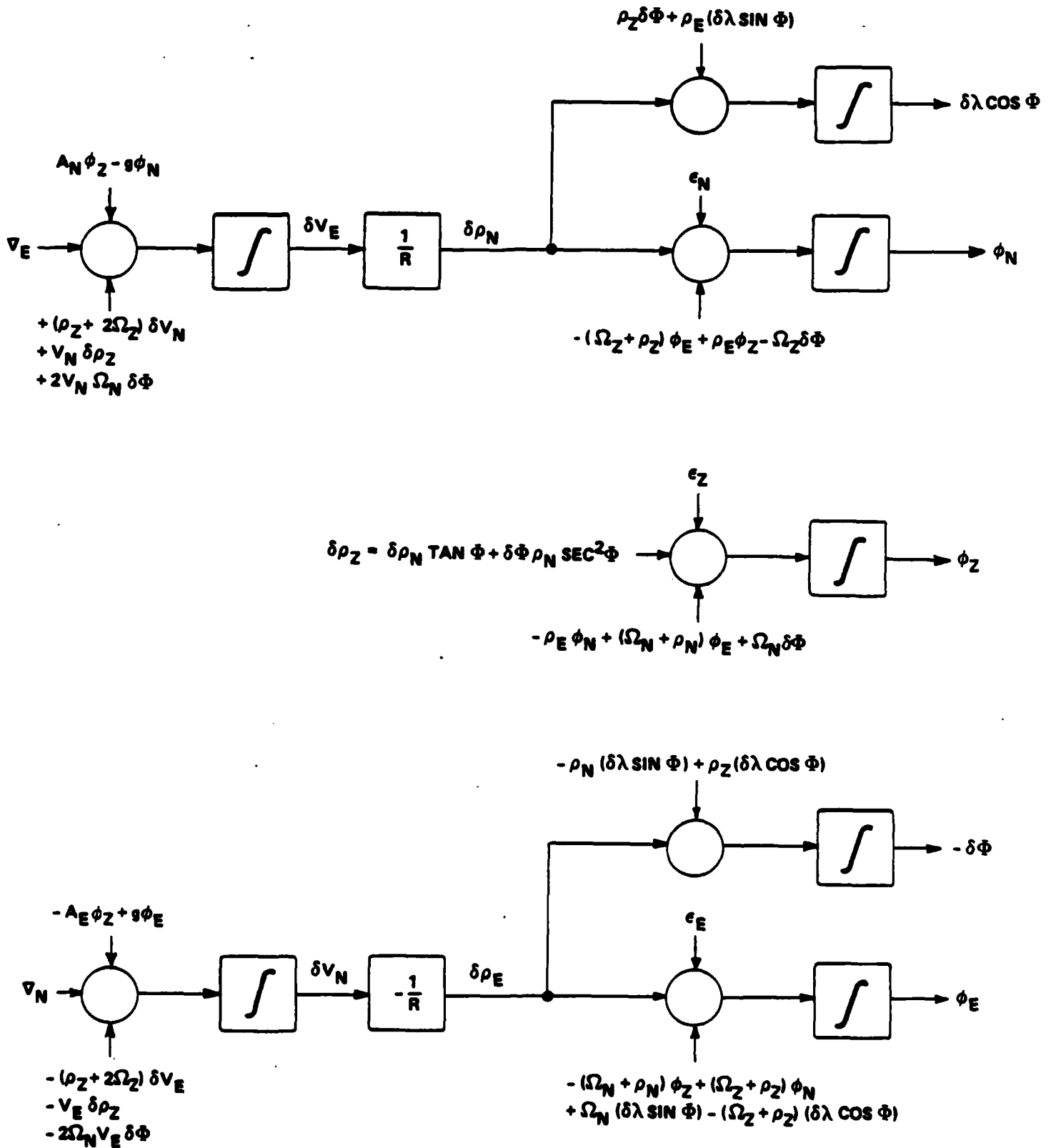

Figure 2-1. Local Level, North Pointing Inertial Error Block Diagram

USE OR DISCLOSURE OF DOCUMENT DATA IS SUBJECT TO THE RESTRICTION ON THE TITLE PAGE OF THIS DOCUMENT.



TABLE 2-1. DEFINITION OF LOCAL LEVEL NORTH POINTING
ERROR VARIABLES

$\rho_E = -V_N/R$	= East craft rate
$\rho_N = V_E/R$	= North craft rate
$\rho_Z = (V_E/R) \tan \phi$	= Vertical craft rate
g	= Vertical gravity vector component
R	= Earth's mean radius
V_E, V_N	= System's east, north velocity
ϕ	= Geographic latitude
Ω	= Earth's inertial angular velocity
$\Omega_N = \Omega \cos \phi$	= North component of Earth's angular velocity
$\Omega_Z = \Omega \sin \phi$	= Vertical component of Earth's angular velocity
A_E, A_N	= East, north components of vehicle's specific force
$\delta \rho_E = -\delta V_N/R$	= East craft rate error
$\delta \rho_N = \delta V_E/R$	= North craft rate error
$\delta \rho_Z = \delta \rho_N \tan \phi + \delta \phi \rho_N \sec^2 \phi$	= Vertical craft rate error
$\delta V_E, \delta V_N$	= East, north velocity error
$\delta \phi$	= Latitude error (North angular position error)
$\delta \lambda$	= Longitude error
$\delta \lambda \cos \phi$	= East angular position error
ϕ_E, ϕ_N, ϕ_Z	= East, north, vertical platform attitude error
∇_E, ∇_N	= Composite east, north accelerometer error
$\epsilon_E, \epsilon_N, \epsilon_Z$	= Composite east, north, vertical gyro drift



2.2 LAND SURVEY VEHICLE APPROXIMATIONS

Considering the fact that the survey vehicle moves slowly over relatively short distances various approximations can be made without impacting on the validity of the error equations. First, the errors due to errors in the coriolis corrections can be ignored. These are the errors proportional to δV_N , δV_E , $\delta \rho_Z$ and $\delta \phi$. Second, the errors proportional to position error ($\delta \lambda$, $\delta \phi$) can be ignored except for $\Omega_N \delta \phi$, which is an important azimuth, level coupling term. Because of the accuracy of initialization, the periodic null velocity updating and the low vehicle speed, these position error coupling terms represent very small equivalent gyro drift rates. Finally those terms containing ρ_E , ρ_N and ρ_Z can be ignored because of the low vehicle speed compared to earth rate. This reduces the error equations to

$$\begin{aligned} R \dot{\delta \phi} &= \delta V_N \\ R(\dot{\delta \lambda} \cos \phi) &= \delta V_E \\ \dot{\delta V_E} &= A_N \phi_Z - g \phi_N + g \eta + \nabla_E \\ \dot{\delta V_N} &= -A_E \phi_Z + g \phi_E - g \xi + \nabla_N \\ \dot{\phi_E} &= -\delta V_N / R - \Omega_N \phi_Z + \Omega_Z \phi_N + \epsilon_E \\ \dot{\phi_N} &= \delta V_E / R - \Omega_Z \phi_E + \epsilon_N \\ \dot{\phi_Z} &= (1/R \tan \phi) \delta V_E + \Omega_N \delta \phi + \Omega_N \phi_E + \epsilon_Z \end{aligned} \quad (2.2)$$

where the terms $g \eta$ and $g \xi$ (the north and east deflections) have been explicitly extracted from ∇_E and ∇_N respectively. These equations agree with those of Baussus von Luetzow (1983).



2.3 FURTHER ASSUMPTIONS TO OBTAIN REDUCED SET

The following assumptions are invoked:

- a. Under accelerometer bias calibration ∇_E and ∇_N are assumed to be calibrated out.
- b. The horizontal accelerations A_E and A_N are neglected for the time being.
- c. Longitude error dynamics is neglected since the differential equations for the horizontal velocity errors have no coupling to longitude error $\delta\lambda$.

Under the above assumptions the error equations given by (2.2) reduce to

$$\begin{aligned}\dot{\delta V}_N &= +g\phi_E - g\xi \\ R\dot{\delta\phi} &= \delta V_N \\ \dot{\delta V}_E &= -g\phi_N + g\eta \\ \dot{\phi}_Z &= (1/R \tan \phi) \delta V_E + \Omega_N \delta\phi + \Omega_N \phi_E + \epsilon_Z \\ \dot{\phi}_N &= \delta V_E/R - \Omega_Z \phi_E + \epsilon_N \\ \dot{\phi}_E &= -\delta V_N/R - \Omega_N \phi_Z + \Omega_Z \phi_N + \epsilon_E\end{aligned}\tag{2.3}$$

which can be written as



$$\frac{d}{dt} \begin{bmatrix} \delta V_N \\ \delta V_E \\ R\delta\phi \\ \phi_Z \\ \phi_N \\ \phi_E \end{bmatrix} = \begin{bmatrix} 0 & 0 & 0 & 0 & 0 & g \\ 0 & 0 & 0 & 0 & -g & 0 \\ 1 & 0 & 0 & 0 & 0 & 0 \\ 0 & \frac{1}{R} \tan\phi & \frac{\Omega \cos\phi}{R} & 0 & 0 & \Omega \cos\phi \\ 0 & \frac{1}{R} & 0 & 0 & 0 & -\Omega \sin\phi \\ -\frac{1}{R} & 0 & 0 & -\Omega \cos\phi & \Omega \sin\phi & 0 \end{bmatrix} \begin{bmatrix} \delta V_N \\ \delta V_E \\ R\delta\phi \\ \phi_Z \\ \phi_N \\ \phi_E \end{bmatrix} + \begin{bmatrix} -g\epsilon \\ g\eta \\ 0 \\ \epsilon_Z \\ \epsilon_N \\ \epsilon_E \end{bmatrix}$$

(2.4)

or

$$\dot{\mathbf{y}} = \mathbf{Ay} + \mathbf{b}$$

(2.5)



3.0 CLOSED FORM SOLUTION

3.1 TIME INVARIANT DYNAMICS MATRIX SOLUTION

As can be easily seen from (2.4) the coefficients of the dynamics matrix A include:

- a. Mean radius of the earth, R
- b. Earth's inertial angular velocity, Ω
- c. Geographic latitude, ϕ

For the applications under consideration it can be assumed that R, Ω , ϕ are constant between stops of the survey vehicle. This leads to a time invariant dynamics matrix A for which the closed form solution to (2.5) is given by Brogan (1974) as

$$y(t) = e^{At} y(0) + \int_0^t e^{A(t-\tau)} b(\tau) d\tau \quad (3.1)$$

which reduces to

$$y(t) = e^{At} y_0 + A^{-1} (e^{At} - I) b_0 \quad (3.2)$$

where $b(0)$ was assumed to be constant over the integration interval.



Now, if λ_i are the eigenvalues of A and μ_i the corresponding eigenvectors, then

$$A\mu_i = \mu_i \lambda_i \quad (3.3)$$

such that

$$A \left[\begin{array}{c|c|c|c} \mu_1 & \mu_2 & \dots & \mu_n \end{array} \right] = \left[\begin{array}{c|c|c|c} \mu_1 & \mu_2 & \dots & \mu_n \end{array} \right] \begin{bmatrix} \lambda_1 & & & 0 \\ & \lambda_2 & & \\ & & \dots & \\ 0 & & & \lambda_n \end{bmatrix} \quad (3.4)$$

or

$$AM = M\Lambda \quad (3.5)$$

where

$$M = \left[\begin{array}{c|c|c|c} \mu_1 & \mu_2 & \dots & \mu_n \end{array} \right] \quad (3.6)$$

and

$$\Lambda = \begin{bmatrix} \lambda_1 & & & & & & 0 \\ & \lambda_2 & & & & & \\ & & \dots & & & & \\ & & & \dots & & & \\ & & & & \dots & & \\ & & & & & \dots & \\ 0 & & & & & & \lambda_n \end{bmatrix} \quad (3.7)$$



Therefore, from (3.5)

$$A = M\Lambda M^{-1} \quad (3.8)$$

which leads to

$$\begin{aligned} e^{At} &= I + At + \frac{1}{2} A^2 t^2 + \dots \\ &= I + M\Lambda M^{-1}t + \frac{1}{2} M\Lambda M^{-1}M\Lambda M^{-1}t^2 + \dots \\ &= MIM^{-1} + M\Lambda tM^{-1} + M\frac{1}{2}\Lambda^2 t^2 M^{-1} + \dots \\ &= M(I + \Lambda t + \frac{1}{2}\Lambda^2 t^2 + \dots)M^{-1} \\ &= Me^{\Lambda t}M^{-1} \end{aligned} \quad (3.9)$$

Similarly,

$$\begin{aligned} A^{-1}(e^{At}-I) &= A^{-1}(I + At + \frac{1}{2}A^2 t^2 + \dots - I) \\ &= A^{-1}(At + \frac{1}{2}A^2 t^2 + \dots) \\ &= It + \frac{1}{2}At^2 + \dots \end{aligned}$$



$$\begin{aligned} &= It + \frac{1}{2} M \Lambda M^{-1} t^2 + \dots \\ &= M I t M^{-1} + M \frac{1}{2} \Lambda t^2 M^{-1} + \dots \\ &= M (It + \frac{1}{2} \Lambda t^2 + \dots) M^{-1} \\ &= M \Lambda^{-1} (e^{\Lambda t} - I) M^{-1} \end{aligned} \tag{3.10}$$

Hence, substituting (3.9) and (3.10) in (3.2) yields

$$\begin{aligned} y(t) &= M e^{\Lambda t} M^{-1} y_0 + M \Lambda^{-1} (e^{\Lambda t} - I) M^{-1} b_0 \\ &= T y_0 + \Psi b_0 \end{aligned} \tag{3.11}$$

where

$$T = M e^{\Lambda t} M^{-1} \tag{3.12}$$

$$\Psi = M \Lambda^{-1} (e^{\Lambda t} - I) M^{-1} \tag{3.13}$$



Recall that

$$y(t) = \begin{bmatrix} y_1(t) \\ y_2(t) \\ y_3(t) \\ y_4(t) \\ y_5(t) \\ y_6(t) \end{bmatrix} = \begin{bmatrix} \delta V_N(t) \\ \delta V_E(t) \\ R\delta\phi(t) \\ \phi_Z(t) \\ \phi_N(t) \\ \phi_E(t) \end{bmatrix} \quad (3.14)$$

For each individual element of $y(t)$ of (3.14) denoted as $y_i(t)$ we have

$$y_i(t) = \sum_{j=1}^6 M(i,j) e^{\lambda_j t} \sum_{k=1}^6 M^{-1}(j,k) y_0(k) + \sum_{j=1}^6 M(i,j) \frac{1}{\lambda_j} (e^{\lambda_j t} - 1) \sum_{k=1}^6 M^{-1}(j,k) b_0(k) \quad i = 1, 2, \dots, 6 \quad (3.15)$$



3.2 DETERMINATION OF EIGENVALUES/EIGENVECTORS

The dynamics matrix A given by (2.4) has a characteristic equation as

$$\lambda^6 + \lambda^4 (2\Omega_s^2 + \Omega^2) + \lambda^2 (\Omega_s^4 + \Omega_s^2 \Omega^2 \sin^2 \phi) - \Omega^2 \Omega_s^4 \cos^2 \phi = 0 \quad (3.16)$$

which has roots

$$\lambda = \pm i\Omega_s, \pm i\Omega', \pm K \quad (3.17)$$

where

$$\Omega_s^2 = \left(\frac{g}{R}\right)^{1/2} \quad (3.18)$$

is the Schuler frequency and

$$\Omega' = \left[\frac{1}{2} (\Omega_s^2 + \Omega^2) + \frac{1}{2} \left\{ \Omega_s^4 + 2\Omega_s^2 \Omega^2 (1 + 2 \cos^2 \phi) + \Omega^4 \right\}^{1/2} \right]^{1/2} \quad (3.19)$$

$$\approx \left\{ \Omega_s^2 + \Omega^2 (1 + \cos^2 \phi) \right\}^{1/2} \quad (3.20)$$

and

$$K = \left[\frac{1}{2} \left\{ \Omega_s^4 + 2\Omega_s^2 \Omega^2 (1 + 2 \cos^2 \phi) + \Omega^4 \right\}^{1/2} - \frac{1}{2} (\Omega_s^2 + \Omega^2) \right]^{1/2} \quad (3.21)$$

$$\approx \Omega \cos \phi \quad (3.22)$$



The eigenvectors are

$$\mu_i = \begin{bmatrix} \frac{g}{\lambda_i} (\lambda_i^2 + \Omega_s^2) \\ g\Omega \sin\phi \\ \frac{g}{\lambda_i} (\lambda_i^2 + \Omega_s^2) \\ - \left\{ (\lambda_i^2 + \Omega_s^2)^2 + \lambda_i^2 \Omega^2 \sin^2\phi \right\} / \lambda_i \Omega \cos\phi \\ - \lambda_i \Omega \sin\phi \\ \lambda_i^2 + \Omega_s^2 \end{bmatrix} \quad (3.23)$$

where μ_i refers to the eigenvector associated with the i th eigenvalue. Thus the modal matrix M is now completely specified. To specify M^{-1} the eigenvectors of the adjoint matrix is necessary. The adjoint matrix is given by A^T , which has the same eigenvalues as A . Let the eigenvectors of the adjoint matrix A^T be represented by θ_i . Then

$$A^T \theta_i = \lambda_i \theta_i \quad (3.24)$$

which leads to

$$A^T \left[\theta_1 \mid \theta_2 \mid \dots \mid \theta_n \right] = \left[\theta_1 \mid \theta_2 \mid \dots \mid \theta_n \right] \begin{bmatrix} \lambda_1 & & & 0 \\ & \lambda_2 & & \\ & & \cdot & \\ 0 & & & \lambda_n \end{bmatrix} \quad (3.25)$$



or

$$A^T N = N \Lambda \quad (3.26)$$

where the modal matrix for the adjoint matrix A^T is

$$N = [\theta_1 | \theta_2 | \dots | \theta_N] \quad (3.27)$$

and the eigenvalue matrix Λ is same as before given by (3.7)

Thus, from (3.26)

$$A^T = N \Lambda N^{-1} \quad (3.28)$$

which leads to

$$A = (N^T)^{-1} \Lambda N^T \quad (3.29)$$

Comparing (3.29) with (3.8) leads to

$$M^{-1} = N^T$$

Thus, solution of the eigenvectors for the adjoint problem completely specifies the inverse modal matrix.



The eigenvectors of the adjoint problem are

$$\theta_i = a_i^{-1} \begin{bmatrix} (\lambda_i^2 + \Omega_s^2) (\Omega^2 \cos^2 \phi - \lambda_i^2) / R \\ 2\lambda_i^3 \Omega \sin \phi / R \\ \Omega^2 \cos \phi \lambda_i (\lambda_i^2 + \Omega_s^2) / R \\ - \Omega \cos \phi \lambda_i^2 (\lambda_i^2 + \Omega_s^2) \\ \Omega \sin \phi \lambda_i^2 (\lambda_i^2 - \Omega_s^2) \\ \lambda_i^3 (\lambda_i^2 + \Omega_s^2) \end{bmatrix} \quad (3.30)$$

where

$$a_i = 4\lambda_i^2 \Omega^2 \Omega_s^2 \sin^2 \phi + 2(\lambda_i^2 + \Omega_s^2) (\lambda_i^4 + \Omega^2 \Omega_s^2 \cos^2 \phi) / \lambda_i \quad (3.31)$$

is the normalizing factor such that

$$\theta_i^T \cdot \mu_j = \delta_{ij} \quad (3.32)$$

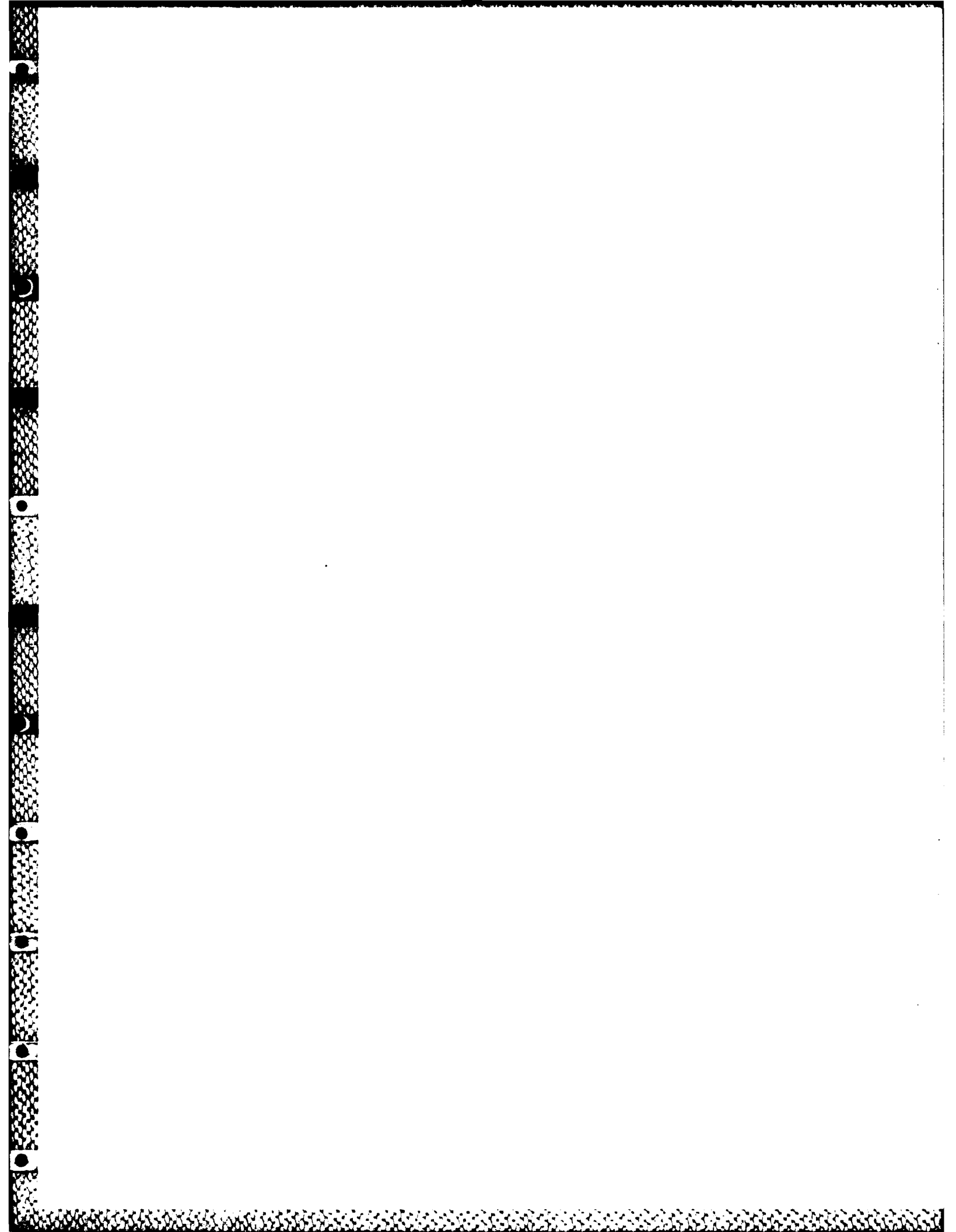



4.0 TRANSITION MATRICES

4.1 VEHICLE STOP PERIODS

During vehicle stop periods the horizontal accelerations A_E and A_N are assumed to be zero. Therefore, the dynamics matrix A of (2.4) is exact during the stop period. Consequently, the stop period transition matrices for the initial conditions y_0 and for the drivers b_0 are equal to those given by (3.12) and (3.13). Therefore, during stop periods

$$T_S = T \quad (4.1)$$

and

$$\Psi_S = \Psi \quad (4.2)$$

4.2 VEHICLE MOTION PERIODS

During the motion period the horizontal vehicle accelerations A_E and A_N are not zero. Thus, in order to compensate for setting A_E and A_N to zero in the dynamics matrix A we try a perturbation addition to the solution $y(t)$.

Comparing (2.2) and (2.3) the neglected terms are identified as

$$\dot{\delta V}_N = -A_E \phi_Z \quad (4.3)$$

$$\dot{\delta V}_E = A_N \phi_Z \quad (4.4)$$



Thus,

$$\delta V_N = - \int_0^t A_E(\tau) \phi_Z(\tau) d\tau \quad (4.5)$$

and

$$\delta V_E = \int_0^t A_N(\tau) \phi_Z(\tau) d\tau \quad (4.6)$$

The above integrals (4.5) and (4.6) could be integrated numerically given the functional form of A_E and A_N . However, since the integration time is expected to be no more than ten (10) minutes a Taylor series expansion for ϕ_Z is appropriate. But since every motion period is bounded on either side by a stop period it is likely that the acceleration of the vehicle will be close to an odd function about the midpoint of the motion period interval. For example, figure 4-1 is one possible form of the acceleration profile during the motion period, bounded on either side by stop periods. For such an acceleration profile as shown in figure 4-1, its functional form is given by

$$a(t) = \begin{cases} + A & 0 \leq t \leq \frac{T}{2} \\ - A & \frac{T}{2} \leq t \leq T \end{cases} \quad (4.7)$$

This suggests expanding the Taylor series for ϕ_Z about the midpoint of the motion period interval, T . Thus,

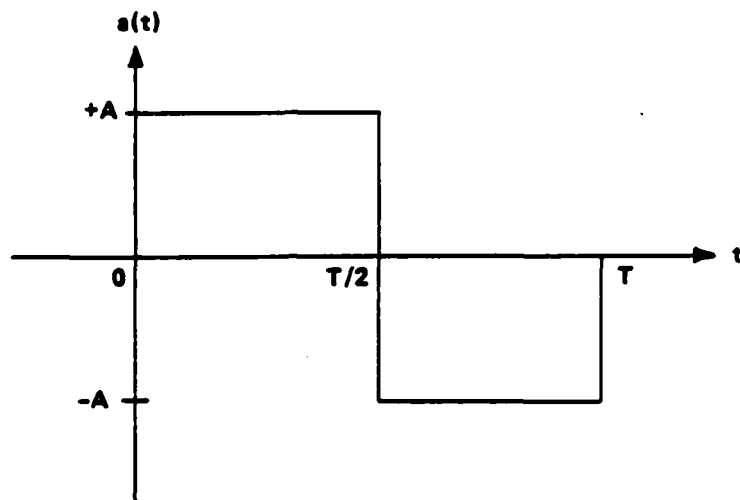

Figure 4-1. Motion Period Acceleration Profile



$$\phi_z(t) = \underbrace{\phi_z(t) \Big|_{t=T/2}}_{\phi_{z0}} + \underbrace{\frac{d\phi_z(t)}{dt} \Big|_{t=T/2}}_{\phi_{z1}} (t - \frac{T}{2}) + \frac{1}{2} \underbrace{\frac{d^2\phi_z(t)}{dt^2} \Big|_{t=T/2}}_{\phi_{z2}} (t - \frac{T}{2})^2 + \dots \quad (4.8)$$

Let us first examine the third term, ϕ_{z2} in the above expansion (4.8) in conjunction with the assumed acceleration form given by (4.7).

$$\int_0^T a(t) \phi_{z2}(t) dt$$

$$= \int_0^{T/2} A \frac{1}{2} \frac{d^2\phi_z(t)}{dt^2} \Big|_{t=T/2} (t - \frac{T}{2})^2 dt - \int_{T/2}^T A \frac{1}{2} \frac{d^2\phi_z(t)}{dt^2} \Big|_{t=T/2} (t - \frac{T}{2})^2 dt$$

$$= \frac{A}{2} \frac{d^2\phi_z(t)}{dt^2} \Big|_{t=T/2} \left\{ \int_0^{T/2} (t - T/2)^2 dt - \int_{T/2}^T (t - T/2)^2 dt \right\}$$

$$= \frac{A}{2} \frac{d^2\phi_z(t)}{dt^2} \Big|_{t=T/2} \left\{ \int_{-T/2}^0 t_1^2 dt_1 - \int_0^{T/2} t_1^2 dt_1 \right\} \leftarrow t_1 = t - T/2$$



$$= \frac{A}{2} \frac{d^2 \phi_z(t)}{dt^2} \Big|_{t = T/2} \left\{ \int_{-T/2}^0 t_1^2 dt_1 + \int_0^{-T/2} t_2^2 dt_2 \right\} \leftarrow t_2 = -t_1$$

$$= \frac{A}{2} \frac{d^2 \phi_z(t)}{dt^2} \Big|_{t = T/2} \left\{ \int_{-T/2}^0 t_1^2 dt_1 - \int_{-T/2}^0 t_2^2 dt_2 \right\}$$

= 0

= 0

(4.9)

As expected, for the assumed acceleration profile the third term of the Taylor series integrates to zero. The actual acceleration profile will not be precisely as given in (4.7). However, in order for the vehicle to execute a stop-motion-stop process the actual acceleration profile will be similar to (4.7) representing an odd function about the midpoint. For any odd function, the third term of the Taylor series will, therefore, integrate to near zero. Thus, keeping only the first two terms of the Taylor series we have, for any acceleration profile $a(t)$,

$$\int_0^T a(t) \phi_z(t) dt$$

$$= \int_0^T a(t) \left\{ \phi_z(t) \Big|_{t = T/2} + \frac{d\phi_z(t)}{dt} \Big|_{t = T/2} (t - T/2) \right\} dt$$



$$\begin{aligned}
 &= \phi_z(t) \Big|_{t=T/2} \int_0^T a(t) dt + \frac{d\phi_z(t)}{dt} \Big|_{t=T/2} \int_0^T a(t) (t - T/2) dt \\
 &= \phi_z(t) \Big|_{t=T/2} \int_0^T a(t) dt + \frac{d\phi_z(t)}{dt} \Big|_{t=T/2} \left\{ \int_0^T a(t) t dt - \frac{T}{2} \int_0^T a(t) dt \right\} \\
 &= \left\{ \phi_z(t) \Big|_{t=T/2} - \frac{T}{2} \frac{d\phi_z(t)}{dt} \Big|_{t=T/2} \right\} \int_0^T a(t) dt + \frac{d\phi_z(t)}{dt} \Big|_{t=T/2} \int_0^T a(t) t dt \\
 &= \left\{ \phi_z(t) \Big|_{t=T/2} - \frac{T}{2} \frac{d\phi_z(t)}{dt} \Big|_{t=T/2} \right\} \int_0^T \frac{dv(t)}{dt} dt + \frac{d\phi_z(t)}{dt} \Big|_{t=T/2} \int_0^T \frac{dv(t)}{dt} t dt \\
 &= \left\{ \phi_z(t) \Big|_{t=T/2} - \frac{T}{2} \frac{d\phi_z(t)}{dt} \Big|_{t=T/2} \right\} v(t) \Big|_0^T + \frac{d\phi_z(t)}{dt} \Big|_{t=T/2} \left\{ v(t)t \Big|_0^T - \int_0^T v(t) \frac{dt}{dt} dt \right\} \\
 &\hspace{15em} \text{integration by parts} \\
 &= \left\{ \phi_z(t) \Big|_{t=T/2} - \frac{T}{2} \frac{d\phi_z(t)}{dt} \Big|_{t=T/2} \right\} \left\{ \underbrace{v(T)}_{=0} - \underbrace{v(0)}_{=0} \right\} + \frac{d\phi_z(t)}{dt} \Big|_{t=T/2} \left\{ \underbrace{(v(T)T - v(0))}_{=0} - \int_0^T \frac{dv}{dt} dt \right\} \\
 &\hspace{15em} \text{Stop Period begin \& end velocities} \\
 &= - \frac{d\phi_z(t)}{dt} \Big|_{t=T/2} \left\{ P(t) - P(0) \right\} \tag{4.10}
 \end{aligned}$$



Hence, using (4.10) we have for (4.5) and (4.6) respectively

$$\delta V_N = + (E(T) - E(0)) \left. \frac{d\phi_z}{dt} \right|_{t = T/2}$$

$$\delta V_E = - (N(T) - N(0)) \left. \frac{d\phi_z}{dt} \right|_{t = T/2}$$

where

$E(0), E(T)$ - East position of the vehicle at the beginning and end of the motion period

$N(0), N(T)$ - North position of the vehicle at the beginning and end of the motion period



To evaluate $\left. \frac{d\phi_z}{dt} \right|_{t=T/2}$ utilize (3.14) for $i=4$ such that

$$\begin{aligned}\phi_z(t) &= y_{i=4}(t) \\ &= \sum_{j=1}^6 M(4,j) e^{\lambda_j t} \sum_{k=1}^6 M^{-1}(j,k) y_0(k) \\ &+ \sum_{j=1}^6 M(4,j) \frac{1}{\lambda_j} (e^{\lambda_j t} - 1) \sum_{k=1}^6 M^{-1}(j,k) b_0(k) \quad (4.13)\end{aligned}$$

Therefore,

$$\begin{aligned}\left. \frac{d\phi_z}{dt} \right|_{t=T/2} &= \sum_{j=1}^6 M(4,j) \left. \frac{d}{dt} (e^{\lambda_j t}) \right|_{t=T/2} \sum_{k=1}^6 M^{-1}(j,k) y_0(k) \\ &+ \sum_{j=1}^6 M(4,j) \frac{1}{\lambda_j} \left. \frac{d}{dt} (e^{\lambda_j t} - 1) \right|_{t=T/2} \sum_{k=1}^6 M^{-1}(j,k) b_0(k) \\ &= \sum_{j=1}^6 M(4,j) \lambda_j e^{\lambda_j T/2} \sum_{k=1}^6 M^{-1}(j,k) y_0(k) \\ &+ \sum_{j=1}^6 M(4,j) e^{\lambda_j T/2} \sum_{k=1}^6 M^{-1}(j,k) b_0(k) \quad (4.14)\end{aligned}$$



The perturbation solution for motion periods affects only δV_N and δV_E and can, therefore, be written as

$$\begin{aligned} \delta y_i(t) = & \delta P_i \left\{ \sum_{j=1}^6 M(4,j) \lambda_j e^{\lambda_j T/2} \sum_{k=1}^6 M^{-1}(j,k) y_0(k) \right. \\ & \left. + \sum_{j=1}^6 M(4,j) e^{\lambda_j T/2} \sum_{k=1}^6 M^{-1}(j,k) b_0(k) \right\} \end{aligned} \quad (4.15)$$

where

$$\delta P_i = \begin{cases} 0 & i \neq 1, 2 \\ (E(T) - E(0)) & i = 1 \\ -(N(T) - N(0)) & i = 2 \end{cases} \quad (4.16)$$

The total solution during motion periods, $y_i^m(t)$ is given by

$$y_i^m(t) = y_i(t) + \delta y_i(t) \quad (4.17)$$

where $y_i(t)$ is as per (3.15) and $\delta y_i(t)$ as per (4.15).



Hence

$$y(t) = \underbrace{\left\{ \sum_{j=1}^6 M(i,j) e^{\lambda_j t} \sum_{k=1}^6 M^{-1}(j,k) + \delta P_i \sum_{j=1}^6 M(4,j) \lambda_j e^{\lambda_j T/2} \sum_{k=1}^6 M^{-1}(j,k) \right\}}_{T_m} y_0(k)$$

$$+ \underbrace{\left\{ \sum_{j=1}^6 M(i,j) \frac{1}{\lambda_j} (e^{\lambda_j t} - 1) \sum_{k=1}^6 M^{-1}(j,k) + \delta P_i \sum_{j=1}^6 M(4,j) e^{\lambda_j T/2} \sum_{k=1}^6 M^{-1}(j,k) \right\}}_{\Psi_m} b_0(k) \quad (4.18)$$

$$= T_m y_0 + \Psi_m b_0 \quad (4.19)$$

4.3 KALMAN FILTER UPDATING

The real-time software is assumed to have a Kalman filter which periodically updates its states using null velocity measurements during vehicle stop periods. The Kalman filter states in the real-time software are not necessarily the same as those selected here as initial conditions y or the system drivers b . Thus, let the Kalman filter states be represented as vector z different from y or b . But let

$$y = Fz \quad (4.20)$$

and

$$b = Gz \quad (4.21)$$

USE OR DISCLOSURE OF DOCUMENT DATA IS SUBJECT TO THE RESTRICTION ON THE TITLE PAGE OF THIS DOCUMENT.



Then the incremental update for the initial conditions is

$$\Delta y = F\Delta z \quad (4.22)$$

Let K be the Kalman gains, and H the observation matrix of the Kalman filter. Then, the Kalman filter state update increment is given by

$$\Delta z = KHz \quad (4.23)$$

Therefore

$$\begin{aligned} \Delta y &= FKHz \\ &= FKHF^{-1}y \end{aligned} \quad (4.24)$$

Hence, denoting superscript - as prior to update and + as after update,

$$\begin{aligned} y^+ &= y^- - \Delta y \\ &= (I - FKHF^{-1})y^- \end{aligned} \quad (4.25)$$

Thus, the transition matrix for the initial conditions at every update time is

$$\tau_u = (I - FKHF^{-1}) \quad (4.26)$$

Similarly, the transition matrix for the system drivers at every update time is

$$\psi_u = (I - GKHG^{-1}) \quad (4.27)$$



4.4 STOP/MOTION/UPDATING COMBINED

The overall transition matrix T needs to be examined with respect to whether the vehicle is in motion or stationary. Within the stop period the real-time Kalman filter utilizing zero velocity updates also needs to be taken into account. The total vehicle traverse is broken up into multiple legs, each leg includes a stop period and a motion period as shown in figure 4-2. Within the stop period U zero velocity updates of the real-time Kalman filter are performed.

Therefore, the transition matrix from t_0 to t_1 representing a typical leg of the survey traverse is given as

$$\begin{aligned} T(t_1, t_0) = & T_m(t_1, t_{m+1}) T_s(t_{m+1}, t_m^+) T_u(t_m^+, t_m^-) T_s(t_m^-, t_{m-1}^+) \\ & \dots T_u(t_1^+, t_1^-) T_s(t_1^-, t_0) \end{aligned} \quad (4.28)$$

Similarly for Ψ .

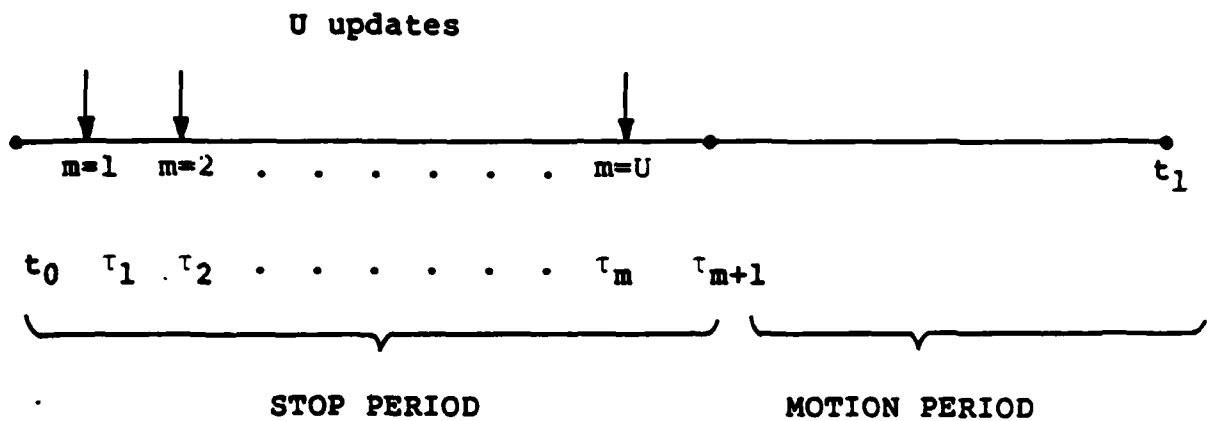

Figure 4-2. Stop/Motion/Updating Periods

76



5.0 OBSERVATION EQUATION

5.1 GENERALIZED FORM AT EACH STOP POINT

The transition equation from time 0 to time t can be generalized for any interval (n-1) to n as

$$y(t_n) = T(t_n, t_{n-1}) y(t_{n-1}) + \psi(t_n, t_{n-1}) b(t_{n-1}) \quad (5.1)$$

or

$$y^n = T^{n-1} y^{n-1} + \psi^{n-1} b^{n-1} \quad (5.2)$$

This can be generalized to

$$\begin{aligned} y^n &= \prod_{i=0}^{n-1} T^i y^0 + \sum_{j=0}^{n-2} \prod_{i=j+1}^{n-1} T^i \psi^j b^j + \psi^{n-1} b^{n-1} \\ &= A^n y^0 + \sum_{j=0}^{n-1} B_j^n b^j \end{aligned} \quad (5.3)$$

where,

$$A^n = \prod_{i=0}^{n-1} T^i \quad (5.4)$$



and

$$B_j^n = \begin{cases} \prod_{i=j+1}^{n-1} \tau^i \psi^j & 0 \leq j \leq n-2 \\ \psi^j & j = n-1 \end{cases} \quad (5.5)$$

Using the notation

$A(i, j) \longrightarrow (i, j)^{\text{th}}$ element of matrix A

$x_k \longrightarrow k^{\text{th}}$ element of vector x

we have

$$y_\ell^n = \sum_{k=1}^6 A^n(\ell, k) y_k^0 + \sum_{j=0}^{n-1} \sum_{k=1}^6 B_j^n(\ell, k) b_k^j, \quad \ell = 1, 2, \dots, 6 \quad (5.6)$$

which represents the value of the ℓ th element of the state vector y at stop time t_n as a function of the initial condition vector elements y_k^0 and the driver at the j^{th} stop vector elements b_k^j .

5.2 LINEAR COMBINATION OF UNKNOWN DEFLECTIONS

The observation equation (5.6) includes the driver

$$b^j = \begin{bmatrix} -g\xi^j & g\eta^j & 0 & \epsilon_Z^j & \epsilon_N^j & \epsilon_E^j \end{bmatrix}^T \quad (5.7)$$



Here, the deflection at each stop point i.e. ξ^j and η^j are expressed as a linear combination of the deflections at all the desired points.

Let there be N spatial points where it is desired to estimate the deflections. Then, the deflections at each stop point can be expressed as a linear combination of the deflections at all the desired points. Thus,

$$\xi^j = \sum_{k=1}^N a_{jk} \bar{\xi}_k + \sum_{k=1}^N b_{jk} \bar{\eta}_k \quad (5.9)$$

$$\eta^j = \sum_{k=1}^N c_{jk} \bar{\xi}_k + \sum_{k=1}^N d_{jk} \bar{\eta}_k \quad (5.10)$$

where

$\bar{\xi}_k, \bar{\eta}_k$ - deflections at the desired points

ξ_j, η_j - deflections at the stop points.

The terms with $\bar{\eta}_k$ in the determination of ξ^j , and vice versa, enter because the deflections are strongly cross correlated.

Defining

$$r_{2j-1} = \xi^j \quad (5.10)$$

$$r_{2j} = \eta^j \quad (5.11)$$

and

$$\bar{r}_{2k-1} = \bar{\xi}_k \quad (5.12)$$

$$\bar{r}_{2k} = \bar{\eta}_k \quad (5.13)$$



we have

$$r_j = \sum_{k=1}^{2N} \alpha_{jk} \bar{r}_k \quad (5.14)$$

which expresses the deflections (odd- ξ , even- η) at the j^{th} stop point, r_j as a linear combination of the deflections (odd- ξ , even- η) at all the desired points, r_k ($1 \leq k \leq 2N$)

Thus,

$$\xi_j = r_{2j-1} = \sum_{k=1}^{2N} \alpha_{2j-1,k} \bar{r}_k \quad (5.15)$$

$$\eta_j = r_{2j} = \sum_{k=1}^{2N} \alpha_{2j,k} \bar{r}_k \quad (5.16)$$

5.3 GYRO DRIFT RATES APPROXIMATED AS CONSTANTS

The gyro drift rates are approximated as constants over the mission. This implies

$$\epsilon_Z^j = \bar{\epsilon}_Z \quad (5.17)$$

$$\epsilon_N^j = \bar{\epsilon}_N \quad (5.18)$$

$$\epsilon_E^j = \bar{\epsilon}_E \quad (5.19)$$

where $\bar{\epsilon}_Z$, $\bar{\epsilon}_N$, $\bar{\epsilon}_E$ are the constant gyro drifts yet to be estimated.

5.4 SEPARATION OF GYRO DRIFT RATES FROM UNKNOWN DEFLECTIONS

Substituting (5.15)-(5.19) in (5.7) yields for any general stop point j

$$\begin{aligned}
 b^j &= \begin{bmatrix} -g\xi^j \\ +gn^j \\ 0 \\ \bar{\epsilon}_Z^j \\ \bar{\epsilon}_N^j \\ \bar{\epsilon}_E^j \end{bmatrix} = \begin{bmatrix} -g \sum_{k=1}^{2N} \alpha_{2j-1,k} \bar{r}_k \\ +g \sum_{k=1}^{2N} \alpha_{2j,k} \bar{r}_k \\ 0 \\ \bar{\epsilon}_Z \\ \bar{\epsilon}_N \\ \bar{\epsilon}_E \end{bmatrix} \\
 &= \begin{bmatrix} 0 \\ 0 \\ 0 \\ \bar{\epsilon}_Z \\ \bar{\epsilon}_N \\ \bar{\epsilon}_E \end{bmatrix} + g \begin{bmatrix} -\alpha_{2j-1,1} & -\alpha_{2j-1,2} & -\alpha_{2j-1,3} & \cdots & -\alpha_{2j-1,2N} \\ \alpha_{2j,1} & \alpha_{2j,2} & \alpha_{2j,3} & \cdots & \alpha_{2j,2N} \\ 0 & & & & 0 \\ & & & 0 & \\ 0 & & & & 0 \end{bmatrix} \begin{bmatrix} \bar{r}_1 \\ \bar{r}_2 \\ \bar{r}_3 \\ \vdots \\ \bar{r}_{2N} \end{bmatrix} \\
 &= C + D_j X \tag{5.20}
 \end{aligned}$$

which separates the unknown constant gyro drift rates C from the unknown deflections X .



Substituting (5.20) in (5.3) yields the final generalized form of the observation equation as

$$y^n = A^n y^0 + \sum_{j=0}^{n-1} B_j^n C + g \sum_{j=0}^{n-1} B_j^n D_j X \quad n = 1, 2, \dots, 6 \quad (5.21)$$

where A^n and B_j^n are given by (5.4) and (5.5) respectively. In the next chapter, methods of estimating y^0 , C , D_j and X are explicitly outlined.



6.0 ESTIMATION METHODS

6.1 INITIAL CONDITION SPECIFICATIONS

At survey traverse initial time $t=0$ the initial deflections are assumed to be known i.e. $\xi(0)$ and $\eta(0)$. Therefore, under consideration of plumbline leveling

$$y_k^0 = \begin{bmatrix} \delta V_N(0) \\ \delta V_E(0) \\ R\delta\phi(0) \\ \phi_Z(0) \\ \phi_N(0) \\ \phi_E(0) \end{bmatrix} = \begin{bmatrix} 0 \\ 0 \\ 0 \\ 0 \\ \eta(0) \\ \xi(0) \end{bmatrix} \quad (6.1)$$

Thus all the elements of y_k^0 in the observation equation are now specified.

6.2 CONSTANT GYRO BIAS ESTIMATION FROM TERMINAL DATA

At the termination of the survey it is assumed that the north-south deflection ($\xi(T)$), east-west deflection ($\eta(T)$) and platform azimuth error ($\phi_Z(T)$) are available.

Thus, at the survey terminal time $t=T$,

$$y_{\ell=4}^n = \phi_Z(T) \quad (6.2)$$

$$y_{\ell=5}^y = \phi_N(T) = \eta(T) \quad (6.3)$$

$$y_{\ell=6}^n = \phi_E(T) = \xi(T) \quad (6.4)$$



But for $4 \leq \ell \leq 6$ the observation equation reduces to

$$y_{\ell}^n = A_{\ell,k}^n y_k^0 + \sum_{j=0}^{n-1} B_{j\ell,k}^n C \quad (6.5)$$

due to the non-coupling of the deflections X into ϕ_Z, ϕ_N, ϕ_E as is evident from the structure of the D_j matrix. These three equations are then solved to obtain the three unknowns in the vector C .

6.3 COEFFICIENT ESTIMATION VIA STATISTICAL COLLOCATION

From (5.14) the relationship that expresses the deflections at the j^{th} stop point as a linear combination of the deflections at the desired points we have as an estimate

$$\hat{r}_j = \sum_{k=1}^{2N} \hat{\alpha}_{jk} \bar{r}_k \quad (6.6)$$

Minimizing the mean square error between r_j and \hat{r}_j leads to

$$\begin{bmatrix} \hat{\alpha}_{1,1} & \hat{\alpha}_{1,2} & \cdots & \hat{\alpha}_{1,2N} \\ \hat{\alpha}_{2,1} & \hat{\alpha}_{2,2} & \cdots & \hat{\alpha}_{2,2N} \\ \hat{\alpha}_{2M,1} & \hat{\alpha}_{2M,2} & \cdots & \hat{\alpha}_{2M,2N} \end{bmatrix} \begin{bmatrix} E(\bar{r}_1 \bar{r}_1) & E(\bar{r}_1 \bar{r}_2) & \cdots & E(\bar{r}_1 \bar{r}_{2N}) \\ E(\bar{r}_2 \bar{r}_1) & E(\bar{r}_2 \bar{r}_2) & \cdots & E(\bar{r}_2 \bar{r}_{2N}) \\ E(\bar{r}_{2N} \bar{r}_1) & E(\bar{r}_{2N} \bar{r}_2) & \cdots & E(\bar{r}_{2N} \bar{r}_{2N}) \end{bmatrix} = \begin{bmatrix} E(r_1 \bar{r}_1) & E(r_1 \bar{r}_2) & \cdots & E(r_1 \bar{r}_{2N}) \\ E(r_2 \bar{r}_1) & E(r_2 \bar{r}_2) & \cdots & E(r_2 \bar{r}_{2N}) \\ E(r_{2M} \bar{r}_1) & E(r_{2M} \bar{r}_2) & \cdots & E(r_{2M} \bar{r}_{2N}) \end{bmatrix} \quad (6.7)$$



or

$$[\hat{g}] [E(\bar{r}\bar{r})] = [E(r\bar{r})] \quad (6.8)$$

where E is the statistical expectation operator

Therefore,

$$[\hat{g}] = [E(r\bar{r})] [E(\bar{r}\bar{r})]^{-1} \quad (6.9)$$

where the needed covariances can be estimated using any one of the many statistical covariance models in practice (Bose and Kouba, 1983). Thus, all the necessary elements of D_j in the observation equation can be estimated.

6.4 LEAST SQUARES ESTIMATION OF DEFLECTIONS

The fundamental observation equation for the least squares estimation of the deflections is given by

$$y^n = A^n y^0 + \sum_{j=0}^{n-1} B_j^n C + g \sum_{j=0}^{n-1} B_j^n D_j X \quad (6.10)$$

where y^0 is known from initial conditions at $t=0$ such that

$$y_k^0 = [0 \quad 0 \quad 0 \quad 0 \quad \eta(0) \quad \xi(0)]^T, \quad (6.11)$$

the vector C given by

$$C = [0 \quad 0 \quad 0 \quad \bar{\epsilon}_Z \quad \bar{\epsilon}_N \quad \bar{\epsilon}_E]^T \quad (6.12)$$



is estimated from terminal conditions $\phi_z(T)$, $\xi(T)$, $\eta(T)$, and the elements of D_j given by

$$D_j = \begin{bmatrix} -\alpha_{2j-1,1} & -\alpha_{2j-1,2} & -\alpha_{2j-1,2} & \dots & -\alpha_{2j-1,2N} \\ \alpha_{2j,1} & \alpha_{2j,2} & \alpha_{2j,3} & \dots & \alpha_{2j,2N} \\ 0 & & & & 0 \\ 0 & & & & 0 \\ 0 & & & & 0 \\ 0 & & & & 0 \end{bmatrix} \quad (6.13)$$

is estimated using statistical least squares collocation as discussed earlier.

Thus the observation equation can be rewritten as

$$y_\ell^n - A^n y^0 - \sum_{j=0}^{n-1} B_j^n C = g \sum_{j=0}^{n-1} B_j^n D_j X \quad (6.14)$$

where

$$y_{\ell=1}^n = \delta V_N^n \quad (6.15)$$

$$y_{\ell=2}^n = \delta V_E^n \quad (6.16)$$

at every stop point ($1 \leq n \leq M$) are the data used in this estimation procedure. The above observation equation can be cast into the form

$$Y = HX \quad (6.17)$$



where

$$Y = y^n - A^n y^0 - \sum_{j=0}^{n-1} B_j^n C \quad (6.18)$$

$$H = g \sum_{j=0}^{n-1} B_j^n D_j X \quad (6.19)$$

The estimate is simply obtained via a least squares solution as

$$X = (H^T H)^{-1} H^T Y \quad (6.20)$$

where

$$X = [\bar{\xi}_1 \quad \bar{\eta}_1 \quad \bar{\xi}_2 \quad \bar{\eta}_2 \quad \dots \quad \bar{\xi}_{2N} \quad \bar{\eta}_{2N}]^T \quad (6.21)$$

are the unknown deflections.

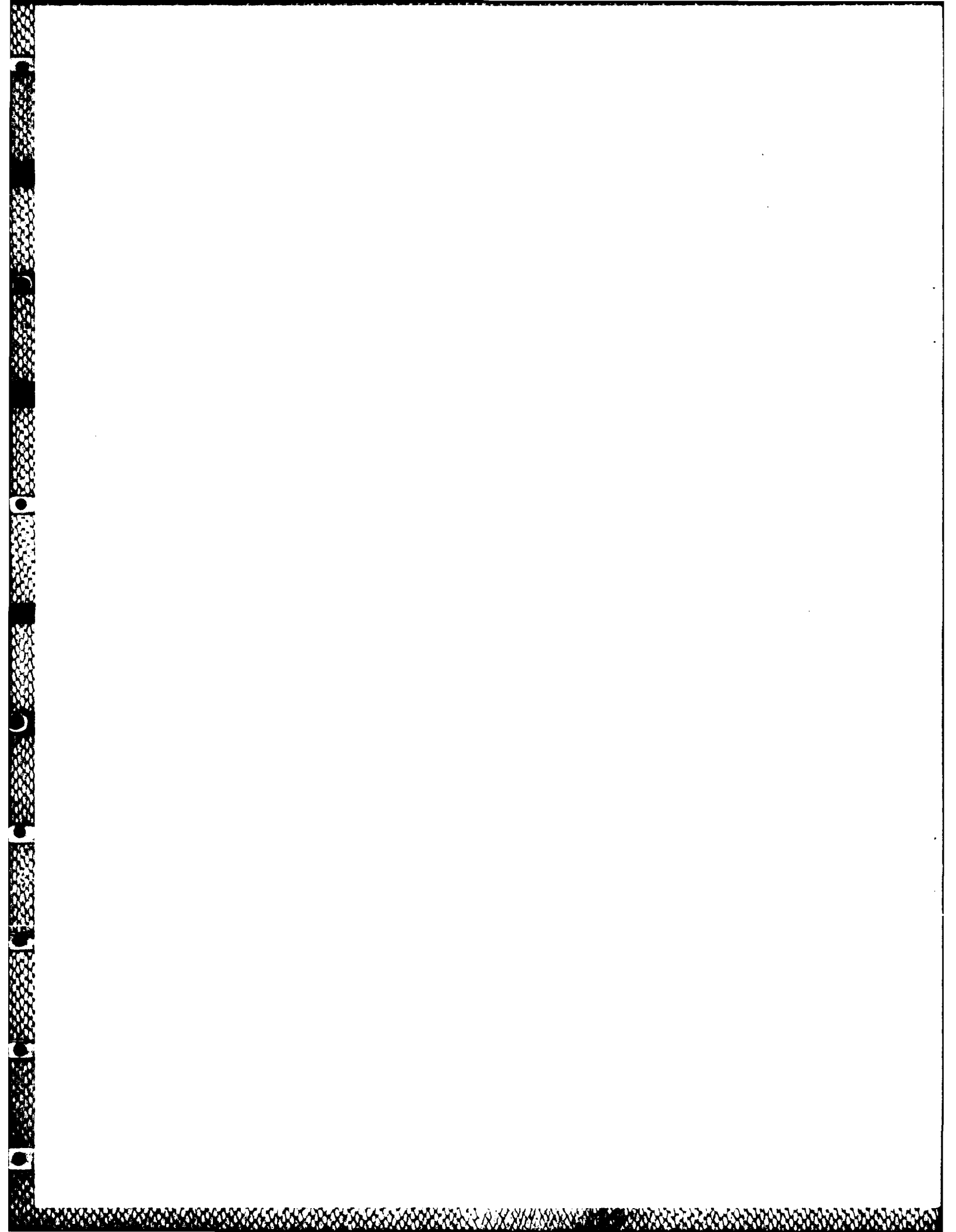



7.0 CONCLUSIONS

7.1 SUMMARY

A new optimal data reduction method for estimating the deflections of the vertical was outlined. Highlights include:

- a. Incorporates dynamical interaction of the two level channels of the inertial system.
- b. Uses existing real-time zero velocity Kalman filter updating during stops along a traverse.
- c. Exploits statistical collocation techniques to preserve correlations between the two components of the deflections of the vertical.
- d. Estimates approximate gyro bias utilizing terminal azimuth and deflection values.
- e. Performs least squares estimation of the unknown deflections utilizing all data simultaneously.

The data necessary to implement the method includes:

- a. Inertial system horizontal velocity errors at each stop.
- b. Inertial system real-time Kalman filter update gains only, no need for real-time covariance data.



- c. Astrogeodetic initial and terminal deflections of the vertical.
- d. Terminal Platform azimuth error observation.

7.2 RECOMMENDATIONS

It is recommended that software be developed to implement the algorithms derived herein. Such a software package will be useful and significant for future vertical deflection determination and densification in support of the Defense Mapping Agency, U.S. Army and U.S. Air Force.



REFERENCES

BAUSSUS VON LUETZOW, H., A New Method for the Determination of Deflections of the Vertical from Astrogeodetic and Inertially Derived Data, Paper, Spring Meeting, Am Geophys. Union, Baltimore, MD, 1981.

BAUSSUS VON LUETZOW, H., Gravity Vector Determination from Inertial and Auxiliary Data and Potential Utilization of Generated Vector Component Information, Proc. Army Science Conference, West Point, NY, 1982.

BAUSSUS VON LUETZOW, H., On Recent Progress in and Utilization of Astrogeodetic-Inertial and Astrogeodetic Gradiometric Gravity Vector Determination. XVII International Congress, Sofia, Bulgaria, paper 611.2, June 19-28, 1983.

BOSE, S.C. and J.T. KOUBA, Gravity Compensation for Inertial Navigation Systems, Part I: Models and Algorithms, Applied Science Analytics, Inc., Technical Report No. ASA-TR-83-1, March 1983.

BROGAN, W.L., Modern Control Theory, Quantum Publishers, Inc., New York, N.Y., 1974.

CLARK, W.J., Final Technical Report on the Application of Inertial Techniques to Surveying, Litton Systems, Inc., Guidance and Control Systems Division, Woodland Hills, California, Rept. AQ22107E66, U.S. Government Contract DA-44-009-AMC-1425(X) for USAEGIMRADA, Fort Belvoir, VA, Nov. 1966.



ELLS, S.R., The Design, Fabrication, and Test of a Position and Azimuth Determining System (PADS) Final Report, Litton Systems, Inc., June 1973.

HUDDLE, J.R. and R.W. MAUGHMER, The Application of Error Control Techniques in the design of an Advanced Augmented Inertial Surveying System, 28th Annual Meeting of the Institute of Navigation, West Point, N.Y., June 1972.

HUDDLE, J.R., A Study of the Position and Azimuth Determining System for Mapping, Charting and Geodesy Applications, U.S. Government Contract DAAK02-73-C-0239 for Research Inst., U.S. Army Engineer Topographic Labs., Aug. 1973.

HUDDLE, J.R. and R.H. LENTZ, Post Mission Smoothing and Analysis of the Measurements of the Change in the Deflection of the Vertical Obtained by the Rapid Geodetic Survey System (RGSS) at the White Sands Test Range, U.S. Government Contract DAAG53-75-C-0248 for Research Inst., U.S. Army Engineer Topographics Labs., Sept 1976.

HUDDLE, J.R., The Measurement of the Change in the Deflection of of the Vertical with a Schuler-Tuned North Slaved Inertial System, Litton Guidance and Control Systems for U.S. Army Engineer Topographic Laboratories, Ft. Belvoir, Virginia, 1977.

HUDDLE, J.R., Theory and Performance for Position and Gravity Survey with an Inertial System, J. of Guidance and Control, 1, 3, 1978.



HUDDLE, J.R., A.J. BROCKSTEIN, R.W. BUCHLER, and S.C. BOSE, A Study to Optimize Performance of the Rapid Geodetic Survey System (RGSS), ETL Reports, April 1981, June 1981a,b, August 1982.

HUDDLE, J.R., Inertial Navigation System Error Model Considerations in Kalman Filter Applications. AGARDograph No. 256, Advances in the Techniques and Technology of the Application of Nonlinear Filters and Kalman Filters, March 1982.

MANCINI, A. and J.R. HUDDLE, Gravimetric and Position Determinations Using Land-Based Inertial Systems, Proceedings of the 35th Annual Meeting of the American Congress on Surveying and Mapping, Washington, D.C., pp. 93-106, March 1975.

MAUGHMER, R.W. and J.R. YAMAMOTO, Final Report Advanced Study of a Position and Azimuth Determining Systems, Litton Systems, Inc., Guidance and Control Systems Division, Woodland Hills, California, Rept. AW51073J68, U.S. Government Contract DAAK02-68-C-0214 for USAETL, Fort Belvoir, VA, Dec. 1968.

MAUGHMER, R.W. and BYRD, D.M., Supplement to Final Report, Advanced Study of a Position and Azimuth Determining System, Litton Systems, Inc., Guidance and Control Systems, Division, Woodland Hills, California, Rept. AQ51073J685, July 1969.

END

FILMED

3

-86

DTIC