

AD-R165 047

AUTOMATED AIDS TO TEST DATA GENERATION(U) ARMY
ELECTRONIC PROVING GROUND FORT HUACHUCA AZ W H KUKES
NOV 85

1/1

UNCLASSIFIED

F/G 9/3

NL

END
FILMED
DTC

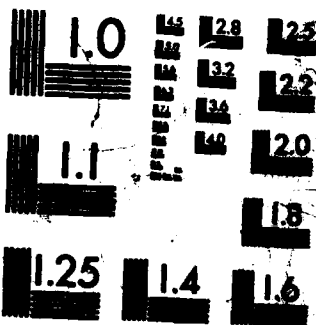

MICROCOPY RESOLUTION TEST CHART
NATIONAL BUREAU OF STANDARDS-1963-A

2

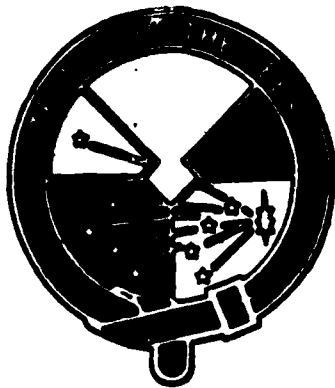

UNCLASSIFIED

DDC AD NUMBER _____

FUNDING PROJECT NO. IT665702D625

TECOM PROJECT (TRMS) NUMBER 7-CO-R85-EPO-008

TEST ACTIVITY REPORT NO. _____

TEST SPONSOR: U.S. ARMY TEST AND
EVALUATION COMMAND

AD-A165 047

DTIC FILE COPY

METHODOLOGY INVESTIGATION

FINAL REPORT

AUTOMATED AIDS TO TEST DATA GENERATION

by

CPT William H. Kukes

November 1985

DTIC
ELECTE
MAR 12 1986
S D
B

U.S. ARMY ELECTRONIC PROVING GROUND

FORT HUACHUCA, ARIZONA

DISTRIBUTION STATEMENT A
Approved for public release
Distribution Unlimited

UNCLASSIFIED

36 3 12 04

DISPOSITION INSTRUCTIONS

Destroy this report in accordance with appropriate regulations when no longer needed. Do not return it to the originator.

DISCLAIMER

Information and data contained in this document are based on input available at the time of preparation. Because the results may be subject to change, this document should not be construed to represent the official position of the U.S. Army Materiel Command unless so stated.

The use of trade names in this report does not constitute an official indorsement or approval of the use of such commercial hardware or software. This report may not be cited for purposes of advertisement.



DEPARTMENT OF THE ARMY
HEADQUARTERS, U.S. ARMY TEST AND EVALUATION COMMAND
ABERDEEN PROVING GROUND, MARYLAND 21005-5000

REPLY TO
ATTENTION OF

AMSTE-TC-M

24 JAN 1986

SUBJECT: Methodology Investigation Final Report, TECOM Project
7-CO-R85-EPO-008

Commander
U.S. Army Electronic Proving Ground
ATTN: STEEP-MT-DA
Fort Huachuca, AZ 85613-7110

1. Subject report is approved.
2. Test for the Best.

FOR THE COMMANDER:

GROVER H. SHELTON
C, Meth Imprv Div
Technology Directorate

UNCLASSIFIED

SECURITY CLASSIFICATION OF THIS PAGE (When Data Entered)

REPORT DOCUMENTATION PAGE		READ INSTRUCTIONS BEFORE COMPLETING FORM
1. REPORT NUMBER TRMS No. 7-CO-R85-EPO-008	2. GOVT ACCESSION NO. AD-A165047	3. RECIPIENT'S CATALOG NUMBER
4. TITLE (and Subtitle) METHODOLOGY INVESTIGATION FINAL-REPORT AUTOMATED AIDS TO TEST DATA GENERATION		5. TYPE OF REPORT & PERIOD COVERED Methodology Investigation Final Report
		6. PERFORMING ORG. REPORT NUMBER
7. AUTHOR(s) CPT William H. Kukes		8. CONTRACT OR GRANT NUMBER(s)
9. PERFORMING ORGANIZATION NAME AND ADDRESS US Army Electronic Proving Ground Fort Huachuca, AZ 35613-7110		10. PROGRAM ELEMENT, PROJECT, TASK AREA & WORK UNIT NUMBERS IT665702D625
11. CONTROLLING OFFICE NAME AND ADDRESS US Army Test and Evaluation Command Attn; AMSTE-TC-M Aberdeen Proving Ground, MD 21005-5055		12. REPORT DATE Nov 1985
		13. NUMBER OF PAGES 41
14. MONITORING AGENCY NAME & ADDRESS (if different from Controlling Office)		15. SECURITY CLASS. (of this report) Unclassified
		15a. DECLASSIFICATION/DOWNGRADING SCHEDULE
16. DISTRIBUTION STATEMENT (of this Report) Approved for public release; distribution unlimited.		
17. DISTRIBUTION STATEMENT (of the abstract entered in Block 20, if different from Report)		
18. SUPPLEMENTARY NOTES		
19. KEY WORDS (Continue on reverse side if necessary and identify by block number) Scenario Development Test Item Stimulator Test Message Data Base Automated Message Generation		
20. ABSTRACT (Continue on reverse side if necessary and identify by block number) The Automated Aids to Test Data Generation Methodology Investigation examined existing scenario development procedures of the Test Item Stimulator, identifying processes amendable to automation. Based on the test message processing requirements of the identified processes, an automated message generation tool was developed.		

TABLE OF CONTENTS

	<u>Page</u>
FOREWORD.....	v

SECTION 1. SUMMARY

Paragraph
Number

1.1	Background.....	1
1.2	Objective.....	1
1.3	Summary of Procedures.....	1
1.4	Summary of Results.....	1
1.5	Analysis.....	2
1.6	Conclusions.....	2
1.7	Recommendations.....	2

SECTION 2. DETAILS OF INVESTIGATION

2.1	Identification of Processes Amenable to Automation.....	3
2.2	Automated Test Message Processing Requirements.....	3
2.2.1	Message Retrieval.....	3
2.2.2	Message Processing.....	4
2.2.3	Utilization of External Files.....	4
2.2.4	Review and Modification of Results.....	5
2.3	Automated Message Generation Function.....	5
2.3.1	Overview.....	5
2.3.2	Generators.....	8
2.3.3	Transaction File Review, Modification, and Committing.....	10
2.4	Automated Message Generation Function Implementation.....	12
2.4.1	Generator Index.....	13
2.4.2	Transaction File Index.....	17
2.4.3	Modifier Index.....	17

SECTION 3. APPENDIXES

A.	Methodology Investigation Proposal.....	19
B.	Acronyms.....	25
C.	Test Item Stimulator Overview.....	29
D.	Distribution.....	37

LIST OF FIGURES

<u>Figure</u>		<u>Page</u>
1	Automated Message Generation Data Flow.....	6
2	Pre-test Screen Hierarchy.....	14
3	Automated Message Generation Screen Hierarchy.....	15
C-1	Test Item Stimulator Data Flow.....	32
C-2	Test Message Data Base Subschema.....	33



Accession For	
NTIS GRA&I	<input checked="" type="checkbox"/>
DTIC TAB	<input type="checkbox"/>
Unannounced	<input type="checkbox"/>
Justification	
By	
Distribution/	
Availability Codes	
Dist	Avail and/or Special
A-1	

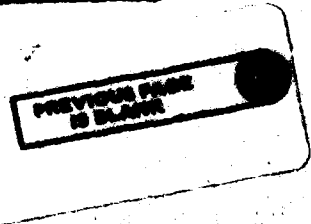

FOREWORD

Ultrasystems Technology Incorporated, Sierra Vista, Arizona
assisted in the preparation of this document under
Contract Number DAEA18-83-C-0003

1. SUMMARY

1.1 Background

The Test Item Stimulator (TIS) was developed by the U.S. Army Electronic Proving Ground (USAEPG) for the developmental and interoperability testing of automated command, control, communication, and intelligence (C³I) systems. By definition, interoperability testing requires the testing of multiple systems that communicate through the exchange of digital messages, verifying that these systems meet their performance requirements. Since test scenarios may contain thousands of messages, an efficient, automated method is required to enhance those test message composition and manipulation capabilities in the TIS.

1.2 Objective

→ The Automated Aids to Test Data Generation investigation was initiated to provide a method for automating the composition and validation of scenarios used in the developmental testing of message-driven systems.

1.3 Summary of Procedures

→ Existing scenario development software and procedures were examined to identify processes amenable to automation. From those identified, specific processes were selected for further study. Functional requirements were then developed and an Automated Message Generation (AMG) tool was designed. Subsequent project effort focused on the implementation of this tool. →

1.4 Summary of Results

a. Five general categories of scenario development processes were identified as being amenable to automation: message format definition, message generation, scenario modification, scenario validation, and the conversion of non-TIS scenarios. Of these processes, message generation, scenario modification, and non-TIS scenario conversion were selected for automation.

b. A common set of functional requirements for the selected processes were developed: sets of messages need to be retrieved, modified, and then copied or replaced; processing parameters and message data should be optionally input from an external file (e.g., non-TIS scenario); and there should be some mechanism for reviewing and correcting the results of this automated processing, prior to committing any changes to the test message data base.

c. The AMG tool was designed to meet these requirements. This tool produces files of data base transactions, which may then be reviewed, modified, and committed to the data base (resulting in the generation, modification, or deletion of test messages). As an option, parameters and message data for the transaction generation phase of processing may be supplied by an external file.

d. The effort to implement the AMG tool resulted in the development of the transaction file generation, transaction file review, and transaction file commit functions, as well as the operator interface screens.

1.5 Analysis

An analysis of existing scenario development procedures indicated that additional generation, modification, and conversion processes were amenable to automation. The identified generation, modification, and conversion requirements were met through the design of a single tool for processing test messages. The validation of this tool would require that it be used during the testing of a tactical system.

1.6 Conclusions

f p. 1
→ The application of the AMG tool to *Test Item Stimulator* (GIS) scenario development processes would serve to validate the AMG design. In addition, the application of this tool to the development of tactically significant scenarios would result in the refinement of the AMG design and the identification of additional processes amenable to automation.

1.7 Recommendations

← The AMG effort should be continued, to demonstrate an increased capability to generate large, coordinated test message scenarios. The results of applying this tool to the system-level testing of message-driven systems may indicate that this tool should be further refined and integrated into the TIS.

2. DETAILS OF INVESTIGATION

The following sections detail the investigation of scenario development processes amenable to automation, the development of requirements for functions to be automated, the design of the AMG tool, and its implementation. An overview of the TIS and its test message data base is provided as appendix C.

2.1 Identification of Processes Amenable to Automation

The scenario development software of the TIS was examined, and scenario developers using the TIS were interviewed in an effort to identify test message generation processes that could be automated. The following labor-intensive areas were identified:

a. Message format definition. Before a message can be used as an event component, its field structure must be defined. Since developmental testing may involve testing with several types of message formats, a large amount of effort may be involved, using current procedures. It would, therefore, be highly desirable to add the capability of accepting machine-readable format definitions from various sources. Adding this capability was not, however, further investigated, due to the complexity of the format definition process and the expected variety in the format definition inputs.

b. Message generation. Since test scenarios contain a large number of messages and their transmission times and content typically have well defined relationships with mathematical models, a variety of test message generation processes are potentially amenable to automation.

c. Scenario modification. Once a scenario has been developed, testing requirements may change; thus, the capability of changing transmission times and data fields in mass would be desirable.

d. Scenario validation. A need for static scenario validation tools was identified; however, a further examination of TIS software revealed a number of useful data reduction and analysis tools already existing in post-test, that were capable of processing scenario files directly.

e. Conversion of non-TIS scenarios. Automating the input of test messages into the TIS data base from non-TIS scenario files would reduce the data entry efforts currently required to manually generate these scenarios.

2.2 Automated Test Message Processing Requirements

The message generation, scenario modification, and non-TIS scenario loading processes were further investigated. A common set of automated processing requirements were identified.

2.2.1 Message Retrieval

When generating new messages, it is desirable to use an existing message as a template, modifying only those fields that differ from message-to-message. Also, a retrieval of target messages insures that messages to be replaced or deleted are in the data base. Thus, the retrieval of messages is common to the processes to be automated. The following retrieval requirements were identified:

- Any existing message should be available for use as a template.
- Message retrieval should be based on the values of key fields, control fields, or data fields.
- Message retrieval, based on occurrence in a specific scenario, should be allowed.
- Single message or multiple message retrieval should be allowed.
- The processing order of a multiple message retrieval should be selectable.
- The retrieval of messages of different types and from more than one event should be allowed.

2.2.2 Message Processing

Automating message processing requirements were found to be complex and application-specific. However, a number of features were identified that, when combined, would allow for the automation of a wide variety of complex applications:

- In addition to specifying field values through constant parameters, these values should be generated using algorithmic processes. The capability of specifying a sequence of mathematical or string functions, operating on control and data fields, was found to be desirable.
- The generation of field values should be based on the values of constants, one or more fields of the current message or the previous message, random values, or temporary variables.
- Certain control fields should not be modified. In addition, a mechanism must be provided for the validation of fields that are modified.
- Although the modification of messages in events used to define one scenario could lead to the inadvertent modification of other scenarios, the modification of these messages should be allowed, if explicitly requested.
- A conditional processing mechanism would be required for data generation applications that are not readily specified using an algorithmic or functional approach.

2.2.3 Utilization of External Files

In some cases, this message selection and processing would be most conveniently specified by a single set of parameters; while in other cases, message selection and processing would be more appropriately specified by a file of records containing these parameters. The use of external files to supply control and data information would provide the basic mechanism for loading non-TIS scenarios. To utilize a wide variety of inputs and to provide flexibility, there should be a mechanism for defining the field structure of a particular file and for specifying any processing needed prior to using data from these fields.

2.2.4 Review and Modification of Results

The results of any automated processing should be available for review and correction prior to committing them to the test message data base. The message data should be presented in a character format, and only those fields that are affected by processing should be displayed. A processing mechanism, similar to that described for modifying retrieved messages, should be provided to allow corrections prior to committing changes to the data base.

2.3 Automated Message Generation Function

Based on the automation requirements identified, an AMG tool was designed to be run as a stand-alone system or as a sub-function of the TIS pre-test.

2.3.1 Overview

The AMG function generates files of data base transactions, called tranfiles, and uses these files to create, modify, and delete data base messages. The AMG function also generates tranfile listings and allows the modification and reuse of these files. An external file, called a driver file, can be used to control tranfile generation. Figure 1 depicts the data flow of the AMG function.

2.3.1.1 Transaction File Generation

Tranfiles are generated using operator-defined tools called generators. Generators retrieve messages from the data base, process the control and data fields of these messages, and generate tranfile records that are later used to append, replace, or delete messages. Generator processing parameters may be initialized by the operator or may be specified by a driver file. Generator definitions are stored in the data base and may be reused.

2.3.1.2 Transaction File Review and Modification Prior to Commit

Tranfiles may be reviewed and modified, prior to committing their transactions to the data base. Tranfile records may be examined, modified, and written into a second tranfile, using operator-defined tools called modifiers. Like generators, modifiers are stored in the data base and may be reused. Tranfile listings are available for manual review.

2.3.1.3 Specification of Processing Options

At certain points during generator and modifier processing, operator-defined sequences of instructions are processed. These instructions, called actions, allow application-specific message processing by affecting internal generator and modifier variables.

2.3.1.3.1 Action Blocks

Action blocks are lists of operator-specified actions to be invoked at specific points during modifier and generator processing. Generators have three action blocks:

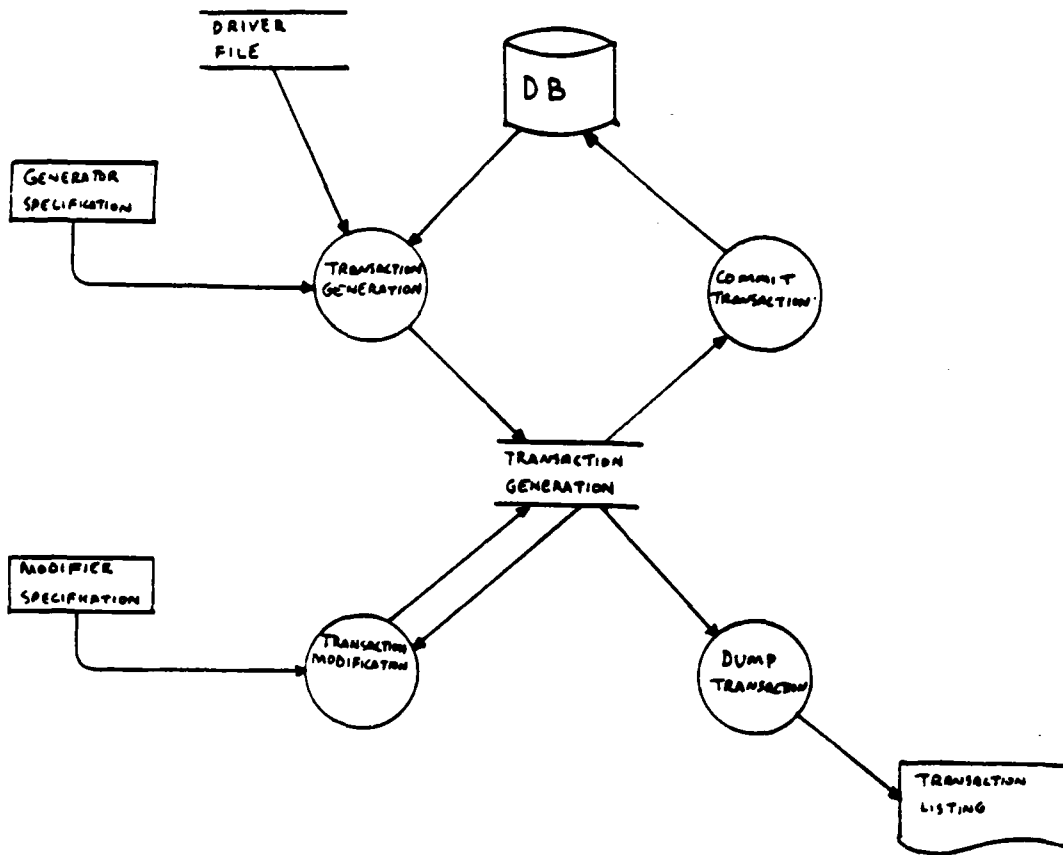

Figure 1. Automated Message Generation Data Flow

- Initialization actions. These actions are invoked one time, at the beginning of tranfile generation.

- Record actions. These actions are invoked each time a driver file record is input.

- Message actions. These actions are invoked each time a message (segment) is retrieved.

Modifiers have two action blocks:

- Initialization actions. These actions are invoked at the beginning of tranfile modification.

- Tranfile record actions. These actions are invoked each time a tranfile record is input.

2.3.1.3.2 Actions and Variables

a. Actions are used to modify internal variables and control generator or modifier processing. They are specified by adding an action line to the appropriate action block. Action lines consist of an action keyword and a list of qualifying parameters which identify the specific variables affected or other processing options.

b. Actions fall into the following general categories:

- Data movement. These actions are used to move data between message fields and other internal variables.

- String and mathematical functions. These actions are used to generate and manipulate data.

- Control. These actions are used to provide conditional processing and interrupt or change normal processing.

- Transaction generation. These actions are used to generate transaction records.

c. Internal variables can be accessed and modified by referencing them in action parameter lists. These following types of information are accessible as variables:

- Event Composition record fields. Message key fields and control fields are stored in variables. The Message Type and Message Index fields are read-only type variables.

- Field Data record fields. These fields are accessible only through special data movement actions that move them to and from variables.

- Driver file record fields. Driver file record fields are loaded into variables according to a specified format definition.

● Tranfile record fields. During tranfile generation, tranfile records are generated, using data from specific variables. During tranfile modification, these same variables are loaded from tranfile records of the original tranfile and, after tranfile record action processing, they are used to generate tranfile records in the new tranfile.

● Processing status. Generator and modifier status variables are updated during processing.

● In addition, to these variables, general purpose variables are available for temporary storage of information: character strings (up to 100 characters long), integers, and floating point numbers.

d. Specific details on actions and variables are detailed in the AMG Operator Manual.

2.3.2 Generators

Tranfile generators retrieve messages, modify message fields, and generate data base transactions. Message retrieval is specified using a retrieval qualification expression which selects a group of messages. In addition, single and multiple message retrievals may be specified. A generator may be set up to operate in a one-pass mode or in a file-driven mode, where generator processing is invoked once per driver file record.

2.3.2.1 Generator Initialization Actions

The first step of generator processing is the interpretation of any initialization actions specified. If any initialization actions errors occur, generator processing is terminated.

2.3.2.2 Driver File Processing

a. If a generator is file-driven, driver file records are read, one at a time, and processed. Records are read into a buffer and then moved into variables, according to a record field definition called a format. Record actions are then interpreted prior to message retrieval processing. If a generator is not file-driven, message retrieval processing immediately follows initialization actions.

b. The movement of data from driver file record fields into variables is controlled by operator-defined formats. Formats contain a list of field definitions that specify the start column and length of the field to move and the destination variable.

c. After record fields are moved any specified record actions are invoked. If any errors occur during the data movement or record actions processing, an error transaction is generated, message retrieval processing is skipped, and processing continues with the reading of the next driver file record.

2.3.2.3 Message Retrieval Processing

a. During message retrieval processing, messages are retrieved from the TIS test message data base, with the message selection specified by a retrieval qualification expression. Each of the messages retrieved is then processed by invoking the actions in the message actions block.

b. The following options are available for controlling the processing of the retrieved messages:

- Single message retrieval. This option results in the processing of only one message.

- Multiple retrieval, unsorted. This option results in the processing of all messages meeting the retrieval qualification requirements in the order they were retrieved from the data base (this order is not necessarily the order that messages were added to the data base). This option speeds up processing, since no sorting is required.

- Multiple retrieval, sorted. This option results in the processing of messages in ascending order of System ID, Event ID, Message Delta Time, and Segment Number. Thus, segments are grouped together, messages are grouped within events, and events within systems.

2.3.2.4 Retrieval Qualification

a. Operator-defined retrieval qualification expressions specify ranges of values that fields of data base messages are compared against. These expressions have the same syntax as INGRES where clauses, with an additional feature allowing the substitution of internal variables for constants. Thus, driver file fields can be read into variables and used to select messages to be processed.

b. In the case where no messages in the data base meet the retrieval qualification constraints, an error transaction is generated, no message actions processing occurs, and, if the generator is file-driven, processing continues with the reading of the next driver file record.

2.3.2.5 Message Processing

Each message retrieved is processed by invoking the operator-defined message actions. The key and control fields of the current message segment are accessible as variables that can be modified by numeric and string processing actions. The data fields (Field Data records) can be retrieved and modified, using special data movement actions. Field values can be checked, using conditional processing actions. After control and data field modification, transaction generating actions are used to append, replace, or delete the current message.

2.3.2.6 Transaction Generation

a. Two types of data base transaction records are generated when new messages are appended to the data base:

● Message copy. This type of transaction, when committed to the data base, results in the creation of a new Event Composition record and a set of Field Data records. The Event Composition fields are supplied by the transaction record (modified template message), except for the Message Index, which is allocated during commit processing. The Field Data records are copied directly from the template message, using the original Message Index.

● Field Replace. This type of transaction, when committed to the data base, results in the replacement of the Data field of a Field Data record. One transaction record, of this type, is generated for each data field that is modified, prior to a Message Append (and Replace). This transaction must be preceded by either a Message Copy or a Message Replace transaction, since those transactions set up the current Message Index.

b. Two types of transaction records are generated when existing messages are modified:

● Message replace. This transaction, when committed to the data base, results in the modification of an Event Composition record. This type of transaction record contains two sets of key fields: the original retrieved key fields (which specify the record to be modified) and the modified key fields (which may have been modified during message processing).

● Field replace. This is the same type of transaction used to append new messages (in both message appending and message replacement, Field Replace transactions are applied to the field of the current message, whether they have been copied by a Message Copy or specified by a Message Replace).

c. Message delete transactions are generated in order to delete a message. This transaction, when committed to the data base, results in the deletion of the specified Event Composition record and all Field Data records associated with it, through its Message Index.

d. Error transactions are generated to signal special or unusual conditions. Although these transactions appear in listings, they do not have any effect on the data base when committed.

2.3.3 Transaction File Review, Modification, and Committing

Tranfile listings may be generated for review, prior to committing tranfiles. If any changes are required, a tranfile can be processed sequentially, resulting in the generation of another tranfile. When tranfiles are committed to the data base, a number of checks are made to insure that the changes do not adversely affect other test message data base users.

2.3.3.1 Transaction File Listing

Tranfile listings display the transaction record fields:

● Transaction number. This field is present in all tranfile records. This number indicates the order that the records were generated, which would otherwise be lost if the tranfile were sorted.

- Key fields. These fields are the Event Composition key fields for Message Copy, Field Replace, and Message Delete transactions. These fields are the new key field values for Message Replace transactions. These fields are not found in error and warning type transactions.

- Message type. This field is found in all data base type transactions.

- Transaction type. This field is found in all tranfile records.

- Field #. This field is found in data base type transactions. It has a value of zero, if it is a Message Copy, Message Replace, or a Message Delete. It contains the Field #, if it is a Field Replace type transaction.

- Override flag. This field appears in data base type transactions, except for the Field Replace. This flag is used to bypass scenario modification checking.

- Control fields. These fields appear in data base transactions, except for the Field Replace. Message Replace transactions also include the original key fields.

- Field data. Field Replace transactions have this field, which contains message field data.

- Text. Error transactions contain text fields.

2.3.3.2 Transaction File Modification

Modifiers sort and then sequentially process tranfiles, producing other tranfiles (the original tranfile is not changed). Like generator processing, modifier processing can be controlled through operator-specified actions. Modifiers can be used to:

- Detect and correct error conditions.

- Change delta times (allowing reordering and resequencing).

- Generate several similar transaction files from an original.

2.3.3.2.1 Sorting and Filtering

a. Prior to sequential processing, an optional sort is performed. The following options are available:

- Sort by transaction number. This option causes the tranfile records to be processed in the same order they were generated.

- Sort by key. This option groups fields within segments, segments within messages, messages within events, and events within systems.

- No sort. The tranfile is processed without first sorting.

b. Specific types of transactions can be selected for processing. The following filtering options are available:

- All transactions. Data base and error transactions are processed.
- Data base transactions only. Message Copy, Message Replace, Field Replace, and Message Delete transactions are processed.
- Error only. Error transactions are processed.
- No processing. This option sorts the tranfile, producing a new tranfile, without further processing.

2.3.3.2 Transaction Record Modification

a. Prior to sequential tranfile record processing, operator-specified initialization actions are processed. If any errors occur during initialization action processing, modifier processing stops.

b. Tranfile records are read and processed, one at a time. The various tranfile record fields are read into variables, where they may be accessed through tranfile record actions. The old key fields, message index, and message type fields cannot be modified. Unless otherwise specified, each tranfile record is written to the new tranfile, after tranfile record actions processing.

2.3.3.3 Committing Data Base Transactions

Tranfiles are committed to the TIS data base by sequentially applying tranfile records. Any error conditions result in the generation of a commit error log tranfile, containing error messages. When an error occurs during the processing of a tranfile record, an error transaction is generated and processing continues with the next record. The following error conditions can occur:

- Modification of scenario components. Since events are used to build scenarios, the modification of an event in one scenario can result in the inadvertent modification of other scenarios. Message Copy, Message Replace, and Message Delete transactions have an Override Flag, which indicates whether or not these transactions can be applied if their Event ID fields are found in any Scenario Composition records.
- Uniqueness. Message copy transaction key fields must not match an existing message. Otherwise, this transaction could inadvertently replace an existing message.
- Missing message. The Message Replace and Message Delete transaction key fields must reference an existing message.

2.4 Automated Message Generation Function Implementation

a. The effort to implement the AMG function resulted in the development of an operator interface, a file-driven generator function, and tranfile listing, modification, and commit functions.

b. A high-level, menu-driven interface to the AMG functions was developed. This interface was designed to be included as a sub-function to the Event Definition Index function of the TIS pre-test (see figure 2), or to be run as a stand-alone tool.

c. The AMG Menu screen is used to select one of the three main areas of AMG processing:

- Generators. This area includes the definition and application of tranfile generators (control passed to the Generator Index screen).

- Tranfiles. This area includes the listing, committing, and deletion of tranfiles (control passed to the Transaction File Index screen).

- Modifiers. This area includes the definition and application of tranfile modifiers (control passed to the Modifier Index screen).

d. The following sections detail the operator interface to the AMG functions (see figure 3). Additional details can be found in the AMG Operator Manual.

2.4.1 Generator Index

This screen displays a list of existing tranfile generators and provides access to the following functions:

- Create. This function creates a new generator, with default processing options specified. Control is passed to the Generator Specification screen, where this new generator can then be tailored to a specific application.

- Specify. This function retrieves an existing generator, allowing the processing options of this generator to be changed (Generator Specification).

- Delete. This function deletes an existing generator.

- Generate. This function generates a tranfile, using the specified processing options.

- List. This function generates a hard-copy listing of a generator's processing options.

2.4.1.1 Generator Specification

The Generator Specification screen is used to view and modify the processing options of a generator. The following functions are accessed through this screen:

- INIT. This function passes control to the Initialization Actions screen.

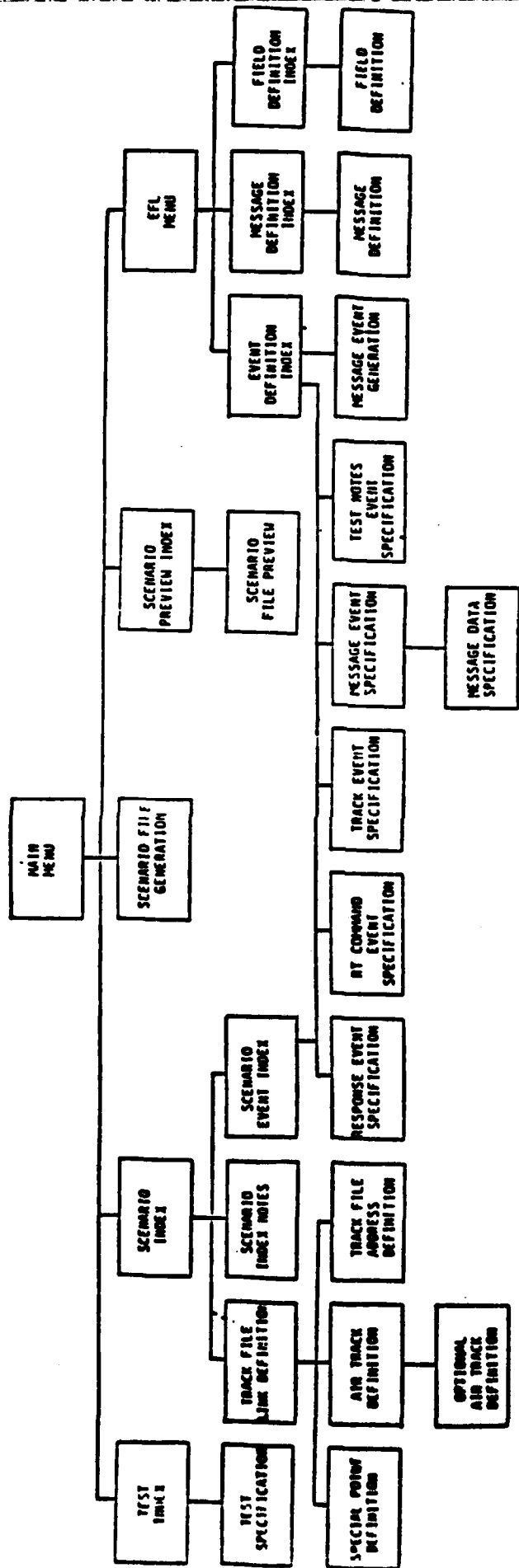

Figure 2. Pre-test Screen Heirarchy

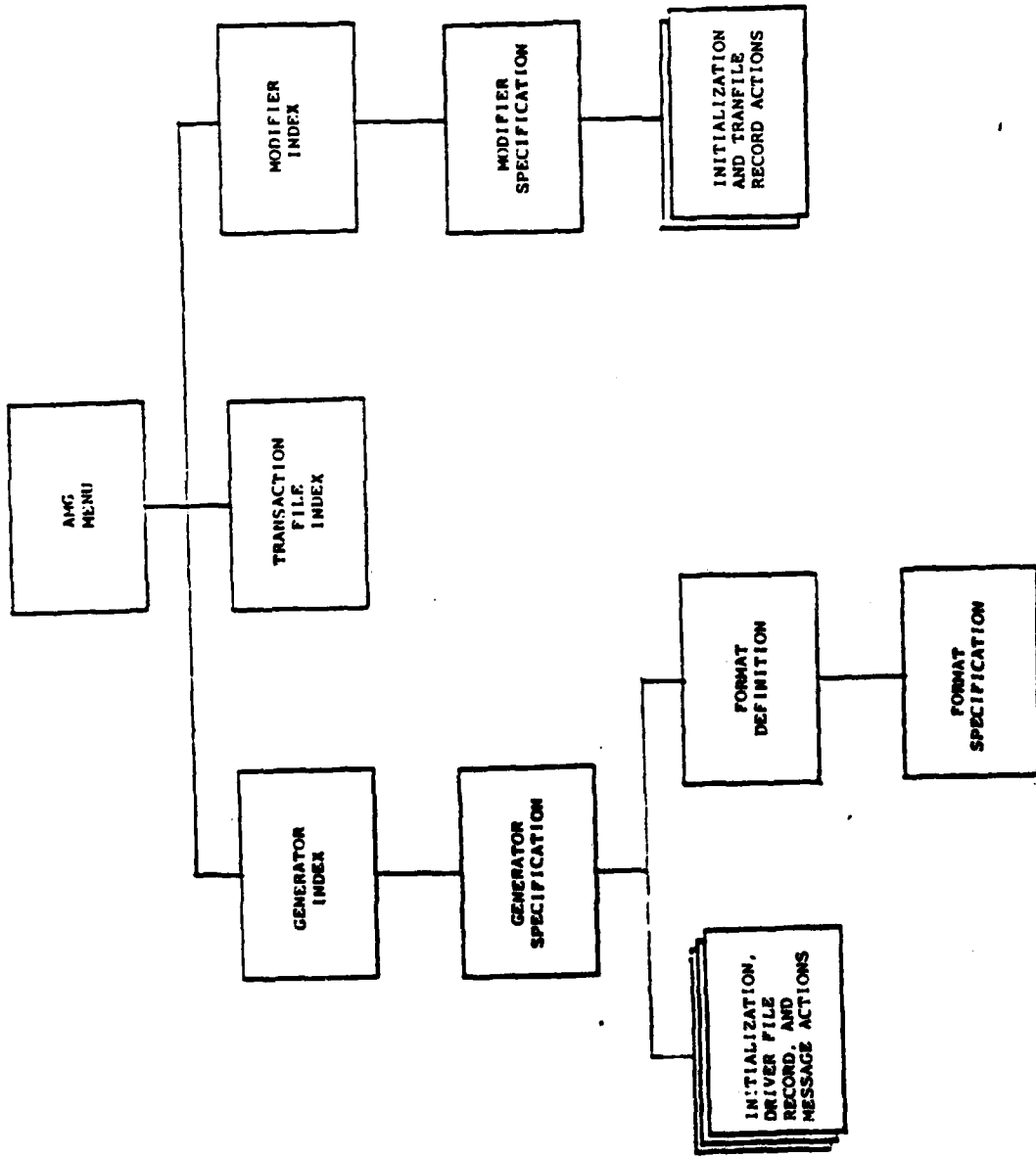

Figure 3. Automated Message Generation Screen Heirarchy

- REC. This function passes control to the Record Actions screen.
- MSG. This function passes control to the Message Actions screen.
- Formats. This function passes control to the Format Definition screen, where driver file format maintenance functions are accessed.
- Quit. This function causes an exit from this screen, without applying any changes to the current generator specification.

2.4.1.1.1 Generator Actions Screens

- a. Generator action blocks are maintained through the following screens:
 - Initialization Actions.
 - Driver File Record Actions.
 - Message Actions.
- b. The following functions are accessed through these screens:
 - Insert. This function allows the addition of an action line.
 - Delete. This function deletes an action line.
 - Quit. This function allows an exit from the actions screen, without applying any changes that were made to the data base.
- c. A basic set of actions have been implemented which can be expanded as additional processing requirements are identified.

2.4.1.1.2 Format Definition

This screen displays a list of formats and provides access to these functions:

- Create. This function creates a new format definition and passes control to the Format Specification screen.
- Specify. This function retrieves an existing format definition and passes control to the Format Specification screen.
- Delete. This function deletes a format definition.

2.4.1.1.2.1 Format Specification

This screen is used to view and modify format definitions. The following functions are accessed through this screen:

- Insert. This function adds a new field definition line.
- Delete. This function deletes a field definition line.
- Quit. This function allows the exit from this screen, without applying any changes.

2.4.2 Transaction File Index

This screen displays a list of tranfiles that have been created or modified. The following functions are accessible through this screen:

- List. This function generates a hard-copy listing of a tranfile.
- Delete. This function deletes a tranfile.
- Commit. This function applies the transactions of a tranfile to the test message data base.

2.4.3 Modifier Index

This screen displays a list of existing tranfile modifiers and provides access to the following functions:

- Create. This function creates a new modifier with default processing options specified. Control is then passed to the Modifier Specification screen.
- Specify. This function retrieves an existing modifier and passes control to the Modifier Specification screen.
- Delete. This function deletes an existing modifier.
- Modify. This function modifies a tranfile, using the specified processing options.
- List. This function generates a hard-copy listing of a modifier's processing options.

2.4.3.1 Modifier Specification

The Modifier Specification screen is used to view and modify the processing options of a modifier. The following functions are accessed through this screen:

- INIT. This function passes control to the Initialization Actions screen.
- TRAN. This function passes control to the Tranfile Record Actions screen.
- Quit. This function causes an exit from this screen, without applying any changes to the current modifier specification.

2.4.3.1.1 Modifier Actions Screens

- a. Modifier action blocks are maintained through the following screens:
 - Initialization Actions.
 - Tranfile Record Actions.
- b. The following functions are accessed through these screens:
 - Insert. This function allows the addition of an action line.
 - Delete. This function deletes an action line.
 - Quit. This function allows an exit from the actions screen, without applying any changes that were made to the data base.

APPENDIX A
METHODOLOGY INVESTIGATION PROPOSAL

September 1984

METHODOLOGY INVESTIGATION PROPOSAL

1. TITLE. Automated Aids to Test Data Generation.
2. CATEGORY. VISTA, DC3I, SMI/Interoperability, Software.
3. INSTALLATION. U.S. Army Electronic Proving Ground, Fort Huachuca, AZ 85613.
4. PRINCIPAL INVESTIGATOR. Richard Jacques, Software and Automation Branch, STEEP-MT-DA, AUTOVON 879-1879.
5. STATEMENT OF THE PROBLEM. A method is required for a test officer to generate technically significant sets of coordinated test messages for use in system-level testing of message-driven systems.
6. BACKGROUND.
 - a. History. The Army and DOD have developed and are continuing to develop a number of major automated, Command, Control, Communications, and Intelligence (C³I) systems. These include such systems as TACFIRE, Maneuver Control System, AN/TYC-39, AN/TSQ-73, and ASAS. These systems are designed to interface with a large number of interactive systems and to operate in a highly interactive environment. The critical element in the success or failure of these C³I systems will be their interoperability and performance under load in a highly interactive tactical environment. To date, no test capability exists which can fully evaluate the interoperability of these complex data handling systems.
 - b. A basic test message composition and manipulation capability was developed and demonstrated as part of the Interim Test Item Stimulator (ITIS) pre-test system. This process was further automated during the development of the Test Item Stimulator (TIS). However, scenario generation, the process of combining a multitude of messages and the information required to automatically control their application, was still found to be a labor intensive task.
7. GOAL. To develop methods of automatically generating information that can be inserted in scenarios during the composition and validation process. This will permit the test officer to generate test case data for testing message-driven systems.
8. DESCRIPTION OF INVESTIGATION.
 - a. Initially, a study will determine the degree of automation for which automated test data generation is feasible, and the cost benefit of automating the process. The development of requirements for instrumentation is not a part of this MIP. Work on the ongoing TIS will be examined and results of this investigation integrated into the TIS.
 - b. The USAEPG will conduct the investigation in two phases:

(1) Information on message types and contents and scenario structures will be compiled and analyzed to determine those scenario parameters and constructs that are used frequently and which are amenable to automatic generation.

(2) For several specific cases, methods of automatically generating the scenario contents will be proposed, computer programs designed, implemented, and tested, and scenarios generated and validated. The method and computer program will be documented to include a user's guide appropriate for the test officer.

c. Investigation Schedule.

MILESTONE/PHASE	SCHEDULE			
	FY 85 (Qtrs)			
	1	2	3	4
Scenario Analysis	x	x	x	
Propose Methods	x	x	x	
Implement and Test		x	x	x
Report				x

d. This investigation will result in a new procedure whereby the effectiveness of scenario generation can be improved.

e. Environmental Impact Statement. Execution of the investigation will not have an impact on the quality of the environment.

f. Health Hazard Statement. Execution of this investigation will not involve health hazards to personnel.

9. JUSTIFICATION.

a. Association with Mission. USAEPG's primary mission is to conduct development testing of C-E equipment and systems. In support of this mission, USAEPG has developed extensive experience in compatibility, vulnerability, and electronic warfare and intelligence testing and more recently has pioneered efforts in automated system (software) testing.

b. Capability, Limitations, Improvements, and Impact. The present scenario composition capability is manual with only the automated prompting and validation of operator entries for the composition of individual messages. This limits the timely accomplishment, the coordination of test messages, and the number of test cases that can be composed for the average test. Improvements can be realized by automated means of composing scenarios. The impact of failure to complete this investigation will be a reduced ability to generate the large amount of data required to test C³I systems.

c. Dollar Savings. In addition to providing a capability which was previously not available within TECOM, the manhour savings as gleaned from use of the initial capability on MCS is estimated to be a factor of 30.1.

d. Workload. The following major field Army automated systems are currently under development and are programmed for testing or retesting:

SYSTEM	TEST SCHEDULE (FY)					
	85	86	87	88	89	90
JTIOS	x	x	x	x		
MCS	x			x	x	x
RPV	x	x		x	x	
PLRS		x	x			
SHORAD C2			x	x	x	
JINTACCS			x	x	x	x
PJH	x	x	x	x		
GPS	x	x	x	x		
ASAS	x	x	x	x		
FIREFINDER			x	x	x	x

e. Association with Requirements Documentation. The Army Battlefield Automation Interoperability System Engineering Management Plan (BASEP), outlines the requirements for interoperability testing. This project will provide the capability for intra- and interoperability testing.

f. Other. None.

10. RESOURCES.

a. Financial.

(1) Funding Breakdown.

	Dollars (Thousands) FY 85	
	In-House	Out-of-House
Personnel Compensation	30.0	
Travel	3.0	
Contract Support		110.0
Consultants & Other Svcs.		10.0
Materials & Supplies	2.0	
Equipment		
ADP	20.0	
Subtotal	55.0	120.0
FY Total	175.0	

(2) Explanation of Cost Categories. (FY 85)

(a) Personnel Compensation. Direct labor, one civilian part-time chargeable to the investigation.

(b) Travel. Three to five trips per year charged to investigation.

(c) Contract Support. Required to complement in-house resources--includes consultants, materials, etc.

b. Anticipated Delays. None.

c. Obligation Plan. (Fiscal Quarters FY 85)

	FQ	1	2	3	4	Total
Obligation Rate (Thousands)		140.0	12.0	12.0	11.0	175.0

d. In-House Personnel.

Type	Number	FY 85 Manhours Required	Available
Electronic Engr GS-855	1	600	600
GS-334		600	600

Resolution of non-available personnel. NA.

11. INVESTIGATION SCHEDULE.

	FY 85											
	O	N	D	J	F	M	A	M	J	J	A	S
In-House	-	-	-							-	-	R
Contract	:	:	:	:	:	:	:	:	:	:	:	:

Symbols:

- Active investigation
- ... Contract monitoring
- R Final report at HQ, TECOM

12. ASSOCIATION WITH TOP PROGRAM

a. No TOP's will be revised as presently planned.

b. Initial plan does not include any TOP, but the investigation will supply the desired methods from which procedures can be formulated.

FOR THE COMMANDER:

MELVIN FOWLER
LTC, SigC
Director of Materiel Test

**APPENDIX B
ACRONYMS**

AMG.....Automated Message Generation
 ASAS.....All Source Analysis System
 ASCII.....American Standard Code for Information Interchange
 C³I.....Command, Control, Communications, and Intelligence
 C-E.....Communications-Electronics
 DB.....Data Base
 DBMS.....Data Base Management System
 DC³I.....Distributed C³I
 DOD.....Department of Defense
 EFL.....Event Format Library
 FY.....Fiscal Year
 GPS.....Global Positioning System
 INGRES.....Interactive Graphics and Retrieval System
 I/O.....Input/Output
 ITIS.....Interim Test Item Stimulator
 JINTACCS.....Joint Interoperability of Tactical Command and Control Systems
 JTIDS.....Joint Tactical Information Distribution System
 MCS.....Maneuver Control System
 MFL.....Message Format Library
 PJH.....PLRS/JTIDS Hybrid
 PLRS.....Position Location Reporting System
 RPV.....Remotely Piloted Vehicle
 SHORAD C².....Short-Range Air Defense Command and Control
 SMI.....Soldier Machine Interface
 SUT.....System Under Test
 TACFIRE.....Tactical Fire Direction System
 TECOM.....U.S. Army Test and Evaluation Command
 TIS.....Test Item Stimulator
 TMDB.....Test Message Data Base
 TRANFILE.....Data Base Transaction File
 USAEPG.....U.S. Army Electronic Proving Ground
 VISTA.....Very Intelligent Surveillance and Target Acquisition System

PREVIOUS PAGE
IS BLANK

APPENDIX C
TEST ITEM STIMULATOR
OVERVIEW

PREVIOUS PAGE
IS BLANK

1. TEST ITEM STIMULATOR OVERVIEW

The TIS supports three operational functions used to perform developmental and interoperability testing of digital message-driven systems:

- Pre-test scenario preparation.
- Real-time system under test (SUT) stimulation.
- Post-test data reduction and analysis.

Figure C-1 illustrates the data flow through the pre-test, real-time, and post-test functions.

1.1 Pre-Test

The pre-test function supports on-line generation, review, and modification of test scenarios. The pre-test software provides the interactive capability to maintain a data base of messages, called the Message Format Library (MFL). Using these message formats, scenario messages can be created and organized into groups, called events. Events, which are used to define scenarios, are maintained in the Event Format Library (EFL). The pre-test data base is further described in section 2 of this appendix.

1.2 Real-Time

The real-time function provides the interface for stimulating and monitoring the SUT. The real-time function processes scenario and operator-entered messages, producing a message stream to stimulate the SUT. The resulting message exchange is logged for later processing.

1.3 Post-Test

The post-test processing of the log files generated during testing produces statistical reports on message content and end-to-end system throughput.

2. TEST MESSAGE DATA BASE

The following sections describe that portion of the TIS test message data base related to scenarios, events, and message formats. Figure C-2 depicts the related data base sub-schema.

2.1 Scenarios

a. The time-sequenced scenario files, used by the real-time function, are generated from data base scenarios, created and maintained through the pre-test function. These scenarios are represented by the following types of records (to simplify the description, some fields have been renamed or omitted):

- Scenario description (System ID, Scenario ID, Scenario Description, Date Created, Date Modified).

PREVIOUS PAGE
IS BLANK

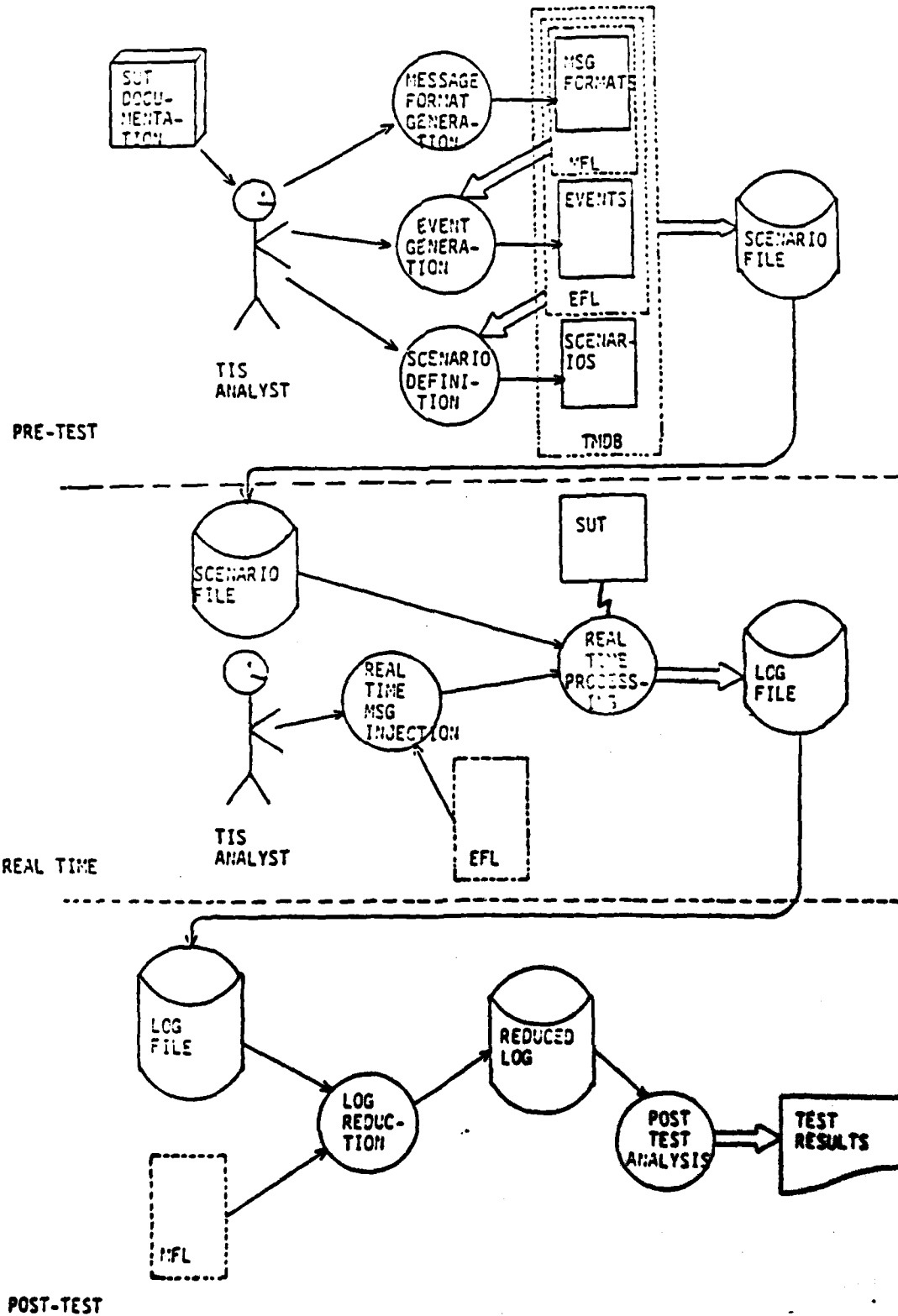

Figure C-1. Test Item Stimulator Data Flow

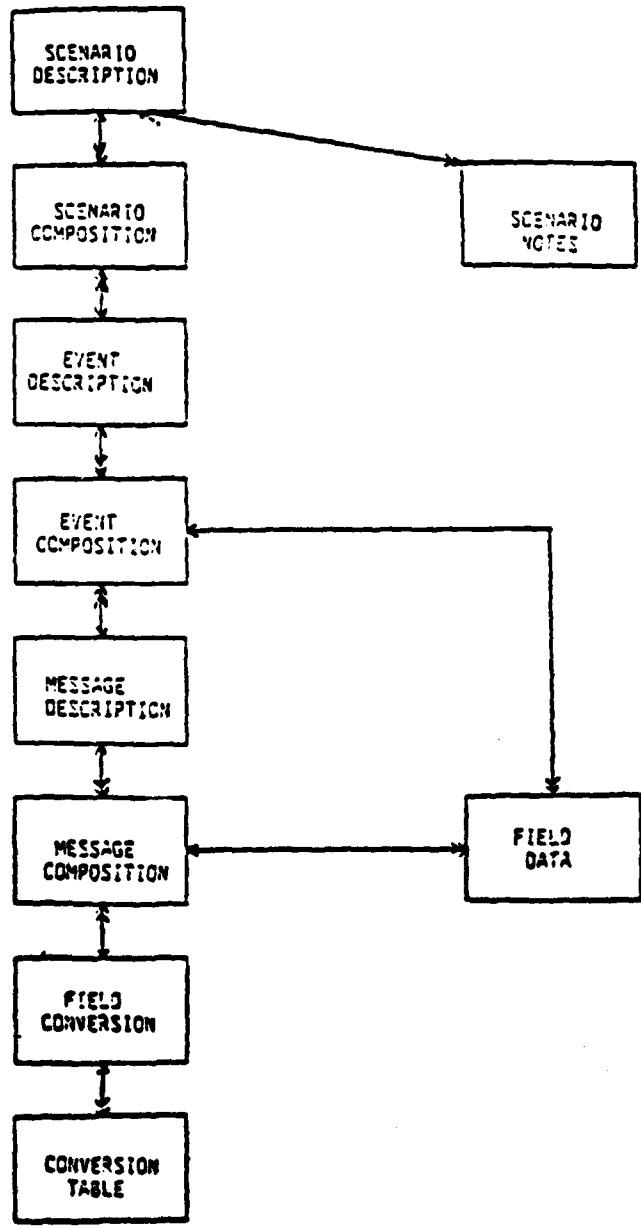

Figure C-2. Test Message Data Base Subschema

- Scenario notes (System ID, Scenario ID, Note #, Note Text).

- Scenario composition (System ID, Scenario ID, Event ID, Event Start Time).

The underlined fields, called key fields, have a unique combination of values for each record.

b. Each scenario is described by one Scenario Description record and a number of Scenario Notes records. The composition of each scenario is specified by a number of Scenario Composition records--one for each event used. All records associated with a specific scenario share the same System ID and Scenario ID. Scenario Notes records are ordered by their Note # fields, while Scenario Composition records are differentiated by their Event ID and Event Start Time fields (a scenario can contain several instances of an event, so long as they have different start times).

2.2 Events

a. Events are represented by the following types of records:

- Event description (System ID, Event ID, Event Description).

- Event composition (System ID, Event ID, Message Delta Time, Segment #, Message Type, Message Index, Control Fields).

b. Each event is described by an Event Description record, which is associated by the System ID and Event ID with a number of Event Composition records. Events are composed of messages, which are made up of one or more segments. Each message of an event is described by one or more Event Composition records as follows:

- Single segment messages. Single segment messages are represented by a single Event Composition record--no other Event Composition records share the same combination of System ID, Event ID, and Message Delta Time values.

- Multiple segment messages. Multiple segment messages are defined using two or more Event Composition records sharing the same System ID, Event ID, and Message Delta Time fields. These records represent individual message segments to be combined during real-time scenario file generation where concatenation order is based on the Segment # values. Unless otherwise indicated, message segments of multiple segment messages will be treated as if they were single segment messages.

c. The Message Delta Time fields specify each message's offset from the Event Start Time of that particular event. The message type field specifies the format (field structure) of each message or segment. The various control fields contain processing data used during scenario file generation and real-time processing.

d. The System ID, Event ID, Message Delta Time, and Segment # fields are collectively referred to as the message key fields.

e. The message index field is used to access the actual message data fields which are stored in the following type of record:

Field Data (Message Index, Field #, Data)

The data fields associated with a particular message are stored in Field Data records that have the same message index value as the Message Index field in that message's Event Composition record.

2.3 Message Formats

a. The following types of data base records are used to define message formats:

- Message Description (System ID, Message Type, Description).
- Message Composition (System ID, Message Type, Field #, Field Type, Field Location).
- Field Conversion (System ID, Field Type, Conversion Data).
- Conversion Table (System ID, Field Type, ASCII Value, Bit Value).

b. Message formats are described with a Message Description record. Each field of a particular type of message is defined using Message Composition records that share the same System ID and Message Type. The Field Type value indicates the field's type, which is detailed by a Field Conversion record. The Field Conversion information is used with the Conversion Table information during the scenario generation process, where the character-oriented data base scenario is converted into the real-time scenario file.

APPENDIX D
DISTRIBUTION

PREVIOUS PAGE
IS BLANK

DISTRIBUTION LIST

<u>Addressee</u>	<u>Number of Copies</u>
Commander U.S. Army Test and Evaluation Command ATTN: AMSTE-TC-M	3
AMSTE-TO	2
AMSTE-EV-S	1
AMSTE-TE	6
Aberdeen Proving Ground, MD 21005-5055	
Commander Defense Technical Information Center ATTN: DTIC-DDR	2
Cameron Station Alexandria, VA 22314-5000	
Commander U.S. Army Aberdeen Proving Ground ATTN: STEAP-MT-M	2
Aberdeen Proving Ground, MD 21005-5000	
Commander U.S. Army Yuma Proving Ground ATTN: STEYP-MSA	2
Yuma, AZ 85364-5000	
Commander U.S. Army Jefferson Proving Ground ATTN: STEJP-TD-E	1
Madison, IN 47250-5000	
Commander U.S. Army Dugway Proving Ground ATTN: STEDP-PO-P	1
Dugway, UT 84022-5000	
Commander U.S. Army Cold Regions Test Center ATTN: STECR-TM	1
APO Seattle, WA 98733-5000	
Commander U.S. Army Electronic Proving Ground ATTN: STEEP-TM-AC	4
Fort Huachuca, AZ 85613-7110	

PREVIOUS PAGE
IS BLANK

Addressee

Number
of Copies

Commander
U.S. Army Tropic Test Center
ATTN: STETC-TD-AB
APO Miami, FL 34004-5000

1

Commander
U.S. Army White Sands Missile Range
ATTN: STEWS-TE-PY
 STEWS-TE-O
 STEWS-TE-M
 STEWS-TE-A

4

1

1

1

White Sands Missile Range, NM 88002-5000

END

FILMED

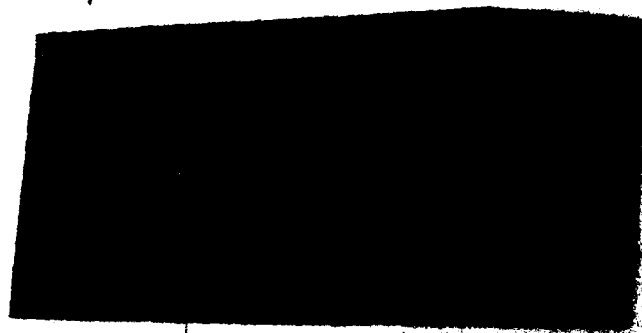

DTIC