

MICROCOPY RESOLUTION TEST CHART
NATIONAL BUREAU OF STANDARDS-1963-A

The mooring line is assumed to have the following properties:

Material	Kevlar 29
Construction	6 x 19 stranded with independent core
Jacket	Polyurethane
Diameter	0.61 in.
Weight in Air	0.114 lbs/ft
Weight in Water	0.0 lbs/ft
Breaking Strength	30,000 lbs

The normal and tangential hydrodynamic cable drag coefficients were assumed to be

ADA 165508

Unclassified

SECURITY CLASSIFICATION OF THIS PAGE

REPORT DOCUMENTATION PAGE

1a. REPORT SECURITY CLASSIFICATION
Unclassified

1b. RESTRICTIVE MARKINGS

2a. SECURITY CLASSIFICATION AUTHORITY

3. DISTRIBUTION AVAILABILITY OF REP.
Approved for public release;
distribution is unlimited

2b. DECLASSIFICATION/DOWNGRADING SCHEDULE

4. PERFORMING ORGANIZATION REPORT NUMBER
FPO-1-77(28)

5. MONITORING ORGANIZATION REPORT #

6a. NAME OF PERFORM. ORG.
Ocean Engineering
& Construction
Project Office
CHESNAVFACENGCOM

6b. OFFICE SYM

7a. NAME OF MONITORING ORGANIZATION

6c. ADDRESS (City, State, and Zip Code)
BLDG. 212, Washington Navy Yard
Washington, D.C. 20374-2121

7b. ADDRESS (City, State, and Zip)

8a. NAME OF FUNDING ORG.

8b. OFFICE SYM

9. PROCUREMENT INSTRUMENT INDENT #

8c. ADDRESS (City, State & Zip)

10. SOURCE OF FUNDING NUMBERS			
PROGRAM ELEMENT #	PROJECT #	TASK #	WORK UNIT ACCESS #

11. TITLE (Including Security Classification)
Dynamic Analysis of the Pixie Buoy for Project Linear Chair

12. PERSONAL AUTHOR(S)

13a. TYPE OF REPORT

13b. TIME COVERED
FROM TO

14. DATE OF REP. (YYMMDD)
77-09

15. PAGES
47

16. SUPPLEMENTARY NOTATION

17. COSATI CODES		
FIELD	GROUP	SUB-GROUP

18. SUBJECT TERMS (Continue on reverse if nec.)
Linear Chair, Dynamic analysis, Buoys,
Pixie buoy

19. ABSTRACT (Continue on reverse if necessary & identify by block number)
The PIXIE Buoy has been chosen as the initial platform to be used for acquiring airborne magnetic, electric, and electromagnetic measurements during the preliminary sea trials of the LINEAR CHAIR system in FY 80. A mooring system must be developed that will minimize buoy motion response in both
(Con't)

20. DISTRIBUTION/AVAILABILITY OF ABSTRACT
SAME AS RPT.

21. ABSTRACT SECURITY CLASSIFICATION

22a. NAME OF RESPONSIBLE INDIVIDUAL
Jacqueline B. Riley
DD FORM 1473, 84MAR

22b. TELEPHONE
202-433-3881

22c. OFFICE SYMBOL

SECURITY CLASSIFICATION OF THIS PAGE

BLOCK 19 (Con't)

shallow (100 to 200 feet) and deep (2000 to 3000 feet) water configurations. The following analytical data are illustrative of a technique to predict and evaluate the expected responses of the PIXIE Buoy under various sea conditions and mooring configurations. These equations and graphs are meant as an aid to the investigator in designing the optimum mooring configuration for the buoy with regards to allowable motion and tilt as determined by the sensitivity of the buoy-mounted instruments. Actual numerical values presented are only illustrative as they do not reflect the actual configuration of the PIXIE Buoy as it will be used in the LINEAR CHAIR tests. Once the actual numerical values for the various parameters have been established, the following technique can be used to generate more accurate values of the buoy response.



FPO-1-77(28)
SEPTEMBER 1977

**DYNAMIC ANALYSIS OF THE PIXIE BUOY
FOR PROJECT LINEAR CHAIR**

PREPARED FOR
OCEAN ENGINEERING AND CONSTRUCTION PROJECT OFFICE
CHESAPEAKE DIVISION
NAVAL FACILITIES ENGINEERING COMMAND
WASHINGTON, D.C. 20374

DYNAMIC ANALYSIS OF THE PIXIE BUOY

The PIXIE Buoy has been chosen as the initial platform to be used for acquiring airborne magnetic, electric, and electromagnetic measurements during the preliminary sea trials of the LINEAR CHAIR system in FY 80. A mooring system must be developed that will minimize buoy motion response in both shallow (100 to 200 feet) and deep (2000 to 3000 feet) water configurations. The following analytical data are illustrative of a technique to predict and evaluate the expected responses of the PIXIE Buoy under various sea conditions and mooring configurations. These equations and graphs are meant as an aid to the investigator in designing the optimum mooring configuration for the buoy with regards to allowable motion and tilt as determined by the sensitivity of the buoy-mounted instruments. Actual numerical values presented are only illustrative as they do not reflect the actual configuration of the PIXIE Buoy as it will be used in the LINEAR CHAIR tests. Once the actual numerical values for the various parameters have been established, the following technique can be used to generate more accurate values of the buoy response.

Accession For	
NTIS CRA&I	<input checked="" type="checkbox"/>
DTIC TAB	<input type="checkbox"/>
Unannounced	<input type="checkbox"/>
Justification	
By	
Distribution/	
Availability Codes	
Dist	Avail and/or Special
A-1	

TABLE OF CONTENTS

<u>Section</u>		<u>Page</u>
1	STEADY STATE PITCH	1-1
	1.1 Buoy Pitch Versus Submergence and Current Speed	1-1
	1.2 Buoy Pitch Versus Mooring Line Scope.	1-6
2	DYNAMICS OF A FREE FLOATING BUOY	2-1
	2.1 Natural Frequency of Roll	2-1
	2.2 Free Floating Buoy Righting Moment	2-5
	2.2.1 Righting Moment Due to Buoy Tilt	2-5
	2.2.2 Moment Due to Wave Slope	2-5
	2.2.3 Moment Due to Buoy Tilt and Wave Slope	2-5
	2.3 Equation of Motion for Free Floating Buoy	2-9
	2.4 Linearized Damping Coefficient	2-11
	2.5 Statistical Roll Response to Ocean Waves Excitation	2-14
3	DYNAMICS OF MOORED BUOY	3-1
	3.1 Restoring Moment	3-1
	3.2 Equation of Motion	3-5
	3.3 Response to Spectrum	3-7

LIST OF ILLUSTRATIONS

<u>Figure</u>		<u>Page</u>
1-1	PXIE Buoy Freebody Diagram	1-2
1-2	Steady State Buoy Pitch as a Function of Buoy Submergence and Current Speed	1-5
1-3	PXIE Buoy Mooring Scenario	1-7
1-4	Buoy Submergence versus Mooring Line Scope and Current Profile Speed	1-10
2-1	Geometry of the Restoring Forces Due to Buoy Tilt	2-6
2-2	Geometry of the Restoring Forces Due to the Wave Slope	2-7
2-3	Geometry of the Restoring Forces Due to Buoy Tilt and the Wave Slope	2-8
2-4	Damping Force	2-12
2-5	PXIE Buoy Roll Response Amplitude Operator	2-16
2-6	Pierson-Moskowitz Double Height Spectrum for a 30-knot Wind Speed	2-17
2-7	Roll Response Spectrum for a 30-knot Wind Speed Wave Height Spectrum	2-18
2-8	Mean Roll Response as a Function of Wind Speed	2-19
3-1	Moored Buoy Force Diagram	3-2
3-2	Roll Response Amplitude Operator for a Moored PXIE Buoy	3-11
3-3	Pierson-Moskowitz Double Wave Height Spectrum for a Typical 30-knot Wind Speed as a Function of Frequency	3-12
3-4	Moored PXIE Buoy Roll Response Spectrum for a 30-knot Wind Speed Wave Height Spectrum	3-13
3-5	Moored Buoy Mean Roll Response as a Function of Wind Speed	3-14

Section 1

STEADY STATE PITCH

1. BUOY PITCH VERSUS SUBMERGENCE AND CURRENT SPEED

The PIXIE Buoy is depicted in Figure 1-1 as a free body with the steady state forces acting on it. The current is acting on the buoy from the right hand side and the forces T_x and T_y represent the horizontal and vertical components of tension which the buoy imparts to the mooring line.

Two waterlines are shown in Figure 1-1. The lower of the two, the free floating waterline, represents the case where the buoy is freely floating in still water (i.e., no current) and no mooring line attached. It is located a distance L_0 from the bottom of the buoy. The higher of the two, the loaded waterline, represents the case where the buoy is moored in a current. The parameter H represents the distance between the two water lines, or in other words, the buoy submergence.

The forces D_N and D_T represent the normal and tangential components of hydrodynamic drag due to the steady state current. For a uniform current acting in the region of the buoy (assumed for this analysis) the drag forces will act at the mid-point of the submerged portion which is located at a distance of $(L_0 + H)/2$ from the bottom of the buoy.

The forces W and B represent the buoy weight and buoyancy acting at distances of L_w and L_B from the bottom of the buoy. The buoyancy force, B , represents the free floating or unloaded displacement. The increased buoyancy, ΔB , due to the buoy submergence from the free floating condition acts at a distance of $L_0 + H/2$ from the bottom of the buoy.

The angle, ϵ , is the resultant buoy steady state pitch angle.

A summary of the buoy physical parameters are presented in Table 1-1

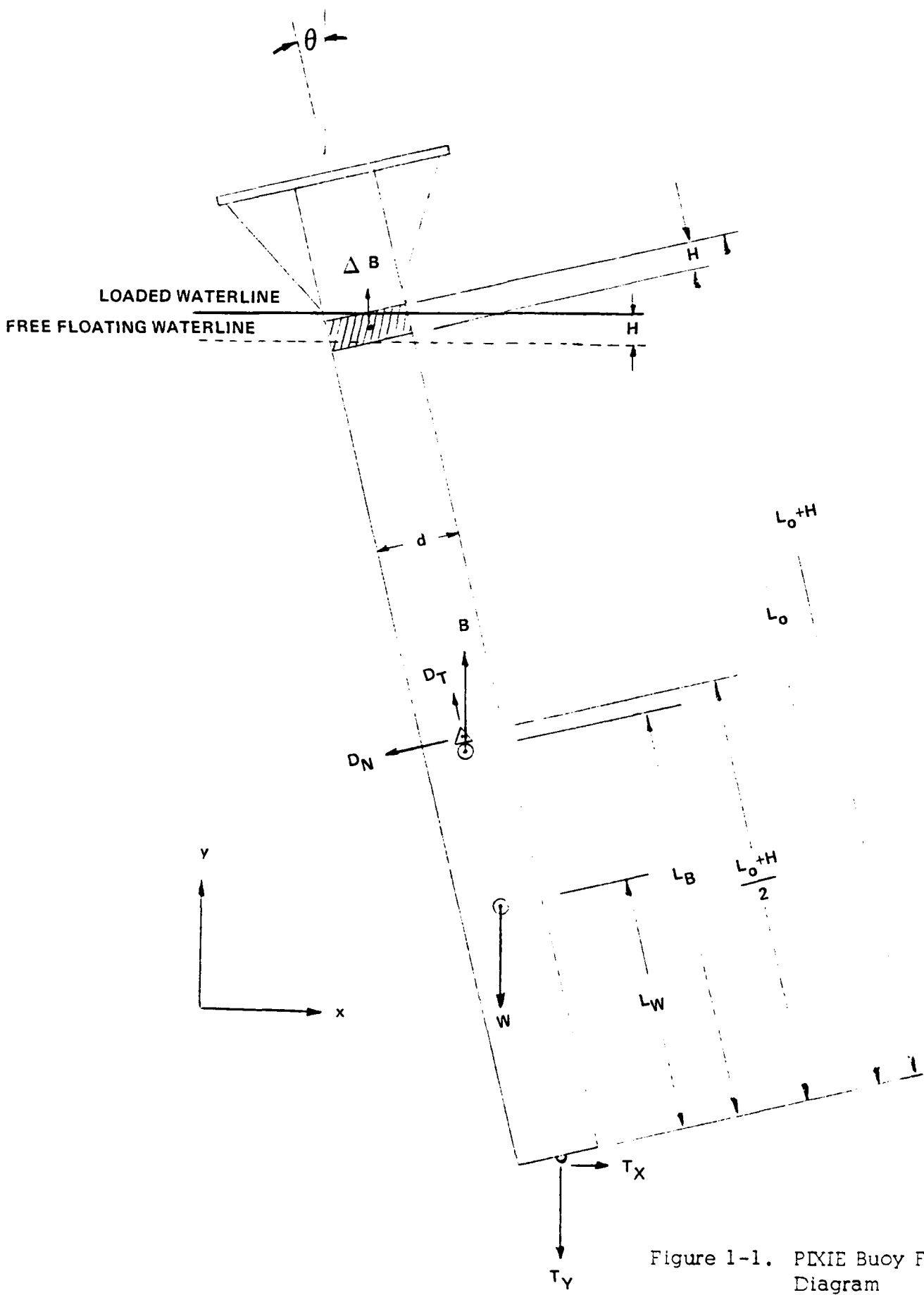

Figure 1-1. PKIE Buoy Freebody Diagram

Table 1-1. PIXIE Buoy Physical Parameters

Buoy Weight	W	57,169 lbs
Free Floating Buoyancy	B	57,169 lbs
Buoy Diameter	d	4.77 ft
Free Floating Waterline	L_o	50 ft
C.G. Location	L_w	15.53 ft
C. B. Location	L_B	24.99 ft

Summing the forces in the x and y directions and the moments about the towpoint we get:

$$\sum F_x = 0$$

$$T_x = D_N \cos \theta + D_T \sin \theta$$

$$\sum F_y = 0$$

$$T_y = B + \Delta B - W + D_T \cos \theta - D_N \sin \theta$$

$$\sum M = 0$$

$$BL_B \sin \theta + \Delta B \left(L_o + \frac{H}{2} \right) \sin \theta - D_N \left(\frac{L_o + H}{2} \right) - W L_w \sin \theta = 0$$

$$\left(BL_B + \Delta B \left(L_o + \frac{H}{2} \right) - W L_w \right) \sin \theta = D_N \left(\frac{L_o + H}{2} \right)$$

$$\theta = \sin^{-1} \left[\frac{D_N \left(\frac{L_o + H}{2} \right)}{BL_B + \Delta B \left(L_o + \frac{H}{2} \right) - W L_w} \right]$$

The normal hydrodynamic force, D_N , is given by

$$D_N = 1/2 \rho C_{N_B} A_f (V \cos \theta)^2$$

where V is the current speed, $V \cos \theta$ is the component of velocity normal to the cylinder, ρ is the fluid density, C_{N_B} is the normal drag coefficient, and A_f is the projected frontal area given by

$$A_f = (L_o + H)d$$

Therefore, the buoy pitch angle is given by

$$\theta = \text{Sin}^{-1} \left[\frac{1/2 \rho C_{N_B} (L_o + H) d V^2 \cos^2 \theta \left(\frac{L_o + H}{2} \right)}{BL_B + \Delta B \left(L_o + \frac{H}{2} \right) - WL_w} \right]$$

the increased buoyancy, ΔB , is given by

$$\Delta B = \rho g \frac{\pi d^2}{4} H$$

For small angles of θ , then

$$\cos \theta \approx 1$$

$$\cos^2 \theta \approx 1$$

and the expression for θ reduces to

$$\theta = \text{Sin}^{-1} \left[\frac{\rho C_{N_B} (L_o + H)^2 d V^2}{4BL_B + \rho g \pi d^2 H \left(L_o + \frac{H}{2} \right) - 4 WL_w} \right]$$

For values of buoy submergence, H , between 0 and 8 feet and for current speeds, V , between 0.1 and 1.0 knots the resultant pitch angles, θ , are shown in Figure 1-2. The values of the constants used in the above calculations were assumed to be as follows:

$$C_{N_B} = 1.2$$

$$\rho = 1.99 \text{ slugs/ft}^3$$

$$g = 32.2 \text{ ft/sec}^2$$

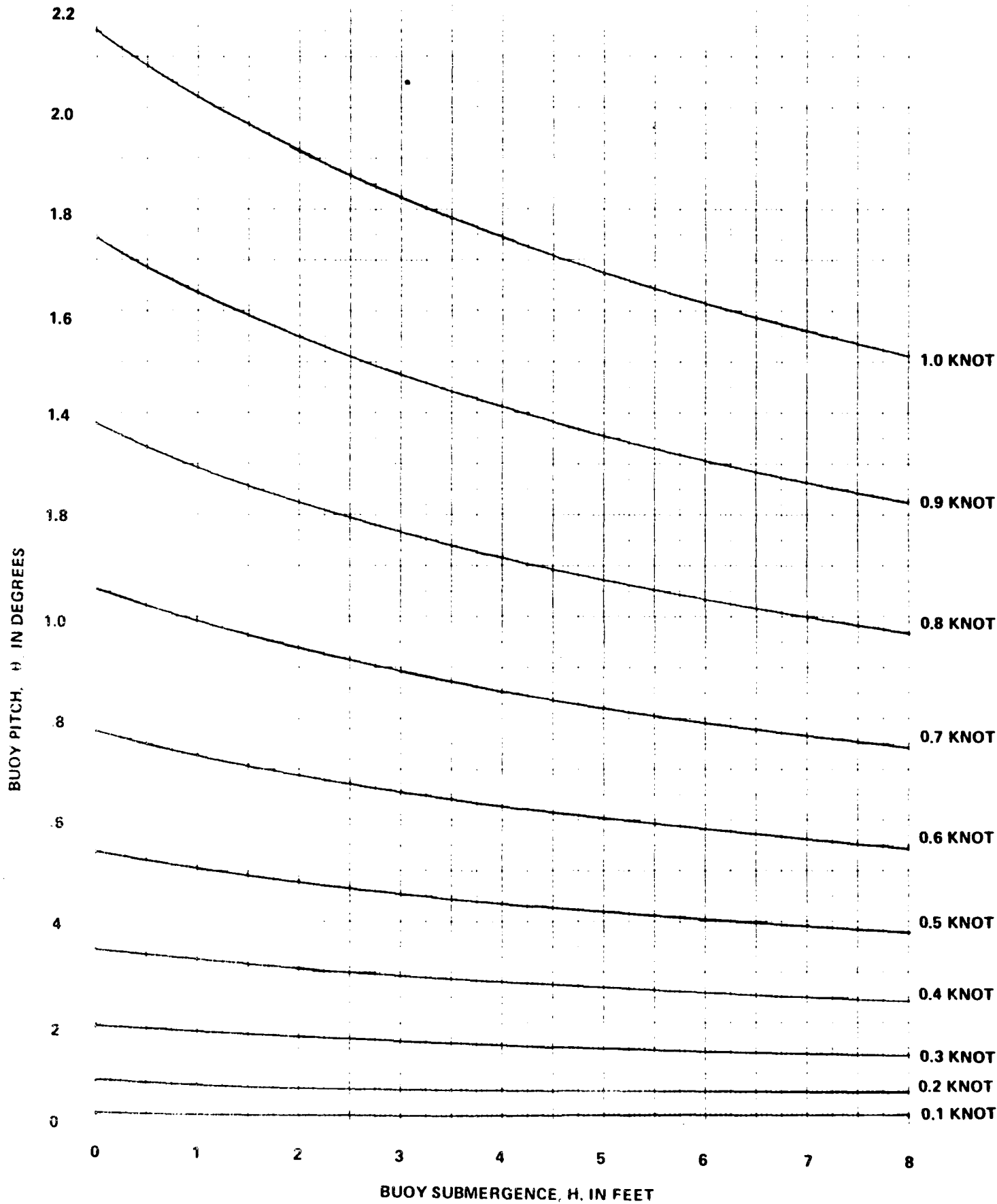

Figure 1-2. Steady State Buoy Pitch as a Function of Buoy Submergence and Current Speed

1.2 BUOY PITCH VERSUS MOORING LINE SCOPE

Until now the steady state buoy pitch angle has been described strictly in terms of the buoy as a free body by itself where the buoy submergence, H , has been a variable parameter. It has been shown that for a given current speed and a given buoy submergence there is one and only one resultant buoy pitch angle. The buoy submergence parameter is not an independent variable, however. The key to this problem lies in the tension vector resulting from the mooring line constraint. The parameter H must now be related to some other parameter of the overall mooring system.

It can be shown that for a given current profile, water depth, mooring line scope and buoy, the mooring system will assume some steady state equilibrium configuration. That is, for any one set of conditions there will be one and only one resultant mooring line spatial geometry, and there will be one and only one resultant buoy attitude in terms of forces, pitch angle and submergence. Therefore, for a given current profile the resultant buoy submergence (and therefore buoy pitch) is a function only of mooring line scope.

In reality, scope and current speed would be the independent parameters and buoy submergence would be the dependent parameter. However, since there is a one to one correspondence between scope and submergence, it is convenient for the purpose of this analysis to reverse the relationship and make submergence and current speed the independent parameters and scope the dependent parameter.

The approach is to evaluate the relationships for T_x and T_y previously formulated as a function of buoy submergence and use the resultant tension vector as an initial condition to the computer program TOWLIN to calculate the mooring line scope required to traverse the depth of water. The mooring configuration scenario is depicted in Figure 1-3.

It is assumed that the water depth is 2000 feet. It is further assumed that the surface current acts only in the region of the buoy (approximately 0-50 feet below the surface) and that the subsurface current speed is 30 percent of the surface current speed.

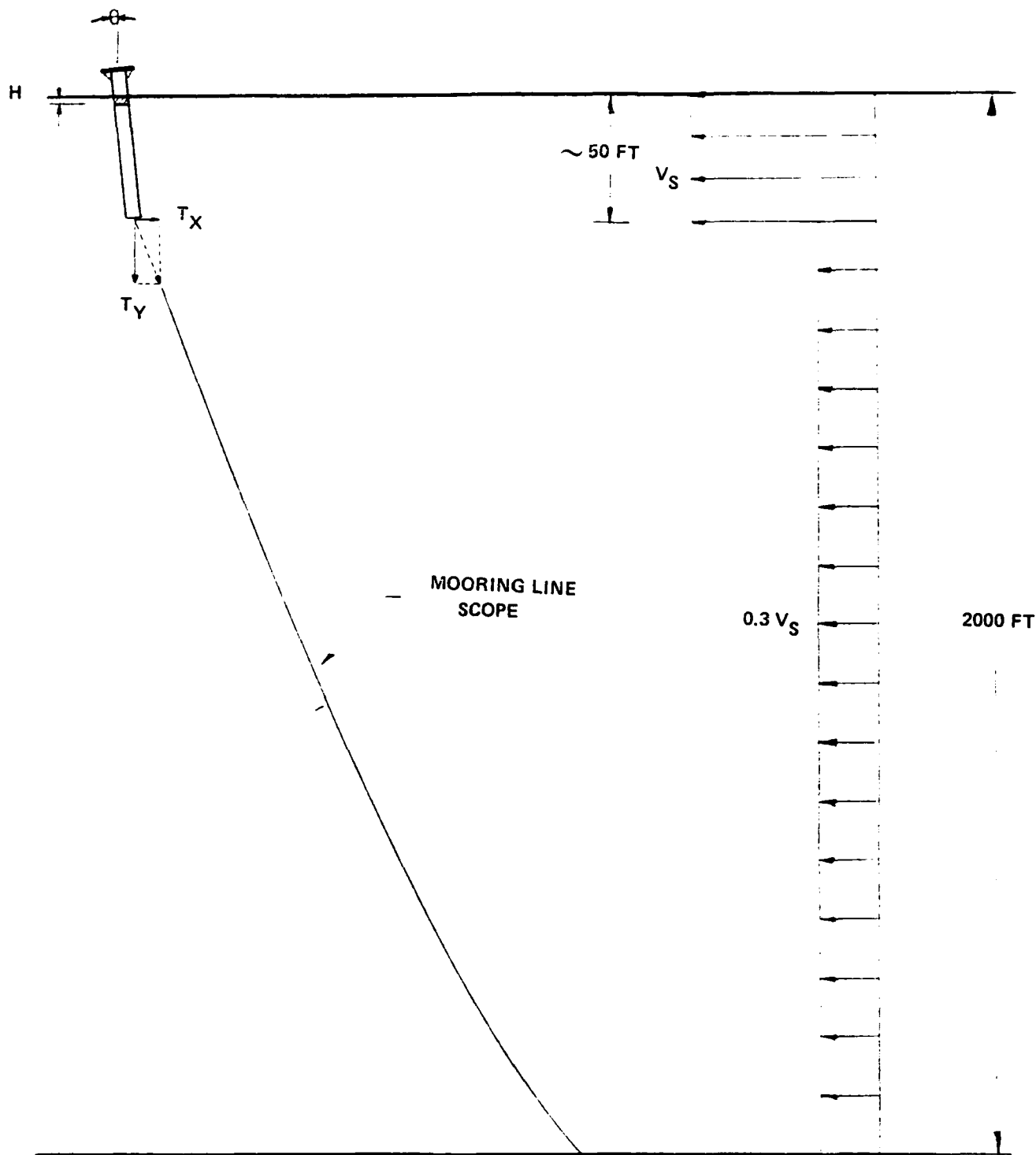

Figure 1-3. PLXIE Buoy Mooring Scenario

The mooring line is assumed to have the following properties:

Material	Kevlar 29
Construction	6 x 19 stranded with independent core
Jacket	Polyurethane
Diameter	0.61 in.
Weight in Air	0.114 lbs/ft
Weight in Water	0.0 lbs/ft
Breaking Strength	30,000 lbs

The normal and tangential hydrodynamic cable drag coefficients were assumed to be

$$C_{N_c} = 1.5$$

$$C_{T_c} = .005$$

As previously formulated, the resultant components of tension, T_x and T_y , at the buoy are given by

$$T_x = D_N \cos \theta + D_T \sin \theta$$

$$T_y = \rho g \frac{\pi d^2}{4} H + D_T \cos \theta - D_N \sin \theta$$

where

$$D_N = 1/2 \rho C_{N_B} (L_o + H) d V^2 \cos^2 \theta$$

$$D_T = 1/2 \rho C_{T_B} (L_o + H) d V^2 \sin^2 \theta$$

$$\theta = \sin^{-1} \left[\frac{\rho C_{N_B} (L_o + H)^2 d V^2}{4 B L_B + \rho g \pi d^2 H (L_o + \frac{H}{2}) - 4 W L_w} \right]$$

Using T_x and T_y , the initial conditions to the mooring problems, the computer program TOWLIN numerically integrates the differential equations which describe the tension in the cable and the curvature of the cable due to the hydrodynamic and weight forces acting on an incremental length of cable. The program proceeds with the integration until the specified depth of 2000 feet is reached. The resulting cable scope as a function of buoy submergence, H , for two current profiles is presented in Figure 1-4.

It can be seen that there is a strong dependence of buoy submergence on mooring line scope. Proceeding from left to right past the knee of the curve there is only a very slight decrease in cable scope required for a large increase in submergence. This is because the mooring system is extremely taut (almost vertical). In this regime the dominant force is buoyancy, ΔB , due to submergence. On the left side of the knee a large increase in scope results in a very small decrease in submergence (i.e., the buoy is approaching the freely floating case). This regime is called a slack line configuration where the dominant buoy force is drag.

To determine the resultant buoy pitch angle, the following procedures would be used.

1. For a specified mooring line scope and current speed determine the buoy submergence, H , from Figure 1-4.
2. For the same current speed and for the value of submergence determined in Step 1, the buoy pitch angle can be determined from Figure 1-2.

For example, for a current profile with a 1.0 knot surface current and for a scope of 2100 feet, the submergence, H , equals 1.86 feet. Referring to Figure 1-2 for a 1.86 foot submergence for a 1.0 knot current speed the resultant buoy pitch angle, θ , is 1.93 degrees.

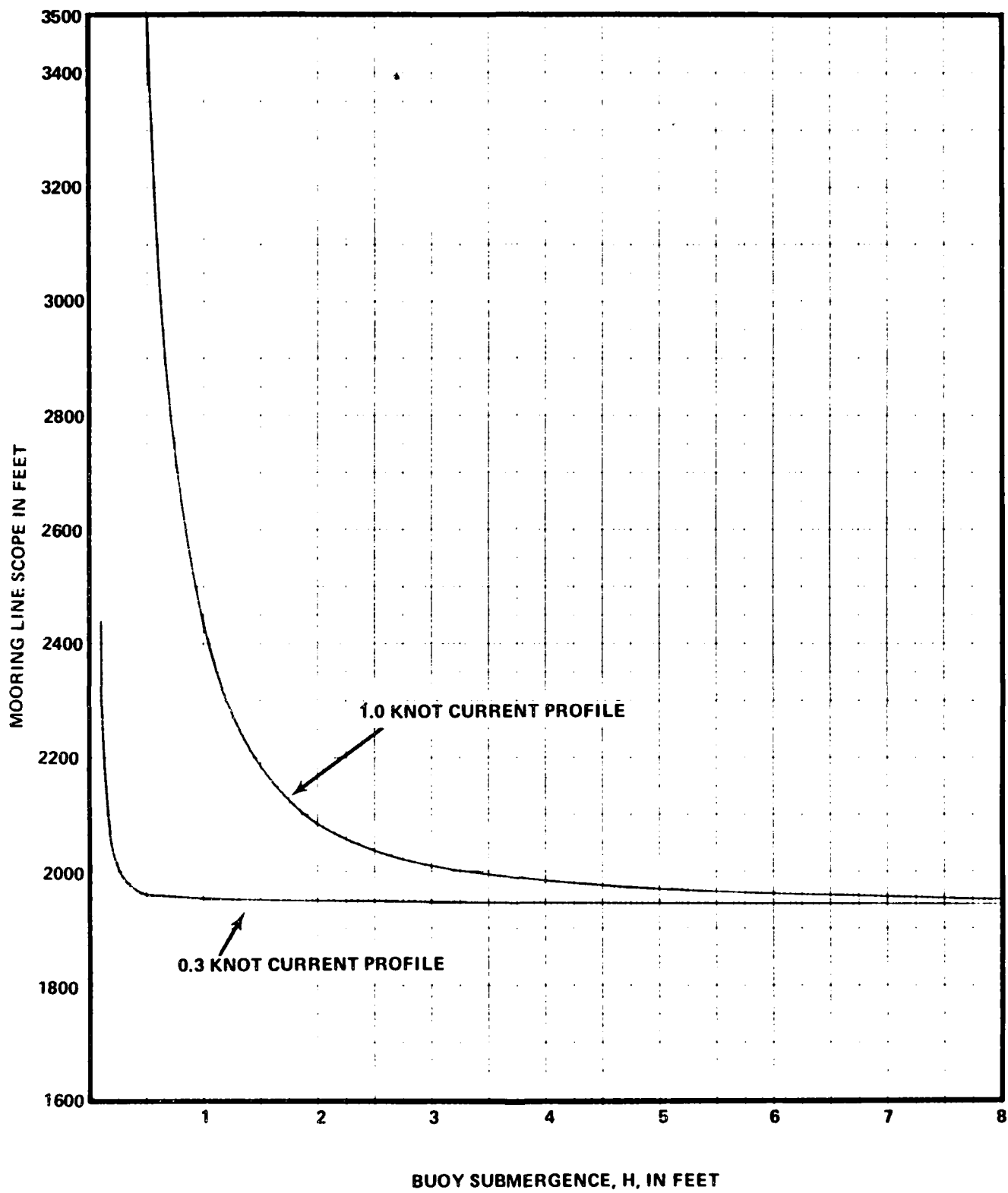

Figure 1-4. Buoy submergence versus Mooring Line Scope and Current Profile Speed

Section 2

DYNAMICS OF A FREE FLOATING BUOY

2.1 NATURAL FREQUENCY OF ROLL

The natural frequency of roll (or pitch), f_o , for a freely floating buoy is given by

$$f_o = \frac{1}{2\pi} \sqrt{\frac{W \overline{gm}}{I_v}}$$

where

W is the buoy weight

\overline{gm} is the buoy metacentric height

I_v is the buoy mass moment of inertia about the axis of pitch through the center of gravity

The metacentric height, \overline{gm} , is given by

$$\overline{gm} = \frac{I_{wp}}{V} + \overline{gb}$$

where

I_{wp} is the moment of inertia of the waterplane area

V is the displaced volume of water

\overline{gb} is the distance between the centers of buoyancy and gravity

$$I_{wp} = \frac{\pi R^4}{4} = \frac{\pi \left(\frac{4.77}{2} \right)^4}{4}$$

$$I_{wp} = 25.41 \text{ ft}^4$$

$$\overline{gb} = 9.46 \text{ ft}$$

$$V = \pi R^2 L_o = \left(\frac{4.77}{2} \right)^2 (50)$$

$$V = 893.5 \text{ ft}^3$$

Therefore,

$$\bar{gm} = \frac{25.41 \text{ ft}^4}{893.5 \text{ ft}^3} + 9.46 \text{ ft}$$

$$\bar{gm} = 9.49 \text{ ft}$$

The virtual moment of inertia, I_v , is given by

$$I_v = I + I'$$

where I is the buoy mass moment of inertia and I' is the mass moment of inertia of the entrained water.

Using the parallel axis theorem and theorem of composite shapes, the total buoy mass moment of inertia, I , is given by

$$I = \sum_i (\bar{I}_i + M_i d_i^2)$$

where

\bar{I}_i is the principle moment for the i^{th} component

M_i is the mass of the i^{th} component

d_i is the distance between the center of gravity of the i^{th} component and the center of gravity of the buoy

For the aluminum shell,

$$I_A = M_A \left(\frac{R^2}{2} + \frac{L^2}{12} \right)$$

$$I_A = \frac{7753}{32.2} \left(\frac{4.77^2}{8} + \frac{60^2}{12} \right)$$

$$I_A = 72,918 \text{ ft} - \text{lb} - \text{sec}^2$$

For the sand,

$$I_s = M_s \left(\frac{R^2}{4} + \frac{L_s^2}{12} \right)$$

$$I_s = \frac{40000}{32.2} \left(\frac{4.77^2}{16} + \frac{18.28^2}{12} \right)$$

$$I_s = 36,359 \text{ ft} - \text{lb} - \text{sec}^2$$

For the water inside the buoy,

$$I_w = M_w \left(\frac{R^2}{4} + \frac{L_w^2}{12} \right)$$

$$I_w = \frac{9416}{32.2} \left(\frac{4.77^2}{16} + \frac{(26.73 - 18.28)^2}{12} \right)$$

$$I_w = 2,156 \text{ ft} - \text{lb} - \text{sec}^2$$

The total moment of inertia is then

$$I = I_A + M_A d_A^2 + I_s + M_s d_s^2 + I_w + M_w d_w^2$$

$$I = 226,797 \text{ ft} - \text{lb} - \text{sec}^2$$

The moment of inertia of the entrained water is given by

$$I' = M \left[\left(\frac{R^2}{4} + \frac{L_o^2}{12} \right) + \bar{g}b^2 \right]$$
$$I' = \frac{57,169}{32.2} \left[\left(\frac{4.77^2}{16} + \frac{50^2}{12} \right) + 9.41^2 \right]$$

$$I' = 531,577 \text{ ft} - \text{lb} - \text{sec}^2$$

$$I_v = I + I'$$

$$I_v = 758,374 \text{ ft} - \text{lb} - \text{sec}^2$$

The natural frequency, f_o , is therefore

$$f_o = \frac{1}{2\pi} \sqrt{\frac{(57169 \text{ lbs}) (9.49 \text{ ft})}{758,374 \text{ ft-lb-sec}^2}}$$

$$f_o = 0.1346 \text{ CPS}$$

$$T_o = \frac{1}{f_o} = 7.43 \text{ seconds}$$

2.2 FREE FLOATING BUOY RIGHTING MOMENT

The righting moment acting on a free floating buoy can be expressed in terms of the righting moment due to buoy tilt, due to the wave slope, and due to a combination of the two.

2.2.1 Righting Moment Due to Buoy Tilt

Righting Moment due to buoy tilt is expressed as

$$M = W\overline{gm} \sin \theta$$

and is illustrated in Figure 2-1. The metacentric height \overline{gm} is given by

$$\overline{gm} = \overline{bg} + \lim_{\theta \rightarrow 0} \overline{bm'}$$

$$\overline{gm} = \overline{bg} + \overline{bm}$$

$$\overline{gm} = \overline{bg} + \frac{I_{wp}}{\nabla}$$

where ∇ is the submerged volume.

For small angles of tilt, the expression for the restoring moment can be linearized such that

$$M = W\overline{gm} \theta$$

2.2.2 Moment Due to Wave Slope

The moment due to wave slope as shown in Figure 2-2 is exactly the same as for buoy tilt but acts in the opposite rotational direction.

That is,

$$M = -W\overline{gm} \sin \phi$$

$$M = -W\overline{gm} \phi$$

2.2.3 Moment Due to Buoy Tilt and Wave Slope

Figure 2-3 illustrates the geometry for a combination of buoy tilt and wave slope. From the previous expressions it follows that the moment is given by

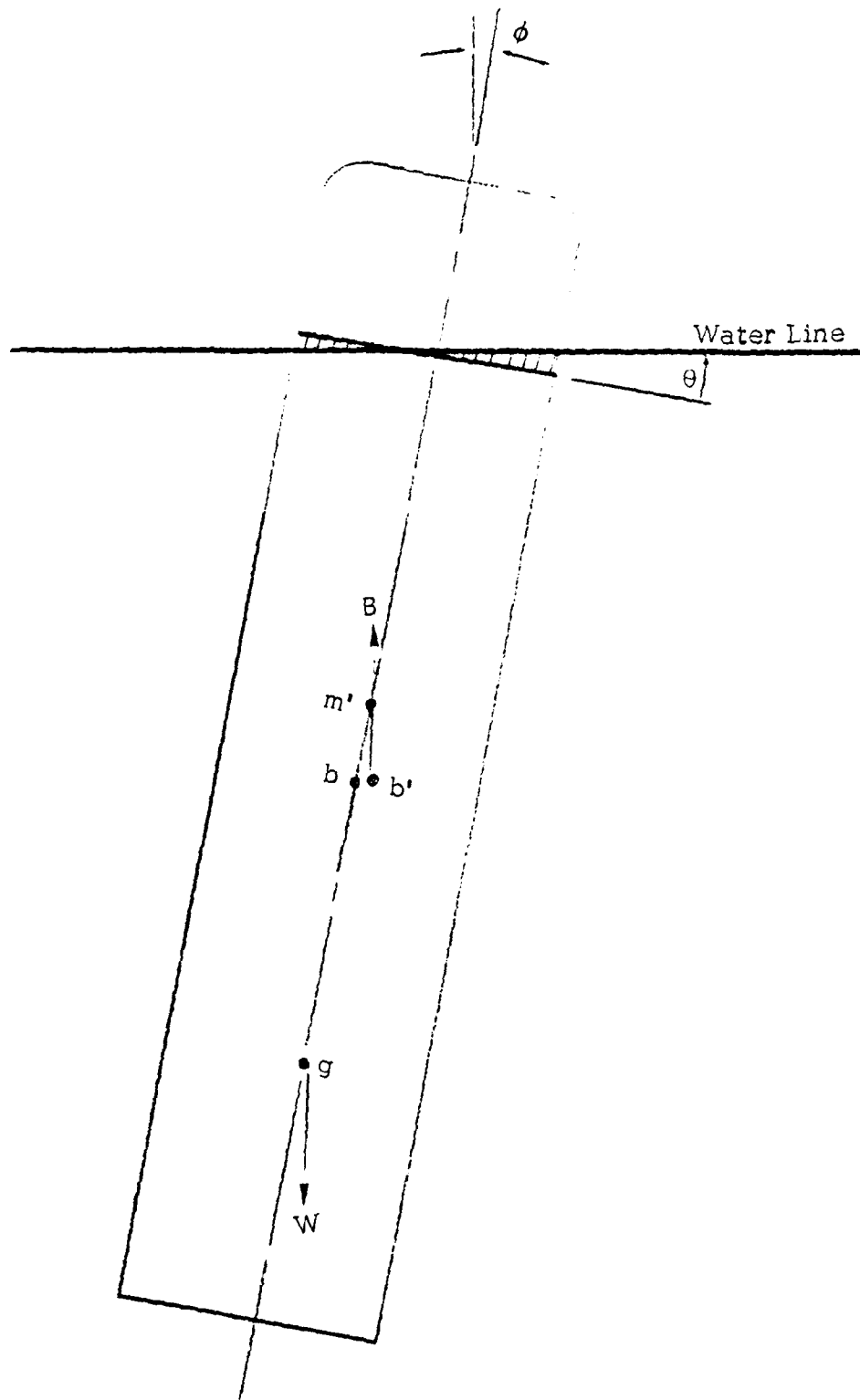

Figure 2-1. Geometry of the Restoring Forces Due to Buoy Tilt

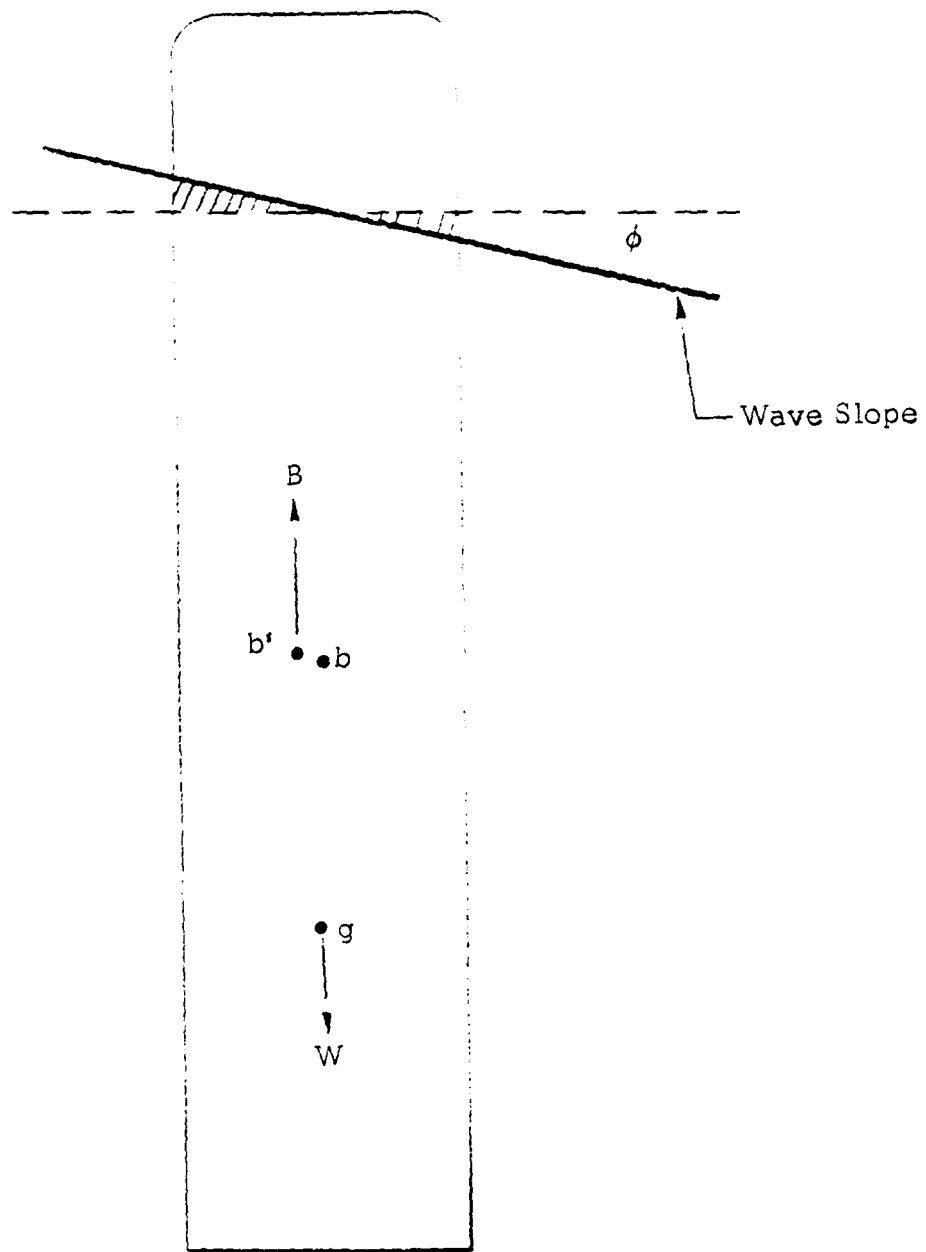

Figure 2-2. Geometry of the Restoring Forces Due to the Wave Slope

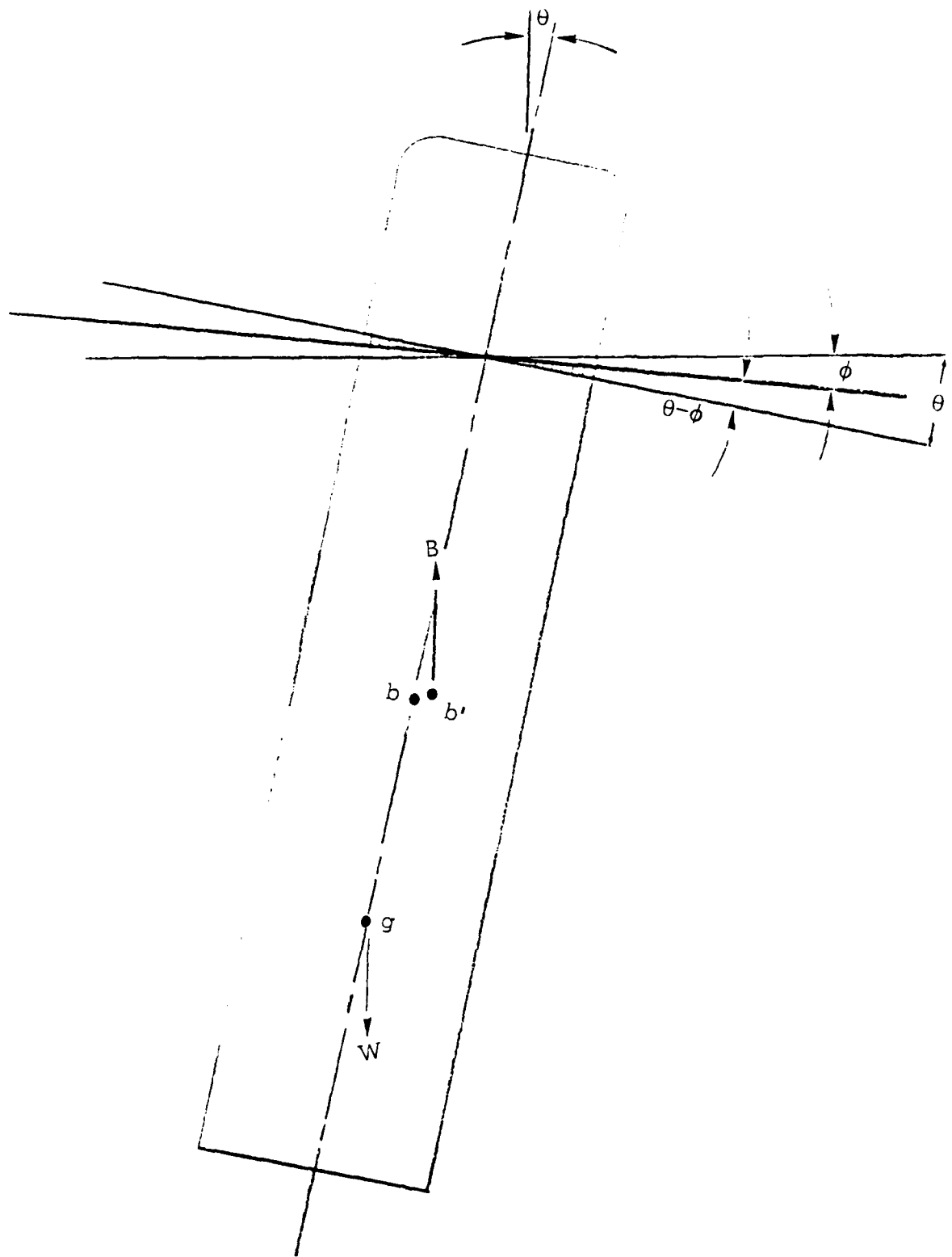

Figure 2-3. Geometry of the Restoring Forces Due to Buoy Tilt and the Wave Slope

$$M = W\overline{gm} \sin (\theta - \varphi)$$

$$M = W\overline{gm} (\theta - \varphi)$$

2.3 EQUATION OF MOTION FOR FREE FLOATING BUOY

The equation of motion for roll oscillations in waves is given by

$$I_v \ddot{\theta} + b_d \dot{\theta} + W\overline{gm} (\theta - \varphi) = 0$$

where I_v is the virtual mass moment of inertia and b_d is the linearized damping coefficient. The wave slope φ can be expressed as

$$\varphi \cong \tan \phi = a \sin \omega t$$

where from the theory of ocean waves

$$a = \frac{\pi H}{L} = \frac{\omega^2 A}{g}$$

The equation of motion can therefore be expressed as

$$I_v \ddot{\theta} + b_d \dot{\theta} + W\overline{gm} \theta = a W\overline{gm} \sin \omega t$$

Simplifying and substituting for constants we get

$$\ddot{\theta} + 2n \dot{\theta} + p^2 \theta = a p^2 \sin \omega t$$

$$2n = \frac{b_d}{I_v}$$

$$p = \sqrt{\frac{W\overline{gm}}{I_v}} \equiv \text{natural frequency}$$

The steady state solution to this equation will be

$$\theta = c_1 \sin \omega t + c_2 \cos \omega t$$

Differentiating we get

$$\dot{\theta} = c_1 \omega \cos \omega t - c_2 \omega \sin \omega t$$

$$\ddot{\theta} = -c_1 \omega^2 \sin \omega t - c_2 \omega^2 \cos \omega t$$

Substituting back into the original equation and equating sine and cosine terms we get:

$$(p^2 - \omega^2) c_1 - 2n\omega c_2 = a p^2$$

$$2n\omega c_1 + (p^2 - \omega^2) c_2 = 0$$

$$c_2 = -\frac{2n\omega}{p^2 - \omega^2} c_1$$

$$(p^2 - \omega^2) c_1 + \frac{(2n\omega)^2}{(p^2 - \omega^2)} c_1 = a p^2$$

$$c_1 = \frac{a p^2 (p^2 - \omega^2)}{(p^2 - \omega^2)^2 + (2n\omega)^2}$$

$$c_2 = \frac{-2n\omega}{(p^2 - \omega^2)} \left[\frac{a p^2 (p^2 - \omega^2)}{(p^2 - \omega^2)^2 + (2n\omega)^2} \right]$$

The solution can be expressed as

$$\theta = \Theta \sin(\omega t - \sigma)$$

where

$$\Theta = \sqrt{c_1^2 + c_2^2}$$

$$\Theta = \tan^{-1} \frac{-c_2}{c_1}$$

$$\Theta = \left\{ \left[\frac{a p^2 (p^2 - \omega^2)}{(p^2 - \omega^2)^2 + (2n\omega)^2} \right]^2 + \frac{(2n\omega)^2}{(p^2 - \omega^2)^2} \left[\frac{a p^2 (p^2 - \omega^2)}{(p^2 - \omega^2)^2 + (2n\omega)^2} \right]^2 \right\}^{1/2}$$

$$\Theta = \frac{a p^2 (p^2 - \omega^2)}{(p^2 - \omega^2)^2 + (2n\omega)^2} \sqrt{1 + \frac{(2n\omega)^2}{(p^2 - \omega^2)^2}}$$

$$\Theta = \frac{\alpha p^2 (p^2 - \omega^2)}{(p^2 - \omega^2)^2 + (2n\omega)^2} \sqrt{\frac{(p^2 - \omega^2)^2 + (2n\omega)^2}{(p^2 - \omega^2)^2}}$$

$$\Theta = \frac{\alpha p^2 (p^2 - \omega^2)}{(p^2 - \omega^2)^2 + (2n\omega)^2} \frac{1}{(p^2 - \omega^2)} \sqrt{(p^2 - \omega^2)^2 + (2n\omega)^2}$$

$$\Theta = \frac{\alpha p^2}{\sqrt{(p^2 - \omega^2)^2 + (2n\omega)^2}}$$

$$\sigma = \tan^{-1} \left(\frac{2n\omega}{p^2 - \omega^2} \right)$$

Therefore the solution is given by

$$\theta = \frac{\alpha p^2}{\sqrt{(p^2 - \omega^2)^2 + (2n\omega)^2}} \sin(\omega t - \sigma)$$

Since

$$\alpha = \frac{\omega^2 A}{g}$$

$$\theta = \frac{\frac{\omega^2}{g} p^2 A}{\sqrt{(p^2 - \omega^2)^2 + (2n\omega)^2}} \sin(\omega t - \sigma)$$

2.4 LINEARIZED DAMPING COEFFICIENT

The differential moment contributed by damping is given by

$$dM = r dF$$

as shown in Figure 2-4. The differential force is given by

$$dF = 1/2 \rho c_D D (r \dot{\theta})^2 dr$$

Therefore, the moment is given by

$$dM = 1/2 \rho c_D D r^3 \dot{\theta}^2 dr$$

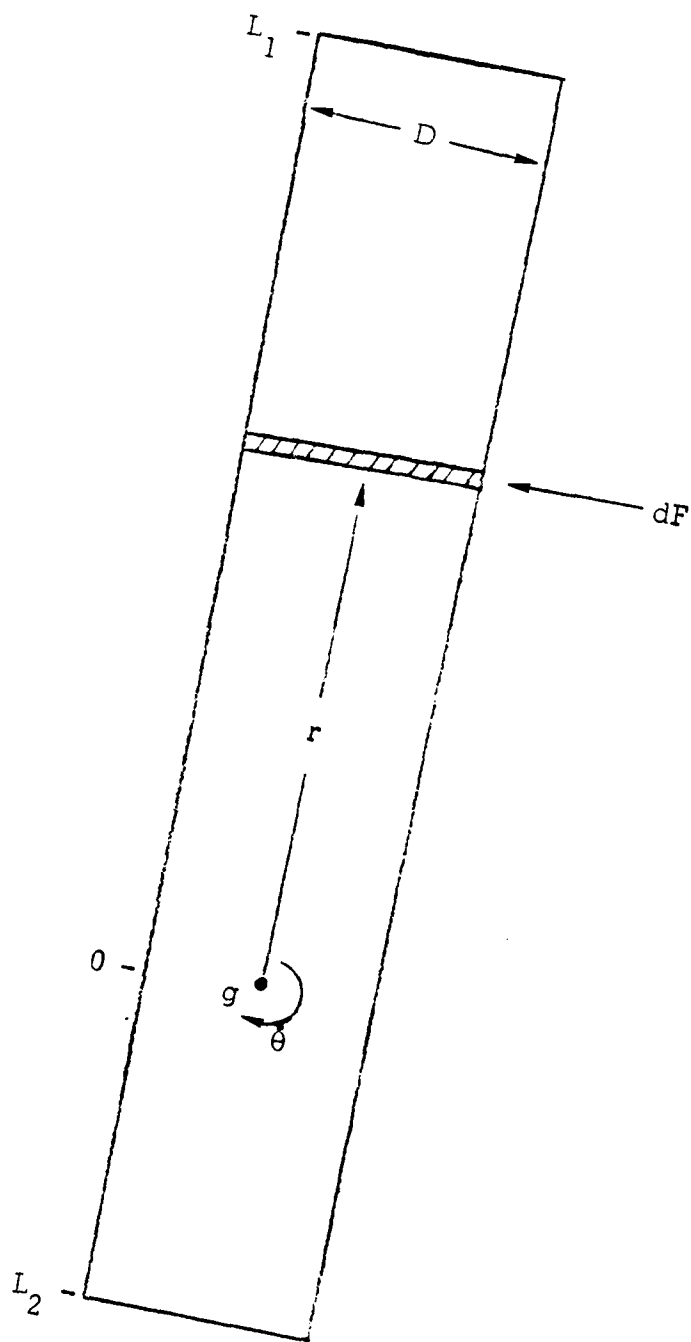

Figure 2-4. Damping Force

Integrating over the length of the submerged cylinder we have

$$M = 1/8 \rho C_D D (\ell_1^4 + \ell_2^4) |\dot{\theta}| \dot{\theta}$$

since

$$\begin{aligned} \theta &= \theta_0 \sin \omega t \\ \dot{\theta} &= \dot{\theta}_0 \omega \cos \omega t \end{aligned}$$

The absolute value of the average angular speed, $\overline{|\dot{\theta}|}$, over one cycle will be

$$\begin{aligned} \overline{|\dot{\theta}|} &= \frac{1}{T} \int_0^T \dot{\theta} dt \\ \overline{|\dot{\theta}|} &= \frac{1}{2\pi} (4) \int_0^{\pi/2} \theta_0 \omega \cos \omega t dt \\ \overline{|\dot{\theta}|} &= \frac{2}{\pi} \theta_0 \omega \sin \omega t \Big|_0^{\pi/2} \\ \overline{|\dot{\theta}|} &= \frac{2\theta_0}{\pi} \end{aligned}$$

Therefore, since the damping moment is

$$M = 1/8 \rho C_D D (\ell_1^4 + \ell_2^4) \overline{|\dot{\theta}|} \dot{\theta}$$

then the linearized damping coefficient is

$$b = 1/8 \rho C_D D (\ell_1^4 + \ell_2^4) |\dot{\theta}| \dot{\theta} \quad .$$

For the following parameters

$$\rho = 1.99 \text{ slugs/ft}^3$$

$$C_D = 1.5$$

$$D = 4.77 \text{ ft}$$

$$l_1 = 15.53 \text{ ft}$$

$$l_2 = 34.47 \text{ ft}$$

$$\theta_o = 0.2 \text{ rad}$$

The damping coefficient is computed to be

$$b = 333,107 \text{ ft-lb-sec}$$

2.5 STATISTICAL ROLL RESPONSE TO OCEAN WAVES EXCITATION

The Response Amplitude Operator (RAO) is the linear response to a simple harmonic wave of unit amplitude.

$$\text{RAO} = Y(\omega) = \frac{\theta}{A}$$

$$Y(\omega) = \frac{\omega^2 p^2}{g \sqrt{(p^2 - \omega^2)^2 + (2 n \omega)^2}}$$

For a wave height spectrum, $S(\omega)$, the root mean square of the response can be obtained from

$$\sqrt{r^2} = \sqrt{R}$$

$$R = \int_0^{\infty} R(\omega) d\omega$$

$$R(\omega) = Y^2(\omega) S(\omega)$$

The Pierson-Moskowitz double height spectrum is given by

$$S_{2H}(\omega) = \frac{135}{\omega^5} e^{-\frac{9.7 \times 10^4}{V_k^4 \omega^4}}$$

where V_k is the sustained wind speed in knots.

Figure 2-5 show the buoy roll RAO, $Y(\omega)$ as a function of frequency. Figure 2-6 shows the Pierson - Moskowitz double height wave spectrum for a wind speed of 30 kts. The roll response spectral density for a 30 kt. wind speed is shown in Figure 2-7. The area under the curve in Figure 2-7 will give the root mean square response of the buoy in roll for the 30 knot wind speed spectrum. The process shown in Figures 2-5 through 2-7 was completed for a range of winds speeds and the results are presented in Figure 2-8. The three waves shown in Figure 2-8 correspond to

- $\bar{\theta}_{1/3}$ the average of the one-third highest roll responses
- $\bar{\theta}$ the average of all roll responses
- θ_m the most probable (frequent) response.

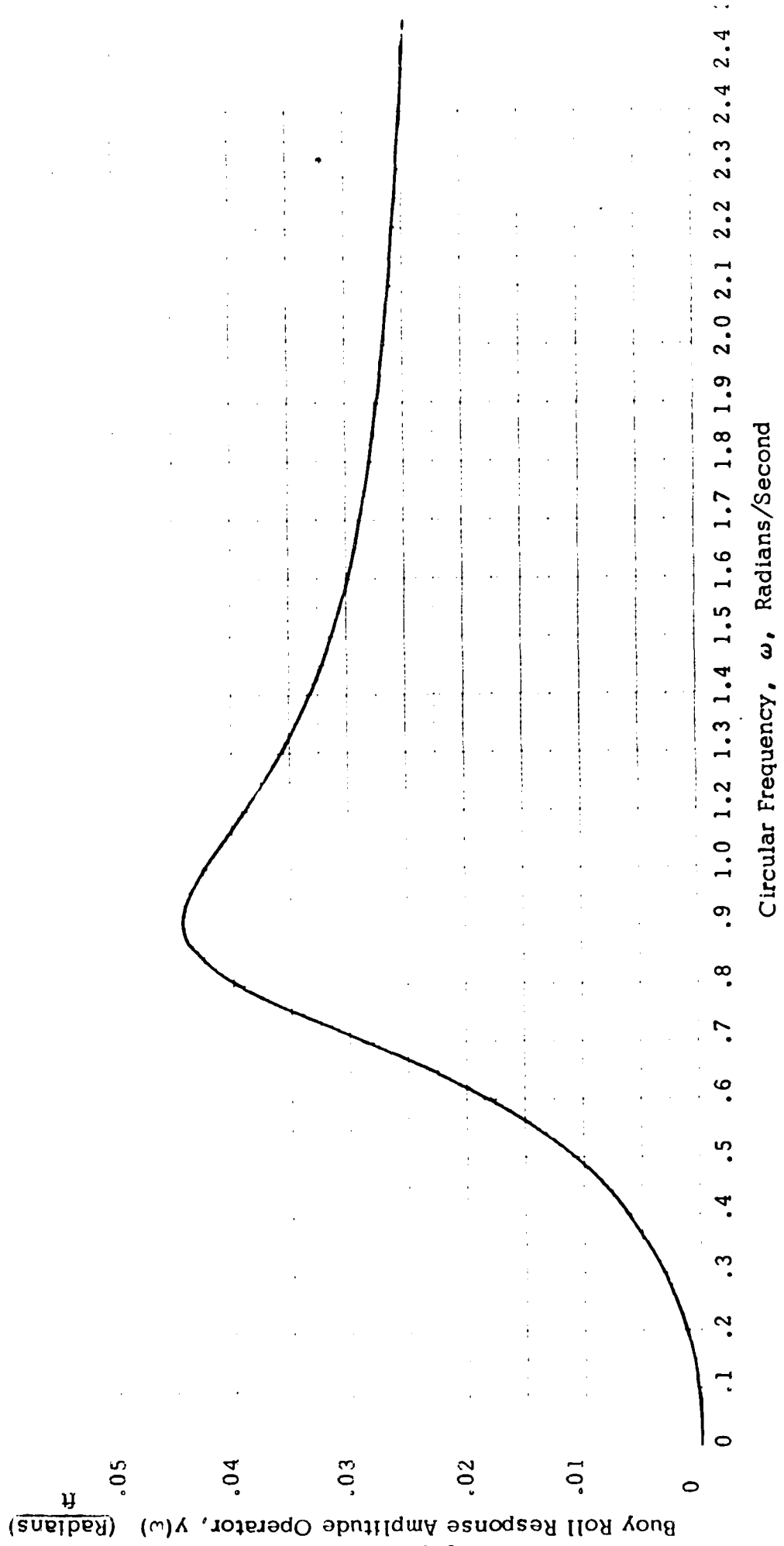

Figure 2-5. PXIE Buoy Roll Response Amplitude Operator

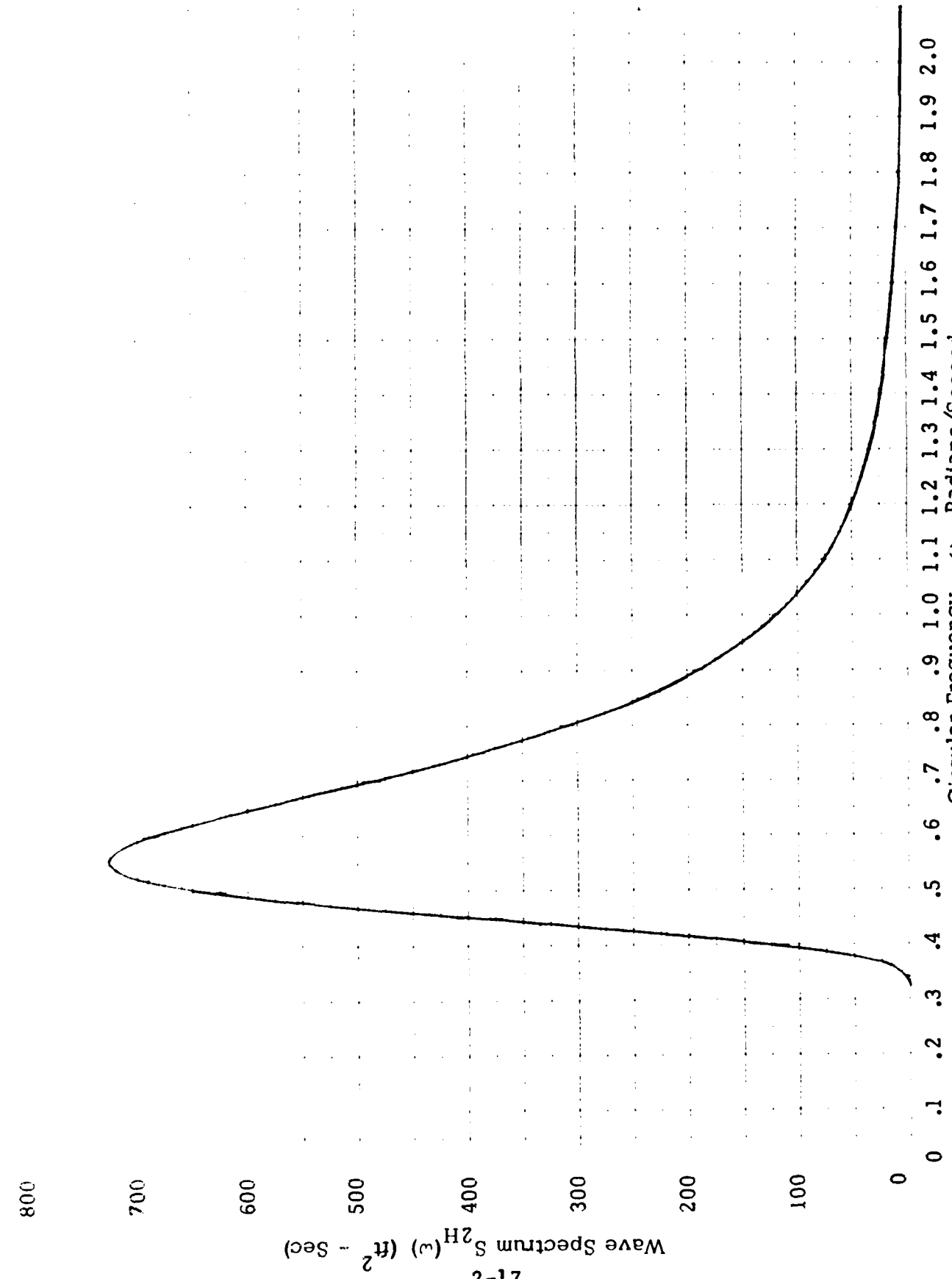

Figure 2-6. Pierson - Moskowitz Double Height Spectrum for a 30-knot Wind Speed

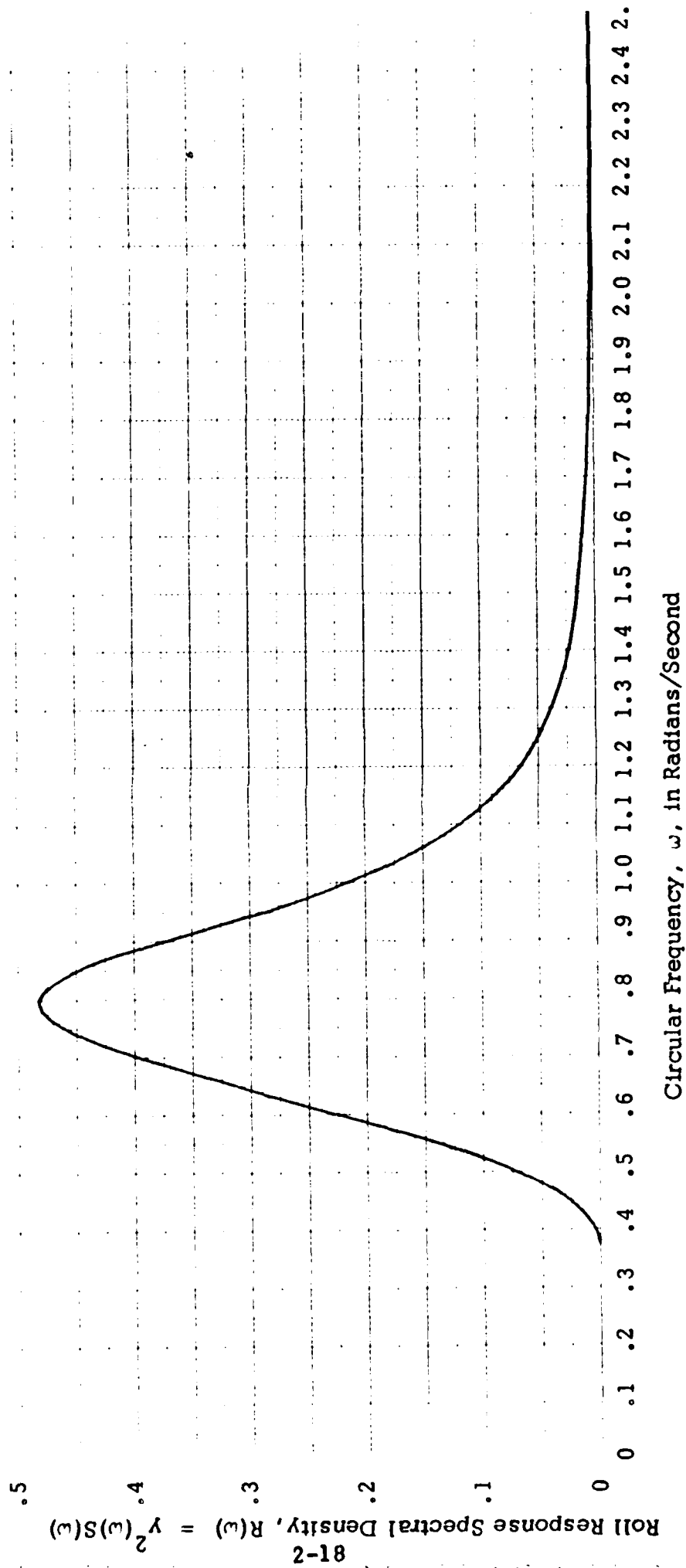

Figure 2-7. Roll Response Spectrum for a 30-knot Wind Speed Wave Height Spectrum

61-2

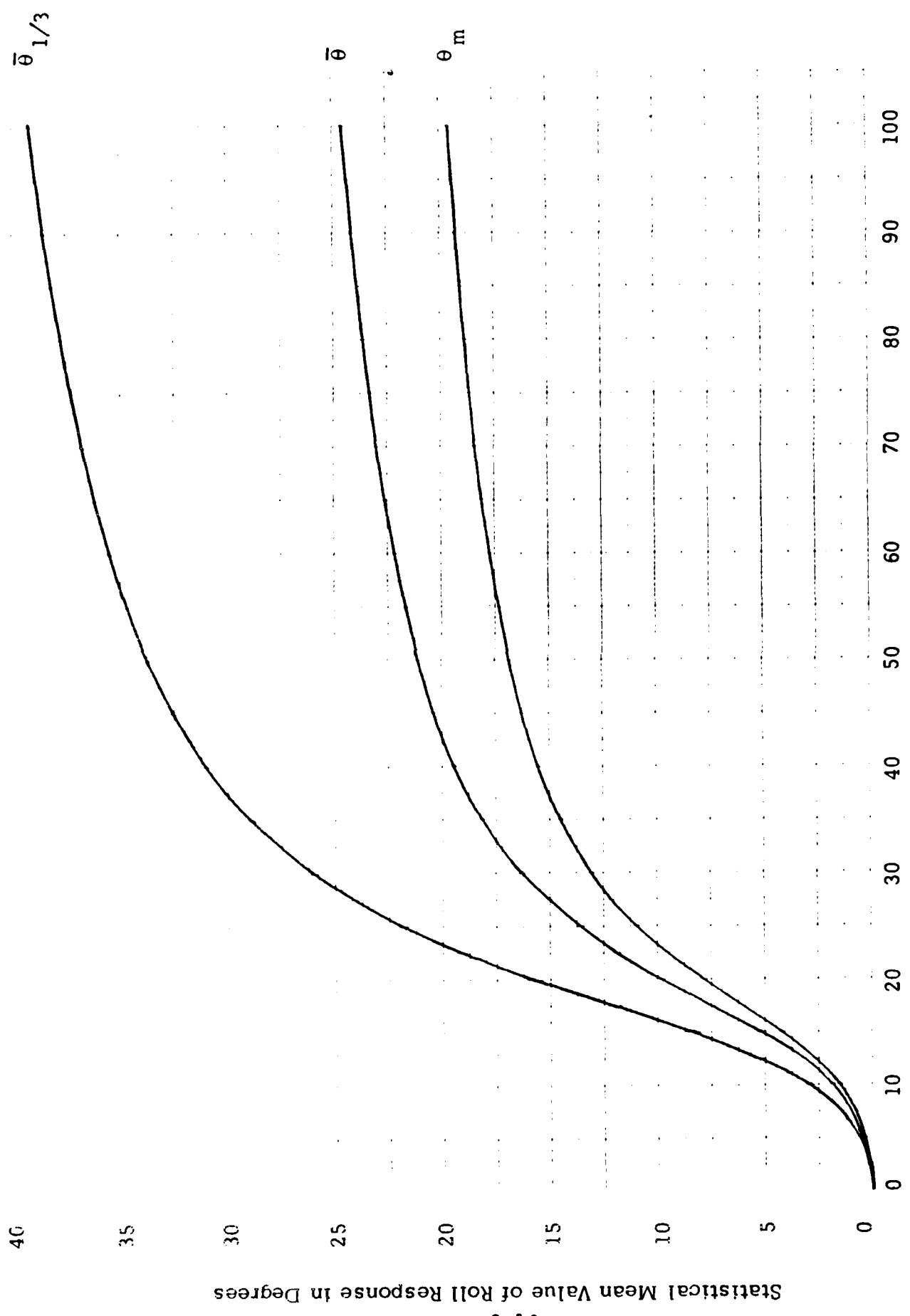

Figure 2-8. Mean Roll Response as a Function of Wind Speed

Section 3

DYNAMICS OF MOORED BUOY

3.1 RESTORING MOMENT

The restoring moment as illustrated in Figure 3-1 is given by

$$M = (B + \Delta B) \overline{gm} (\theta - \varphi) + T_y L_w \theta - D_o \left(\frac{L_o + H}{2} - L_w \right) - T_x L_w$$

where,

$$\overline{gm} = \frac{(L_B - L_w) B + \left(L_o + \frac{H}{2} - L_w \right) \Delta B}{B + \Delta B} + \frac{I_{wp}}{\Delta B}$$

$$\overline{gm} = \frac{(L_B - L_w) B + \left(L_o + \frac{H}{2} - L_w \right) \Delta B}{B + \Delta B} + \frac{I_{wp} \gamma}{B + \Delta B}$$

$$M = \left[(L_B - L_w) B + \left(L_o + \frac{H}{2} - L_w \right) \Delta B + \gamma I_{wp} \right] (\theta - \varphi) + T_y L_w \theta - D_o \left(\frac{L_o + H}{2} - L_w \right) - T_x L_w$$

$$M = \left[(L_B - L_w) B + \left(L_o + \frac{H}{2} - L_w \right) \Delta B + \gamma I_{wp} \right] \theta - \left[(L_B - L_w) B + \left(L_o + \frac{H}{2} - L_w \right) \Delta B + \gamma I_{wp} \right] \varphi + T_y L_w \theta - D_o \left(\frac{L_o + H}{2} - L_w \right) - T_x L_w$$

The angle θ is the sum of the steady state and time varying angles, θ_o and $\theta(t)$

$$\begin{aligned} \theta &= \theta_o + \theta(t) = \theta_o + \Theta \sin(\omega t - \sigma) \\ \dot{\theta} &= \dot{\theta}(t) = \Theta \omega \cos(\omega t - \sigma) \\ \ddot{\theta} &= \ddot{\theta}(t) = -\Theta \omega^2 \sin(\omega t - \sigma) \end{aligned}$$

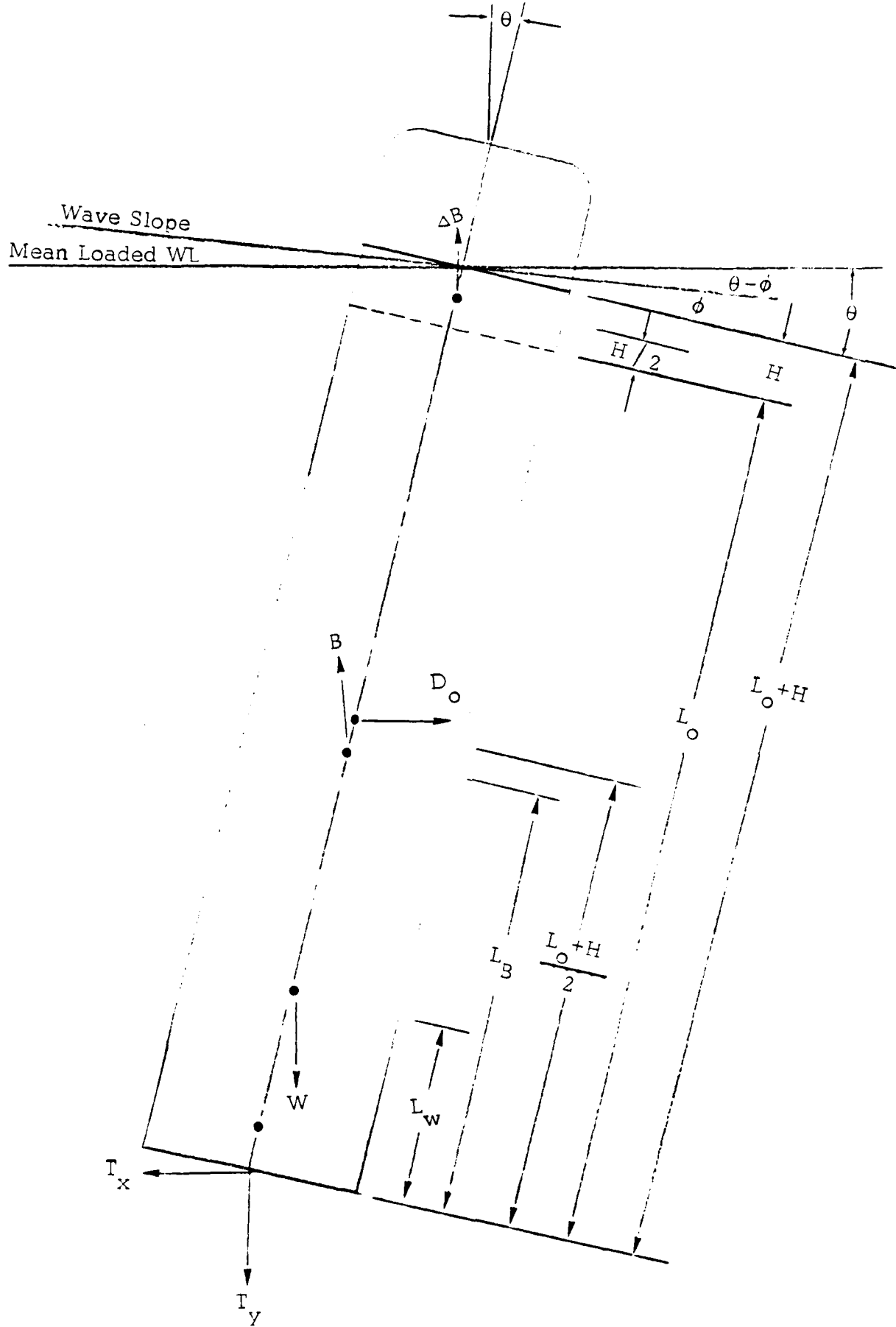

Figure 3-1. Moored Buoy Force Diagram
3-2

$$\begin{aligned}
M = & \left[(L_B - L_w) B + \left(L_o + \frac{H}{2} - L_w \right) \Delta B + \gamma I_{wp} + T_y L_w \right] \theta_o \\
& + \left[(L_B - L_w) B + \left(L_o + \frac{H}{2} - L_w \right) \Delta B + \gamma I_{wp} + T_y L_w \right] \theta(t) \\
& - \left[(L_B - L_w) B + \left(L_o + \frac{H}{2} - L_w \right) \Delta B + \gamma I_{wp} \right] \phi \\
& - D_o \left(\frac{L_o + H}{2} - L_w \right) - T_x L_w
\end{aligned}$$

The steady state pitch angle, θ_o , is given by

$$\theta_o \cong \sin \theta_o = \left[\frac{D_o \left(\frac{L_o + H}{2} \right)}{B L_B + \Delta B \left(L_o + \frac{H}{2} \right) - W L_w} \right]$$

$$M = \left[(L_B - L_w) B + \left(L_o + \frac{H}{2} - L_w \right) \Delta B + \gamma I_{wp} + T_y L_w \right] \left[\frac{D_o \left(\frac{L_o + H}{2} \right)}{B L_B + \Delta B \left(L_o + \frac{H}{2} \right) - W L_w} \right]$$

$$+ \left[(B + \Delta B) \bar{g}_m + T_y L_w \right] \theta(t) - (B + \Delta B) \bar{g}_m \phi$$

$$- D_o \left(\frac{L_o + H}{2} \right)$$

$$M = \left[(L_B - L_w) B + \left(L_o + \frac{H}{2} \right) \Delta B + \gamma I_{wp} \right] \left[\frac{D_o \left(\frac{L_o + H}{2} \right)}{B(L_B - L_w) + \Delta B \left(L_o + \frac{H}{2} \right)} \right]$$

$$+ \left[(B + \Delta B) \bar{g}_m + T_y L_w \right] \theta(t) - (B + \Delta B) \bar{g}_m \phi$$

$$- D_o \left(\frac{L_o + H}{2} \right)$$

$$M = \left[1 + \frac{\gamma I_{wp}}{B(L_B - L_w) + \Delta B \left(L_o + \frac{H}{2} \right)} \right] D_o \left(\frac{L_o + H}{2} \right) \\ + \left[(B + \Delta B) \overline{g\bar{m}} + T_y L_w \right] \theta(t) - (B + \Delta B) \overline{g\bar{m}} \phi \\ - D_o \left(\frac{L_o + H}{2} \right)$$

$$M = \left[(B + \Delta B) \overline{g\bar{m}} + T_y L_w \right] \theta(t) - (B + \Delta B) \overline{g\bar{m}} \phi$$

∴ The moments due to the steady state drag and the horizontal component of tension for a steady state tilt angle, θ_o , cancel each other out.

This assumes that

$$D = D_o + D(t)$$

$$\frac{dD}{dt} = \frac{dD(t)}{dt} = b\dot{\theta}$$

and that the mooring line spring constant in the horizontal direction is zero, i.e.

$$T_x(\theta) = K L_w \theta$$

$$K = 0$$

$$T_x(\theta) = 0$$

3.2 EQUATION OF MOTION

The equation of motion is given by

$$I_V \ddot{\theta} + b_d \dot{\theta} + [(B + \Delta B) \overline{gm} + T_Y L_W] \theta(t) = (B + \Delta B) \overline{gm} \phi$$

$$\phi = \alpha \sin \omega t$$

$$\alpha = \frac{\pi H}{L} = \frac{\omega^2}{g} A$$

$$B + \Delta B = W + T_Y$$

$$\ddot{\theta} + \frac{b_d}{I_V} \dot{\theta} + \left[\frac{(W + T_Y) \overline{gm} + T_Y L_W}{I_V} \right] \theta(t) = \frac{(W + T_Y) \overline{gm}}{I_V} \alpha \sin \omega t$$

$$\ddot{\theta} + a\dot{\theta} + b\theta = c \sin \omega t$$

$$a = \frac{b_d}{I_V}$$

$$b = \frac{(W + T_Y) \overline{gm} + T_Y L_W}{I_V}$$

$$c = \frac{(W + T_Y) \overline{gm}}{I_V} \frac{\omega^2}{g} A$$

The steady state solution is given by

$$\theta = c_1 \sin \omega t + c_2 \cos \omega t$$

Differentiating we get

$$\dot{\theta} = c_1 \omega \cos \omega t - c_2 \omega \sin \omega t$$

$$\ddot{\theta} = c_1 \omega^2 \sin \omega t - c_2 \omega^2 \cos \omega t$$

Substituting back into the original equation,

$$\begin{aligned} -c_1 \omega^2 \sin \omega t - c_2 \omega^2 \cos \omega t + a c_1 \omega \cos \omega t - a c_2 \omega \sin \omega t \\ + b c_1 \sin \omega t + b c_2 \cos \omega t = c \sin \omega t \end{aligned}$$

Equating coefficients of sine and cosine terms,

$$-c_1 \omega^2 - a c_2 \omega + b c_1 = c$$

$$-c_2 \omega^2 + a c_1 \omega + b c_2 = 0$$

$$(b - \omega^2) c_1 - a \omega c_2 = c$$

$$a \omega c_1 + (b - \omega^2) c_2 = 0$$

$$c_2 = \frac{-a \omega}{b - \omega^2} c_1$$

$$(b - \omega^2) c_1 + \frac{(a \omega)^2}{b - \omega^2} c_1 = c$$

$$\frac{(b - \omega^2)^2 + (a \omega)^2}{b - \omega^2} c_1 = c$$

$$c_1 = \frac{c (b - \omega^2)}{(b - \omega^2)^2 + (a \omega)^2}$$

$$\theta = \sqrt{c_1^2 + c_2^2} \sin(\omega t - \alpha)$$

$$\alpha = \tan^{-1} \left(\frac{c_2}{c_1} \right)$$

$$\Theta = \left\{ \left[\frac{c(b-\omega^2)}{(b-\omega^2)^2 + (a\omega)^2} \right]^2 + \frac{(a\omega)^2}{(b-\omega^2)^2} \left[\frac{c(b-\omega^2)}{(b-\omega^2)^2 + (a\omega)^2} \right]^2 \right\}^{1/2}$$

$$\Theta = \left(\frac{c(b-\omega^2)}{(b-\omega^2)^2 + (a\omega)^2} \right) \sqrt{1 + \frac{(a\omega)^2}{(b-\omega^2)^2}}$$

$$\Theta = \frac{c(b-\omega^2)}{(b-\omega^2)^2 + (a\omega)^2} \sqrt{\frac{(b-\omega^2)^2 + (a\omega)^2}{(b-\omega^2)^2}}$$

$$\Theta = \frac{c(b-\omega^2)}{(b-\omega^2)^2 + (a\omega)^2} \cdot \frac{1}{(b-\omega^2)} \sqrt{(b-\omega^2)^2 + (a\omega)^2}$$

$$\Theta = \frac{c}{\sqrt{(b-\omega^2)^2 + (a\omega)^2}}$$

3.3 RESPONSE TO SPECTRUM

The Response Amplitude Operator is given by,

$$Y(\omega) = \text{RAO} = \frac{\Theta}{A}$$

$$Y(\omega) = \frac{\frac{(w+T_y) \overline{gm} \omega^2}{g I_v}}{\sqrt{\left(\frac{(w+T_y) \overline{gm} + T_y L_w}{I_v} - \omega^2 \right)^2 + \left(\frac{b_d \omega}{I_v} \right)^2}}$$

The Pierson-Moskowitz double wave height spectrum is given by

$$S(\omega) = \frac{135}{\omega^5} e^{-\frac{9.7 \times 10^4}{V_k^4 \omega^4}}$$

The response spectral density is given by

$$R(\omega) = Y^2(\omega) S(\omega)$$

$$R(\omega) = \frac{(W + T_y)^2 \bar{g}m^2 135}{\omega g^2 I_v^2 \left[\left(\frac{(W + T_y) \bar{g}m + T_y L_w}{I_v} - \omega^2 \right)^2 + \left(\frac{b_d}{I_v} \right)^2 \right]} e^{-\frac{9.7 \times 10^4}{V_k^4 \omega^4}}$$

$$R = \int_0^{\infty} R(\omega) d\omega$$

$$\sqrt{r^2} = \sqrt{R}$$

In order to evaluate these functions it is first necessary to relate several **mechanical** parameters to the buoy submergence term, H, since the buoy is no longer considered freely floating. The parameters which must be computed are the new virtual mass moment of inertia, the new linearized damping coefficient, and the effective metacentric height.

Calculate new virtual mass moment of inertia

$$I_{v \text{ new}} = I_{\text{new}} + I'_{\text{new}}$$

$$I_{\text{new}} = I_{\text{old}} = 226,797 \text{ ft-lb-sec}^2$$

$$I'_{\text{new}} = I'_{\text{old}} + (\Delta I' + \Delta M_{\omega} d_{\omega}^2)$$

$$I'_{\text{new}} = I'_{\text{old}} + \frac{\rho g \left(\pi \frac{D^2}{4} H \right)}{g} \left[\left(\frac{D^2}{16} + \frac{H^2}{12} \right) + \left(L_o + \frac{H}{2} - L_w \right)^2 \right]$$

$$I'_{\text{new}} = 531,577 \text{ ft-lb-sec}^2 + 35.56 H \left[1.42 + \frac{H^2}{12} + \left(34.47 + \frac{H}{2} \right)^2 \right]$$

Calculate new linearized damping coefficient, b_d

$$b_d = \frac{1}{4} \frac{\theta_o}{\pi} \rho C_D D \left(L_w^4 + (L_o - L_w + H)^4 \right)$$

$$L_w = 15.53 \text{ ft}$$

$$L_o = 50 \text{ ft}$$

$$D = 4.77 \text{ ft}$$

$$C_D = 1.5$$

$$\rho = 1.99 \frac{\text{lb-sec}^2}{\text{ft}^4}$$

$$\theta_o = 0.2 \text{ rad}$$

$$b_d = \frac{1}{4} \frac{0.2}{\pi} (1.99) (1.5) (4.77) \left[(15.53)^4 + (50 - 15.53 + H)^4 \right]$$

$$b_d = 0.227 \left[58,168 + (34.47 + H)^4 \right]$$

Calculate new Metacentric Height

$$\overline{gm} = \frac{(L_B - L_w) B + (L_o + \frac{H}{2} - L_w) \Delta B}{B + \Delta B} + \frac{I_{wp}}{\pi \frac{D^2}{4} (L_o + H)}$$

$$gm = \frac{(24.99 - 15.53) (57169) + (50 + \frac{H}{2} - 15.53) \Delta B}{57169 + \Delta B} + \frac{25.41}{\frac{\pi (4.77)^2}{4} (50 + H)}$$

$$\overline{gm} = \frac{540819 + (34.47 + \frac{H}{2}) \Delta B}{57169 + \Delta B} + \frac{25.41}{17.87 (50 + H)}$$

If the following mooring configuration is assumed

- 1.0 knot surface current profile
- 2080 ft scope
- 2 ft buoy submergence, H
- 1.9 degree steady state pitch, θ_0

then the following parameters can be calculated to be

$$\Delta B = T_y = 2290 \text{ lbs}$$

$$I_v = 848,047 \text{ ft-lb-sec}^2$$

$$b_d = 414,072 \text{ ft-lb-sec}$$

$$\overline{gm} = 10.49 \text{ ft}$$

Using the above values, the Roll Response Amplitude Operator, $Y(\omega)$ can be determined and is shown in Figure 3-2. The Pierson Moskowitz double wave height spectrum for a 30 knot wind speed is shown in Figure 3-3. Figure 3-4 shows the roll response spectral density to the 30 knot wave spectrum. Figure 3-5 shows the statistical mean roll response as a function of wind speed.

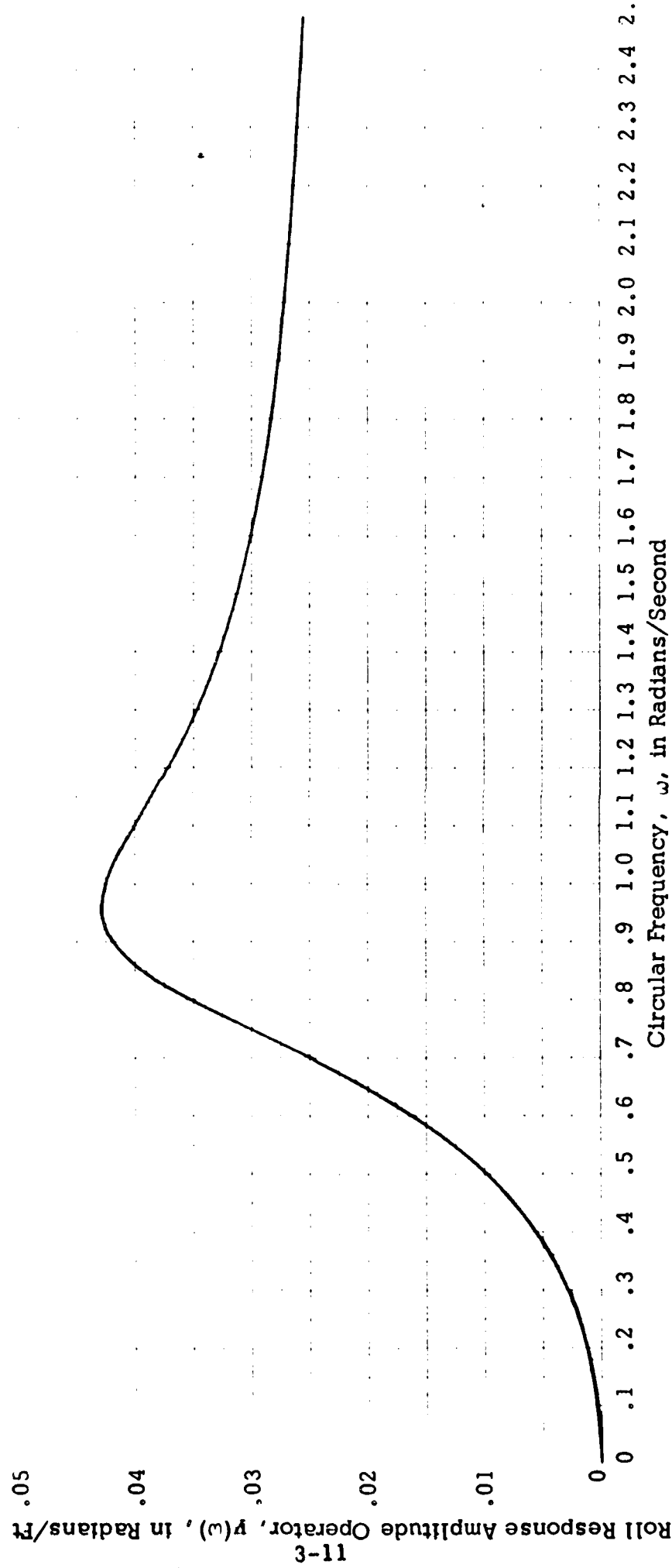

Figure 3-2. Roll Response Amplitude Operator for a Moored PXIE Buoy

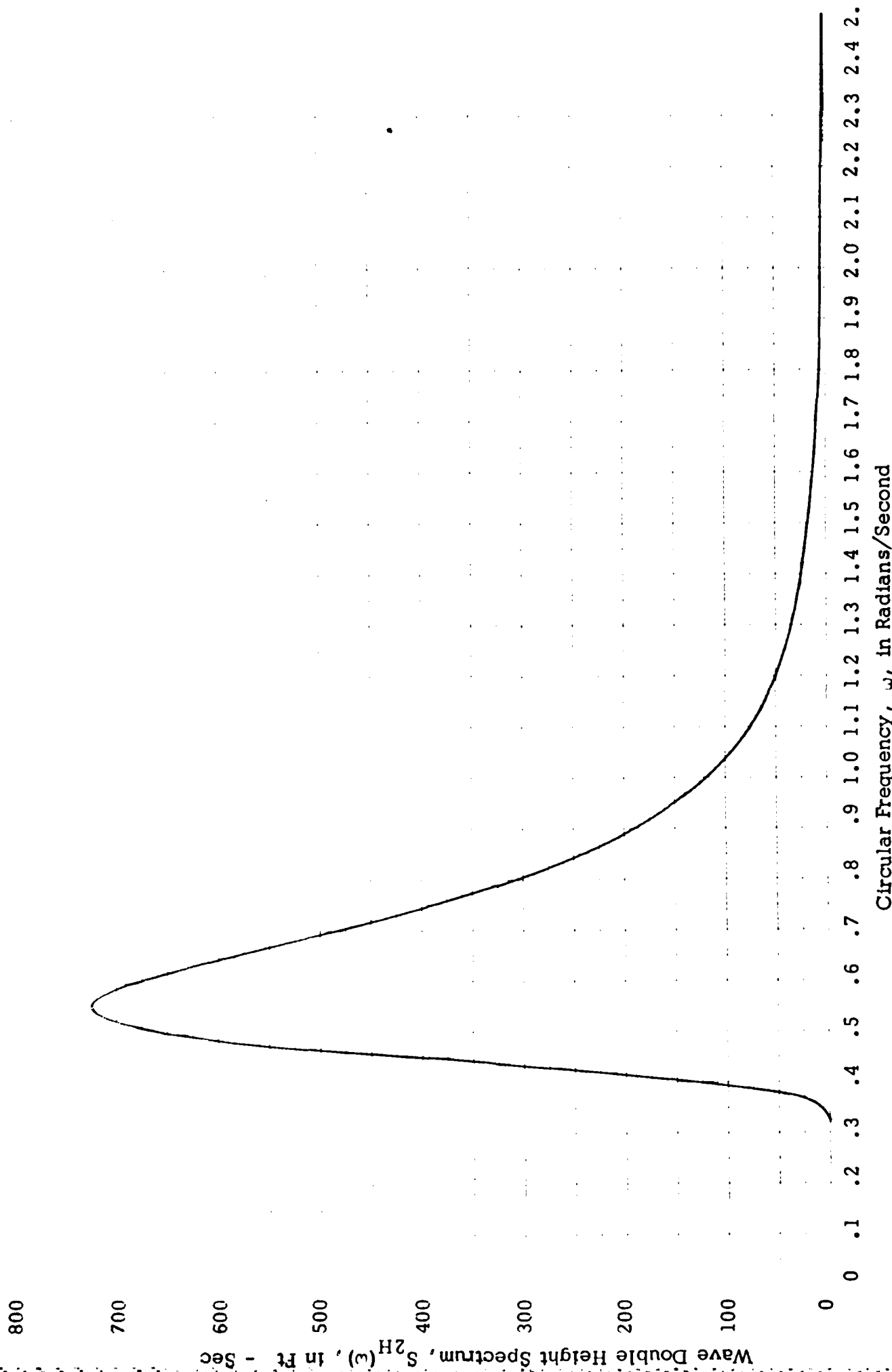

Figure 3-3. Pierson - Moskowitz Double Wave Height Spectrum for a Typical 30 Knot Wind Speed as a Function of Frequency

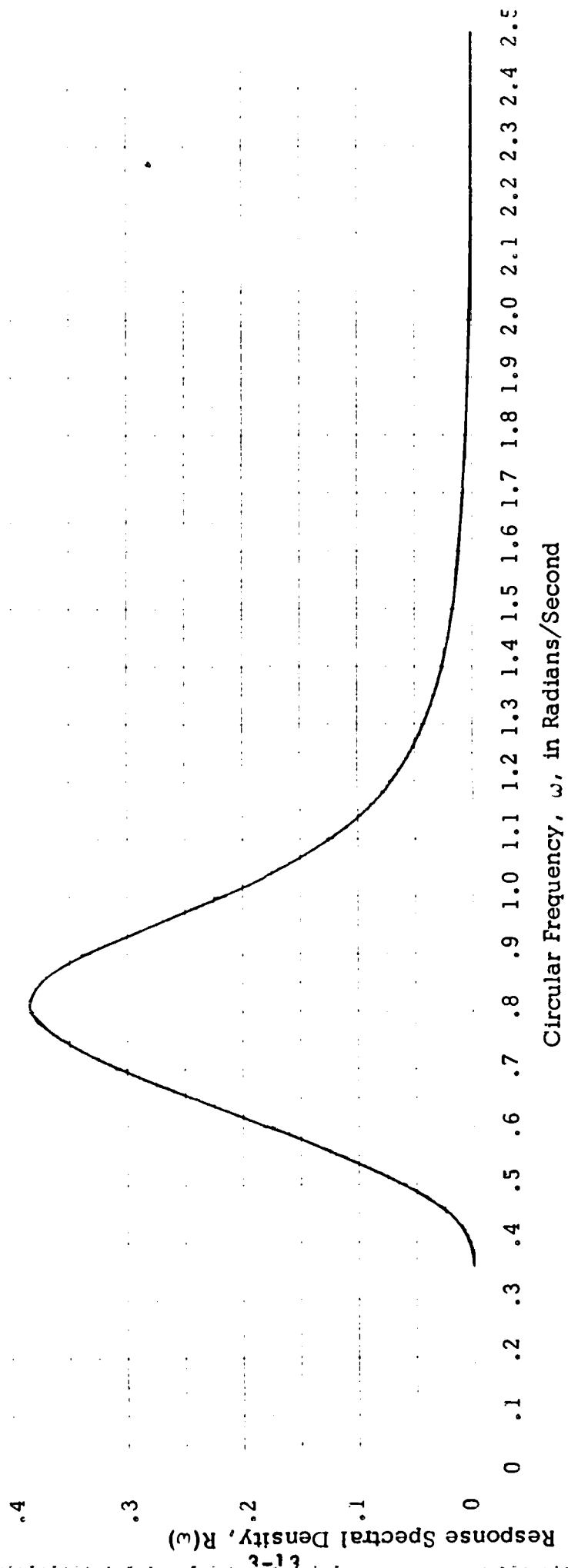

Figure 3-4. Moored PIXIE Buoy Roll Response Spectrum for a 30-knot Wind Speed
Wave Height Spectrum

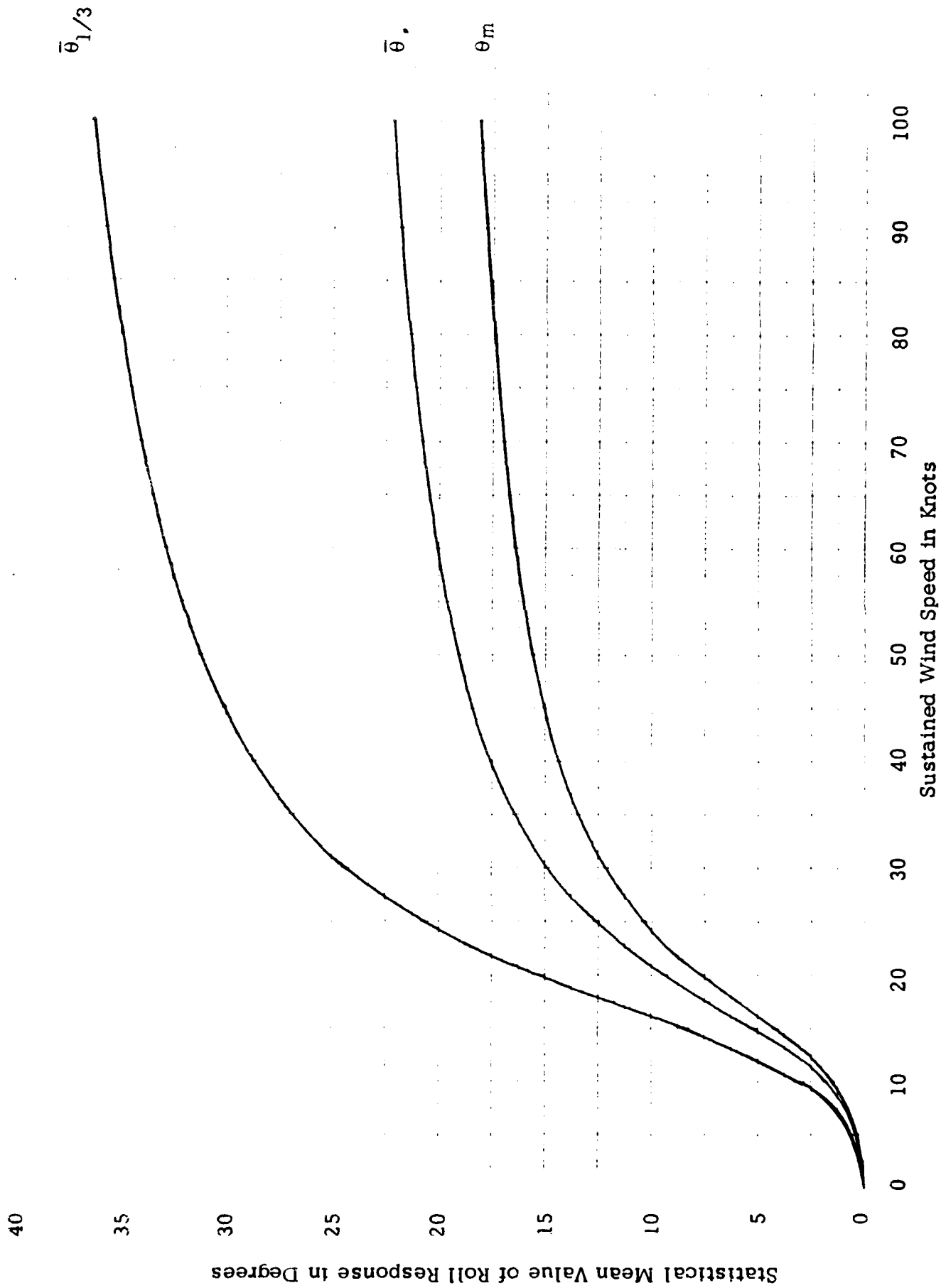

Figure 3-5. Moored Buoy Mean Roll Response as a Function of Wind Speed

END
DTIC
FILMED
4-86