

AD-A165 603

APPARATUS FOR THE PREPARATION OF AIR(U) FOREIGN

1/1

TECHNOLOGY DIV WRIGHT-PATTERSON AFB OH

N S NIKOLAYEV ET AL. 12 MAR 86 FTD-ID(R5)T-8134-86

UNCLASSIFIED

F/G 13/7

NL



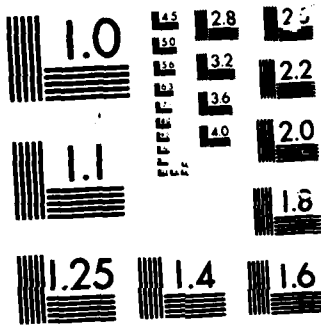

MICROCOPY RESOLUTION TEST CHART

2

FTD-ID(RS)T-0134-86

AD-A165 603

FOREIGN TECHNOLOGY DIVISION



DTIC
ELECTE
MAR 25 1986
S D

APPARATUS FOR THE PREPARATION OF AIR

by

N.S. Nikolayev, Ya. M. Itskovich, et al.



DTIC FILE COPY

Approved for public release;
Distribution unlimited.



EDITED TRANSLATION

FTD-ID(RS)T-0134-86

12 Mar 86

MICROFICHE NR: FTD-86-C-001603

APPARATUS FOR THE PREPARATION OF AIR

By: N.S. Nikolayev, Ya. M. Itskovich, et al.

English pages: 7

Source: USSR Patent Nr. 302279, 28 April 1971, pp. 1-3

Country of origin: USSR

Translated by: Robert D. Hill

Requester: AF/JACPD

Approved for public release; Distribution unlimited.

THIS TRANSLATION IS A RENDITION OF THE ORIGINAL FOREIGN TEXT WITHOUT ANY ANALYTICAL OR EDITORIAL COMMENT. STATEMENTS OR THEORIES ADVOCATED OR IMPLIED ARE THOSE OF THE SOURCE AND DO NOT NECESSARILY REFLECT THE POSITION OR OPINION OF THE FOREIGN TECHNOLOGY DIVISION.

PREPARED BY:

TRANSLATION DIVISION
FOREIGN TECHNOLOGY DIVISION
WP-AFB, OHIO.

FTD -ID(RS)T-0134-86

Date 12 Mar 19 86



1800
US
SI
A-1

U. S. BOARD ON GEOGRAPHIC NAMES TRANSLITERATION SYSTEM

Block	Italic	Transliteration	Block	Italic	Transliteration
А а	<i>А а</i>	A, a	Р р	<i>Р р</i>	R, r
Б б	<i>Б б</i>	B, b	С с	<i>С с</i>	S, s
В в	<i>В в</i>	V, v	Т т	<i>Т т</i>	T, t
Г г	<i>Г г</i>	G, g	У у	<i>У у</i>	U, u
Д д	<i>Д д</i>	D, d	Ф ф	<i>Ф ф</i>	F, f
Е е	<i>Е е</i>	Ye, ye; E, e*	Х х	<i>Х х</i>	Kh, kh
Ж ж	<i>Ж ж</i>	Zh, zh	Ц ц	<i>Ц ц</i>	Ts, ts
З з	<i>З з</i>	Z, z	Ч ч	<i>Ч ч</i>	Ch, ch
И и	<i>И и</i>	I, i	Ш ш	<i>Ш ш</i>	Sh, sh
Й й	<i>Й й</i>	Y, y	Щ щ	<i>Щ щ</i>	Shch, shch
К к	<i>К к</i>	K, k	Ъ ъ	<i>Ъ ъ</i>	"
Л л	<i>Л л</i>	L, l	Ы ы	<i>Ы ы</i>	Y, y
М м	<i>М м</i>	M, m	Ь ь	<i>Ь ь</i>	'
Н н	<i>Н н</i>	N, n	Э э	<i>Э э</i>	E, e
О о	<i>О о</i>	O, o	Ю ю	<i>Ю ю</i>	Yu, yu
П п	<i>П п</i>	P, p	Я я	<i>Я я</i>	Ya, ya

*ye initially, after vowels, and after ъ, ь; e elsewhere.
When written as ë in Russian, transliterate as yë or ë.

RUSSIAN AND ENGLISH TRIGONOMETRIC FUNCTIONS

Russian	English	Russian	English	Russian	English
sin	sin	sh	sinh	arc sh	sinh ⁻¹
cos	cos	ch	cosh	arc ch	cosh ⁻¹
tg	tan	th	tanh	arc th	tanh ⁻¹
ctg	cot	cth	coth	arc cth	coth ⁻¹
sec	sec	sch	sech	arc sch	sech ⁻¹
cosec	csc	csch	csch	arc csch	csch ⁻¹

Russian English

rot curl
lg log

GRAPHICS DISCLAIMER

All figures, graphics, tables, equations, etc. merged into this translation were extracted from the best quality copy available.

APPARATUS FOR THE PREPARATION OF AIR

Authors of the invention: N. S. Nikolayev, Ya. M. Itskovich, A. V. Shcherbakov, T. V. Stoyanova, and V. V. Golovin

The invention deals with equipment for ensuring the maximal reliable operation of devices of pneumatic control of air conditioning systems, and it can be used, in particular, in an apparatus for preparing air for devices of pneumatic control, for example, air conditioning on aircraft.

Known are apparatuses for air preparation which contain a feed system with air bleed from the main line of the conditioning system, a regulator of excess pressure, which ensures the maintaining of the assigned pressure, an air drier, air filter, and shut-off and regulating equipment. (Translations USSR Russian Language)

In these apparatuses the feed system is fulfilled in the form of one line, and its malfunction leads to the switching off of the entire system of pneumatic control. Furthermore, these apparatuses have no vacuum system, which is necessary for creating a vacuum in

the defined modes in cavities of the appropriate devices of pneumatic control. This results in a considerable lowering of the reliability of operation of the devices.

The purpose of the invention is to provide feed to devices of the pneumatic control in ground operating conditions of the conditioning system.

This is achieved by the fact^{that} the apparatus is equipped with a vacuum line with ejectors installed in parallel in it, which are connected to the feed line by means of a pneumatic valve controllable via the pressure differential between the hermetically sealed cabin and the intake atmosphere introduced into the apparatus by a safeguard automaton.

A diagram of the proposed device is given on the drawing.

The apparatus contains a feed system in the form of lines 1 and 2 duplicating one another with air bleed from the main line of the conditioning system, for example, from the engines. Installed in series in these lines along the air flow are the air-cooled radiators 3 and 4 with injectors 5 and 6 for a suction hole of the blowing air, regulators 7 and 8 of excess pressure, which ensure the maintaining of the assigned pressure, safety valves 9 and 10, air driers 11 and

12, and air filters 13 and 14. Connected between lines 1 and 2 after the air filters 13 and 14, along the air flow in parallel by means of pipelines 15, are units 16 of check valves, the outputs of which through pipelines 17 are connected to cavities of the appropriate devices of the pneumatic control.

Tapped from each feed line are two parallel lines 18 and 19 of pipelines to the vacuum system, equipped in which is an apparatus with ejectors 20, connected through pipelines 21 to output cavities of appropriate devices of pneumatic control, and a vacuum unit 22 of check valves connected through pipeline 23 to the output of the control unit of the pressure regulator. Each of the lines 18 and 19 is connected to one of lines 1 or 2 by means of pneumatic valve 24 or 25, pneumatically connected by pipelines 24 and 25, pneumatically connected by pipelines 26 and 27 with one of the units 16 of check valves of the feed system. Pneumatic valves 24 and 25 by means of pneumatic line 28 are controlled by the safeguard automaton 29 connected to the same unit of check valves of the power feed system.

The apparatus operates in the following way. The air from the conditioning system enters into lines 1 and 2 and is cooled in the air-cooled radiators 3 and 4. Used as the scavenging air in the radiators is air of the hermetically sealed cabin, which when operating on the ground and at low altitudes is drawn through the

radiators by injectors 5 and 6. The injecting air enters into the injectors from lines 1 and 2 through the pneumatic valves 24 and 25. When there is no control signal to the pneumatic valves (if the signal is equal to zero), they are completely opened, and the vacuum system operates.

During takeoff there is an increase in the pressure drop between the hermetically sealed cabin and the intake atmosphere, the control signal enters into the pneumatic valves from the protective automaton 29 along the pneumatic line 28 for their closing and opening of the vacuum system. Further the air of the feed supply system enters into the excess pressure regulators 7 and 8. With an increase in movement, at the input of the regulators their reducing cross section is decreased, and with a pressure decrease this cross section is increased. If at the output of the regulators the pressure becomes higher than that permissible, then through safety valve 9 or 10 part of the air is expelled from the system. Then the air enters into the driers 11 and 12, where the moisture from it is absorbed by the silica gel filling the holders of the driers. The dried air, in passing through the air filters 13 and 14, in which the mechanical impurities are checked by a screen, enters into units 16 of the check valves along pipelines 15. From these units the prepared air along pipelines 17 enters into cavities of the appropriate devices of pneumatic controls. Units 16 ensure the air feed to devices of

pneumatic controls from either of the two lines 1 or 2 of the feed system and prevents air leakage from the apparatus.

When there is a pressure differential before the units 16 up to a value less than the load behind them, the units are closed, and the air to them comes from the other line of the feed system (the overflowing of air from one line to the other is prevented).

On the ground and at low altitudes, with operation of the vacuum system by ejectors 20, there is created a vacuum in cavities of the corresponding devices of pneumatic controls, which are connected to these ejectors by means of pipelines 21. The ejectors 20 are fed through pneumatic valves 24 and 25 along pipelines 18 and 19 from lines 1 and 2 of the feed system. The vacuum unit 22 of the check valves, pneumatically connected with the output of the control unit of the pressure regulator by pipeline 23, provides normal operation of the vacuum system on earth and at low flight altitudes irrespective of which of the two feed lines is switched on and also prevents the overflowing of air into the opposite line of the vacuum system.

Claim of the invention

The claim of the invention is for the preparation of air, for

example, for systems of air conditioning on aircraft, which contains an air-cooled radiator, an excess pressure regulator, air drier, air filter, and intake and regulating equipment, which differs in that for the purpose of ensuring feed to devices of pneumoautomatics during ground operating conditions of the conditioning system, the apparatus is equipped with a vacuum line with ejectors installed in parallel to it, which are connected to a feed line by means of a pneumatic valve controllable by the pressure differential between the hermetically sealed cabin and intake atmosphere introduced into the apparatus by the safeguard automaton.

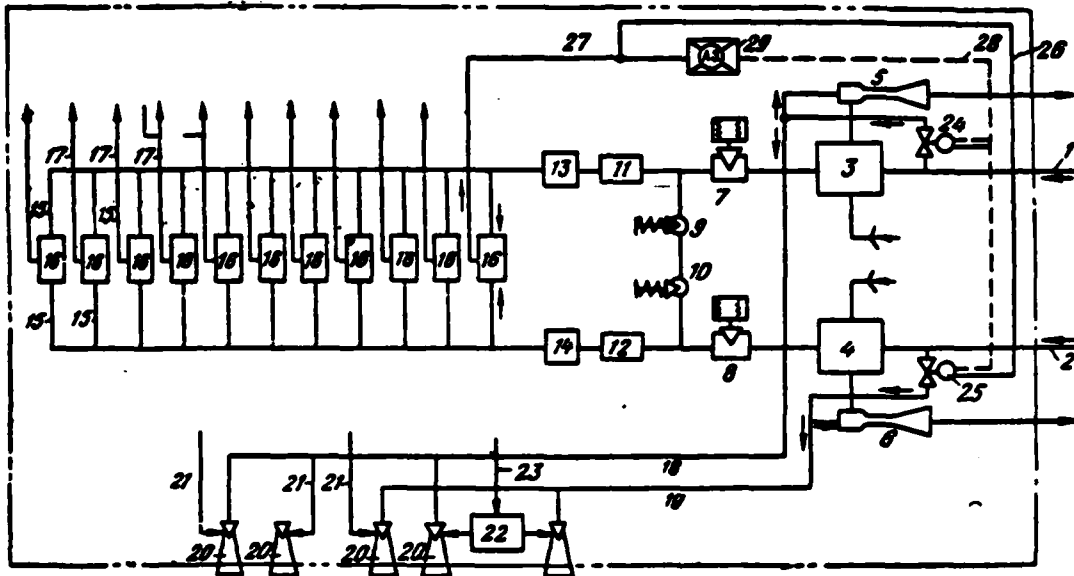

Schematic drawing.

END

FILMED

4-86

DTIC