

MICROCOPY RESOLUTION TEST CHART
NATIONAL BUREAU OF STANDARDS-1963-A

1

NBSIR 85-3145

CSFIT: A FORTRAN Program for Charge-Sheet Model Fitting of MOSFET Data

AD-A165 708

L.C. Witte

DTIC
ELECTE
MAR 21 1986
S D
D

U.S. DEPARTMENT OF COMMERCE
National Bureau of Standards
National Engineering Laboratory
Center for Electronics and Electrical Engineering
Semiconductor Electronics Division
Gaithersburg, MD 20899

November 1985

DTIC FILE COPY

DISTRIBUTION STATEMENT A
Approved for public release
Distribution Unlimited

Prepared for
Defense Nuclear Agency
Washington, DC 20305

NBSIR 85-3145

**CSFIT: A FORTRAN PROGRAM FOR
CHARGE-SHEET MODEL FITTING OF
MOSFET DATA**

L.C. Witte

U.S. DEPARTMENT OF COMMERCE
National Bureau of Standards
National Engineering Laboratory
Center for Electronics and Electrical Engineering
Semiconductor Electronics Division
Gaithersburg, MD 20899

November 1985

Prepared for
Defense Nuclear Agency
Washington, DC 20305



U.S. DEPARTMENT OF COMMERCE, Malcolm Baldrige, *Secretary*
NATIONAL BUREAU OF STANDARDS, Ernest Ambler, *Director*

Table of Contents

	Page
Abstract	1
1. Introduction	1
2. Theory	2
3. Computer Implementation	4
A. Software Modules	4
B. Limitations	7
4. Example Execution	7
5. Conclusions	8
6. Acknowledgments	17
7. References	17
Appendix A: Definition of Parameters	18
Appendix B: Example Execution Files	19

List of Figures

1. CSFIT computer program sections and subroutine flow diagram	5
2. CSFIT results compared to measured data for an unirradiated transistor $V_d = 0.25 \text{ V}$	9
3. CSFIT results compared to measured data for a 10 krad(Si) dose, $V_d = 0.25 \text{ V}$	10
4. CSFIT results compared to measured data for a 50 krad(Si) dose, $V_d = 0.25 \text{ V}$	11
5. CSFIT results compared to measured data for a 100 krad(Si) dose, $V_d = 0.25 \text{ V}$	12
6. CSFIT results compared to measured data for a 500 krad(Si) dose, $V_d = 0.25 \text{ V}$	13

<input checked="" type="checkbox"/>
<input type="checkbox"/>
<input type="checkbox"/>
Codes

This report does not have a DNA Report Number.
Per Mr. Charles L. Wilson, National Bureau of Standards



Dist	and/or Special
A-1	

7. The linear region characteristics from the charge-sheet model and the fitted values of mobility and flatband voltage, as a function of dose, compared to measured data, $V_d = 0.25$ V 14

8. Charge-sheet model characteristics in the saturated region using the fitted parameter compared to measured data for an unirradiated transistor 15

9. Charge-sheet model characteristics in the saturated region using the fitted parameter compared to measured data for a 100 krad(Si) dose 16

**CSFIT: A FORTRAN Program
for Charge-Sheet Model Fitting of MOSFET Data**

L. C. Witte
Semiconductor Electronics Division
National Bureau of Standards
Gaithersburg, MD 20899

ABSTRACT

A FORTRAN program, CSFIT, has been developed for fitting an expression for the current-voltage (I-V) characteristics of a long-channel MOSFET to experimental I-V curves. The one-dimensional charge-sheet model developed by Brews provides the basis for the I-V characteristics. The I-V characteristics given by this model are optimized with respect to a set of experimental data using the flatband voltage and the mobility as the only adjustable parameters. The program is written so that multiple sets of I-V data can be fit simultaneously if desired. The user must supply, in specified formats, a current-voltage data file, a device parameter file, and a starting value file.

KEY WORDS: charge-sheet model; flatband voltage; I-V characteristics; mobility; MOSFET; parameter extraction

1. INTRODUCTION

A FORTRAN program, CSFIT, has been developed for fitting an expression for the current-voltage (I-V) characteristics of a long-channel metal-oxide-semiconductor field-effect transistor (MOSFET) to experimental I-V curves. The sign convention adopted is appropriate for n-channel enhancement-mode devices. The one-dimensional charge-sheet model developed by Brews [1] provides the basis for the I-V characteristics. The I-V characteristics given by this model are optimized with respect to a set of experimental data using the flatband voltage and the mobility as the only adjustable parameters.

The program CSFIT executes the optimization according to the least squares criterion using a subroutine STEPIT, developed by J.P. Chandler [2]. STEPIT finds a local minimum of any given smooth function of several parameters. CSFIT reads in dc MOSFET I-V data and physical device parameters and then calls the subroutine STSET for the initialization of the STEPIT input parameters. STEPIT performs the minimization of the specified current model. The subroutine MODEL, called by STEPIT, uses the current equation derived by Brews [1]. The MODEL routine then calls the subroutine CS0. The CS0 and FUNCTION subroutines, developed by C. L. Wilson [3], solve for the potential along the oxide-silicon surface at the drain and source end of the channel needed to determine the drain current. The subroutine FUNCTION is called by CS0 to determine the actual drain current once the potential at the drain and source has been determined.

In section 2, a brief discussion of the formulation of the charge-sheet model is presented. In particular, the current equation is given along with a discussion of the method of solving for the boundary conditions of the potential along the oxide-silicon surface for a given gate voltage and drain voltage. The current equation and the boundary conditions are precisely what the CS0 computer code solves.

In section 3, the specific procedures needed to implement CSFIT are discussed. The function of each of the principal subroutines is outlined. Limitations of the program are discussed.

In section 4, verification of CSFIT is presented. An example of usage is demonstrated by optimizing the flatband voltage and mobility when radiation-induced interface effects are present. The optimized values are then used to generate current-voltage curves in the subthreshold, linear, and saturated regions of MOSFET operation. The input files used to obtain the optimized parameters and the output file results are given in Appendix B. A print-out of the CSFIT computer program is given in Appendix C.

2. THEORY

The charge-sheet model of the MOSFET assumes that the carrier density in the inversion layer is contained in a charge sheet of zero thickness. Thus, the current is constrained to flow along the oxide-silicon interface and there is no voltage drop across the inversion layer. For long-channel devices, it can be assumed that Poisson's equation must be solved in one dimension only because the potential variations along the channel are gradual compared to those normal to the channel. The discontinuity condition across the oxide-silicon interface is then applied, implying that the carrier density per unit area $N(y)$ is contained in a charge sheet of zero thickness. The coordinate system used measures "y" along the channel of a MOSFET from the source toward the drain, "z" along the width of the drawn gate, and "x" perpendicular to the plane of the gate.

Using an arbitrary potential along the oxide-silicon surface $\phi(x=0, y)$, Poisson's equation for the potential in the oxide and the semiconductor can be solved. Then, with a derived equation for $N(y)$ (refer to Brews for details [1]), an integral equation for the surface potential is obtained. This equation is then solved, with the resulting drain current given by

$$\begin{aligned}
 I = \frac{1}{\beta} \mu^* \left(\frac{Z}{L} \right) & \left\{ C_{ox} (1 + \beta V_G) (\phi_{SL} - \phi_{S0}) - \frac{\beta}{2} C_{ox} (\phi_{SL}^2 - \phi_{S0}^2) \right. \\
 & - q N_A L_B \left(\frac{2\sqrt{2}}{3} \right) \left[(\beta \phi_{SL} - 1)^{3/2} - (\beta \phi_{S0} - 1)^{3/2} \right] \\
 & \left. + q N_A L_B \sqrt{(2)} \left[(\beta \phi_{SL} - 1)^{1/2} - (\beta \phi_{S0} - 1)^{1/2} \right] \right\}, \quad (11)
 \end{aligned}$$

where $\phi_{SL} = \phi_S(L)$ and $\phi_{S0} = \phi_S(0)$. This is eq (11) in the paper by Brews [1]. Definitions of the parameters used in eq (11) are given in Appendix A. The value of ϕ_{S0} and ϕ_{SL} for a given gate voltage V_G and drain voltage V_D must be known before the current eq (11) can be solved.

At the source end of the channel, ϕ_{S0} is taken from the one-dimensional Poisson equation for zero drain voltage with $(\beta\phi_{S0} - 1) \gg \exp(-\beta\phi_{S0})$, yielding

$$C_{ox}(V_G - \phi_{S0}) = qN_A L_B \sqrt{2} \left[\beta\phi_{S0} - 1 + \left(\frac{n_i}{N_A} \right)^2 e^{\beta\phi_{S0}} \right]^{1/2}, \quad (12)$$

which is eq (12) in Brews' paper. Equation (12) can be rearranged to provide an algorithm for ϕ_{S0} . The iterative form becomes

$$\phi_{S0}^{i+1} = \phi_{S0} + \frac{1}{\beta} \ln \left\{ \frac{[\beta(V_G - \phi_{S0}^i)]^2}{[1 + (\beta\phi_{S0}^i - 1) / \exp \beta(\phi_{S0}^i - 2\phi_B)]} \right\}, \quad (13)$$

where ϕ_{S0}^i is the i th trial value for ϕ_{S0} and the initial trial value is

$$\phi_{S0} = 2\phi_B - \frac{2}{\beta} \ln \left[\beta \frac{\sqrt{2} q N_A L_B}{C_{ox}} \right].$$

Once the iterative algorithm for the potential at the source has converged, the resulting potential can be used in the current equation.

To determine the potential at the drain end of the channel, for a given V_D and V_G , eqs (14), (16), and (17) from the paper by Brews [1] were used. These equations are as follows:

$$qN(o) = qN_A L_B \sqrt{2} \left\{ \left[\beta\phi_{S0} - 1 + \left(\frac{n_i}{N_A} \right)^2 e^{\beta\phi_{S0}} \right]^{1/2} - (\beta\phi_{S0} - 1)^{1/2} \right\} \quad (14)$$

$$\beta\phi_{SL} = \beta\phi_{S0} + \beta V_D + \ln \left[\frac{N(L)}{N(o)} \right] \quad (16)$$

$$qN(L) = C_{ox}(V_G - \phi_{SL}) - qN_A L_B \sqrt{2} (\beta\phi_{SL} - 1)^{1/2}. \quad (17)$$

Using eqs (14) and (17) in (16) results in a value for the potential at the drain end of the channel. With the source and drain potentials, ϕ_{S0} and ϕ_{SL} , the current eq (11) can be solved. Equation (11) is the function used to be minimized in the optimization routine.

3. COMPUTER IMPLEMENTATION

A. SOFTWARE MODULES

In order to run the program, the user should carry out the following steps. The user needs to obtain a copyrighted copy of STEPIT from the distributing organization* and create three input files in the required format. After creating the three input files, the user will need to link CSFIT to STEPIT. Once the routines are linked, the user may then proceed to execute the optimization routine. The program will then prompt the user for the I-V data file name, the device parameter file name, the initial starting value file name, and finally, the desired output result file name. This sample set of linkage control statements has been used to execute the CSFIT program on the DEC VAX 11/780 under the VMS system.

The computer program, CSFIT, consists of three sections: a data input and initialization section, a fitting program, STEPIT, developed by J.P. Chandler [2], and a model section, as shown in figure 1. In the following paragraphs of this section, a circled number refers to an encircled step on the flow-diagram given in figure 1.

The input section of CSFIT consists of the input routine ① and STSET ②. The input routine reads in measured dc transistor data and known device parameters. This routine normalizes device parameters. The STSET subroutine, developed by Chandler [2], reads in constraints on the minimization process and sets controlling parameters for the fitting routine STEPIT.

The fitting section uses STEPIT ③ to minimize the objective function subject to the constraints imposed by the user. The method used in STEPIT is an accelerated version of the 'cyclic variation' or 'one-variable-at-a-time' method. First, each fitting parameter $x(j)$ is varied individually. If progress is made by finding a lower value of the objective function, the step size is doubled. However, the number of steps in this phase is limited. When a local minimum has been found, quadratic interpolation is used in an attempt to refine the position of the minimum. The minimum point is never shifted unless a better (lower) value of the objective function is found.

Once each of the $x(j)$ has been varied, attempts are made to move along the resultant of all of these individual displacements. Doubling of the step size follows each successful step, this time with no limit on the number of steps. Quadratic interpolation again follows. STEPIT consists of several subprograms which are referenced in [2].

The model section consists of the subroutines MODEL ④, CS0 ⑤, and FUNCTION ⑥. The CS0 subroutine solves the charge-sheet equations for the potentials at the drain and source end of the channel, passing the values to FUNCTION which calculates the drain-to-

* STEPIT is available from the Quantum Chemistry Program Exchange, Indiana University, Bloomington, IN 47401.

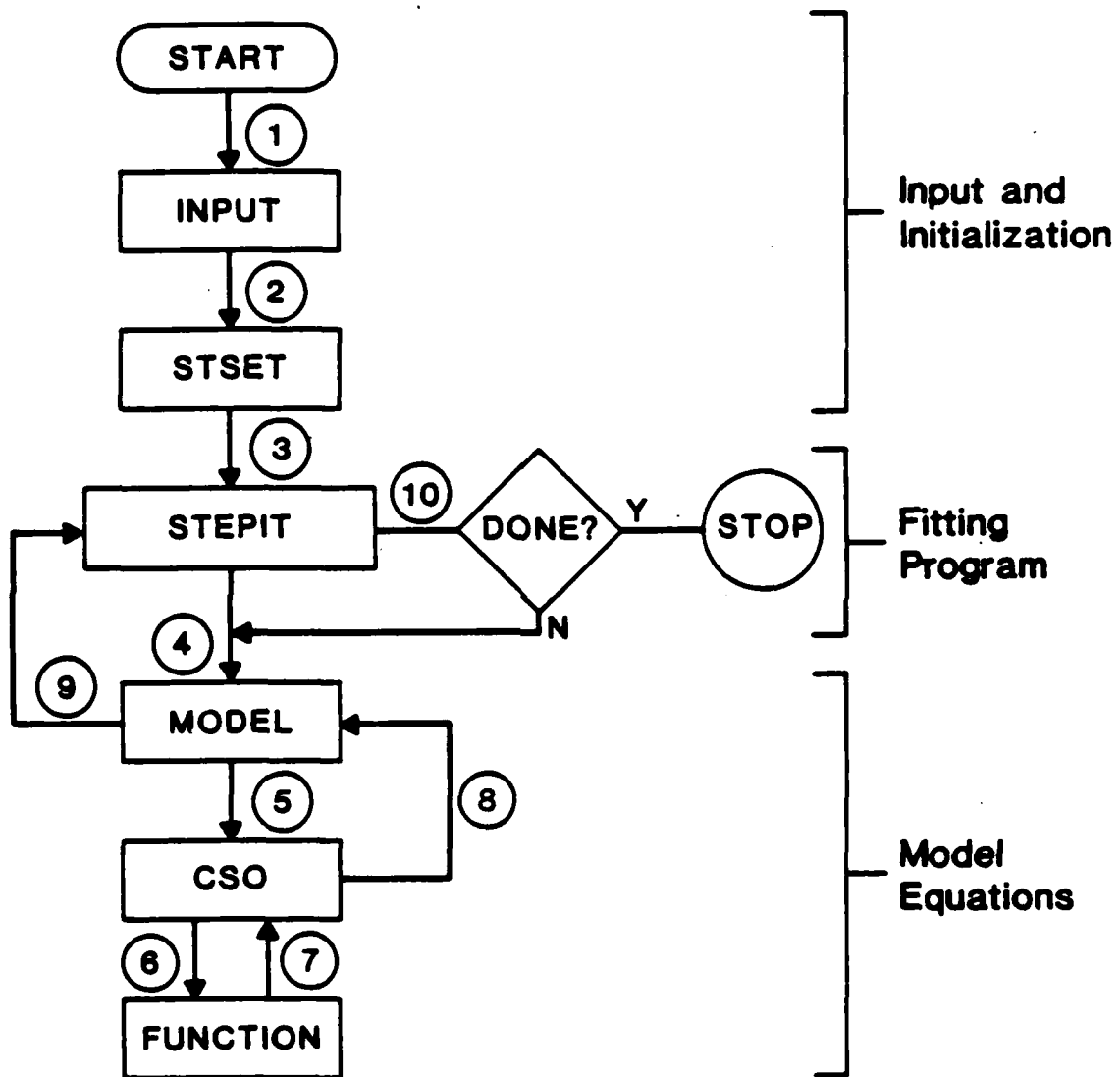

Figure 1. CSFIT computer program sections and subroutine flow diagram.

source current. The calculated current is passed via ⑦ and ⑧ to the MODEL subroutine, which generates an objective function which is the sum of the squares of the differences between the measured and charge-sheet model drain currents. The STEPIT subroutine receives the objective function via ⑨ and proceeds to ⑩ to determine if the convergence tolerance on minimization is satisfied. When the convergence tolerance is satisfied, CSFIT is finished. If the convergence tolerance is not satisfied, steps ④ to ⑩ are repeated.

The first file is the current-voltage (IV) data file. The data are read into an (npts) x 3 array, where npts is the total number of points in all of the data sets. CSFIT, without any modifications, assumes that the measured source-to-drain voltage for each data set is in npts x 1, the measured drain current is in npts x 2, and the measured gate voltage is in npts x 3. This specific format can easily be changed to meet the user's needs if so desired. Thus, the required I-V data file would be as follows:

npts = the total number of data points

```
vds(i)   vg(i)   id(i)
vds(j)   vg(j)   id(j)
vds(k)   vg(k)   id(k)
```

The second file is the device parameter file. The following format is required:

```
nvds      = the number of data sets
vds(1)    = source-to-drain voltages for each data set
vds(i)    i=1,nvds
npset(1)  = number of data points in each set
npset(i)  i=1,nvds
nch       = average channel doping (cm3)
tox       = oxide thickness (cm)
ljun      = lateral source and drain diffusion under the gate (cm)
lch       = drawn length of polysilicon (cm)
z         = width of channel (cm)
```

The third file is the initial starting value file, with the following required format:

```
initial fbv(1)
initial mob(1)
initial fbv(2)
initial mob(2)
initial fbv(nvds)
initial mob(nvds)
```

The initial values of flatband voltage (fbv(i)) must be equal to or less than zero. The subroutine STSET is an initialization subroutine for the actual optimization routine STEPIT. STSET allows the user to set the following controlling parameters:

```
x(i)      = initial values of the fitting parameter, on which the function to be
            minimized depends.
```

xmax(i) = the upper limit on the value of $x(i)$.
xmin(i) = the lower limit on the value of $x(i)$.
deltx(i) = the initial step by which $x(i)$ is varied.
delmn(i) = the lower limit (convergence tolerance) on the step size for $x(i)$.
mask(i) = set nonzero if $x(i)$ is not to be varied, but rather is to be held at its initial value.
ntrac = determines the amount of printout from STEPIT.
 ntrac=1 to obtain trace during the minimization process
 ntrac=0 for initial and file output only
 ntrac=-1 for no output except error messages

STSET will set all the above to default value except ntrac; i.e., ntrac must be set by the user. Without modification, CSFIT is written with the above parameters set to the following values:

x(i) = initial starting value file
xmax(i) = default value of $+1.0E+35$
xmin(i) = default value of $-1.0E-35$
deltx(i) = default value of $x(i)/10$
delmn(i) = $1.0E-04$
mask(i) = default value of 0
ntrac = 1

The user need not be concerned with modification of the controlling parameters unless a fitting parameter is desired to be held constant ($mask(i)=1$), or a fitting parameter is desired to be held within a smaller range of values.

B. LIMITATIONS

Often, the error subroutines in STEPIT cannot be computed. The error routines sometimes start with poor initial starting values for the CS0 algorithm, resulting in the square root of a negative number. If this occurs, the computed results should be considered valid.

If the CSFIT routine is given poor initial starting values for the fitting parameters, the CS0 algorithm will result in a square root of a negative number, and hence, the user must correct initial starting values.

4. EXAMPLE EXECUTION

In this section, CSFIT is demonstrated using results obtained with an irradiated n-channel enhancement-mode MOSFET. Prior to irradiation and after irradiation exposure to 10, 50, 100, and 500 krad(Si), the current-voltage characteristics of the transistor were measured. All devices were biased with +9 V on the gate and source, drain, and substrate grounded. The parameters used in the simulation are given in Table 1. Techniques for determining these parameters have been discussed in the literature [4].

Table 1
Device Parameters

L_{ch}	6.42 μm
V_G, V_D	0.5 to 5.0 V, 0.25 V
t_{ox}	0.056 μm
n_{ch}	$1 \times 10^{16} / \text{cm}^3$
L_{jun}	0.70 μm
Z	16.96 μm

Fitted values for the flatband voltage and mobility were obtained simultaneously for the 0, 10, 50, 100, and 500 krad(Si) doses, and then were used in the charge-sheet model to generate model I-V curves.

Comparison of the charge-sheet model fitted values with measured data shows good agreement in the subthreshold region, the linear region, and the saturation region. Figure 2 compares the fit to measured data for an unirradiated sample. In figure 3, the fit after a 10 krad(Si) dose is compared to measured data. In figure 4, the fit after a 50 krad(Si) dose is compared to measured data. As the dose is increased above 50 krad(Si), the effects of the interface trapped charge energy distribution become important. As shown in figures 5 and 6, for devices irradiated at 100 krad(Si) and 500 krad(Si), respectively, the accuracy of the model degrades with increased irradiation dose.

The linear region I-V characteristics generated from the charge-sheet model and the fitted values of mobility and flatband voltage are compared to measured data as a function of dose in figure 7. Linear region results obtained are in good agreement with measured results.

Charge-sheet model I-V curves in the saturation region using the fitted parameters are compared to measured data in figure 8 for an unirradiated sample. Figure 9 gives a similar plot after a 100 krad(Si) dose.

5. CONCLUSIONS

A fitting program has been developed to provide an optimum set of parameter values for flatband voltage and mobility for a long-channel MOSFET based on the charge-sheet model formulated by Brews [1]. This fitting procedure has been demonstrated using data from an n-channel enhancement-mode MOSFET exposed to ionizing radiation.

6. ACKNOWLEDGMENTS

The author would like to thank C. L. Wilson and K. F. Galloway for their assistance and guidance in preparing this work. Also, I would like to thank M. Gaitan, P. Roitman, and

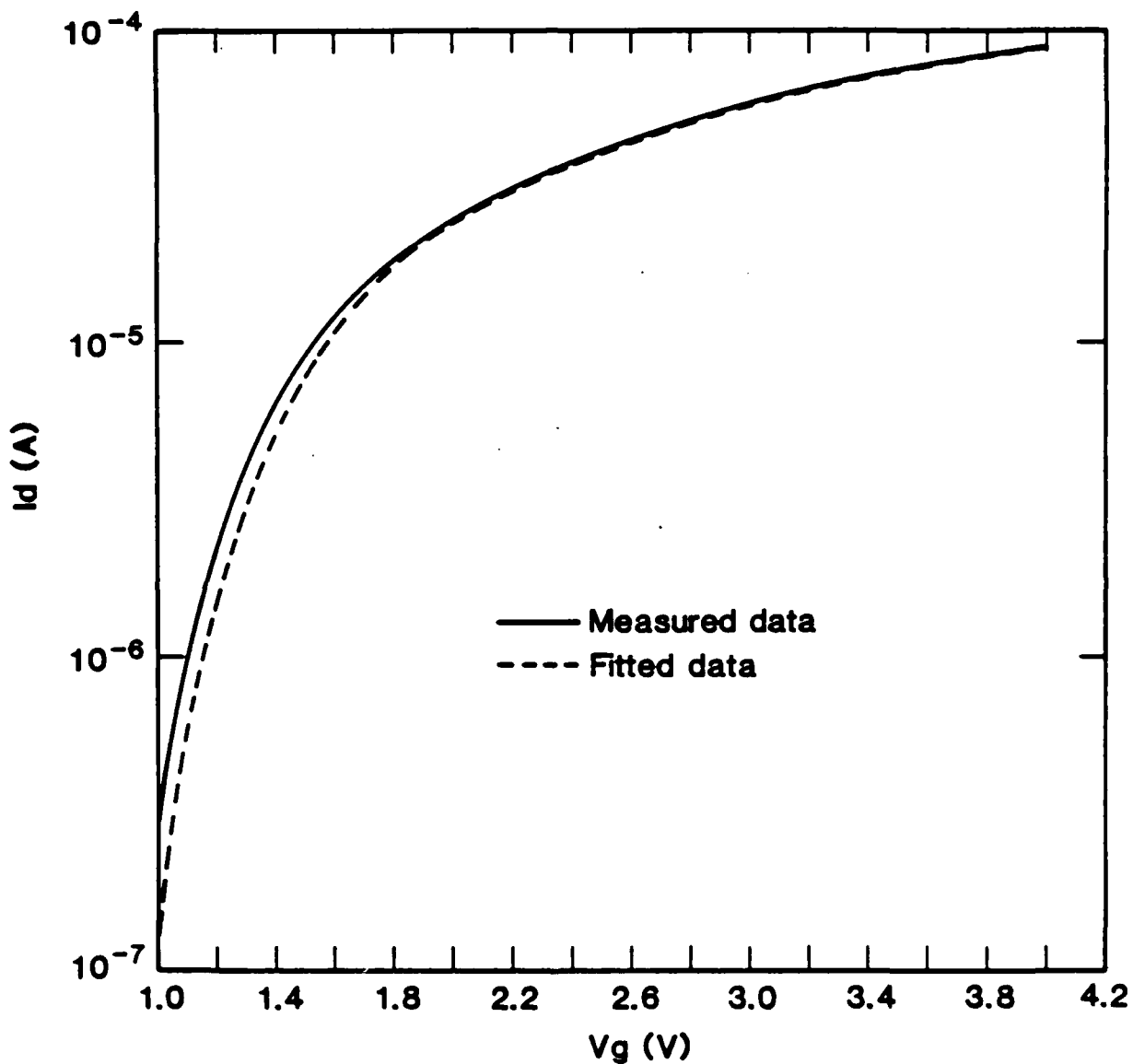

Figure 2. CSFIT results compared to measured data for an unirradiated transistor, $V_d=0.25$ V.

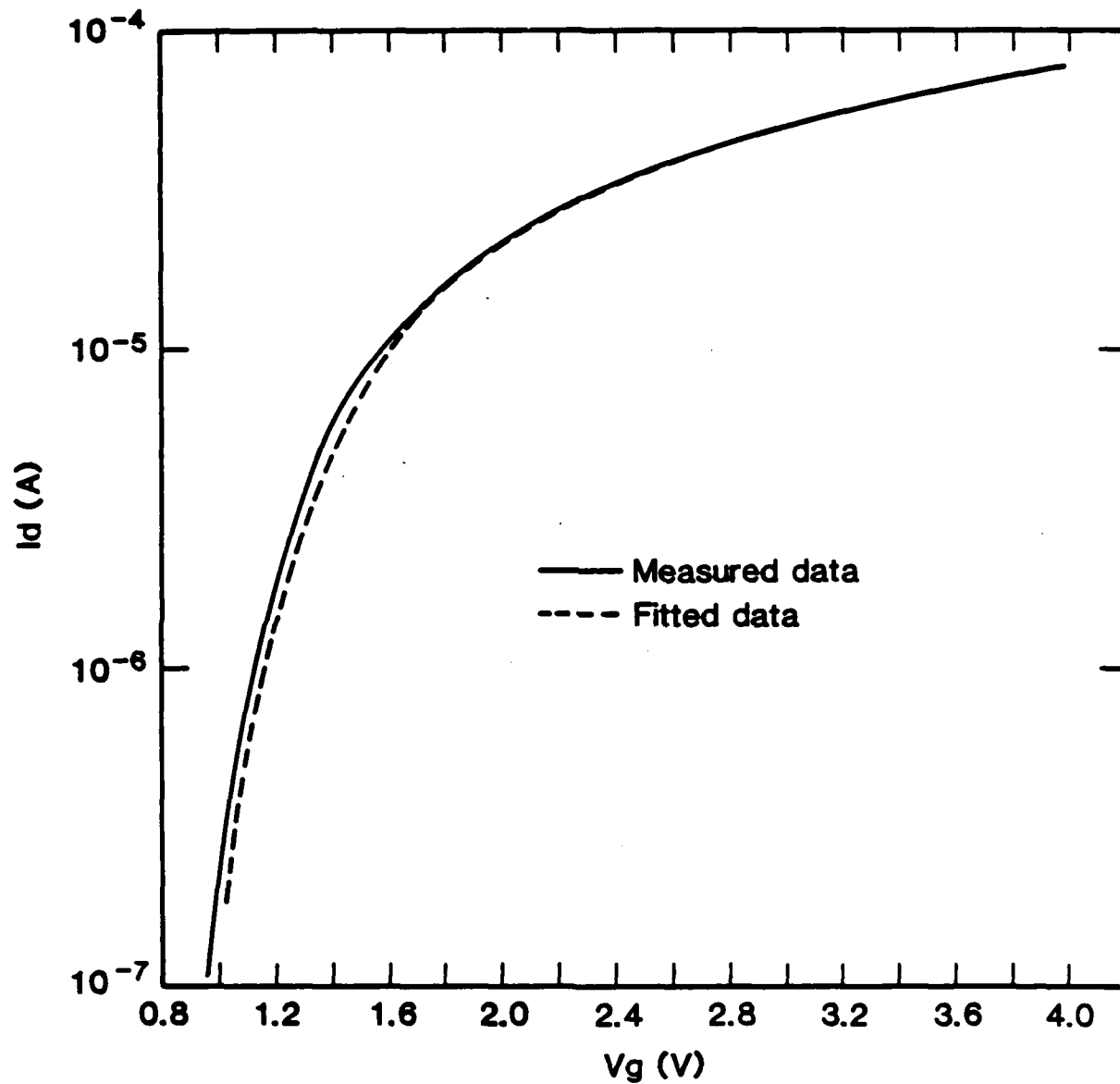

Figure 3. CSFIT results compared to measured data for a 10 krad(Si) dose, $V_d=0.25$ V.

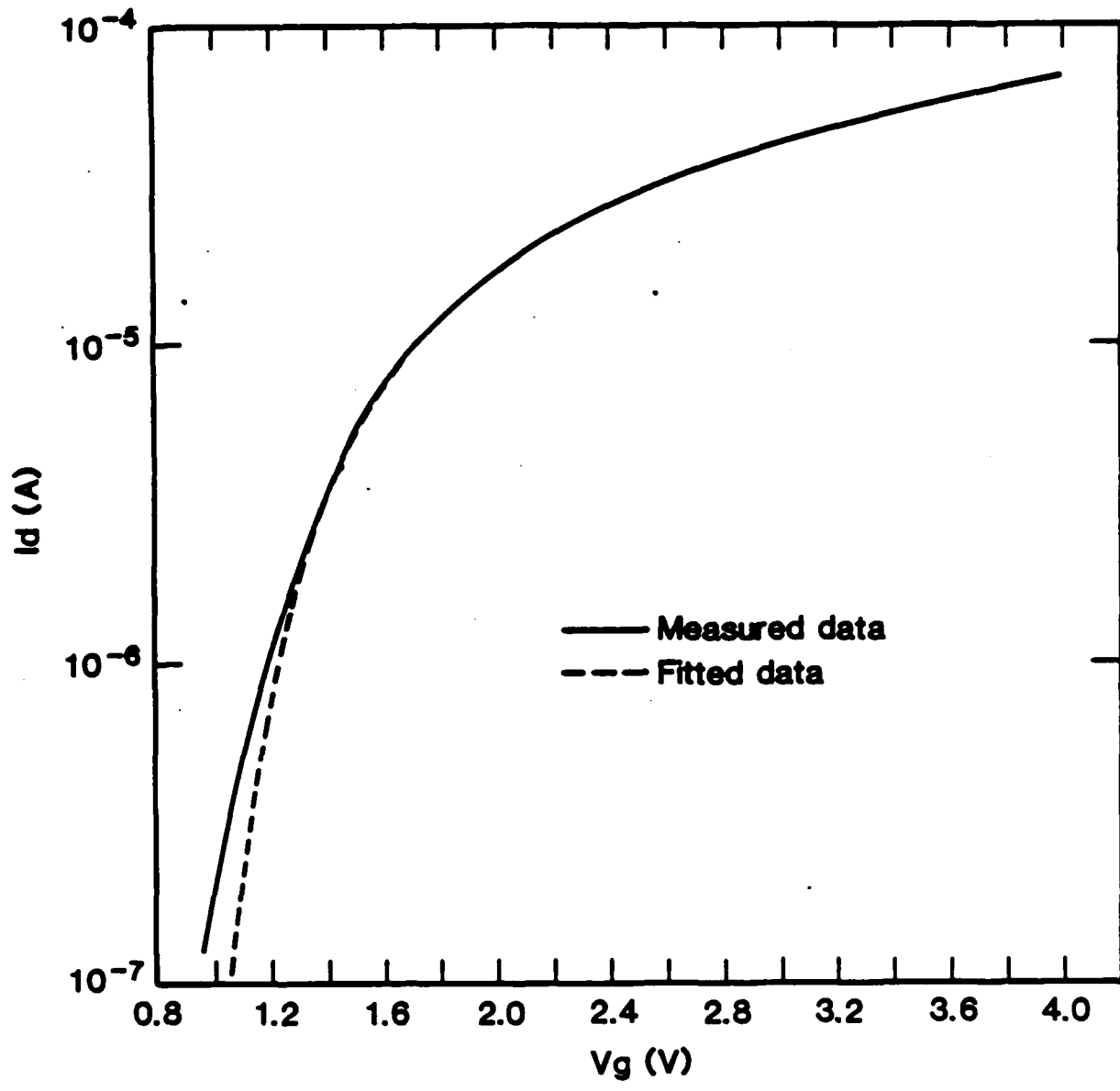

Figure 4. CSFIT results compared to measured data for a 50 krad(Si) dose, $V_d=0.25$ V.

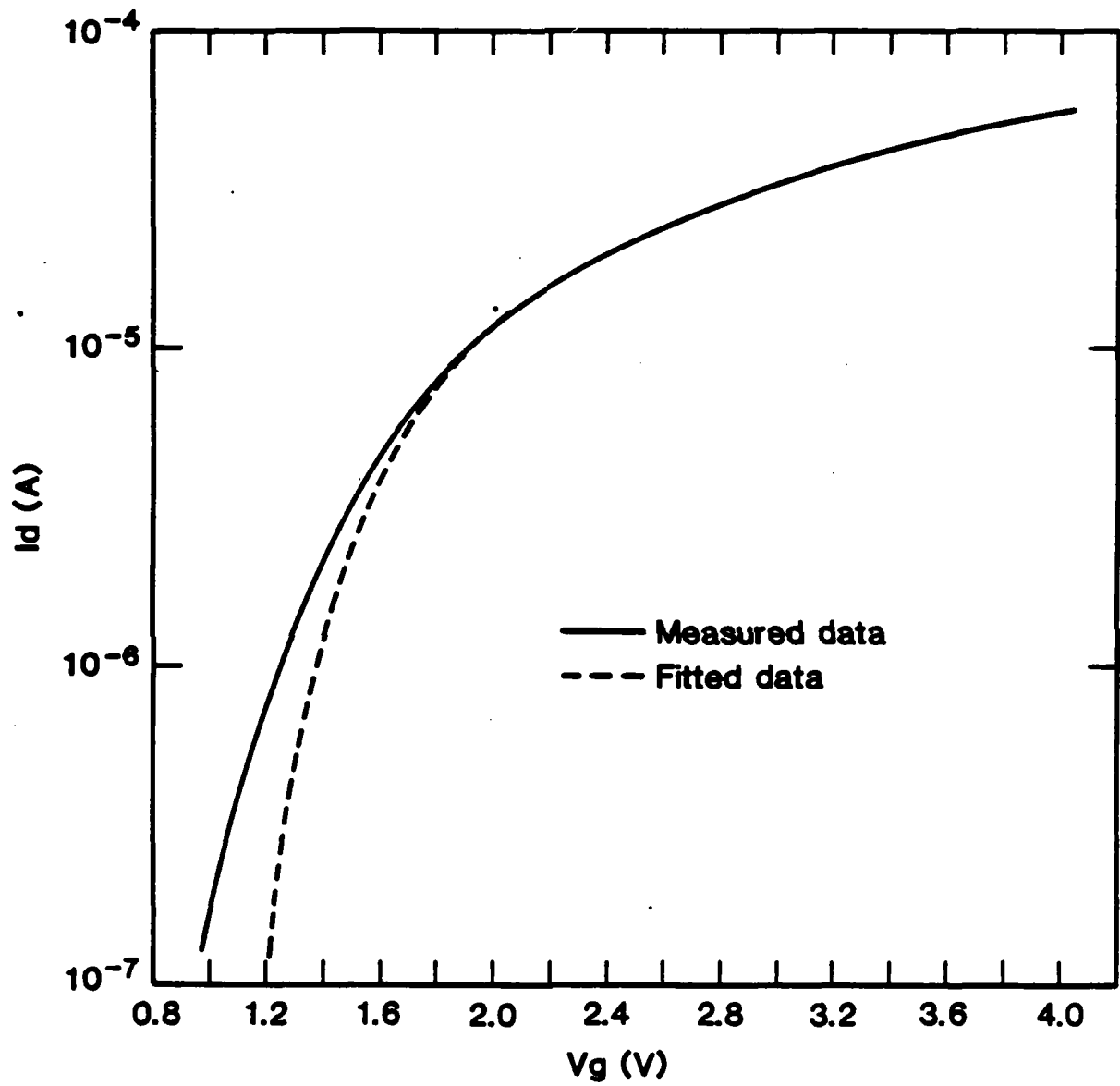

Figure 5. CSFIT results compared to measured data for a 100 krad(Si) dose, $V_d=0.25$ V.

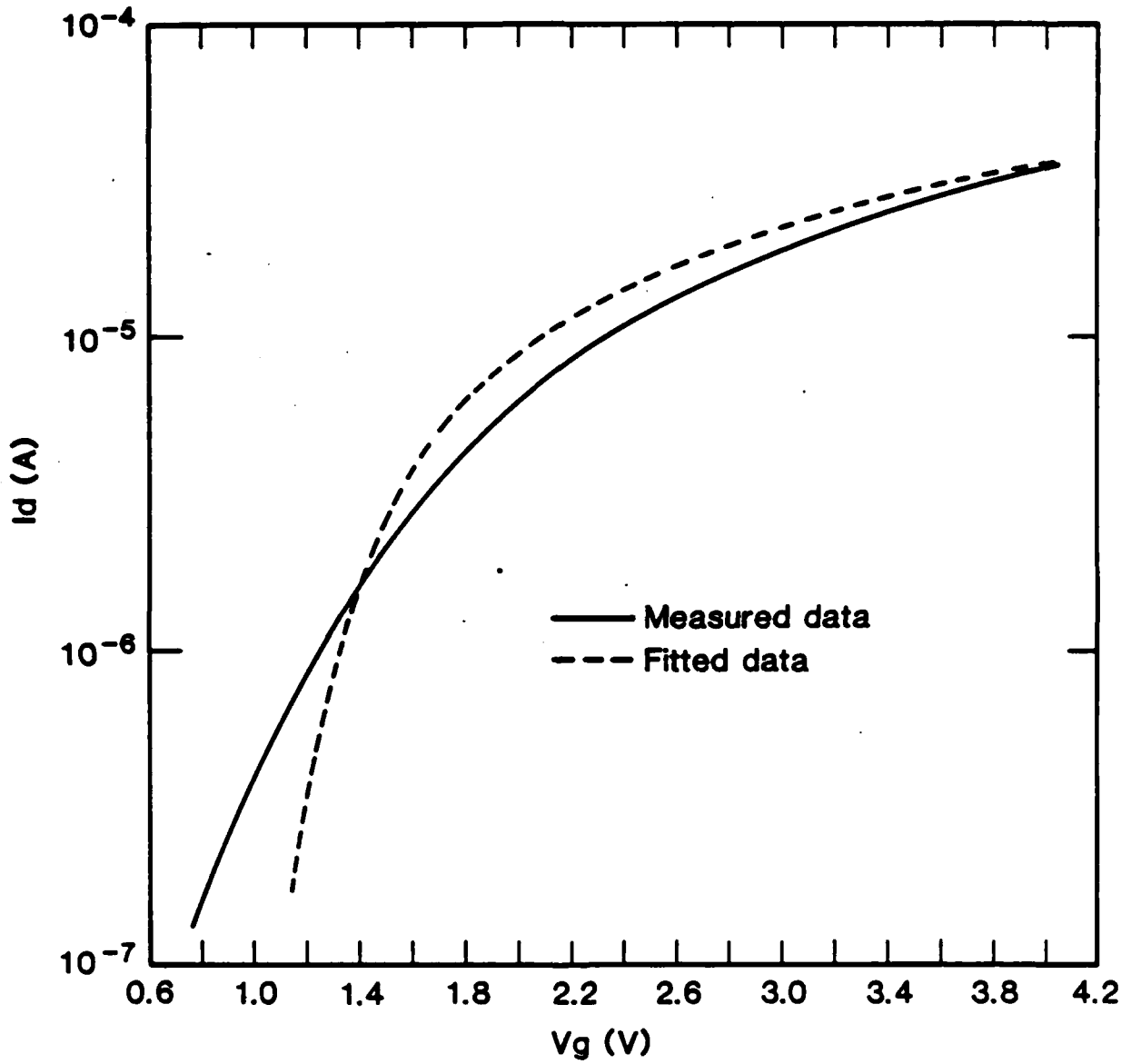

Figure 6. CSFIT results compared to measured data for a 500 krad(Si) dose, $V_d=0.25$ V.

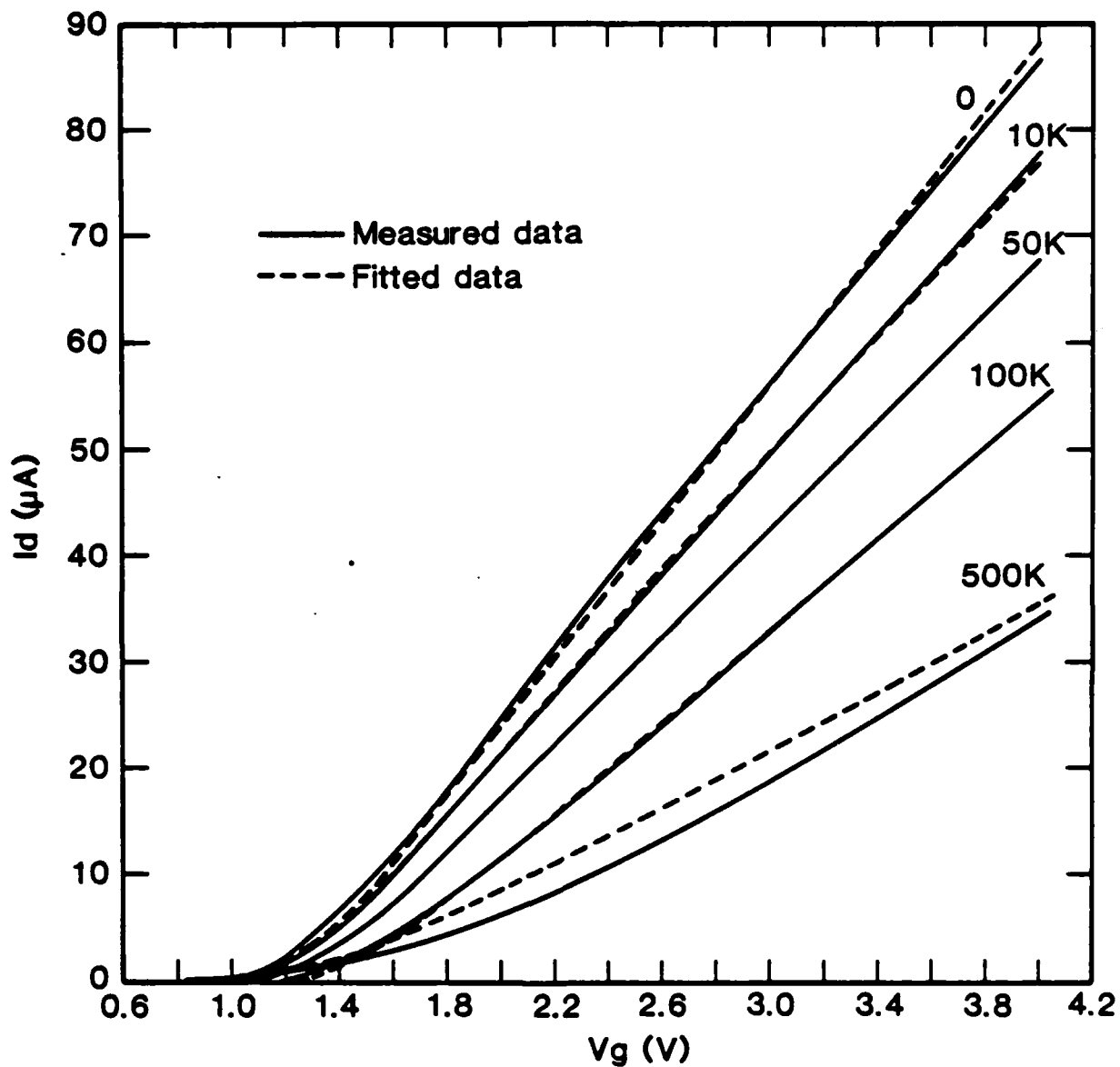

Figure 7. The linear region characteristics from the charge-sheet model and the fitted values of mobility and flatband voltage, as a function of dose, compared to measured data, $V_d=0.25$ V.

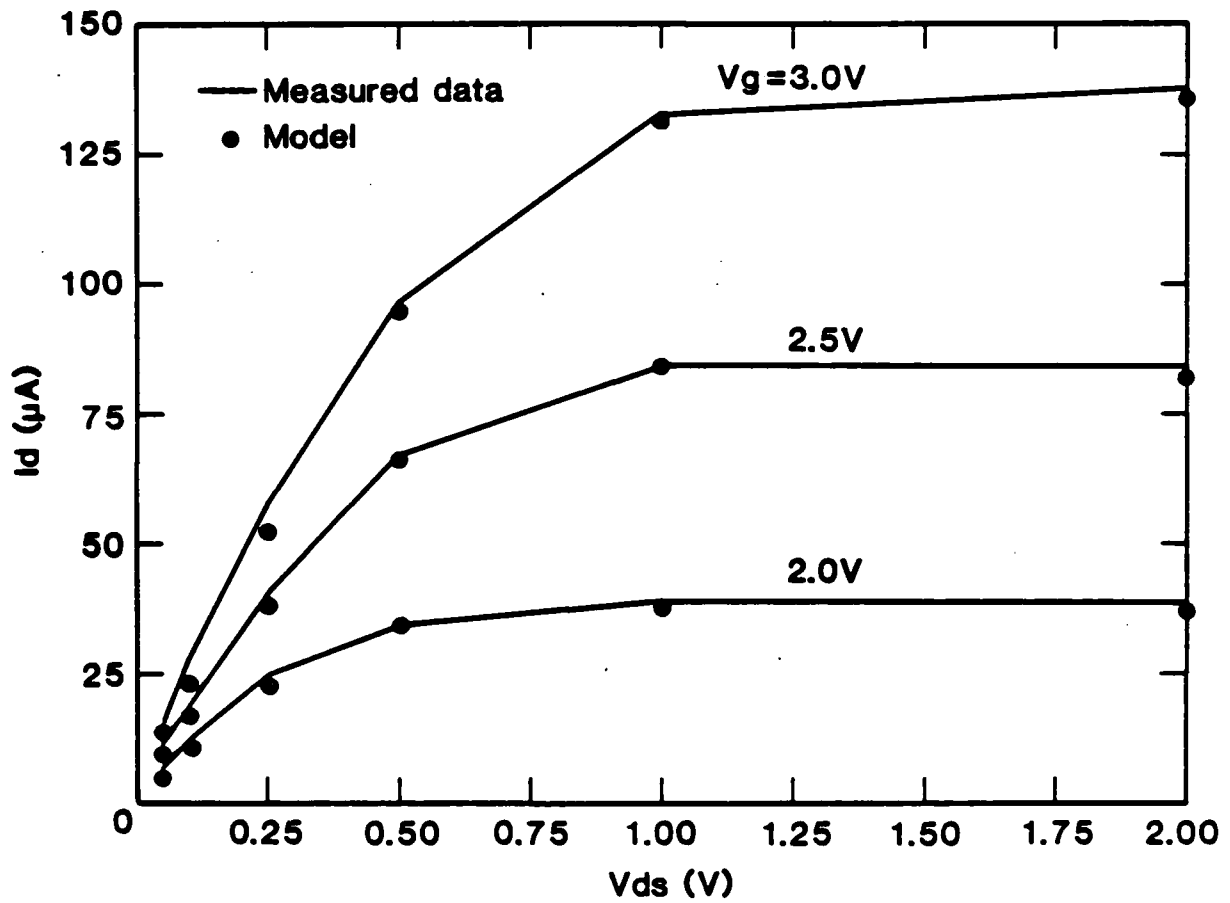

Figure 8. Charge-sheet model characteristics in the saturated region using the fitted parameter compared to measured data for an unirradiated transistor.

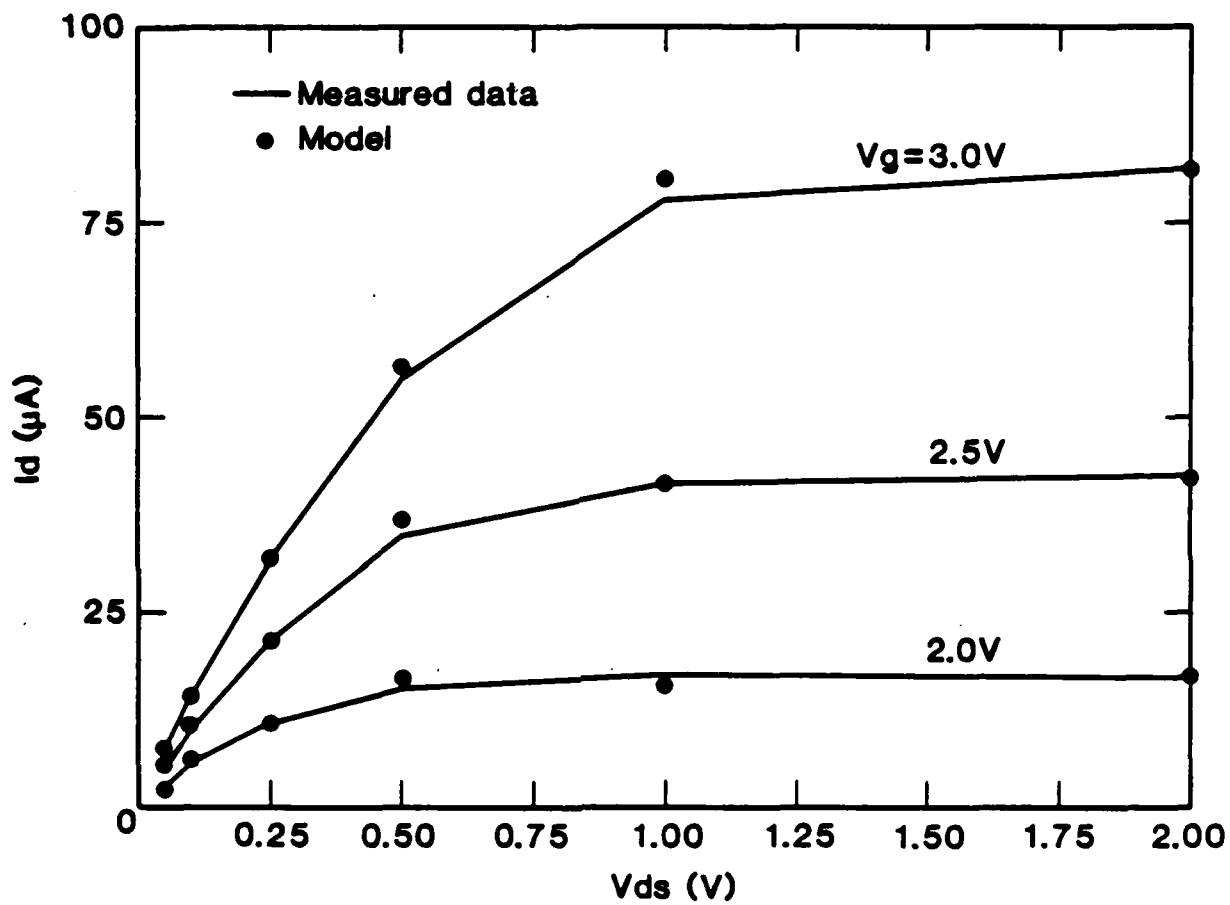

Figure 9. Charge-sheet model characteristics in the saturated region using the fitted parameter compared to measured data for a 100 krad(Si) dose.

T. J. Russell for the experimental I-V data and the physical data used in this report. Special thanks go to E. J. Walters for preparing the manuscript.

7. REFERENCES

1. Brews, J. R., A Charge-Sheet Model of the MOSFET, *Solid-State Electronics* 21, 345-355 (1978).
2. Chandler, J. P., STEPIT: Minimizing or Maximizing a Function, Department of Computing and Information Sciences, Oklahoma State University, Stillwater, OK 74074.
3. CS0 is used to provide an initial guess in the CS1 program. CS0 is reproduced here as part of CSFIT. See: C. L. Wilson and J. L. Blue, CS1: A Two-Dimensional Finite Element Charge-Sheet Model of a Short-Channel MOS Transistor, NBSIR 82-2471 (April 1982).
4. Wilson, C. L., Roitman, P., and Blue, J. L., High Accuracy Physical Modeling of Submicron MOSFETs, *IEEE Trans. Electron Devices* ED-32, 1246-1258 (July 1985).

Appendix A: Definition of Parameters

$\phi_{SL} = \phi_S(L)$ = the potential at the drain end of the channel

$\phi_{S0} = \phi_S(0)$ = the potential at the source end of the channel

n_{ch} = average channel doping

$$\beta = \frac{q}{kT}$$

n_i = intrinsic carrier concentration

$\phi_B = \beta \ln \left(\frac{N_A}{n_i} \right)$ = bulk Fermi potential

L_B = (Debye Length) = $\left(\frac{kT \kappa_{ox} \epsilon_0}{q^2 N_A} \right)^{1/2}$

C_{ox} = oxide capacitance per unit area

t_{ox} = oxide thickness

L_{ch} = channel length = $L_{poly} - 2L_{jun}$

L_{poly} = gate poly length

L_{jun} = lateral junction depth

Z = channel width

μ^* = effective mobility (fitting parameter)

V_{FB} = flatband voltage (fitting parameter)

V_G = gate voltage

V_D = drain voltage

APPENDIX B: Example Execution Files

The following three required files, (1) I-V data file, (2) parameter file, and (3) initial starting value file, were used to obtain the verification results, with the (4) resulting output file included. The I-V data file used consisted of 403 points. There was a total of five data sets, one set for each radiation dose. The files were as follows:

(1) I-V data file

403

			V_d	V_g	I_D
0.27147	8.597500E-01	1.299160E-08			
.	.	.			
0.25198	7.079650E-01	1.428790E-09			
.	.	.			
0.25165	6.080440E-01	1.564180E-09			
.	.	.			
0.25048	4.591630E-01	1.422954E-09			
.	.	.			
0.25079	9.345300E-01	3.364700E-09			
.	.	.			
.	.	.			

(2) parameter file

5 i
0.10 $V_d(i)$
0.25
0.5
1.0
2.0
64 mpts(i)
67
69
82
121
1.0E+16 556E-08 0.7E-04 6.416E-04 16.956E-04 n_{ch} t_{ox} L_{jun} L_{poly} Z

(3) initial starting value file

0.1 500 $V_{fb}(i)$ $\mu(i)$
0.1 500
0.1 500
0.1 500

(4) The resulting output file

Vfb = -7.59070E-01 Mu = 448.10 Vd = 0.05 Set 1

Vg	Id	Idcal
0.7000E+00	0.2205E-08	0.8265E-09
0.7500E+00	0.5492E-08	0.3088E-08
0.8000E+00	0.1168E-07	0.1068E-07
0.8500E+00	0.3415E-07	0.3064E-07
0.9000E+00	0.7210E-07	0.8757E-07
0.9500E+00	0.1960E-06	0.2345E-06
0.1000E+01	0.4269E-06	0.5594E-06
0.1050E+01	0.8419E-06	0.1163E-05
0.1100E+01	0.1389E-05	0.1415E-05
0.1150E+01	0.2331E-05	0.2091E-05
0.1200E+01	0.3363E-05	0.2845E-05
0.1250E+01	0.4518E-05	0.3655E-05
0.1300E+01	0.5754E-05	0.4504E-05
0.1350E+01	0.7036E-05	0.5382E-05
0.1400E+01	0.8341E-05	0.6281E-05
0.1450E+01	0.9659E-05	0.7198E-05
0.1500E+01	0.1098E-04	0.8128E-05
0.1550E+01	0.1229E-04	0.9070E-05
0.1600E+01	0.1359E-04	0.1002E-04
0.1650E+01	0.1489E-04	0.1098E-04
0.1700E+01	0.1617E-04	0.1195E-04
0.1750E+01	0.1744E-04	0.1292E-04
0.1800E+01	0.1857E-04	0.1389E-04
0.1850E+01	0.1994E-04	0.1487E-04
0.1900E+01	0.2116E-04	0.1586E-04
0.1950E+01	0.2237E-04	0.1685E-04
0.2000E+01	0.2357E-04	0.1784E-04
0.2050E+01	0.2476E-04	0.1883E-04
0.2100E+01	0.2593E-04	0.1983E-04
0.2150E+01	0.2709E-04	0.2083E-04
0.2200E+01	0.2823E-04	0.2183E-04
0.2250E+01	0.2936E-04	0.2283E-04
0.2300E+01	0.3048E-04	0.2384E-04
0.2350E+01	0.3159E-04	0.2485E-04
0.2400E+01	0.3268E-04	0.2586E-04
0.2450E+01	0.3377E-04	0.2687E-04
0.2500E+01	0.3484E-04	0.2788E-04
0.2550E+01	0.3590E-04	0.2889E-04
0.2600E+01	0.3695E-04	0.2991E-04
0.2650E+01	0.3799E-04	0.3092E-04
0.2700E+01	0.3902E-04	0.3194E-04
0.2750E+01	0.4004E-04	0.3296E-04
0.2800E+01	0.4105E-04	0.3398E-04
0.2850E+01	0.4205E-04	0.3500E-04
0.2900E+01	0.4304E-04	0.3602E-04
0.2950E+01	0.4403E-04	0.3704E-04
0.3000E+01	0.4500E-04	0.3806E-04
0.3050E+01	0.4597E-04	0.3908E-04
0.3100E+01	0.4693E-04	0.4011E-04
0.3150E+01	0.4787E-04	0.4113E-04
0.3200E+01	0.4882E-04	0.4216E-04
0.3250E+01	0.4975E-04	0.4318E-04
0.3300E+01	0.5068E-04	0.4421E-04
0.3350E+01	0.5160E-04	0.4523E-04
0.3400E+01	0.5251E-04	0.4626E-04
0.3450E+01	0.5342E-04	0.4729E-04
0.3500E+01	0.5432E-04	0.4832E-04

0.3550E+01	0.5521E-04	0.4935E-04
0.3600E+01	0.5609E-04	0.5038E-04
0.3650E+01	0.5697E-04	0.5141E-04
0.3700E+01	0.5785E-04	0.5244E-04
0.3750E+01	0.5872E-04	0.5347E-04
0.3800E+01	0.5957E-04	0.5450E-04
0.3850E+01	0.6043E-04	0.5553E-04
0.3900E+01	0.6128E-04	0.5656E-04
0.3950E+01	0.6212E-04	0.5760E-04
0.4000E+01	0.6296E-04	0.5863E-04
0.4050E+01	0.6379E-04	0.5966E-04
0.4100E+01	0.6461E-04	0.6070E-04
0.4150E+01	0.6543E-04	0.6173E-04
0.4200E+01	0.6625E-04	0.6276E-04
0.4250E+01	0.6706E-04	0.6380E-04
0.4300E+01	0.6786E-04	0.6484E-04
0.4350E+01	0.6867E-04	0.6587E-04
0.4400E+01	0.6946E-04	0.6691E-04
0.4450E+01	0.7025E-04	0.6794E-04
0.4500E+01	0.7104E-04	0.6898E-04
0.4550E+01	0.7182E-04	0.7001E-04
0.4600E+01	0.7259E-04	0.7105E-04
0.4650E+01	0.7337E-04	0.7209E-04
0.4700E+01	0.7414E-04	0.7313E-04
0.4750E+01	0.7490E-04	0.7416E-04
0.4800E+01	0.7565E-04	0.7520E-04
0.4850E+01	0.7641E-04	0.7624E-04
0.4900E+01	0.7716E-04	0.7728E-04
0.4950E+01	0.7790E-04	0.7831E-04
0.5000E+01	0.7864E-04	0.7935E-04
0.5050E+01	0.7938E-04	0.8039E-04
0.5100E+01	0.8012E-04	0.8143E-04
0.5150E+01	0.8085E-04	0.8247E-04
0.5200E+01	0.8157E-04	0.8351E-04
0.5250E+01	0.8229E-04	0.8455E-04
0.5300E+01	0.8301E-04	0.8559E-04
0.5350E+01	0.8372E-04	0.8663E-04
0.5400E+01	0.8443E-04	0.8767E-04
0.5450E+01	0.8514E-04	0.8871E-04
0.5500E+01	0.8584E-04	0.8975E-04
0.5550E+01	0.8654E-04	0.9079E-04
0.5600E+01	0.8723E-04	0.9183E-04
0.5650E+01	0.8792E-04	0.9287E-04
0.5700E+01	0.8861E-04	0.9391E-04
0.5750E+01	0.8929E-04	0.9495E-04
0.5800E+01	0.8997E-04	0.9599E-04
0.5850E+01	0.9065E-04	0.9703E-04
0.5900E+01	0.9132E-04	0.9808E-04
0.5950E+01	0.9199E-04	0.9912E-04
0.6000E+01	0.9265E-04	0.1002E-03
0.6050E+01	0.9332E-04	0.1012E-03
0.6100E+01	0.9398E-04	0.1022E-03
0.6150E+01	0.9463E-04	0.1033E-03
0.6200E+01	0.9529E-04	0.1043E-03
0.6250E+01	0.9594E-04	0.1054E-03
0.6300E+01	0.9658E-04	0.1064E-03
0.6350E+01	0.9723E-04	0.1075E-03
0.6400E+01	0.9786E-04	0.1085E-03
0.6450E+01	0.9850E-04	0.1095E-03
0.6500E+01	0.9914E-04	0.1106E-03

0.6550E+01	0.9976E-04	0.1116E-03
0.6600E+01	0.1004E-03	0.1127E-03
0.6650E+01	0.1010E-03	0.1137E-03
0.6700E+01	0.1016E-03	0.1148E-03
0.6750E+01	0.1022E-03	0.1158E-03
0.6800E+01	0.1029E-03	0.1168E-03
0.6850E+01	0.1035E-03	0.1179E-03
0.6900E+01	0.1041E-03	0.1189E-03
0.6950E+01	0.1047E-03	0.1200E-03
0.7000E+01	0.1053E-03	0.1210E-03
0.7050E+01	0.1059E-03	0.1221E-03
0.7100E+01	0.1065E-03	0.1231E-03
0.7150E+01	0.1071E-03	0.1242E-03
0.7200E+01	0.1077E-03	0.1252E-03
0.7250E+01	0.1083E-03	0.1262E-03
0.7300E+01	0.1088E-03	0.1273E-03
0.7350E+01	0.1094E-03	0.1283E-03
0.7400E+01	0.1100E-03	0.1294E-03
0.7450E+01	0.1106E-03	0.1304E-03
0.7500E+01	0.1111E-03	0.1315E-03
0.7550E+01	0.1117E-03	0.1325E-03
0.7600E+01	0.1123E-03	0.1336E-03
0.7650E+01	0.1129E-03	0.1346E-03
0.7700E+01	0.1134E-03	0.1357E-03
0.7750E+01	0.1140E-03	0.1367E-03
0.7800E+01	0.1145E-03	0.1378E-03
0.7850E+01	0.1151E-03	0.1388E-03
0.7900E+01	0.1156E-03	0.1398E-03
0.7950E+01	0.1162E-03	0.1409E-03
0.8000E+01	0.1167E-03	0.1419E-03

This main program executes a Curve Fit using:

STEPIT for the curve fitting
STSET for initialization of STEPIT input parameters
MODEL for minimizing the current equation derived
from a "Charge-Sheet Model"
CSO for main Charge-sheet program
FUNCTION for the current equation

The user must supply:

1. IV data file in required format
2. Parameter file in required format
3. Initial Starting value file for mobility
and flat band voltage in each data set.

The user can request a copy of STEPIT from:

Quantum Chemistry Program Exchange
Indiana University
Bloomington, Indiana 47401

Authored by: J.P. Chandler
Department of Computing and Information Sciences
Oklahoma State University
Stillwater, Oklahoma 74074

The program CSFIT assumes that the fitting parameters
are flat band voltage and mobility with the flat band
voltage= $X(2i-1)$ and mobility= $X(2i)$ where $i=1,2,\dots$
...nvds=the total number of data sets and $2*nvds$ =total
number of fitting parameters. Thus, if 2 I-V data sets
are used with $X(1)=u_1$, $X(2)=fbv_1$, $X(3)=u_2$, and $X(4)=fbv_2$
the output file results would be as follows:

c1SUBROUTINE STEPIT. COPYRIGHT (C) 1965 J. P. CHANDLER

c INITIAL VALUES....

MASK	=	0	0	0	0
X	=	0.10000E+00	0.50000E+03	0.10000E+00	0.50000E+03
XMAX	=	0.10000E+36	0.10000E+36	0.10000E+36	0.10000E+36
XMIN	=	-0.10000E+36	-0.10000E+36	-0.10000E+36	-0.10000E+36
DELTX	=	0.10000E-02	0.50000E+01	0.10000E-02	0.50000E+01

c The final optimized values are given in corresponding order,
c i.e., vfb(1),mob(1),vfb(2),mob(2),.....vfb(i),mob(i).
c
c

```
implicit real*8 (a-h,o-z)
external model
dimension a(1000,3)
common /cstep/ x(20),xmax(20),xmin(20),deltx(20),delmn(20),
*err(20,21),fobj,nv,ntrac,matrx,mask(20),nfmax,nflat,jvary,
*nxtra,kflag,norep,kerfl,kw
common /cmod/ xm(1000),y(1000),npts
common /input/ npset(20),vds(20),nvds
real*4 vds,beta
common /mshape/ djun,ljun,lch
real*4 djun,ljun,lch
common /dopant/ nsd,nch
real*4 nsd,nch
common /bias/ vd,vs,vg,vsub,vfb
real*4 vd,vs,vg,vsub,vfb
common /gate/ tox,q0,kox,ksi
real*4 tox,q0,kox,ksi
common /sheet/ mustar,z,psib,lb,cox,psis0,psisl,n0,i0,id
real*4 mustar,lb,n0,i0,id,psib,cox,psis0,psisl,z
COMMON /NORM/ VT,VNORM,Q,NI,EPSO,EPS,LNORM,NNORM,tnorm,mu0
REAL*4 VT,VNORM,Q,NI,EPSO,EPS,LNORM,NNORM,tnorm,mu0
character*40 filin1,filin2,filin3,filout
write (6,*) 'Enter IV Data file'
read (5,5) filin1
5 format (a)
write (6,*) 'Enter Parameter file'
read (5,5) filin2
write (6,*) 'Enter Initial Starting Value file'
read (5,5) filin3
write (6,*) 'Enter Output file'
read (5,5) filout
open (unit=10,file=filin1,status='old')
open (unit=11,file=filin2,status='old')
open (unit=12,file=filin3,status='old')
open (unit=16,file=filout,status='new')
open (unit=17,file='plot.dat',status='new')
```

c
c Read from the Data file. The following
c format for the data file is required:

```
npts
a(j,1)   a(j,2)   a(j,3)
```

```
where:    npts=total number of iv points
          a(j,1)=source-to-drain voltage
          a(j,2)=gate voltage
          a(j,3)=drain current
```

```
read(10,*) npts
do 200 j=1,npts
read (10,*) a(j,1),a(j,2),a(j,3)
y(j)=a(j,3)
xm(j)=a(j,2)
200 continue
```



```

c           the function to be minimized depends.
c           xmax(i)=the upper limit on the value of x(i).
c           xmin(i)=the lower limit on the value of x(i).
c           deltx(i)=the initial step by which x(i) is varied.
c           delmn(i)=the lower limit (convergence tolerance)
c                   on the step size for x(i).
c           mask(i)=set nonzero if x(i) is not to be varied,
c                   but rather is to be held at its initial
c                   value.
c           ntrac=determines the amount of printout from STEPIT
c
c                   ntrac=1  to obtain trace during the
c                           minimization process
c
c                   ntrac=0  for initial and file output only
c
c                   ntrac=-1 for no output except error messages
c
c           STSET will set all the above to default values except ntrac
c
c           After SESET is called the initial starting values are read
c           in via the following format.
c
c           initial vfb(1)
c           initial mob(1)
c           initial vfb(2)
c           initial mob(2)
c           .
c           .
c           .
c           initial vfb(nvds)
c           initial mob(nvds)
c
c           call stset
c           nv=nvds*2
c           ntrac=0
c           do 203 j3=1,nv,2
c           read(12,*) x(j3),x(j3+1)
203      x(j3+1) = -x(j3+1)
c           do 204 j4=1,nv
204      delmn(j4)=1.0E-04
c           matrx=110
c
c           call STEPIT for least squares fit.
c
c           call stepit(model)
c
c           print results
c
c           k=1
c           do 2000 j=1,nvds
c           Vffit = -x(2*j-1)
c           write(16,1002) Vffit,x(2*j),vds(j),j
1002      format (' Vfb = ',lpe12.5,' Mu = ',Opf7.2,' Vd = ',f7.2,
1          ' Set ',i2,/,',          Vg          Id          Idcal')
c           write(17,*) npset(j)
c           imax=npset(j)
c           vd=vds(j)/vt

```

```

        vfb=-x(2*j-1)/vt
        mustar=x(2*j)/mu0
        do 1000 i=1,imax
            vg=xm(k)/vt
            call cs0
            write(16,1001) xm(k),y(k),id
1001         format (3e12.4)
            write(17,1001) vds(j),xm(k),id
            k=k+1
1000         continue
2000     continue

207     continue
        close(10)
        close(11)
        close(12)
        close(16)
        end

```

c
c
c
c
c

MODEL subroutine

```

subroutine model
implicit real*8 (a-h,o-z)
common /cstep/ x(20),xmax(20),xmin(20),deltx(20),delmn(20),
*err(20,21),fobj,nv,ntrac,matrx,mask(20),nfmax,nflat,jvary,
*nextra,kflag,norep,kerfl,kw
common /cmod/ xm(1000),y(1000),npts
common /input/ npset(20),vds(20),nvds
real*4 vds,beta
common /mshape/ djun,ljun,lch
real*4 djun,ljun,lch
COMMON /GATE/ TOX,Q0,KOX,KSI
REAL*4 KOX,KSI,tox,q0
common /dopant/ nsd,nch
real*4 nsd,nch
COMMON /NORM/ VT,VNORM,Q,NI,EPSO,EPS,LNORM,NNORM,tnorm,mu0
REAL*4 VT,VNORM,Q,NI,EPSO,EPS,LNORM,NNORM,tnorm,mu0
common /bias/ vd,vs,vg,vsub,vfb
real*4 vd,vs,vg,vsub,vfb
common /sheet/ mustar,z,psib,lb,cox,psis0,psisl,n0,i0,id
real*4 mustar,lb,n0,i0,id,psib,cox,psis0,psisl,z
real*4 ifun,nl
fobj=0.
k=1
    do 2000 j=1,nvds
        imax=npset(j)
        vd=vds(j)/vt
        vfb=-x(2*j-1)/vt
        mustar=x(2*j)/mu0
        do 1000 i=1,imax
            vg=xm(k)/vt
            call cs0
            fobj=fobj+(id/y(k)-1.0)**2
            k=k+1
1000         continue
2000     continue
return
end

```

c
c
c
c
c

CS0 Subroutine

```
subroutine cs0
common /mshape/ djun,ljun,lch
real*4 djun,ljun,lch
COMMON /GATE/ TOX,Q0,KOX,KSI
REAL*4 KOX,KSI,tox,q0
common /dopant/ nsd,nch
real*4 nsd,nch
COMMON /NORM/ VT,VNORM,Q,NI,EPSO,EPS,LNORM,NNORM,tnorm,mu0
REAL*4 VT,VNORM,Q,NI,EPSO,EPS,LNORM,NNORM,tnorm,mu0
common /bias/ vd,vs,vg,vsub,vfb
real*4 vd,vs,vg,vsub,vfb
common /sheet/ mustar,z,psib,lb,cox,psis0,psisl,n0,i0,id
real*4 mustar,lb,n0,i0,id,psib,cox,psis0,psisl,z
real*4 ifun,nl
beta = 1.0/vt
psib = vt*alog(nch)
lb = sqrt(ksi*eps0/q/(beta*nch*ni))
cox = kox*eps0/(TOX*LNORM)
vg1 = vg-vfb+q*beta*Q0/cox
bps0 = 2.0*beta*psib-2.0*alog(beta*sqrt(2.0)*q*nch*ni*lb/cox)
bps1 = bps0
bpsis = 1.0e10
if (vg1.lt.bps0) bpsis = bps0
if (vg1.le.bps0) goto 11
do 10 i=1,500
bps1 = bps0+alog(abs((vg1-bps1)**2/(1.+(bps1-1.0)/exp(bps1
1 -2.0*psib*beta))))
if (abs(bps1-bpsis).lt.1.e-4) goto 11
bpsis = bps1
10 continue
11 psis0=bps1/beta
n0=nch*ni*lb*sqrt(2.)*((bps1-1.0+(1./nch)**2*
1 exp(bps1))**0.5-(bps1-1.0)**0.5)
psisl = psis0+vd*vt
v0 = (q*nch*ni*lb/cox)**2
IF (VG1.LT. 1.0) GO TO 5000
psiss=vg1*vt+v0*beta-sqrt((v0*beta)**2+2.*v0*(vg1-1.0))
if (psisl.gt.psiss) psisl=psiss
nl = 0 )
if (psisl.eq.psiss) goto 13
h = 1.0
dpold = 1.0
do 12 i=1,100
nl = cox*(vg1*vt-psisl)/q-ni*nch*lb*sqrt(2.)*(beta*psisl-1.0)**0.5
if (nl.lt.1.0e-25) nl=1.0e-25
psisi=psis0+vd*vt+alog(nl/n0)/beta
delpsi=psisi-psisl
if (abs(delpsi).gt.vt) delpsi=vt*abs(delpsi)/delpsi
if (delpsi.eq.0.0) goto 12
if (dpold/delpsi.lt.0.0) h=h/2.0
psisl=psisl+h*delpsi
if (abs(delpsi).lt.1.0e-5) goto 13
dpold=delpsi
12 continue
30 13 id = ifun(psisl,lch)
```



```
if (ps.eq.psisl) i0=i00  
return  
end
```

U.S. DEPT. OF COMM. BIBLIOGRAPHIC DATA SHEET <i>(See instructions)</i>	1. PUBLICATION OR REPORT NO. NBSIR-85/3145	2. Performing Organ. Report No.	3. Publication Date November 1985
4. TITLE AND SUBTITLE CSFIT: A FORTRAN Program for Charge-Sheet Model Fitting of MOSFET Data			
5. AUTHOR(S) L. C. Witte			
6. PERFORMING ORGANIZATION <i>(If joint or other than NBS, see instructions)</i> NATIONAL BUREAU OF STANDARDS DEPARTMENT OF COMMERCE WASHINGTON, D.C. 20234		7. Contract/Grant No. Subtask X99QMXVA, Work Unit 00059	8. Type of Report & Period Covered
9. SPONSORING ORGANIZATION NAME AND COMPLETE ADDRESS <i>(Street, City, State, ZIP)</i> Defense Nuclear Agency Washington, DC 20305			
10. SUPPLEMENTARY NOTES <input type="checkbox"/> Document describes a computer program; SF-185, FIPS Software Summary, is attached.			
11. ABSTRACT <i>(A 200-word or less factual summary of most significant information. If document includes a significant bibliography or literature survey, mention it here)</i> <p>A FORTRAN program, CSFIT, has been developed for fitting an expression for the current-voltage (I-V) characteristics of a long-channel MOSFET to experimental I-V curves. The one-dimensional charge-sheet model developed by Brews provides the basis for the I-V characteristics. The I-V characteristics given by this model are optimized with respect to a set of experimental data using the flatband voltage and the mobility as the only adjustable parameters. The program is written so that multiple sets of I-V data can be fit simultaneously if desired. The user must supply, in specified formats, a current-voltage data file, a device parameter file, and a starting value file.</p>			
12. KEY WORDS <i>(Six to twelve entries; alphabetical order; capitalize only proper names; and separate key words by semicolons)</i> charge-sheet model; flatband voltage; I-V characteristics; mobility; MOSFET; parameter extraction			
13. AVAILABILITY <input checked="" type="checkbox"/> Unlimited <input type="checkbox"/> For Official Distribution. Do Not Release to NTIS <input type="checkbox"/> Order From Superintendent of Documents, U.S. Government Printing Office, Washington, D.C. 20402. <input checked="" type="checkbox"/> Order From National Technical Information Service (NTIS), Springfield, VA. 22161		14. NO. OF PRINTED PAGES 38	15. Price \$9.95

FEDERAL INFORMATION PROCESSING STANDARD SOFTWARE SUMMARY

01. Summary date Yr. Mo. Day 85 4 3			02. Summary prepared by (Name and Phone) L. C. Witte (301) 921-3621			03. Summary action New Replacement Deletion <input checked="" type="checkbox"/> <input type="checkbox"/> <input type="checkbox"/> Previous Internal Software ID			
04. Software date Yr. Mo. Day 85 4 3			05. Software title CSFIT: A FORTRAN Program for Charge-Sheet Model Fitting of MOSFET Data			07. Internal Software ID CSFIT			
06. Short title			08. Software type <input type="checkbox"/> Automated Data System <input checked="" type="checkbox"/> Computer Program <input type="checkbox"/> Subroutine/Module			09. Processing mode <input checked="" type="checkbox"/> Interactive <input checked="" type="checkbox"/> Batch <input type="checkbox"/> Combination			
10. Application area <table style="width: 100%; border: none;"> <tr> <td style="text-align: center; border: none;"><u>General</u></td> <td style="text-align: center; border: none;"><u>Specific</u></td> </tr> <tr> <td style="border: none;"> <input type="checkbox"/> Computer Systems Support/Utility <input checked="" type="checkbox"/> Scientific/Engineering <input type="checkbox"/> Bibliographic/Textual </td> <td style="border: none;"> <input type="checkbox"/> Management/Business <input type="checkbox"/> Process Control <input type="checkbox"/> Other </td> </tr> </table>			<u>General</u>	<u>Specific</u>	<input type="checkbox"/> Computer Systems Support/Utility <input checked="" type="checkbox"/> Scientific/Engineering <input type="checkbox"/> Bibliographic/Textual	<input type="checkbox"/> Management/Business <input type="checkbox"/> Process Control <input type="checkbox"/> Other	MOS Transistor Modeling		
<u>General</u>	<u>Specific</u>								
<input type="checkbox"/> Computer Systems Support/Utility <input checked="" type="checkbox"/> Scientific/Engineering <input type="checkbox"/> Bibliographic/Textual	<input type="checkbox"/> Management/Business <input type="checkbox"/> Process Control <input type="checkbox"/> Other								
11. Submitting organization and address National Bureau of Standards Gaithersburg, MD 20899				12. Technical contact(s) and phone C. L. Wilson (301) 921-3541					
13. Narrative A FORTRAN program, CSFIT, has been developed for fitting an expression for the current-voltage (I-V) characteristics of a long-channel MOSFET to experimental I-V curves. The one-dimensional charge-sheet model developed by Brews provides the basis for the I-V characteristics. The I-V characteristics given by this model are optimized with respect to a set of experimental data using the flatband voltage and the mobility as the only adjustable parameters. The program is written so that multiple sets of I-V data can be fit simultaneously if desired. The user must supply, in specified formats, a current-voltage data file, a device parameter file, and a starting value file.									
14. Keywords charge-sheet model; flatband voltage; I-V characteristics; mobility; MOSFET; parameter extraction									
15. Computer manufr and model DEC 11/780		16. Computer operating system VMS		17. Programing language(s) FORTRAN		18. Number of source program statements 484			
19. Computer memory requirements 40K		20. Tape drives 0		21. Disk/Drum units 1		22. Terminals 1			
23. Other operational requirements Requires local vector-oriented graphics									
24. Software availability Available <input checked="" type="checkbox"/> Limited <input type="checkbox"/> In-house only <input type="checkbox"/> C. L. Wilson (301) 921-3541 9-track magnetic tape			25. Documentation availability Available <input checked="" type="checkbox"/> Inadequate <input type="checkbox"/> In-house only <input type="checkbox"/> Title as in section 05 NBSIR-85/3145						
26. FOR SUBMITTING ORGANIZATION USE									

DTIC

END

44-886