

MICROCOPY RESOLUTION TEST CHART

2

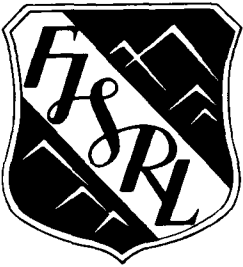

FRANK J. SEILER RESEARCH LABORATORY

FJSRL-TR-86-0001 ✓

MARCH 1986

AD-A166 307

ADVANCED LASER BASED INERTIAL
INSTRUMENT DEVELOPMENT

FINAL REPORT

DTIC
ELECTE
APR 7 1986
S B D

DTIC FILE COPY

MAJOR JAMES P. POTGE'

APPROVED FOR PUBLIC RELEASE;
DISTRIBUTION UNLIMITED.



PROJECT 2301-F1-71

AIR FORCE SYSTEMS COMMAND
UNITED STATES AIR FORCE

86 4 7 075

FJSRL-TR-86-0001

This document was prepared by the Guidance and Control Division, Directorate of Lasers and Aerospace Mechanics, Frank J. Seiler Research Laboratory, United States Air Force Academy, Colorado Springs, CO. The research was conducted under Project Work Unit Number 2301-F1-71, Advanced Laser Based Inertial Instrument Development (ALBIID). Major Salvatore R. Balsamo and Major James R. Rotge were the Project Scientists in charge of the work.

When U.S. Government drawings, specifications or other data are used for any purpose other than a definitely related government procurement operation, the government thereby incurs no responsibility nor any obligation whatsoever, and the fact that the government may have formulated, furnished or in any way supplied the said drawings, specifications or other data is not to be regarded by implication or otherwise, as in any manner licensing the holder or any other person or corporation or conveying any rights or permission to manufacture, use or sell any patented invention that may in any way be related thereto.

Inquiries concerning the technical content of this document should be addressed to the Frank J. Seiler Research Laboratory (AFSC), FJSRL/NH, USAF Academy, Colorado Springs, CO 80840-6528. Phone AC 303-472-3122.

This report has been reviewed by the Commander and is released to the National Technical Information Service (NTIS). At NTIS it will be available to the general public, including foreign nations.

This technical report has been reviewed and is approved for publication.

JAMES R. ROTGE, Major, USAF
Project Scientist

ALBERT J. ALEXANDER, Major, USAF
Director, Lasers & Aerospace Mechanics

JOHN H. PLETCHER, JR., Lt Col, USAF
Commander

Copies of this report should not be returned unless return is required by security considerations, contractual obligations, or notice on a specific document.

Printed in the United States of America. Qualified requesters may obtain additional copies from the Defense Technical Information Center. All others should apply to: National Technical Information Service
6285 Port Royal Road
Springfield, Virginia 22161

UNCLASSIFIED

SECURITY CLASSIFICATION OF THIS PAGE

AD-A166307

REPORT DOCUMENTATION PAGE

1a. REPORT SECURITY CLASSIFICATION UNCLASSIFIED		1b. RESTRICTIVE MARKINGS		
2a. SECURITY CLASSIFICATION AUTHORITY		3. DISTRIBUTION/AVAILABILITY OF REPORT Approved for public release; Distribution unlimited		
2b. DECLASSIFICATION/DOWNGRADING SCHEDULE				
4. PERFORMING ORGANIZATION REPORT NUMBER(S) FJSRL-TR-86-0001		5. MONITORING ORGANIZATION REPORT NUMBER(S)		
6a. NAME OF PERFORMING ORGANIZATION Frank J. Seiler Research Laboratory	6b. OFFICE SYMBOL (If applicable) FJSRL/NHG	7a. NAME OF MONITORING ORGANIZATION		
6c. ADDRESS (City, State and ZIP Code) USAF Academy Colorado Springs, CO 80840-6528		7b. ADDRESS (City, State and ZIP Code)		
8a. NAME OF FUNDING/SPONSORING ORGANIZATION	8b. OFFICE SYMBOL (If applicable)	9. PROCUREMENT INSTRUMENT IDENTIFICATION NUMBER		
8c. ADDRESS (City, State and ZIP Code)		10. SOURCE OF FUNDING NOS.		
		PROGRAM ELEMENT NO.	PROJECT NO.	
		TASK NO.	WORK UNIT NO.	
11. TITLE (Include Security Classification) Advanced Laser Based Inertial Instrument Development (U)		61102F	2301	
		FL	71	
12. PERSONAL AUTHOR(S) James R. Rotge ¹				
13a. TYPE OF REPORT Final	13b. TIME COVERED FROM Jan 84 to Mar 86	14. DATE OF REPORT (Yr., Mo., Day) 1986 March 24	15. PAGE COUNT 17	
16. SUPPLEMENTARY NOTATION				
17. COSATI CODES		18. SUBJECT TERMS (Continue on reverse if necessary and identify by block number) laser gyroscope, lock-in, frequency stabilization, laser clock, injection locking		
FIELD	GROUP			SUB GR.
1707	2005			2303
19. ABSTRACT (Continue on reverse if necessary and identify by block number) Active laser gyroscopes suffer from a lock-in phenomenon, a result of backscatter from the cavity optical elements, which limit their performance in the regime of near-zero rotation. The flip-flop gyro proposed and initially investigated under this effort shows potential for minimizing or avoiding this lock-in effect. The need for a high accuracy, inexpensive and reliable clock, suitable for avionics applications was the motivation for the laser clock proposed and studied during the course of this effort. Both devices require and deserve further investigation to properly demonstrate their utility.				
20. DISTRIBUTION/AVAILABILITY OF ABSTRACT UNCLASSIFIED/UNLIMITED <input type="checkbox"/> SAME AS RPT. <input checked="" type="checkbox"/> DTIC USERS <input type="checkbox"/>		21. ABSTRACT SECURITY CLASSIFICATION UNCLASSIFIED		
22a. NAME OF RESPONSIBLE INDIVIDUAL James R. Rotge ¹		22b. TELEPHONE NUMBER (Include Area Code) (303) 472-3122	22c. OFFICE SYMBOL FJSRL/NHG	

TABLE OF CONTENTS

	Page No.
INTRODUCTION	1
DISCUSSION	1
CONCLUSION	3
APPENDIX A	4
APPENDIX B	10

S DTIC
ELECTE **D**
APR 7 1986
B

Accession For	
NTIS GRA&I	<input checked="" type="checkbox"/>
DTIC TAB	<input type="checkbox"/>
Unannounced	<input type="checkbox"/>
Justification	
By _____	
Distribution/	
Availability Codes	
Dist	Avail and/or Special
A-1	

INTRODUCTION

This work unit consisted of work done in three areas: (1) design and implementation of a passive resonant ring laser gyroscope based upon a high-finesse resonant cavity; (2) high accuracy clock based upon stabilizing a He-Ne laser and using the inter-mode beat as a clock signal; and (3) the "flip-flop" gyro - an attempt to suppress the lock-in phenomenon present in active ring laser gyros by alternating the traveling wave direction within the ring cavity. The bulk of the work performed on this effort was in the latter two areas. Papers describing each of these three areas are included in this final report. Discussion of (1) above will not be included here as the subject was addressed in greater detail under Work Unit 2301-F1-68, "Large Passive Resonant Ring Laser Gyro Project."

DISCUSSION

Laser Clock - The goal of this effort was to develop an inexpensive yet accurate and hardy clock to be used in avionics systems. This device should require very little or no warm up time and the stated accuracy goal was one part in 10^8 .

The principle behind this avionics clock is the beat signal obtained by heterodyning the output of a He-Ne laser lasing in two longitudinal modes on the He-Ne gain curve at $\lambda = 633$ nm. By controlling the cavity optical path length the positions of the two modes on the gain curve can be held relatively stable. The cavity (effective) length can be controlled by various means including discharge current control, active and passive

thermal control and physical length control of the laser gain tube. The experiment was never completed due to the late availability of various components, especially the high speed detector necessary to sense the intermode beat frequency (~ 1 GHz). Additional details of this effort are provided by the paper, "High Accuracy Clock Using a Stabilized HeNe Laser," by S. Balsamo (Appendix A).

Flip-Flop Gyro - Active ring laser gyros exhibit a lock-in phenomenon at near zero rotation rates. This is due to the fact that both running waves (CW and CCW) are being amplified by a common He-Ne gain medium (at near zero rotation rates). This lock-in phenomenon is common to all coupled oscillators with similar resonant frequencies. In laser gyros now in commercial operation, the technique used to get around this lock-in effect is mechanical dither. Other lock-in avoidance or compensation schemes have been proposed and tried but with limited success. This research effort was to demonstrate a different approach to lock-in avoidance; that of causing the ring laser to lase in only one direction (CW or CCW) at a time. By introducing a fixed optical delay equal to the reciprocal of the switching frequency one could then beat the clockwise and counter clockwise running waves together on a detector; the resulting AC signal from the detector being proportional to the rotation rate (re Sagnac Effect) of the device.

The method used to alternately suppress the counter-running waves is discussed in the paper attached as Appendix B, "An Active Ring Laser Gyroscope Without Lock-in: Concept, Design, and Feasibility," by S. Balsamo. Additional work is required to fully understand the characteristics of the system as described in this paper.

CONCLUSION

Both the laser clock and flip-flop gyro efforts were discontinued prematurely. Major Balsamo retired from the Air Force and there was insufficient manpower to continue this work unit. There is interesting and potentially valuable experimental work to be performed to fully demonstrate both of these concepts. In the case of the laser clock, the basic question is how well can one lock the positions of the (two) longitudinal modes in the gain curve. A rough shot noise calculation for a typical device shows the minimum discernible frequency shift for a mode on the gain curve to be of order 10^{-3} Hz, and a more practical limit of 10 Hz or less. This calculation depends upon the assumption that the mode intensities are only functions of their positions on the gain curve. This implies a differential measurement to discriminate against intensity variations common to both modes. There is no fundamental reason why the laser clock would not work at the desired levels of precision (i.e., 1 part in 10^9). Whether this can be achieved in practice will depend upon frequency pulling effects and whether these can be controlled with sufficient precision.

Much remains to be done to fully demonstrate the flip-flop gyroscope. The transient behavior of the running wave laser at MHz switching speeds requires further investigation. High-Q cavities will have photon lifetimes approaching micro-seconds and may result in residual coupling of the running waves. This work might be advanced thru suitably managed AFIT graduate student efforts in terms of Master theses research. The transient behavior of a periodically switched running wave He-Ne ring oscillator would of itself be an interesting research topic.

APPENDIX A

HIGH ACCURACY CLOCK USING A STABILIZED HeNe LASER

by

Salvatore R. Balsamo, Major, USAF

Frank J. Seiler Research Laboratory (AFSC)
United States Air Force Academy
Colorado Springs, Colorado 80840

(303) 472-3122/AV 259-3122

The objective of this effort is to demonstrate that a relatively low cost (less than \$1,000.00) HeNe laser and simple electronics can provide a high accuracy (1 part in 10^{11}) timing source.

The timing device is a HeNe laser stabilized with two adjacent orthogonally polarized modes. The beat frequency between the adjacent modes (Δf) is used as the timing reference.

Analysis indicates that the technique discussed here is indeed possible. In addition, a technique similar to the one proposed here is now commonly used as a basis for stabilizing HeNe lasers^{1,2}.

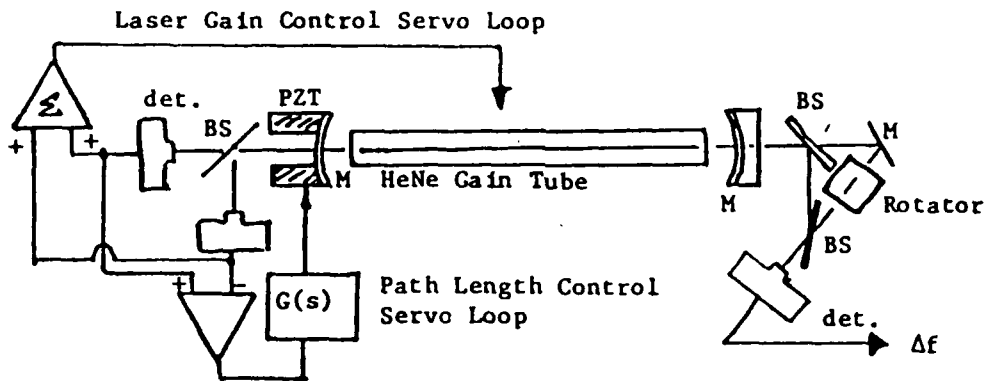

Figure 1. Clock Schematic Diagram

As shown in the figure above, Δf is the beat frequency between the two adjacent longitudinal modes. The laser length is approximately 15 cm allowing adjacent modes to be about 1 GHz. The beat frequency would be divided by 200 to provide the stable 5 MHz reference.

The problems can be seen by examining the adjacent modes as shown below in Figure 2.

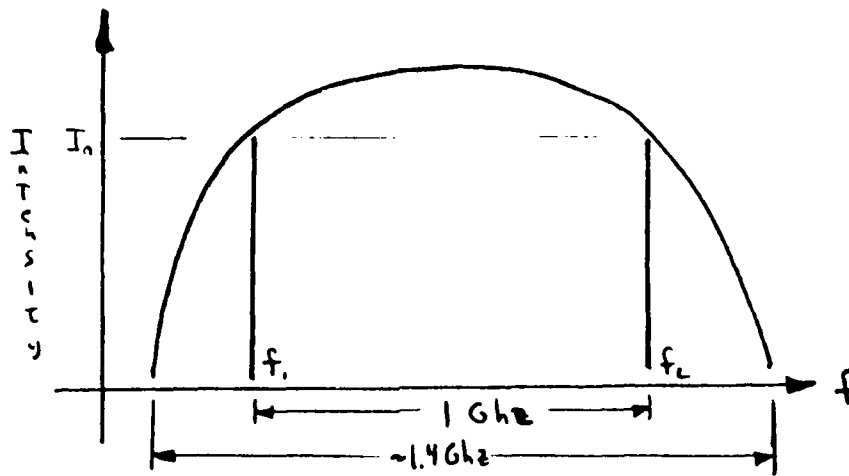

Figure 2. Placement of Modes on the HeNe Gain Curve

The two adjacent modes must be fixed on the gain curve. Any shift right or left will effect the 1 GHz beat frequency between the two adjacent modes because of variations in the index of refraction of the HeNe. Recall that the index of refraction is the first derivative of gain (to the first order), so that any drifting of the modes will effect the beat frequency. Locking the modes eliminates errors due to pulling and pushing. Similarly, any changes in gain will effect n and therefore the beat frequency (see Figure 3). A path length control loop such as the one shown in Figure 1 will fix the longitudinal modes on the gain curve.

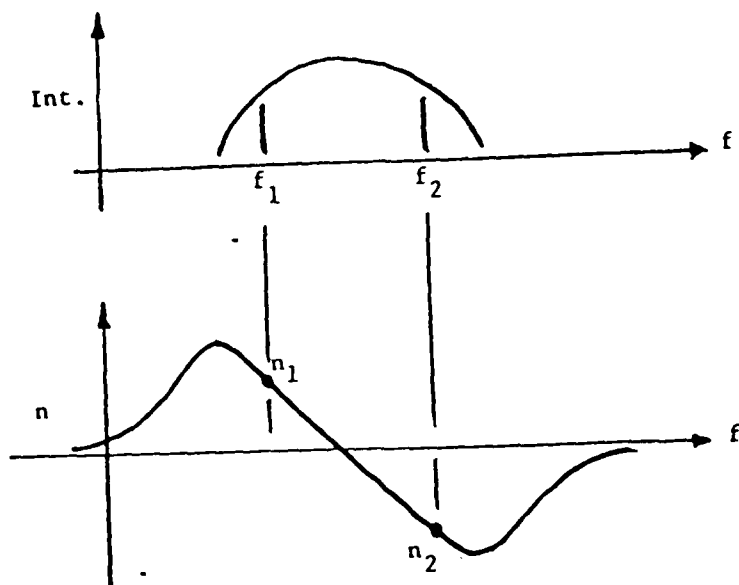

Figure 3. Laser Intensity and Index of Refraction versus Frequency

The technique is based upon the premise that the two adjacent longitudinal modes will be at orthogonal polarizations and thus be separable. This will be true if care is taken to insure that relatively equal losses for each mode are incurred in the gain tube, i.e., no Brewster windows, magnets, etc.

The approach is limited by the ability of the servo to fix the adjacent longitudinal modes. The servo is, in turn, limited in bandwidth by the mechanical noise in the laser. A very low noise, and very low thermal drift material, CERVIT, is used for the laser cavity.

The beat-frequency is derived by rotating the polarization of one of the adjacent modes and then sensing the interference of the two modes with a high frequency, low noise detector. A second method using a single polarizer at 45° to the two adjacent modes also yields a beat frequency but at a cost of a low signal to noise figure.

REFERENCES

1. R. Balhorn, et.al., "Frequency Stabilization of Internal Mirror Helium-Neon Lasers," Applied Optics, Vol II, No. 4, Apr 74.
2. Private conversation with Dr. Jan Hall, University of Colorado at Boulder and NBS, 24 Jan 83.
3. Lt Roger Facklam, "Ultra-Stable Laser Clock," presented at the 36th Annual Frequency Control Symposium.

APPENDIX B

AN ACTIVE RING LASER GYROSCOPE WITHOUT LOCK-IN:
CONCEPT, AND DESIGN

by

Salvatore R. Balsamo, Major, USAF

Frank J. Seiler Research Laboratory (AFSC)
United States Air Force Academy
Colorado Springs, Colorado 80840

(303) 472-3122/AV 259-3122

At present, the limiting factor in active ring laser performance is related to the various methods used to get around the lock-in phenomenon. This phenomenon is directly attributable to the fact that two frequencies (10^{14} Hz) very close to each other (generally less than 10^3 Hz) are being amplified by the same amplifier at the same time. What occurs is simply that the frequencies lock together. This presentation discusses an approach that eliminates this problem. Simply put, this research demonstrates that inertial rotation can be measured by an active ring laser gyroscope without the lasing having to take place in both directions at the same time.

This active ring laser gyroscope concept is described with the aid of the diagram below.

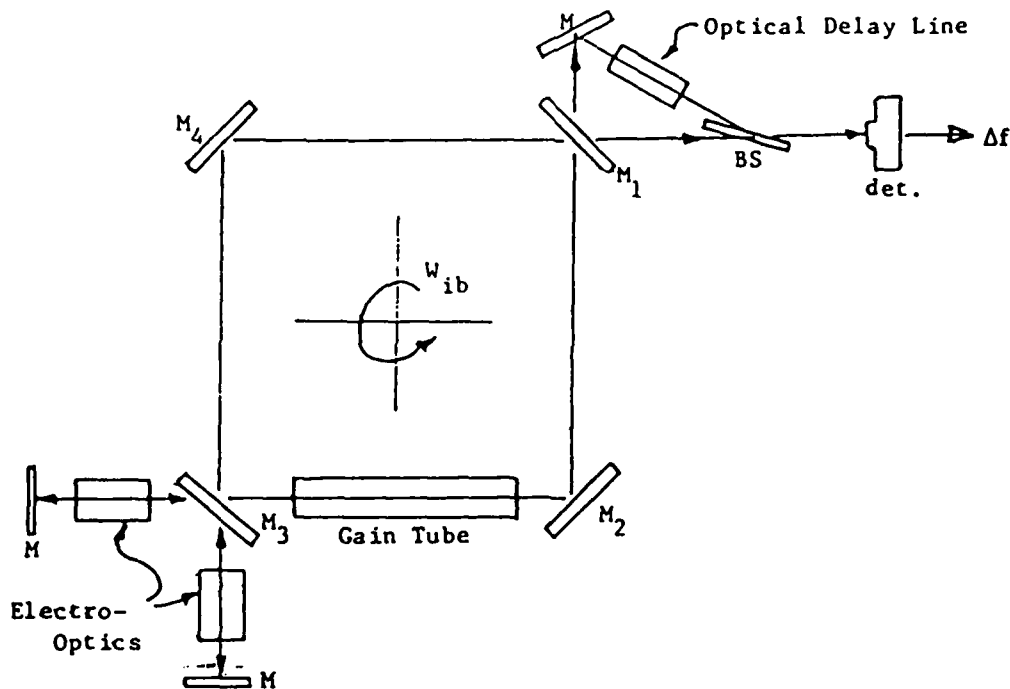

Figure 1. Gyroscope Schematic Diagram

In the diagram, a standard active ring laser is shown using the gain tube and the four mirrors M_1 , M_2 , M_3 , and M_4 .

First, the lasing action must be allowed to take place in only one direction at a time. This can be accomplished in several ways. In this diagram the technique used is that of reintroducing light into the cavity at the same frequency and polarization to cause destructive interference inside the cavity. Alternately, it can be viewed as introducing a directional loss in the cavity to stop lasing in either one direction or the other.

The electro-optic is used to rotate the polarization of the laser beam by 90° on reintroduction into the laser. This is accomplished by applying a $1/4$ wave voltage to the electro-optic. The polarization then changes from S (linear) to right hand circular. The reflection off the mirror then changes it to left hand circular which becomes p (linear) on passing through the electro-optic for the second time. Thus, with the electro-optic on the polarization is orthogonal to the polarization of the laser and therefore has no effect on the circulating beam (see Figure 2).

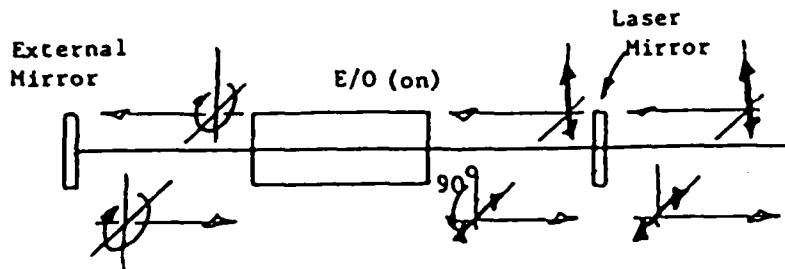

Figure 2. Polarization Changes for the System with the E/O "On"

With the E/O off there is no rotation and so the returning beam interferes and causes the lasing action to stop. In the ring laser there are two external E/O's. One for each direction which are alternately switched on and off.

If we look at the ring laser output at mirror M_1 in Figure 1, it would alternate as shown in Figure 3.

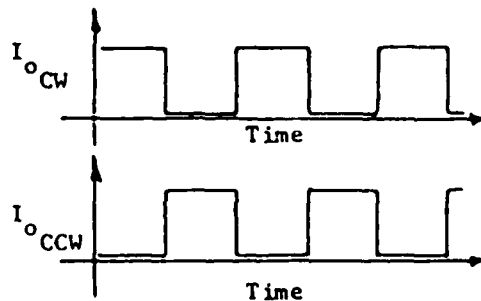

Figure 3. Output Beam Intensities at M_1

The lasing now takes place in only one direction at a time and so there will be no lock-in. There is no beat frequency at the detector because of the differing arrival times of the counter-rotating beams. To solve this problem a time delay must be introduced to time synchronize the two output beams. (See the optics at the mirror M_1 in Figure 1.) The delay time must be half the E/O switching time to produce the time synchronized output as shown below.

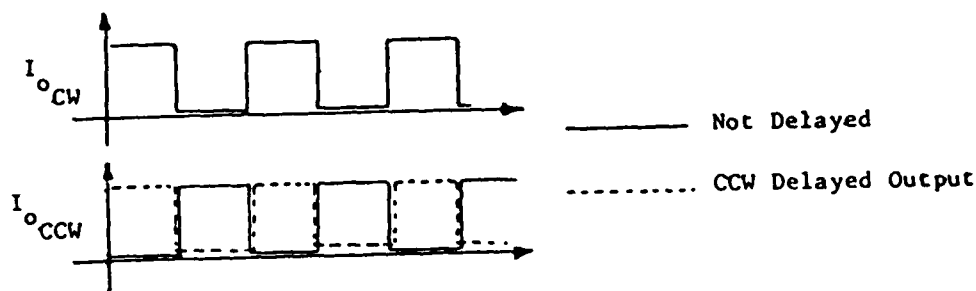

Figure 4. CCW Delayed Output in Synchronization with the CW Output

The delayed output in the CCW direction and the non-delayed output in the CW direction will not produce a beat frequency (f) at the detector.

The optical delay line is a length of glass (or plastic) fiber. For an E/O switching frequency of 1 MHz would require a half cycle delay of 0.5 usec. Using a glass fiber as the delay line implies a fiber length of 100 meters.

Recall that current active ring lasers sense beat frequencies on the order of 10 Hz or less in the face of mechanical and other noise sources of from 1 to 10 KHz on a carrier frequency of 5×10^{14} Hz! This measurement is possible because all noise sources are perfectly correlated in both the CW and CCW directions. This particular ring laser must retain the perfect noise correlation. This implies an E/O switching frequency of greater than 100 KHz, i.e., 10 times the highest noise frequency. The upper limit of the E/O switching frequency will be due to the cavity relaxation time. This will allow an E/O switching rate at least as high as 1 MHz. The output detector will not see the 100 KHz or greater switching frequency since it is only required to observe beat frequencies which are less than 20 KHz for most applications.

Experiments have already shown that the active ring laser can be controlled using the E/O's as described above and the use of fiber and/or a glass wedge as a time delay device for the frequencies involved here has already been demonstrated.

END
FILMED

5-86

DTIC