

AD-A106 322

UNDERWATER FACILITIES INSPECTIONS AND ASSESSMENTS AT  
NAVAL AIR STATION AL... (U) NAVAL FACILITIES ENGINEERING  
COMMAND WASHINGTON DC CHESAPEAKE.. SEP 82

1/2

UNCLASSIFIED

CHES/NAVFAC-FPO-1-82-(201

F/G 13/2

NL

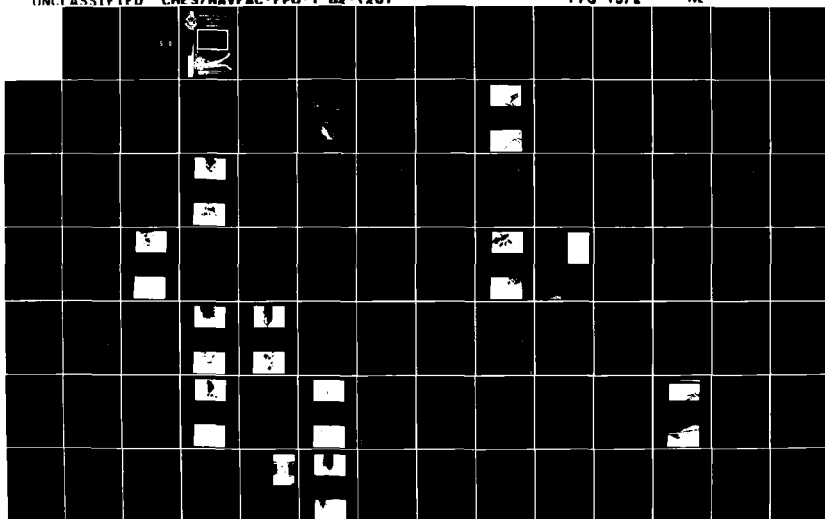

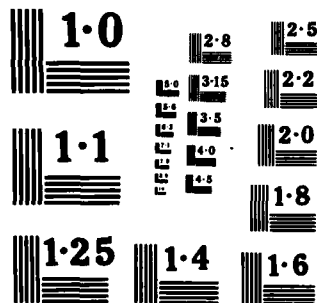

AD-A166 322

DTIC ACCESSION NUMBER

PHOTOGRAPH THIS SHEET

1

INVENTORY

UNDERWATER FACILITIES  
INSPECTIONS & ASSESSMENTS

LEVEL

NAVAL AIR STATION  
ALAMEDA, CALIFORNIA  
FPO-1-82(20)

DOCUMENT IDENTIFICATION

DISTRIBUTION STATEMENT A

Approved for public release  
Distribution Unlimited

DISTRIBUTION STATEMENT

ACCESSION FOR

NTIS GRA&I

DTIC TAB

UNANNOUNCED

JUSTIFICATION

\*Original contains color  
plates: All DTIC reproductions  
will be in black and  
white\*

DTIC  
SELECTED  
APR 16 1986  
S D

DATE ACCESSIONED

BY

DISTRIBUTION /

AVAILABILITY CODES

DIST

AVAIL AND/OR SPECIAL

A-1

DISTRIBUTION STAMP



DATE RETURNED

86 4 16 038

DATE RECEIVED IN DTIC

REGISTERED OR CERTIFIED NO.

PHOTOGRAPH THIS SHEET AND RETURN TO DTIC-DDAC

**UNDERWATER FACILITIES  
INSPECTIONS  
&  
ASSESSMENTS**



AD-A166 322



**UNDERWATER FACILITIES  
INSPECTIONS  
AND  
ASSESSMENTS  
AT**

**NAVAL AIR STATION  
ALAMEDA, CALIFORNIA**

FILE COPY  
Do Not Remove

**FPO-1-82-(20)    SEPTEMBER 1982**

**PERFORMED FOR:**

**OCEAN ENGINEERING AND CONSTRUCTION PROJECT OFFICE  
CHESAPEAKE DIVISION  
NAVAL FACILITIES ENGINEERING COMMAND  
WASHINGTON, D.C. 20374**

**BY:**

**UNDERWATER CONSTRUCTION TEAM TWO  
PORT HUENEME, CALIFORNIA 93043**

**CONSULTANT:**

**CHILDS ENGINEERING CORPORATION  
MEDFIELD, MASSACHUSETTS 02052**

**UNDER:**

**CONTRACT N62477-81-C-0448  
TASK 4**

Unclassified

SECURITY CLASSIFICATION OF THIS PAGE

REPORT DOCUMENTATION PAGE

1a. REPORT SECURITY CLASSIFICATION

Unclassified

1b. RESTRICTIVE MARKINGS

2a. SECURITY CLASSIFICATION AUTHORITY

3. DISTRIBUTION AVAILABILITY OF REP.  
Approved for public release;  
distribution is unlimited

2b. DECLASSIFICATION/DOWNGRADING SCHEDULE

4. PERFORMING ORGANIZATION REPORT NUMBER

5. MONITORING ORGANIZATION REPORT #  
FPO-1-82(20)

6a. NAME OF PERFORM. ORG. 6b. OFFICE SYM  
Childs Engineering Corp.

7a. NAME OF MONITORING ORGANIZATION  
Ocean Engineering  
& Construction  
Project Office  
CHESNAVFACENGCOM

6c. ADDRESS (City, State, and Zip Code)  
Medfield, MA 02052

7b. ADDRESS (City, State, and Zip )  
BLDG. 212, Washington Navy Yard  
Washington, D.C. 20374-2121

8a. NAME OF FUNDING ORG. 8b. OFFICE SYM

9. PROCUREMENT INSTRUMENT INDENT #  
N62477-81-C-0448, Task 4

8c. ADDRESS (City, State & Zip)

10. SOURCE OF FUNDING NUMBERS  
PROGRAM PROJECT TASK WORK UNIT  
ELEMENT # # # ACCESS #

11. TITLE (Including Security Classification)

Underwater Inspection & Assessments at Naval Air Station Alameda, California

12. PERSONAL AUTHOR(S)

13a. TYPE OF REPORT

13b. TIME COVERED  
FROM TO

14. DATE OF REP. (YMMDD) 15. PAGES  
82-09 69

16. SUPPLEMENTARY NOTATION

17. COSATI CODES  
FIELD GROUP SUB-GROUP

18. SUBJECT TERMS (Continue on reverse if nec.)  
Underwater inspection, Mooring inspection  
Naval Air Station Alameda, CA

19. ABSTRACT (Continue on reverse if necessary & identify by block number)  
The objective of the Underwater Facility Assessments conducted at te Naval Air Station in Alameda, California is to provide a generalized structural condition report of certain facilities within the Activity. The facilities are Piers 1, 2, 3, 4, Wharves 1 and 2, and the bulkhead at East-West (Con't)

20. DISTRIBUTION/AVAILABILITY OF ABSTRACT 21. ABSTRACT SECURITY CLASSIFICATION  
SAME AS RPT.

22a. NAME OF RESPONSIBLE INDIVIDUAL  
Jacqueline B. Riley  
DD FORM 1473, 84MAR

22b. TELEPHONE 22c. OFFICE SYMBOL  
202-433-3881

SECURITY CLASSIFICATION OF THIS PAGE

BLOCK 19 (Con't)

Taxiway. Each facility was inspected by a team of divers from Underwater Construction Team Two using visual/tactile, non-destructive techniques. Typical and critical elements were photo-documented.

The conditions of the facilities range from poor to excellent.

Pier 3 and Wharves 1 and 2 are in very good condition. No repairs are recommended for these facilities.

Piers 2 and 4, and the Bulkhead are generally in good condition but some deterioration was observed and minor repairs are recommended for these facilities.

Pier 1 is in poor condition. Presently vehicular traffic is restricted from the pier. We recommend that this restriction remain in force and that dead load on the pier be minimized. It is reported that the pier is due to be repaired or replaced in the mid-1980's. We recommend that this schedule be adhered to.

## EXECUTIVE SUMMARY

The objective of the Underwater Facility Assessments conducted at the Naval Air Station in Alameda, California is to provide a generalized structural condition report of certain facilities within the Activity. The facilities are Piers 1, 2, 3, 4, Wharves 1 and 2, and the bulkhead at East-West Taxiway. Each facility was inspected by a team of divers from Underwater Construction Team Two using visual/tactile, non-destructive techniques. Typical and critical elements were photo-documented.

The conditions of the facilities range from poor to excellent.

Pier 3 and Wharves 1 and 2 are in very good condition. No repairs are recommended for these facilities.

Piers 2 and 4, and the Bulkhead are generally in good condition but some deterioration was observed and minor repairs are recommended for these facilities.

Pier 1 is in poor condition. Presently vehicular traffic is restricted from the pier. We recommend that this restriction remain in force and that dead load on the pier be minimized. It is reported that the pier is due to be repaired or replaced in the mid-1980's. We recommend that this schedule be adhered to.

Refer to the following Executive Summary Table for an overview of each facility's construction and recommendations.

NAVAL AIR STATIONALAMEDA, CALIFORNIAEXECUTIVE SUMMARY TABLE

<u>Facility</u>	<u>Year Built</u>	<u>Total No. of Piles/ Lin. Ft. of Bulkhead</u>	<u>Size (lxw) (ft.)</u>	<u>Structures</u>
Pier 3	1945 ▲	4440 / 0	1355 x 150	20" square pre-cast concrete piles.
Wharf No. 2	1945 ▶	210 / 0	573 x 45	20" square pre-cast concrete piles.
Pier 2	1941 Enlarged 1974 ✱	1006 / 0	1211 x 80	20" square pre-cast concrete pi 18" square pre-stressed concret piles.
Wharf No. 1	1941 ▶ Enlarged 1945	526 / 0	744 x 90	20" square pre-cast concrete piles.
Pier 1	1937 ▲	0 / 1350	650 x 50	Steel sheet pile
Bulkhead	1939 ▲	0 / 3010	N/A	Steel sheet pile concrete encased
Pier 4	1953 ✱	48 / 0	160 x 5' to 15'	Treated timber piles.

AIR STATION

A, CALIFORNIA

THE SUMMARY TABLE

<u>Structures</u>	<u>Recommendations</u>	<u>Est. Cost of Recommendations (thousands)</u>
' square pre-st concrete piles.	1) Re-inspect in 5 years.	N/A
' square pre-st concrete piles.	1) Re-inspect in 5 years.	N/A
' square pre-st concrete piles,	1) Repair severely damaged piles by driving 2 sister piles and casting a new cap.	\$11
' square pre-stressed concrete piles.	2) Jacket heavily spalled piles in concrete.	\$16
	3) Re-inspect after construction and 5 years thereafter.	
' square pre-st concrete piles.	1) Re-inspect in 5 years.	N/A
el sheet piles	1) Refer to Section 4.5.4 Repair by driving new steel sheet pile wall.	\$5400
el sheet piles, concrete encased	1) Repair spalled concrete wall cap.	\$18
	2) Fill in front of bulkhead	\$43
	3) Re-inspect after construction and 5 years thereafter	
eated timber piles.	1) Replace damaged pile.	\$4
	2) Refasten, re-position and shim piles.	\$1.5
	3) Backfill exposed piles at mudline.	\$5
	4) Re-inspect after construction and 5 years thereafter	

TABLE OF CONTENTS

	<u>PAGE</u>
Executive Summary	i
Section 1.0 INTRODUCTION . . . . .	1-1
1.1 Report Content . . . . .	1-2
Section 2.0 ACTIVITY DESCRIPTION . . . . .	2-1
2.1 Location of Activity . . . . .	2-1
2.2 Existing Facilities . . . . .	2-1
2.3 Facilities Inspected . . . . .	2-2
Section 3.0 INSPECTION PROCEDURE . . . . .	3-1
3.1 Level of Inspection . . . . .	3-1
3.2 Inspection Procedure . . . . .	3-1
3.3 Inspection Equipment . . . . .	3-4
Section 4.0 FACILITIES INSPECTED . . . . .	4-1
4.1 Pier 3 . . . . .	4-5
4.1.1 Description . . . . .	4-5
4.1.2 Observed Inspection Condition . . . . .	4-11
4.1.3 Structural Condition Assessment . . . . .	4-12
4.1.4 Recommendations . . . . .	4-12
4.2 Wharf 2 . . . . .	4-13
4.2.1 Description . . . . .	4-13
4.2.2 Observed Inspection Condition . . . . .	4-15
4.2.3 Structural Condition Assessment . . . . .	4-16
4.2.4 Recommendations . . . . .	4-16
4.3 Pier 2 . . . . .	4-17
4.3.1 Description . . . . .	4-17
4.3.2 Observed Inspection Condition . . . . .	4-20
4.3.3 Structural Condition Assessment . . . . .	4-20
4.3.4 Recommendations . . . . .	4-21
4.4 Wharf 1 . . . . .	4-22
4.4.1 Description . . . . .	4-22
4.4.2 Observed Inspection Condition . . . . .	4-25
4.4.3 Structural Condition Assessment . . . . .	4-25
4.4.4 Recommendations . . . . .	4-26

TABLE OF CONTENTS (Cont'd.)

		<u>PAGE</u>
4.5	Pier 1 . . . . .	4-27
4.5.1	Description . . . . .	4-27
4.5.2	Observed Inspection Condition . . . . .	4-29
4.5.3	Structural Condition Assessment . . . . .	4-30
4.5.4	Recommendations . . . . .	4-31
4.6	Bulkhead . . . . .	4-32
4.6.1	Description . . . . .	4-32
4.6.2	Observed Inspection Condition . . . . .	4-34
4.6.3	Structural Condition Assessment . . . . .	4-35
4.6.4	Recommendations . . . . .	4-36
4.7	Pier 4 . . . . .	4-37
4.7.1	Description . . . . .	4-37
4.7.2	Observed Inspection Condition . . . . .	4-39
4.7.3	Structural Condition Assessment . . . . .	4-40
4.7.4	Recommendations . . . . .	4-41

APPENDIX

LIST OF FIGURES

<u>Figure</u>	<u>Title</u>	<u>Page</u>
1	Location Map . . . . .	2-3
2	Facilities Location Map . . . . .	2-4
3	Inspection Path . . . . .	3-3
4	Pile Condition . . . . .	4-3
5	Pile Condition . . . . .	4-4
6 thru 10	Pier 3 Pile Plan & Pile Conditions . . . . .	4-6 thru 10
11	Wharf 2 " " " " . . . . .	4-14
12 & 13	Pier 2 " " " " . . . . .	4-18, 19
14 & 15	Wharf 1 " " " " . . . . .	4-23, 24
16	Pier 1 " " " " . . . . .	4-28
17	Bulkhead Plan & Elevation . . . . .	4-33
18	Pier 4 Pile Plan & Pile Conditions . . . . .	4-38

LIST OF PHOTOGRAPHS

<u>Photo No.</u>	<u>Description</u>	<u>Follows Page</u>
1	Aerial view of Piers 1, 2 and 3; Wharves 1 and 2; and the Bulkhead adjacent to Parking Apron No. 4 . . . . .	2-4
2	Aerial view of Pier 4 . . . . .	2-4
3	Pier 3, Pile V, Bent 86, Elevation 102. Base of pile jacket. Note clear definition of pile chamfer edges illustrating sound concrete . . . . .	4-11
4	Pier 3, Pile A, Bent 103. Elevation 85±. Typical marine growth including mussels, sponges and hair-like algae . . . . .	4-11
5	Wharf 2, Pile A, Bent 25, Elevation 102.0. Spall at bottom of concrete jacket exposing pile . . . . .	4-15
6	Wharf 2, Pile B, Bent 15, Elevation 102.0. Typical marine growth at base of pile jacket . . . . .	4-15
7	Wharf 2, Pile B, Bent 1, Elevation 98.0. Typical band cleaned location for Level I inspection . . . . .	4-15
8	Pier 2, Pile A, Bent 131, Elevation 96.0. Spalled concrete at pile corner. Vertical and horizontal cracks. Pile severely damaged . . . . .	4-20
9	Pier 2, Pile A, Bent 130, Elevation 96.0. Vertical and horizontal cracks. Pile severely damaged . . . . .	4-20
10	Pier 2, Pile A, Bent 133, Elevation 99.0. Area of band cleaning and light spalling of pile corner . . . . .	4-20
11	Pier 2, Pile B, Bent 124, Elevation 95.0. Area of light spalling on pile face. Note exposed aggregate . . . . .	4-20
12	Wharf 2, Pile A, Bent 11, Elevation 95.0. Cleaned area at pile corner. Note distinct chamfer edges indicating sound concrete . . . . .	4-25

LIST OF PHOTOGRAPHS (Cont'd.)

<u>Photo No.</u>	<u>Description</u>	<u>Follows Page</u>
13	Wharf 2, Pile A, Bent 11, Elevation 95.0. Light spalling at pile corner . . . . .	4-25
14	Pier 1, Cell #23, south side. Elevation 95.0. 8" Ø hole in steel sheet pile. Note gravel fill within cell . . . . .	4-29
15	Pier 1, Typical corrosion node . . . . .	4-29
16	Pier 1, Typical condition of steel sheet piles at the mudline . . . . .	4-30
17	Pier 1, Typical Corrosion hole in sheet pile knuckle . . . . .	4-30
18	Bulkhead, Typical condition of concrete encasement with steel sheet piles exposed at base . . . . .	4-34
19	Bulkhead, Overview of Bulkhead. Note spalling at edge of concrete cap . . . . .	4-34
20	Pier 4, Typical displaced pile head. Similar conditions found Pile A, Bents 4, 6 and 7 of the Main Pier . . . . .	4-39
21	Pier 4, Typical condition of concrete jacket. Note zipper for closing fabric forms . . . . .	4-39
22	Pier 4, Typical marine borer trench found in some of the newer piles near the mudline, Southwest pile, Dolphin No. 3 . . . . .	4-39

This report is a product of the Underwater Facilities Inspection Program conducted by the Ocean Engineering and Construction Project Office (FPO-1), Chesapeake Division (CHESDIV), Naval Facilities Engineering Command (NAVFAC). The Underwater Facilities Inspection Program falls under the NAVFAC Specialized Inspection Program. Managed and executed by CHESDIV, the program is intended to be responsive to the needs of the Fleet as far as inspection of waterfront facilities.

Mandated under Government Contract No. N62477-81-C-0448, this project entails technical and engineering services for the inspection, damage and deterioration assessment, repair analysis and cost estimates for repairs for the submerged portions of selected Naval Waterfront Facilities. The inspection is usually conducted or managed by on-site structural diver engineers.

For this inspection, responsibility for the various aspects of the project was shared among several organizational groups. The U. S. Naval Underwater Construction Team Two (UCT-2) performed the underwater inspection and data collection. A representative from CHESDIV provided general technical direction for the whole project and acted as liaison among the Naval Air Station, UCT-2, CHESDIV and the consultant. Representatives from Childs Engineering Corporation, also provided on-site technical and engineering support to UCT-2, oversaw the acquisition of field notes and measurements, and performed limited underwater inspection services in order to become familiar with general conditions and secure photographic documentation. Using the data and documentation thus collected, personnel at Childs Engineering Corporation prepared this Underwater Facilities Inspection and Assessment Report.

## 1.1 REPORT CONTENT

Included in this report are a description of existing facilities, the inspection procedures, the results of the inspection, the analysis of the findings, and all relevant drawings and photos. The results of the inspection of each facility are divided into four categories: a description of the facility, observed conditions, structural assessment, and recommendations. Included in the recommendations are cost estimates (based on current local prices) for any repair work, (see Appendix). Calculations for the structural assessment and recommendations are found in the Appendix.

The purpose of this section is to provide a general description of the Naval Air Station in Alameda, California. Included in this section are descriptions of the Naval Air Station's location and existing facilities. The information is provided to aid in identification of the facility and to support all considerations necessary to accurately assess the condition of facilities inspected under this task.

### 2.1 LOCATION OF ACTIVITY

NAS Alameda is located on the west end of the City of Alameda in Alameda County, California (see Figure 1). It is bounded on the north by the City of Oakland and on the south and west by San Francisco Bay. It is at the geographic center of the San Francisco-Oakland Standard Metropolitan area. This area is roughly divided into two sectors. San Francisco and San Mateo Counties make up the portion known as the West Bay. The portion with which NAS Alameda is most concerned is the East Bay, which is comprised of Alameda and Contra Costa Counties. (Reference NAS Alameda Master Plan)

### 2.2 EXISTING FACILITIES

NAS Alameda is the only port in Northern California with a 40 foot plus project depth (mean lower low water) required for berthing CV/CVN class ships. It serves as one of only two deployment points for aircraft carriers on the West Coast. The three major piers total 6,120 feet of berth and offer the best pier facilities for Navy ships in the San Francisco Bay Area. NAS Alameda also has the only pier facilities in the Central Bay Area capable of handling a limited quantity of ordnance. For this reason and the deep

water capability, submarines utilize the Naval Air Station to off-load and load their torpedoes before entering and leaving Mare Island Naval Shipyard. (Reference NAS Alameda Master Plan)

### 2.3 FACILITIES INSPECTED

The facilities inspected under this contract at the NAS Alameda include Piers Nos. 1, 2, 3 and 4, Wharves 1 and 2 and the Bulkhead adjacent to Parking Apron No. 4. (See Figure 2 and Photos 1 and 2)

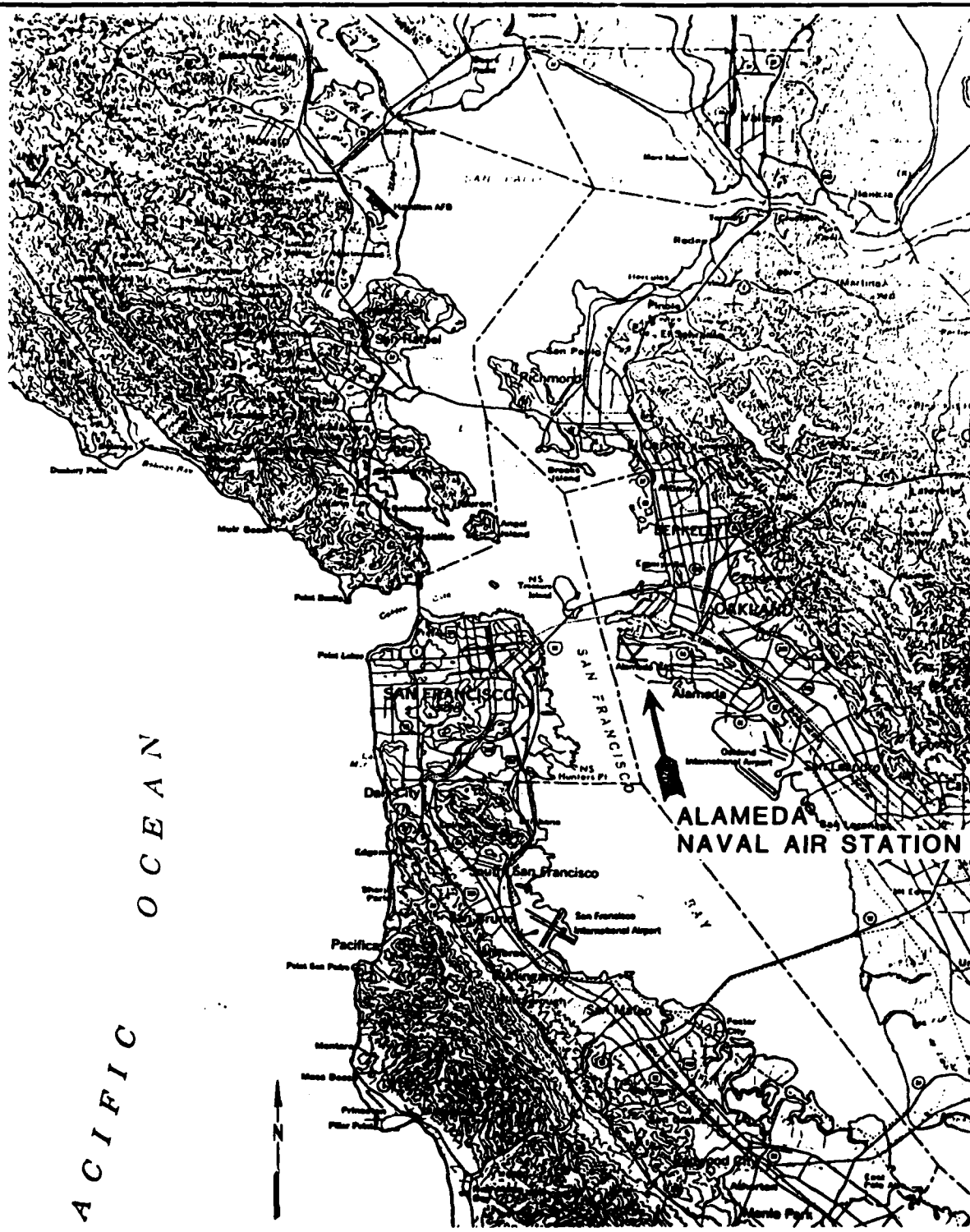

PACIFIC OCEAN

ALAMEDA NAVAL AIR STATION

**NOTE:**  
REFERENCE TAKEN FROM NAS ALAMEDA MASTER PLAN.

<p>GRAPHIC SCALE</p>	<p>CHILDS ENGINEERING CORPORATION BOX 333 MEDFIELD, MA</p>	<p>CHESAPEAKE DIVISION NAVAL FACILITIES ENGINEERING COMMAND WASHINGTON, D C</p>	<p>FIG. NO <b>1</b></p>
	<p>NAVAL AIR STATION ALAMEDA, CA <b>LOCATION PLAN</b></p>		

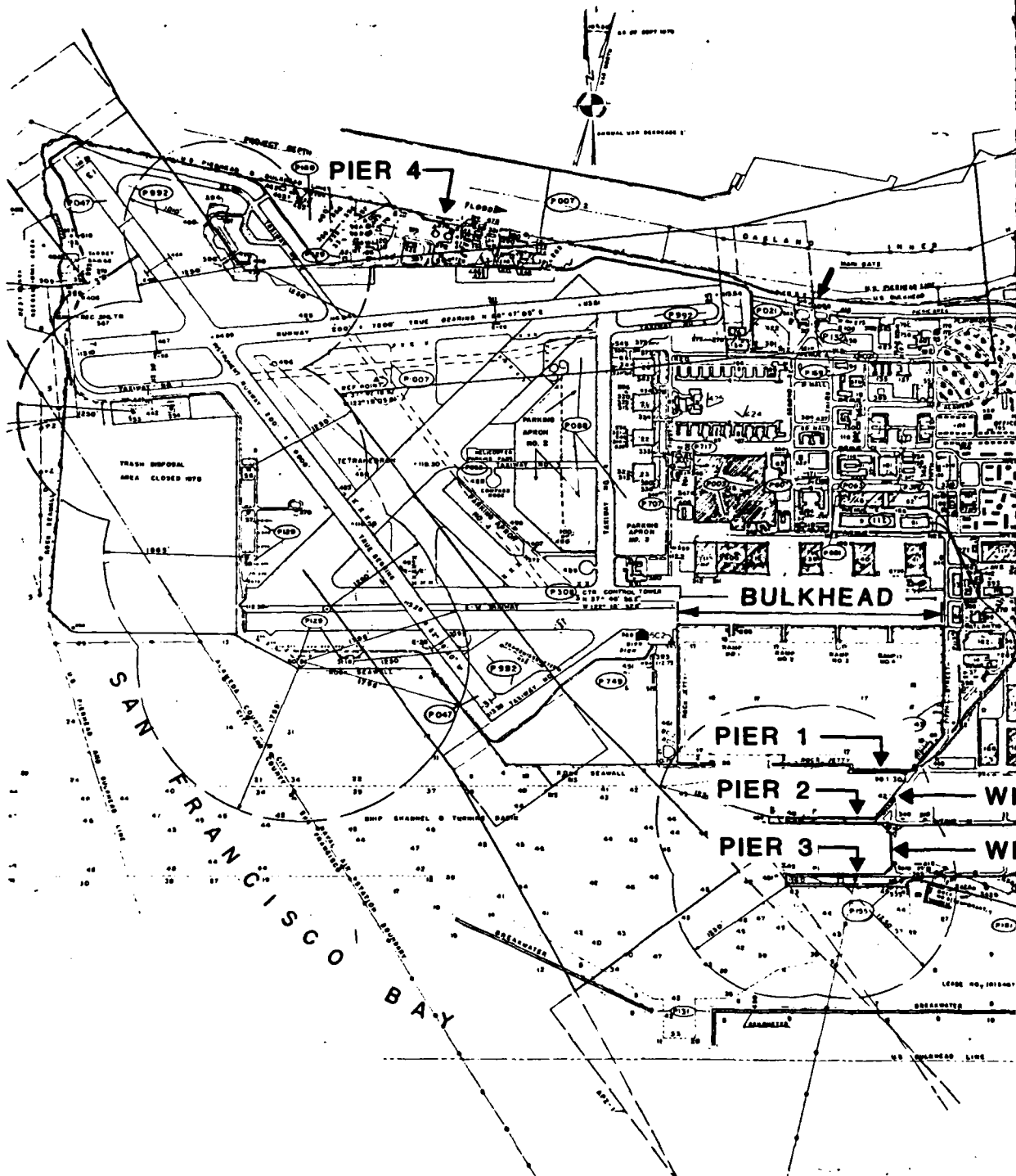

NOTE:  
 REFERENCE TAKEN FROM  
 NAVFAC DWG NO. 638456.

1



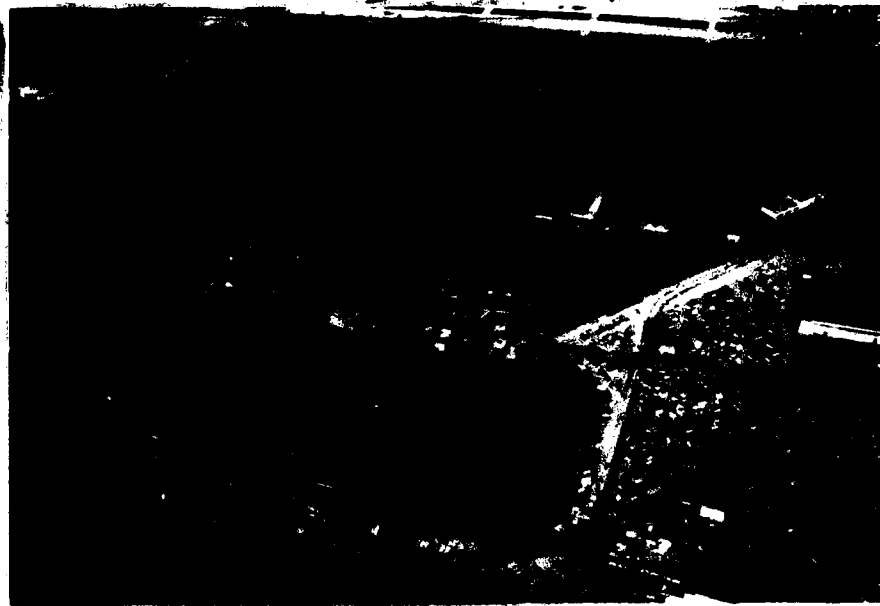
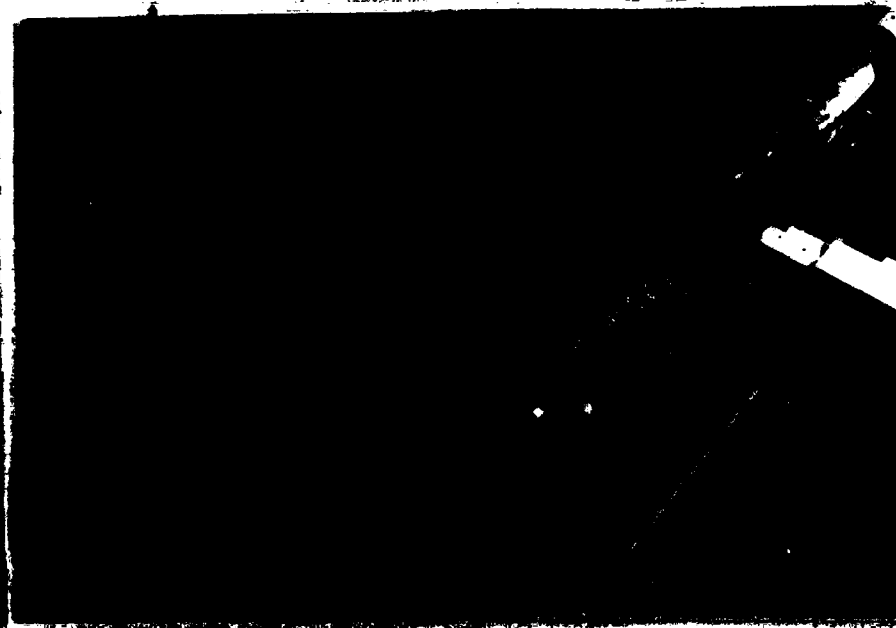

PHOTO #1: Aerial view of Piers 1, 2  
and 3; Wharves 1 and 2; and  
the Bulkhead adjacent to  
Parking Apron No. 4.

PHOTO #2: Aerial view of Pier 4



Between September 13 and September 24, 1982, the U. S. Navy's UCT-2 performed an on-site underwater inspection of selected facilities within the U. S. Naval Air Station, Alameda, California. UCT-2 provided diving assets and acquired field data to be incorporated into field notes. An engineer from Childs Engineering Corporation provided technical direction to UCT-2 and fully documented the inspection data acquired through UCT-2.

Between September 25 and September 28, two engineers from Childs Engineering Corporation performed some limited on-site underwater inspection work. The level of inspection to be performed, the type of structure being inspected, actual on-site conditions and past experience, combined with a thorough knowledge of engineering theory, dictated the inspection procedures that were followed.

### 3.1 LEVEL OF INSPECTION

The inspection techniques used had to be sufficient to yield information necessary to make a general condition assessment of the supporting structure of each facility, identify any areas that were mechanically damaged or in advanced states of deterioration, and formulate repair and maintenance recommendations and cost estimates. In general, this meant utilizing visual/tactile inspection techniques, accompanied by occasional external measurements employing such instruments as a scale, calipers or ultrasonic steel thickness gauge, where appropriate. Photographic documentation of typical as well as notable or unusual conditions was also obtained.

### 3.2 INSPECTION PROCEDURE

The scope of work for this portion of the underwater inspection program required that seven (7) facilities at the Naval Air Station,

Alameda be inspected. There were varying degrees of inspection. Levels I, II and III inspections were applied appropriately throughout each facility. The Level I inspection is a visual/tactile inspection of the full length of the exposed pile (see Figure 3). A level II inspection involves a visual/tactile inspection along the full length of the pile along with band cleaning at two elevations. Generally the band cleaning was executed at mean low water or if the pile was jacketed, it was band cleaned just below the jacket; the second elevation for band cleaning was at mid-depth. The Level III inspection was performed on the steel sheet pile structures. This involved the use of non-destructive methods to measure the thickness of the steel.

Due to the field conditions encountered, the degree of inspection varied and involved one or more of the above-mentioned inspection levels. On Pier 4 a Level I inspection was performed on all piles. On Pier 3 all perimeter piles and every pile in every 10th bent were inspected in accordance with a Level I inspection. Also a Level II inspection was performed on approximately 5% of the piles. On Pier 2 and Wharves 1 and 2 a Level I inspection was performed on all perimeter piles and all piles in every 5th bent. Also a Level II inspection was executed on approximately 5% of the piles.

The bulkhead along Parking Apron No. 4 was exposed at mean low water and was inspected in the dry. The associated seaplane ramps were also exposed at mean low water although thickness measurements were taken on the steel H-piles under water.

In all levels of inspection of concrete piles, the concrete was regularly hit with a hammer to gauge the soundness of the concrete and to detect any softness that might be present.

It should be noted that non-destructive methods of inspection were employed. The conditions noted reflect direct observation

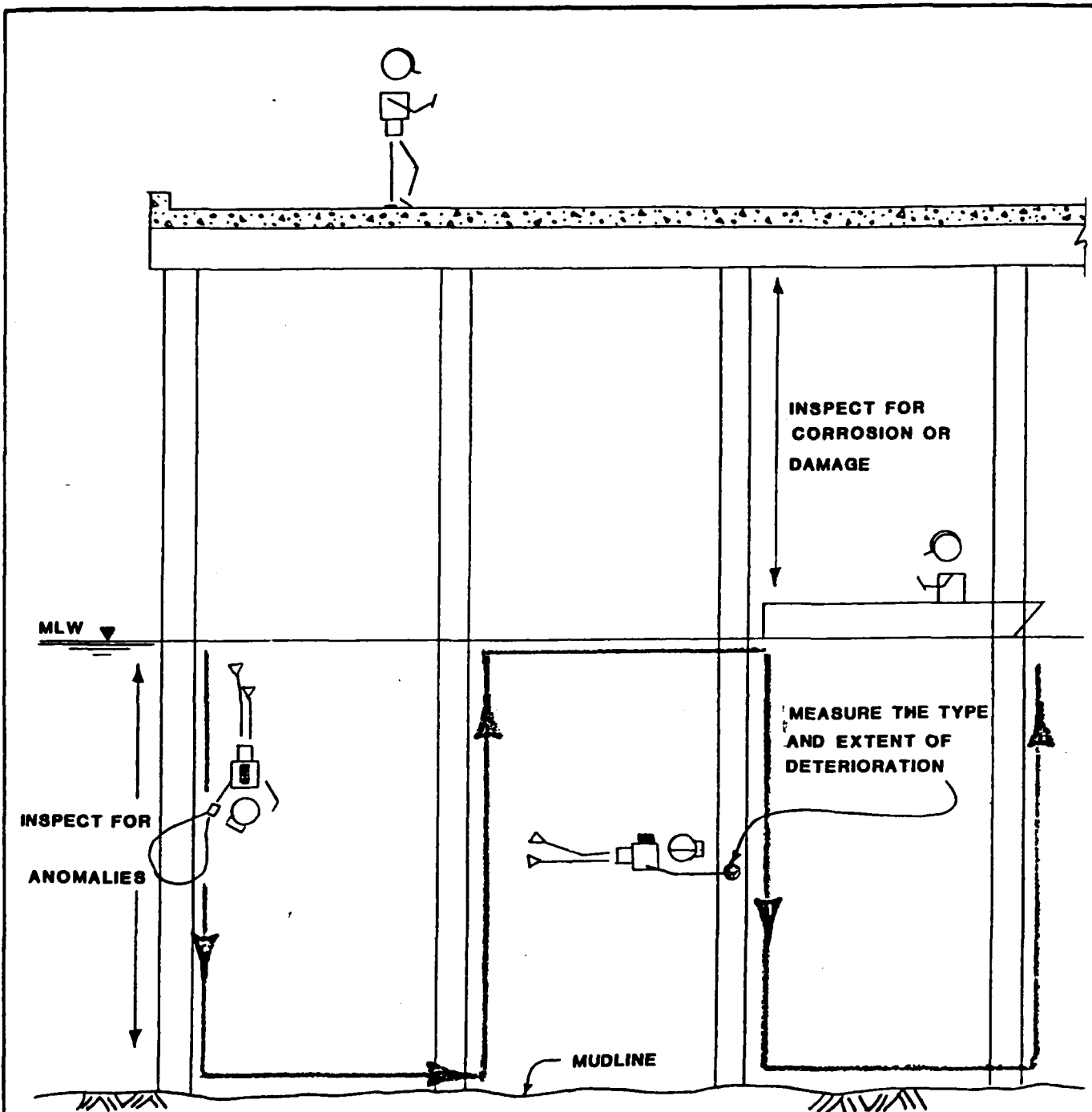

**TYPICAL DIVER INSPECTION PATH  
LEVEL I**

GRAPHIC SCALE	CHLDS ENGINEERING CORPORATION BOX 333 MEDFIELD, MA	CHESAPEAKE DIVISION NAVAL FACILITIES ENGINEERING COMMAND WASHINGTON, D.C.	
NA		NAVAL AIR STATION ALAMEDA, CA <b>INSPECTION PATH</b>	FIG. NO. <b>3</b>

of structural components. Information which may infer knowledge of conditions not accessible by non-destructive testing methods is based on government-furnished documents, our knowledge of structures in similar environments and/or generally accepted engineering theories.

### 3.3 INSPECTION EQUIPMENT

Equipment used for inspection included a Krautkramer D-Meter ultrasonic steel thickness gauge with DMR Probe and a Nikon III with 28mm lens, an Ikelight 150L Superstrobe, dive lights, 100-foot cloth tape, 6' rule, chipping hammers and dive knives.

Choice of equipment was made as a result of past experience. Most of the equipment is straightforward, easy to handle, carry and use, and has proven reliable under hard use.

Ultrasonic steel thickness gauging is preferred over other techniques (such as drilling test holes) since it is non-destructive, easy to handle, fast and reasonably accurate.

Within this section of the report, each facility inspected at the Naval Air Station is referenced separately. The discussion of each facility is presented in four parts: 1) a description of the construction and function of the structure, which is derived from both the on-site inspection and from the referenced government-furnished drawings; 2) an enumeration of general and specific conditions observed during the on-site inspection; 3) a qualitative assessment of the structural condition of the facility based on the inspection data; and 4) recommendations for actions to be taken to insure long-term, cost-effective maintenance and utilization of the facility. Detailed breakdowns of cost estimates are included in the Appendix.

Marine growth profiles were noted at each facility. These profiles were similar for all the facilities at the Naval Air Station. In general, mussels and barnacles, along with a covering of soft growth, including algae, sponges and various marine invertebrates, covered the concrete piles. This growth extended from mean tide level to within 1' to 2' of the mudline. The thinning out of growth at the mudline is probably due to either scouring or a change in the level of the mudline attributed to dredging. Mussels in some areas were as thick as 4", but generally were scattered thinly along with barnacles. The soft growth was usually about 1" thick and could be found throughout each facility in combination with the mussels and barnacles.

On the concrete piles, deterioration was noted with respect to its structural significance. Piles not capable of supporting the imposed load were noted as severely damaged. This anomaly displayed the following characteristic:

- o Piles cracked and broken with rebar still intact  
(see Figure 4).

A condition where the concrete has spalled to a point where the cross sectional area of the remaining pile has marginal capabilities to support its designed load is noted as heavy spalling (see Figure 5). In many cases of heavy spalling, rebar is exposed to the water and has experienced corrosion.

Spalling that does not immediately threaten the structural integrity of the pile was noted as light (see Figure 5).

Hereafter in this report, there will be reference to these common conditions.

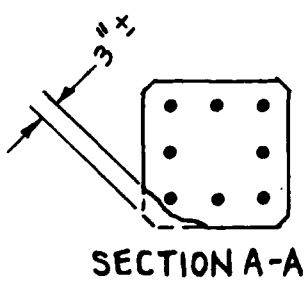
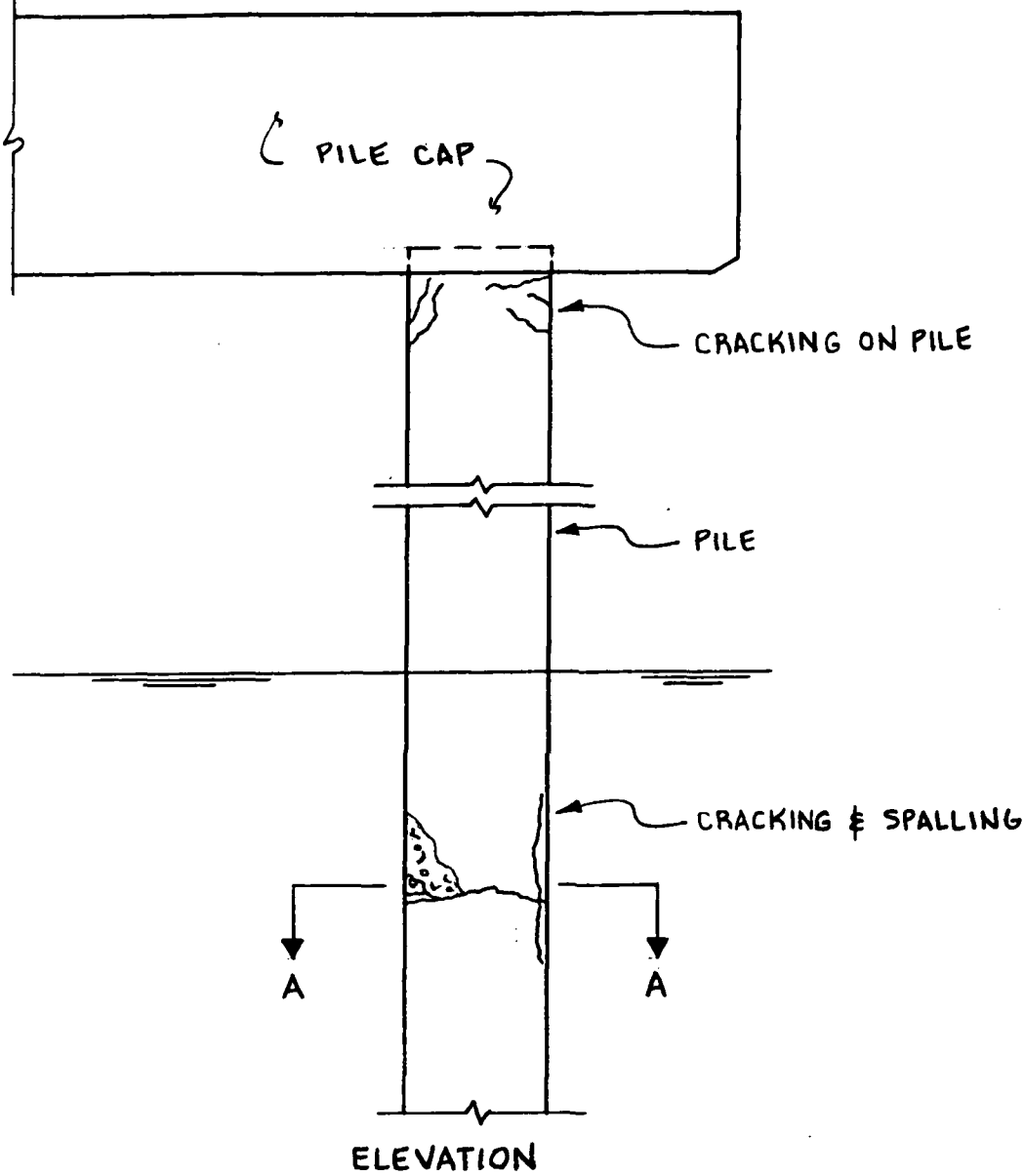

SEVERE DAMAGE

GRAPHIC SCALE	CHILDS ENGINEERING CORPORATION BOX 333 MEDFIELD, MA	CHESAPEAKE DIVISION NAVAL FACILITIES ENGINEERING COMMAND WASHINGTON, D.C.	
NA		NAVAL AIR STATION ALAMEDA, CA <b>PILE CONDITION</b>	FIG. NO. <b>4</b>

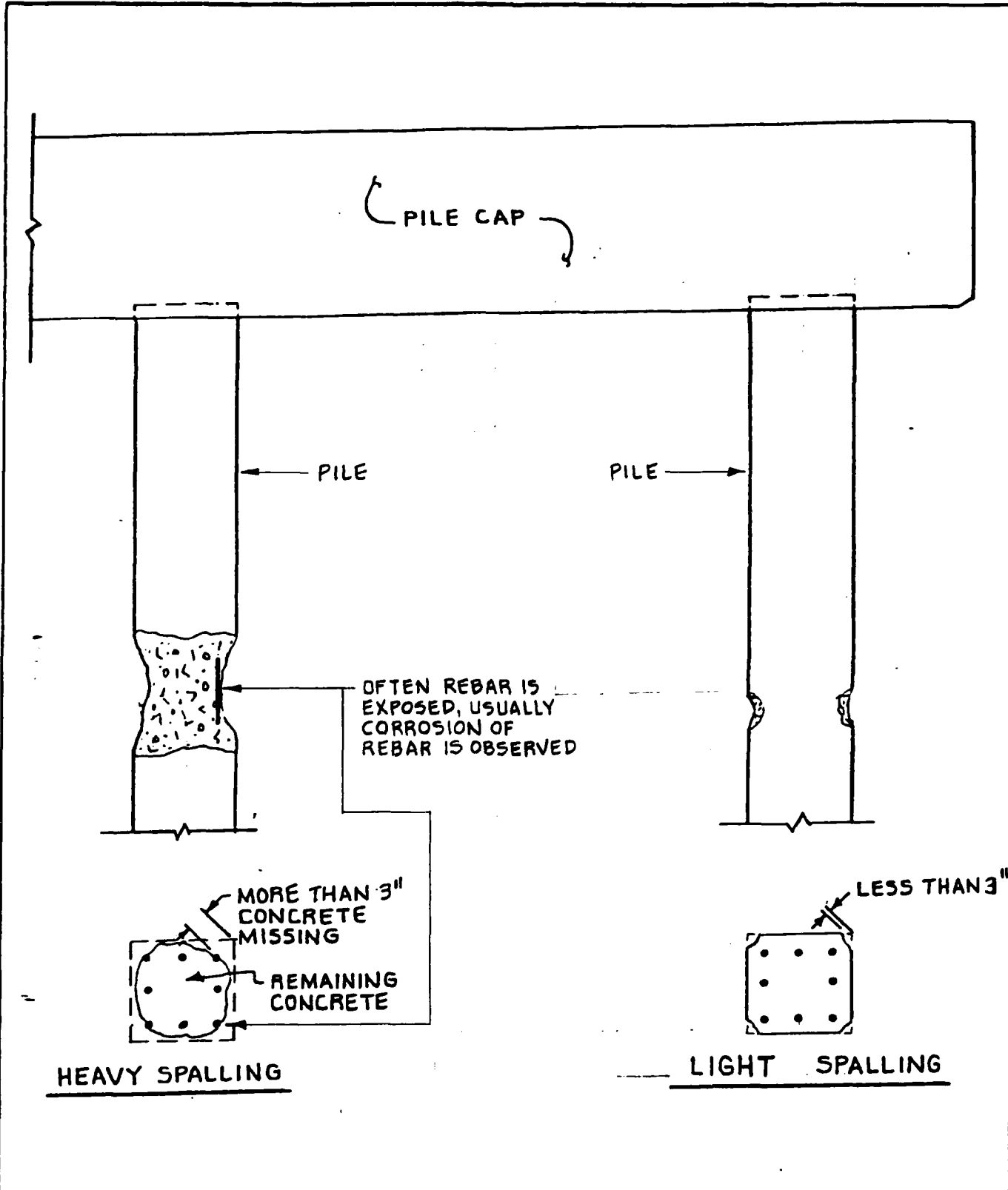

GRAPHIC SCALE	CHILDS ENGINEERING CORPORATION BOX 223 MEDFIELD, MA	CHESAPEAKE DIVISION NAVAL FACILITIES ENGINEERING COMMAND WASHINGTON, D.C.	
		NAVAL AIR STATION ALAMEDA, CA	FIG. NO. 5
NA		PILE CONDITION	



PHOTO #8: Pile A Bent 131, Elevation 96.0.  
Spalled concrete at pile corner.  
Vertical and horizontal cracks.  
Pile severely damaged.

PHOTO #9: Pile A Bent 130, Elevation 96.0.  
Vertical and horizontal cracks.  
Pile severely damaged.



## 4.1 CARRIER PIER - PIER 3

### 4.1.1 DESCRIPTION

Pier 3 was built in 1945 and is 1355' long by 150' wide. Its reinforced concrete deck is supported by approximately 4,440 20" square precast concrete piles, of which approximately 3,900 are vertical piles and 540 are batter piles (see Figures 6 through 10). The vertical piles are jacketed in concrete from the pile cap down 13'0". The jackets provide a 4" concrete cover on all pile faces. The driven capacity of each pile is 45 tons. The design live load on the deck is 500 psf.

It is the southernmost facility in this activity and is adjacent to Wharf 2 (see Figure 2). Pier 2, just to the north, runs parallel to Pier 3.

Pier 3 is the largest berthing facility at NAS Alameda and can simultaneously accommodate two nuclear-powered attack carriers. Total feet of berth available at this pier is 2,500.

Reference: Navy Department Bureau of Yards and Docks  
Y & D Drawings Nos. 317483, 317484 and 317497

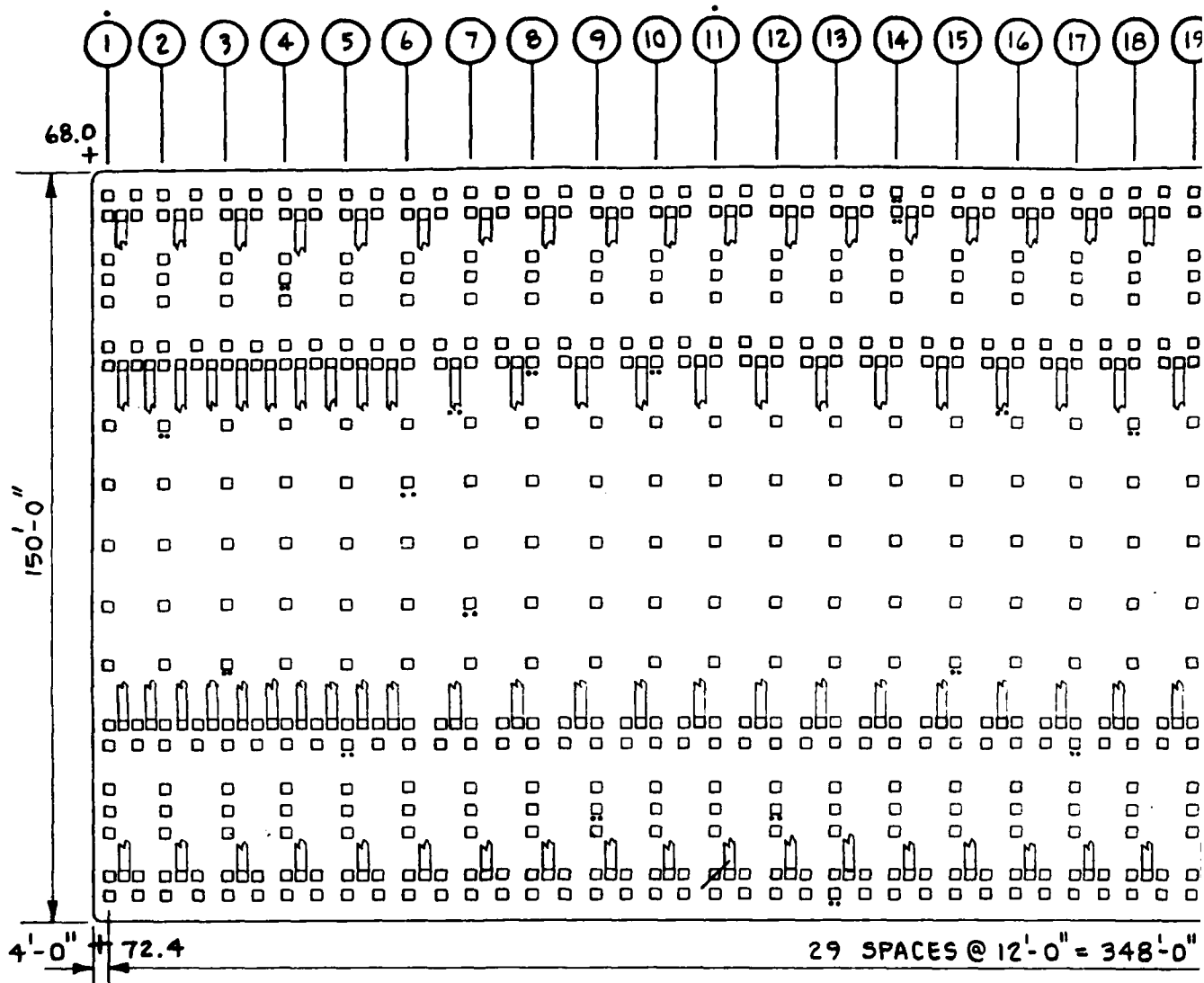

LEVELS OF INSPECTION

ⓑ OR Ⓐ LEVEL I (ALL PILES IN BENT OR ROW)  
 ☐ LEVEL II

PLAN  
 SCALE AS SHOWN

LEGEND

⊙ SEVERE DAMAGE (REQUIRES REPLACEMENT)  
 ✕ HEAVY SPALLING  
 ▧ LIGHT SPALLING

65.0 ELEVATION (MLLW EL 100.0')

NOTE:  
 REFERENCE TAKEN FROM  
 Y&D DWG NOS. 317483 & 317484.

16 17 18 19 20 21 22 23 24 25 26 27 28 29 30

12'  
(TYP)

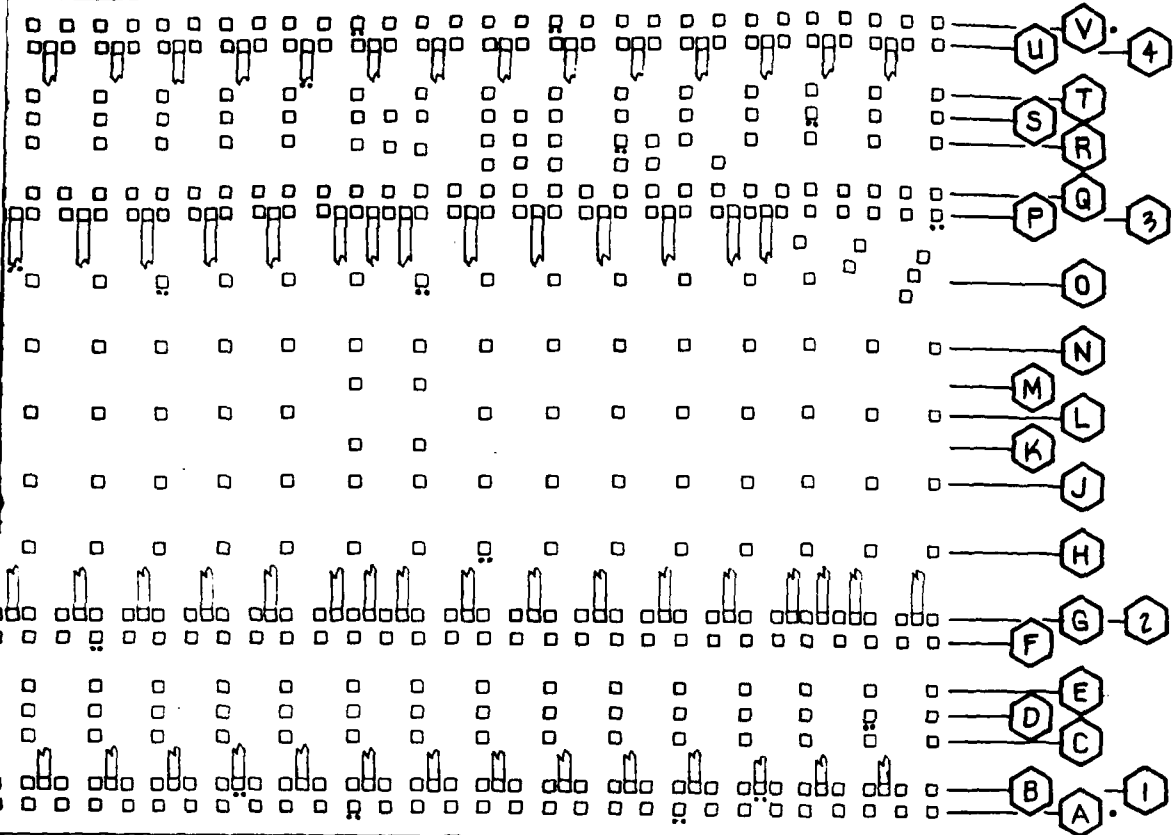

12'-0" = 348'-0"

MATCH LINE A (BENT 30)

N  
S SHOWN

2

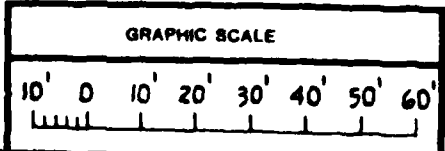

CMLDS ENGINEERING CORPORATION  
BOX 933  
MEDFIELD, MA

CHESAPEAKE DIVISION  
NAVAL FACILITIES ENGINEERING COMMAND  
WASHINGTON, D.C.

NAVAL AIR STATION ALAMEDA, CA

**PIER #3**

FIG. NO.  
**6**

FROM  
483 # 317484.

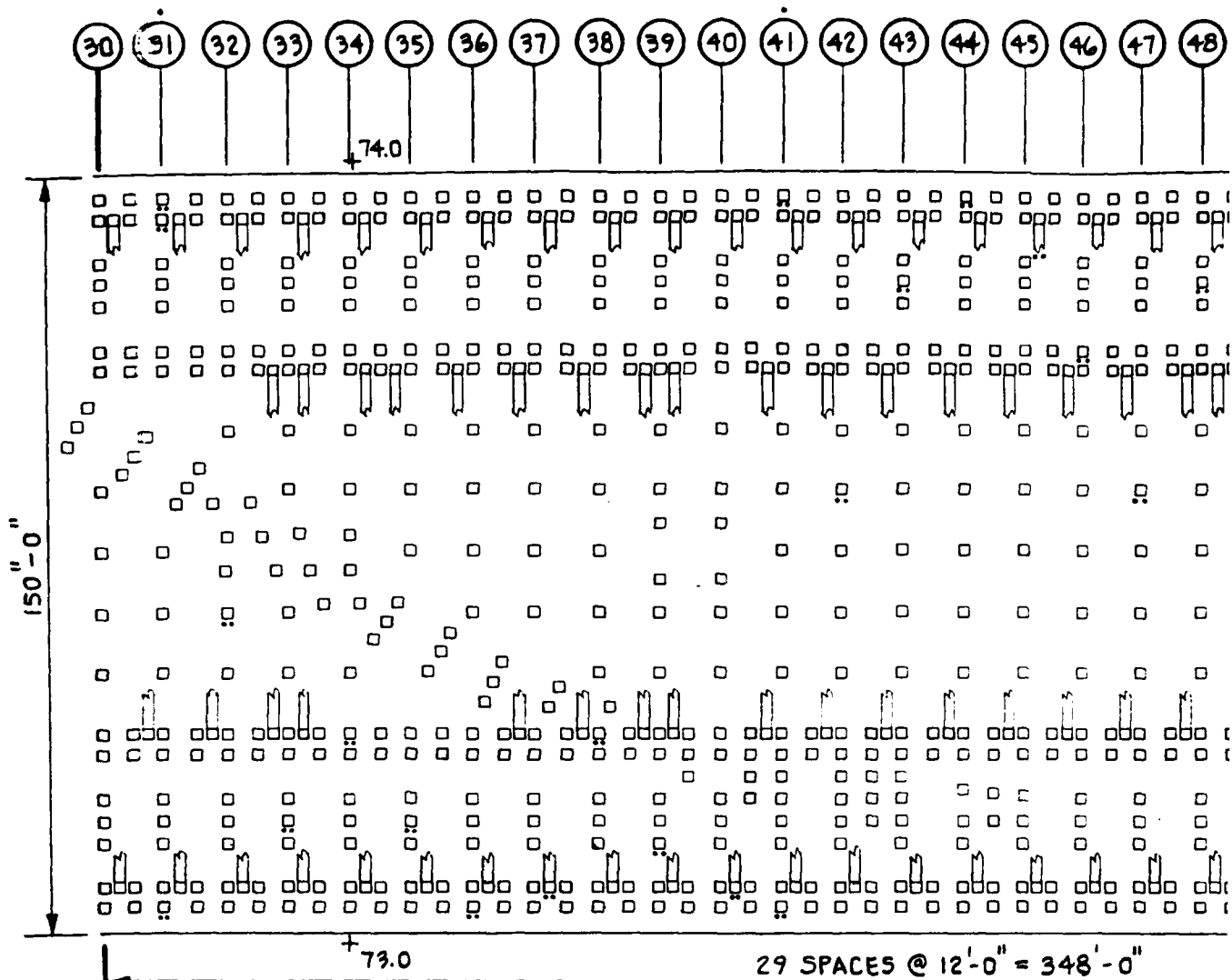

**LEVELS OF INSPECTION**

⊙ OR ⊕ LEVEL I (ALL PILES IN BENT OR ROW)  
 □ LEVEL II

**PLAN**  
 SCALE AS SHOWN

**LEGEND**

⊙ SEVERE DAMAGE (REQUIRES REPLACEMENT)  
 ✕ HEAVY SPALLING  
 ▧ LIGHT SPALLING  
 65.0 ELEVATION (MLLW EL 100.0')

**NOTE:**  
 REFERENCE TAKEN FROM Y&D  
 DWG NOS. 317483 & 317484.

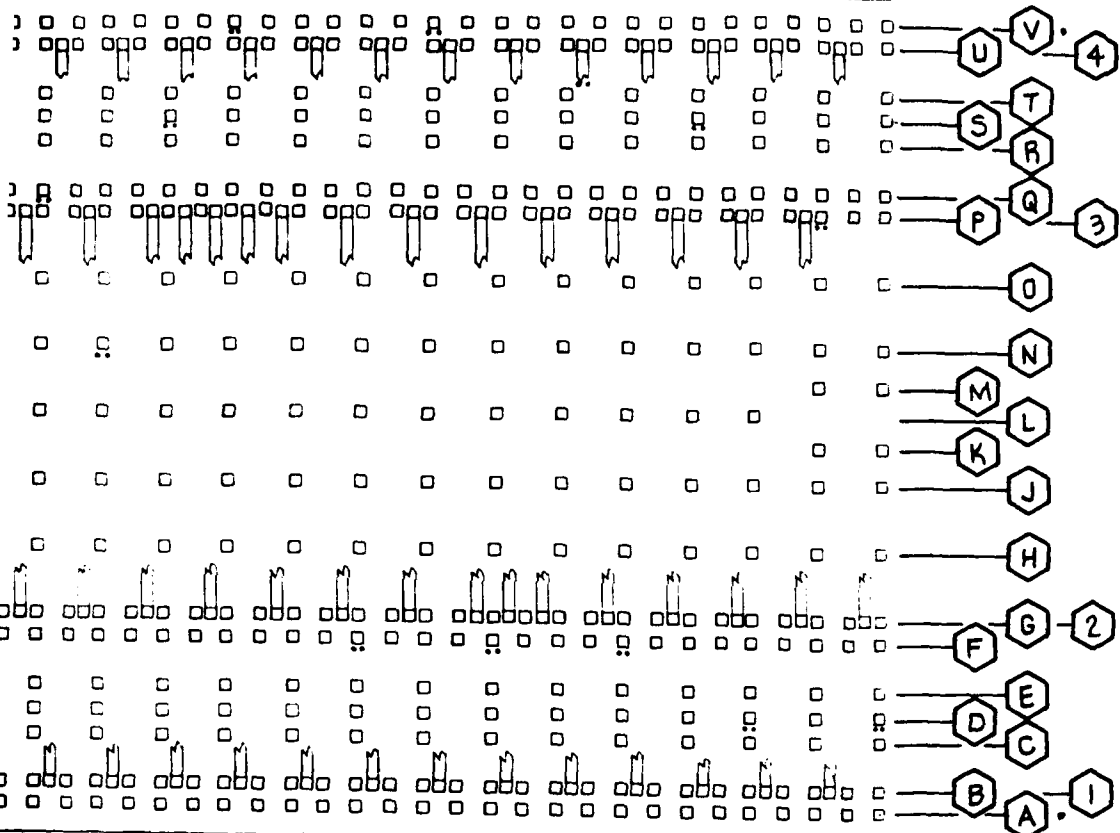
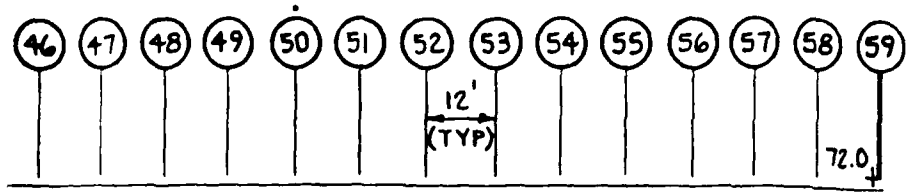

348'-0" 70.0'

MATCH LINE B (BENT 59)

2

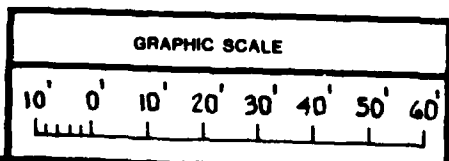

CHLDS ENGINEERING CORPORATION  
BOX 333  
WENFIELD, MA

CHESAPEAKE DIVISION  
NAVAL FACILITIES ENGINEERING COMMAND  
WASHINGTON, D.C.  
NAVAL AIR STATION ALAMEDA, CA  
**PIER #3**

FIG. NO.  
**7**

EN FROM Y&D  
3 & 317484.

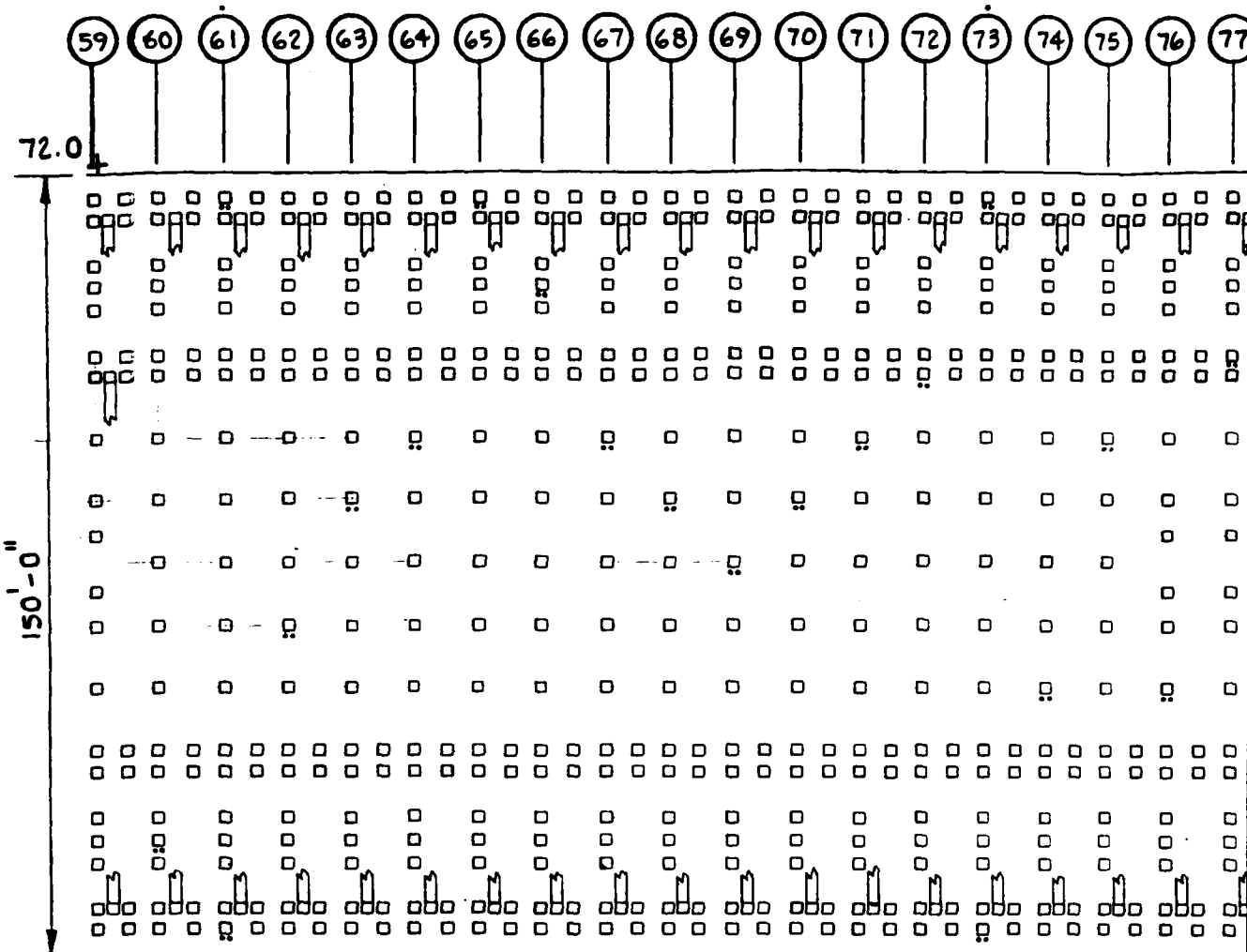

MATCH LINE B (BENT 59)

**LEVELS OF INSPECTION**

- ⊙ OR ⊕ LEVEL I (ALL PILES IN BENT OR ROW)
- ⊠ LEVEL II

PLAN  
SCALE AS SHOWN

**LEGEND**

- ⊙ SEVERE DAMAGE (REQUIRES REPLACEMENT)
- ⊗ HEAVY SPALLING
- ⊘ LIGHT SPALLING

65.0 ELEVATION (MLLW EL 100.0')

**NOTE:**  
REFERENCE TAKEN FROM Y&D  
DWG NOS. 317483 & 317484.

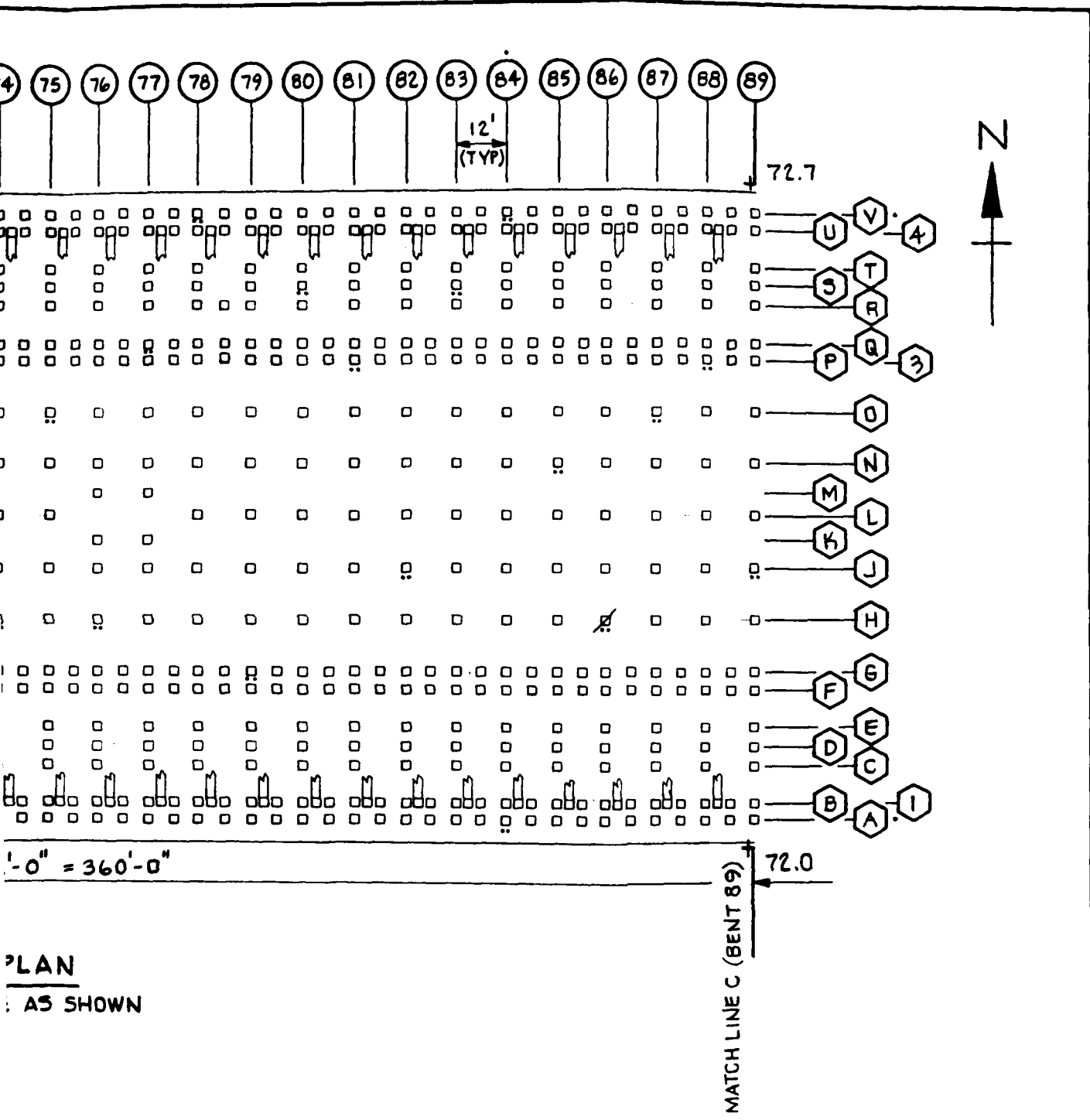

2

<p>GRAPHIC SCALE</p> <p>10' 0 10' 20' 30' 40' 50' 60'</p>	<p>CHILDS ENGINEERING CORPORATION BOX 333 MEDFIELD, MA</p>	<p>CHESAPEAKE DIVISION NAVAL FACILITIES ENGINEERING COMMAND WASHINGTON, D.C.</p>	
		<p>NAVAL AIR STATION ALAMEDA, CA</p>	<p>FIG. NO. 8</p>

EN FROM Y&D  
3 # 317484.

MATCH LINE C (BENT 89)

72.7

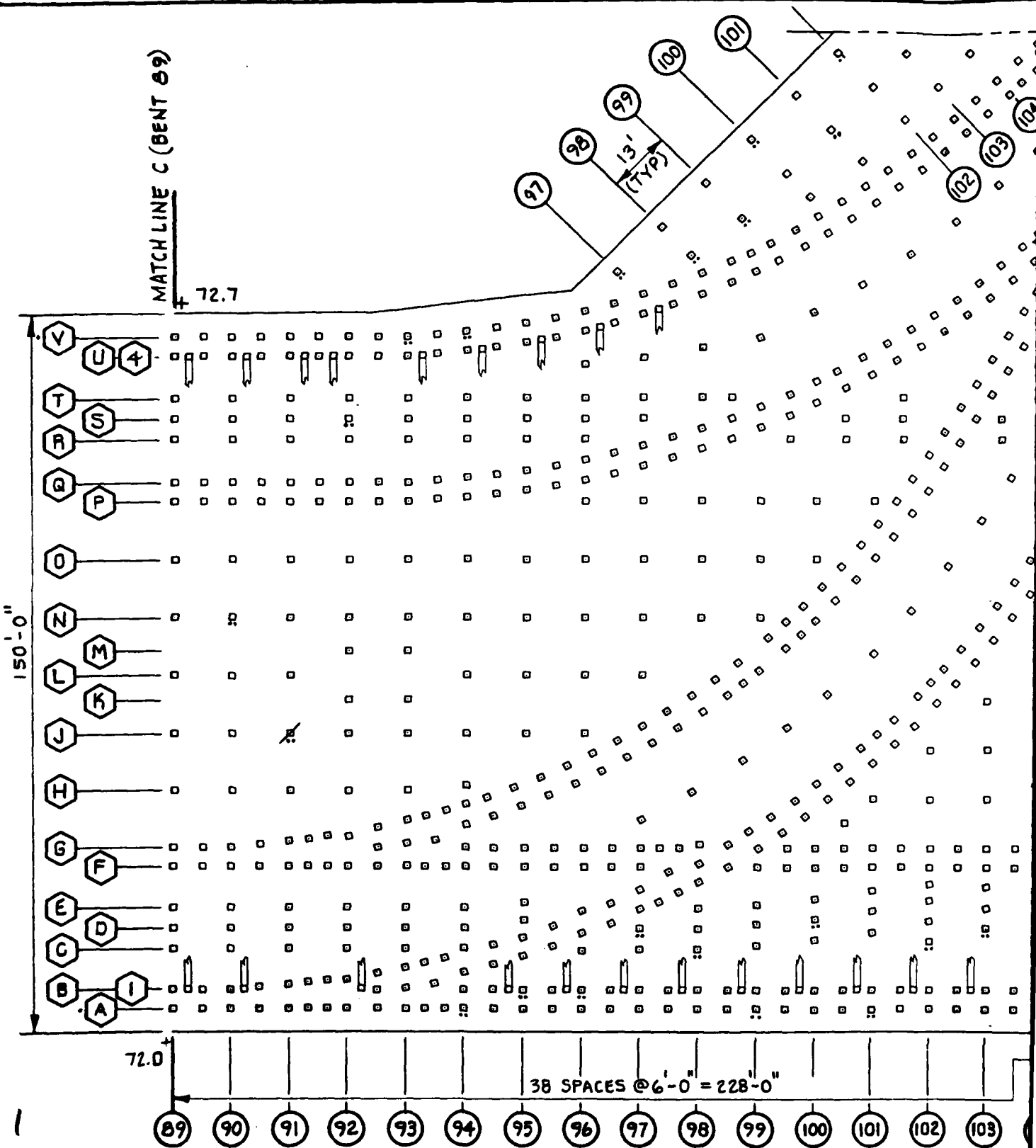

**NOTE:**

REFERENCE TAKEN FROM Y&D  
DWG NOS. 317483 & 317484.

**PLAN**

SCALE AS SHOWN

MATCH LINE - D

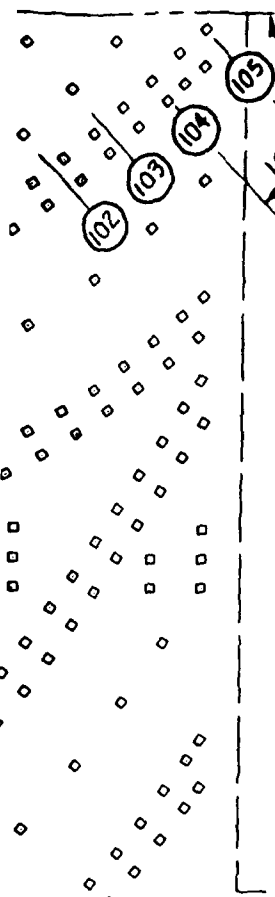

### LEVELS OF INSPECTION

- ⊙ OR ⬡ LEVEL I (ALL PILES IN BENT OR ROW)
- ⊠ LEVEL II



### LEGEND

- ⊙ SEVERE DAMAGE (REQUIRES REPLACEMENT)
  - ⊠ HEAVY SPALLING
  - ⊠ LIGHT SPALLING
- 65.0 ELEVATION (MLLW EL 100.0')

FACE OF SEAWALL

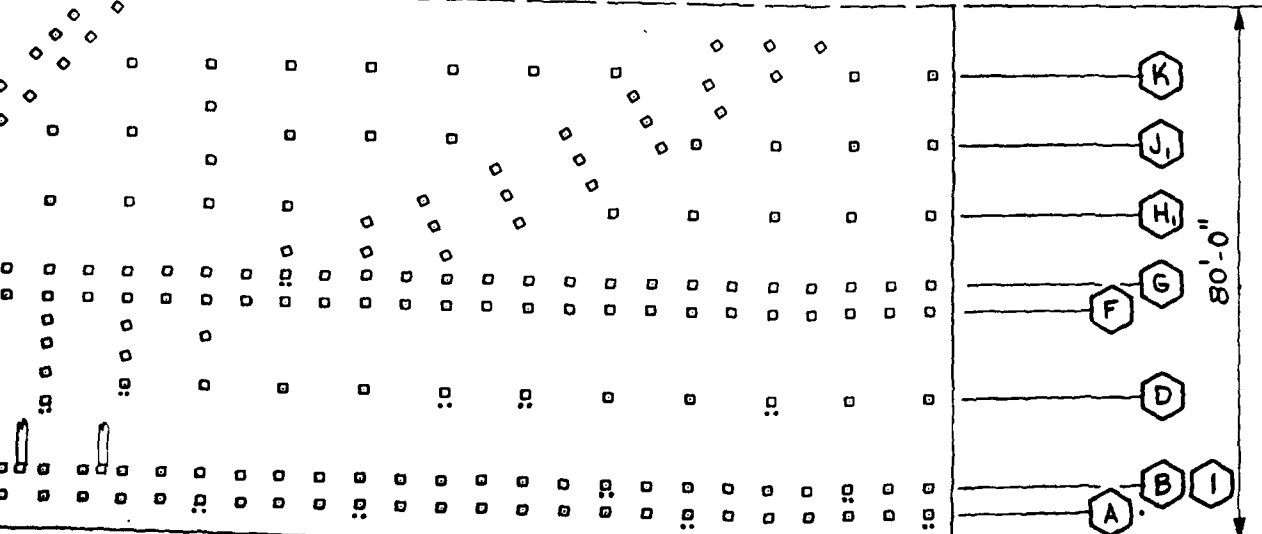

K  
J  
H  
G  
F  
D  
A B I

80'-0"

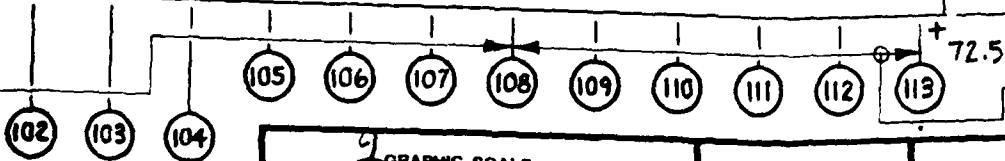

72.5'  
10 SPACES @ 6'-2" = 61'-8"

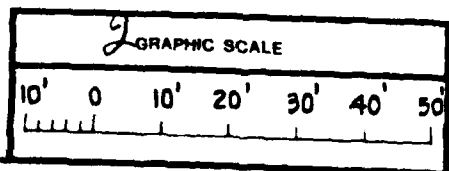

CHILDS ENGINEERING CORPORATION  
 BOX 333  
 MEDFIELD, MA

CHESAPEAKE DIVISION NAVAL FACILITIES ENGINEERING COMMAND WASHINGTON, D.C.	
NAVAL AIR STATION	ALAMEDA, CA
<b>PIER #3</b>	<b>FIG. NO. 9</b>

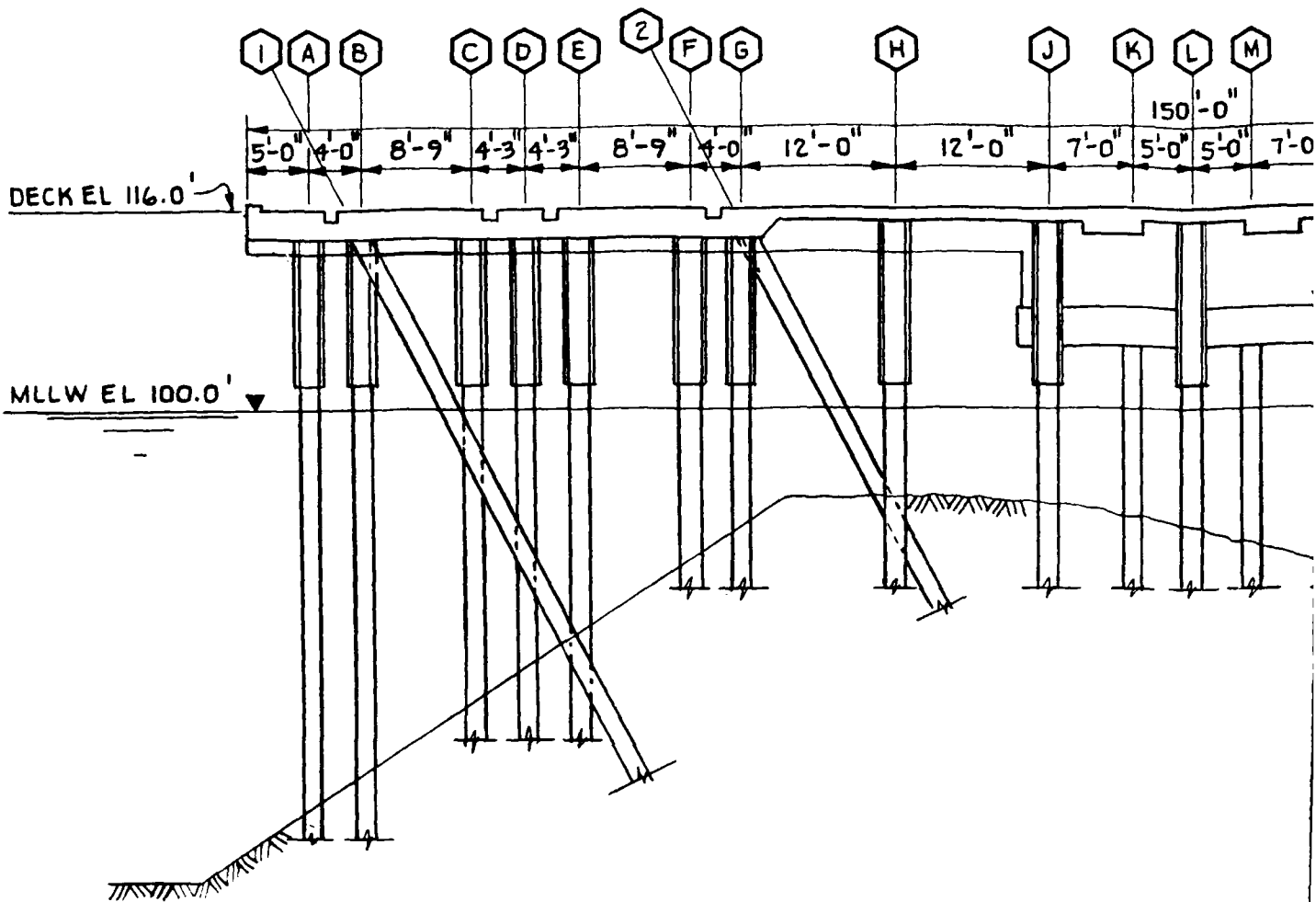

DECK EL 116.0'

MLLW EL 100.0'

TYPICAL CROSS SECTION  
SCALE AS SHOWN

NOTE:  
REFERENCE TAKEN FROM  
Y&D DWG NO. 317497.

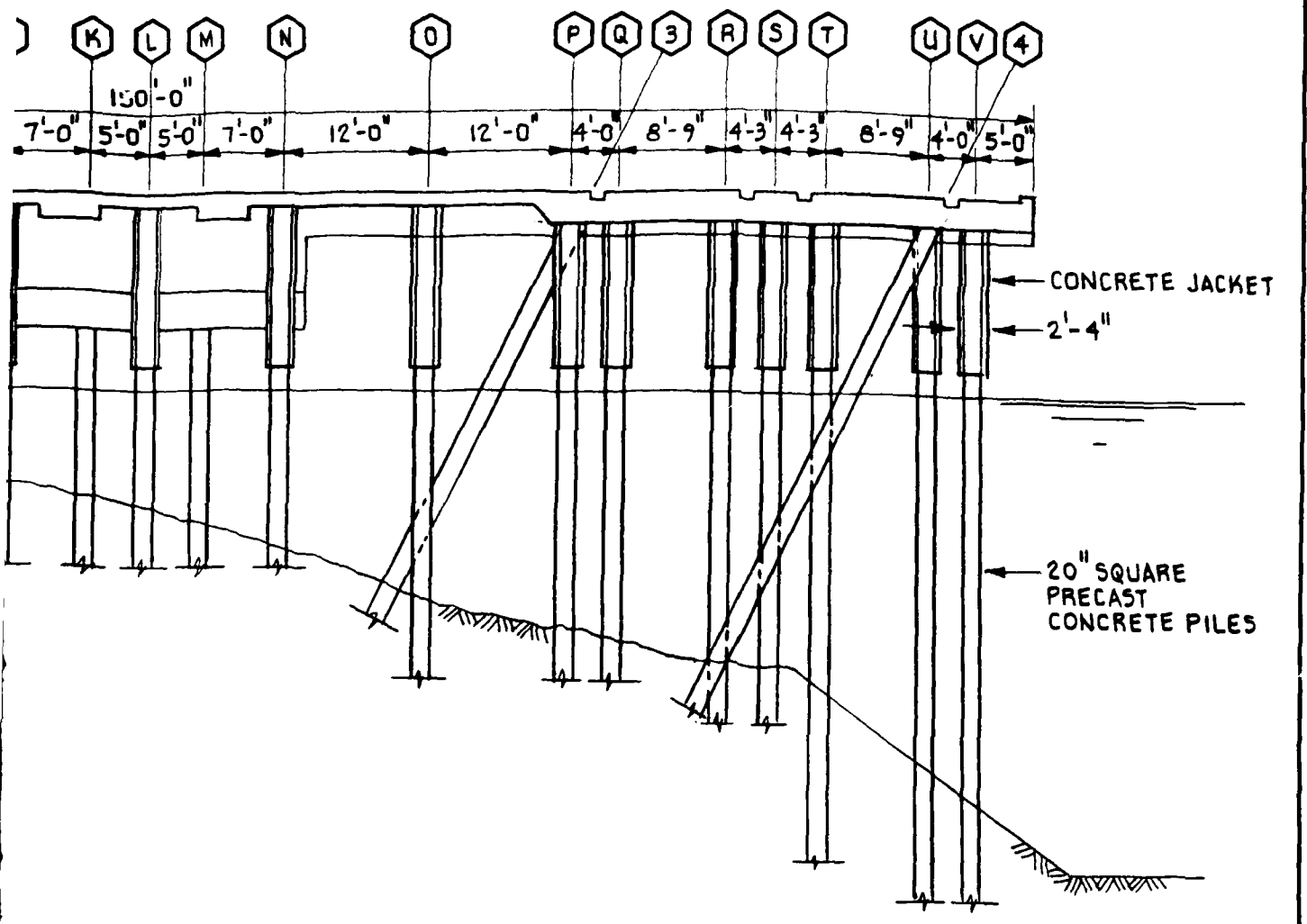

ICAL CROSS SECTION  
SCALE AS SHOWN

<p>GRAPHIC SCALE</p>	<p>CHLDS ENGINEERING CORPORATION BOX 333 MEDFIELD, MA</p>	<p>CHESAPEAKE DIVISION NAVAL FACILITIES ENGINEERING COMMAND WASHINGTON, D.C. NAVAL AIR STATION ALAMEDA, CA PIER #3</p>	<p>FIG NO 10</p>
<p>5' 0 5' 10' 15' 20'</p>			

#### 4.1.2 OBSERVED INSPECTION CONDITIONS

In general, all of the piles which were inspected are in good to excellent condition. Although the pier is almost 40 years old, there has been very little deterioration of the concrete. Little or no softness in the concrete was observed, indicating that the original concrete mix was well-proportioned and resulted in a dense, impenetrable product.

1% of the piles inspected had some minor spalling or cracking. The observed deterioration is cosmetic in nature and is of no real structural significance.

There is no apparent pattern to the location on the pile or piles within the pier which have experienced the spalling and/or cracking.

All of the vertical piles in the pier are protected with concrete jackets from the pile cap to approximately Elevation 102.2 (see Photo #3). The jackets were installed when the piles were driven. The jackets are in excellent condition and have protected the piles from deterioration in the tidal zone. No softness in the concrete jackets was noted.

A few of the piles have been repaired in the area below the concrete jackets. The repairs consist of a steel form which has been filled with concrete and encases the pile. No information was found detailing the time that these repairs were made. Based on the location of the repaired piles (generally interior piles), it may be that the repairs were made at the time of original construction. It is possible that the piles were damaged during installation and rather than removing and driving new piles, the piles were repaired.



PHOTO #3: Pile V, Bent 86, Elevation 102. Base of pile jacket. Note clear definition of pile chamfered edges illustrating sound concrete.

PHOTO #4: Pile A, Bent 103. Elevation 85±. Typical marine growth including mussels, sponges and hair-like algae.

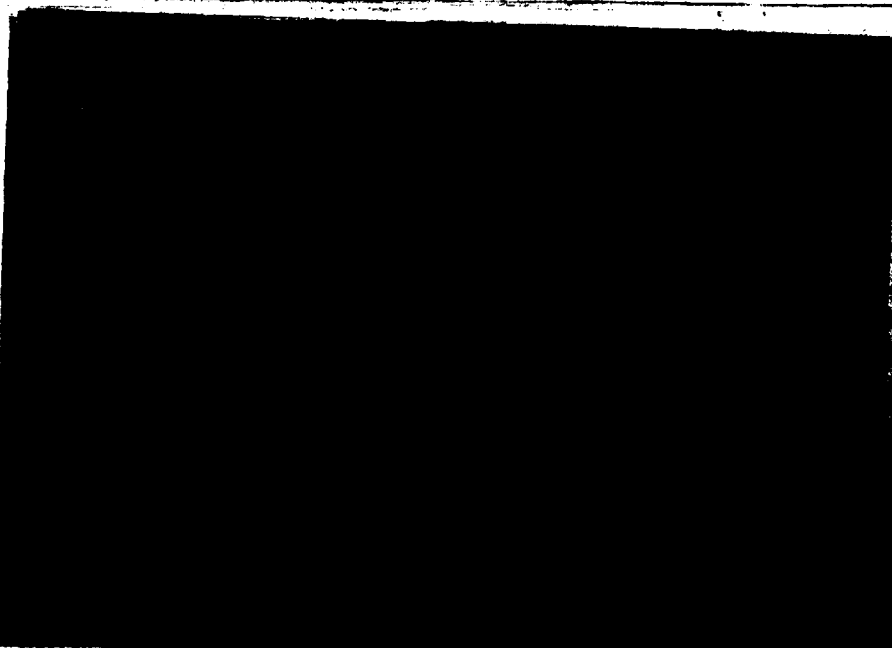

Typical of all facilities at NAS Alameda, the marine growth on the piles consisted of mussels, barnacles, sponges and hair-like algae (see Photo #4).

#### 4.1.3 STRUCTURAL CONDITION ASSESSMENT

Since no significant structural damage to any of the piles was observed, there is no significant loss in pile load carrying capacity and therefore no loss in overall pier capacity.

Calculations of original pile capacities indicate that all piles have sufficient strength to support current use loading.

#### 4.1.4 RECOMMENDATIONS

No repairs are recommended at this time.

The piles should be re-inspected in 5 years and this inspection should be used as a baseline to determine what, if any, deterioration has occurred.

## 4.2 WHARF NO. 2

### 4.2.1 DESCRIPTION

Wharf No. 2 is located in the southern portion of NAS Alameda, (see Figure 2). It is bordered to the north by Pier 2 and to the south by Pier 3. The wharf is functioning as an approach to Pier 3. Its reinforced concrete deck is supported by approximately 210 - 20" square concrete piles (see Figure 11). These piles have been jacketed in concrete from the pile cap down 13'. The jackets provide a 4" concrete cover on all pile faces. The wharf is 573' long and 45' wide. Design deck live load is 500 psf and the driven capacity of each pile is 45 tons.

Reference: Navy Department Bureau of Yards and Docks  
Y and D Drawing No. 317494

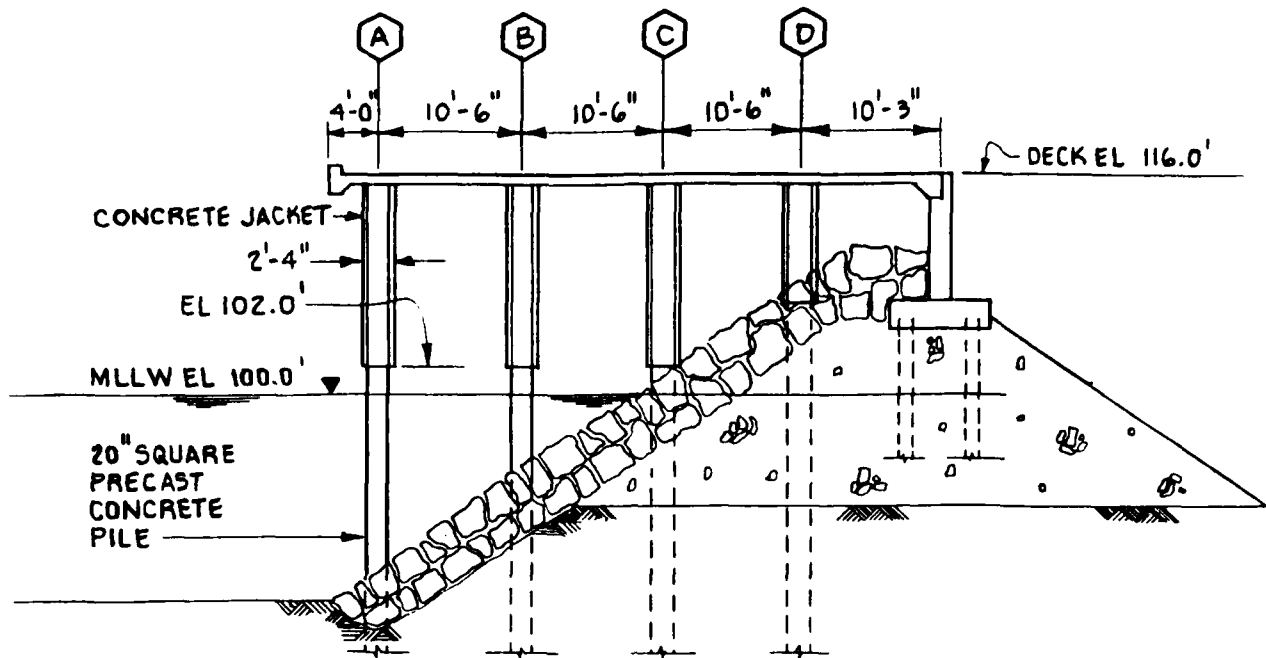

**TYPICAL CROSS SECTION**

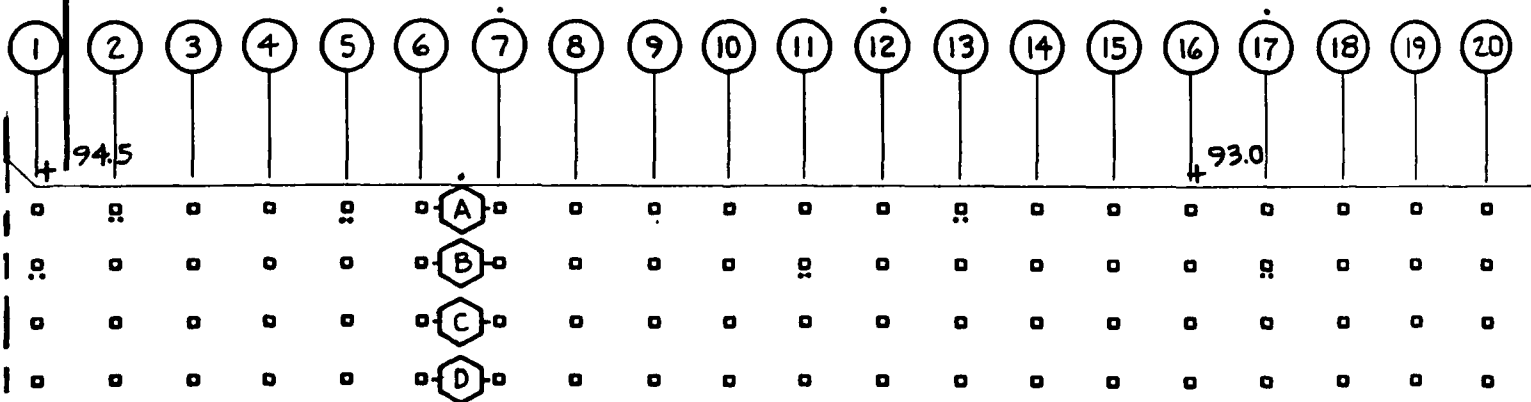
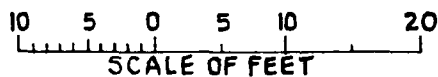

26 SPACES @ 14'-0" = 364'-0"

5'-10 1/2"

**PLAN**

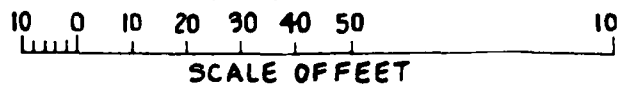

**NOTE:**  
REFERENCE TAKEN FROM  
Y&D NO. 317494.

MATCH LINE-D



**LEVELS OF INSPECTION**

- ⊙ OR ⊕ LEVEL I (ALL PILES IN BENT OR ROW)
- LEVEL II

**LEGEND**

- ⊙ SEVERE DAMAGE (REQUIRES REPLACEMENT)
- ⊗ HEAVY SPALLING
- ⊘ LIGHT SPALLING

65.0 ELEVATION (MLLW EL 100.0')

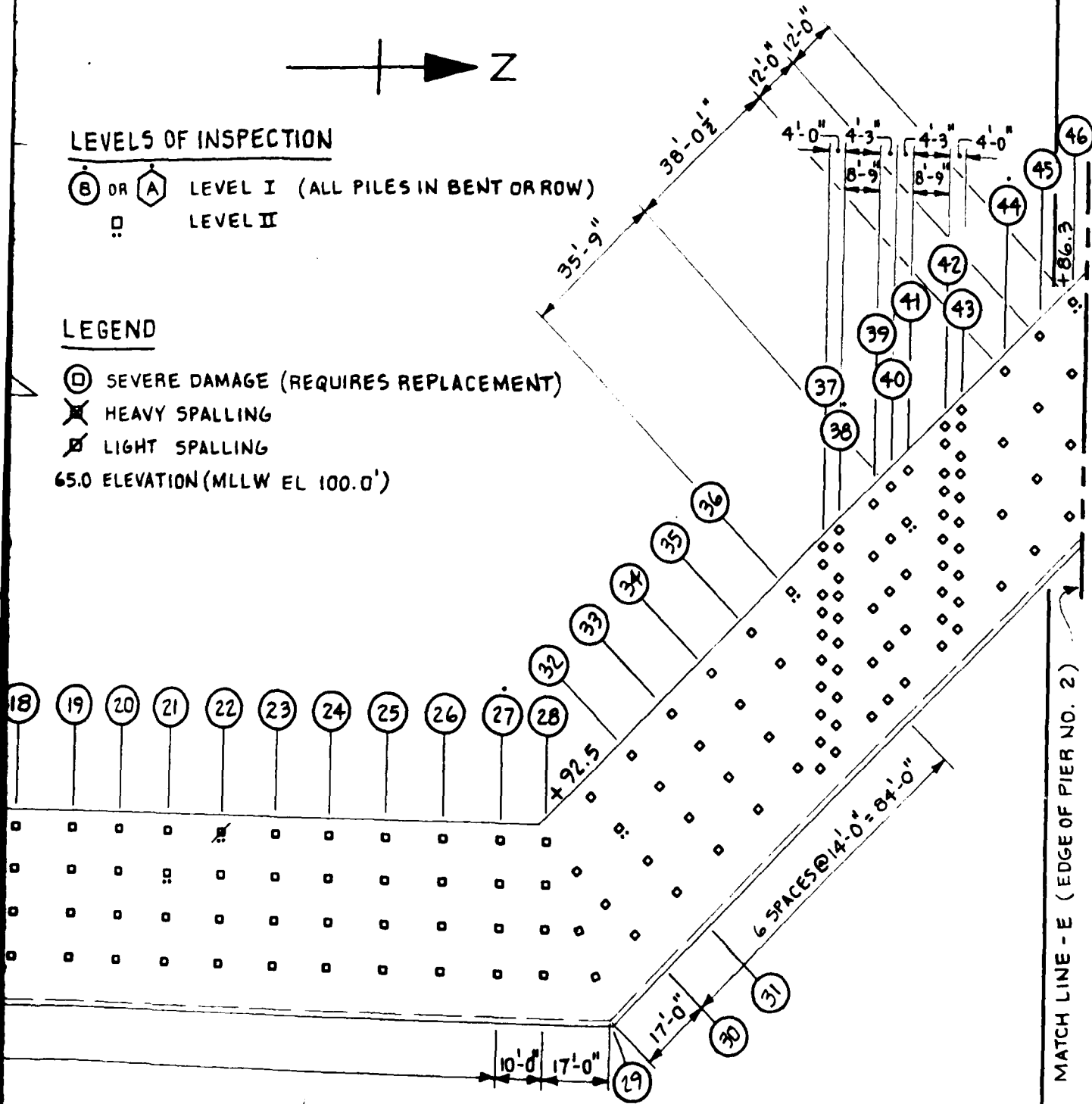

100

GRAPHIC SCALE	CHILDS ENGINEERING CORPORATION BOX 332 MEDFIELD, MA	CHESAPEAKE DIVISION NAVAL FACILITIES ENGINEERING COMMAND WASHINGTON, D C	
AS SHOWN		NAVAL AIR STATION <b>WHARF #2</b>	ALAMEDA, CA FIG NO <b>11</b>

#### 4.2.2 OBSERVED INSPECTION CONDITIONS

In general, all of the piles which were inspected are in good to excellent condition. Little or no softness in the concrete was observed, indicating that the original concrete mix was well-proportioned and resulted in a dense, impenetrable product.

One of the piles inspected had some minor spalling or cracking. The observed deterioration is cosmetic in nature and is of no real structural significance.

All of the piles in the wharf are protected with concrete jackets from the pile cap to approximately Elevation 102.0. The jackets were installed when the piles were driven. In general, the jackets are in excellent condition and have protected the piles from deterioration in the tidal zone.

One of the jackets is spalled at the base, Pile A Bent 25 (see Photo #5), exposing the pile. The pile is in good condition so the spall is of no structural significance.

Typical of all facilities at NAS Alameda, the marine growth on the piles consisted of mussels, barnacles, sponges and hair-like algae (see Photo #6).

Several piles have been repaired by replacement with new piles. The damaged piles are cracked and spalled, probably the result of driving since they're at interior locations. The replacement piles have been driven adjacent to the damaged piles.

Typical of all Level II inspections several of the piles were band cleaned at several locations along their length. Photo #7 illustrates a typical band cleaned location.



PHOTO #5: Pile A Bent 25, Elevation  
102.0. Spall at bottom of  
concrete jacket exposing  
pile.

PHOTO #6: Pile B Bent 15, Elevation  
102.0. Typical marine  
growth at base of pile  
jacket.

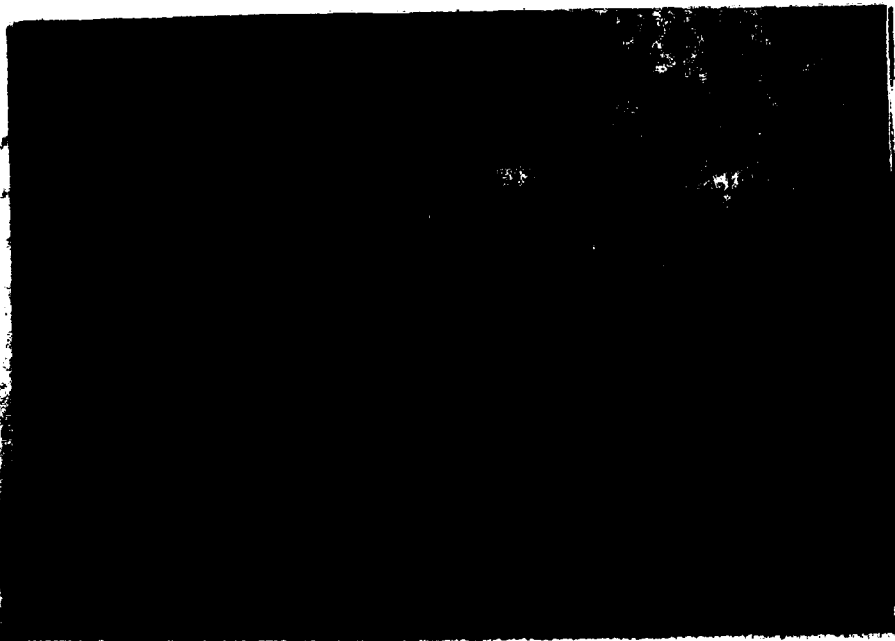

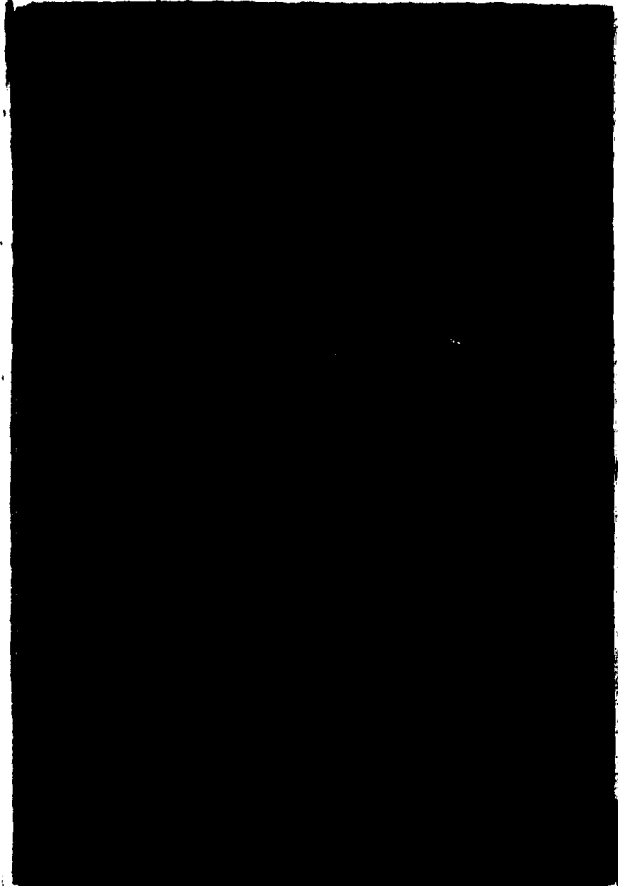

PHOTO #7:

Pile B, Bent 1, Elevation  
98.0. Typical band clean  
location for Level II  
inspection.

#### 4.2.3 STRUCTURAL CONDITION ASSESSMENT

Since no significant structural damage to any of the piles was observed, there is no significant loss in pile load carrying capacity and therefore no loss in overall pier capacity.

Calculations of original pile capacities indicate that all piles have sufficient strength to support current use loading.

#### 4.2.4 RECOMMENDATIONS

No repairs are recommended at this time.

The piles should be re-inspected in 5 years and this inspection should be used as a baseline to determine what, if any, deterioration has occurred.

### 4.3 PIER 2

#### 4.3.1 DESCRIPTION

The original pier was built in 1941 and is 1001' long by 80' wide. Its reinforced concrete deck is supported by approximately 1,006 structural piles. In 1974 the pier was extended 18 bents, 210'. The older portion of the pier has approximately 870 - 20" square precast piles, of which 714 are vertical piles and 166 are batter piles. The new section of the pier consists of approximately 136 18" square prestressed, precast structural piles; 102 vertical piles and 34 batter piles (see Figures 12 and 13). The driven capacity of each pile is 50 tons. The design live load on the deck is 400 psf.

Pier 2 is adjacent to Wharf 2 to the south and Wharf 1 to the north. It is also sandwiched between Pier 1 and Pier 3, (see Fig.2).

Pier 2 has four berthing spaces available totaling 2,420 feet. One of these spaces has been reserved for fleet operations and is left vacant. Transient vessels utilize this berth for loading and off-loading small amounts of ordnance. The remaining three berthing spaces usually accommodate AOE, AOR, and DD combinations of ships.

Reference: Navy Department Bureau of Yards and Docks  
Y & D Drawing No. 161, 013  
Department of the Navy Naval Facilities Engineering  
Command - NAVFAC Drawings Nos. 6018843, 6018845

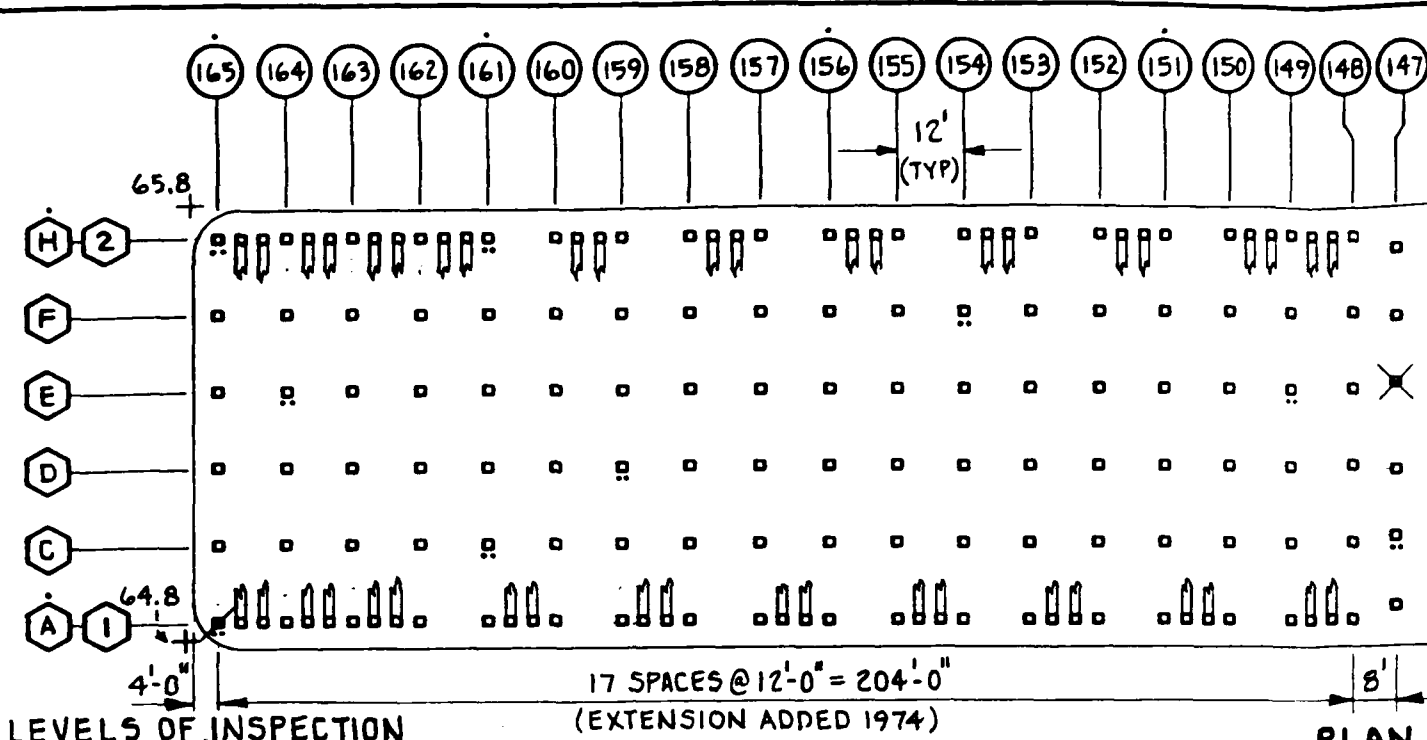

**LEVELS OF INSPECTION** **PLAN**  
 SCALE AS SHOWN

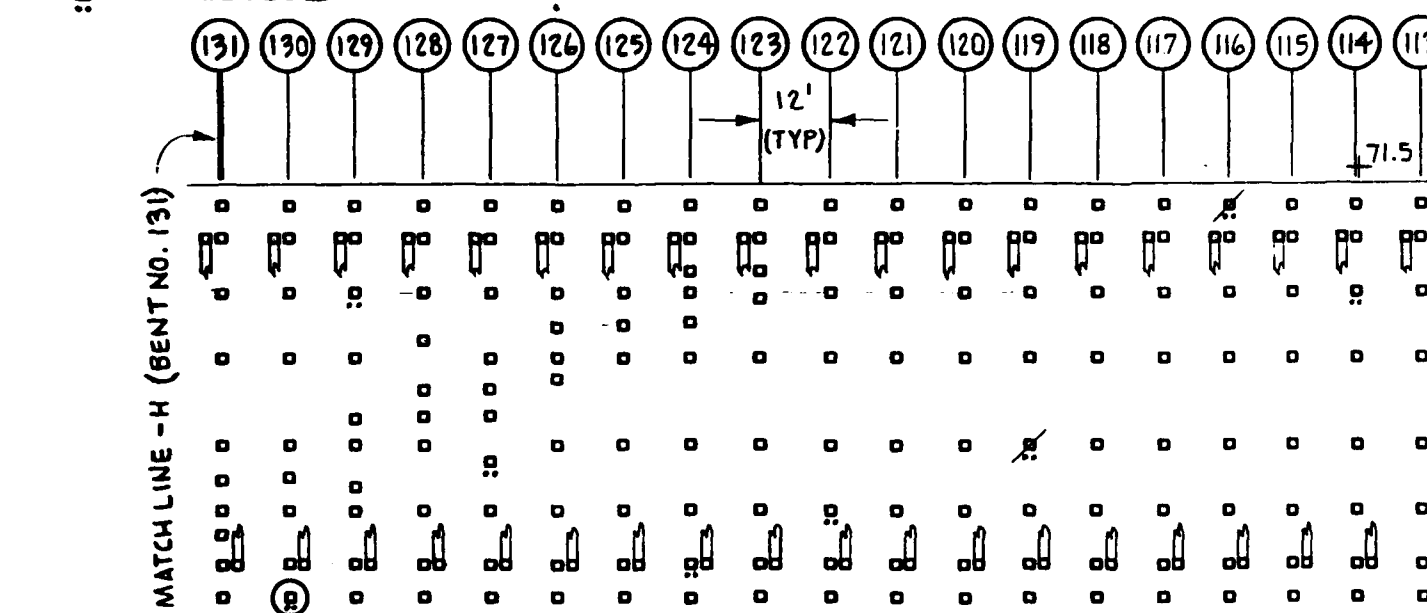

**LEGEND** + 70.0  
31 SPACES @ 12'-0" = 372'-0"

- ⊙ SEVERE DAMAGE (REQUIRES REPLACEMENT)
- ✕ HEAVY SPALLING
- ⊠ LIGHT SPALLING
- 65.0 ELEVATION (MLLW EL 100.0')

**NOTE:**  
 REFERENCE TAKEN FROM Y&D  
 DWG NO. 161,013 & NAVFAC  
 DWG NOS. 6018843 & 6018845.

**PLAN**  
 SCALE AS SHOWN

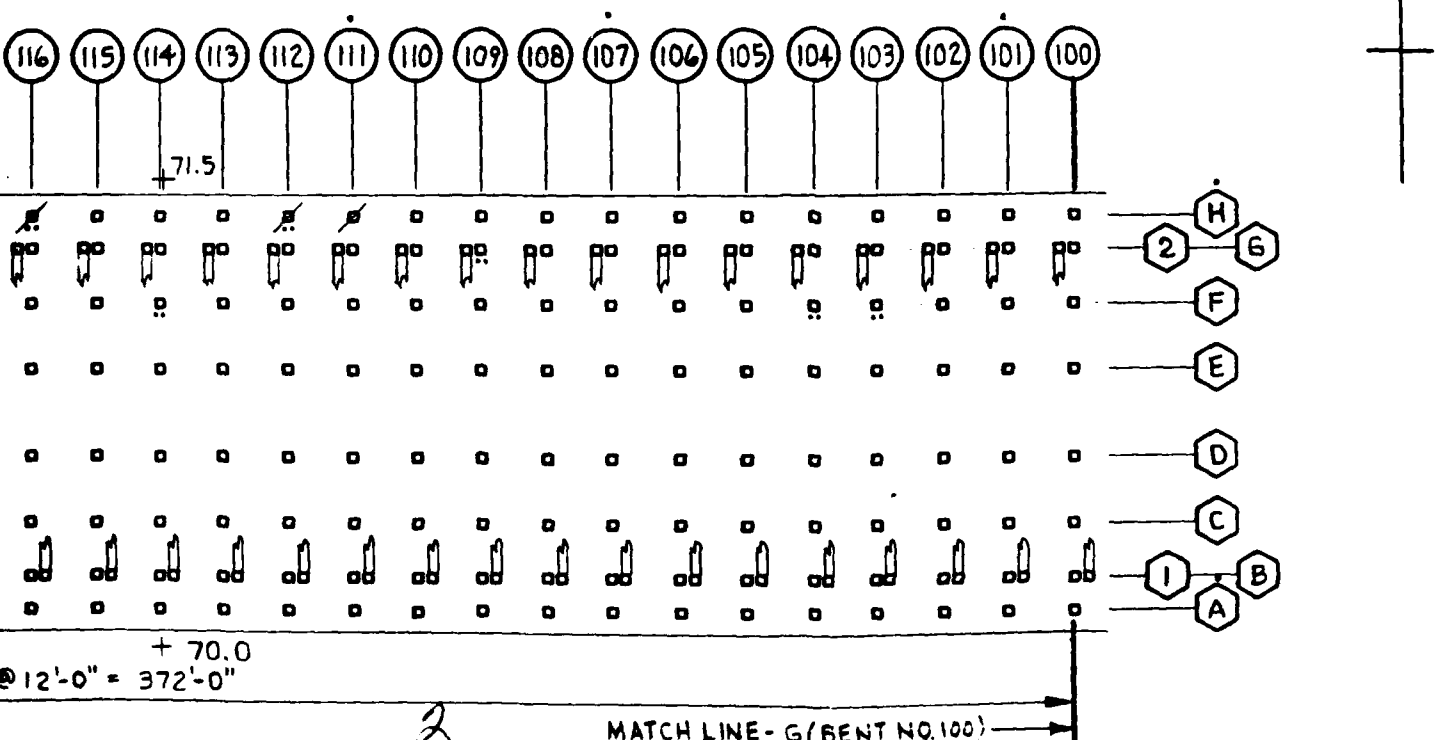
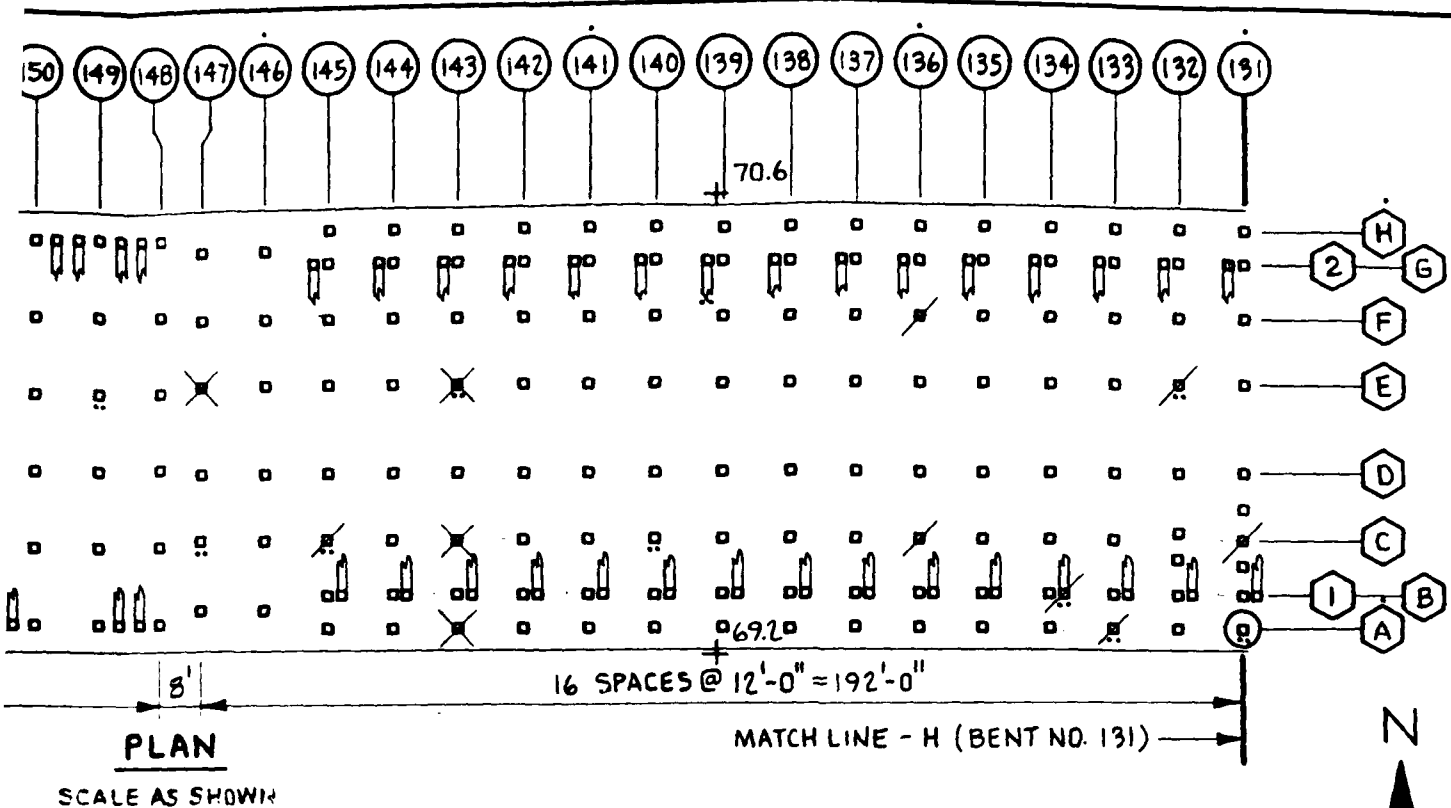

<p>GRAPHIC SCALE</p> <p>10' 0 10' 20' 30' 40' 50'</p>	<p>CHARLES ENGINEERING CORPORATION BOX 333 MEDFIELD, MA</p>	<p>CHESAPEAKE DIVISION NAVAL FACILITIES ENGINEERING COMMAND WASHINGTON, D.C.</p>	
		<p>NAVAL AIR STATION ALAMEDA, CA</p>	<p>FIG. NO. 12</p>

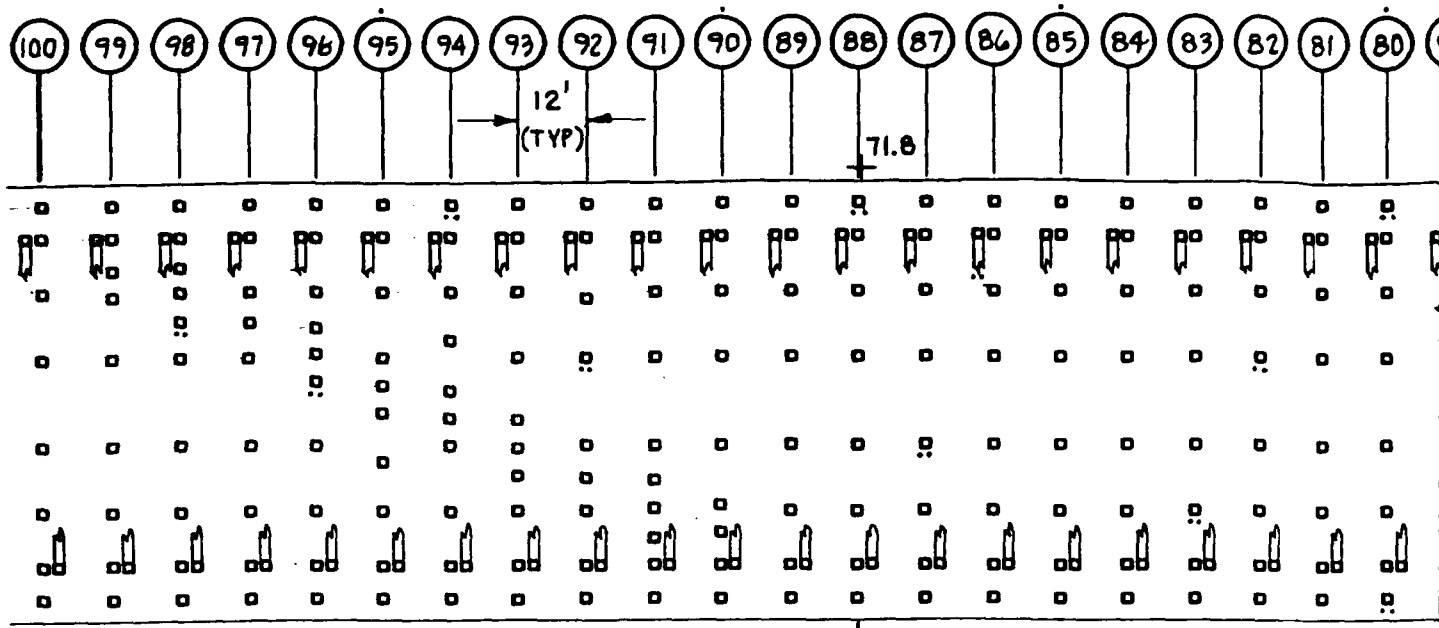

70.3 36 SPACES @ 12'-0" = 432'-0"  
 MATCH LINE - G (BENT NO. 100)

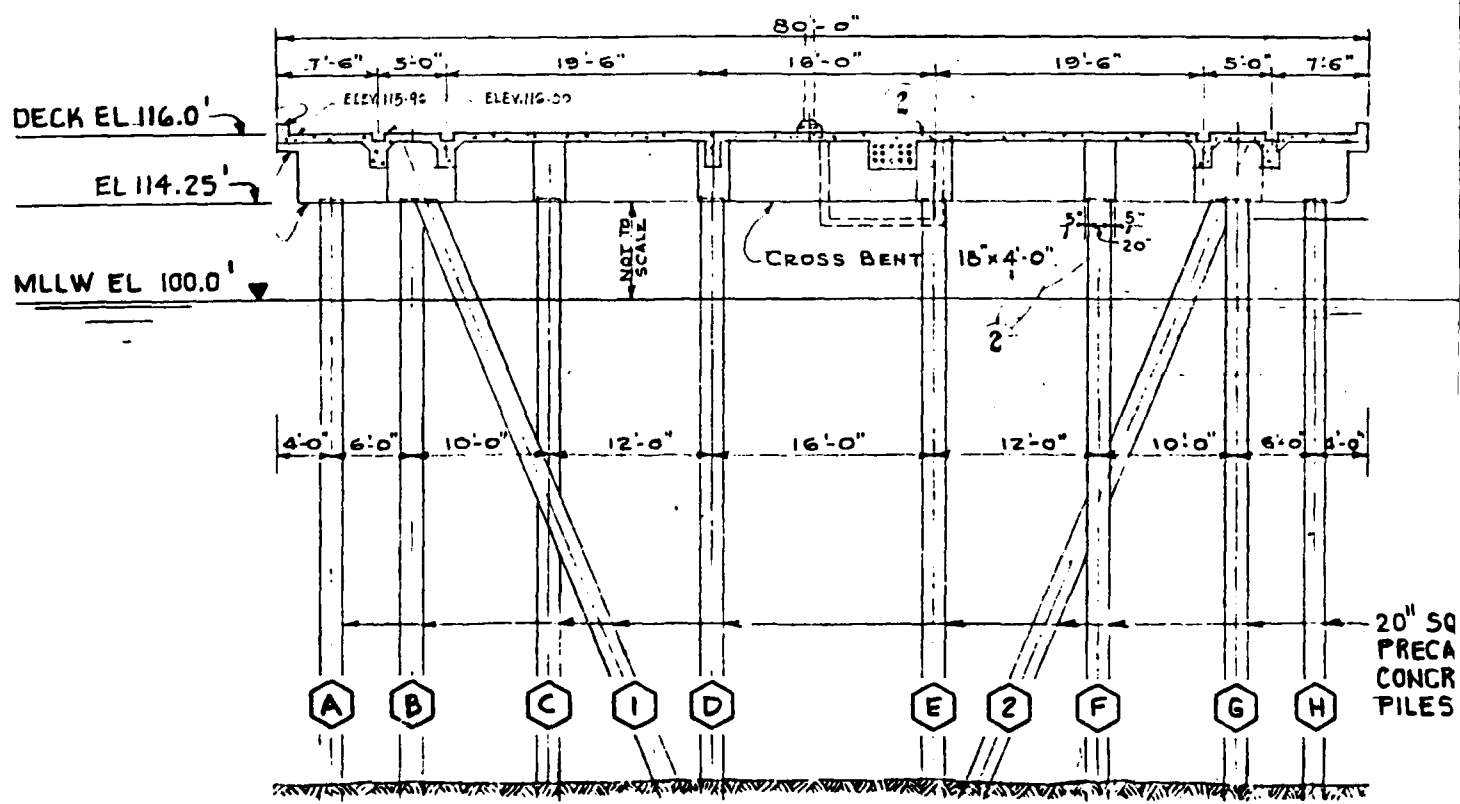

**NOTE:**  
 REFERENCE TAKEN FROM Y&D  
 DWG NO. 161,013 & NAVFAC  
 DWG NOS. 6018843 & 6018845.

**TYPICAL CROSS SECTION**  
 NOT TO SCALE

20" SQ  
 PRECA  
 CONCR  
 PILES

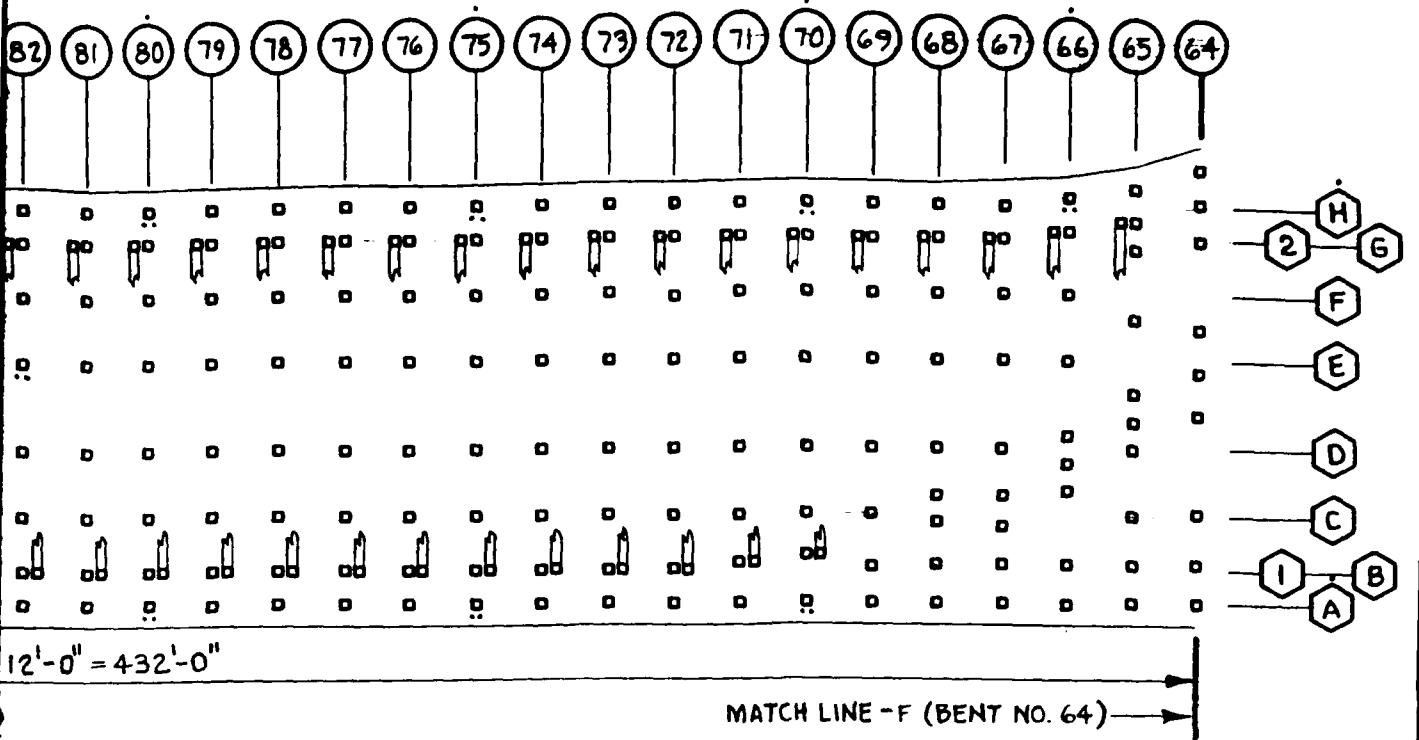

**PLAN**  
SCALE AS SHOWN

**LEVELS OF INSPECTION**

- ⊙ OR ⊕ LEVEL I (ALL PILES IN BENT OR ROW)
- LEVEL II

**LEGEND**

- ⊙ SEVERE DAMAGE (REQUIRES REPLACEMENT)
- ⊗ HEAVY SPALLING
- ⊘ LIGHT SPALLING
- 65.0 ELEVATION (MLLW EL 100.0')

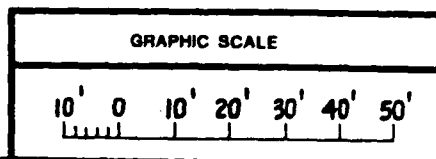
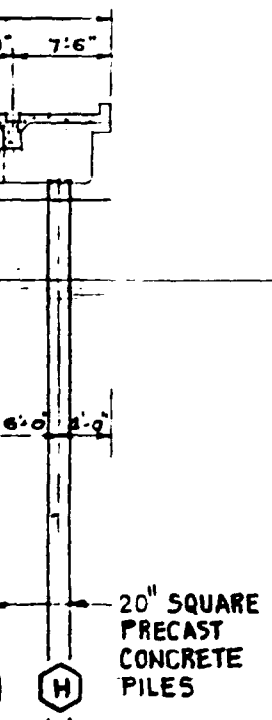

CHLDS ENGINEERING CORPORATION  
BOX 999  
MEDFIELD, MA

CHESAPEAKE DIVISION  
NAVAL FACILITIES ENGINEERING COMMAND  
WASHINGTON, D.C.  
NAVAL AIR STATION ALAMEDA, CA  
**PIER #2**  
FIG. NO. **13**

#### 4.3.2 OBSERVED INSPECTION CONDITIONS

In general, all of the piles in the newer section of the pier (Bents 148 through 165) are in excellent condition. Some light spalling was noted on one pile, however, this appeared to be the result of poor fabrication rather than structural deterioration.

Piles in the older section of the pier (Bents 147 through 64) are generally in good condition. Two piles, Pile A Bent 131 and Pile A Bent 130, have suffered severe structural damage (see Photos #8 and #9). These piles are cracked at the pile cap and at various locations along their length. They appear to have been hit by either a vessel or a camel and broke as a result of the impact.

Four of the piles inspected exhibit heavy spalling of concrete. In some cases rebar is exposed and corroding.

Eleven of the piles inspected exhibited light spalling (see Photos #10 and #11). The light spalling appears to be cosmetic and of no structural significance.

Several other piles in the old section of the pier exhibit minor cracking at the corners and some softness (less than 1/2") in the concrete. This condition is consistent with the age and exposure of the piles.

#### 4.3.3 STRUCTURAL CONDITION ASSESSMENT

The two severely damaged piles are no longer capable of supporting the design loads.

The heavily spalled piles, although capable of supporting the design loads, are considered marginal from a structural standpoint.

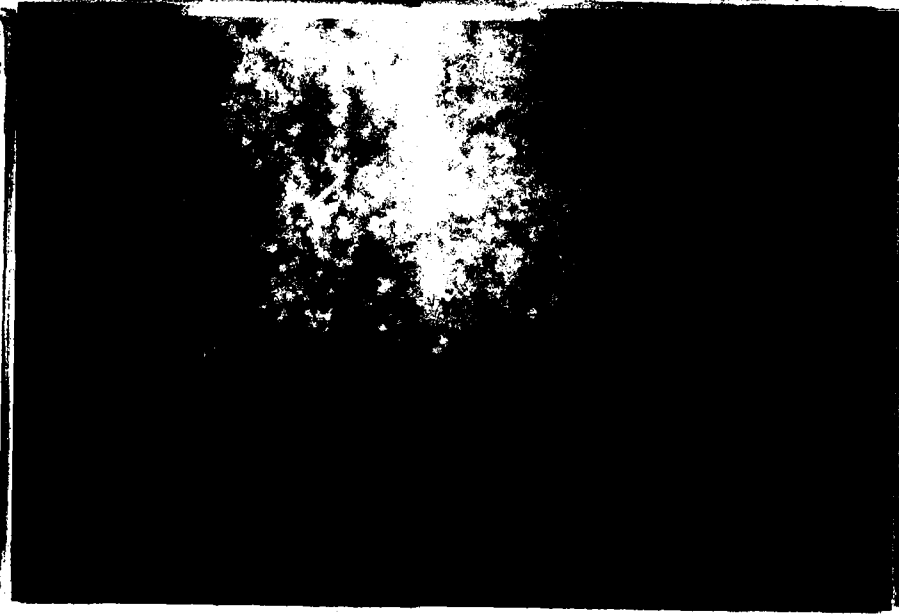

PHOTO #10: Pile A Bent 133, Elevation 99.0.  
Area of band cleaning and light  
spalling of pile corner.

PHOTO #11: Pile B Bent 124, Elevation 95.0.  
Area of light spalling on pile  
face. Note exposed aggregate.





PHOTO #12: Pile A Bent 11, Elevation 95.0.  
Cleaned area at pile corner.  
Note distinct chamfer edges  
indicating sound concrete.

PHOTO #13: Pile A Bent 12, Elevation 95.0.  
Light spalling at pile corner.



Continued deterioration of the concrete and corrosion of the rebar will reduce the load carrying capacity of the piles below design limits.

Piles which have light spalling or minor cracking and softness are sound. There is no significant loss in pile load carrying capacity.

#### 4.3.4 RECOMMENDATIONS

The two severely damaged piles, Pile A Bent 131 and Pile A Bent 130, should be repaired by driving two piles on either side of the damaged pile and casting a reinforced concrete cap between the new piles under the existing cap. The estimated cost for repairing a damaged pile by this technique is \$5,318.00. The total estimated cost for repairing the two piles is therefore \$10,636.00.

The piles exhibiting heavy spalling should also be repaired. We recommend that a reinforced concrete jacket be cast around the pile in the area of heavy spalling. The spalled area should be cleaned by chipping to sound concrete and the rebar cleaned or replaced as necessary.

It is estimated that a ten foot length of jacket would be sufficient to cover the deterioration noted on each pile. If a fabric form is used, the cost per 10' jacket would be \$1,320.00.

Since 30% of the total number of piles were inspected and four of these exhibited spalling, we expect that a total of 12 piles in the entire pier need jackets. The total cost to install 12 jackets is estimated to be \$15,840.00.

The recommended repairs should be accomplished as soon as possible. All repairs should be inspected after completion. The entire pier should be inspected in 5 years. The immediate inspection will insure that the repairs have been properly constructed. The follow-up inspection will determine the change of conditions with respect to time.

#### 4.4 WHARF NO. 1

##### 4.4.1 DESCRIPTION

Wharf No. 1 is located in the southern portion of the NAS Alameda, (see Figure 2). It is bordered to the north by Pier 1 and to the South by Pier 2. This wharf is functioning as an approach to Pier 2. When the wharf was built in 1941 it was 744' long and 40' wide. In 1945 it was widened by 50' to the inshore side. 20" square concrete piles were used in both cases, although in the 1945 addition the piles were jacketed in concrete from the cap down 13'. The jackets provide a 4" concrete cover on the faces of the piles. In all, there are approximately 472 vertical piles and 54 batter piles supporting the reinforced concrete deck (see Figures 14 and 15). The design live loading on the decks of both portions is 400 psf. The driven capacity of each pile is 50 tons.

Reference: Navy Department Bureau of Yards and Docks  
Y & D Drawings NOs. 317495, 161012 and 161016

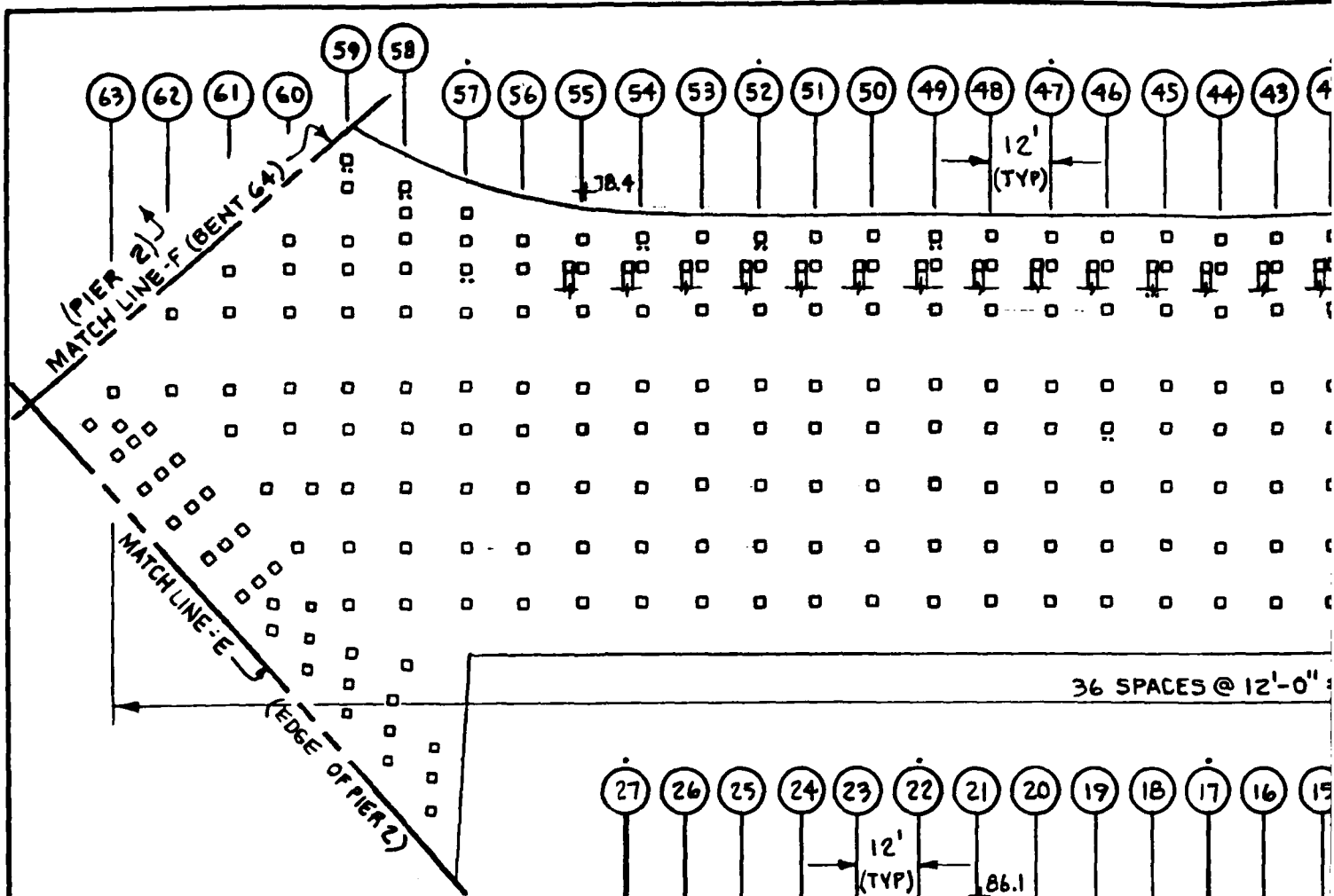

36 SPACES @ 12'-0"

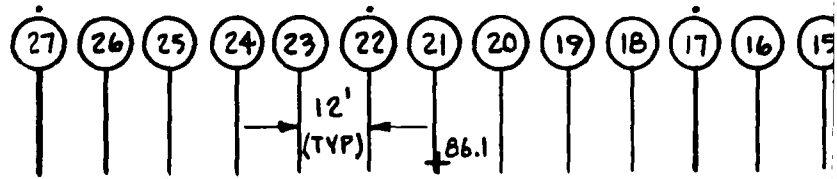

**LEVELS OF INSPECTION**

- ⊙ OR ⊠ LEVEL I  
(ALL PILES IN BENT OR ROW)
- LEVEL II

**LEGEND**

- ⊙ SEVERE DAMAGE  
(REQUIRES REPLACEMENT)
- ⊠ HEAVY SPALLING
- ⊞ LIGHT SPALLING
- 65.0 ELEVATION (MLLW EL 100.0')

**NOTE:**  
REFERENCE TAKEN FROM Y&D  
DWG NOS. 317,495, 161012, 161016.

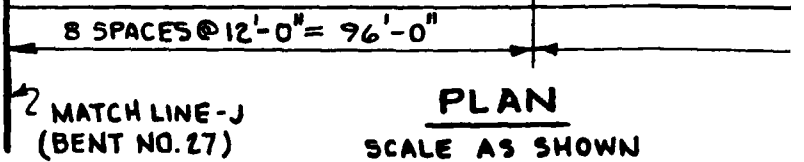

**PLAN**  
SCALE AS SHOWN

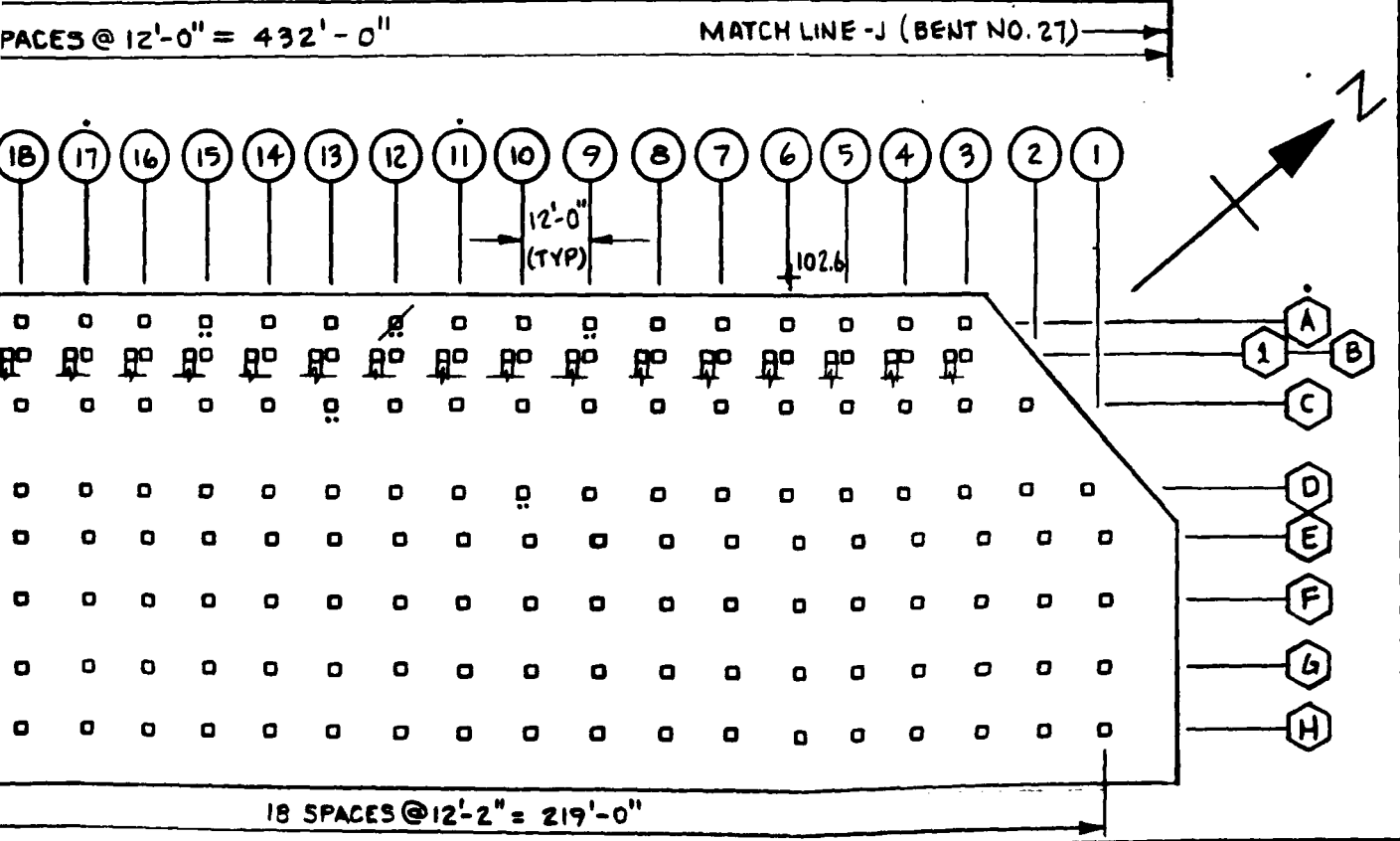
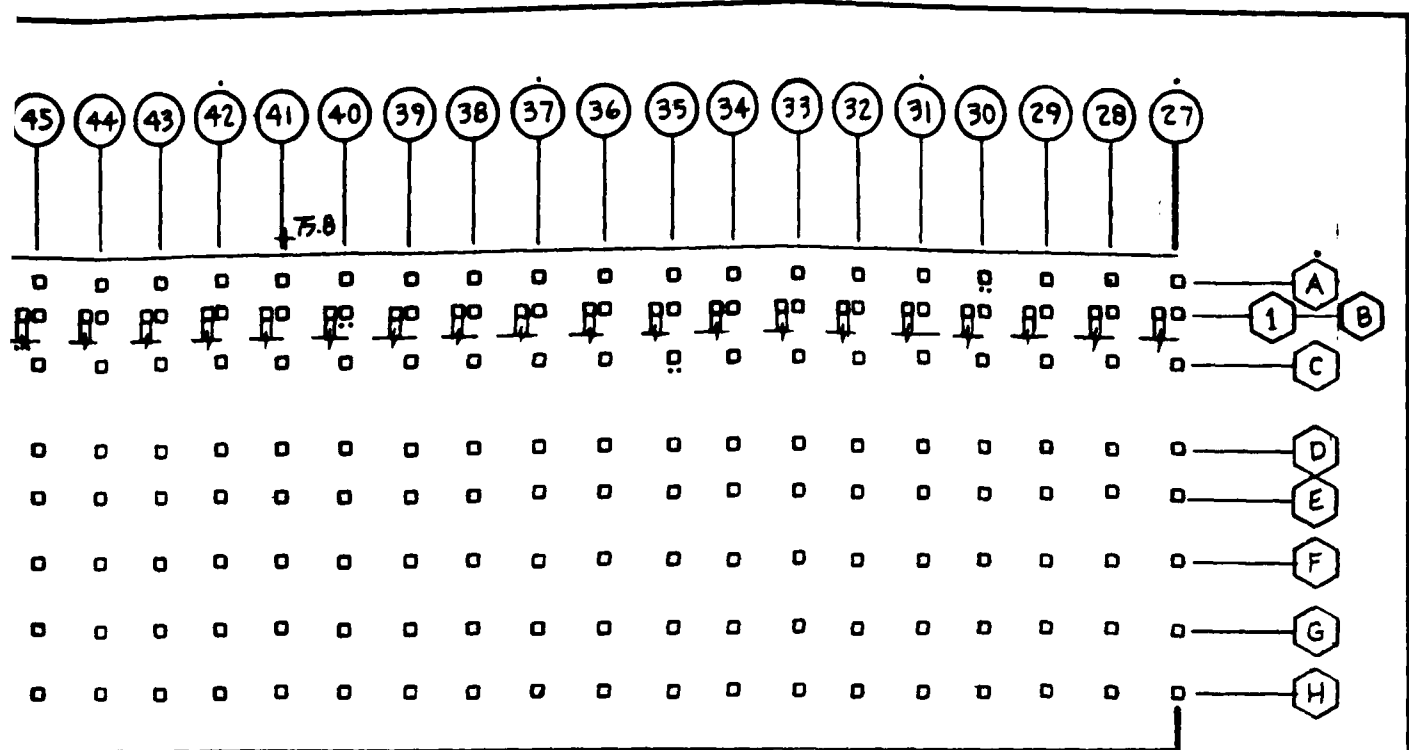

<p>GRAPHIC SCALE</p>	<p>CHILDS ENGINEERING CORPORATION BOX 233 MEDFIELD, MA</p>	<p>CHESAPEAKE DIVISION NAVAL FACILITIES ENGINEERING COMMAND WASHINGTON, D.C.</p>	
		<p>NAVAL AIR STATION ALAMEDA, CA</p>	<p>FIG. NO. 14</p>

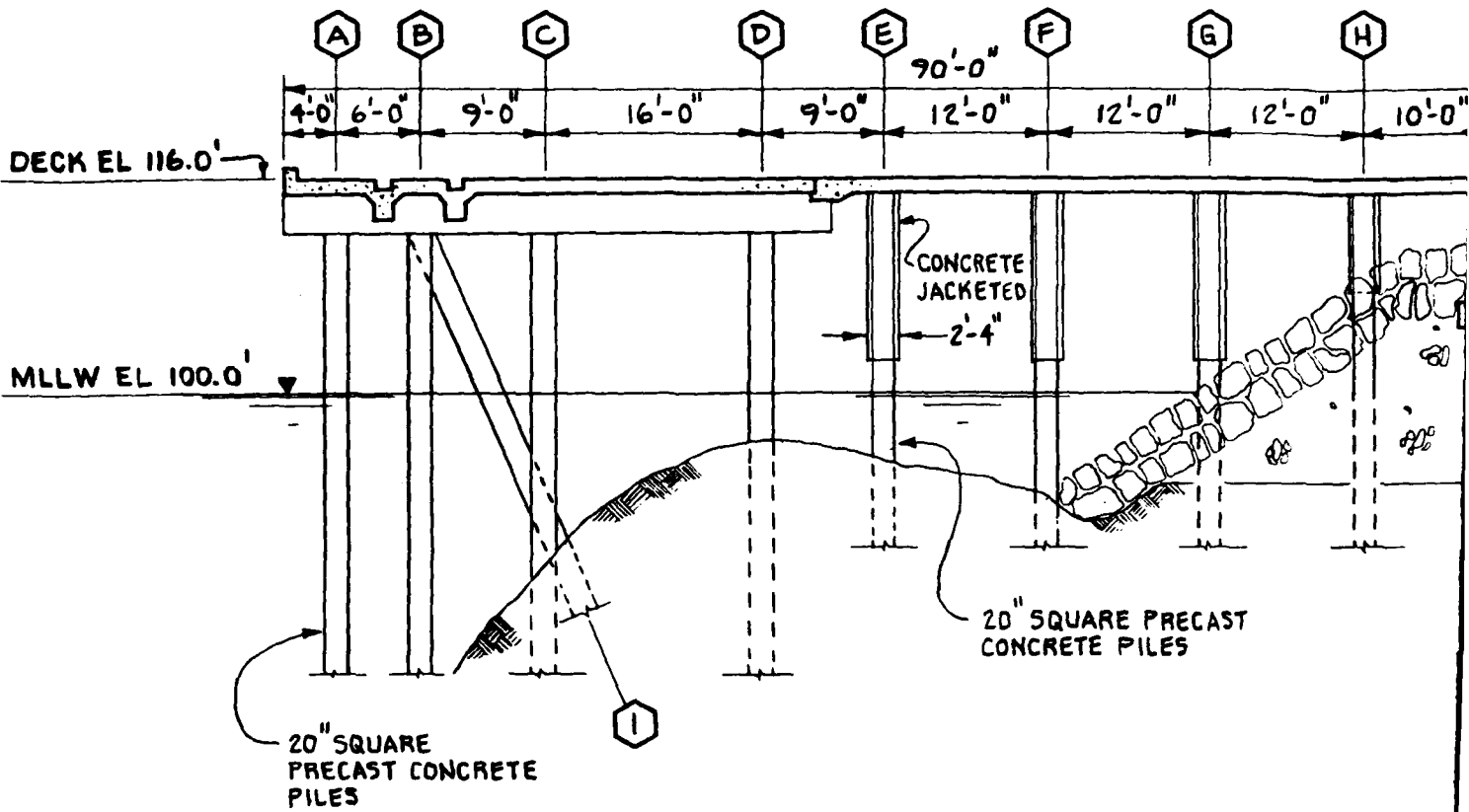

**TYPICAL CROSS SECTION**  
**SCALE AS SHOWN**

**NOTE:**  
 REFERENCE TAKEN FROM Y&D DWG NO. 317495.

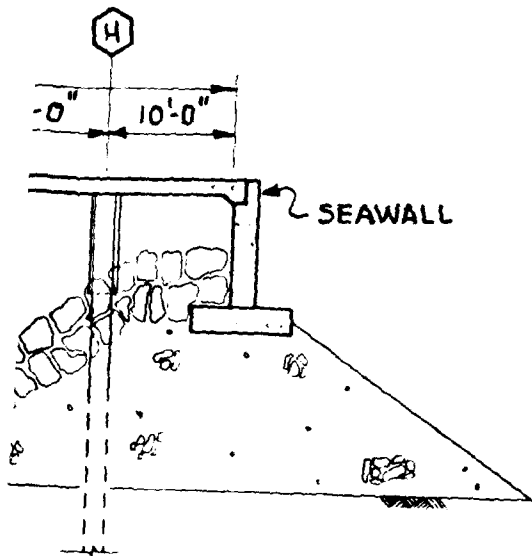

2

GRAPHIC SCALE		CHILDS ENGINEERING CORPORATION BOX 333 MEDFIELD, MA	CHESAPEAKE DIVISION NAVAL FACILITIES ENGINEERING COMMAND WASHINGTON, D.C.	
10'	5' 0'		NAVAL AIR STATION ALAMEDA, CA	FIG. NO. <b>WHARF #1</b> 15

17495.

#### 4.4.2 OBSERVED INSPECTION CONDITIONS

In general, all of the piles which were inspected are in good to excellent condition. Although the pier is over 40 years old, there has been very little deterioration of the concrete. Little or no softness in the concrete was observed, indicating that the original concrete mix was well-proportioned and resulted in a dense, impenetrable product (see Photo #12).

One of the piles inspected had some minor spalling (see Photo #13). The observed deterioration is cosmetic in nature and is of no real structural significance.

Vertical piles in the newer portion of the pier are protected with concrete jackets from the pile cap to approximately Elevation 102.0. The jackets were installed when the piles were driven. The jackets are in excellent condition and have protected the piles from deterioration in the tidal zone. No softness in the concrete jackets was noted.

#### 4.4.3 STRUCTURAL CONDITION ASSESSMENT

Since no significant structural damage to any of the piles was observed, there is no significant loss in pile load carrying capacity and, therefore, no loss in overall pier capacity.

Calculations of original pile capacities indicate that all piles have sufficient strength to support current use loading.

4.4.4 RECOMMENDATIONS

No repairs are recommended at this time.

The piles should be re-inspected in 5 years and this inspection should be used as a baseline to determine what, if any, deterioration has occurred.

## 4.5 PIER I

### 4.5.1 DESCRIPTION

This pier is located just north and parallel to Pier 2. It is also adjacent to the north end of Wharf 1 (see Figure 2).

Pier 1 is the smallest of the three piers having one berth of 500 feet available. It is primarily used for berthing one AOR, DD, or AFS type ship. The present state of this pier is sub-standard.

The pier is of an earth-filled cellular-steel sheet pile construction. It was built in 1937 and is approximately 650' long and 50' wide (see Figure 16). The bituminous deck is supported by an earth fill. Live loading on the deck is currently restricted to prevent vehicular traffic.

Reference: Navy Department Bureau of Yards and Docks  
Y & D Drawings Nos. 126348 and 126349

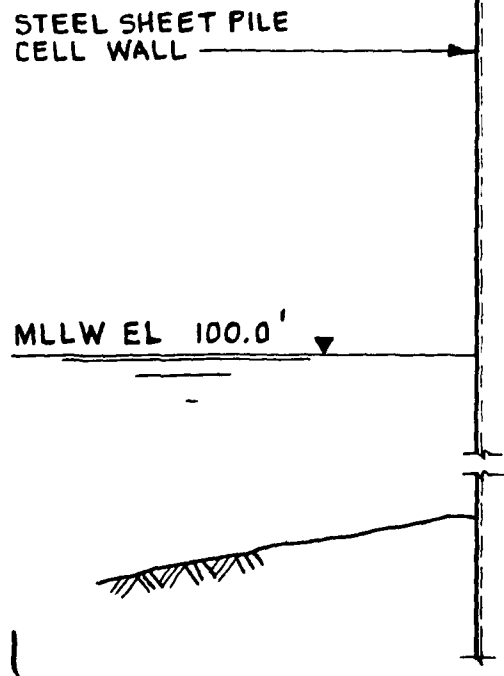
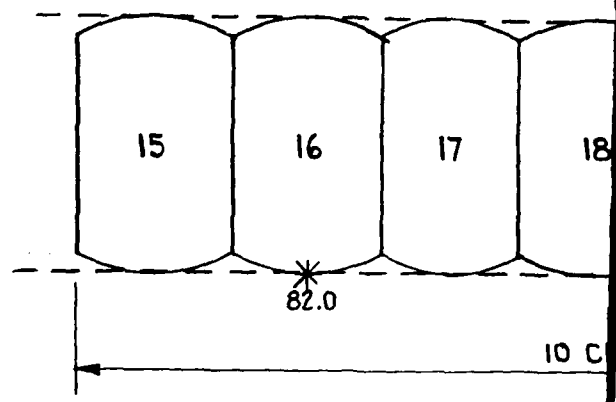
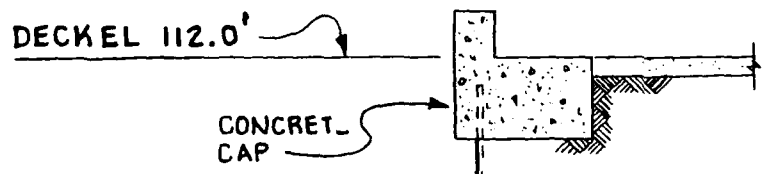
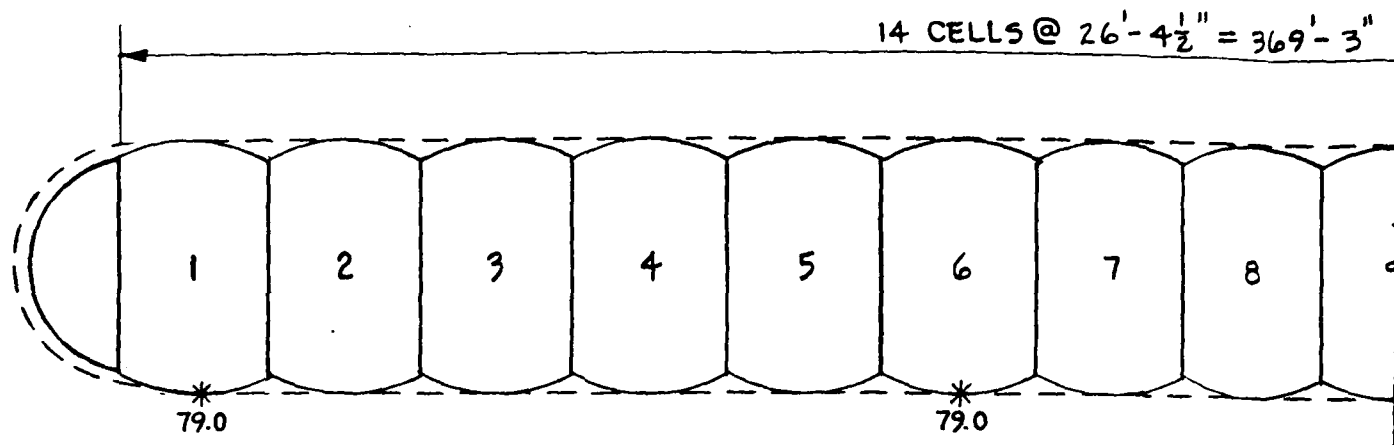

PLA  
SCALE AS

LEGEND

- 78.0 - ELEVATION (MLLW EL 100.0')
- \* - LOCATION OF D-METER STATION

TYPICAL CROSS SECTION  
NOT TO SCALE

NOTE:  
REFERENCE TAKEN FROM Y&D  
DWG NOS. 126348 & 126349.

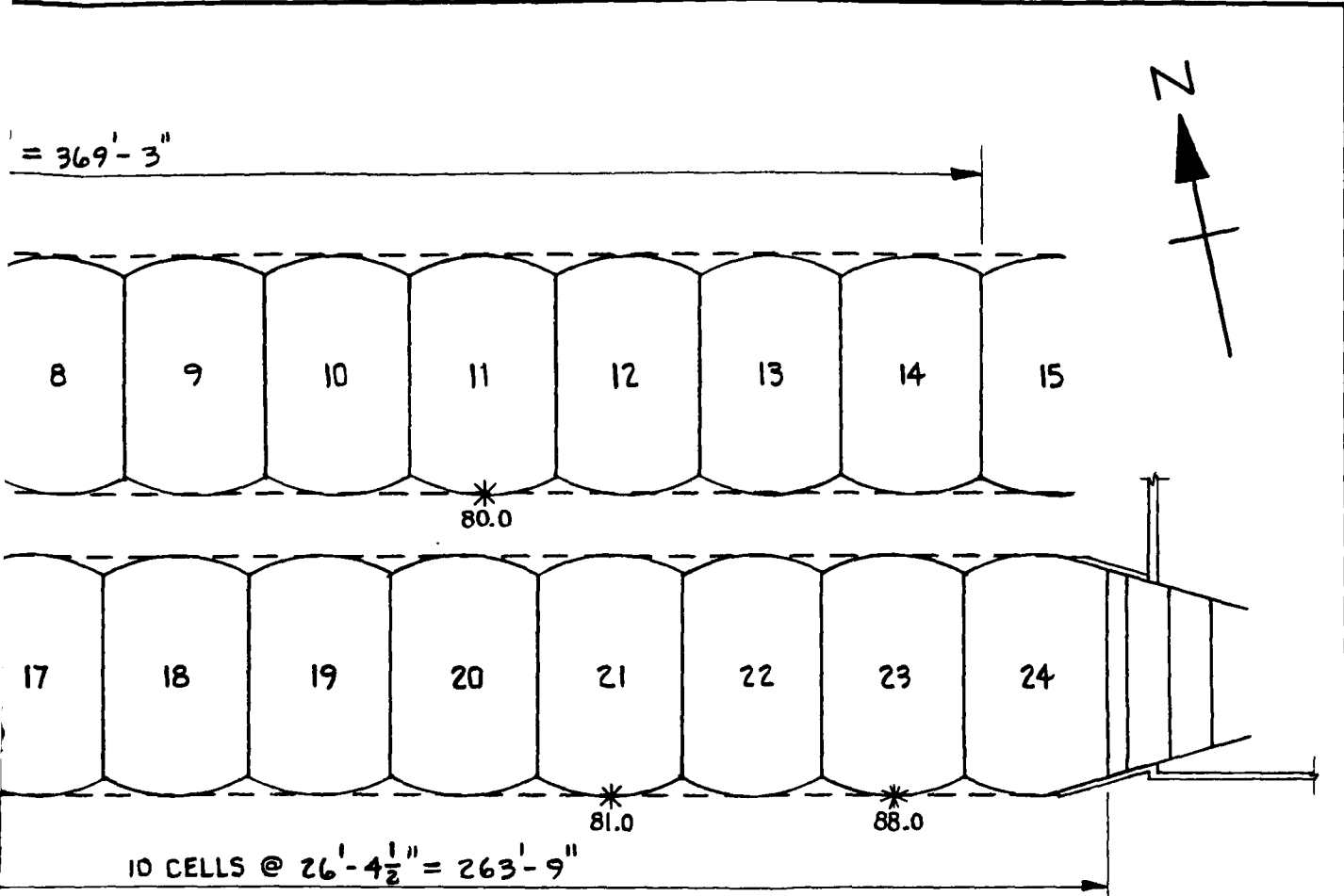

**PLAN**  
SCALE AS SHOWN

W EL 100.0')  
METER STATION

2

GRAPHIC SCALE	CHILDS ENGINEERING CORPORATION BOX 232 MEDFIELD, MA	CHESAPEAKE DIVISION NAVAL FACILITIES ENGINEERING COMMAND WASHINGTON, D.C.	
10' 0 10' 20' 30' 40' 50' 		NAVAL AIR STATION ALAMEDA, CA <b>PIER #1</b>	FIG NO <b>16</b>

Y&D  
49.

#### 4.5.2 OBSERVED INSPECTION CONDITIONS

The pier is currently closed to vehicular traffic. This restriction has been in effect for many years and is the result of several cave-ins in the deck surface. The cave-ins are apparently the result of loss of cell fill through holes in the steel sheet piles created by corrosion and on impact damage.

During the inspection period, the north side of the pier was inaccessible.

Over the past several years, Station Personnel have patched better than twenty holes in the steel sheet piling and have patched several cave-ins of the deck.

During the inspection several steel sheet pile patches were observed. The newer patches look to be in good condition while the older patches appear corroded.

Several holes were observed during the inspection. Typically, the holes are approximately 8"  $\emptyset$  (see Photo #14).

The steel sheet piling exhibits varying degrees of corrosion from the pile cap to the mudline. Frequently corrosion nodes (see Photo #15) were noted. These nodes are basically corrosion by-product which when removed reveal a significant pit in the steel. The pits ranged in diameter from 1/8" to 5/8" and up to 1/8" deep. Photo #16 illustrates a typical steel sheet pile at the mudline. Other deterioration included corrosion splits at the sheet pile interconnects (knuckles). This condition is not unusual and is the result of corrosion occurring in a high stress area (see Photo #17).



PHOTO #14: Cell #23, south side.  
Elevation 95.0. 8"  $\emptyset$  hole in  
steel sheet pile. Note gravel  
fill within cell.

PHOTO #15: Typical corrosion node.



Steel thickness measurements were taken at several locations along the pier and at several elevations at each location. The severe pitting in the area around mean low water (Elevation 100±) made obtaining the readings very difficult. The results of the measurements are included in the Appendix. The range of deterioration was broad. In some areas, no metal loss was measured while others (holes) had 100% metal loss. The average metal loss based on the measurements is approximately 20%. Since many readings were not possible in the pitted areas (usually high corrosion areas), we feel that the actual average metal loss is closer to 40% or 50%.

#### 4.5.3 STRUCTURAL CONDITION ASSESSMENT

Pier 1 is in poor condition. Although the patching which has been performed by Station Personnel is eliminating the deck cavities by maintaining the earth fill within the cells, it is not strengthening the sheet piling.

The loss of metal along the cell walls increases the tension stress in the steel. The corrosion holes (split) at the sheet pile knuckles are an indication of high stress corrosion.

Elimination of vehicular traffic on the pier has helped reduce stresses in the steel by decreasing the lateral load generated by the earth fill within the cells.

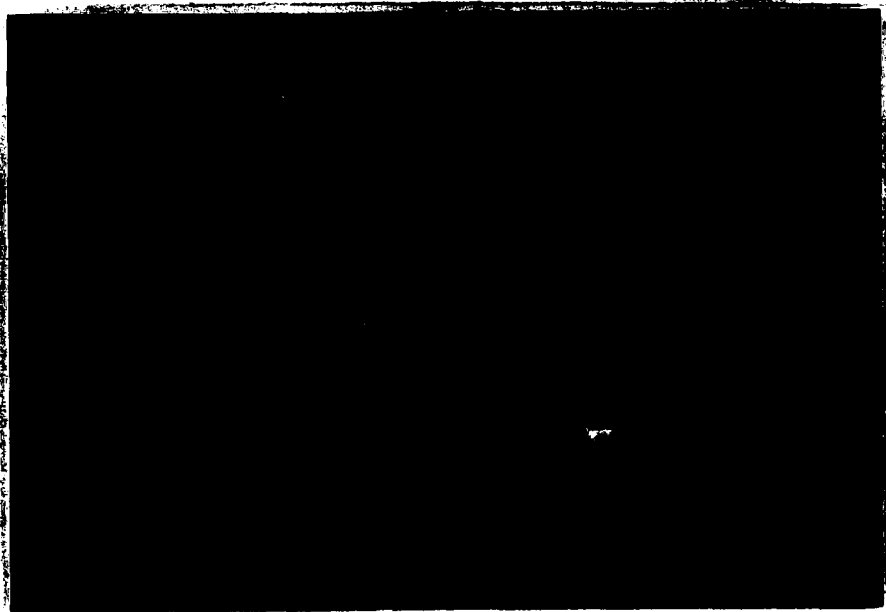

PHOTO #16: Typical condition of steel sheet piles at the mudline.

PHOTO #17: Typical corrosion hole in sheet pile knuckle.



#### 4.5.4 RECOMMENDATIONS

We recommend that the current vehicle restriction continue and that the hole patch program continue until more permanent repairs can be made.

Although it is difficult to determine the point at which sufficient corrosion has occurred to increase stresses in the steel to a point of failure, we feel that this point is not far away. It is our understanding that the pier is scheduled for major repair or even replacement in the mid-1980's. We recommend that this schedule be followed since a delay could lead to a significant failure.

There are several factors to be considered in determining whether to repair the pier or replace it, not the least of which is anticipated pier use.

There are several alternative repair techniques which could be used if a decision is made to repair rather than replace. One technique would be to install a new steel sheet pile wall around the existing pier. The new wall should be tied into the existing wall and the void between the new and old walls filled with either concrete or gravel. The estimated cost to drive a new steel sheet pile wall and backfill it around the existing wall is approximately \$4,000.00 per lineal foot.

To encapsulate the entire pier, the estimated cost is \$5,400,000.

#### 4.6 BULKHEAD (PARKING APRON NO. 4)

##### 4.6.1 DESCRIPTION

The bulkhead is located north of and parallel to Pier 1 and includes Seaplane Ramps 1, 2 3 and 4 (see Figure 2). Presently, the seaplane ramps are not being utilized by seaplanes, they are being used as a storage and deployment area for oil booms. Originally, the bulkhead was constructed in 1939. Sometime after that, an addition in the form of an extended pile cap and batter piles appeared on the bulkhead (see Figure 17).

References: Navy Department Bureau of Yards and Docks  
Y & D Drawing No. 126533.  
Department of the Navy Naval Facilities Engineering  
Command 0 NAVFAC Drawing No. 638436.

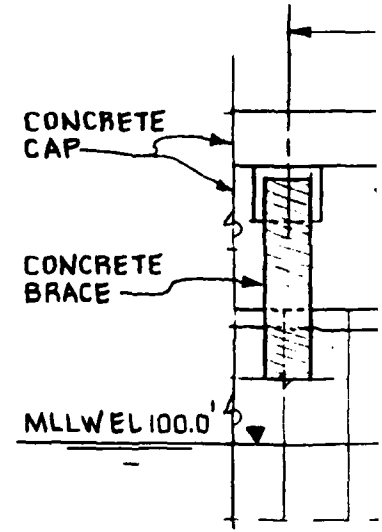
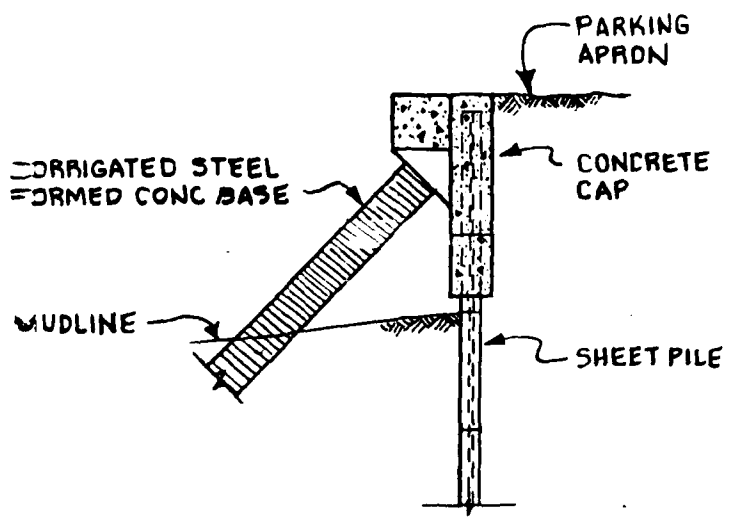

TYPICAL CROSS SECTION  
 NO SCALE

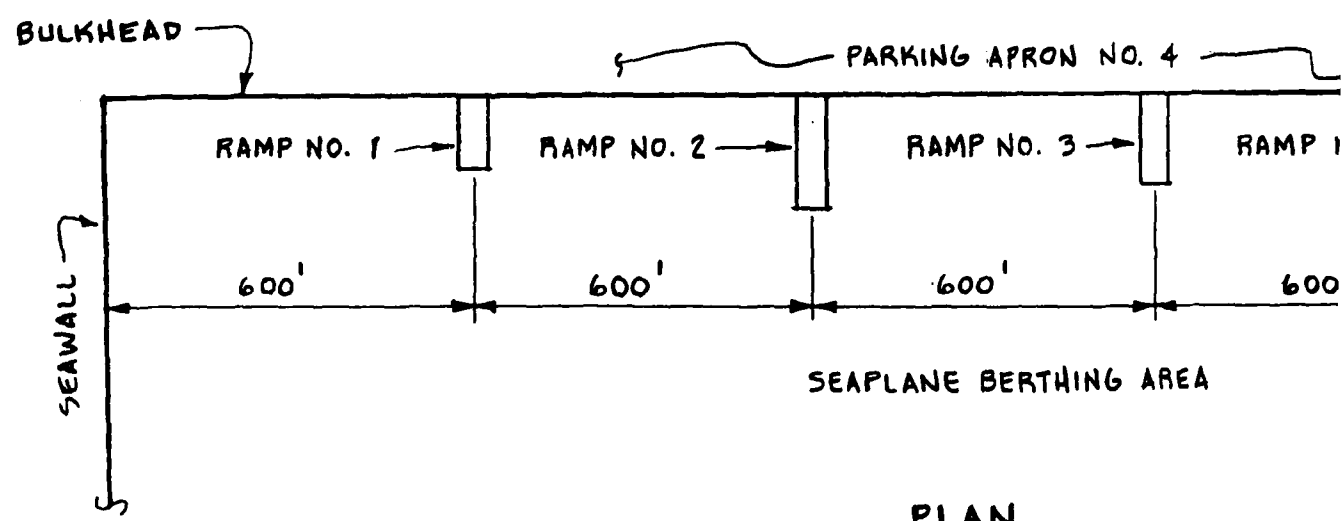

PLAN  
 SCALE AS SHOWN

**NOTE:**  
 REFERENCE TAKEN FROM NAVFAC DWG NO. 638456 & Y4D DWG NO. 126533.

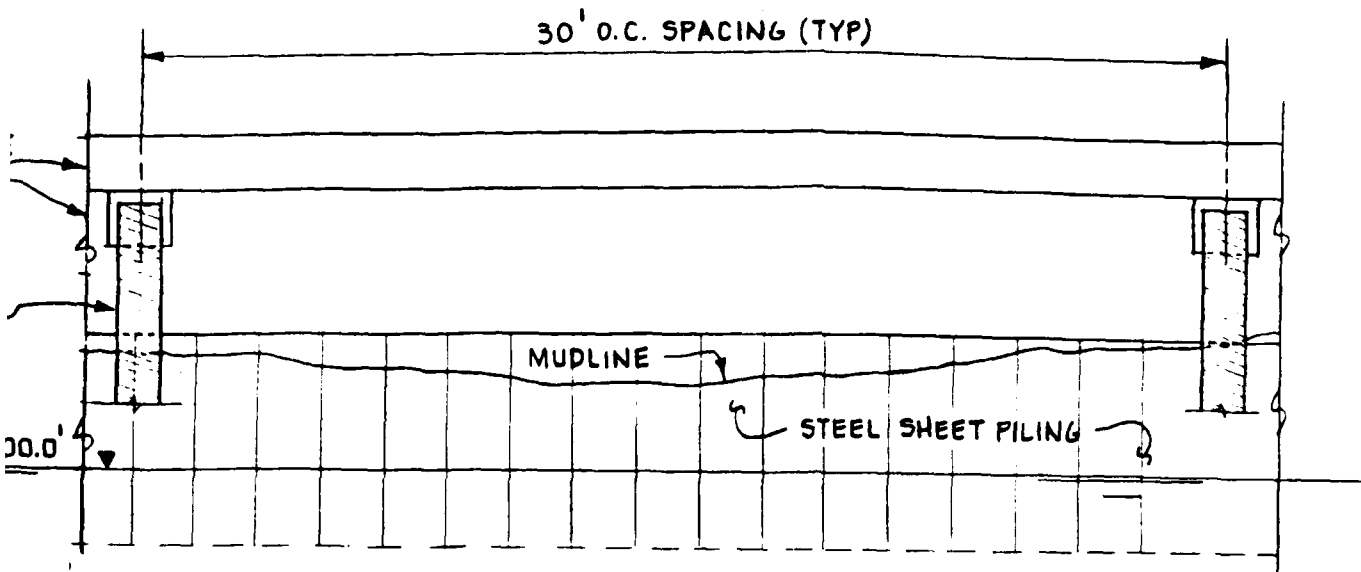

ELEVATION  
NO SCALE

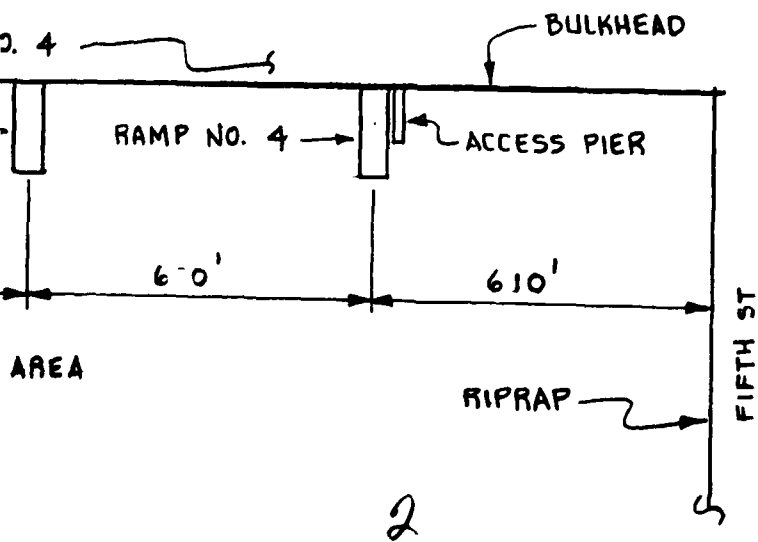

<p>GRAPHIC SCALE</p> <p>300' 200' 100' 0 300'</p>	<p>CHILDS ENGINEERING CORPORATION BOX 333 MEDFIELD, MA</p>	<p>CHESAPEAKE DIVISION NAVAL FACILITIES ENGINEERING COMMAND WASHINGTON, D.C.</p>	
		<p>NAVAL AIR STATION ALAMEDA, CA</p> <p><b>BULKHEAD</b></p>	<p>FIG. NO <b>17</b></p>

#### 4.6.2 OBSERVED INSPECTION CONDITIONS

In general, the bulkhead appears to be in good condition. There does not appear to be any significant misalignment along the bulkhead which would indicate yielding of the wall. The concrete encasement around the steel sheet piling is in good condition and shows little sign of deterioration. The encasement concrete is sound.

Thickness measurements of the steel sheet piling indicate metal loss of less than 10%. This is probably attributable to the fact that the original design called for backfilling in front of the sheeting about halfway up the concrete encasement. The fill in front of the wall would have served as a barrier against corrosion. At present, there are several locations (approximately 50% of the length) along the wall where the steel sheeting is exposed. Maximum exposure is approximately 2 feet (see Photo #18).

Batter piles were added to the wall sometime after the original construction (see Photo #19). These piles were tied into the bulkhead by extending the concrete encasement to form a concrete wall cap.

The batter piles are corrugated steel shells filled with concrete. The condition of the shells is poor since much of the metal is corroded, however, the concrete within the shells appears sound.

The wall cap extension which is used to tie in the batter piles is in fair condition. The upper and lower edges of the concrete have spalled in many locations. In some instances, rebar is exposed in the spall areas and is corroded.

Associated with the bulkhead are four seaplane ramps and one access pier. In all cases they are being used as staging areas for oil



PHOTO #18: Typical condition of concrete encasement with steel sheet piles exposed at base.

PHOTO #19: Overview of Bulkhead. Note spalling at edge of concrete cap.



booms and no longer serve in their original design function.

All of the ramps and the pier are reinforced concrete decked with steel H-pile supports. Several of the ramp surfaces have large spalled areas where rebar is exposed.

Thickness measurements of remaining steel on one H-pile in the access pier indicate substantial metal loss due to corrosion.

#### 4.6.3 STRUCTURAL CONDITION ASSESSMENT

The bulkhead is in good condition. No major structural anomalies were found which would detract from its capacity.

The deterioration of the concrete wall cap should be stopped to prevent weakening of the batter pile system.

The deterioration of the ramp decks is consistent with its estimated age and environmental exposure. The deterioration would be structurally significant if the ramps were used as designed. However, since they are used only as oil boom staging and storage areas, the spalling of the concrete has little or no structural significance.

The deterioration of the H-piles supporting the ramps and access pier is also of little structural significance based on current use.

#### 4.6.4 RECOMMENDATIONS

The spalled corners of the concrete wall cap should be repaired by cleaning to sound concrete, cleaning and/or replacing deteriorated rebar and patching with pneumatically applied concrete. This will prevent deterioration of the batter pile support system.

Fill should be placed in front of the wall to original design levels. This will eliminate corrosion of the steel sheet pilings.

The estimated cost of repairing the wall cap is \$18,000.00 and filling in front of the wall is \$43,000.00.

All repairs should be inspected after completion. The entire pier should be inspected in 5 years. The immediate inspection will insure that the repairs have been properly constructed. The follow-up inspection will determine the change of conditions with respect to time.

## 4.7 PIER 4

### 4.7.1 DESCRIPTION

Pier 4 is located on the northernmost boundary of the NAS Alameda, in the area of the Fuel Supply Point (see Figure 2). Presently it is being used as a fuel pier. It is a "T" shaped pier that extends approximately 100' outshore. The outshore end of the pier is 160' long and 5' to 15' wide while the inshore section is 13' wide, (see Figure 18). The wooden plank decking is supported by 48 timber piles. Concrete jackets have been placed on 41 piles for their full length. The pier was built in 1953.

Reference: Department of the Navy Naval Facilities Engineering  
Command - NAVFAC Drawing No. 1250175

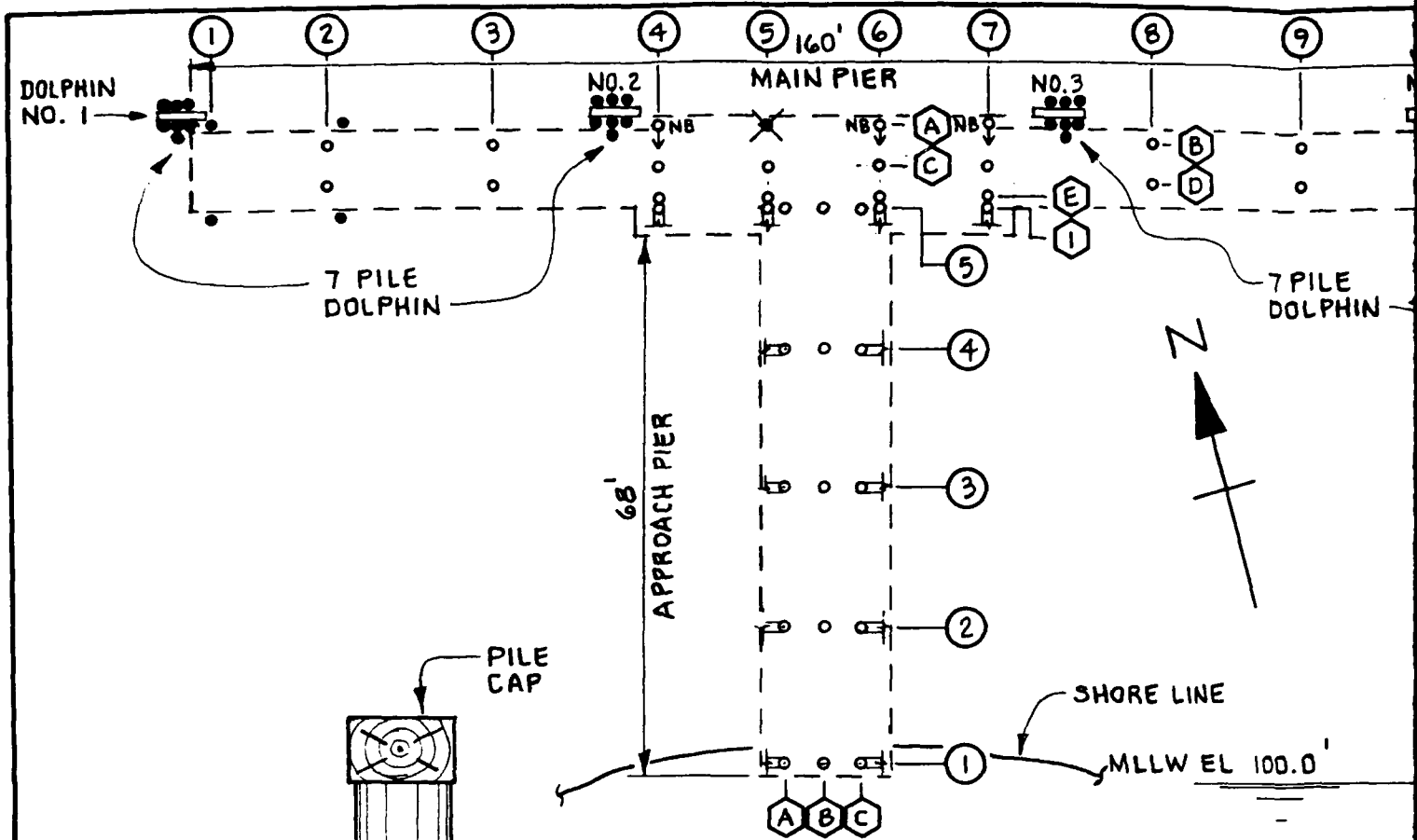

**PLAN**  
NOT TO SCALE

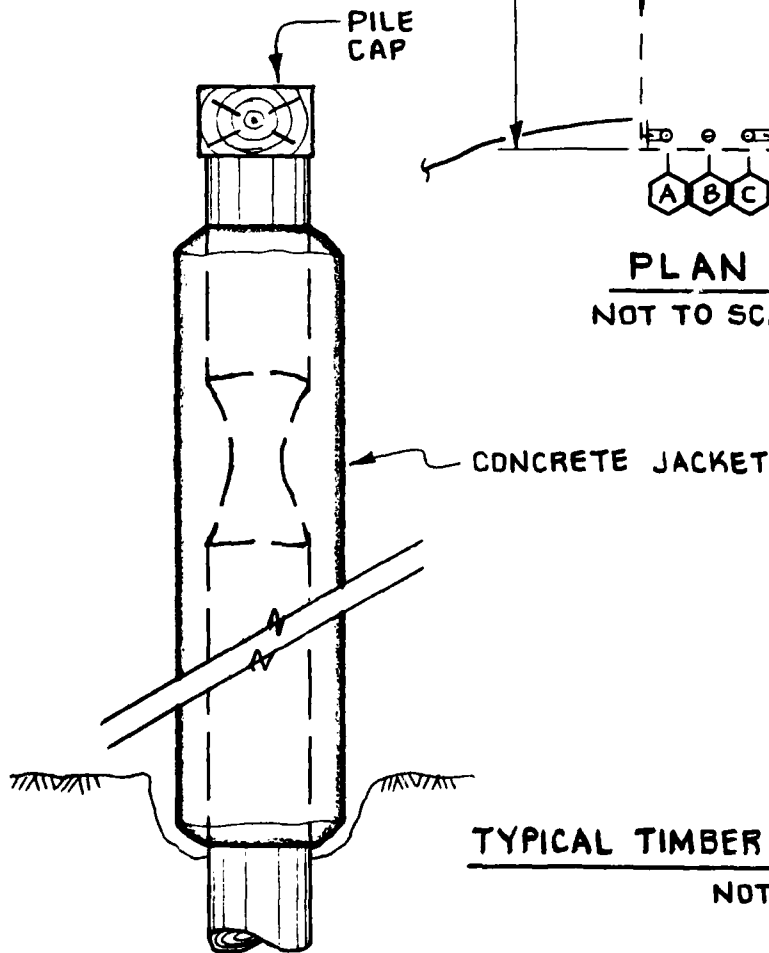

**TYPICAL TIMBER PILE WITH CONCRETE JACKET**  
NOT TO SCALE

**NOTE:**  
REFERENCE TAKEN FROM NAVFAC DWG NO. 1250175.

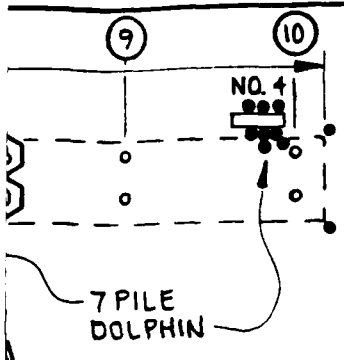

**LEGEND**

- SHADED PILES ARE NEW
- ALL OTHERS HAVE BEEN JACKETED
- NO ♀ PILE DISPLACED & NOT BEARING
- ✕ PILE MISSING

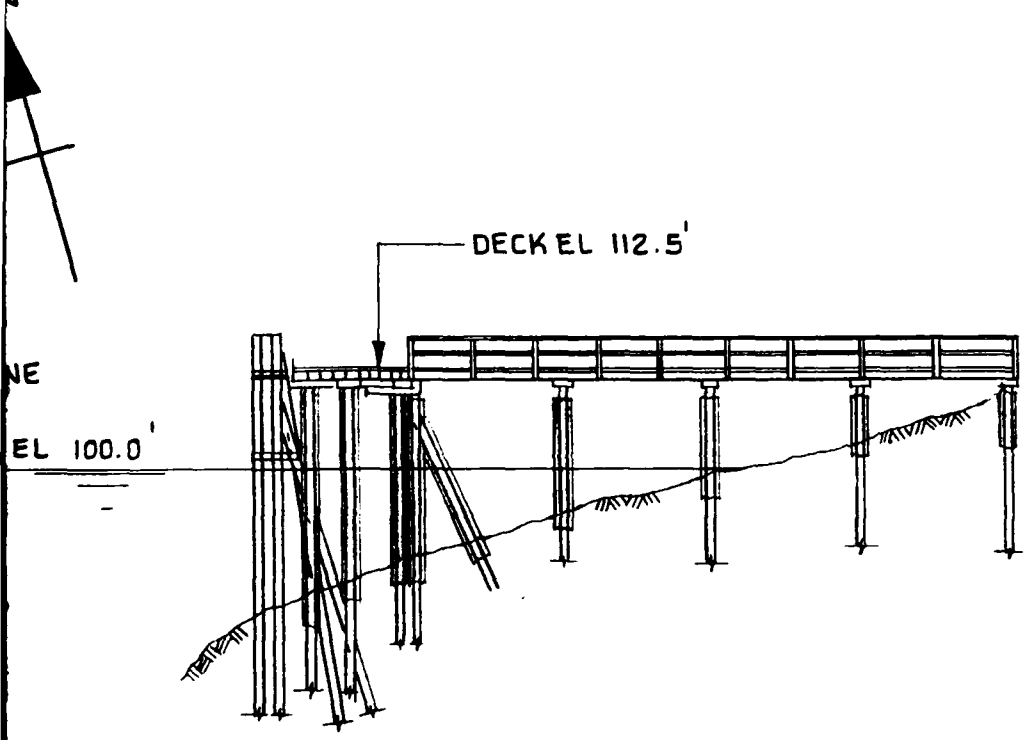

ELEVATION  
NOT TO SCALE

E JACKET

2

FIG NO. 1250175.

GRAPHIC SCALE	CHILDS ENGINEERING CORPORATION BOX 333 MEDFIELD, MA	CHESAPEAKE DIVISION NAVAL FACILITIES ENGINEERING COMMAND WASHINGTON, D.C.	
NA		NAVAL AIR STATION ALAMEDA, CA	FIG NO <b>18</b>

**PIER #4**

#### 4.7.2 OBSERVED INSPECTION CONDITIONS

In general the piles are in good condition.

One pile, Main Pier Pile A Bent 5 is displaced completely from the pile cap and broken but still connected at the mudline.

The three remaining piles along the north face of the product handling area (Main Pier Pile A Bents 4, 6 and 7) are slightly displaced and no longer bearing fully on the pile cap (see Photo #20).

The original piles are all jacketed in concrete from the mudline to approximately 3' below the pile cap. Most of the jackets are buried in the mud except for the piles in Bents 1, 2 and 3 of the Approach Pier. These jackets stop approximately 6" above the mudline.

In general the submerged section of the pile jackets are in good condition and the concrete is sound (see Photo #21). The upper 3 to 4 feet of the jackets exhibit varying degrees of deterioration, including cracking and spalling of the concrete.

Several new piles have been driven to replace the old pier support pilings and to replace 4 - seven-pile breasting dolphins. In general the new piles are in good condition and still well-preserved by creosote. However, a few piles have suffered attack by marine borers (see Photo #22).

The older piles were probably jacketed as a result of marine borer damage and to protect against continued borer attack.



PHOTO #20: Typical displaced pile head. Similar conditions found Pile A Bents 4, 6 and 7 of the Main Pier.

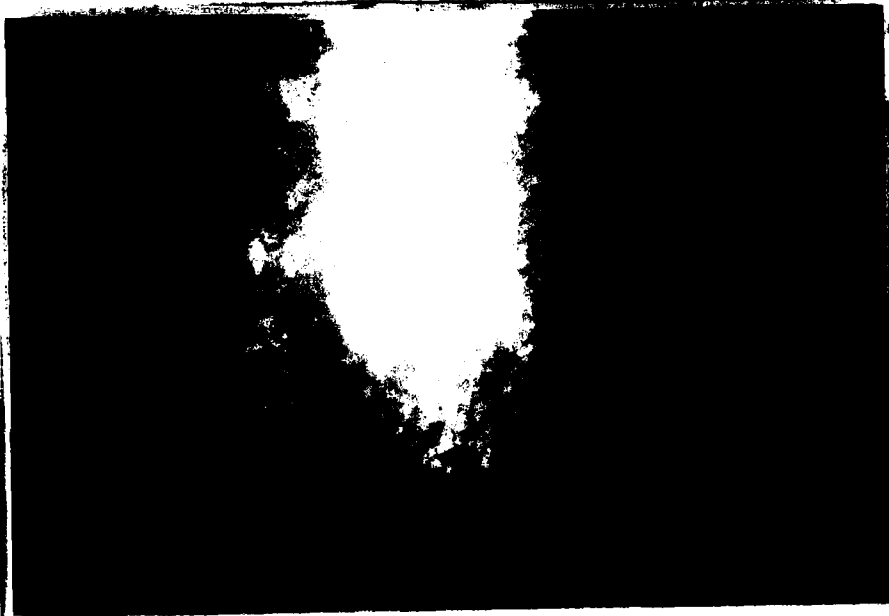
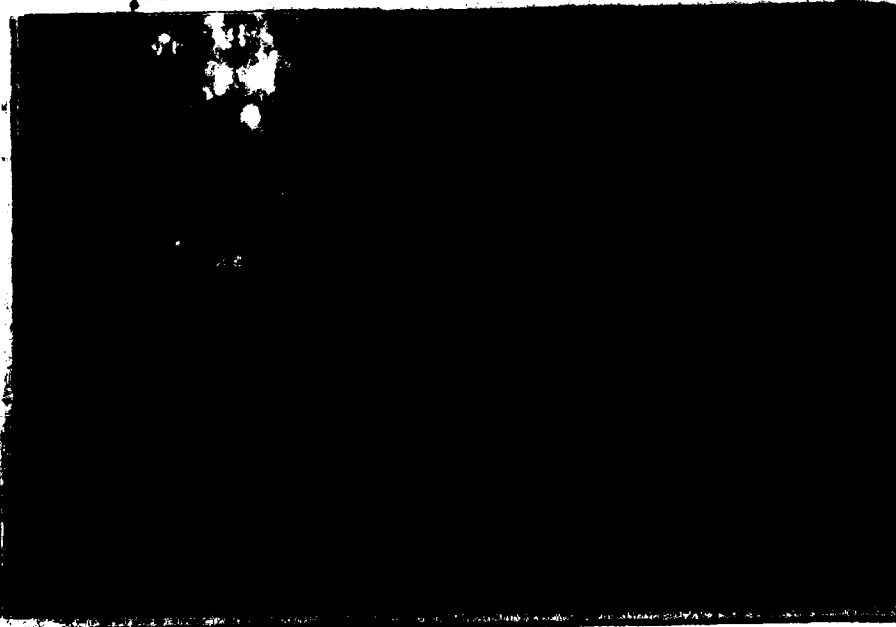

PHOTO #21: Typical condition of concrete jacket. Note zipper for closing fabric forms.

PHOTO #22: Typical marine borer trench found in some of the newer piles near the mudline, Southwest pile, Dolphin No. 3.



#### 4.7.3 STRUCTURAL ASSESSMENT

The damage along the north face of the product handling area is the result of vessel impact. There is a camel which lays along this front row of piles which extends beyond the breasting dolphins. Therefore, when vessels berth at the pier they impact the camel, which in turn, impacts these four pilings.

The one broken and displaced piling is no longer capable of supporting load and should be replaced.

Piles not bearing 100% at the cap may cause damage to the piles or the pile cap by crushing under heavy loads. The piles should be re-positioned, refastened and shimmed as necessary to attain full bearing.

Along the Approach Pier where the pile jackets do not extend to the mudline, the mudline should be raised. By backfilling around the piles and covering the exposed timber, the possibility of borer attack will be eliminated.

The newer piles which exhibit borer attack indicate that marine borers are still present and active in the area. Since the dolphin piles are subject to vessel impact by design, jacketing of the piles is not possible.

#### 4.7.4 RECOMMENDATIONS

The broken pile should be replaced as soon as possible. The displaced piles should be re-positioned, refastened and shimmed to obtain full bearing.

To eliminate possible future damage of these piles, we recommend removal of the existing camel. If camels are necessary for the operation of the facility, they should be attached to the breast- ing dolphins.

The exposed portions of the jacketed piles in the Approach Pier should be backfilled. We recommend the placement of bags contain- ing underwater concrete around the exposed portion of the pile.

The estimated cost for replacing the existing damaged pile with a new treated timber pile is \$4,000.00. The re-positioning, re- fastening and shimming of three piles is estimated to cost \$500.00 per pile for a total of \$1,500.00.

The backfilling with underwater concrete filled bags around the Approach Pier piles is estimated to cost \$5,000.00.

All repairs should be inspected after completion. The entire pier should be inspected in 5 years. The immediate inspection will insure that the repairs have been properly constructed. The follow-up inspection will determine the change of conditions with respect to time.

**CHILDS ENGINEERING CORPORATION**

Box 333  
MEDFIELD, MA 02052

JOB 498-81 1+lamada  
SHEET NO. 1 OF         
CALCULATED BY DLP DATE 10/11  
CHECKED BY CDS DATE         
SCALE       

20" Sq. concrete pile  $l = 50' = 600''$

Long Column (Euler):

$$P' = [0.8 (.225 F_c' + f_s P_g)] \left(1.3 - \frac{.03 l}{t}\right)$$

assume 3000 psi conc.  $f_s = 16 \text{ ksi}$

$$P' = [0.8 (400 \text{ in}^2) [.225 (3000 \text{ psi}) + 16,000 \text{ psi} \left(\frac{6.28 \text{ in}^2}{400 \text{ in}^2}\right)]] \times \left(1.3 - \frac{.03 (600'')}{20''}\right)$$

$$P' = [320 (675 + 251.2)] (.4) = 118,554 \# = 59.3 \text{ tons}$$

59.3 tons > 50 tons which is largest driven capacity - o.k.

Check local col. consideration for heavily spalled piles:

$$P' = [0.8 A_g (.225 F_c' + f_s P_g)]$$

$$P' = [0.8 (201) (675 + 251.2)] = 148,933 \#$$

$$= 74.4 \text{ tons} > 50 \text{ tons}$$

O.K.

$A_g = \text{Reduced}$

area -

20" x



16"  $\phi$

$$= \frac{\pi d^2}{4} = 201 \text{ in}^2$$

CHILDS ENGINEERING CORPORATION  
Box 333  
MEDFIELD, MA 02052

JOB 498-81  
SHEET NO. \_\_\_\_\_ OF \_\_\_\_\_  
CALCULATED BY DLP DATE 11/82  
CHECKED BY \_\_\_\_\_ DATE \_\_\_\_\_  
SCALE \_\_\_\_\_

Pier 2 - Cost

Replace damaged piles

2 - 14" precast prestressed concrete piles  
in-place \$ 3,000

New reinforced concrete cap \$ 1,750

Cut and patch deck hole \$ 568

Per repair \$ 5,318

Jacket piles -

\$132 / linear foot of jacket

10 x 132' = \$ 1320 / pile

CHILDS ENGINEERING CORPORATION  
Box 333  
MEDFIELD, MA 02052

JOB 498-81  
SHEET NO. \_\_\_\_\_ OF \_\_\_\_\_  
CALCULATED BY DLP DATE 11-82  
CHECKED BY \_\_\_\_\_ DATE \_\_\_\_\_  
SCALE \_\_\_\_\_

Bulkhead:

Clean, patch concrete - pneumatically applied.

#15/s.f. -

$$2 \text{ s.f. / L.F.} \times 600 \text{ L.F.} = 1200 \text{ s.f. @ } \#15 = \$18000$$

Gravel fill in front of wall -

#5/c.y. in-place.

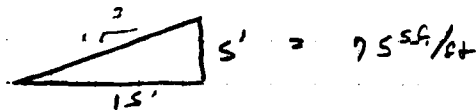

$$75 \frac{\text{sf}}{\text{ft}} \times 1800 = 135,000 \text{ c.f.} = 5000 \text{ c.y.}$$

$$\$5 \times 5000 = \$25000$$

---

$$\$43,000.00$$

CHILDS ENGINEERING CORPORATION  
Box 333  
MEDFIELD, MA 02052

JOB 498-81  
SHEET NO \_\_\_\_\_ OF \_\_\_\_\_  
CALCULATED BY DLP DATE 11/82  
CHECKED BY \_\_\_\_\_ DATE \_\_\_\_\_  
SCALE \_\_\_\_\_

Pier A

Cost estimate:

New treated pile cut-off in place  
including refastening & shimming.  
Mob-Demob -  
\$1500  
\$2500  
\$4000.00

refasten reshim pile \$500/pile  
\$100/bag 5 bags/pile = \$500/pile  
9 piles @ \$500 \$4500  
mob-demob. 500  
\$5000

CHILDS ENGINEERING CORPORATION  
Box 333  
MEDFIELD, MA 02052

49B-C-32  
SHEET NO \_\_\_\_\_  
CALCULATED BY CDS DATE 10-28-82  
CHECKED BY \_\_\_\_\_ DATE \_\_\_\_\_  
SCALE NOT TO SCALE

### ULTRASONIC STEEL THICKNESS MEASUREMENTS

FACILITY PIER 1  
STATION CELL 1 SOUTH

ORIGINAL THICKNESS: .500"

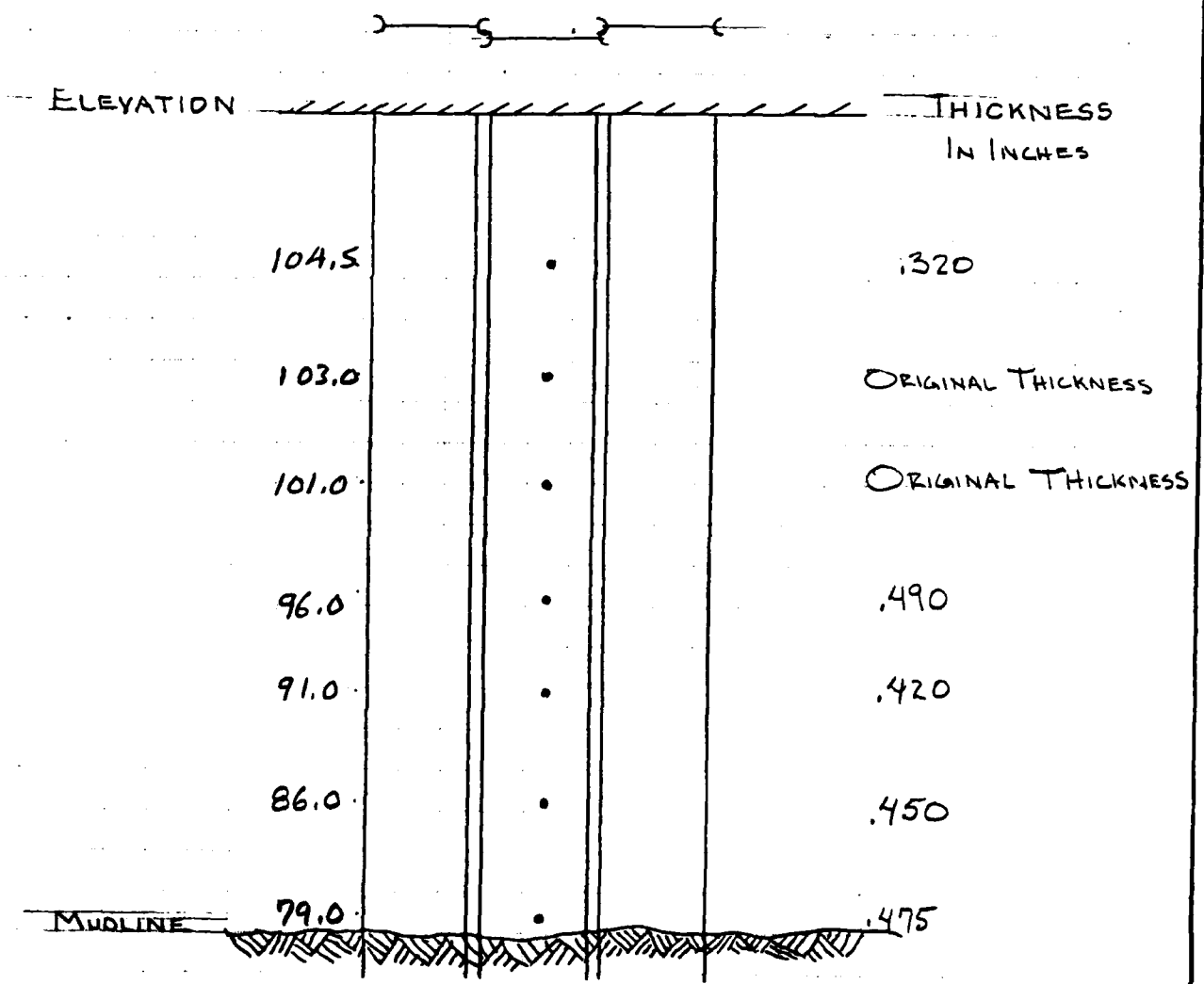

CHILDS ENGINEERING CORPORATION  
 Box 333  
 MEDFIELD, MA 02052

JOB 49B-C-82 ALAMEDA NAS  
 SHEET NO. \_\_\_\_\_ OF \_\_\_\_\_  
 CALCULATED BY CDS DATE 10/28/82  
 CHECKED BY \_\_\_\_\_ DATE \_\_\_\_\_  
 SCALE NOT TO SCALE

ULTRASONIC STEEL THICKNESS MEASUREMENTS.

FACILITY PIER 1  
 STATION CELL 6 SOUTH

ORIGINAL THICKNESS: .500"

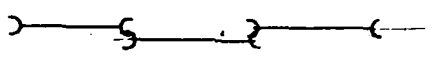

ELEVATION	THICKNESS IN INCHES
104.5	.180 - .360
102.5	ORIGINAL THICKNESS
100.5	ORIGINAL THICKNESS
95.5	.280
90.5	.465
85.5	.445
MUDLINE <u>79.0</u>	

AD-A106 322

UNDERWATER FACILITIES INSPECTIONS AND ASSESSMENTS AT  
NAVAL AIR STATION AL. (U) NAVAL FACILITIES ENGINEERING  
COMMAND WASHINGTON DC CHESAPEAKE.. SEP 82

22

UNCLASSIFIED

CHES/NAVFAC-FPO-1-82-(201

F/G 13/2

NL

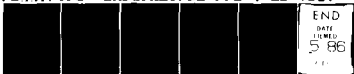

END  
DATE  
FILMED  
5 86

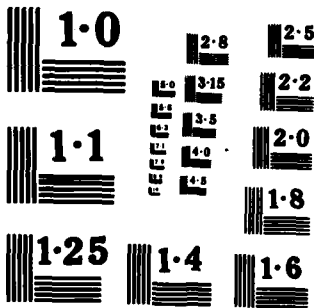

CHILDS ENGINEERING CORPORATION  
 Box 333  
 MEDFIELD, MA 02052

JOB 49B-C-82 NAS ALAMEDA  
 SHEET NO \_\_\_\_\_ OF \_\_\_\_\_  
 CALCULATED BY CDS DATE 10/28/92  
 CHECKED BY \_\_\_\_\_ DATE \_\_\_\_\_  
 SCALE NOT TO SCALE

**ULTRASONIC STEEL THICKNESS MEASUREMENTS**

FACILITY PIER 1  
 STATION CELL II SOUTH

ORIGINAL THICKNESS: .500"

ELEVATION	THICKNESS IN INCHES
104.5	.230
102.5	ORIGINAL THICKNESS
100.5	ORIGINAL THICKNESS
98.5	.395
96.5	.425
95.5	—
90.0	.485

CHILDS ENGINEERING CORPORATION  
Box 333  
MEDFIELD, MA 02052

JOB 49B-C-82 NAS ALAMEDA  
SHEET NO \_\_\_\_\_ OF \_\_\_\_\_  
CALCULATED BY CDS DATE 10/28/82  
CHECKED BY \_\_\_\_\_ DATE \_\_\_\_\_  
SCALE NOT TO SCALE

### ULTRASONIC STEEL THICKNESS MEASUREMENTS

FACILITY PIER 1  
STATION CELL 16 SOUTH

ORIGINAL THICKNESS: .500"

ELEVATION	THICKNESS IN INCHES
104.5	.490
102.5	ORIGINAL THICKNESS
100.5	ORIGINAL THICKNESS
95.5	.395
90.5	.385
82.0	ORIGINAL THICKNESS

MUDLINE

CHILDS ENGINEERING CORPORATION  
 Box 333  
 MEDFIELD, MA 02052

JOB 498-C-82 NAS ALAMEDA  
 SHEET NO \_\_\_\_\_ OF \_\_\_\_\_  
 CALCULATED BY CDS DATE 10/28/82  
 CHECKED BY \_\_\_\_\_ DATE \_\_\_\_\_  
 SCALE NOT TO SCALE

## ULTRASONIC STEEL THICKNESS MEASUREMENTS

FACILITY PIER 1  
 STATION CELL 21 SOUTH

ORIGINAL THICKNESS: .500"

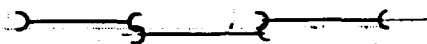

ELEVATION	THICKNESS IN INCHES
104.5	.455
104.0	.235
102.0	ORIGINAL THICKNESS
100.0	—
95.0	.410
90.0	.420
81.0	.485

MUDLINE

CHILDS ENGINEERING CORPORATION  
Box 333  
MEDFIELD, MA 02052

JCR 49B-C-82 NAS ALAMEDA  
SHEET NO \_\_\_\_\_ OF \_\_\_\_\_  
CALCULATED BY CDS DATE 10/20/82  
CHECKED BY \_\_\_\_\_ DATE \_\_\_\_\_  
SCALE NOT TO SCALE

### ULTRASONIC STEEL THICKNESS MEASUREMENTS

FACILITY PIER 1  
STATION CELL 23 SOUTH

ORIGINAL THICKNESS: .500"

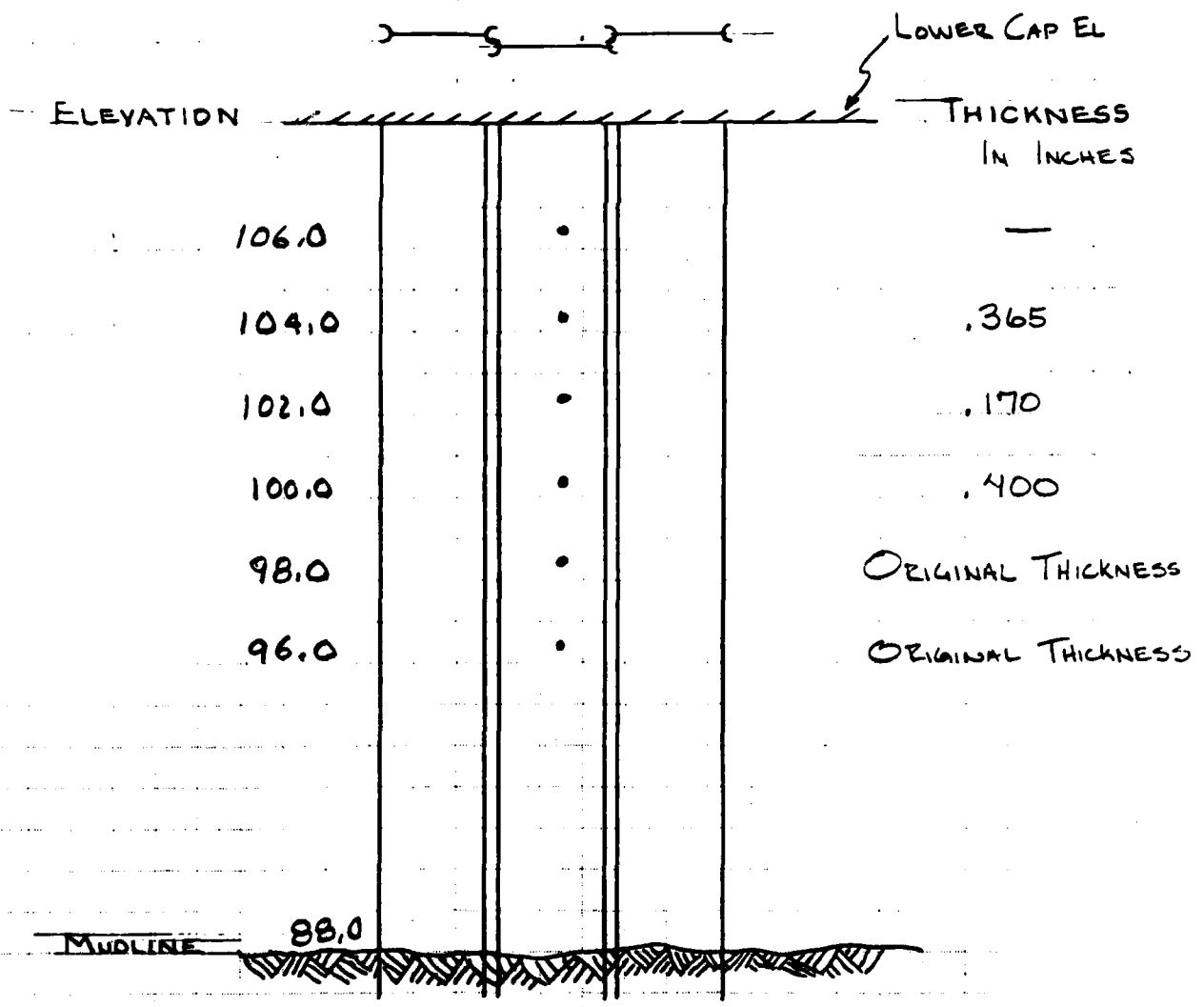

DATE  
L MED  
— 8