

MICROCOPY RESOLUTION TEST CHART
40x

12

DTNSRDC/SPD-1179-01

DAVID W. TAYLOR NAVAL SHIP RESEARCH AND DEVELOPMENT CENTER



Bethesda, Maryland 20084

AD-A166 399

DIRECTIONAL WAVE MEASUREMENTS DURING THE
HR. MS. TYDEMAN SEA TRIAL

by

Robert J. Bachman

and

Edward W. Foley

DTIC
SELECTE
APR 10 1986
S D

APPROVED FOR PUBLIC RELEASE: DISTRIBUTION UNLIMITED

DIRECTIONAL WAVE MEASUREMENTS DURING THE HR. MS. TYDEMAN SEA TRIAL

SHIP PERFORMANCE DEPARTMENT

December 1985

DTNSRDC/SPD-1179-01

FILE COPY

86 4 0 002

MAJOR DTNSRDC ORGANIZATIONAL COMPONENTS

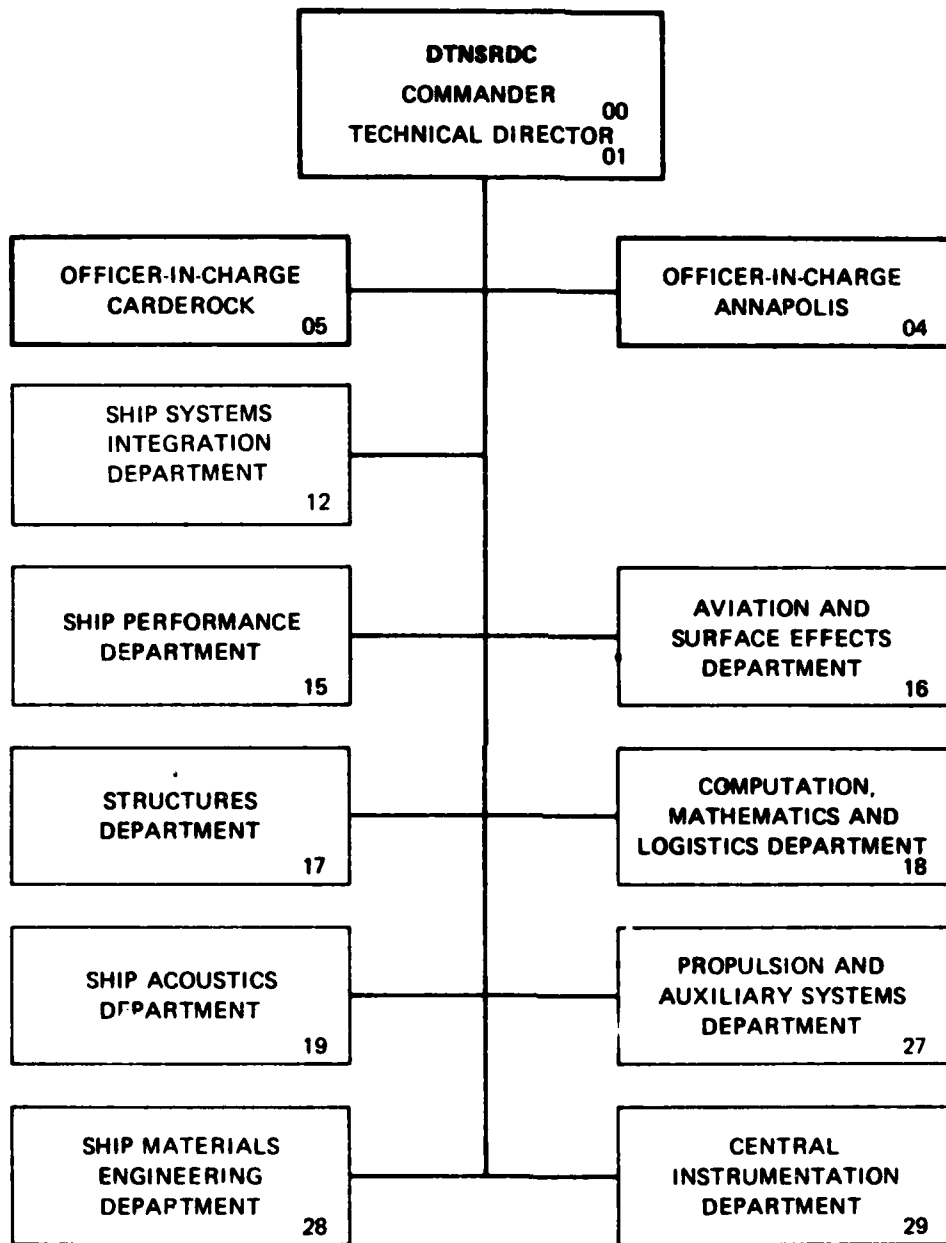

UNCLASSIFIED

SECURITY CLASSIFICATION OF THIS PAGE

REPORT DOCUMENTATION PAGE

1a REPORT SECURITY CLASSIFICATION UNCLASSIFIED			1b RESTRICTIVE MARKINGS		
2a SECURITY CLASSIFICATION AUTHORITY			3 DISTRIBUTION/AVAILABILITY OF REPORT APPROVED FOR PUBLIC RELEASE: DISTRIBUTION UNLIMITED		
2b DECLASSIFICATION/DOWNGRADING SCHEDULE			4 PERFORMING ORGANIZATION REPORT NUMBER(S) DTNSRDC/SPD-1179-01		
6a NAME OF PERFORMING ORGANIZATION David W. Taylor Naval Ship Research & Development Center			6b OFFICE SYMBOL (if applicable) 1561	5 MONITORING ORGANIZATION REPORT NUMBER(S)	
6c ADDRESS (City, State, and ZIP Code) Bethesda, Maryland 20084-5000			7a NAME OF MONITORING ORGANIZATION		
8a NAME OF FUNDING/SPONSORING ORGANIZATION Naval Sea Systems Command		8b OFFICE SYMBOL (if applicable)	9 PROCUREMENT INSTRUMENT IDENTIFICATION NUMBER		
8c ADDRESS (City, State, and ZIP Code) Washington, D.C. 20362			10 SOURCE OF FUNDING NUMBERS		
			PROGRAM ELEMENT NO 62759N	PROJECT NO	TASK NO SF 59-557
					WORK UNIT ACCESSION NO DN1780231
11 TITLE (Include Security Classification) DIRECTIONAL WAVE MEASUREMENTS DURING THE HR. MS. TYDEMAN SEA TRIAL					
12 PERSONAL AUTHOR(S) Robert J. Bachman and Edward W. Foley					
13a TYPE OF REPORT Final		13b TIME COVERED FROM TO		14 DATE OF REPORT (Year, Month, Day) 1985 December	15 PAGE COUNT 44
16 SUPPLEMENTARY NOTATION					
17 COSATI CODES			18 SUBJECT TERMS (Continue on reverse if necessary and identify by block number)		
FIELD	GROUP	SUB-GROUP			
08	03		Directional Waves		
			Wave Buoy Comparisons		
19 ABSTRACT (Continue on reverse if necessary and identify by block number) Trials were conducted in May 1982 aboard the Dutch oceanographic research ship Hr. Ms. TYDEMAN to compare the performance of three wave buoys. These were a disposable buoy designed and built by Delft University of Technology, a WAVEC buoy under development by the Datawell Corporation, and an ENDECO Corporation Wave-Track buoy owned by the David Taylor Naval Ship Research and Development Center. The disposable buoy provided energy spectra, while the other two buoys provided energy spectra and wave directionalities. The time histories of the significant wave heights and modal wave periods of the WAVEC and the Wave-Track buoys generally agree throughout the experiment. The energy spectra, mean wave directions, and spreading angles are also presented for most of the runs measured by the WAVEC and the Wave-Track buoys. The spectra of the two buoys are similar, with the WAVEC buoy showing higher peaks in a majority of cases. The mean directions basically compare well for wave frequencies above 0.11 hertz. Wave-Track mean directions below this range (Continued on reverse side)					
20 DISTRIBUTION/AVAILABILITY OF ABSTRACT <input type="checkbox"/> UNCLASSIFIED/UNLIMITED <input checked="" type="checkbox"/> SAME AS RPT <input type="checkbox"/> DTIC USERS			21 ABSTRACT SECURITY CLASSIFICATION Unclassified		
22a NAME OF RESPONSIBLE INDIVIDUAL Robert J. Bachman			22b TELEPHONE (Include Area Code) 202/227-1817	22c OFFICE SYMBOL Code 1561	

UNCLASSIFIED

SECURITY CLASSIFICATION OF THIS PAGE

Block 19 (continued)

are often too sporadic for comparison with the WAVEC directions. The spreading of the Wave-Track directional energy is greater than the spreading of the WAVEC directional energy. The observed wave directions agree more favorably with the mean directions associated with the peak frequency of the Wave-Track buoy during the first half of the experiment and with those of the WAVEC buoy during the second half of the experiment.

UNCLASSIFIED

SECURITY CLASSIFICATION OF THIS PAGE

TABLE OF CONTENTS

	Page
LIST OF FIGURES	iii
TABLE	iv
ABSTRACT	1
ADMINISTRATIVE INFORMATION	1
INTRODUCTION	1
INSTRUMENTATION	3
TRIAL DESCRIPTION	4
ANALYSIS	5
DATA PROCESSING	7
DISCUSSION	7
CONCLUDING REMARKS	12
ACKNOWLEDGMENTS	13
REFERENCES	15

LIST OF FIGURES

1 - Datawell WAVEC Buoy	17
2 - Delft Disposable Buoy	18
3 - Stabilization of Delft Buoy	19
4 - ENDECO Type 956 Wave-Track Buoy	20
5 - TYDEMAN Transit Route	21
6 - Time History of Wind Speed, Direction, Measured Wave Directions and Observed Wave Direction	22
7 - Time History of Modal Wave Period and Significant Wave Height	23
8 - Energy Spectrum, Mean Wave Direction and Spreading of Runs 3 and 4	24
9 - Energy Spectrum, Mean Wave Direction and Spreading of Runs 5 and 6	25



Availability Codes	
Dist	Avail and/or Special
A-1	

	Page
10 - Energy Spectrum, Mean Wave Direction and Spreading of Runs 7 and 8 . . .	26
11 - Energy Spectrum, Mean Wave Direction and Spreading of Runs 9 and 10 . . .	27
12 - Energy Spectrum, Mean Wave Direction and Spreading of Runs 12 and 14 . . .	28
13 - Energy Spectrum, Mean Wave Direction and Spreading of Runs 16 and 17 . . .	29
14 - Energy Spectrum, Mean Wave Direction and Spreading of Runs 19 and 20 . . .	30
15 - Energy Spectrum, Mean Wave Direction and Spreading of Runs 21 and 22 . . .	31
16 - Energy Spectrum, Mean Wave Direction and Spreading of Runs 23 and 24 . . .	32
17 - Energy Spectrum, Mean Wave Direction and Spreading of Runs 25 and 26 . . .	33
18 - Energy Spectrum, Mean Wave Direction and Spreading of Runs 27 and 28 . . .	34
19 - Energy Spectrum, Mean Wave Direction and Spreading of Runs 30 and 31 . . .	35
20 - Energy Spectrum, Mean Wave Direction and Spreading of Runs 32 and 33 . . .	36
21 - Energy Spectrum, Mean Wave Direction and Spreading of Runs 34 and 35 . . .	37
22 - Energy Spectrum, Mean Wave Direction and Spreading of Runs 36 and 38 . . .	38
23 - Energy Spectrum, Mean Wave Direction and Spreading of Run 39	39

TABLE

1 - Times and Locations of Data Collection	40
--	----

Sea tests

ABSTRACT

Trials were conducted in May 1982 aboard the Dutch oceanographic research ship Hr. Ms. TYDEMAN to compare the performance of three wave buoys. These were a disposable buoy designed and built by ~~Delft University~~ of Technology, a WAVEC buoy under development by the Datawell Corporation, and an ENDECO Corporation Wave-Track buoy owned by the David Taylor Naval Ship Research and Development Center. The disposable buoy provided energy spectra, while the other two buoys provided energy spectra and wave directionalities. ~~The~~ time histories of the significant wave heights and modal wave periods of the WAVEC and the Wave-Track buoys generally agree throughout the experiment. ~~The~~ energy spectra, mean wave directions, and spreading angles are also presented for most of the runs measured by the WAVEC and the Wave-Track buoys. The spectra of the two buoys are similar, with the WAVEC buoy showing higher peaks in a majority of cases. The mean directions basically compare well for wave frequencies above 0.11 hertz. Wave-Track mean directions below this range are often too sporadic for comparison with the WAVEC directions. The spreading of the Wave-Track directional energy is greater than the spreading of the WAVEC directional energy. The observed wave directions agree more favorably with the mean directions associated with the peak frequency of the Wave-Track buoy during the first half of the experiment and with those of the WAVEC buoy during the second half of the experiment.

Key words: Directional ocean waves. ←

ADMINISTRATIVE INFORMATION

The work reported herein was sponsored by the Naval Material Command/Naval Sea Systems Command Exploratory Development, Surface Wave Spectra for Ship Design Program (P.E. 62759N, SF 59-557). The work was carried out at David W. Taylor Naval Ship Research and Development Center (DTNSRDC) under Work Unit Numbers 1500-382, 1500-383, 1500-384, and 1500-385.

INTRODUCTION

During the spring of 1982, a joint wave buoy study was conducted with participants from the Netherlands and the United States. The scientific party consisted of members of the Delft University and the Datawell Corporation from the Netherlands and DTNSRDC from the United States. Wave and wind data, along with ship motions were measured on board the Dutch research ship Hr. Ms. TYDEMAN while transiting the eastern North Atlantic. Wave data were measured using two directional sensing wave buoys, which provided directional spectra, and an acceleration

buoy, which provided point spectra. Datawell supplied a wave slope following buoy, referred to as the WAVEC buoy, and Delft University supplied a low cost, "disposable" acceleration buoy. DTNSRDC supplied a wave orbital following buoy manufactured by ENDECO and designated as the Type 956 Wave-Track. Ship motion and wind were measured by the team from Delft University.

This wave study provided an opportunity to compare the wave height and directional measuring capabilities of the Wave-Track buoy in relation to the other buoys and the observed data. The Wave-Track approach to directional wave measurement is based on a different concept to the conventional slope following method, i.e., the determination of wave directions by sensing the wave orbital velocities. This allows the design of the buoy to be small and lightweight compared to slope following buoys. For trials work, the Navy requires a lightweight, easy-to-handle directional sensing wave buoy that provides a first order measurement of wave directionalities.

The ENDECO Wave-Track Buoy gives the U.S. Navy a tool to help validate its spectral wave model. The Spectral Ocean Wave Model (SOWM), operational since 1975 at the Fleet Numerical Oceanography Center (FNOC)^{1*} in Monterey, California, provided forecasts of wave environmental conditions at specified grid points in the Northern Hemisphere every 12 hours. The model permits the simultaneous representation of both locally generated wind seas and swell from decaying or distant storms. The wave model can also be used in a hindcast mode by using historic pressure field data to derive wind and ultimately wave data. Some of the results have been reported in References 2 to 7.

Within the past year a newer ocean wave model has been used, replacing the SOWM at FNOC. The Global Spectral Ocean Wave Model (GSOWM) provides forecasts of wave data with a finer grid spacing of 2 1/2 degrees. The new model still generates forecasts every 12 hours, but now encompasses both the Northern and Southern Hemispheres.

In addition to its use with SOWM, the directional wave sensing capability of the Wave-Track buoy allows the Navy to apply the measured directional seaway to predicted ship response amplitude operators (RAOs). The developed ship responses can then be compared to trial measurements to help validate predicted RAO values.

*A complete listing of references is given on page 15.

Some wave height spectra from the above mentioned three buoys have already been presented by Foley, et al.⁸ and Gerritsma.⁹ Foley, et al.⁸ indicated that for three different analysis techniques of data obtained from the Wave-Track buoy, the spectral shapes were quite similar, but the total energy varied. When the three different buoys were analyzed using a single technique, Gerritsma⁹ indicated that the Wave-Track buoy measured a lower significant wave height in 22 of 35 runs compared to the WAVEC buoy, the root mean square (RMS) of the differences being approximately 11 percent. This data, however, as analyzed by Delft University, did not have appropriate phase corrections applied to it. The application of the phases would tend to increase the resulting Wave-Track energy values.

INSTRUMENTATION

The instrumentation used during the TYDEMAN trial consisted of equipment supplied by Datawell Corporation, Delft University, and DTNSRDC. Each organization supplied a wave buoy, recording instrumentation, and a small computer for analysis.

The Datawell Corporation supplied their new WAVEC buoy for the trial as shown by the photograph of Figure 1. The buoy was considerably larger and heavier than the other buoys although exact dimensions and weight are not known to the authors. The accelerometer, pitch-roll sensors, batteries, instrumentation and telemetry equipment were all housed within a container approximately the size of a standard 55 gallon drum. Attached to this drum was a specially constructed flotation collar which gives the buoy hull a discus shape. This slope following discus buoy has a spherically shaped dome structure to prevent capsizing.

Delft University designed and supplied a "disposable" wave buoy for the trial. This buoy was designed to be of minimal cost and yet still be a reliable instrument for the measurement of ocean waves. The buoy is referred to as the Disposable Buoy or the Delft Buoy and is shown in Figure 2. The buoy sphere is a fiberglass construction and contains rechargeable batteries, a fixed vertical accelerometer, electronics, and an FM transmitter. The accelerometer signal is not double integrated onboard the buoy, as might be expected of a more expensive buoy. A buoy of essentially the same design is now available commercially under the trade name of "WADEL" and manufactured by the AVD Corporation in Rijswijk, Holland.

Reference 10 describes the Delft buoy and its use, sometimes as a disposable instrument, during several sea trials. A complete description of the buoy is given

in Reference 11. However, the basic hydrodynamic stabilization of the fixed vertical accelerometer can be understood from Figure 3. The rigid tripod tail of the buoy (length L_1) has a weight G attached to it by a wire rope of length L_2 . A wave induced moment M would result in a buoy tilt of β degrees. In this condition, an erecting moment of F_1 times L_1 would be obtained, where F_1 is the perpendicular component of the wire tension to the tail. During this trial, a wire length of 40 meters was used such that L_2 can be assumed to be much greater than L_1 and thus the angle α approaches zero. Therefore, the erecting moment can be expressed as

$$F_1 \cdot L_1 = G \cdot \sin\beta \cdot L_1 \quad (1)$$

This rather simple method for vertical stabilization of the accelerometer seemed to function very well with no tilting of the sensor observable.

DTNSRDC deployed an ENDECO Corporation Wave-Track Directional Buoy during the trial. This buoy is the result of development work at the University of Rhode Island as well as ENDECO Corporation and has been the subject of several papers.¹²⁻¹⁴ The Wave-Track buoy was also deployed during the ARSLOE experiment as reported in Reference 15. The configuration of the buoy is shown in Figure 4. The sphere of the buoy (fiberglass) houses the electronics, transmitter, and batteries for the buoy, while the lower pendulum assembly (PVC and stainless steel hardware) houses the pitch-roll sensors, flux gate compass, and accelerometer. The pendulum assembly acts as a moment arm to tilt the buoy in response to the orbital motion of the incident wave field. This buoy has thus been classified as an orbital following buoy. Because of its inherently stable design the Wave-Track buoy is not subject to the capsizing problems associated with the discus slope following buoys.

The signals from the buoys were recorded in analog form each using a Honeywell Model 5600 recorder. These recorders provided backup to the computer systems and digital recording of the data. Delft University and Datawell Corporation employed Hewlett-Packard microcomputer systems, while DTNSRDC used a Digital Equipment Corporation microcomputer system for the purpose of digital data collection and analysis.

TRIAL DESCRIPTION

TYDEMAN is a 90 meter open ocean research ship equipped with various cranes and winches necessary for general oceanographic research. The design of the ship

and expertise of its crew made a relatively routine procedure of launching and recovering the wave buoys. The trial consisted of several buoy launches at nine locations along a transit from Den Helder, Netherlands to Santa Cruz de Tennerife in the Canary Islands, and the transit is shown in Figure 5. The route was determined in part by daily wave forecasts received from FNOC. During the trial, the FNOC forecasts were examined approximately every 12 hours in order to identify regions of greater wave activity. When possible, the course of the ship was altered to steam towards those regions.

A typical day's operations began with an early morning launch of the three wave buoys. The ship then conducted course keeping maneuvers to evaluate the seakeeping characteristics of the ship while the buoys free floated from the site of the launch. Near midday, the ship maneuvers were temporarily halted, and the buoys located, retrieved and then relaunched. This was necessary in order to keep the three buoys in a reasonable proximity to one another since they had varying drift rates. The WAVEC buoy had by far the highest drift rate due to the large sail area of the styrofoam cap. The Wave-Track and Delft buoys stayed closer together with the Wave-Track drifting slightly more than the Delft. After collecting data during the afternoon with the ship conducting maneuvers once again, the buoys were relocated and retrieved prior to darkness. Thus, wave data were collected in a nearly continuous fashion throughout the daylight hours. During the night, the ship transited and sometimes adjusted course to encounter more severe weather as located by the wave forecasts.

ANALYSIS

The technique DTNSRDC used to analyze the data is based on the Longuet-Higgins approach of calculating the first five Fourier coefficients. The Fourier coefficients are calculated from the coincident and quadrature spectra which in turn are determined from the auto spectra of each channel and cross spectra of the three channels, i.e., heave, north-south (n-s) slope, and east-west (e-w) slope. The coincident spectrum is proportional to the product of the magnitude and cosine of the phase of the cross spectrum, while the quadrature spectrum is proportional to the product of the magnitude and sine of the phase of the cross spectrum. When two measurements are 90 degrees out of phase, such as the heave and slope of a wave slope following buoy, they can be related by the quadrature spectrum, i.e., Q_{12} .

When two measurements are in phase, such as the heave and slope of a wave orbital following buoy, they can be related by the coincident spectrum, i.e., C_{12} . Since the n-s and the e-w slopes of both the wave orbital following buoy and the wave slope following buoy are also in phase, they can be related by the coincident spectrum, i.e., C_{23} . As expressed by Ewing and Pitt¹⁶, the normalized Fourier coefficients can be determined from the following equations

$$a_0 = C_{11} \quad (2a)$$

$$a_1 = C_{12} / \sqrt{C_{11}(C_{22} + C_{33})} \quad (2b)$$

$$b_1 = C_{13} / \sqrt{C_{11}(C_{22} + C_{33})} \quad (2c)$$

$$a_2 = (C_{22} - C_{33}) / (C_{22} + C_{33}) \quad (2d)$$

$$b_2 = 2C_{23} / (C_{22} + C_{33}) \quad (2e)$$

where C_{ii} is the coincident spectrum of an auto spectrum
 C_{ij} is the coincident spectrum of a cross spectrum
 1 refers to heave
 2 refers to north-south slope
 and 3 refers to east-west slope

The first coefficient, a_0 , is the wave energy spectral density. The mean direction the waves are coming from is defined by

$$\bar{\mu} = \tan^{-1}(b_1/a_1) \quad (3)$$

The significant wave height and significant period are defined as,

$$(\bar{\epsilon}_w)_{1/3} = 4(m_0)^{1/2} \quad (4)$$

$$T_{1/3} = \frac{m_0}{m_1} \quad (5)$$

where m_n is the nth moment of the spectral density

$$m_n = \int_0^{\infty} S_n(f) f^n df \quad (6)$$

A more detailed discussion on the analysis can be found in Reference 17.

The RMS spreading angle for a narrow banded sea can be determined by:

$$\theta_p = [2 - 2(a_1^2 + b_1^2)^{1/2}]^{1/2} \quad (7)$$

DATA PROCESSING

The Wave-Track data was passed through a two hertz low pass filter and digitized at four samples per second per channel. The tape speed was set at 3-3/4 ips. This is equivalent to an actual sample rate of two hertz with a low pass filter cutoff at one hertz. The engineering units are applied to the data, while the data in the direction channels are converted from tilt angles to slopes. When necessary, the data were filtered using a two-pole high pass filter to eliminate electronic drifts or offsets. The auto and cross spectra were calculated using a Fast Fourier Transformation (FFT). The data runs were divided into segments, each of a size based on the power of two. A cosine window was applied to each segment and the segments are overlapped by 50 percent.

The real and the imaginary parts of the cross spectra of each of the three channels were calculated to give the coincident and the quadrature spectra. From these, the Fourier coefficients were calculated, along with the directions, periods, and energies.

Typical lengths of a run are 1728 and 1600 seconds with the number of degrees of freedom of 51 and 47, respectively.

DISCUSSION

The data presented here represent two different approaches to measuring waves and their directions from a ship launched buoy. Delft University analyzed the WAVEC data and reported them in Reference 9. DTNSRDC analyzed the Wave-Track data.

The displayed results for a comparison of the two buoys include time histories of significant wave height, modal wave period, and mean wave directions. In the

graph of the time histories, the mean wave direction is defined by the frequency band containing the greatest energy. Also included, are energy spectral densities, mean wave directions, and RMS spreading angles measured by both buoys for most of the runs.

The bulk of the runs were made between 14 May and 18 May 1982, with only one run each made on the 17th, 19th, 20th, and 21st. The date, time, and location for each run can be found in Table 1.

The relationship between the wind speed and direction and the significant wave height, modal wave period and mean wave directions can be seen in Figures 6 and 7. Continuous time histories are displayed, but not every run was plotted. The runs not included can be found in Table 1.

The energy densities, mean wave directions, and spreading angles for the two buoys are presented in Figures 8 through 23. Tables of values for these three categories from Delft University were not available to the authors, so the graphic results were used. Scales were matched and the results of the Wave-Track buoy data were overlaid on the WAVEC buoy data. The frequency range used in the DTNSRDC analysis is 0.047 hertz to 0.30 hertz. The Dutch analysis, performed by the Department of Hydro-Instrumentation (DHI) of the Ministry of Public Works in the Netherlands, uses a range of 0.05 to 0.50 hertz. The displayed frequency range has been limited to 0.4 hertz.

On the 14th of May, the significant wave height started out as measured at 1.5 meters. It slowly decreased by the last measurement of the day in accordance with a generally decreasing wind speed coming from a steady direction of 170 degrees. The modal wave period remained fairly steady at about seven seconds.

On the 15th, the wind was fairly steady, still blowing in from 160 to 170 degrees. The wind speed remained fairly strong in the neighborhood of 12 meters per second until shortly after 1800 GMT, when the wind dropped off and the direction shifted 90 degrees to the west. The significant wave height increased steadily in accordance with the increased wind speed and steady direction. The modal period started a little lower than it had ended on the 14th, but increased to and hovered around eight seconds. This also is as expected with the stronger wind than the previous day, for a steady direction. The measurements were made in the same general area on the 14th and the 15th, as seen in Figure 5.

On the 16th of May, the ship was west of the previous area (see Figure 5). During the measurements, the wind direction slowly shifted westerly to 210 degrees,

as the wind speed decreased. At the start of measurements on this day, the significant wave height is about half a meter less than that ending the previous day and the modal wave period is one to two seconds longer. The lower wave heights and longer periods indicate a decaying swell condition and is born out by the lower measured wind speed and change in direction. This shift into the swell range can also be seen in the spectra of runs 26 through 28 (Figures 17 and 18).

A single wind measurement on the 17th indicated a low speed and a direction out of 300 degrees. On this day, a maximum modal period was reached for each buoy and a local minimum significant wave height was measured.

The 18th was the last day that several measurements were recorded in succession. After an initial drop in wind speed, the speed increased to a maximum during run 35, before dropping off. During this time, the wind shifted from about 150 to 215 degrees. The significant wave height measurement slightly increased and decreased with the wind speed, while the modal wave period decreased. This indicates an increase in wind wave energy accompanying a slowly decaying swell.

The last three runs were made on separate days at different locations. Throughout the trial, the total energies measured by both buoys are very close, as indicated by the significant wave heights. The mean and RMS values of the percent differences of the two buoys are 0.32 percent and 6.7 percent, respectively. The modal wave periods are also quite close, with a couple of exceptions, until the end of the 15th of May. However, from the 16th until the 21st, the WAVEC buoy measured a larger modal period than the Wave-Track buoy. The mean and RMS values of the percent differences are 4.5 percent and 7.0 percent, respectively.

As mentioned earlier, the wind direction is steady, around 170 degrees, from Run 3 to Run 24. The observed wave directions on the 14th are coming from 200 degrees. On the 15th, the observed wave direction is more closely in line with the measured wind direction. The directions differ by about 20 degrees near the beginning of the day and then close to the same direction towards the end of the day before the wind shifts direction. On the 16th, at location four, the observed wave direction is back to 200 degrees. On the 18th, at location six, the direction that the waves were observed to be coming from was 330 degrees.

The direction that the waves were observed to be coming from agreed more closely with the mean direction of the dominant frequency for the Wave-Track near the beginning of the trial and more closely with the WAVEC toward the end of the

trial.* On the 14th the observed wave direction agreed quite well with the mean wave direction of the dominant frequency as measured by the Wave-Track. On the 15th, the Wave-Track buoy's indicated mean direction of the dominant frequency continued to vary about the mean value of 200 degrees, while the observed direction shifted to 165 to 180 degrees. The mean wave direction of the dominant frequency for the Wave-Track buoy on the 18th, varied significantly from run to run. While recording the data for Run 35, it was noticed that the signals from the direction channels had drifted out of the linear recording range of the analog tape recorder. The direction channels coming out of the receiver were then zeroed, but a few previous runs may also have been affected.

The directions measured by the WAVEC and Wave-Track buoys differ throughout the trial. However, shifts of the mean wave directions of the dominant frequency between the two buoys generally agree in time and in the direction of the shift. This may indicate a relative offset between the two buoys' magnetic recordings or coordinate resolution.

The energy densities, as measured by both buoys, agree well, with a few minor exceptions. The spectral shapes are similar, but in several cases the density peaks of the WAVEC data are noticeably greater than the Wave-Track data. The data analyzed by DHI produced a greater frequency resolution than for the Wave-Track buoy data analyzed by DTNSRDC. The data from the WAVEC buoy shows higher, sharper peaks while the Wave-Track buoy data shows broader peaks. When two or more sharp peaks close together are produced by the analysis with greater resolution, the other analysis may combine them into one or two shorter broad peaks. Overall the total energy measured by both buoys is about the same for each run.

As mentioned earlier, the data segments in the DTNSRDC analysis are overlapped by 50 percent to smooth the results. The DHI analysis averages the spectral densities in 0.05 hertz bandwidth for each frequency center. Confidence limits are generally narrower when less resolution is required, given similar data lengths and sample rates.

The mean wave directions between the two buoys generally agree for frequencies above 0.11 hertz. A correction for the magnetic declination of 13 degrees west has been applied to the mean directions of the Wave-Track buoy data. This may account

*The direction of the dominant frequency is likely to be the direction most easily observed.

for some of the differences at the frequencies above 0.11 hertz. The Wave-Track results show a problem in defining directions in the lower frequency range. The extent of the frequency range for this problem seems to vary from run to run. The authors believe this is due to the hydrodynamic phase lag reflected primarily in the tilt channels. This lag may be greater for the longer waves that have a smaller orbital differential over the depth of the buoy than for shorter waves.

The spreading angles of the directional waves for the buoys can be seen in the lower graph of these figures. The spreading for the Wave-Track buoy data is consistently high in the lower frequency range, including the peak frequency at times. The spreading then drops to a lower level, still above that for the WAVEC data, in the middle frequencies. Finally, the spreading increases in the upper frequencies. A reasonable amount of spreading occurs in a range around the peak frequency for the WAVEC buoy data. Different spreading functions were used to calculate WAVEC and Wave-Track spreading angles.

The high level of spreading in the lower frequencies of the Wave-Track data may be due to the buoy's response to non-unidirectional orbital velocities in the long waves. Forrestal, et al.¹⁸ noted a complicated flow field in a large wave during Hurricane Delia. Three current meters were strung in the water column. The upper current meter measured the greatest horizontal velocities to be in the east-west direction; however, the velocities in the north-south direction were not negligible. The velocities can flow in a horizontally elliptical manner, and so the corresponding movement of the buoy stem can be in an elliptical manner, rather than linearly unidirectional.

This trial provided two opportunities to measure changing sea conditions over periods of several hours. In the first case, for Runs 10-25, wave data were measured from 0820 to 1843 on 15 May 1982. Middle frequency waves were coming out of the west (250-270 degrees) throughout the day, while some higher frequency wind driven waves were coming from the south (180-190 degrees). As the day progressed, the energy in the mid frequencies generally increased, with some fluctuations, until the last run. The energy in the waves that were closely aligned with the wind, i.e., south, continued to increase, with a corresponding increase in period. This can also be seen in the directions, as the ramp between the west and the south shifts to the left and becomes less steep. This is more clearly seen in the mean directions of WAVEC data than the Wave-Track data.

In the second case, a distinct development of bimodal seas can be seen. This occurred for Runs 31 to 36 from 0755 to 1340 on 18 May 1982. A generally decaying swell came from north-northwest (330-350 degrees). Over the same period of time, wind driven waves grew as they came from the south (180 degrees). The energy in the wind waves continued to grow and the period increased, until they ultimately approached and surpassed the swell energy in Run 36. The increasing period of the wind waves can also be seen in the graphs of mean directions, as the waves from the south begin to shift to the middle frequency range.

CONCLUDING REMARKS

Throughout the trial the wave measurements of the WAVEC and Wave-Track buoys agree in energy and modal period. There is a slightly greater difference between the modal wave periods than the significant wave heights, as measured by the two buoys. The measurements of the mean wave direction, associated with the modal period, were fairly consistent between the two buoys. However, there was an offset between the two, possibly due to magnetic influences or difficulties in an electronic coordinate resolution. The spectral densities, mean directions, and spreading angles are also presented for the two directional sensing wave buoys for most of the runs. The spectral density distributions of the two buoys agreed well in most cases. The agreement was not as clear, however, for the mean directions. The middle and upper frequency directions generally agreed, but the lower frequency directions measured by the Wave-Track buoy changed too much. The spreading of wave energy, as measured by the WAVEC buoy, was less than that for the Wave-Track buoy. This may be due in part to a side effect orbital wave velocities have on the submerged stem of the Wave-Track buoy.

Two cases of changing wave conditions were also measured. In one case, two growing wave systems from different directions combined to a common frequency range. The system aligned with the wind grew more quickly. In the other case, a distinct bimodal wave system was evident. The swell from one direction slowly degraded, while the wind driven sea from another direction increased in energy and period.

While the Delft buoy was also used to gather wave data, the results are not included here. The authors did not have access to the raw data, and the results available were calculated using a different method than for the results presented here for the other two buoys.

Another comparison of directional wave measuring systems is scheduled to take place during a sea trial in March 1987. A multinational effort will be carried out under the auspices of Research Study Group (RSG)1, Full Scale Wave Measurements, chaired by the U.S.A., under Special Group of Experts on Hydrodynamics (AC/243 (Hydro)). The Dutch research ship TYDEMAN and the Canadian research ship QUEST will be used as launching platforms. This upcoming trial will bring together an interesting variety of in-situ directional wave measurement systems, including buoys and possibly shipboard radar.

A comparison of SOWM forecasts and buoy measurements during the TYDEMAN trial is the subject of a future publication. Also included will be comparisons of SOWM forecasts and wave measurements conducted during other sea trials.

ACKNOWLEDGMENTS

The kind cooperation of the Royal Netherlands Navy, Exchange Agreement No. MWDDEA N-65-TN-4803, allowed this sea trial to be carried out. Dr. ir. J.M. Dirkzwager of the Ministry of Defence is gratefully acknowledged for his coordination in arranging the trial. The Delft University team headed by Prof. i.r. J. Gerritsma contributed greatly to the technical success of the trial. The assistance of Messrs. M. Buitenhek and J. Ooms is greatly appreciated as is the assistance of Mr. Gerritsen of Datawell. The officers and crew of the TYDEMAN, under the able leadership of CAPT A.P.H.M. Lempers, are gratefully acknowledged, for their assistance throughout the trial. The coordination of the American efforts by Ms. S.L. Bales of DTNSRDC is greatly appreciated.

The wave forecasts radioed by FNOG were quite helpful in planning the ship's route and the efforts of LCDR Mass are particularly appreciated. The assistance by Ms. C. Bennet and ENS's G. Hobson and A. Meurer of DTNSRDC has been very helpful.

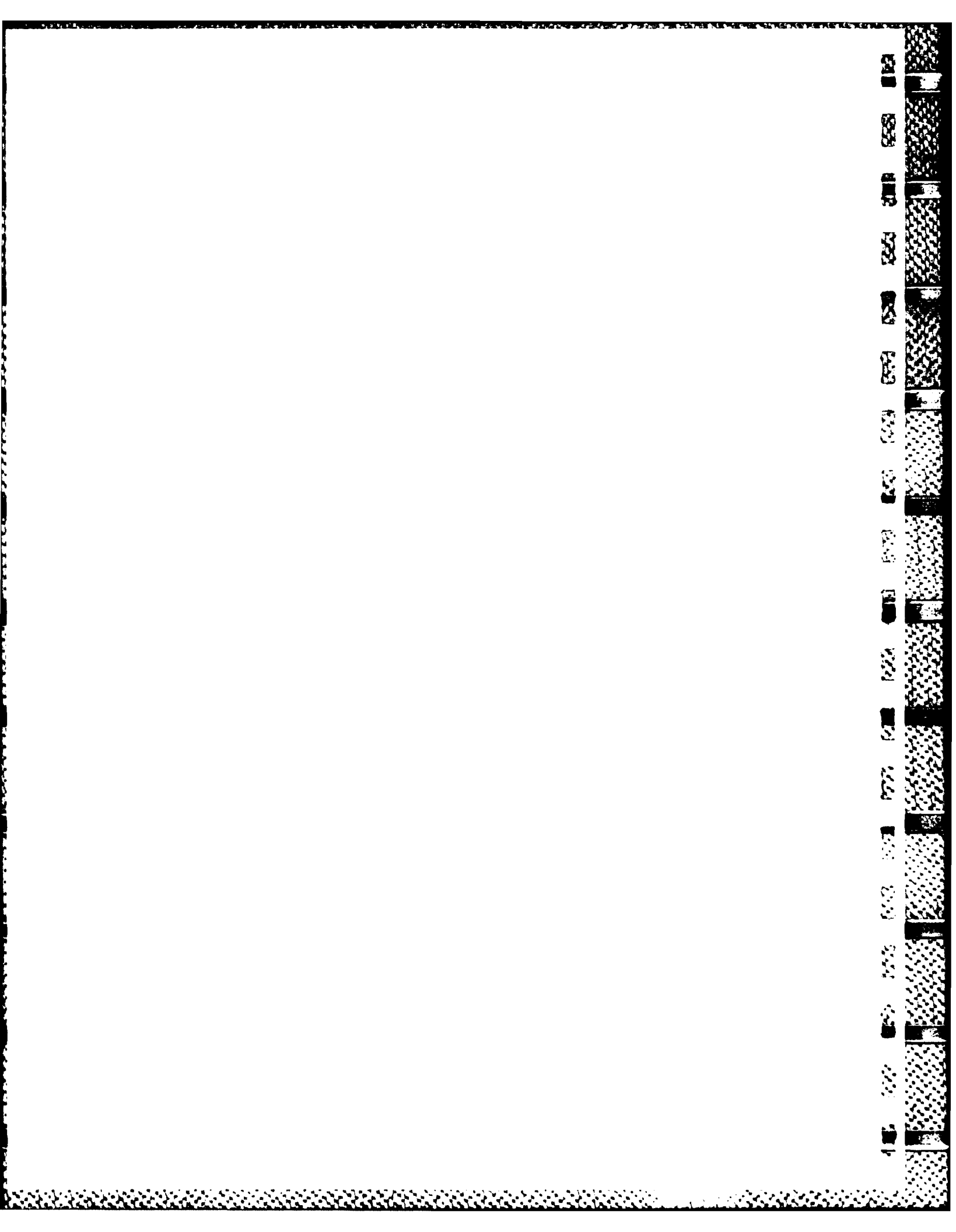

REFERENCES

1. Lazanoff, S.M. and N.M. Stevenson, "An Evaluation of a Hemispheric Operational Wave Spectral Model," FNWC Technical Note 75-3 (Jul 1975).
2. Cummins, W.E. and S.L. Bales, "Extreme Value and Rare Occurrence Wave Statistics for Northern Hemisphere Shipping Lanes," Proceedings of the Society of Naval Architects and Marine Engineers STAR Symposium (Jun 1980).
3. Bales, S.L., W.T. Lee and J.M. Voelker, "Standardized Wave and Wind Environments for NATO Operational Areas," Report DTNSRDC/SPD-0919-01 (Jul 1981).
4. Cummins, W.E., S.L. Bales and D.M. Gentile, "Hindcasting Waves for Engineering Applications," Proceedings of the International Symposium on Hydrodynamics in Ocean Engineering, The Norwegian Institute of Technology (Aug 1981).
5. Bales, S.L., W.E. Cummins and E.N. Comstock, "Potential Impact of Twenty Year Hindcast Wind and Wave Climatology on ship Design," Marine Technology, Vol. 19, No. 2 (Apr 1982).
6. Bales, S.L., "Designing Ships to the Natural Environment," Naval Engineering Journal, Vol. 95, No. 2 (Mar 1983).
7. "U.S. Navy Hindcast Spectral Ocean Wave Model Climatic Atlas: North Atlantic Ocean," prepared by Naval Oceanography Command Detachment, Asheville, North Carolina (Oct 1983).
8. Foley, E.W., R.J. Bachman and S.L. Bales, "Open Ocean Wave Buoy Comparisons in the North Atlantic," Proceedings 1983 Symposium on Buoy Technology (Apr 1983).
9. Gerritsma, J., "Wave and Ship Motion Measurements Hr. Ms. TYDEMAN Trials 1982," Delft University of Technology, Report No. 593 (Jul 1983).
10. Gerritsma, J., "Results of Recent Full Scale Seakeeping Trials," Technische Hogeschool Delft, Laboratorium Voor Scheepshydronechanica, Report No. 495 (Mar 1980).
11. Buitenhek, M. and J. Ooms, "An Updated Design of a Disposable Wave Buoy," Technische Hogeschool Delft, Report No. 463 (May 1978).
12. Middleton, F.H., L.R. LeBlanc and M. Czarnecki, "Spectral Turning and Calibration of a Wave Follower Buoy," Eighth Annual Offshore Technology Conference, Paper No. OTC 2597 (May 1976).

13. Middleton, F.H., L.R. LeBlanc and W. Sternberger, "Wave Direction Measurement by a Single Wave Follower Buoy," Tenth Annual Offshore Technology Conference, paper No. OTC 3180 (May 1978).
14. Brainard, E.C., "Wave Orbital Following Buoy," Paper presented at Marine Technology '80 Conference (not in the transactions) (Oct 1980).
15. LeBlanc, L.R. and F.H. Middleton, "Storm Directional Wave Spectra Measured with a Single Buoy," Oceans '82 Conference (Sep 1982).
16. Ewing, J.A. and E.G. Pitt, "Measurements of the Directional Wave Spectrum off South List," Conference on Wave and Wind Directionality: Applications to the Design of Structures, Paris (1982).
17. Lai, R.J. and R.J. Bachman, "Directional Wave Measurement and Analysis," Report DTNSRDC/SPD-1167-01 (Sep 1985).
18. Forristall, G.Z. et al., "The Directional Spectra and Kinematics of Surface Gravity Waves in Tropical Storm Delia," Journal of Physical Oceanography, Vol. 8, No. 5 (Sep 1978).



Figure 1 - Outwell Bay 2005

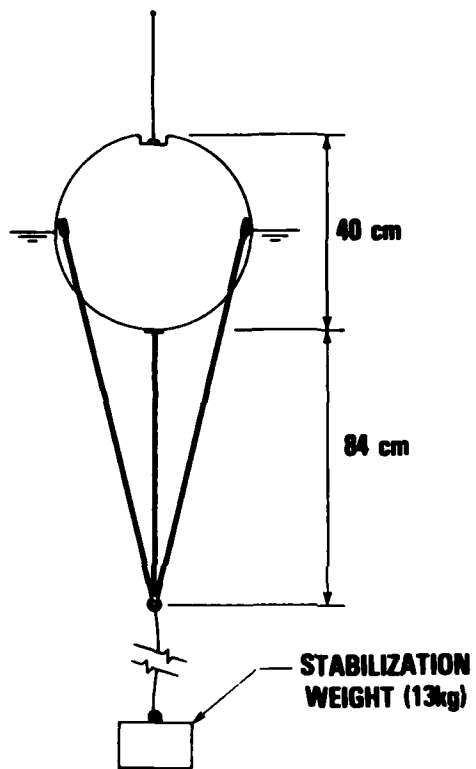

Figure 2 - Delft Disposable Buoy

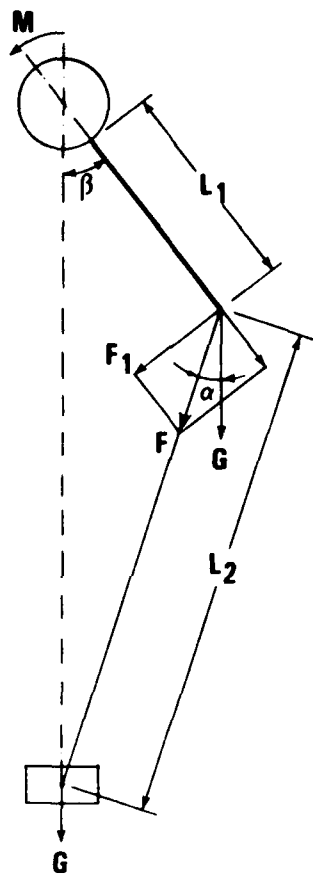

Figure 3 - Stabilization of Delft Buoy

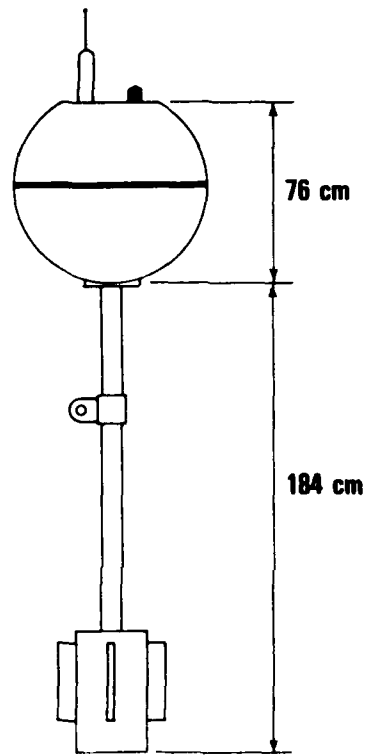

Figure 4 - ENDECO Type 956 Wave-Track Buoy

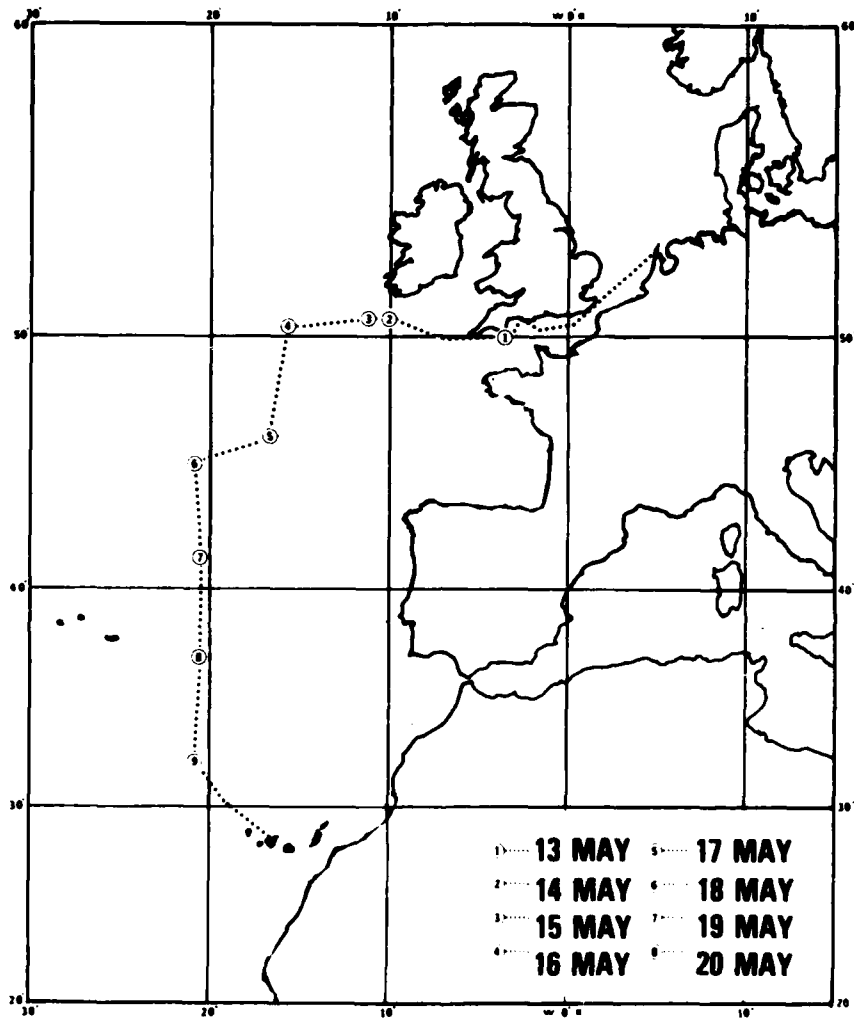

Figure 5 - TYDEMAN Transit Route

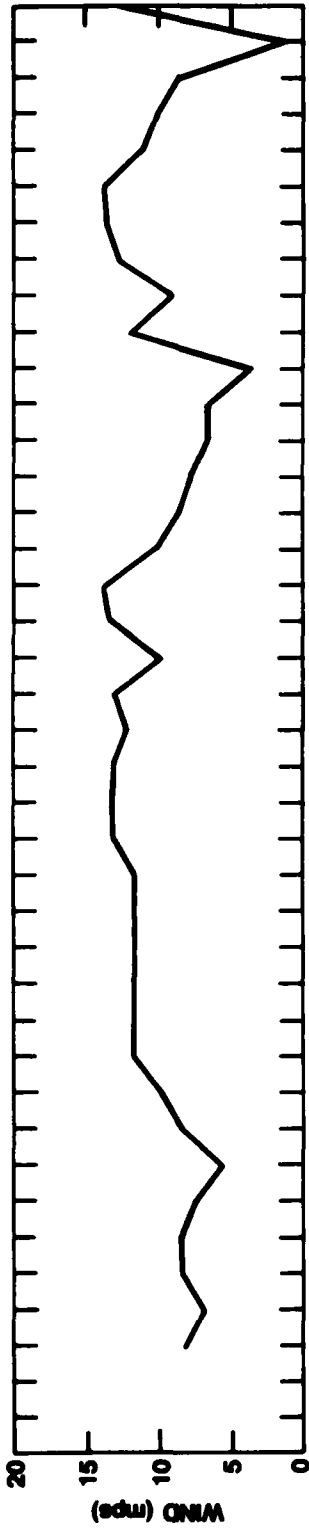

Figure 6a

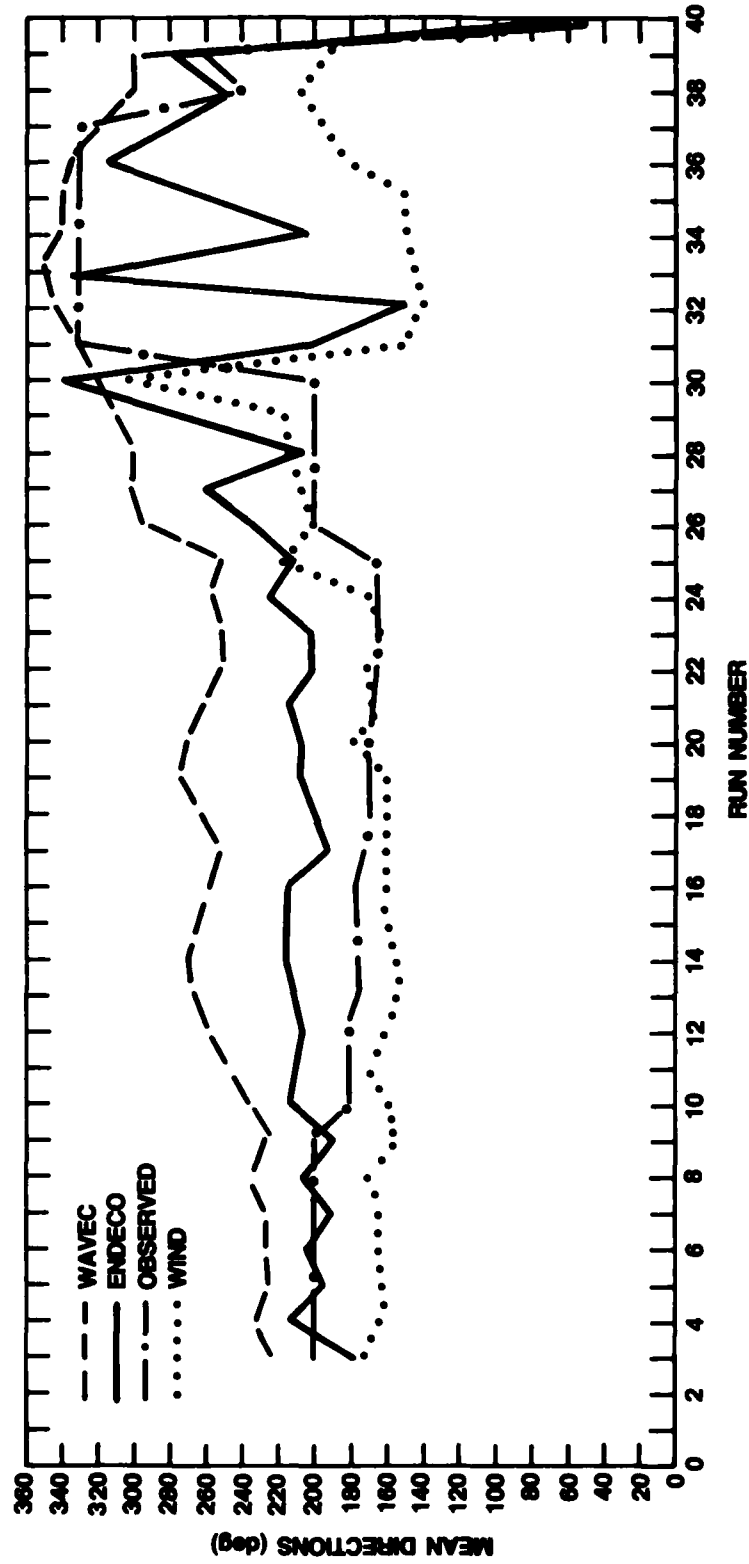

Figure 6b

Figure 6 - Time History of Wind Speed, Direction, Measured Wave Directions and Observed Wave Direction

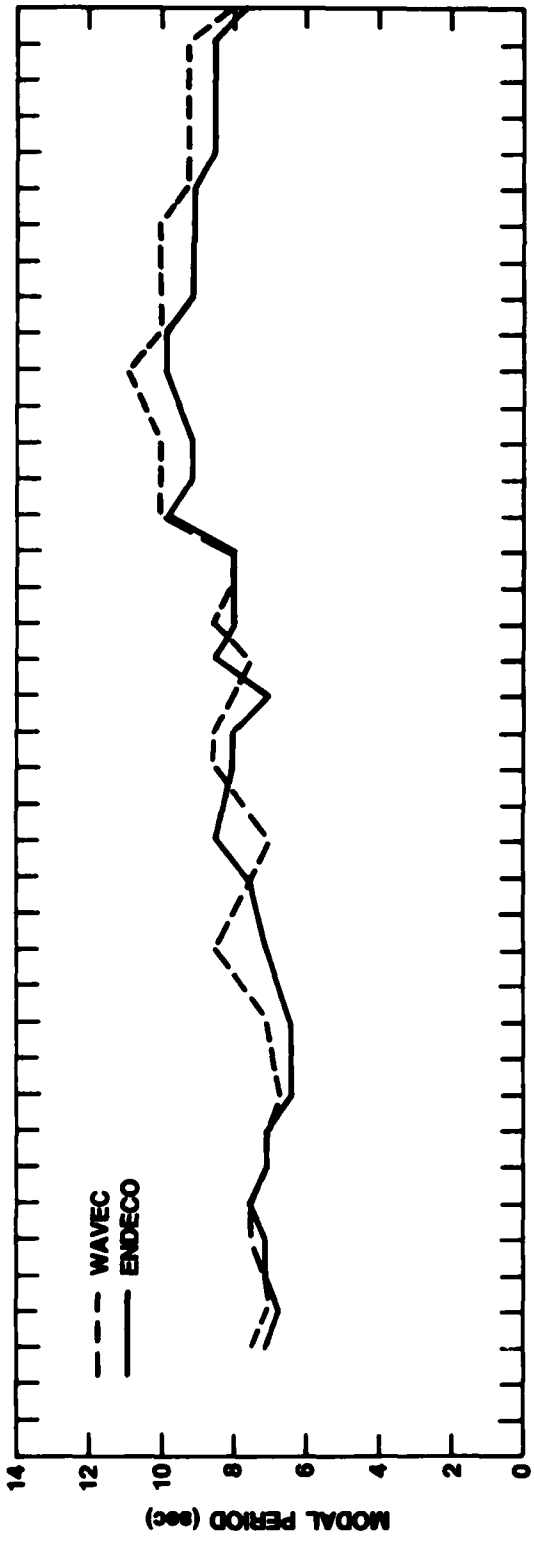

Figure 7a

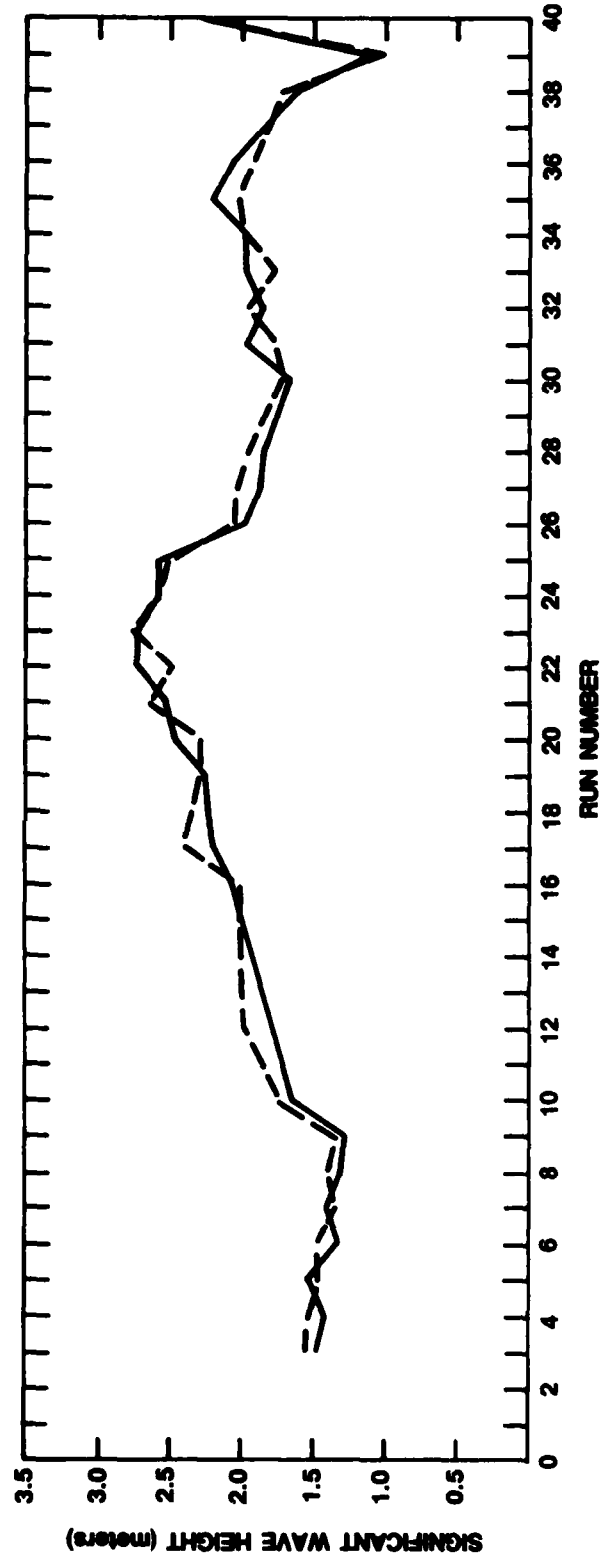

Figure 7b

Figure 7 - Time History of Modal Wave Period and Significant Wave Height

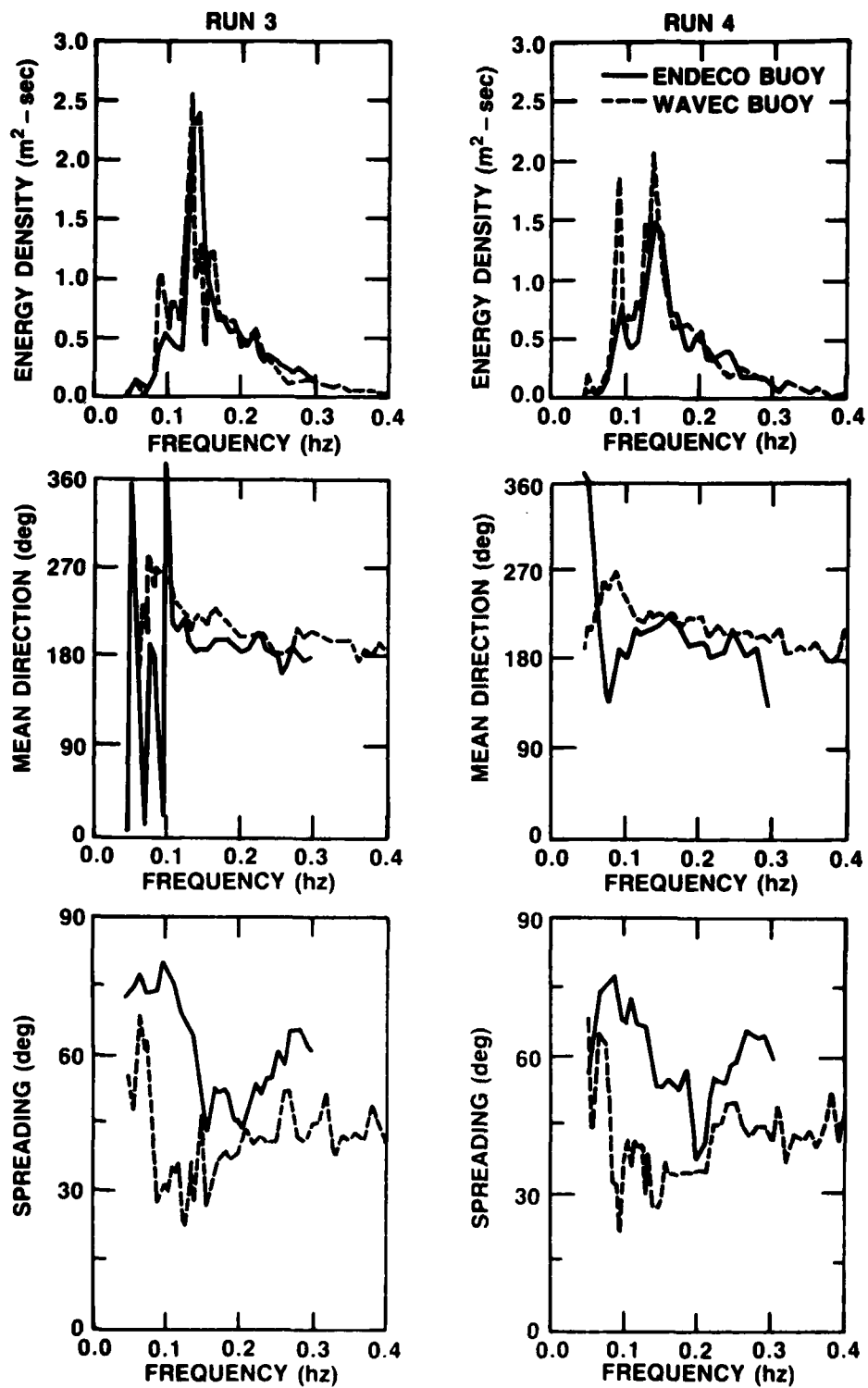

Figure 8 - Energy Densities, Mean Directions, and Spreading for Runs 3 and 4

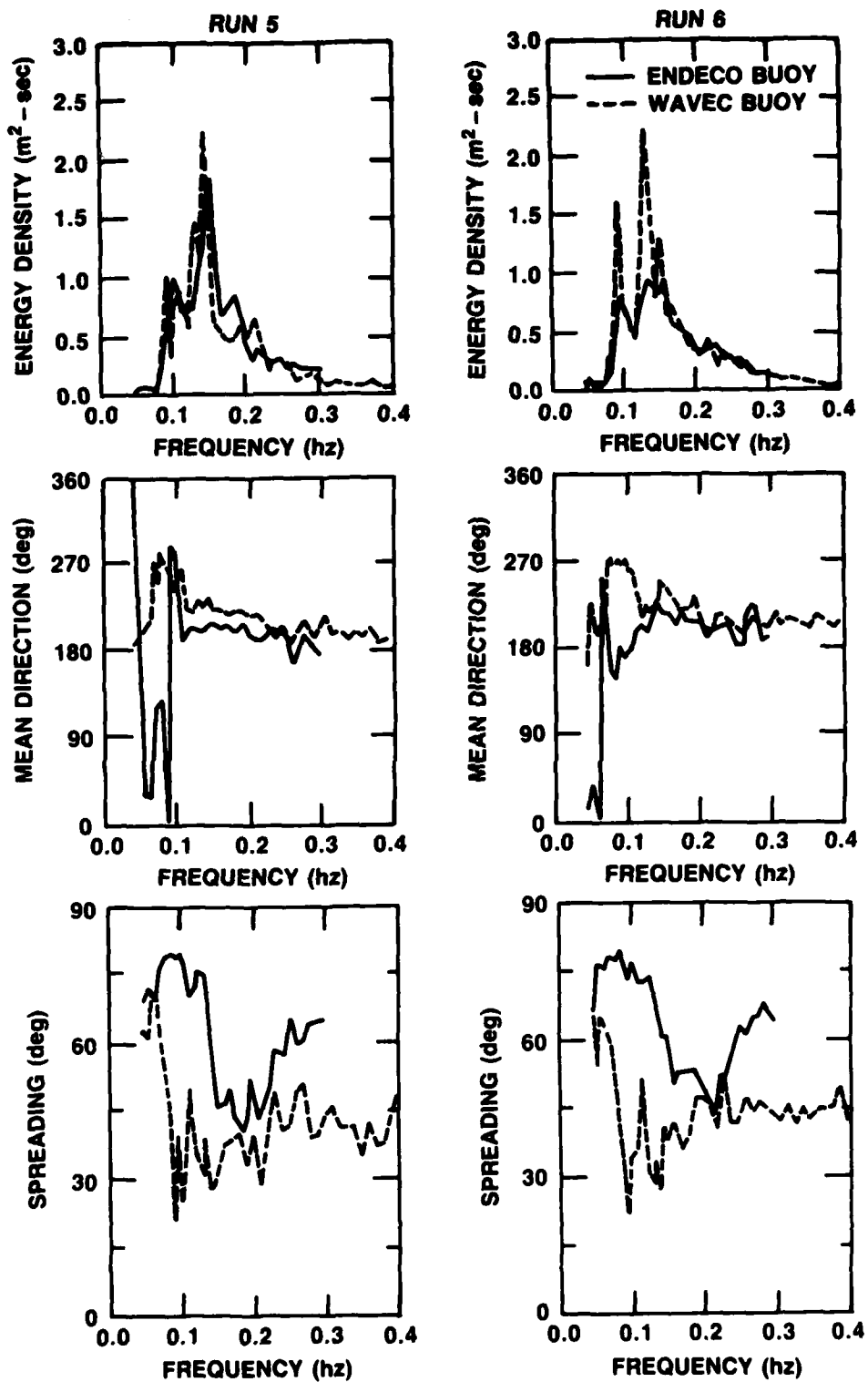

Figure 9 - Energy Densities, Mean Directions, and Spreading for Runs 5 and 6

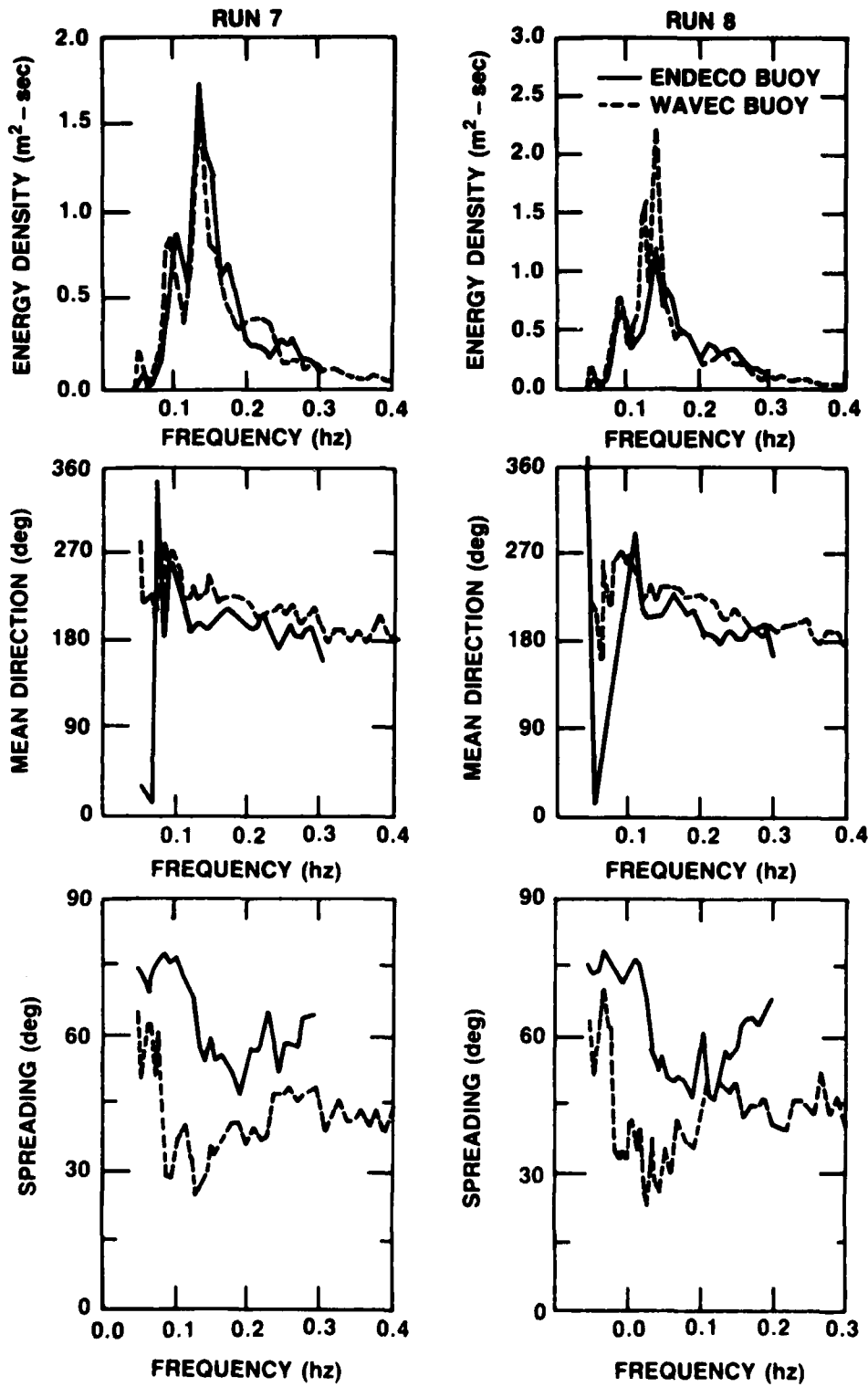

Figure 10 - Energy Densities, Mean Directions, and Spreading for Runs 7 and 8

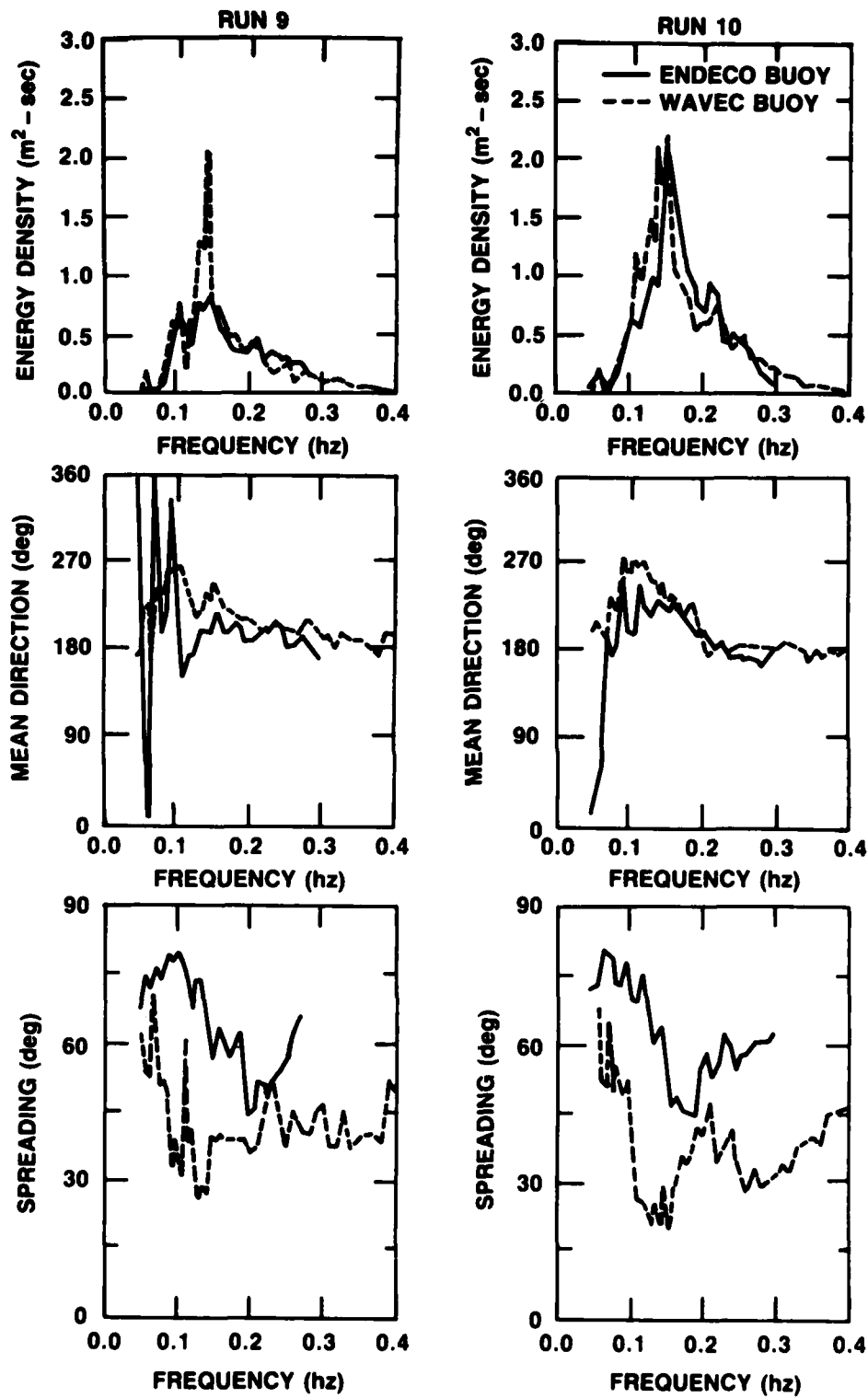

Figure 11 - Energy Densities, Mean Directions, and Spreading for Runs 9 and 10

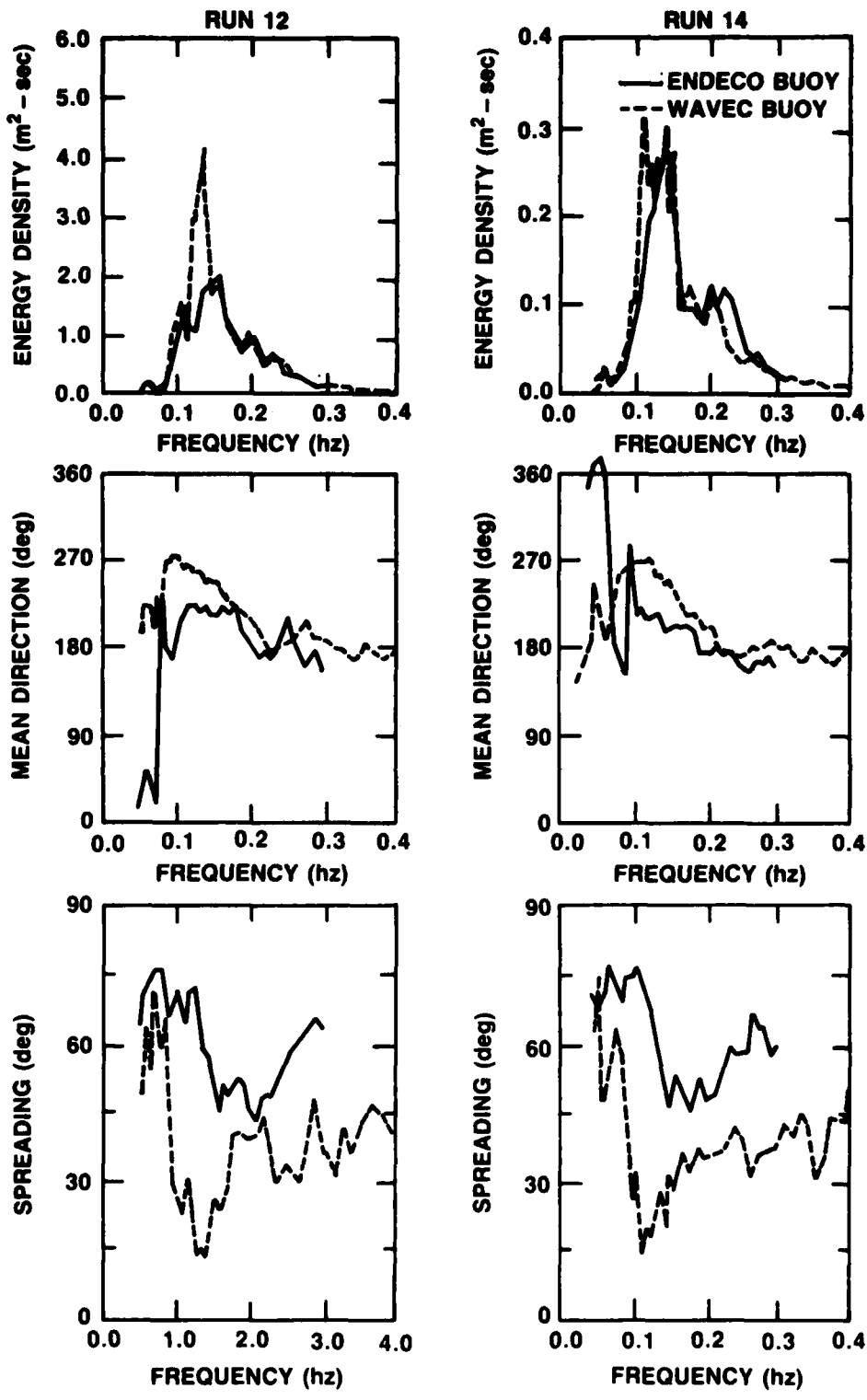

Figure 12 - Energy Densities, Mean Directions, and Spreading for Runs 12 and 14

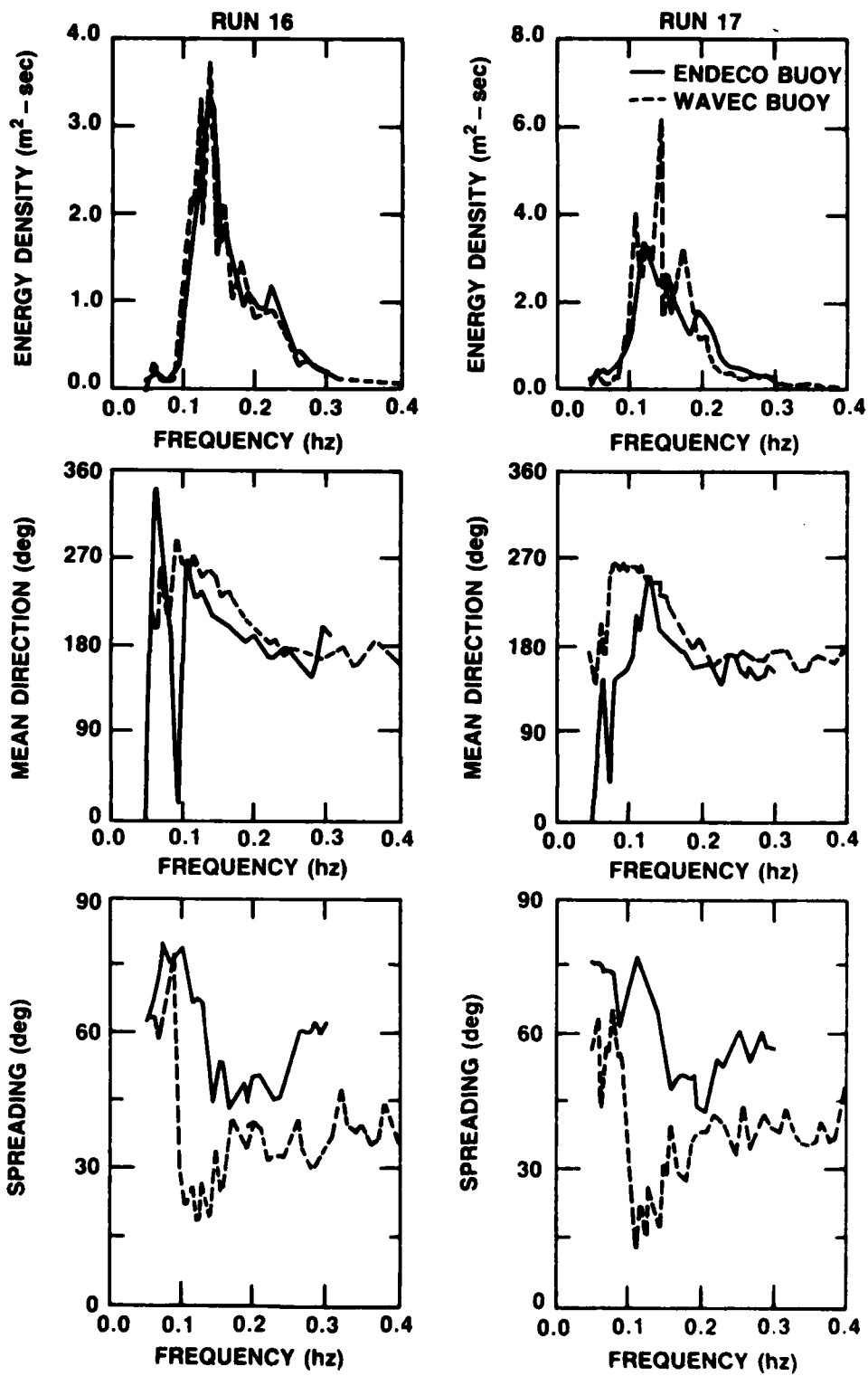

Figure 13 - Energy Densities, Mean Directions, and Spreading for Runs 16 and 17

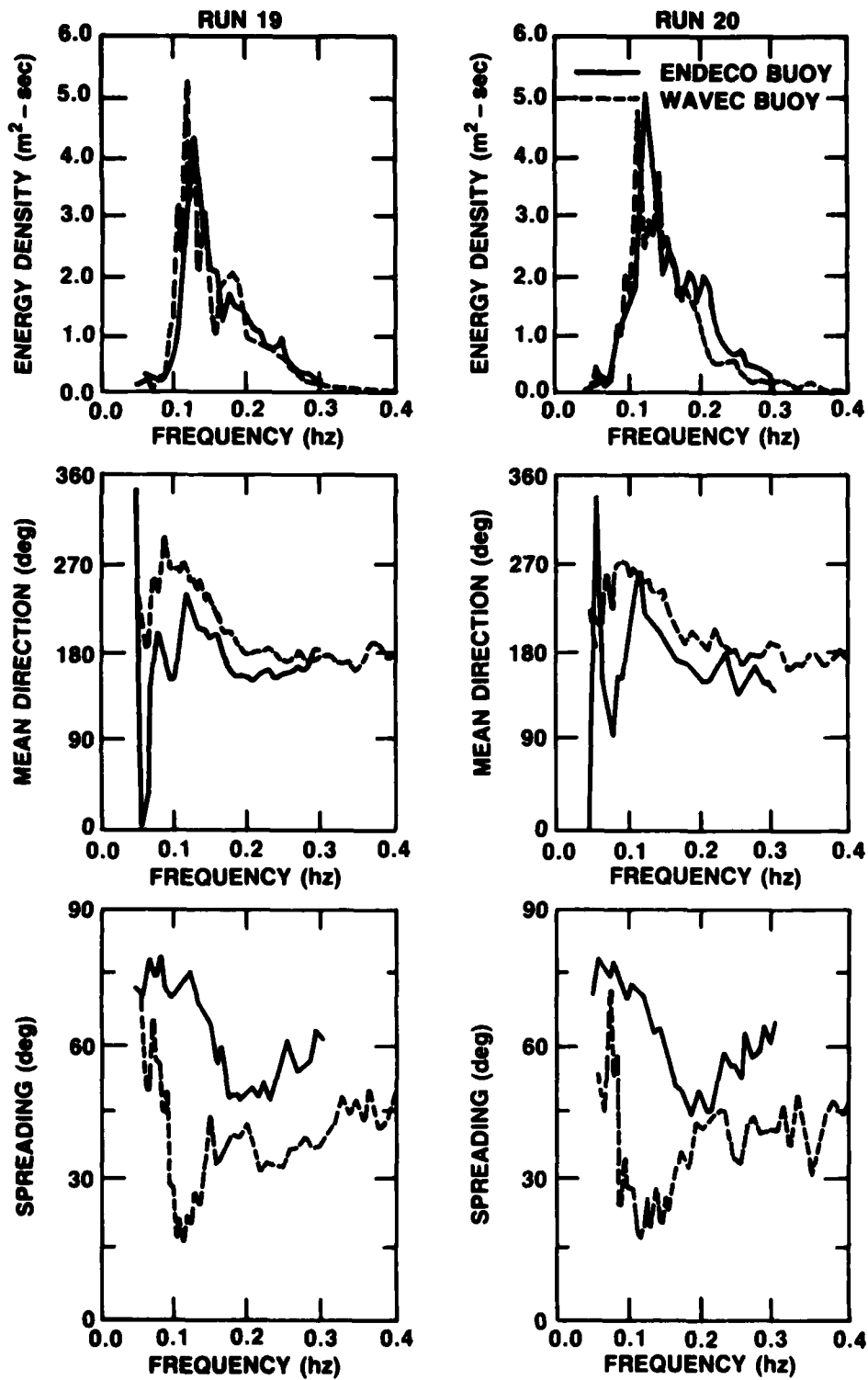

Figure 14 - Energy Densities, Mean Directions, and Spreading for Runs 19 and 20

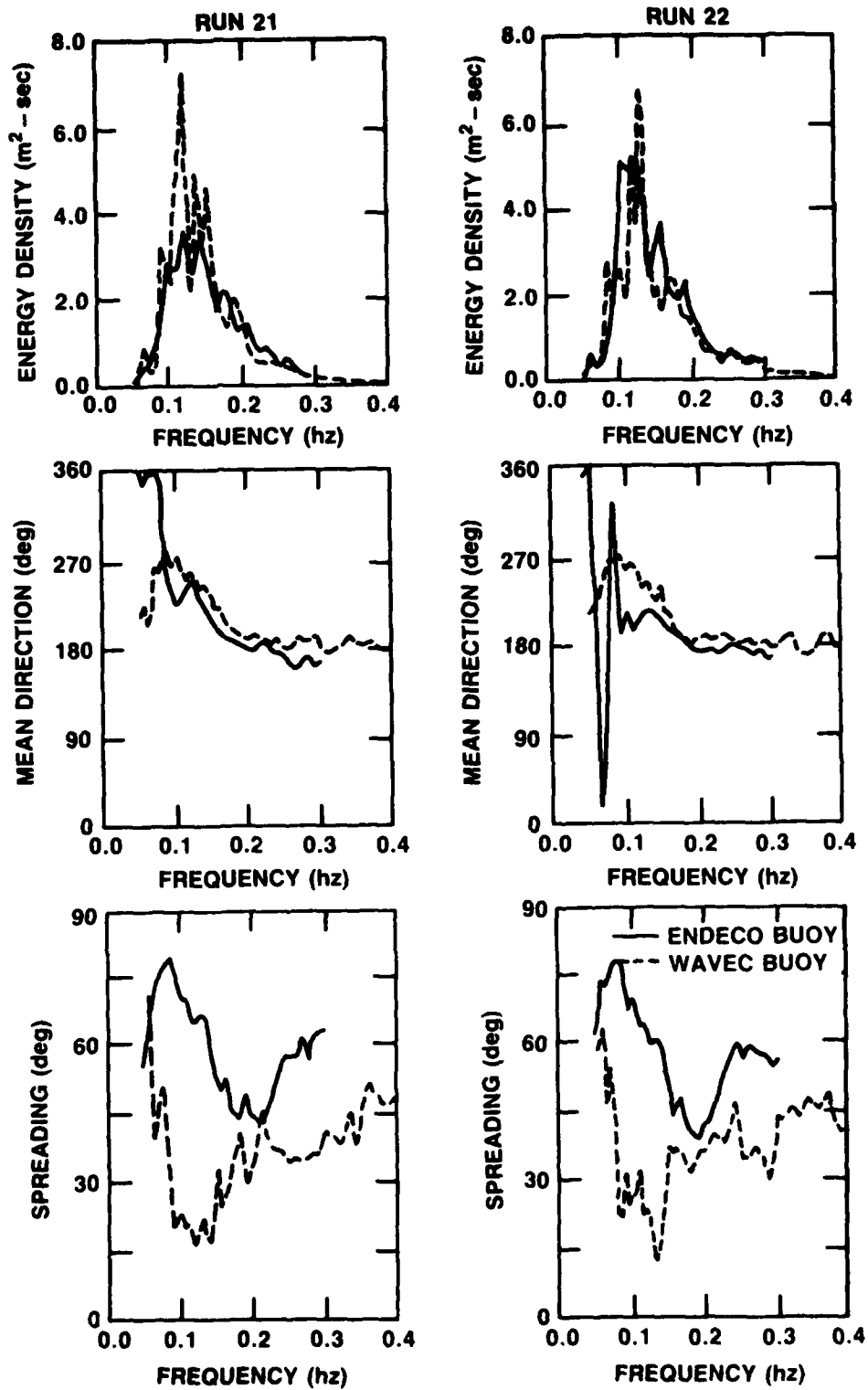

Figure 15 - Energy Densities, Mean Directions, and Spreading for Runs 21 and 22

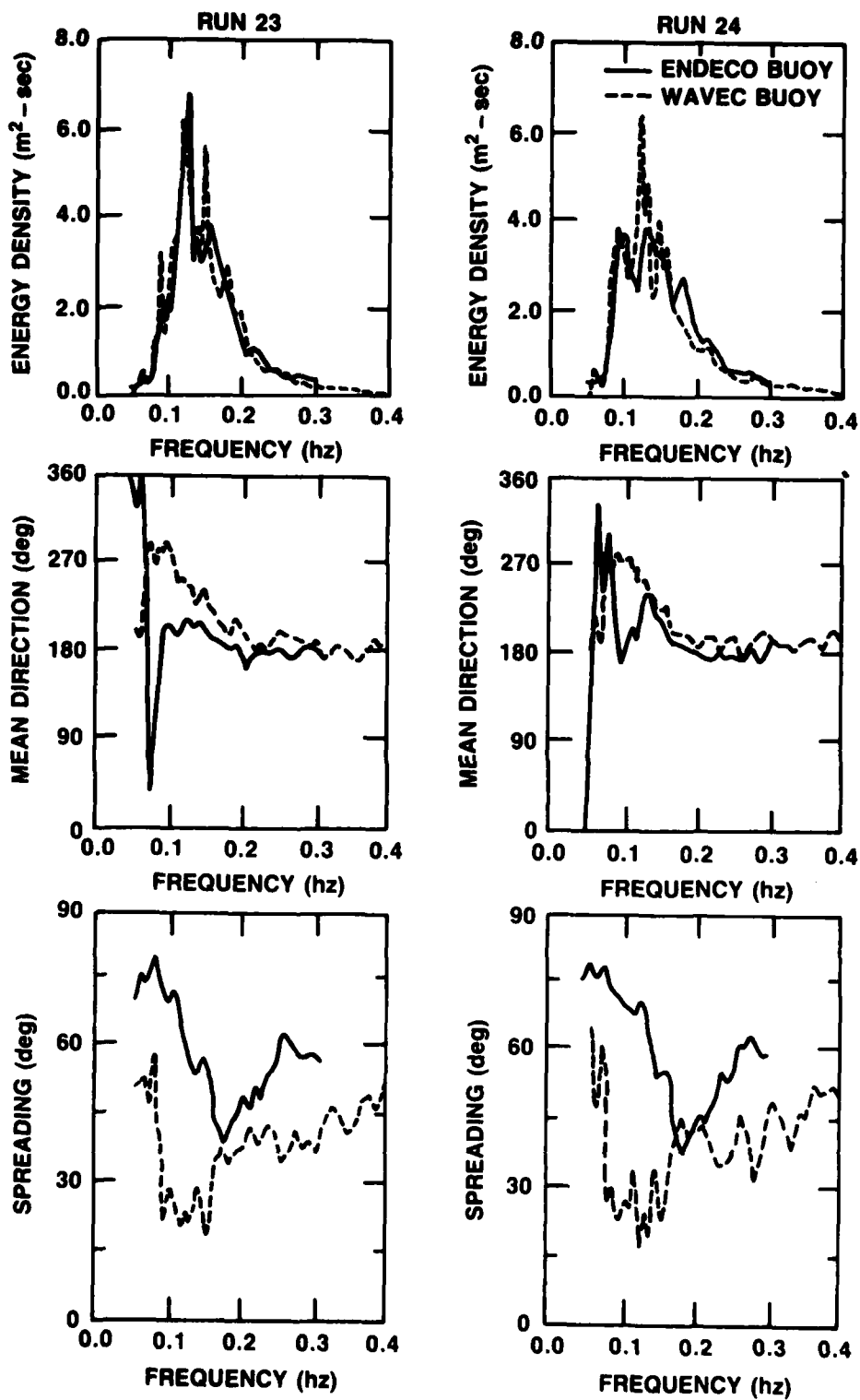

Figure 16 - Energy Densities, Mean Directions, and Spreading for Runs 23 and 24

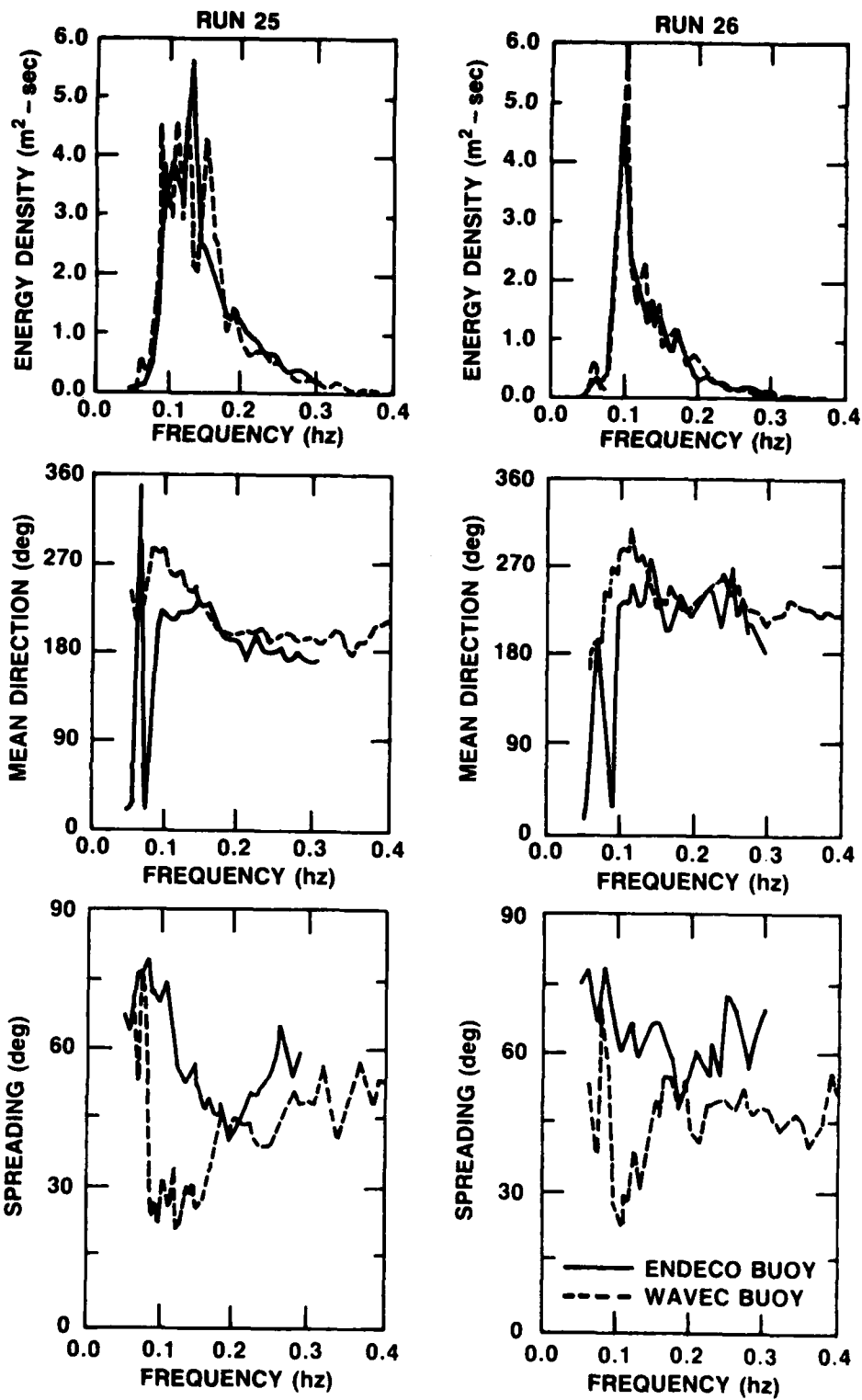

Figure 17 - Energy Densities, Mean Directions, and Spreading for Runs 25 and 26

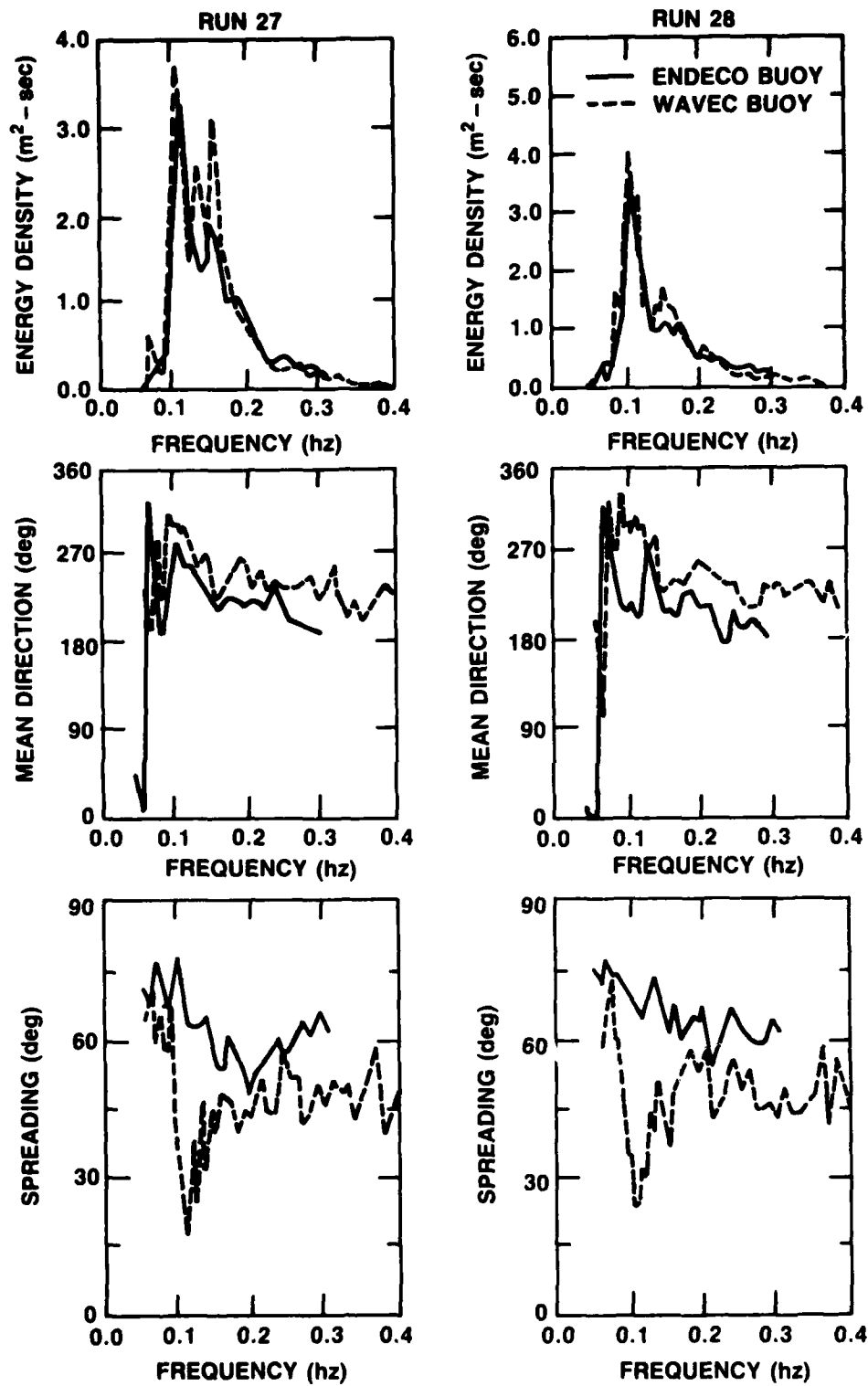

Figure 18 - Energy Densities, Mean Directions, and Spreading for Runs 27 and 28

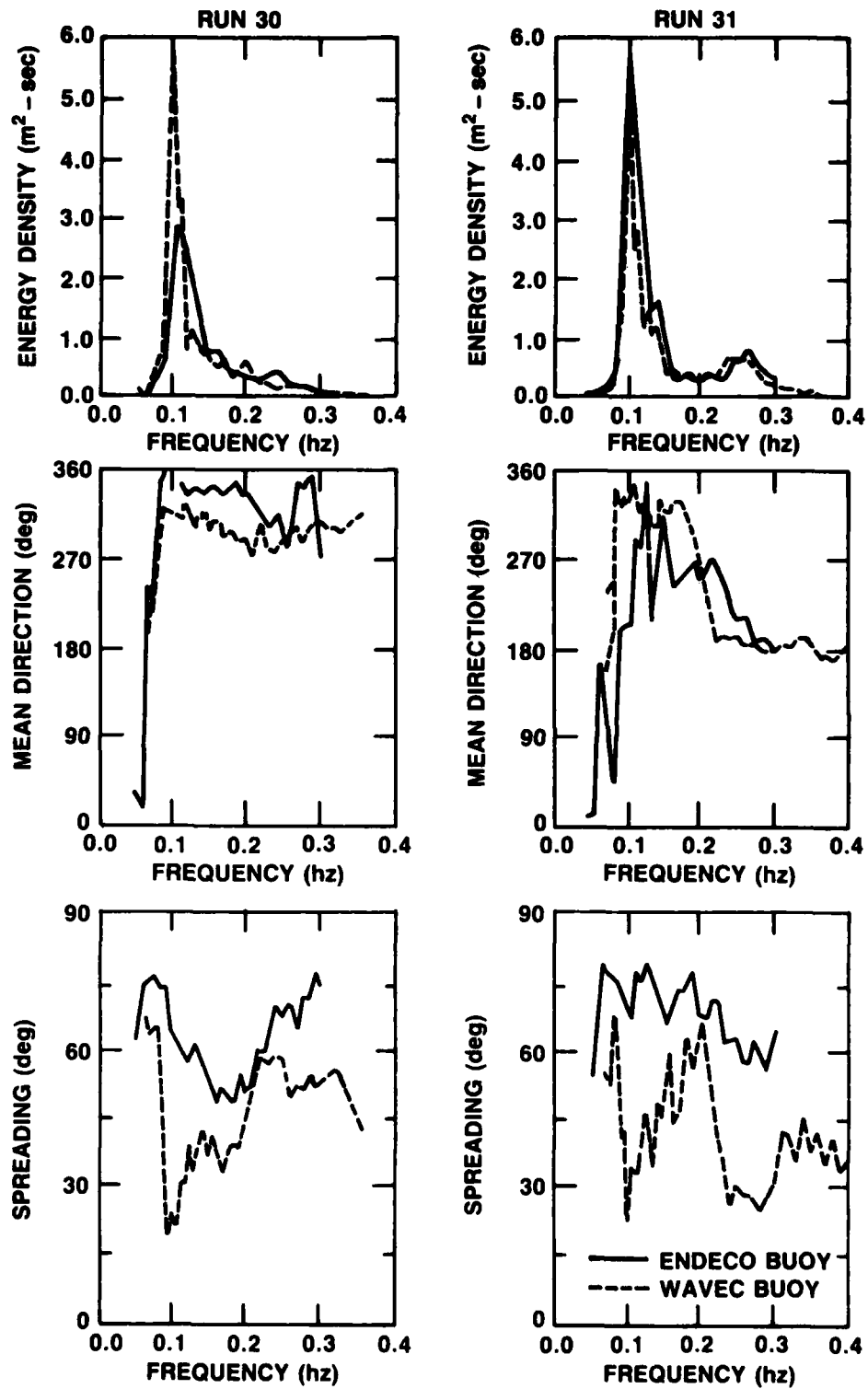

Figure 19 - Energy Densities, Mean Directions, and Spreading for Runs 30 and 31

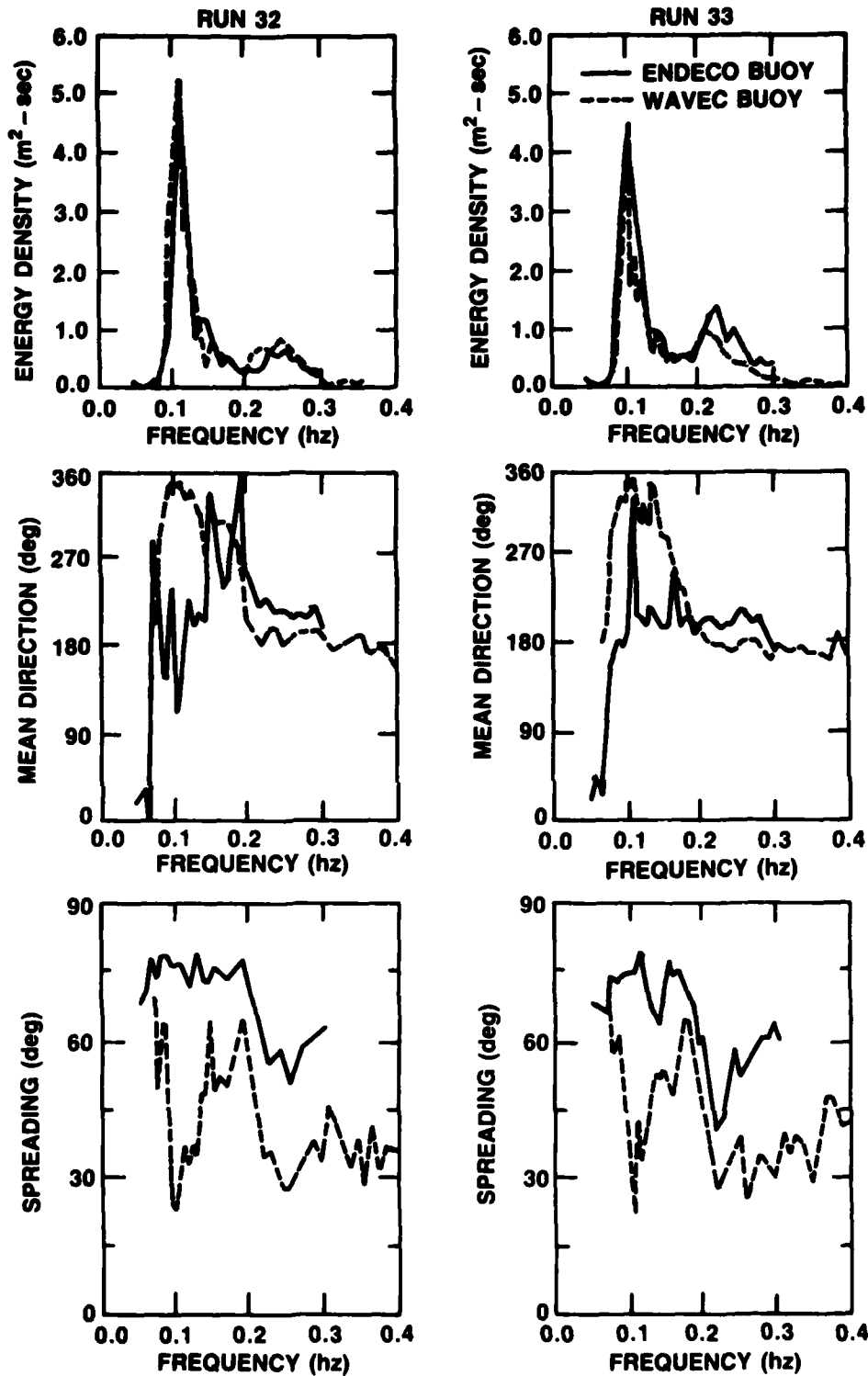

Figure 20 - Energy Densities, Mean Directions, and Spreading for Runs 32 and 33

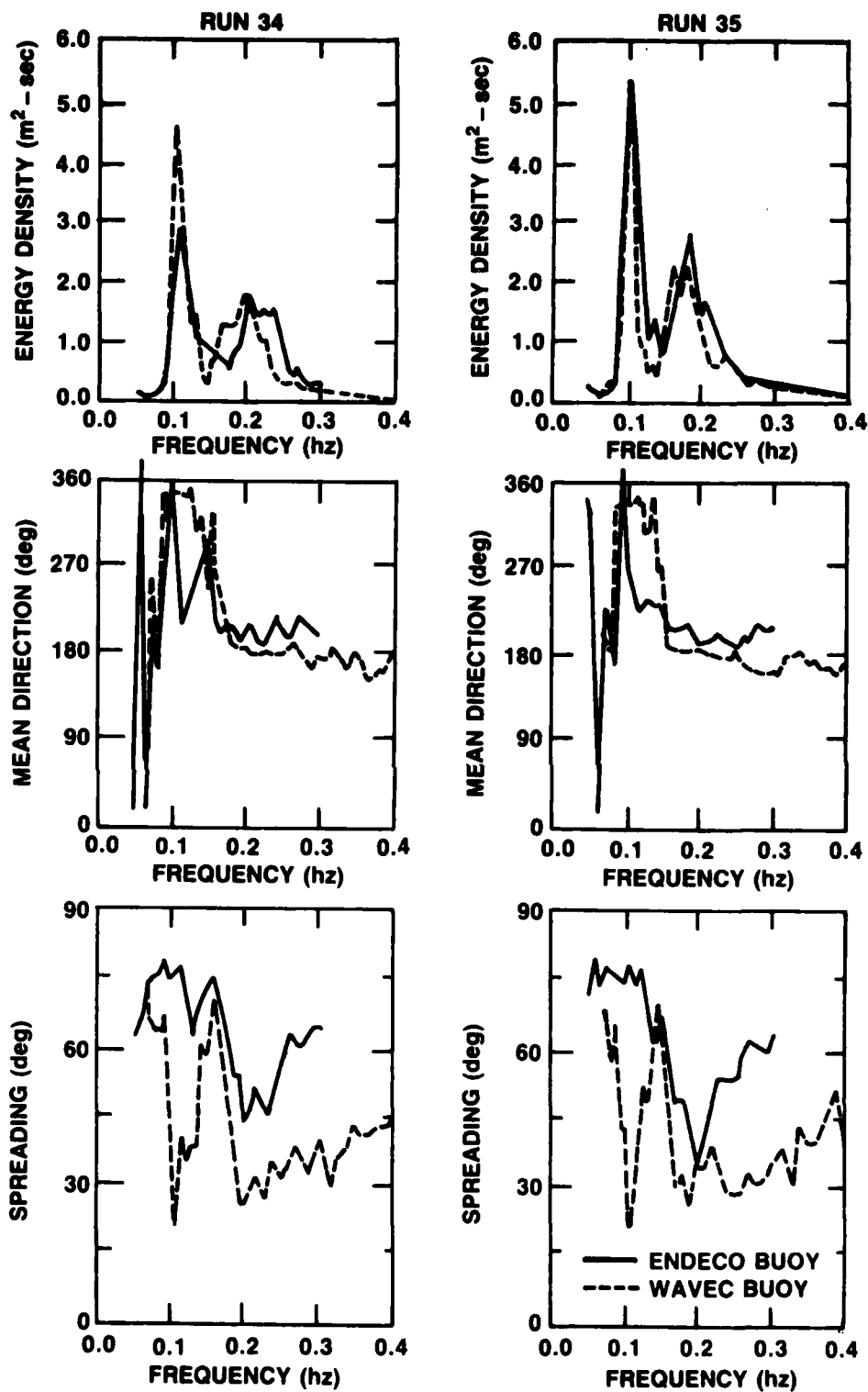

Figure 21 - Energy Densities, Mean Directions, and Spreading for Runs 34 and 35

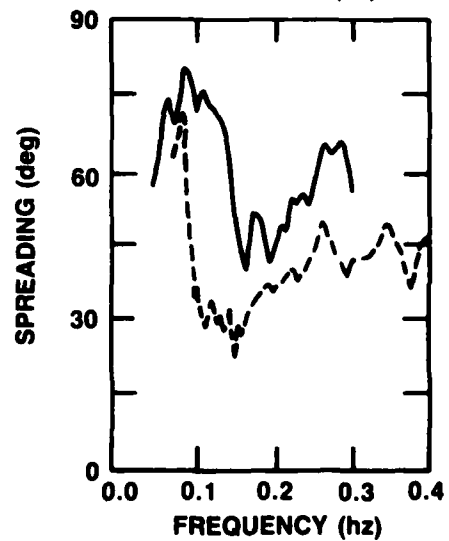
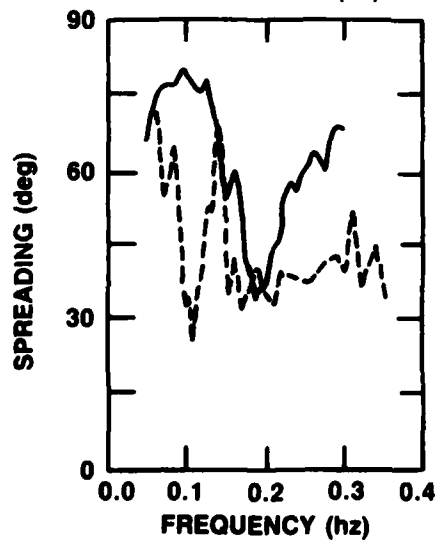
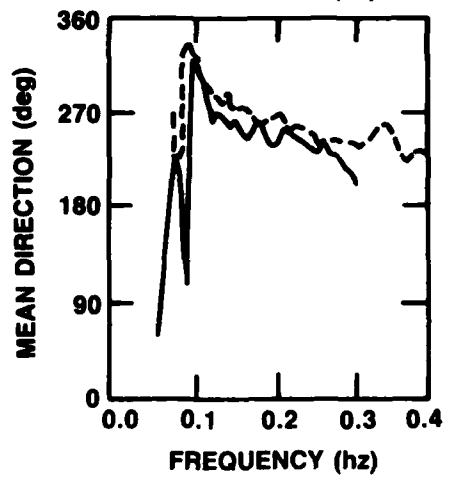
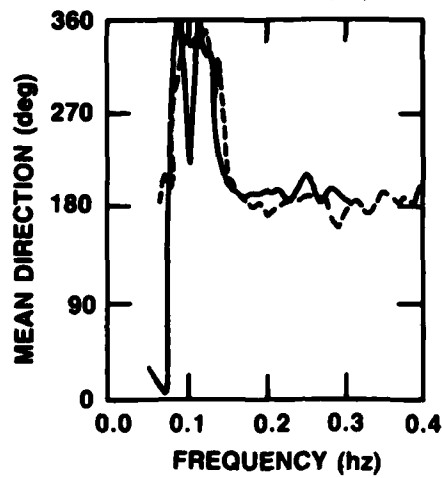
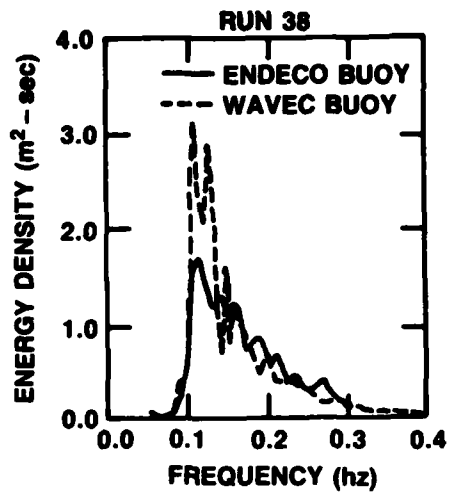
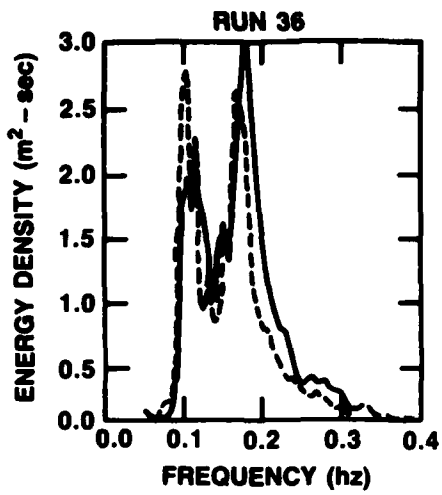

Figure 22 - Energy Densities, Mean Directions, and Spreading for Runs 36 and 38

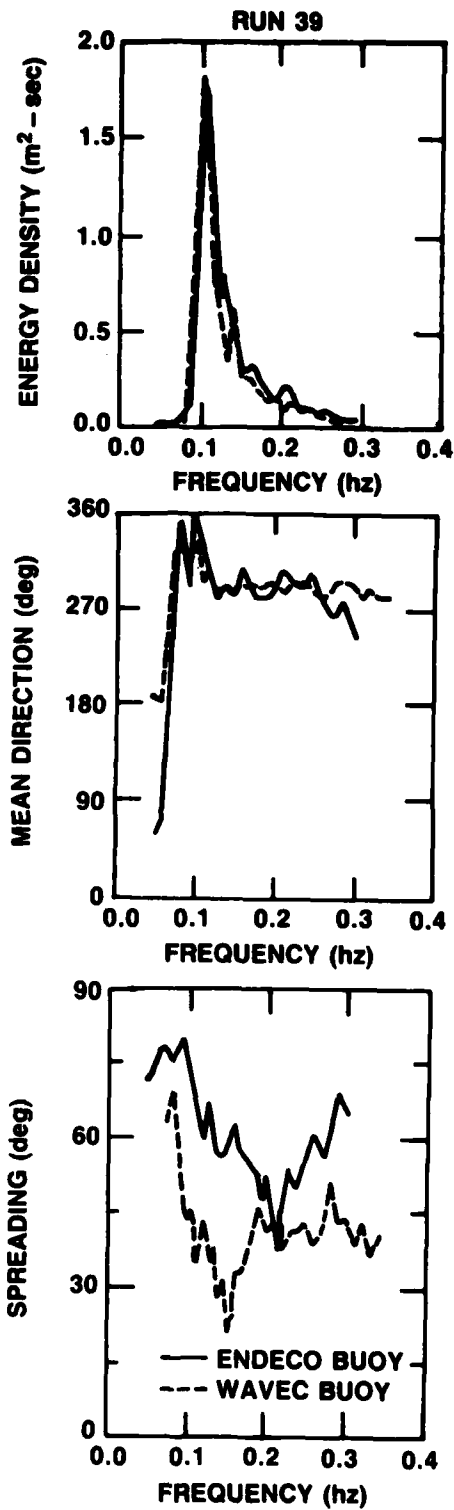

Figure 23 - Energy Density, Mean Direction, and Spreading for Run 39

TABLE 1 - TIMES AND LOCATIONS OF DATA COLLECTION

Run	Date	Time GMT	Location	Latitude (deg N)	Longitude (deg W)
3	5/14	1511-1555	2	50.4	11.2
4	5/14	1600-1631	2	50.4	11.2
5	5/14	1639-1709	2	50.4	11.2
6	5/14	1715-1745	2	50.4	11.2
7	5/14	1752-1820	2	50.4	11.2
8	5/14	1828-1857	2	50.4	11.2
9	5/14	1906-1935	2	50.4	11.2
10	5/15	0820-0851	3	50.3	11.1
11	-	-	-	-	-
12	5/15	0930-1000	3	50.3	11.1
13	-	-	-	-	-
14	5/15	1012-1042	3	50.3	11.1
15	-	-	-	-	-
16	5/15	1100-1130	3	50.3	11.1
17	5/15	1238-1309	3	50.3	11.1
18	-	-	-	-	-
19	5/15	1320-1350	3	50.3	11.1
20	5/15	1356-1426	3	50.3	11.1
21	5/15	1553-1623	3	50.4	11.1
22	5/15	1628-1658	3	50.4	11.1
23	5/15	1702-1732	3	50.4	11.1
24	5/15	1738-1802	3	50.4	11.1
25	5/15	1813-1843	3	50.4	11.1
26	5/16	0912-0942	4	50.3	14.4
27	5/16	0954-1034	4	50.3	14.4
28	5/16	1130-1200	4	50.3	14.4
29	-	-	-	-	-
30	5/17	0748-0818	5	46.6	15.5
31	5/18	0755-0825	6	45.2	20.5
32	5/18	0830-0900	6	45.2	20.5
33	5/18	0922-0952	6	45.2	20.5
34	5/18	0959-1029	6	45.2	20.5
35	5/18	1058-1128	6	45.2	20.5
36	5/18	1212-1242	6	45.2	20.5
37	-	-	-	-	-
38	5/19	1240-1337	7	41.2	20.2
39	5/20	1242-1312	8	37.3	20.3
40	5/21	1249-1319	9	32.4	20.4

DTNSRDC ISSUES THREE TYPES OF REPORTS

1. DTNSRDC REPORTS, A FORMAL SERIES, CONTAIN INFORMATION OF PERMANENT TECHNICAL VALUE. THEY CARRY A CONSECUTIVE NUMERICAL IDENTIFICATION REGARDLESS OF THEIR CLASSIFICATION OR THE ORIGINATING DEPARTMENT.

2. DEPARTMENTAL REPORTS, A SEMIFORMAL SERIES, CONTAIN INFORMATION OF A PRELIMINARY, TEMPORARY, OR PROPRIETARY NATURE OR OF LIMITED INTEREST OR SIGNIFICANCE. THEY CARRY A DEPARTMENTAL ALPHANUMERICAL IDENTIFICATION.

3. TECHNICAL MEMORANDA, AN INFORMAL SERIES, CONTAIN TECHNICAL DOCUMENTATION OF LIMITED USE AND INTEREST. THEY ARE PRIMARILY WORKING PAPERS INTENDED FOR INTERNAL USE. THEY CARRY AN IDENTIFYING NUMBER WHICH INDICATES THEIR TYPE AND THE NUMERICAL CODE OF THE ORIGINATING DEPARTMENT. ANY DISTRIBUTION OUTSIDE DTNSRDC MUST BE APPROVED BY THE HEAD OF THE ORIGINATING DEPARTMENT ON A CASE-BY-CASE BASIS.

END
FILMED

5-86

DTIC