

MICROCOPY RESOLUTION TEST CHART
NATIONAL BUREAU OF STANDARDS-1963-A

THE CONCEPT OF ALMOST-PARALLEL IFR APPROACHES TO PARALLEL RUNWAYS

A. C. SILVA

The MITRE Corporation
McLean, Virginia 22102

AD-A166 485



DTIC
ELECTE
APR 9 1986
S B D

MARCH 1986

Document is available to the U.S. public through
the National Technical Information Service
Springfield, Virginia 22161

DTIC FILE COPY

Prepared for
**U.S. DEPARTMENT OF TRANSPORTATION
FEDERAL AVIATION ADMINISTRATION**
OFFICE OF SYSTEMS STUDIES AND COOPERATIVE PROGRAMS
Washington, D.C. 20591

86 4 7 082

NOTICE

This document is disseminated under the sponsorship of the Department of Transportation in the interest of information exchange. The United States Government assumes no liability for its contents or use thereof.

1. Report No. FAA-DL5-86-1		2. Government Accession No. ADA 166485		3. Recipient's Catalog No.	
4. Title and Subtitle The Concept of Almost-Parallel IFR Approaches To Parallel Runways				5. Report Date March 1986	
				6. Performing Organization Code	
				8. Performing Organization Report No. MTR-86W00011	
7. Author(s) Armando C. Silva				10. Work Unit No. (TRAIS)	
9. Performing Organization Name and Address The MITRE Corporation 1820 Dolley Madison Blvd. McLean, Virginia 22102				11. Contract or Grant No. DTFA01-84-C-00001	
				13. Type of Report and Period Covered	
12. Sponsoring Agency Name and Address Department of Transportation Federal Aviation Administration Office of Systems Studies & Cooperative Programs Washington, D.C. 20591				14. Sponsoring Agency Code ADL-5	
				15. Supplementary Notes	
16. Abstract <p>Under today's rules independent parallel approaches are restricted to runways separated by at least 4300 feet. Currently the FAA is investigating a proposal to achieve reductions down to 3000 feet with the use of an improved surveillance system (1 milliradian accuracy/1 second update). This paper proposes new procedures to achieve such reductions, using existing radars, by executing "almost-parallel" MLS or ILS approaches. Almost-parallel approaches include curved paths where very shallow rates of turn are required and offset straight paths where the angle of offset with respect to the extended runway centerline is less than 3 degrees. Some issues of concern that arise, such as blunder resolution and pilot's loss of sight of other approach course during curved approaches, are discussed in this paper. Alternatives for an early implementation and site-specific sample applications are presented.</p> <p>The objective of this paper is to present in a concise manner this preliminary concept that has already generated some interest as a solution to reduced parallel operations. As with any new concept, analyses by all concerned parties have to be performed followed by simulations and/or demonstrations before the concept can be considered implementable.</p>					
17. Key Words Parallel Approaches, Air Traffic Control			18. Distribution Statement Available to the Public through the National Technical Information Service, Springfield, Virginia 22161.		
19. Security Classif. (of this report) Unclassified		20. Security Classif. (of this page) Unclassified		21. No. of Pages	22. Price

ACKNOWLEDGEMENTS

A large portion of the blunder analysis shown in this paper was based on previous work done by A. L. Haines and W. J. Swedish of The MITRE Corporation. They are authors of previous studies on independent parallel operations with reduced runway spacings. The author wishes to thank W. J. Swedish for reviewing this paper.

Previous efforts in developing proposals for offset ILS approaches to parallel runways include those of Lee Paul at the FAA Technical Center who proposed offset (splayed) localizer courses based on a recent simulation study of parallel approaches. Other efforts include the work by A. L. Haines for Aeroport de Paris and W. J. Swedish for FAA.

Special thanks go to J. N. Barrer whose guidance and inputs were critical throughout the development of this effort. Thanks to Dianne Thompson for typing this report.

S **DTIC**
ELECTE **D**
APR 9 1986
B

Accession For	
NTIS GRANT	<input checked="" type="checkbox"/>
DTIC TAB	<input type="checkbox"/>
Unannounced	<input type="checkbox"/>
Justification	
PER CALL JC	
By	
Distribution/	
Availability Codes	
Dist	Avail and/or Special
A-1	

SEE PER ON COVER BRASS

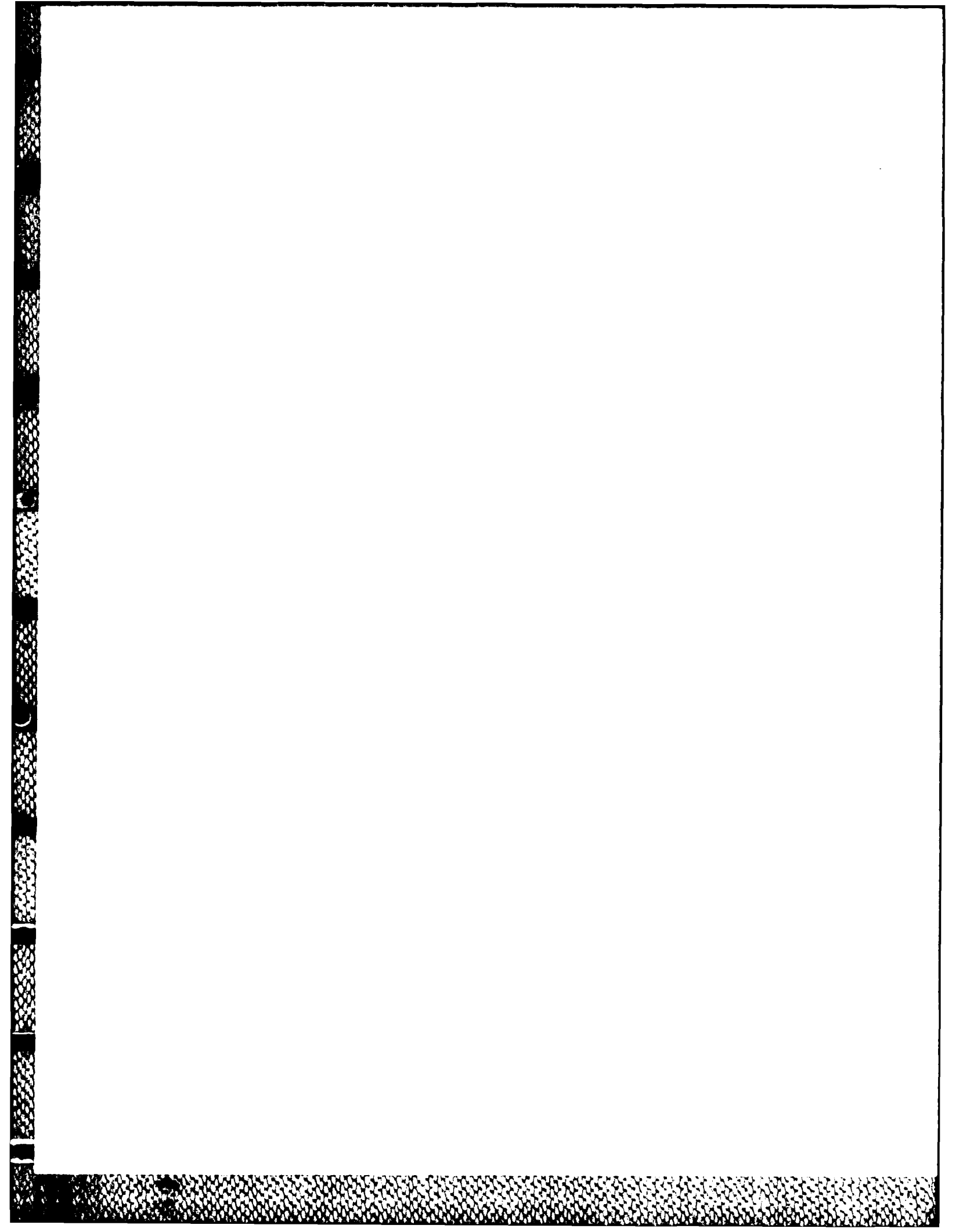

TABLE OF CONTENTS

	<u>Page</u>
1. INTRODUCTION	1-1
1.1 Background	1-1
1.2 Purpose and Scope	1-1
2. INDEPENDENT IFR PARALLEL APPROACHES	2-1
2.1 Independent IFR Parallel Approaches Under Today's Rules	2-1
2.2 Independent IFR Parallel Approaches with Reduced Spacings	2-1
3. NONSTRAIGHT-IN APPROACHES FOR INDEPENDENT IFR PARALLEL RUNWAY OPERATIONS	3-1
3.1 Proposed Procedures	3-1
3.1.1 Curved MLS Approaches to Parallel Runways	3-3
3.1.2 Offset Straight MLS Approaches to Parallel Runways	3-3
3.1.3 Offset Straight ILS Approaches to Parallel Runways	3-6
4. ISSUES OF CONCERN DURING NONSTRAIGHT-IN APPROACHES TO PARALLEL RUNWAYS	4-1
4.1 Loss of Sight of Other Approach Course	4-1
4.2 Blunder Analysis	4-1
5. IMPLEMENTATION ALTERNATIVES FOR THE TRANSITION PERIOD FROM ILS TO MLS	5-1
6. SITE-SPECIFIC APPLICATIONS	6-1
6.1 Sample Application of Almost-Parallel MLS Approaches - New York's Kennedy Airport	6-1
6.2 Sample Application of Almost-Parallel ILS Approaches - Memphis Airport	6-3
6.3 Other U.S. Airports with Potential for Almost-Parallel Approaches (MLS or ILS)	6-3
7. ADVANTAGES AND DISADVANTAGES OF ALMOST-PARALLEL APPROACHES TO PARALLEL RUNWAYS	7-1
7.1 Parallel Versus Almost-Parallel Approaches to Parallel Runways	7-1

TABLE OF CONTENTS
(Concluded)

	<u>Page</u>
7.2 Comparison of MLS, MLS/RNAV and ILS as Applied to Almost-Parallel Approaches	7-1
7.2.1 MLS/RNAV Applications	7-1
7.2.2 MLS Applications	7-2
7.2.3 ILS Applications	7-2
8. SUMMARY AND CONCLUSIONS	8-1
APPENDIX A: PROCEDURE TO CALCULATE RATES OF TURN AND ANGLES OF BANK	A-1
APPENDIX B: BLUNDER ANALYSIS	B-1
APPENDIX C: ACRONYMS	C-1
APPENDIX D: REFERENCES	D-1

LIST OF ILLUSTRATIONS

	<u>Page</u>
TABLE B-1: INPUT PARAMETERS BY ZONE	B-2
TABLE B-2: INPUT/OUTPUT PARAMETER DEFINITIONS	B-5
TABLE B-3: REQUIRED AND ACTUAL SEPARATIONS DURING ALMOST-PARALLEL CURVED APPROACHES	B-11
FIGURE 2-1: GEOMETRY OF INDEPENDENT PARALLEL APPROACHES	2-2
FIGURE 3-1: GEOMETRY OF CURVED APPROACHES TO PARALLEL RUNWAYS	3-4
FIGURE 3-2: GEOMETRY OF OFFSET STRAIGHT APPROACHES	3-5
FIGURE 3-3: ALMOST-PARALLEL ILS APPROACHES	3-8
FIGURE 4-1: COMPOSITION OF PARALLEL RUNWAY SPACING	4-3
FIGURE 4-2a: REQUIRED AND PROPOSED SEPARATIONS DURING ALMOST-PARALLEL CURVED APPROACHES	4-5
FIGURE 4-2b: REQUIRED AND PROPOSED SEPARATIONS DURING ALMOST-PARALLEL OFFSET STRAIGHT MLS APPROACHES	4-6
FIGURE 4-2c: REQUIRED AND PROPOSED SEPARATIONS DURING ALMOST-PARALLEL ILS APPROACHES	4-7
FIGURE 5-1: ILS AND MLS APPROACHES TO CLOSELY SPACED PARALLEL RUNWAYS - IMPLEMENTATION ALTERNATIVE	5-2
FIGURE 6-1: SAMPLE APPLICATION AT JFK	6-2
FIGURE 6-2: SAMPLE APPLICATION AT MEMPHIS	6-4
FIGURE A-1: PROCEDURE TO CALCULATE RATES OF TURN	A-2
FIGURE B-1: GEOMETRY OF CORRECTIVE TURN FOR STRAIGHT-IN PARALLEL APPROACHES	B-7
FIGURE B-2: CURVED APPROACH CASE	B-8

1. INTRODUCTION

1.1 Background

The problem of insufficient airport capacity has been affecting the normal operation of major air carrier airports for many years primarily during Instrument Flight Rules (IFR) conditions. The levels of traffic have risen causing delays and congestion which result in large losses for the airlines and in passenger inconvenience. Over 270,000 aircraft reported delays of more than 15 minutes at the 22 "pacing" airports in 1984 (Source: Federal Aviation Administration, National Aviation System Communications Staff (NASCOM) Office).

The Federal Aviation Administration (FAA) and the commercial aviation industry have long acknowledged this problem and sought solutions. The construction of new airports and runways is the most effective solution but requires several years, land availability and large capital expenditure. Several alternative operational solutions have been proposed to at least alleviate congestion and delays. Among these alternatives are the operation of multiple arrival streams during IFR (Reference 1); these would allow a more efficient use of runways at each airport thus increasing the airport's capacity. These multiple arrival stream concepts include:

1. Dependent parallel approaches at reduced runway centerline spacing;
2. Independent parallel approaches at reduced runway centerline spacing;
3. Dependent and independent approaches to converging runways;
4. Triple approaches; and
5. The use of separate short runways for General Aviation (GA) and commuter traffic.

1.2 Purpose and Scope

Currently there exists a proposal (Reference 2) for allowing independent parallel approaches at reduced centerline spacing using a new surveillance system. The purpose of this paper is to propose new procedures that involve the use of approaches not aligned with the centerline of the parallel runways and that could be implemented with the current surveillance systems.

Procedural methods for eliminating the need of a new approach surveillance system could save approximately \$5 million at each site. The purpose of this paper is to present the technical details of the almost-parallel concept.

Today's independent IFR parallel approaches and the current proposed procedure to reduce the minimum runway spacing are described in section 2. Section 3 presents the procedures proposed by this paper; some related issues of concern are discussed in section 4. Section 5 discusses implementation alternatives during the transition period from Instrument Landing System (ILS) to Microwave Landing System (MLS). Site-specific sample applications are described in section 6. Some advantages and disadvantages resulting from the use of almost-parallel approaches are presented in section 7. Section 8 contains a summary and conclusions.

2. INDEPENDENT IFR PARALLEL APPROACHES

2.1 Independent IFR Parallel Approaches Under Today's Rules

Under today's Air Traffic Control (ATC) rules (Reference 3) simultaneous IFR approaches to parallel runways are restricted to runways separated by a minimum of 4300 feet (1311 meters) (Figure 2-1). ATC procedures require:

1. Operational ILS, radar, and two-way communications system.
2. A vertical separation of 1000 feet (305 m) or a horizontal separation of 3 nautical miles (nmi) between the aircraft until establishment on the ILS localizer.
3. Two monitor controllers (in addition to the local controllers) to ensure the lateral separation between the aircraft in the event of a blunder during final approach.
4. Missed approach courses diverging by at least 45 degrees.

The geometry of the parallel approaches (Figure 2-1) shows the length needed for the final approach paths. The surveillance error with current radars at a point 9 nmi away from the antenna is one of the limiting factors in determining the 4300 foot minimum spacing (see Reference 2). The distance of 9 nmi follows from the assumption that the outer marker is located at 5 nmi from the threshold and that the radar antenna is located approximately 1 nmi from the threshold. Vertical separation of 1000 feet is lost at this 9 nmi point and the controller must rely on the accuracy of the radar to ensure lateral separation.

2.2 Independent IFR Parallel Approaches with Reduced Spacings

The minimum separation between runways that is required for parallel approaches depends on the accuracy and update rate of the surveillance radar. Hence, improvements in the radar system should allow reduced runway spacings during IFR parallel approaches. Reference 2 shows that reductions in spacing down to 3000 feet (914 m) may be obtained by using a radar with 1 milliradian azimuth accuracy and 1 second update rate. (Other parameters and requirements remain unchanged.)

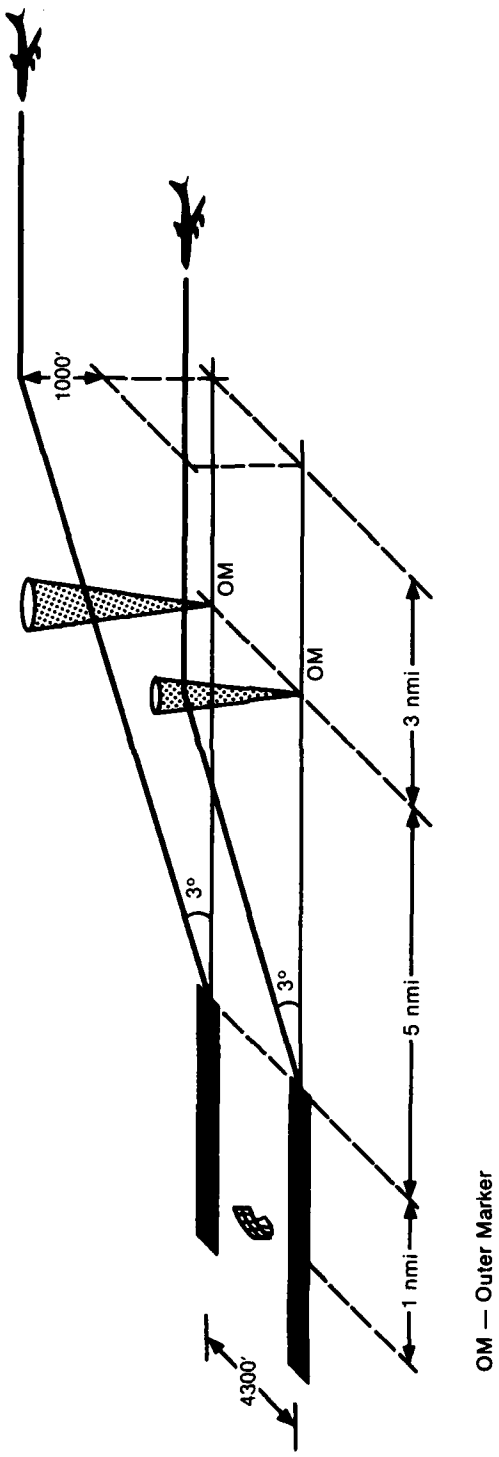

OM — Outer Marker

**FIGURE 2-1
GEOMETRY OF INDEPENDENT PARALLEL APPROACHES**

3. NONSTRAIGHT-IN APPROACHES FOR INDEPENDENT IFR PARALLEL RUNWAY OPERATIONS

As stated in section 2, the limitations of today's radars at a surveillance point 9 nmi away from the radar impose today's required minimum separation of 4300 feet between parallel runways. However, the surveillance error of these radars improves at points closer to the antenna. By using nonstraight-in approaches (curved, offset straight, or segmented), the final approach courses will be more than 4300 feet apart at the 9 nmi point. Depending upon the curvature or degree of offset, at least 4300 foot separations may be maintained to within a few miles of the antenna. At this distance, however, the reduced surveillance error of the radar will allow separations of less than 4300 feet. The procedures proposed in this paper make use of this concept to allow reductions to 3000 feet between runway centerlines.

There are precedents for the use of the nonstraight-in or offset final approaches being considered, e.g., Denver (where the FAA allows a 10 degree offset in the localizer for one of DEN's runways) and Paris (where approaches to runway 25 at Le Bourget Airport are offset by 25 degrees, Reference 4). At both sites a final visual turn before landing is required. At many airports, siting difficulties require that the localizer course be offset. As long as the degree of offset is less than 3 degrees, the decision height can be as low as 250 feet under today's ATC rules and procedures (Reference 5). A proposal for offsetting the ILS localizers to achieve reductions in parallel runway spacings was presented by Lee Paul of the FAA Technical Center in 1984 as a result of a simulation study on reduced parallel spacings.

3.1 Proposed Procedures

"Almost-parallel" approaches are defined as approaches to parallel runways where each approach is:

1. A curved/segmented approach where the required rate of turn is less than 0.3 degrees/second; or
2. An offset straight approach where the angle of offset with respect to the runway centerline is less than 3 degrees. (Under today's rules (Reference 5) a localizer offset of up to 3 degrees is considered acceptable.)

The main ATC and equipment requirements of the almost-parallel approaches would be the same as today's requirements except for on-board MLS equipment (avionics and computer) and an operational

MLS for the procedures that involve the use of MLS. Three possible procedures involving almost-parallel approaches are presented:

1. Curved/segmented MLS approaches to parallel runways;
2. Offset straight MLS approaches to parallel runways; and
3. Offset straight ILS approaches to parallel runways.

For the following description and analysis of the procedures, a reduced spacing of 3000 feet between parallel runways is considered. Obviously the procedures apply to separations of more than 3000 feet.

A speed during final approach of 140 knots at 3 nmi from the runway thresholds has been assumed. Higher speeds are unlikely and lower speeds only facilitate the application of the procedures.

The separations between aircraft, the distances from the thresholds and the rates of turn defined in the following sections are adjustable parameters and have been chosen to illustrate the almost-parallel concept.

The use of the MLS may allow curved, segmented, or offset final approaches to parallel runways. By taking advantage of these capabilities, independent (simultaneous) IFR approaches to parallel runways at reduced runway spacings may be achieved. Furthermore, these reductions may be achieved without new or improved surveillance systems. The flexibility of MLS allows approach procedures to be adapted to site characteristics and existing surveillance accuracy. In addition MLS can provide precision guidance and the potential for Category II or III minima for almost-parallel approaches. It should be remembered that it has been established that internationally MLS will eventually replace ILS.

Some technical issues related to MLS, such as the siting of antennas, would need to be resolved prior to the application of two of the following almost-parallel procedures. Such technical issues, though, are beyond the scope of this paper.

The almost-parallel ILS approaches proposed in section 3.1.3, although not having the segmented approach flexibility of MLS, may allow for an earlier implementation since the wide use of MLS is still a few years away.

3.1.1 Curved MLS Approaches to Parallel Runways

This procedure is shown drawn approximately to scale in Figure 3-1. It calls for establishing a 4300 foot separation between final approach paths at a point 3 nmi away from the runway's thresholds. A 4300 foot separation has been selected because it is today's allowed minimum and therefore constitutes an accepted standard. The aircraft arrive at this 3 nmi/4300 foot separation point by flying curved or straight paths that may depend on site-specific considerations. Starting at this point, where the 4300 foot separation is lost, aircraft fly a very shallow curved path to a point 1 nmi away from the threshold. The distance of 2 nmi was chosen to allow adequate distance to maneuver from 4300 feet to 3000 feet separation. The adequacy of this distance will be shown in subsequent sections although other distances are entirely possible. The rate of turn required to execute such a curve is approximately 0.1 degrees/second. (Calculations are shown in Appendix A). This involves a bank angle of about 1 degree. From this 1 nmi point, the aircraft fly straight-in parallel approaches until touchdown. The analyses for the MLS approaches shown in this report refer only to the portion of the final approaches to parallel runways where the 4300 foot separation between the two aircraft is lost.

3.1.2 Offset Straight MLS Approaches to Parallel Runways

The offset straight approach procedure also calls for bringing the two aircraft on approaches to parallel runways to points 3 nmi away from the thresholds that have a separation of 4300 foot between paths (Figure 3-2). Both aircraft continue along a straight course until they reach the runway centerline at a point approximately 1/2 mile from the threshold. The angle of offset of this trajectory with respect to the extended runway centerline is approximately 2 degrees. Therefore, the aircraft need to execute a 2 degree turn before landing to line up with the runway.

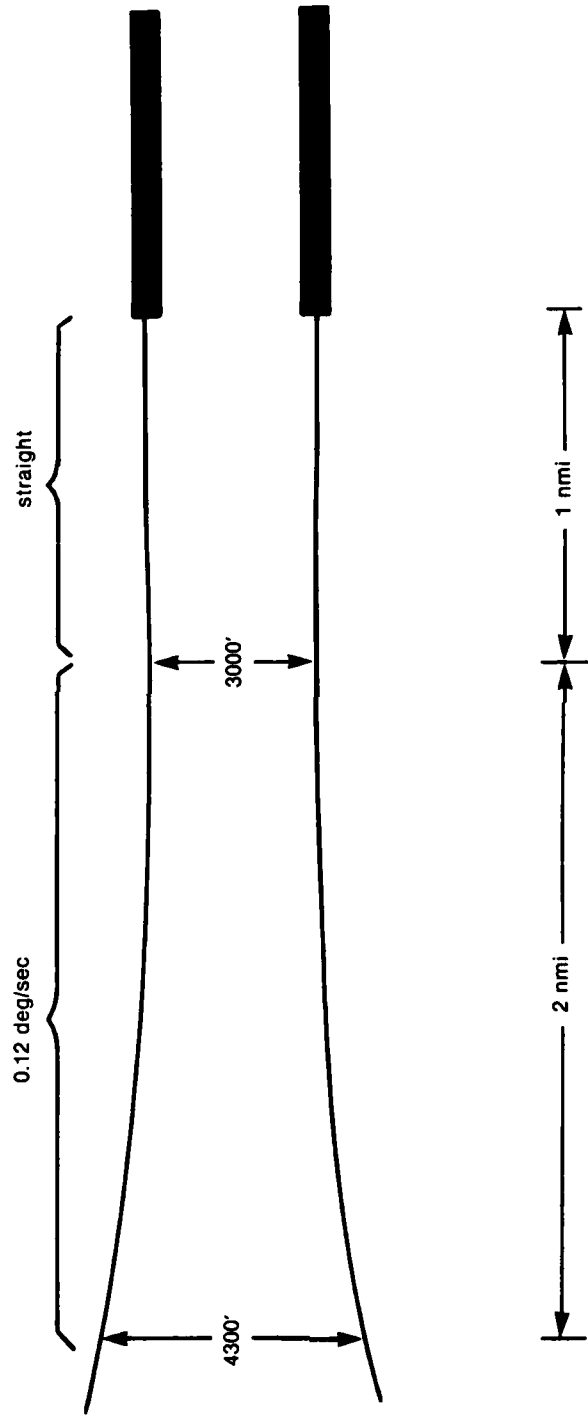

**FIGURE 3-1
GEOMETRY OF CURVED APPROACHES TO PARALLEL RUNWAYS**

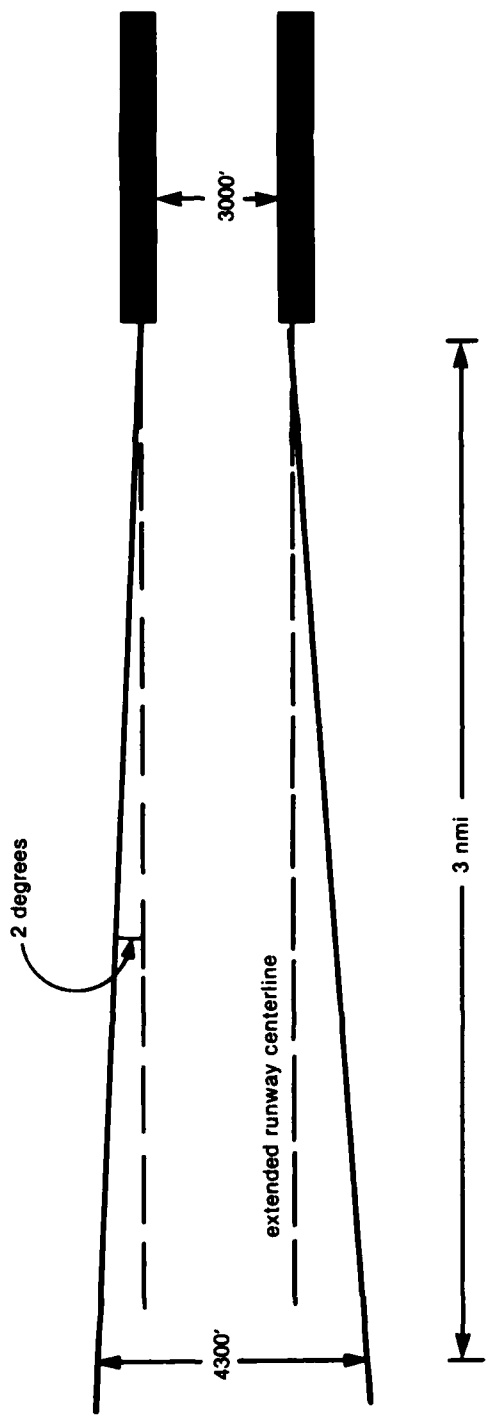

**FIGURE 3-2
GEOMETRY OF OFFSET STRAIGHT APPROACHES**

3.1.3 Offset Straight ILS Approaches to Parallel Runways

Although MLS is expected to allow segmented approaches and to provide a much greater flexibility and accuracy than ILS, almost-parallel approaches with the exclusive use of ILS could be implemented at an earlier date. The operation of almost-parallel approaches with ILS would only require a slight offset of the antenna and the development of the appropriate ATC procedures.

Given that ILS procedures and equipment have long been established and operating, two principal assumptions for the almost-parallel concept application with the use of ILS-only have been made so that changes with respect to today's operations are minimized. The first assumption is that current ATC rules for ILS approaches and for approaches to parallel runways will, for the most part, remain unchanged. This implies the following:

1. Two aircraft on approaches to parallel runways will maintain a minimum altitude separation of 1000 feet until establishment on the localizer occurs. (This will result in a length of final approach of approximately 9 nmi, as described in section 2 for today's parallel operations.)
2. A minimum decision height of 250 feet is used.
3. The offset course intersects the extended runway centerline at a point between 1100 and 1200 feet beyond the missed approach point towards the runway threshold. (For a 250 foot decision height and a 3 degree glide slope the intersection occurs at approximately 3500 feet from the threshold.)
4. The blunder recovery procedures remain the same, i.e., if an aircraft blunders toward the parallel approach course, the controller instructs the nonblundering aircraft to turn to a course parallel to that of the blunderer.

The second principal assumption is that the offset of only one of the approaches to the parallel runways is the preferred procedure. Some advantages of offsetting only one ILS are that one approach will remain normal straight-in thus allowing the retention of ILS CAT II and CAT III capability, that it is less expensive to offset only one of the ILSs, and that there are smaller probabilities of altering established back-course guidance.

Taking into consideration the two assumptions described above, the following almost-parallel ILS-only procedure, shown graphically in Figure 3-3, is proposed: Offset one ILS approach by approximately 2 degrees (strictly, the minimum turn required is 1.6 degrees) while keeping the other approach straight-in along the extended runway centerline. The offset course intersects its extended centerline at 1200 feet beyond the missed approach point. Therefore, at 3500 feet from the runway threshold the aircraft will execute a 2 degree turn that will align it with the runway. A 2 degree turn to touchdown is discussed in section 4.2 in reference to its acceptability in a blunder situation. The required turn may vary according to site-specific geometries. Figure 3-3 shows a general case where the spacing between runways is 3000 feet and the thresholds are not staggered. The localizer antenna would have to be moved approximately 200 feet to the inside of the runway pair in order to generate a 2 degree offset course. A 2 degree offset represents a 4750 feet lateral separation between courses at the 9 nmi range (where the 1000 foot altitude separation is lost). Larger angles of offset may be used depending on the desired lateral separation between approach courses, as long as the geometry is suitable for a safe blunder recovery procedure. For example, if a 4300 foot separation at the Outer Marker (assumed located at 5 nmi from the threshold) is desired, the required angle of offset would be 2.3 degrees.

A site-specific application of almost-parallel ILS approaches is given in section 6.2. For site-specific applications it is preferred to offset the localizer of the lowest category ILS, and not to offset an ILS if it is also used for back-course approaches.

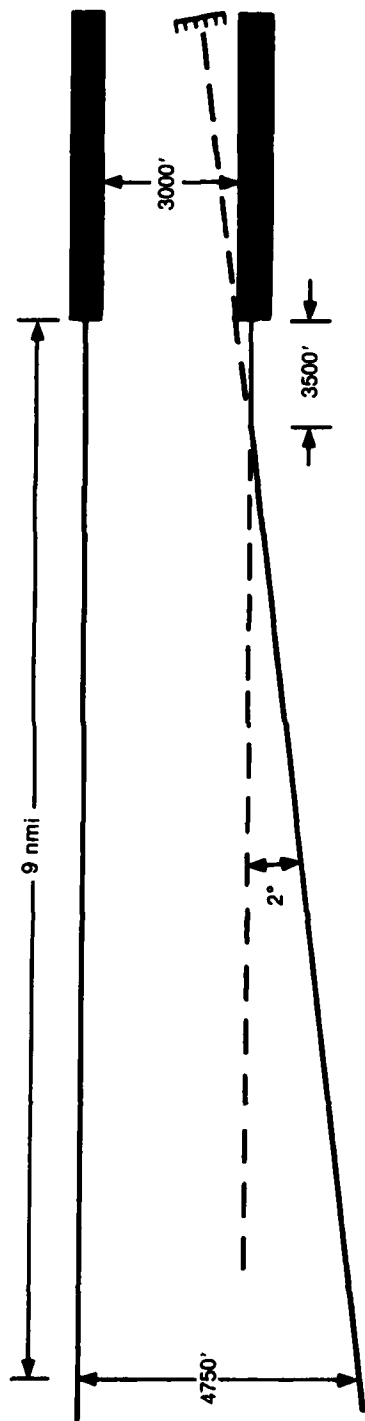

**FIGURE 3-3
ALMOST-PARALLEL ILS APPROACHES**

4. ISSUES OF CONCERN DURING NONSTRAIGHT-IN APPROACHES TO PARALLEL RUNWAYS

Several concerns arise regarding the implementation of almost-parallel approaches to parallel runways with reduced centerline spacing. The two most important concerns are the pilot's loss of sight of the other approach course due to aircraft banking during the turn, and the safe resolution of blunders or "overshoots" by one of the aircraft involved. These two issues are analyzed in this section.

4.1 Loss of Sight of Other Approach Course

Most IFR approaches are concluded by clearing the aircraft for a visual final approach. The pilot must provide visual separation during the last few miles of the approach if he or she accepts the clearance. This raises the question whether the bank angle required to execute a curved almost-parallel approach could cause loss of sight of the other approach course.

The rate of turn necessary to fly the curve from the 3 nmi/4300 foot separation point to the 1 nmi/3000 foot separation point is 0.12 degrees/second. At the assumed speed of 140 knots, the angle of aircraft bank required to execute such rate of turn is less than 1 degree. (The methodology to calculate angle of bank is shown in Appendix A.) An angle of bank of less than 1 degree is obviously very low and does not affect the pilot's capability to see the other aircraft. Therefore, loss of sight of the other approach course due to aircraft banking is not an issue of concern in the proposed procedure for curved approaches to parallel runways.

4.2 Blunder Analysis

The blunder analysis for nonstraight-in approaches is based on the analysis for independent parallel instrument approaches (Reference 2). The almost-parallel conditions (e.g., very low rates of turn) under which the nonstraight-in approaches are executed allow a blunder analysis similar to that of straight-in parallel approaches.

The same blunder resolution procedures used for the current ILS parallel operations are assumed. If one of the aircraft blunders toward the parallel (or almost-parallel) approach course, the monitor controller instructs the nonblundering aircraft to take

evasive action by initially turning to a course parallel to that of the blundering aircraft. Currently, there is no available data on the lateral positional accuracy of a curved MLS approach. A key assumption in the blunder analysis for nonstraight-in MLS approaches is that the MLS navigation accuracy is at least as good as that of ILS. Based on MLS specifications and preliminary reports from the FAA, the navigation accuracy possible with MLS should be higher than that of ILS.

The blunder analysis has been performed for the three almost-parallel proposed procedures using the same composition of the minimum parallel runway spacing defined for today's straight-in parallel approaches. That is, the spacing between the runways is divided into five zones: the Normal Operating Zone (NOZ), the Detection Zone (DZ), the Delay Zone (DEL), the Correction Zone (CZ), and the Miss Distance (MISS). (Figure 4-1).

An analysis and recalculation has been performed for each of the zones that form the parallel runway spacing (Appendix B). During almost-parallel approaches, the behavior of the nonblunderer changes while the behavior of the blunderer is the same as in the case of two straight parallel approaches.

The blundering aircraft is assumed to have a 30 degree heading error. In order for the nonblunderer to recover, it must turn 30 degrees plus an additional amount due to the included angle between the courses.

Of the five zones, only the analysis of the correction zone changes as a result of nonstraight-in approach paths, because the CZ is the only zone that depends on the behavior of the aircraft executing an evasive maneuver (nonblunderer). The CZ increases to account for an additional angle of turn by the nonblunderer to a course parallel to the blunderer. This additional angle of turn is due to the fact that prior to the blunder both aircraft do not follow parallel courses.

Using the same logic that was used to show that 4300 feet is the minimum separation allowed by today's radar at 9 nmi, an analysis was performed to calculate the minimum separation closer to the radar. For example, at the 3 nmi point the required minimum spacing for almost-parallel curved approaches using today's radar turns out to be 3628 feet. By way of comparison, for today's straight-in parallel approaches the minimum spacing required with current radars at a point 3 nmi away from the thresholds would be 3125 feet. The curvature of the nonblunderer's course requires an additional 500 feet in the

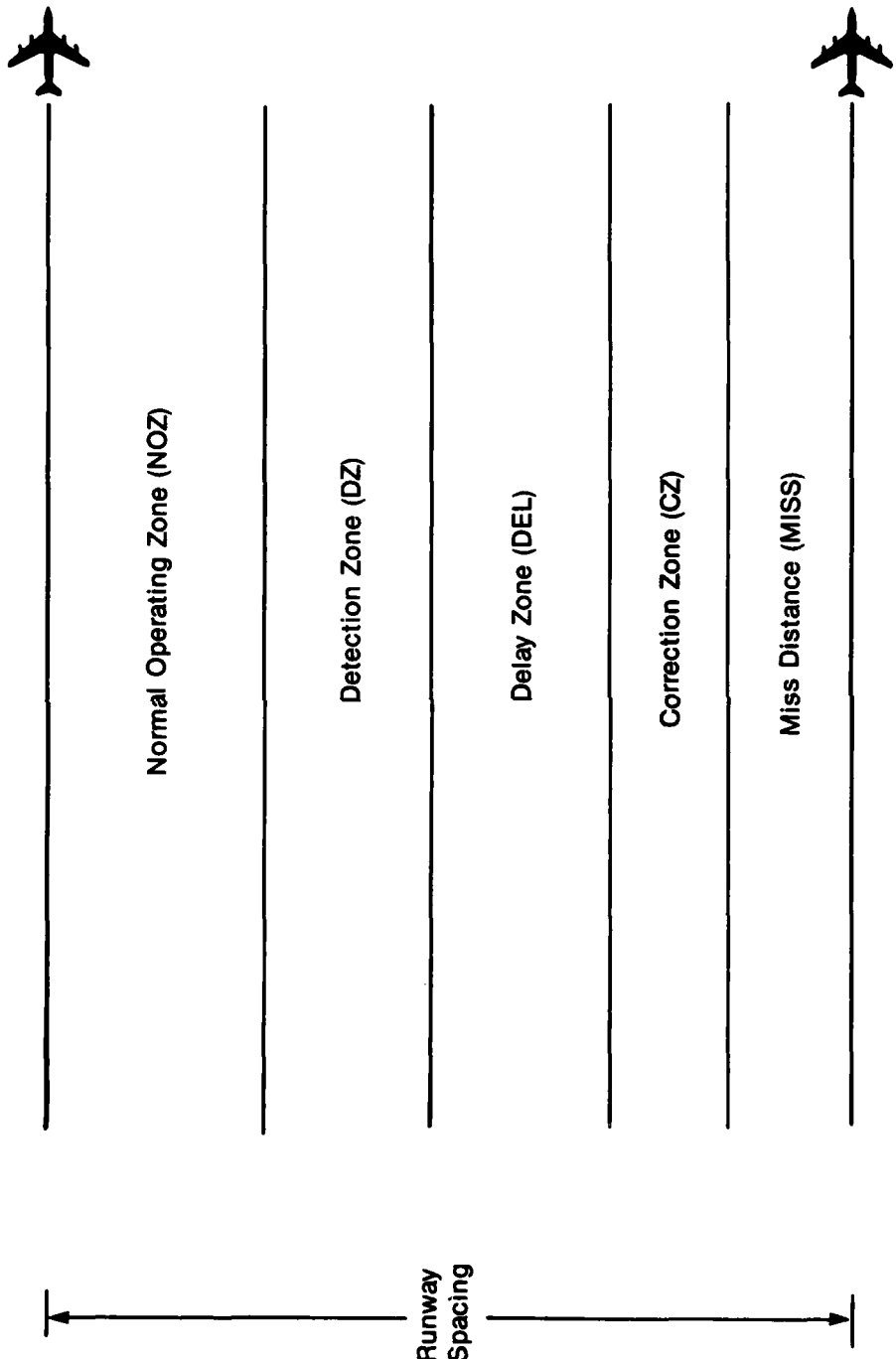

**FIGURE 4-1
COMPOSITION OF PARALLEL RUNWAY SPACING**

Correction Zone. At the 3 nmi point the proposed procedure establishes a 4300 foot separation; this is well above the required minimum of 3628 feet. Hence, the proposed procedure not only complies with the minimum required for safe blunder resolution but it allows an additional separation between aircraft paths. Thus the new procedures have the added advantage that at any point on the proposed curved paths, the actual separation is larger than the required minimum at that point. Figure 4-2a and Table B-3 in Appendix B provide a comparison between the separations resulting from the proposed curved paths and the required minimum separations (derived from the blunder analysis) for points where the 4300 foot separation is lost. At points closer to the runways than the 3 nmi point aircraft paths come closer to each other but the surveillance and navigation errors decrease and the additional angle of turn by the nonblunderer becomes smaller. As seen in Figure 4-2a, the required minimum spacings become smaller and remain below the actual separation.

Figures 4-2b and 4-2c provide the same comparison for the almost-parallel offset straight MLS and ILS approach cases respectively. In both cases the proposed paths yield separations which are larger than the minimum required. (Figure 4-2c shows the separations starting at a distance of 9 nmi instead of 3 nmi because the ILS case does not allow segmented approaches to the 3 nmi point.)

All calculations have been performed assuming ILS accuracies. Runway spacings obtained should, therefore, be conservative for MLS approaches if MLS accuracy is actually greater than that of ILS. One of the requirements that must be met prior to implementation of curved approaches is the verification that the navigation accuracy along a slightly curved MLS course is indeed as good as ILS (straight course) accuracy.

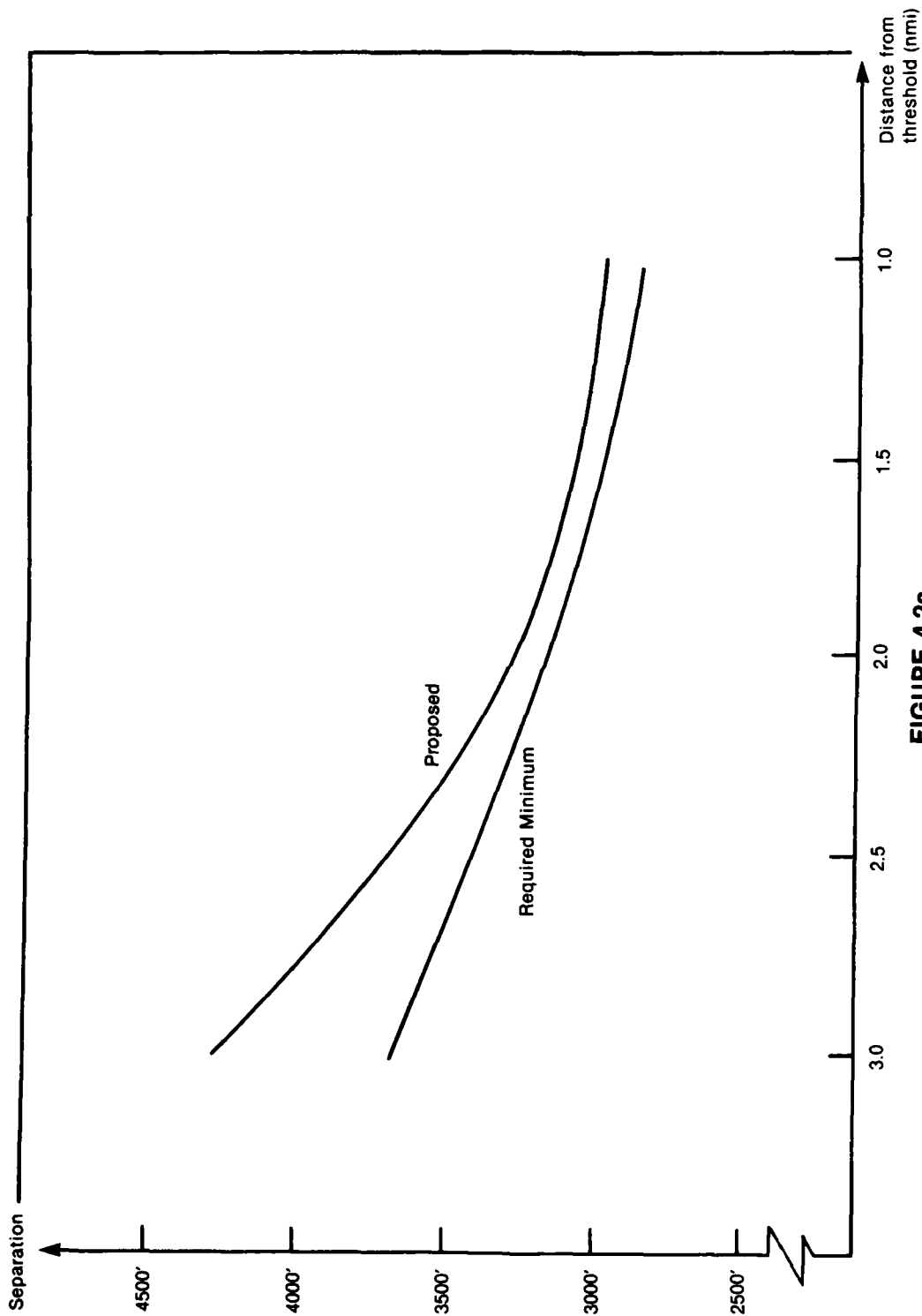

FIGURE 4-2a
REQUIRED AND PROPOSED SEPARATIONS DURING
ALMOST-PARALLEL CURVED APPROACHES

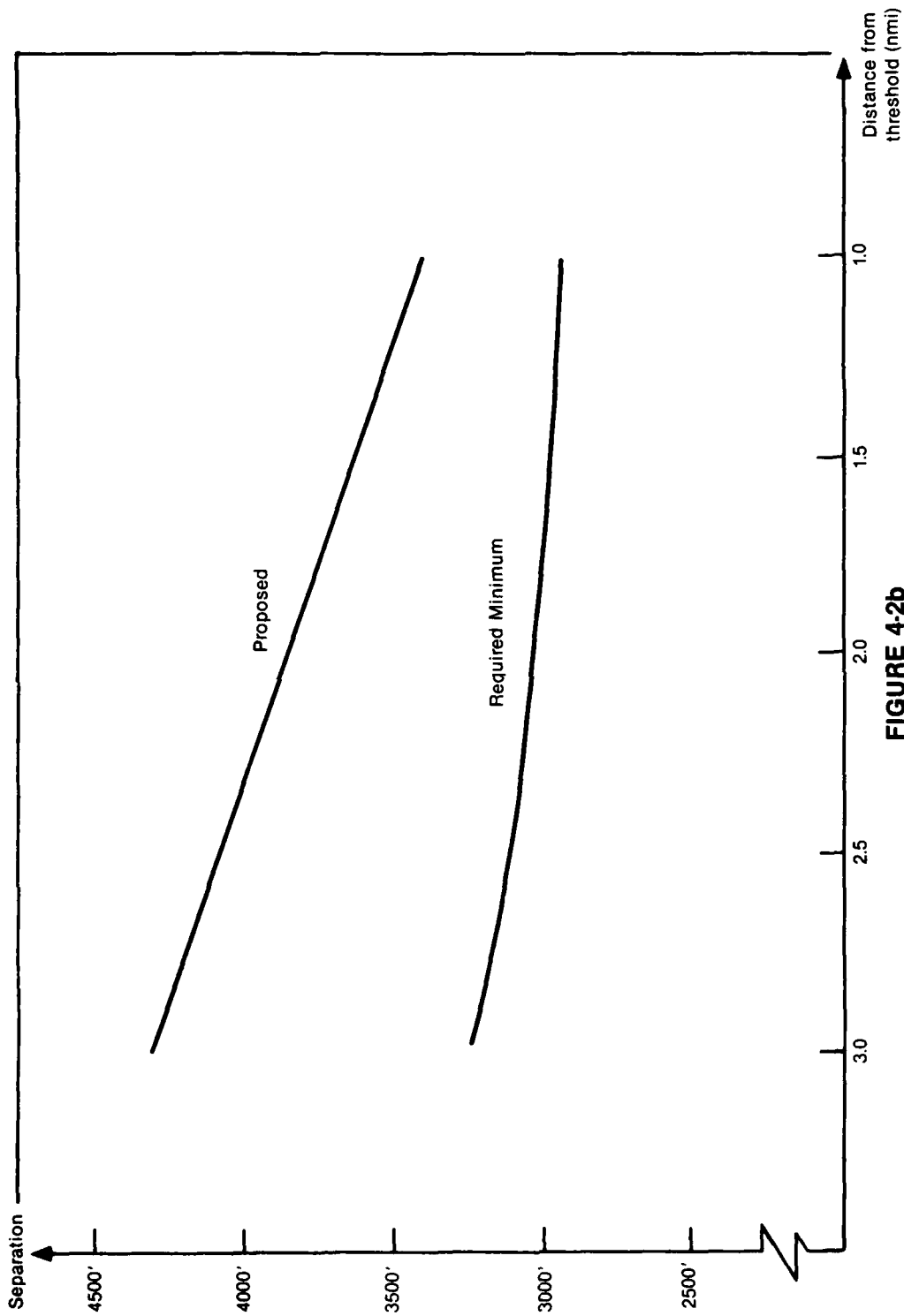

FIGURE 4-2b
REQUIRED AND PROPOSED SEPARATIONS DURING
ALMOST-PARALLEL OFFSET STRAIGHT MLS APPROACHES

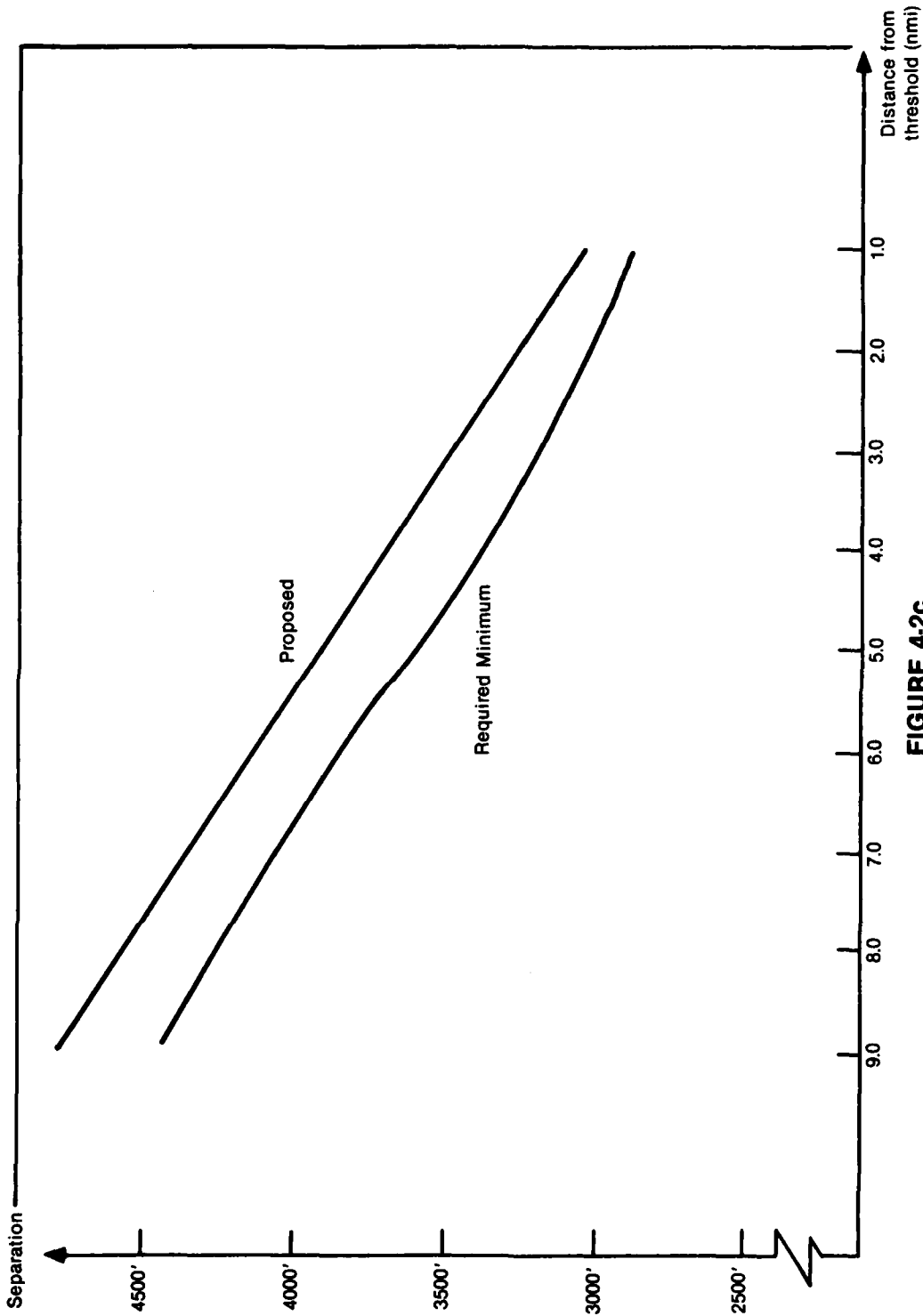

FIGURE 4-2c
REQUIRED AND PROPOSED SEPARATIONS DURING
ALMOST-PARALLEL ILS APPROACHES

5. IMPLEMENTATION ALTERNATIVES FOR THE TRANSITION PERIOD FROM ILS TO MLS

Before the full implementation of MLS and the phase-out of ILS take place, a transition period will be needed in which both systems may coexist. There are several alternatives for implementing the concept of reduced parallel spacing with almost-parallel approaches during the transition period. One alternative is to equip one of the parallel runways with MLS and the other with conventional ILS.

1. Aircraft equipped with ILS execute normal straight approaches to the ILS-equipped runway (Figure 5-1). This would allow the retention of ILS CAT II or III capability if required.

2. Aircraft equipped with MLS execute a curved approach to the MLS-equipped runway. (To maintain a 4300 foot separation at the 3 nmi point and line up with the runway at a point 1 nmi away from the threshold, the required rate of turn is 0.24 degrees/ second. This is still a very low rate of turn and complies with the blunder analysis.)

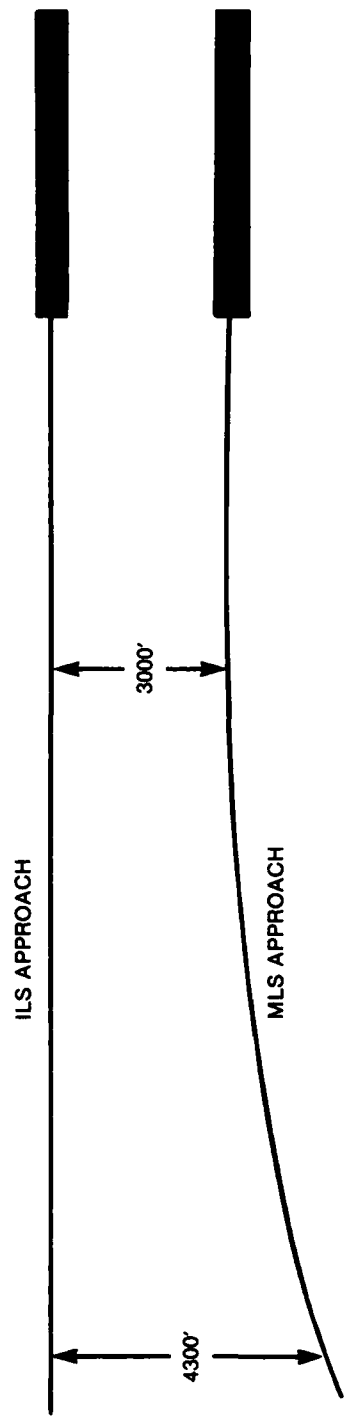

FIGURE 5-1
ILS AND MLS APPROACHES TO CLOSELY SPACED PARALLEL RUNWAYS
IMPLEMENTATION ALTERNATIVE

6. SITE-SPECIFIC APPLICATIONS

6.1 Sample Application of Almost-Parallel MLS Approaches - New York's Kennedy Airport

An example of the use of almost-parallel MLS approaches at reduced runway spacings has been developed for New York's Kennedy Airport (JFK). Any of the proposed MLS or ILS almost-parallel procedures is applicable to JFK. This particular alternative has been chosen only for illustrative purposes.

The application calls for implementing the alternative mentioned in section 5, i.e., one straight (ILS) approach and one curved (MLS) approach to parallel runways, on runways 4L and 4R at JFK. ILS straight-in approaches would be run to runway 4L (over 11,000 feet long) and curved MLS approaches would be run to runway 4R (8400 feet long). Aircraft not equipped with MLS would land on runway 4L; aircraft equipped with MLS would land on runway 4R. Runways 4L and 4R have staggered thresholds which may facilitate the application of this concept since separations between aircraft are larger at points closer to the threshold. No major noise problems would be expected since the final approaches to runways 4L and 4R would be mostly over water. (See Figure 6-1.)

While the 4L, 4R arrival configuration is in use, departures would be conducted on runway 31L (and possibly 4L). Runway 31L is approximately 14,500 feet long but because it intersects runway 4L, the length to be used for departures would be reduced; about 12,000 feet would still be left for takeoffs. Departing aircraft would execute a left turn over Jamaica Bay and then proceed out to sea thus avoiding noise problems. This runway configuration is feasible when there is no wind or when winds are from the North. Airspace restrictions and missed approach procedures would be similar to those currently applied when the 4L/4R configuration at JFK is used, although specific missed approach procedures for simultaneous arrivals would have to be developed. Currently, runway 4L is used for departures when 4R is used for arrivals. Departures off runway 31L are currently used and procedures exist to account for the terminal airspace interactions with other airports in the area. This application at JFK could conceivably double Kennedy's arrival capacity over the current use of 4L and 4R.

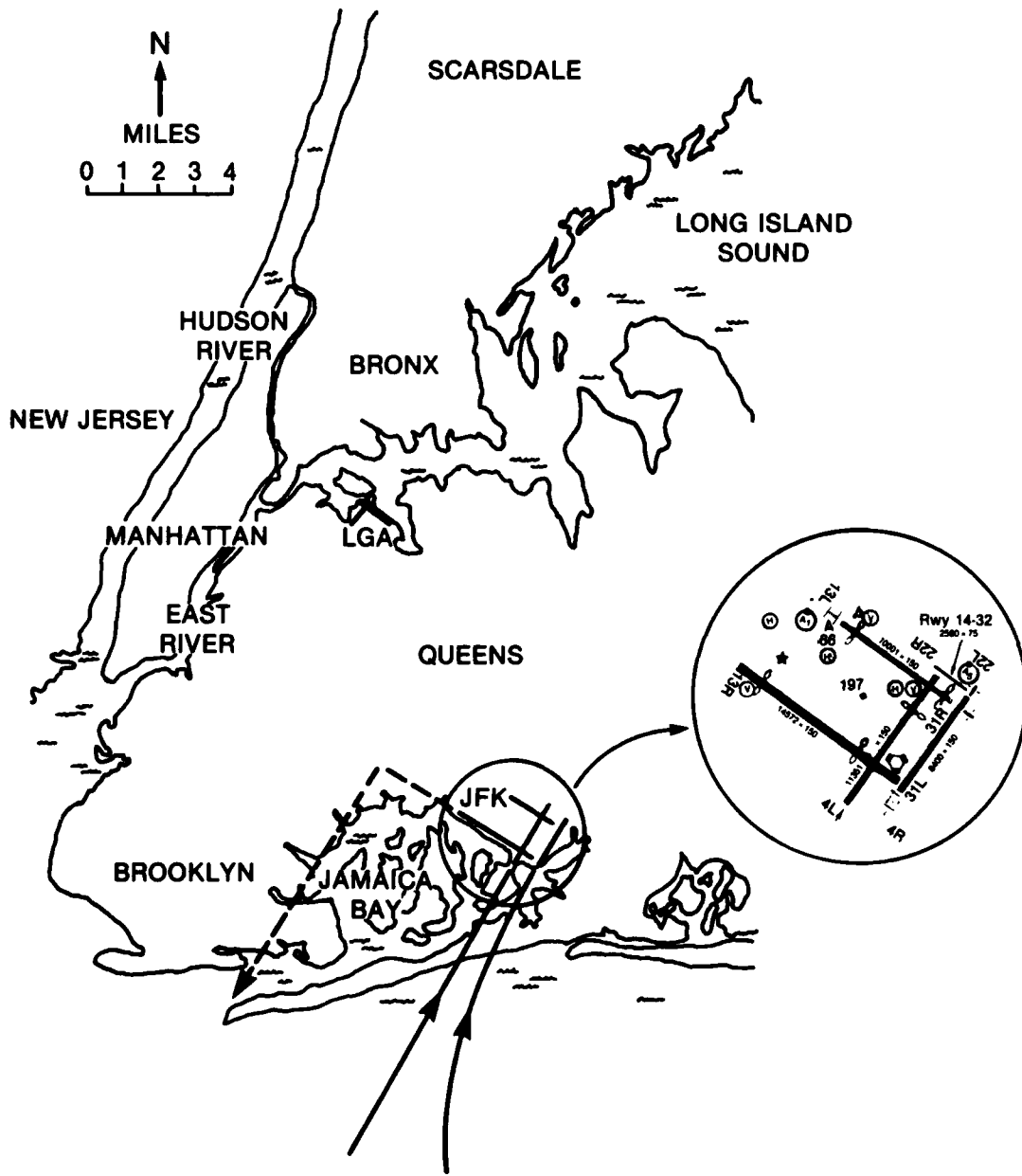

**FIGURE 6-1
SAMPLE APPLICATION AT JFK**

6.2 Sample Application of Almost-Parallel ILS Approaches - Memphis Airport

A potential application of almost-parallel ILS approaches can be found at Memphis (almost-parallel MLS approaches could also be applied). Runways 18R and 18L, and 36R and 36L are likely candidates for independent parallel operations. Figure 6-2 shows the parallel runway geometry at Memphis. There is a 3400 foot separation between runways and the thresholds are staggered. Both of these conditions are favorable in the sense that they involve a reduction in the minimum angle of offset required. In the case of staggered thresholds, offsetting the approach course to the runway that has the farthest-in threshold reduces the required angle of offset. For Memphis the required offset is only 1.1 degrees.

At Memphis, runway 36L has a CAT II ILS. Runways 36R, 18R, and 18L have CAT I ILSs. By offsetting the ILS on runway 36R, the ILS CAT II capability of runway 36L remains intact. Therefore, for Memphis, all conditions appear to be favorable.

6.3 Other U.S. Airports with Potential for Almost-Parallel Approaches (MLS or ILS)

In addition to New York's Kennedy and Memphis Airports discussed in sections 6.1 and 6.2, the following U.S. airports are potential candidates for the application of the almost-parallel concept (or other concepts that may allow independent IFR approaches to reduced-spacing parallel runways) (Reference 6): Phoenix (PHX), Minneapolis (MSP), Salt Lake City (SLC), Detroit (DTW), Fort Lauderdale (FLL), Portland (PDX), Dallas Love (DAL) and Raleigh-Durham (RDU). This list of applications includes only those airports with existing concrete. Future applications with new runways are certainly possible.

At Salt Lake City runways 16L and 16R are offset by 5 degrees and have staggered thresholds. This enables independent approaches under current conditions (no offset or different procedure is required). A blunder analysis has been performed and at all points along the final approach the separation between courses is larger than the minimum required for a safe blunder recovery.

7. ADVANTAGES AND DISADVANTAGES OF ALMOST-PARALLEL APPROACHES TO PARALLEL RUNWAYS

7.1 Parallel Versus Almost-Parallel Approaches to Parallel Runways

Analysis has shown that an improved surveillance system would be required to safely monitor independent IFR parallel approaches to parallel runways if the spacing between the runways is to be reduced significantly below 4300 feet. The principal advantage of the almost-parallel approach concept is that it would allow independent IFR approaches to these runways without requiring an improved surveillance system. If the concept is used it may result in substantial cost savings and a shorter implementation time than that required to develop and install an improved surveillance system.

There are several methods for implementing the almost-parallel concept that depend on the type of precision guidance system used. This paper has discussed procedures that would require the use of either MLS/Area Navigation (RNAV), MLS or ILS. The following sections present comparisons between the use of the three systems.

7.2 Comparison of MLS, MLS/RNAV and ILS as Applied to Almost-Parallel Approaches

7.2.1 MLS/RNAV Applications

MLS can be used to implement the almost-parallel concept by permitting offset straight-in approach courses or by using MLS/RNAV to permit curved or segmented approach courses.

The use of MLS/RNAV is the best alternative from a technical point of view. The principal technical advantage is that the last portion of the final approach course is aligned with the extended runway centerline and the aircraft is therefore on the centerline and provided with precision guidance all the way to the threshold. Consequently, properly equipped aircraft may be allowed to operate at decision heights of less than 200 feet.

A second advantage of the proposed procedures using MLS/RNAV is that at distances greater than 3 nmi from the threshold, there is more than 4300 feet between the two approach courses. Consequently, this allows the use of significantly wider Normal Operating Zones at these distances than could be achieved with straight-in approaches. This reduces the probability that an

aircraft will inadvertently enter the No Transgression Zone because of flight technical error thus making the procedure more reliable than parallel or almost-parallel offset approach courses.

A near-term problem of MLS/RNAV is that it requires adequate equipage within the fleet of aircraft using the airport. MLS/RNAV equipment may not be suitable for operators of smaller or older aircraft. However, the implementation procedures call for the use of MLS/RNAV on only one of the runways with standard precision guidance on the other. Consequently, the addition of an MLS/RNAV approach to one runway would allow independent approaches for the percentage of the IFR users that are properly equipped. Although MLS/RNAV is preferred from a technical standpoint, it will not be a cost effective alternative for parallel approaches until a significant portion of the IFR fleet is equipped with MLS/RNAV.

7.2.2 MLS Applications

The second implementation method using MLS would require that the MLS azimuth antenna be relocated to the side of the runway so that the final approach course would be offset from the runway centerline by 1 to 3 degrees. All MLS equipped aircraft would be able to use this precision guidance system. Although Terminal Instrument Procedures (TERPS) have not been developed for MLS offset approaches, if they were to follow those developed for ILS, the offset approach would require a minimum decision height of 250 feet. The final approach course would intersect the runway centerline about 3500 feet from the threshold at which point the pilot would transition from electronic to visual azimuth guidance.

The principal advantage of this method is that it would be available to all MLS users. Its principal disadvantages are that it may require a decision height of 250 feet or greater and that it requires visual azimuth guidance from the decision height to the threshold. A near-term disadvantage is that it must await the installation of MLS transmitters and receivers.

7.2.3 ILS Applications

The implementation of almost-parallel approaches using ILS is similar to that of offset MLS approaches. One runway would have its localizer offset by 1 to 3 degrees. The other runway would retain its conventional precision guidance. The offset runway would require a 250 foot decision height and precision

guidance would be lost at the point where the localizer intersects the extended runway centerline. As mentioned earlier, there are offset localizers in use at major airports today.

The principal advantage of ILS is that it is currently available. ILS has been in use for many years and the IFR fleet is almost totally equipped with ILS receivers. No additional equipment or training would be required of pilots or aircraft operators.

Its principal disadvantage is that implementation would require that one localizer antenna be repositioned to the side of the runway. This repositioning would permanently change the ILS approach course for that runway. With an offset of 3 degrees or less the decision height must be raised to 250 feet. Thus, all approaches to the offset localizer runway would be permanently limited to a 250 foot decision height. Azimuth guidance is lost at about 3/4 nmi from the threshold requiring visual guidance from that point to the threshold. This precludes the possibility of CAT II or III approaches (and also precludes the use of auto land capability) to the offset localizer runway. In addition, offsetting the localizer would prohibit its use for a back course approach.

8. SUMMARY AND CONCLUSIONS

Simultaneous independent approaches to parallel runways separated less than 4300 feet can be conducted by executing "almost-parallel" approaches with the use of MLS curved or MLS or ILS offset straight approaches. Almost-parallel approaches include curved paths where very shallow rates of turn are required and offset straight paths where the angle of offset is small. These almost-parallel or nonstraight-in approaches allow the use of current radars in independent IFR parallel operations to runways separated by 3000 feet. Specific almost-parallel procedures have been proposed but others are possible.

Pilot's loss of sight of the other approach course during curved approaches is not an issue because the required angle of bank is less than 2 degrees. Blunder resolution is also possible because the separation between aircraft provided by the almost-parallel procedures is larger than the minimum necessary for a safe blunder resolution according to current practices.

Some alternative implementation strategies exist and have been described for use during the transition period from ILS to MLS. During this period both systems need to be operational at the same time. Potential applications of the almost-parallel procedures have been shown for New York's Kennedy Airport and Memphis Airport.

There are issues that require further analysis and that have not been discussed in the preliminary concept analysis presented in this report. Among these issues are: the siting of antennas, the effects of the level of MLS equipage of different aircraft on the almost-parallel procedures and their benefits, the pilot's/autopilot's ability to fly very shallow curves (in the case of MLS curved approaches), the effects of a final turn on the aircraft's position with respect to the runway centerline prior to landing (in the case of offset MLS and ILS approaches), and the definition of missed approach procedures for offset straight approaches.

APPENDIX A

PROCEDURE TO CALCULATE RATES OF TURN AND ANGLES OF BANK

Rate of Turn

The following is the procedure used to calculate the aircraft rates of turn. Figure A-1 shows the geometry of the curved approaches to parallel runways and the parameters used to calculate the rate of turn necessary to execute these approaches.

$$w = \frac{V \times \theta}{C}$$

where:

w = rate of turn

V = Ground Speed

R = Turn Radius = $(a^2 + b^2)/2a$

C = Length of Arc During Turn

$\theta = C/R$

Example:

Runway Spacing = 3000 feet

Aircraft separation = 4300 feet implies a = 650 feet

Distance from threshold analyzed = 3 nmi implies b = 2 nmi

$$R = \frac{a^2 + b^2}{2a} = 113,918 \text{ feet}$$

$$\theta = \tan^{-1} \frac{b}{R-a} = 6.12 \text{ degrees} = 0.11 \text{ radians}$$

$$C = R\theta = 12,170 \text{ feet}$$

$$V = 236.3 \text{ ft/sec.}$$

$$\text{Rate of Turn} = \frac{V \times \theta}{C} = 0.12 \text{ degrees/sec.}$$

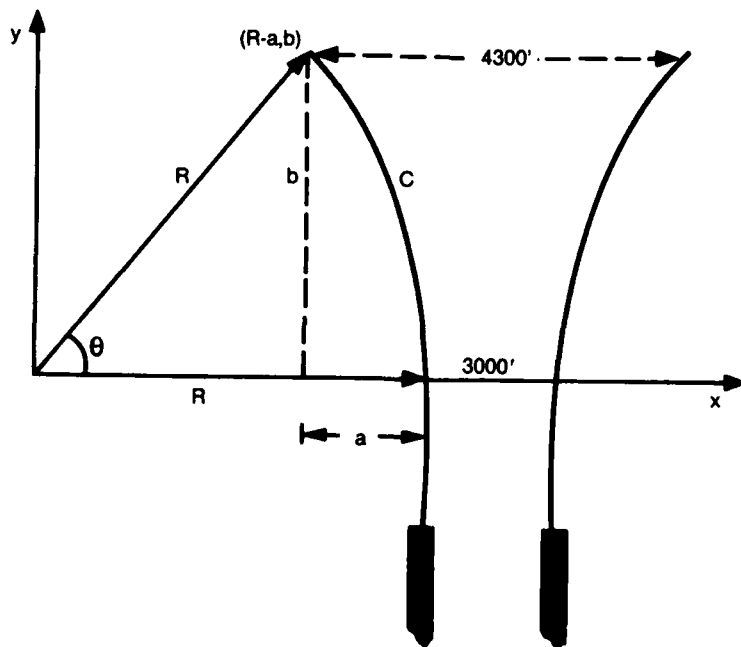

**FIGURE A-1
PROCEDURE TO CALCULATE RATES OF TURN**

Angle of Bank

$$\text{angle of bank} = \tan^{-1} \frac{wV}{g}$$

where g = acceleration due to gravity (32.2 ft/sec²)

For the proposed procedure of curved approaches to parallel runways:

$$w = \text{rate of turn} = 0.12 \text{ degrees/sec} = 2.1 \times 10^{-3} \text{ rad/sec}$$

$$v = \text{velocity} = 140 \text{ kts} = 236.3 \text{ ft/sec}$$

$$g = 32.2 \text{ ft/sec}^2$$

Then, the angle of bank is

$$\text{angle of bank} = \tan^{-1} \frac{(2.1 \times 10^{-3} \text{ rad/sec})(236.3 \text{ ft/sec})}{32.2 \text{ ft/sec}^2}$$

$$= 1.5 \times 10^{-2} \text{ rad}$$

$$\text{angle of bank} = 0.88 \text{ degrees}$$

APPENDIX B

BLUNDER ANALYSIS

B.1 CONCEPTS

The blunder analysis for almost-parallel approaches is based on the analysis for independent parallel IFR approaches (Reference 2). The only major change occurs in the analysis of the correction zone. In order to determine the minimum runway spacing which may be achieved, the parameters of the avoidance maneuver must be specified. A qualitative description of the analysis is given below. The total runway spacing is divided into five segments:

1. The Normal Operating Zone (NOZ) for the first runway which accounts for the error in the aircraft's ability to fly the nominal path (ILS centerline in the case of straight parallel approaches) due to the effects of navigation, aircraft, pilot and weather, and the ability of the controller and surveillance system to detect the aircraft's position.
2. A Detection Zone (DZ) which allows for the inaccuracy and delay in the process of actually determining that an aircraft has deviated outside of the NOZ.
3. A Delay Zone (DEL) which accounts for the loss in spacing between the two aircraft due to the continued movement of the blundering aircraft while the controller communicates with the nonblunderer.
4. A Correction Zone (CZ) which allows for the time for the evading aircraft to react to the turn command and achieve the desired course parallel to the violator.
5. A Miss Distance (MISS) which accounts for an adequate lateral separation between the two aircraft at their point of closest approach. It includes an allowance for navigation errors in the nonblunderer's course.

The detailed parameters necessary for the evaluation of the size of these zones are described below. The width of each of the five zones is determined using parameters whose values must be determined prior to the analysis. Choosing these values is called "calibrating" the model and the model has been calibrated so that at 9 nmi, 4300 feet is the minimum required spacing. A summary of the parameters is given in Table B-1.

TABLE B-1
INPUT PARAMETERS BY ZONE

Normal Operating Zone:

Alarm (Controller Intervention) Rate
Aircraft Position Error Distribution
Pilot
Aircraft
Navigation
Data Acquisition System Error Distribution
System
Controller

Detection Zone:

Worst-Case Violator Specification
Velocity
Deviation Angle
Data Acquisition System Update Interval
Data Acquisition System Error Distribution
System
Controller
Nondetection Rate

Delay Zone:

Worst-Case Violator Specification
Velocity
Deviation Angle
Total Delay Time
Controller
Communication
Pilot

Correction Zone:

Worst-Case Violator Specification
Velocity
Deviation Angle
Total Delay Time
Controller
Communication
Pilot
Aircraft
Evader Aircraft Turning Performance

Miss Distance:

Required Miss Distance
Aircraft Position Error Distribution
Pilot
Aircraft
Navigation

Normal Operating Zone: For safety purposes, it would be possible to establish nearly any value for the NOZ. However, if this value is too low, even normally operating aircraft would be identified as violators. Not only would this result in unnecessary avoidance maneuvers (and loss of capacity), but pilot confidence in the entire control process would be lost, with associated safety consequences. Thus, the NOZ must be large enough to ensure that the alarm rate (i.e., rate of identified violations) is sufficiently small. Parameter inputs to this process are:

1. Acceptable rate of alarms (i.e., controller intervention rate);
2. Distribution of errors of aircraft lateral position with respect to the nominal path. This depends both on aircraft/pilot characteristics and the navigation system. It is assumed that errors in lateral position with MLS are the same as those for ILS. Actually MLS is expected to reduce such errors; and
3. Distribution of errors in lateral position estimate of data acquisition (surveillance) system, to include controller error in reading data presented on his scope.

Detection Zone: The detection zone is sized so that a specified worst-case violator is identified as having crossed the NOZ by the time it is in fact no further from the nominal path than $NOZ + DZ$. This identification must occur by this point except for some (very small) percent of time. Parameter inputs to this calculation are:

1. Specification of worst-case violator (velocity and assumed constant angle of deviation from nominal path);
2. Data acquisition system update interval;
3. Error in measurement of lateral position (including those due to both the data acquisition system and to the controller's reading of his display); and
4. The probability of nondetection within the bounds of the DZ (e.g., 1 in 100). For the analysis of the curved approaches the probability of nondetection at 3 nmi has been assumed equal to that at 9 nmi. This is a conservative assumption because the surveillance error decreases and, therefore, the probabilities of detecting an aircraft are greater.

Delay Zone and Correction Zone: The delay zone and the correction zone are sized to account for the delay time between the detection of the violator by the controller, through message transmission to the pilot, to the initiation of aircraft response; as well as the distance needed during the maneuver by the evading aircraft. The latter accounts for the spacing required by the violator's continued track, less the lateral spacing increase experienced by the evading aircraft as it completes the turn to a course parallel to the violating aircraft. Parameter inputs to this calculation are:

1. Specification of worst-case violator (as above);
2. Total delay time (communication channel access, transmission, pilot reaction); and
3. Aircraft turning performance.

For curved approaches the Correction Zone changes compared to straight-in parallel approaches because of the curvature of the course. A detailed derivation follows in Section B.2.

Miss Distance: At the completion of the evasive maneuver under the worst-case conditions there must be an adequate lateral separation between aircraft. This must also account for the possibility that the evading aircraft may not have been exactly on the nominal path. No altitude separation is assumed. The nonblundering aircraft is assumed to be flying at zero angle deviation and 3 standard deviations off the centerline towards the blundering aircraft. Parameter inputs to this calculation are:

1. Required lateral miss distance (longitudinal separation may be present, but is not assumed); and
2. Distribution of errors of aircraft lateral position with respect to the nominal path. This depends upon both aircraft/pilot characteristics and navigation system. It is assumed that MLS navigation accuracy is at least as good as ILS navigation accuracy.

B.2 DERIVATION OF THE CORRECTION ZONE

The NOZ, DZ, DEL, and MISS are the same in both the normal straight-in parallel approach case and the almost-parallel approach case. This is not true for the correction zone. The derivation of the CZ for the straight-in parallel and the curved almost-parallel cases is shown below. Table B-2 shows the definition of the parameters used.

TABLE B-2
INPUT/OUTPUT PARAMETER DEFINITIONS

INPUT

ANGLE1	Angle of Blunder
ANGLE2	Additional Angle of Turn by Nonblunderer During Curved Approach
VELONE	Velocity of Blunderer
VELTWO	Velocity of Nonblunderer
COR	Rate of Turn for the Nonblunderer

OUTPUT

NOZ	Normal Operation Zone
DZ	Detection Zone
DEL	Delay Zone
CA	Loss in Separation by Blunderer During Correction
CB	Gain in Separation by Nonblunderer During Correction
CZ	Net Separation Loss or Correction Zone (= CA - CB)
MISS	Total Miss Allowance (= MD + NB)
RS	Runway Spacing

1. CZ for the normal straight-in parallel approaches:

The correction zone is made up of two quantities (CA and CB). The first is the additional space the blunderer travels during the process of correction (or avoidance) by the nonblundering aircraft.

The time for the nonblundering aircraft to turn to a parallel course is

$$\frac{\text{ANGLE1}}{\text{COR}}$$

During this time, the blundering aircraft travels a distance CA towards the other approach course, where:

$$\text{CA} = \text{ANGLE1} * \text{VELONE} * \text{SIN}(\text{ANGLE1}) / \text{COR}$$

This distance, CA, is partially offset by an increase in spacing (CB) because the nonblundering aircraft is turning away to a parallel course. The geometry of this corrective turn is illustrated in Figure B-1.

The radius of turn (R) is

$$R = \frac{\text{VELTWO}}{\text{COR}}$$

and the relationship

$$\text{COS}(\text{ANGLE1}) = \frac{R - \text{CB}}{R}$$

yields

$$\text{CB} = R * (1 - \text{COS}(\text{ANGLE1}))$$

CA and CB yield CZ from the relationship:

$$\text{CZ} = \text{CA} - \text{CB}$$

2. CZ for the almost-parallel curved approaches:

In the curved approach case shown in Figure B-2, the blunderer travels an additional distance before the nonblundering aircraft reaches a parallel course. This is because the nonblunderer has to turn ANGLE1 (angle of blunder) plus ANGLE2 (additional angle).

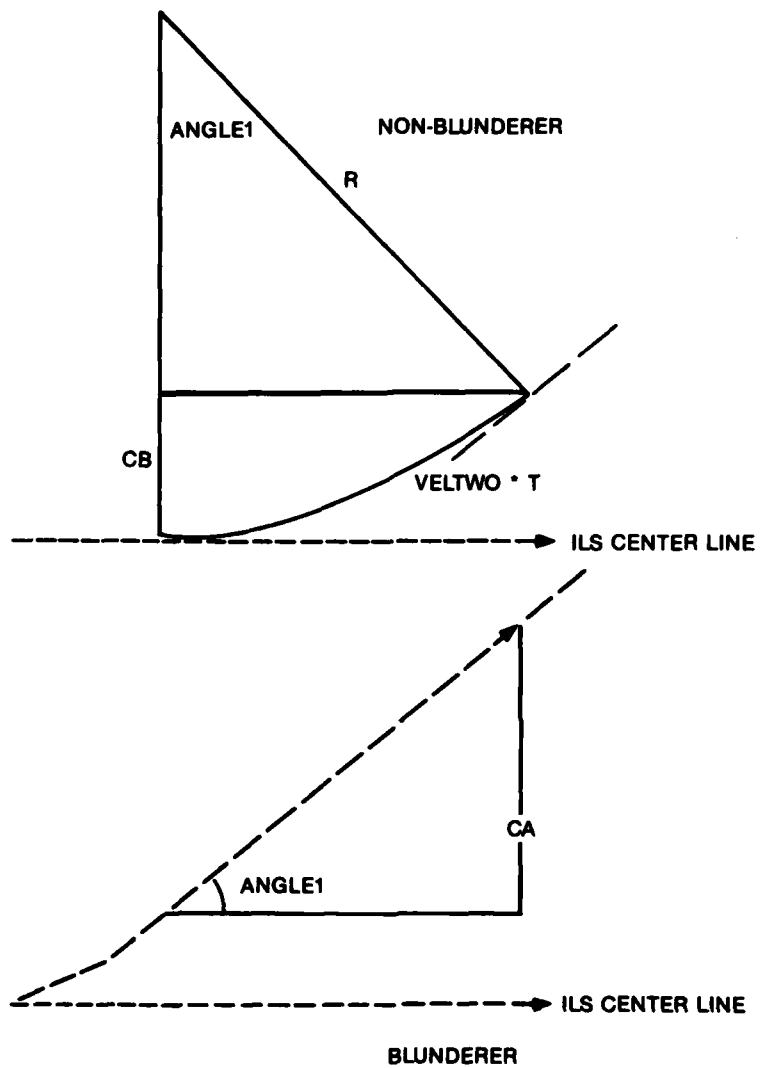

**FIGURE B-1
 GEOMETRY OF CORRECTIVE TURN FOR
 STRAIGHT-IN PARALLEL APPROACHES**

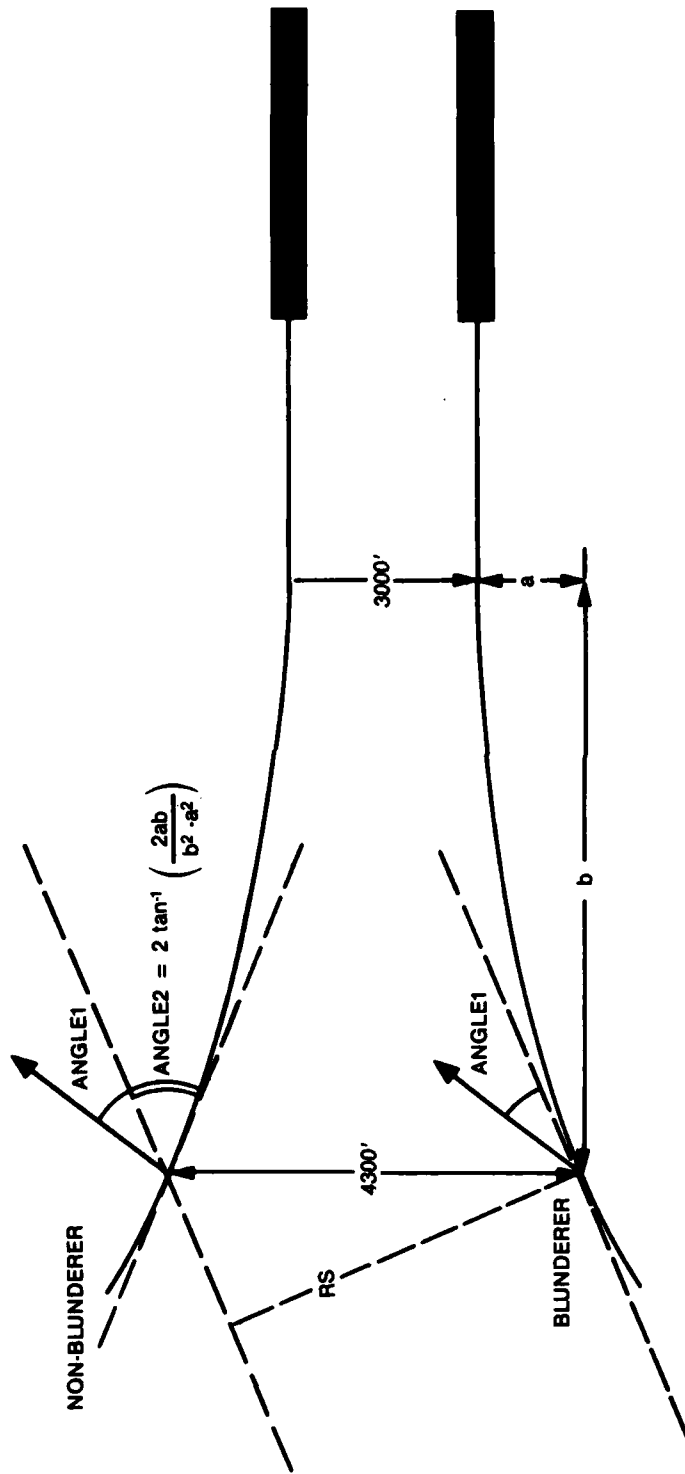

FIGURE B-2
CURVED APPROACH CASE

ANGLE2 is the difference between the headings of the two approach courses at the point where the blunder begins. From Figures A-1 and B-2 it can be seen that ANGLE2 is equal to 2θ and,

$$\text{ANGLE2} = 2 \tan^{-1} \frac{2ab}{b^2 - a^2}$$

where:

$b = (\text{distance from threshold}) - (\text{straight flight distance})$

$a = 1/2 * [(\text{separation at } b) - (\text{runway spacing})]$

(In the offset straight case ANGLE2 is a fixed value.)

The additional distance due to ANGLE2 is

$$\text{ANGLE2} * \text{VELONE} * \text{SIN}(\text{ANGLE1}) / \text{COR}$$

Then

$$\begin{aligned} \text{CA} &= \text{ANGLE1} * \text{VELONE} * \text{SIN}(\text{ANGLE1}) / \text{COR} \\ &+ \text{ANGLE2} * \text{VELONE} * \text{SIN}(\text{ANGLE1}) / \text{COR} \end{aligned}$$

$$\text{CA} = \frac{\text{VELONE} * \text{SIN}(\text{ANGLE1}) * (\text{ANGLE1} + \text{ANGLE2})}{\text{COR}}$$

CB is the same as in the straight-in parallel case:

$$\text{CB} = R * (1 - \text{COS}(\text{ANGLE1}))$$

and,

$$\text{CZ} = \text{CA} - \text{CB}$$

The required spacing between runways in the straight-in parallel case is computed from the sum of these components:

$$\text{RS} = \text{NOZ} + \text{DZ} + \text{DEL} + \text{CZ} + \text{MISS}$$

In the straight-in parallel case ANGLE2 is equal to zero. However, for the curved paths the minimum distance between runways is RS' and calculated from:

$$\text{RS}' = (\text{NOZ} + \text{DZ} + \text{DEL} + \text{CZ} + \text{MISS}) / \text{COS}(\text{ANGLE2}/2)$$

B.3 NUMERICAL ASSUMPTIONS AND CALCULATIONS

The following are the numerical assumptions (inputs) used in the calculation of minimum runway spacings:

1. Aircraft velocities (blunderer and nonblunderer): 140kts
2. Angle of blunder: 30 degrees
3. Controller intervention rate: 2×10^{-4}
4. Delay time: 8 seconds
5. Miss distance: 200 feet
6. Navigation buffer: 3 sigma
7. Navigation error at 3 nmi from threshold (blunderer and nonblunderer): 82 feet
8. Nondetection probability: 10^{-2}
9. Rate of turn: 3 degrees/second
10. Surveillance error: 30.4 feet/nmi
11. Surveillance update: 4 seconds

The inclusion of the above numerical assumptions in the mathematical expressions for each zone yield the results presented in Table B-3. This table analyzes the allowed and actual separations between aircraft during almost-parallel curved approaches starting at the point where the 4300 foot separation is lost until the point where both paths become parallel and lined-up with the runway centerlines.

It is clear from Table B-3 that at all points on the curved approaches the separations established by the proposed procedure are larger than the allowed minimums. Furthermore, the obtained minimum runway spacings are conservative since ILS (not MLS) accuracies were assumed and the value of the navigation error was kept constant (at a value corresponding to 3 nmi from the threshold) for all points when in reality the error decreases at points closer to the runway threshold.

TABLE B-3
 REQUIRED AND ACTUAL SEPARATIONS
 DURING ALMOST-PARALLEL CURVED APPROACHES

DISTANCE FROM THRESHOLD (nmi)	MINIMUM ALLOWABLE SEPARATIONS USING TODAY'S RADAR (FEET)					ACTUAL SEPARATION FOR CURVED PATHS (FEET)
	NOZ	DZ	DEL	CZ	MISS	
3.0	519	638	945	1059	446	4300
2.5	476	612	945	938	446	3730
2.0	434	586	945	817	446	3324
1.5	396	560	945	697	446	3081
1.0	361	535	945	577	446	3000

APPENDIX C

ACRONYMS

ATC	Air Traffic Control
CZ	Correction Zone
DAL	Dallas Love
DEL	Delay Zone
DTW	Detroit
DZ	Detection Zone
FAA	Federal Aviation Administration
FLL	Fort Lauderdale
GA	General Aviation
IFR	Instrument Flight Rules
ILS	Instrument Landing System
JFK	John F. Kennedy International Airport
kts	Knots
m	Meters
MISS	Miss Distance
MLS	Microwave Landing System
MSP	Minneapolis
NASCOM	National Aviation System Communications Staff
nmi	Nautical Miles
NOZ	Normal Operating Zone
PDX	Portland
PHX	Phoenix

ACRONYMS
(Concluded)

Rad	Radians
RDU	Raleigh-Durham
RNAV	Area Navigation
Sec	Seconds
SLC	Salt Lake City

APPENDIX D

REFERENCES

1. A. L. Haines, R. M. Harris, and A. N. Sinha, "Operational Techniques for Increasing Airport Capacity", MP-82W24, The MITRE Corporation, October 1982.
2. A. L. Haines and W. J. Swedish, "Requirements for Independent and Dependent Parallel Instrument Approaches at Reduced Runway Spacings", FAA-EM-81-8, The MITRE Corporation, May 1981.
3. Federal Aviation Administration, "Air Traffic Control", Order 7110.65D, October 1984 (Updated June 1985).
4. A. L. Haines, R. M. Harris, and A. N. Sinha, "Operational Concepts for Multiple Instrument Approaches", MP-82W1, The MITRE Corporation, May 1982.
5. Department of Transportation, "United States Standard for Terminal Instrument Procedures (TERPS), Third Edition", FAA Handbook 8260.3B, July 1976.
6. A. C. Silva and J. N. Barrer, "Potential Applications of Multiple Instrument Approach Concepts at 101 U.S. Airports", FAA-DL5-85-2 (MTR-85W65), The MITRE Corporation, September 1985.

ENND

Dtjic

5-86