

AD-A167 483

INDIAN ISLAND MOORINGS PHASE II PROJECT EXECUTION PLAN
(U) NAVAL FACILITIES ENGINEERING COMMAND WASHINGTON DC
CHESAPEAKE DIV 22 JUL 83 CHES/NAVFAC-FPO-8302.5

1/1

UNCLASSIFIED

F/G 13/2

NL



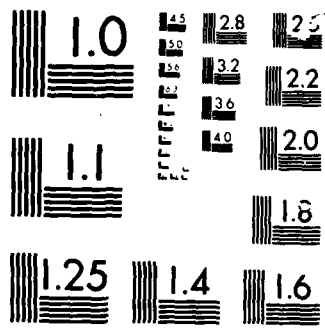

MICROCOPY

CHART

FPO
S302.5

AD-A167 483



DTIC
SELECTE
MAY 02 1986
S D
D W

INDIAN ISLAND MOORINGS
PHASE II

PROJECT EXECUTION PLAN

22 JULY 1983

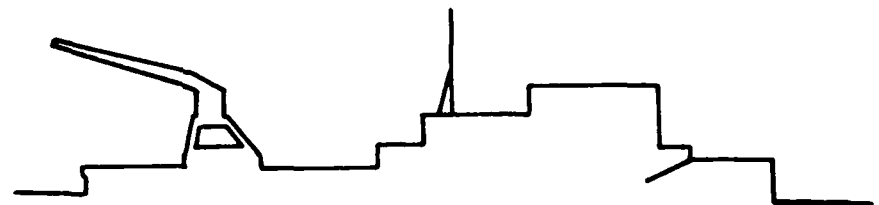

Ocean Engineering

CHESAPEAKE DIVISION
NAVAL FACILITIES ENGINEERING COMMAND
WASHINGTON NAVY YARD
WASHINGTON, DC 20374

DTIC FILE COPY

DISTRIBUTION STATEMENT A
Approved for public release
Distribution Unlimited

86 4 22 105

2

INDIAN ISLAND MOORINGS
PHASE II

PROJECT EXECUTION PLAN

22 JULY 1983

DISTRIBUTION STATEMENT A
Approved for public release
Distribution Unlimited

DTIC
ELECTE
MAY 02 1986
S D
D

Unclassified
SECURITY CLASSIFICATION OF THIS PAGE

ADA 167483

REPORT DOCUMENTATION PAGE

1a. REPORT SECURITY CLASSIFICATION
Unclassified

1b. RESTRICTIVE MARKINGS

2a. SECURITY CLASSIFICATION AUTHORITY

3. DISTRIBUTION AVAILABILITY OF REP.
Approved for public release;
distribution is unlimited

2b. DECLASSIFICATION/DOWNGRADING SCHEDULE

4. PERFORMING ORGANIZATION REPORT NUMBER
FPO 8302.5

5. MONITORING ORGANIZATION REPORT #

6a. NAME OF PERFORM. ORG. 6b. OFFICE SYM
Ocean Engineering
& Construction
Project Office
CHESNAVFACENGCOM

7a. NAME OF MONITORING ORGANIZATION

6c. ADDRESS (City, State, and Zip Code)
BLDG. 212, Washington Navy Yard
Washington, D.C. 20374-2121

7b. ADDRESS (City, State, and Zip)

8a. NAME OF FUNDING ORG. 8b. OFFICE SYM

9. PROCUREMENT INSTRUMENT IDENT #

8c. ADDRESS (City, State & Zip)

10. SOURCE OF FUNDING NUMBERS

PROGRAM ELEMENT #	PROJECT #	TASK #	WORK UNIT ACCESS #
-------------------	-----------	--------	--------------------

11. TITLE (Including Security Classification)
Indian Island Moorings Phase II

12. PERSONAL AUTHOR(S)

13a. TYPE OF REPORT

13b. TIME COVERED
FROM TO

14. DATE OF REP. (YYMMDD) 15. PAGES
83-07-22 28

16. SUPPLEMENTARY NOTATION

17. COSATI CODES
FIELD GROUP SUB-GROUP

18. SUBJECT TERMS (Continue on reverse if nec.)
Mooring inspections, Indian Island

19. ABSTRACT (Continue on reverse if necessary & identify by block number)
The Naval Undersea Warfare Engineering Station (NUWES), Keyport, WA has the requirement for six fleet moorings at Indian Island, WA to secure YC and YFN ammunition barges. In January 1979, CHESNAVFACENGCOM installed Phase I, consisting of moorings number 1, 2, & 6. Details of the Phase I are in (Con't)

20. DISTRIBUTION/AVAILABILITY OF ABSTRACT 21. ABSTRACT SECURITY CLASSIFICATION
SAME AS RPT.

22a. NAME OF RESPONSIBLE INDIVIDUAL
Jacqueline B. Riley
DD FORM 1473, 84MAR

22b. TELEPHONE 22c. OFFICE SYMBOL
202-433-3881
SECURITY CLASSIFICATION OF THIS PAGE

BLOCK 19 (Con't)

included "Indian Island Mooring Installation Project Completion Report.

In April 1982, CHESNAVFACENGCOM was tasked to design and install the remaining three moorings. As part of this effort, CHESNAVFACENGCOM conducted an underwater diver inspection of the three existing moorings. We determined that mooring number 1 had been displaced approximately 140 feet from its installed location.

Phase II, the installation of moorings number 3, 4, and 5, is scheduled for FY 83. Repair of mooring number 1 will also occur during this operation.

CONTENTS

	<u>Page No.</u>
1.0 PROJECT DESCRIPTION	1
1.1 Background	1
1.2 Work Scope	1
1.3 Project Tasking	1
2.0 PROJECT RESPONSIBILITIES	3
2.1 CHESNAVFACENCOM	3
2.2 Washington State National Guard, Takoma, WA (WSNG)	4
2.3 PSNS	4
2.4 UCT TWO	5
2.5 NUWES Keyport Det Indian Island (Indian Island)	6
3.0 CONSTRUCTION SCHEDULE	6
3.1 Preparation/Assembly of Project Equipment (Prior to 8 August 1983)	6
3.2 Transport of Project Equipment (18-20 August 1983)	7
3.3 Barge Set Up, Transit to Indian Island and On Site Mobilization (21-22 August 1983)	7
3.4 Install Moorings Number 4 and 5 (23-26 August 1983)	7
3.5 Recovery and Reinstallation Mooring Number 1 (27-29 August 1983)	7
3.6 Pull-Test Mooring Number 1 (30 August 1983)	8
3.7 Install Mooring Number 3 (31 August - 1 September 1983)	8
3.8 Pull-Test New Moorings (2 September 1983)	8
3.9 Clean Up and Transit Home (3 September 1983)	8
4.0 MOORING NUMBER 1 RECOVERY	8
5.0 TYPICAL MOORING INSTALLATION	9
5.1 Rig for Mooring Installation	9
5.2 Install Marker Buoys	9
5.3 Install The Mooring	12
5.4 Diver Inspection	16
5.5 Second Stage of Installation	16

CONTENTS (Continued)

	<u>Page No.</u>
6.0 FACILITY ACCEPTANCE TEST	16
6.1 Diver Inspection	17
6.2 Verification of Mooring Location	17
6.3 Pull-Test	17
6.4 Recovery of Crown Lines	19

Appendices

A	References	A-1
B	Design Data	B-1
C	Navigation Coordinates	C-1

Accession For	
NTIS CRA&I	<input checked="" type="checkbox"/>
DTIC TAB	<input type="checkbox"/>
Unannounced	<input type="checkbox"/>
Justification	
By	
Distribution /	
Availability Codes	
Dist	Avail and/or Special
A-1	

QUALITY INSPECTED
3

1.0 PROJECT DESCRIPTION

1.1 Background

The Naval Undersea Warfare Engineering Station (NUWES), Keyport, WA has the requirement for six fleet moorings at Indian Island, WA to secure YC and YFN ammunition barges. In January 1979, CHESNAVFACENGCOM installed Phase I, consisting of moorings number 1, 2, and 6 (see Figure 1-1). Details of the Phase I are included in "Indian Island Mooring Installation Project Completion Report," reference (a).

In April 1982, CHESNAVFACENGCOM was tasked to design and install the remaining three moorings. As part of this effort, CHESNAVFACENGCOM conducted an underwater diver inspection of the three existing moorings. We determined that mooring number 1 had been displaced approximately 140 feet from its installed location.

Phase II, the installation of moorings number 3, 4, and 5, is scheduled for FY 83. Repair of mooring number 1 will also occur during this operation.

1.2 Work Scope

The new moorings will utilize Class E components provided by NUWES. Subsequently, CHESNAVFACENGCOM modified the design to comply with site characteristics and performance requirements. Appendices B and C present a more detailed discussion of the requirements and designs.

1.3 Project Tasking

On 28 April 1982, CHESNAVFACENGCOM was requested by Western Division, Naval Facilities Engineering Command (WESTNAVFACENGCOM) to revise the moorings' designs and manage their installation including procurement of all required materials per reference (b). In reference (c), Commander, Naval Facilities Engineering Command (COMNAVFACENGCOM) informed WESTNAVFACENGCOM that it would provide all necessary funds for the design and installation. On 3 June 1983, CHESNAVFACENGCOM accepted the tasking via reference (d).

The three existing moorings were inspected by CHESNAVFACENGCOM as part of the Fleet Mooring Maintenance Program on 8-10 November 1982. Reference (e) from CHESNAVFACENGCOM to NUWES described the unsatisfactory condition of mooring number 1. In reference (f), NUWES requested CHESNAVFACENGCOM redesign the mooring to withstand larger loads. Further, it was requested that mooring number 1 be repaired during the August 1983 installation of Phase II.



OCEAN ENGINEERING AND CONSTRUCTION PROJECT OFFICE

POSITION OF THE MOORINGS

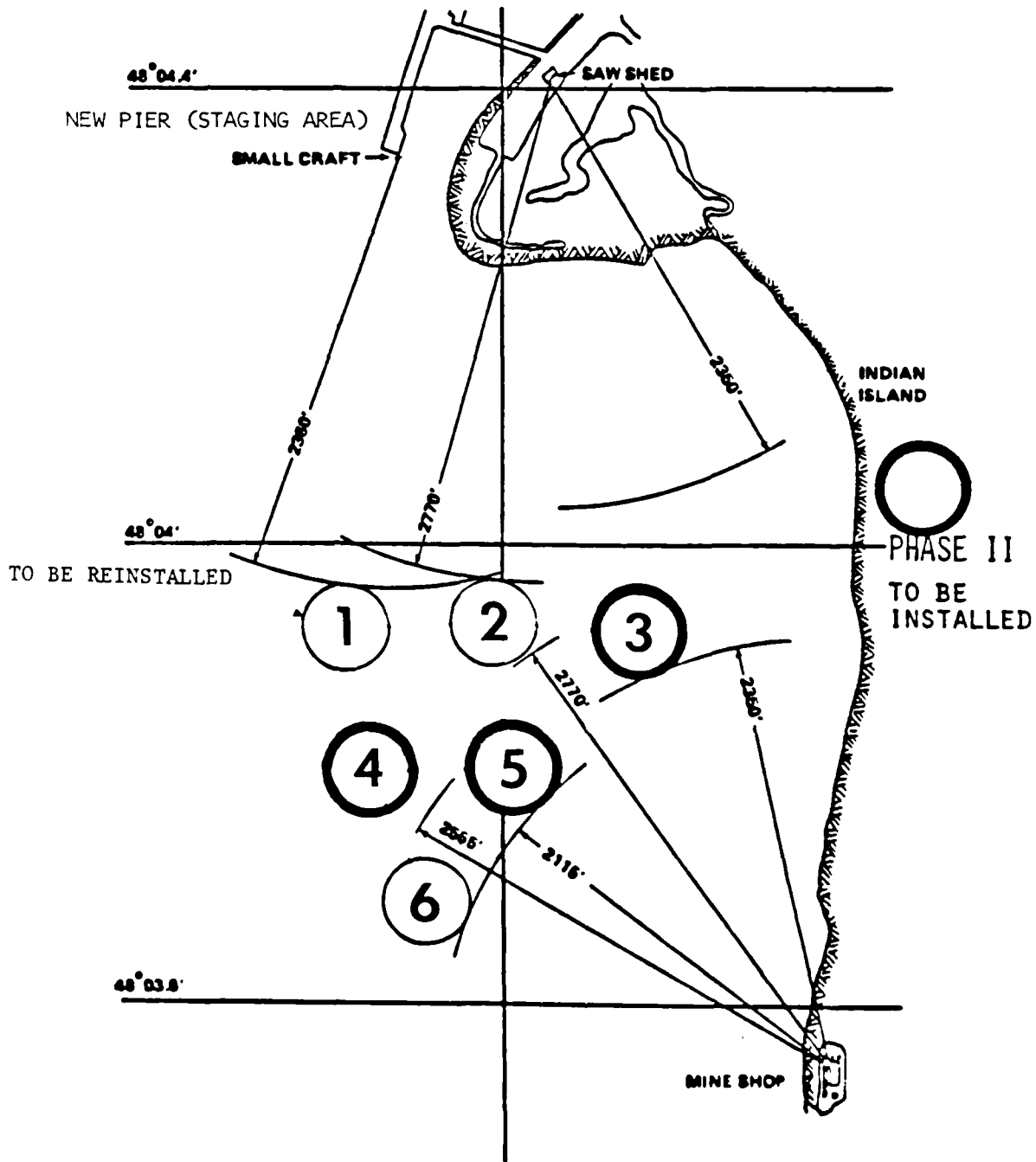

Figure 1-1

On 13 January 1983, CHESNAVFACENGCOM requested tug boat and crane barge services from the 144th Transportation Battalion, Washington State Army Reserve National Guard (WSNG) via reference (g). WSNG agreed to provide the above support via reference (h) on 22 May 1983.

On 4 February 1983, UCT TWO requested funds for diver support in reference (i). CHESNAVFACENGCOM provided this to COMCBPAC, Pearl Harbor the same day, via reference (j).

CHESNAVFACENGCOM, on 25 March 1983, in reference (k), requested Puget Sound Naval Shipyard (PSNS), Bremerton to:

- (1) Install tension bars in and refurbish three Mark II Peg Top Buoys,
- (2) Install stabilizers on three 25,000 lb. anchors, and
- (3) Provide riggers and rigging equipment.

PSNS received funding on 17 May via reference (l) from WESTNAVFACENGCOM.

2.0 PROJECT RESPONSIBILITIES

2.1 CHESNAVFACENGCOM

- o Provide overall project direction for mooring design and installation.
- o Coordinate project execution with NUWES.
- o Develop a mooring design using components of Class E, Free-Swinging, Riser Type Moorings, provided by NUWES Det. Indian Island which meets the user's performance requirements.
- o Redesign mooring number 1 to withstand a higher anticipated load.
- o Identify and coordinate modification and/or refurbishment of mooring materials.
- o Identify and coordinate assembly of construction platforms, equipment and personnel.
- o Provide project logistics, planning and engineering support.
- o Provide construction quality control and define/execute a Facility Acceptance Test.

- o Provide Mini-Ranger navigation equipment and services.
- o Provide photographic equipment and personnel to document construction operations.
- o Provide field engineering and design support.
- o Provide communications equipment.
- o Prepare a Project Execution Plan.
- o Prepare a Project Completion Report and as-built drawings.

2.2 Washington State National Guard, Tacoma, WA (WSNG)

- o Provide a 60-ton crane barge with two tugs and crews required for construction operations.
- o Provide for the safety of all personnel and equipment aboard these platforms during the construction mobilization period.
- o Perform all necessary modification/outfitting of these platforms to make them ready for construction operations.
- o Receive project equipment and make ready for transport to and from Indian Island aboard the WSNG barge or tugs.
- o Provide the following additional project equipment/services in support of construction operations:
 - Platform maneuvering and station-keeping
 - Crane operator
 - On-load mooring components and assist with rigging
 - Fathometer aboard the 100-foot tug
 - Batteries for Mini-Ranger transponders

2.3 PSNS

- o Fabricate and install tension bars in three each MK II Peg Top Buoys.
- o Refurbish three each MK II Peg Top Buoys.

- o Provide three each 25K anchors and fabricate and install stabilizers.
- o Provide five wharfbuilders to perform all deck operations, including rigging and mooring installations.
- o Provide for the safety of all personnel and equipment on deck during rigging and installation operations.
- o Identify and fabricate, or provide for, all rigging hardware, tools and equipment necessary for installing the moorings using the WSNB crane barge.
- o Provide a welder and associated hardware/equipment during construction operations.
- o Transport buoys, anchors and PSNS equipment to Indian Island.
- o Coordinate with CHESNAVFACENCOM for all PSNS supplied equipment and services.
- o Provide the following additional project equipment/services in support of construction operations:
 - Calibrated load cell and rigging necessary for the pull-test
 - Portable arc welder and associated hardware/equipment
 - Rigging for marker buoy moorings
 - Assistance with on-site logistics

2.4 UCT TWO

- o Provide a Navy dive team and services for underwater inspections and other construction operations.
- o Provide for the safety of all personnel and equipment used for diving operations, including medical evacuation and use of a recompression chamber.
- o Provide all dive equipment and a dive boat.
- o Provide a truck with drivers to transport diving equipment. Prepare for transport and coordinate movement and delivery of equipment to Indian Island and return.

- o Assist with deck operations under the supervision of the foreman wharfbuilder.
- o Assist with logistics and construction operations.
- o Provide transits for back-up navigation.
- o Provide wire cutters for use by divers.
- o Provide hand-held radios.

2.5 NUWES Keyport Det Indian Island (Indian Island)

- o Provide a standby tug.
- o Provide logistic support as needed.
- o Provide access to work sites.
- o Provide for secure equipment/material storage areas.
- o Provide barges for material storage.

3.0 CONSTRUCTION SCHEDULE

The following lists the daily sequence of events scheduled for the construction period, 18 August - 3 September 1983. This plan calls for a total of 17 days mobilization. No contingency has been added for possible heavy weather and unforeseen conditions. This schedule is subject to revision during the construction period.

3.1 Preparation/Assembly of Project Equipment (Prior to 18 August 1983)

CHESNAVFACENGCOM -

- o Assemble and ship navigation equipment to Indian Island.

WSNG -

- o Attach padeyes and prepare barge deck for project.
- o Continue preparation for receiving equipment and transit to Indian Island.
- o Assemble hardware/equipment in support of project.

PSNS -

- o Fabricate and install tension bars in three each MK II Peg Top Buoys.

- o Refurbish three each MK II Peg Top Buoys.
- o Fabricate and install stabilizers on three each 25K anchors.
- o Fabricate and/or assemble all welding and rigging hardware for project execution.
- o Tow barge containing buoys, anchors and PSNS equipment from Bremerton to Indian Island.

UCT TWO - o Prepare diving equipment and other hardware/equipment in support of project for transport to Indian Island.

3.2 Transport of Project Equipment (18-20 August 1983)

- o Construction team make final preparation for mobilization.

3.3 Barge Set Up, Transit to Indian Island and On Site Mobilization (21-22 August 1983)

- o Barge/tugs transit to Indian Island.
- o Remainder of construction team transit to Port Townsend.
- o On site inspection between CHESNAVFACENCOM/PSNS/WSNG/UCT TWO and follow-up discussion.
- o Set up Mini-Ranger navigation.
- o Weld flukes and anchors and other pre-rigging of mooring components.

3.4 Install Moorings Number 4 and 5 (23-26 August 1983)

- o Set up range markers.
- o Install two new moorings.
- o See Section 5.0 for detailed discussion on mooring installation.

3.5 Recover and Reinstall Mooring Number 1 (27-29 August 1983)

- o Recover mooring, see Section 4.0.
- o Set up ranger markers.
- o Install mooring number 1, see Section 5.0.

3.6 Pull-Test Mooring Number 1 (30 August 1983)

- o See Section 6.0 Facility Acceptance Test.

3.7 Install Mooring Number 3, (31 August - 1 September 1983)

- o Set up markers.
- o Install new mooring.
- o See Section 5.0 Typical Mooring Installation for a more detailed discussion.

3.8 Pull-Test New Moorings (2 September 1983)

- o See Section 6.0 Facility Acceptance Test.

3.9 Clean-Up and Transit Home (3 September 1983)

- o After the four moorings have been installed and the acceptance tests completed, all project equipment will be disassembled and prepared for transport.

4.0 MOORING NUMBER 1 RECOVERY

The following describes the various operations planned for the recovery of mooring number 1. Refer to Section 5.0 for details of a typical mooring installation. The sequence and duration of each operation must be considered approximate since they will depend upon the experience gained by the crew and the conditions encountered.

The intent is to minimize re-rigging of the chain for reinstallation.

- o Tug will maneuver the crane barge alongside buoy number 1.
- o The divers will attach a line from the crane hook to leg A on or near the bottom.
- o The crane will lift the leg chain until 90 feet of leg A below the ground ring is out of the water.
- o The leg will be stoppered-off on deck and the chain from the ground ring will be let back into the water.
- o The crane/tug will then work its way out towards anchor A lifting the chain and anchor onto the deck.

- o The tug will then maneuver the crane back to the buoy where leg 2 will be recovered in a similar fashion as leg 1.
- o Once two legs have been removed 90 feet below the ground ring, the tug will maneuver the crane back to the buoy to recover the remainder of the mooring.
- o The crane will lift the buoy with one anchor leg and two 90-foot legs onto the deck.
- o The tug/crane will proceed towards anchor 3 recovering the ground leg and anchor.
- o Disconnect original anchors and off-load. On-load modified 25K anchors.

5.0 TYPICAL MOORING INSTALLATION

The following describes the operations planned for the installation and test of each of the four moorings. Moorings number 1, 4, and 5 are all on flat bottoms. Therefore, their installation shall be very similar. Mooring number 3 is in shallower water and its legs will rest on a submerged hill. For this reason, the installation of number 3 will be performed last in order to best utilize the experience gained from the proceeding three installations.

5.1 Rig for Mooring Installation

The crane barge will be positioned at the pier with its stern alongside the two storage barges. Operating over its stern, the crane barge will on-load the components and lay them out on deck. The components will be assembled and stoppered-off on deck as shown in Figure 5-1. All preparations will be made for executing installation the following morning.

5.2 Install Marker Buoys

The Mini-Ranger will be located on the 45-foot tug used to maneuver the crane barge. Concurrent with the rigger operations, the tug will be maneuvered to the location specified for each marker buoy and the buoys deployed. The intent is to provide a marker buoy that will tend directly over its anchor and not be submerged during high tide conditions.

A total of six buoys will be deployed, i.e., two location buoys and two pairs of range-bearing buoys (see Figure 5-2). The two location buoys will mark the sites of the mooring buoy (center of the mooring) and the anchor for leg number 1. The two pairs of range-bearing buoys will indicate the direction/bearing in which leg number 2 and leg number 3 are to be layed. These buoys will be positioned approximately 300 feet out from the anchor sites to provide room for the barge/tugs to maneuver.

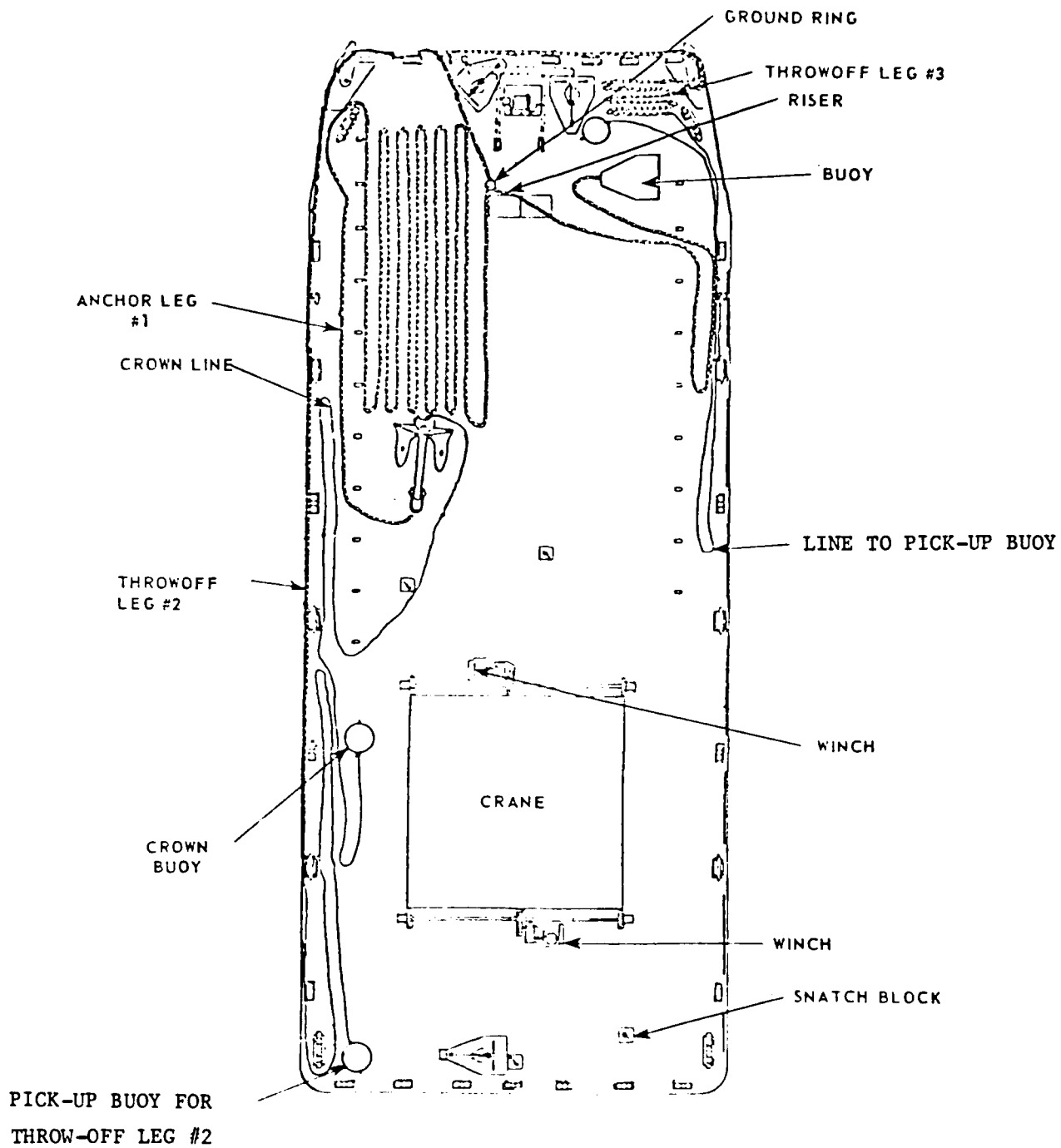

INITIAL LAYOUT OF EQUIPMENT FOR THE
FIRST LEG OF THE MOORING.

Figure 5-1



OCEAN ENGINEERING AND CONSTRUCTION PROJECT OFFICE

INDIAN ISLAND MOORINGS

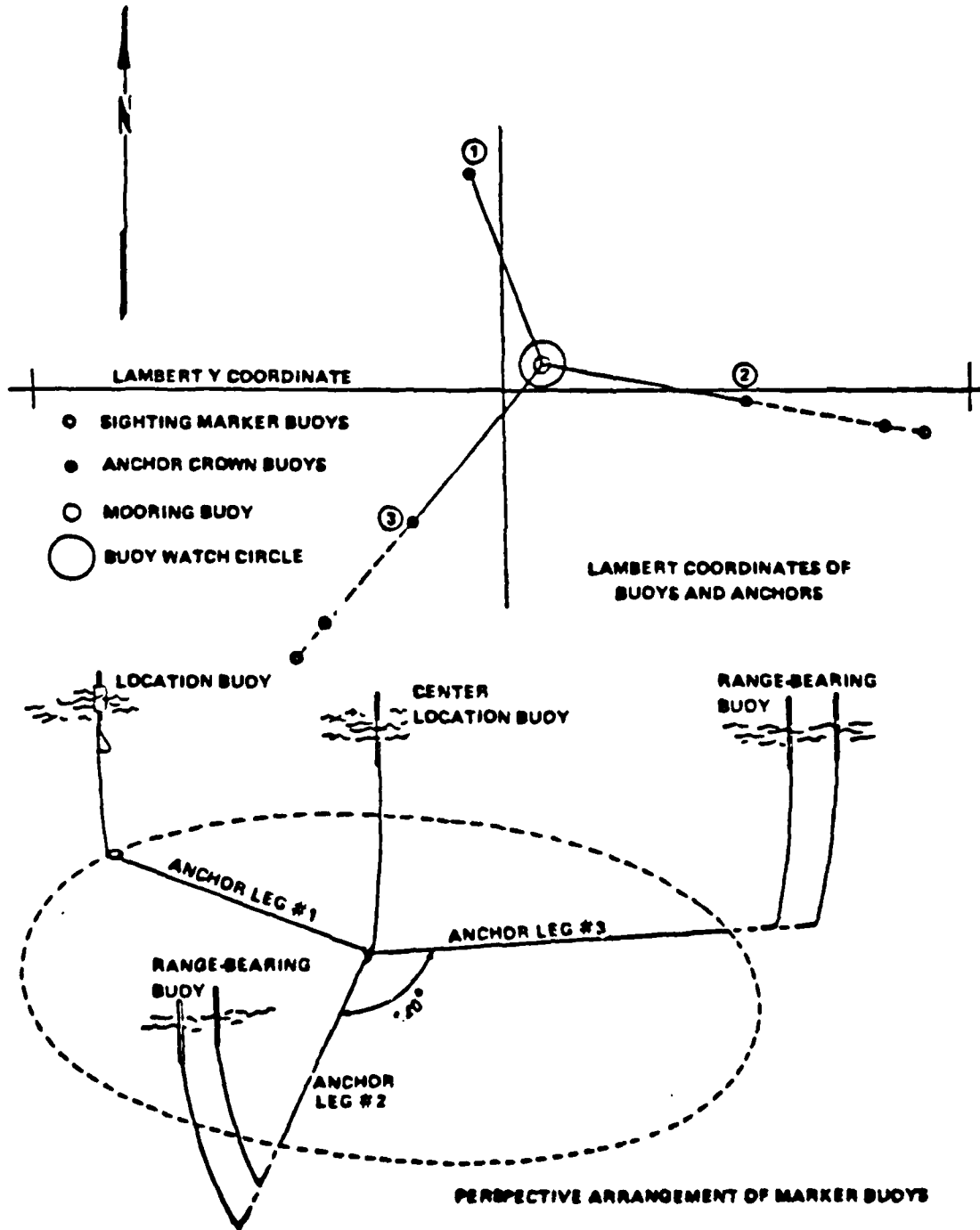

Figure 5-2

5.3 Install The Mooring

The complete installation will be executed in two stages. The first stage will consist of installing the mooring on location with the ground ring approximately 10 feet above the bottom. This is to keep most of the ground tackle on bottom and thus help maintain the mooring buoy on location during subsequent operations. The second stage will consist of lifting the mooring buoy and stoppering off the riser on deck. The riser will then be shortened to leave the ground ring at the design height (see appendices).

The installation will proceed as follows:

- o All components must be overboarded off the port side as the boom will not reach over the bow. All laying operations will be performed over the port bow.
- o The anchor for leg number 1 will be lowered and positioned on the bottom at the location buoy. Leg number 1 will then be layed as tug(s) maneuver the crane barge back to the center marker buoy.
- o Once at the center location buoy, the mooring buoy and two throw-off legs will be put in the water (see Figure 5-3).
- o The barge will return to the pier and on-load and lay out legs 2 and 3.
- o The barge will then be maneuvered for recovery of the pick-up line for throw-off leg number 2. The bitter end of leg number 2 will be stoppered-off on deck and the remainder of leg number 2 joined to it.
- o Laying of leg number 2 will proceed away from the center of the mooring using the range-bearing buoys for positioning. It is anticipated that a displacement of the mooring buoy will result from this operation (see Figure 5-4).
- o Position control for placing the anchor of leg number 2 will be by means of a plot board using the range information from the Mini-Ranger. Prior to reaching the desired anchor location, the anchor will be lowered to the bottom and then dragged onto location using the crown line.
- o Upon recovery and assembly of anchor leg number 3, the other mooring legs will be pulled taut. The barge will back down to the mooring buoy, then begin moving slowly forward while holding onto leg number 3. Once movement is started power will be stopped and the barge's inertia will pull the legs taut. Anchor number 3 will be layed similarly to anchor number 2 (see Figure 5-5).



OCEAN ENGINEERING AND CONSTRUCTION PROJECT OFFICE

INDIAN ISLAND MOORINGS

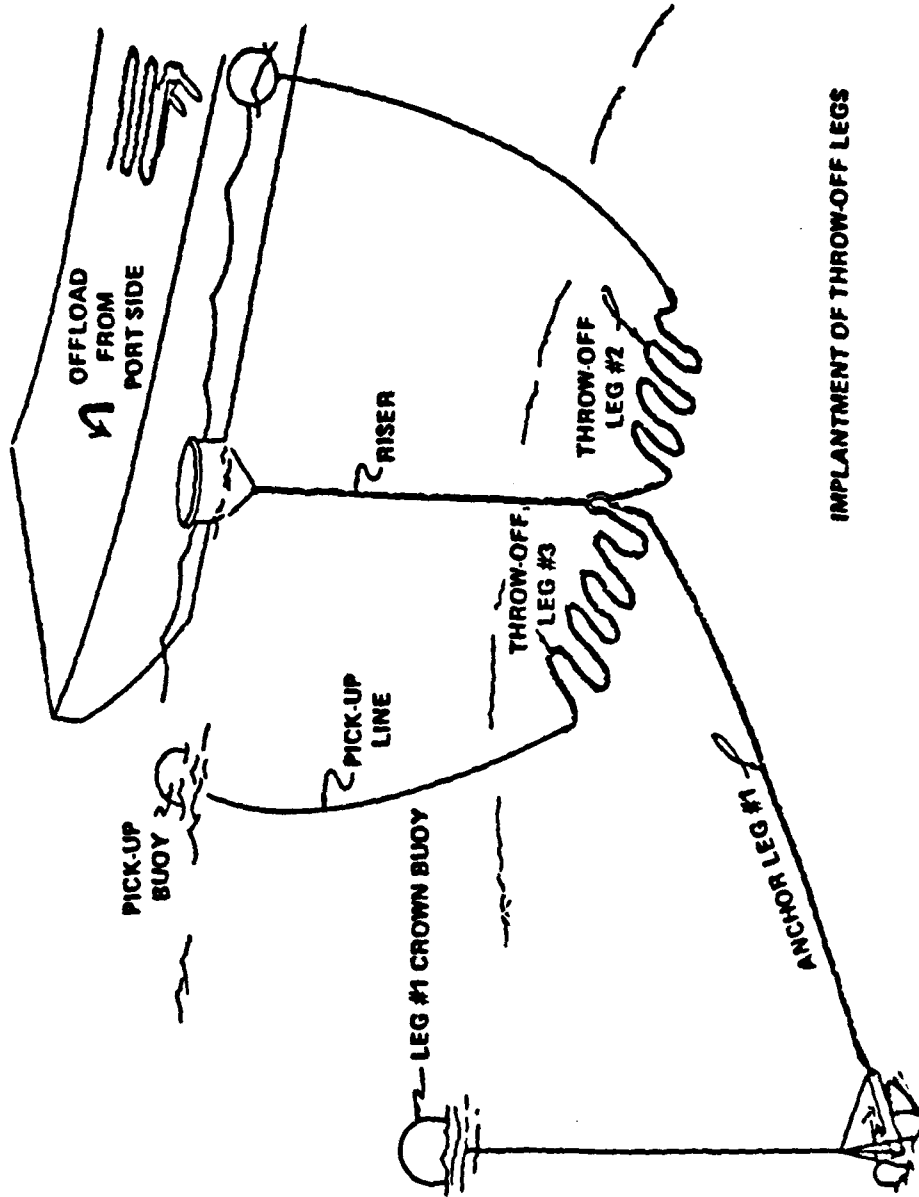

Figure 5-3



OCEAN ENGINEERING AND CONSTRUCTION PROJECT OFFICE

INDIAN ISLAND MOORINGS

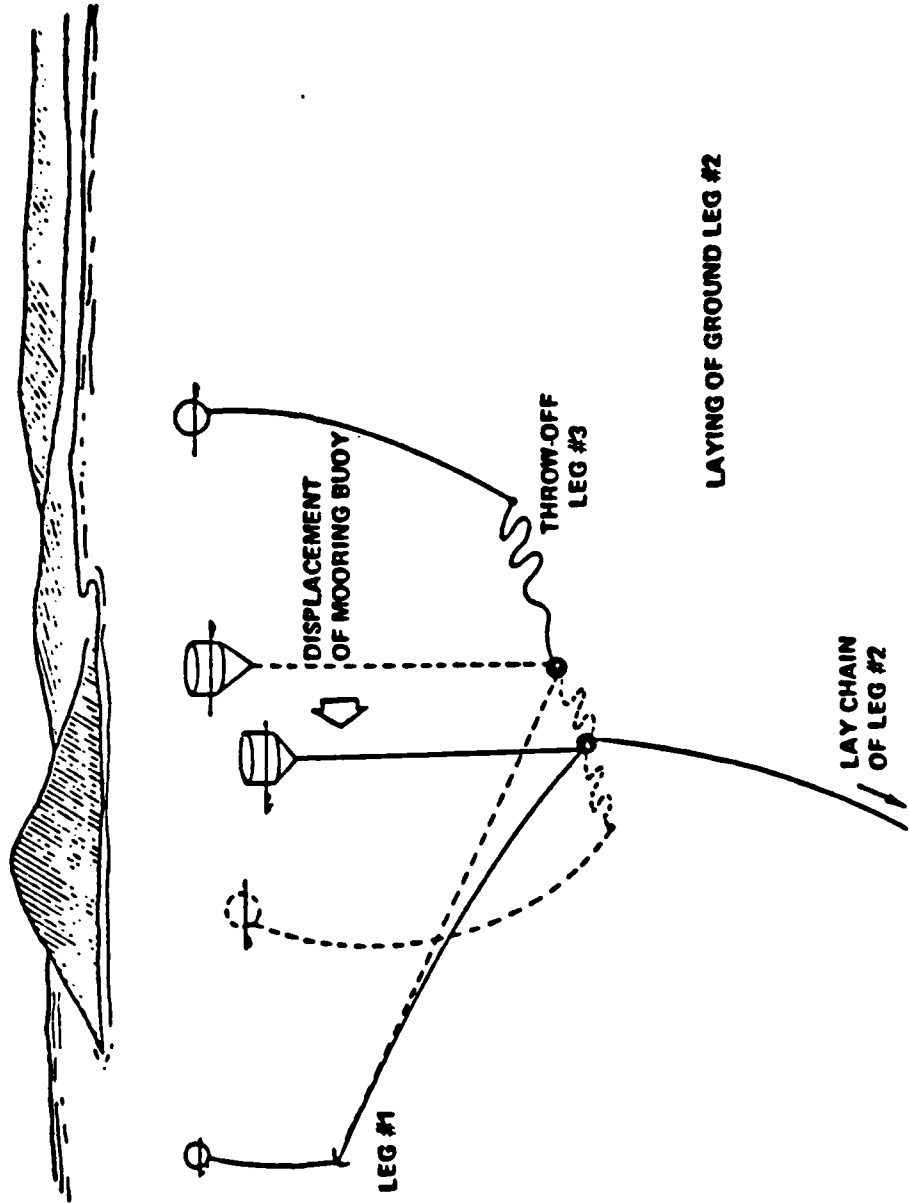
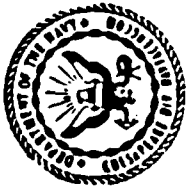

Figure 5-4



OCEAN ENGINEERING AND CONSTRUCTION PROJECT OFFICE

INDIAN ISLAND MOORINGS

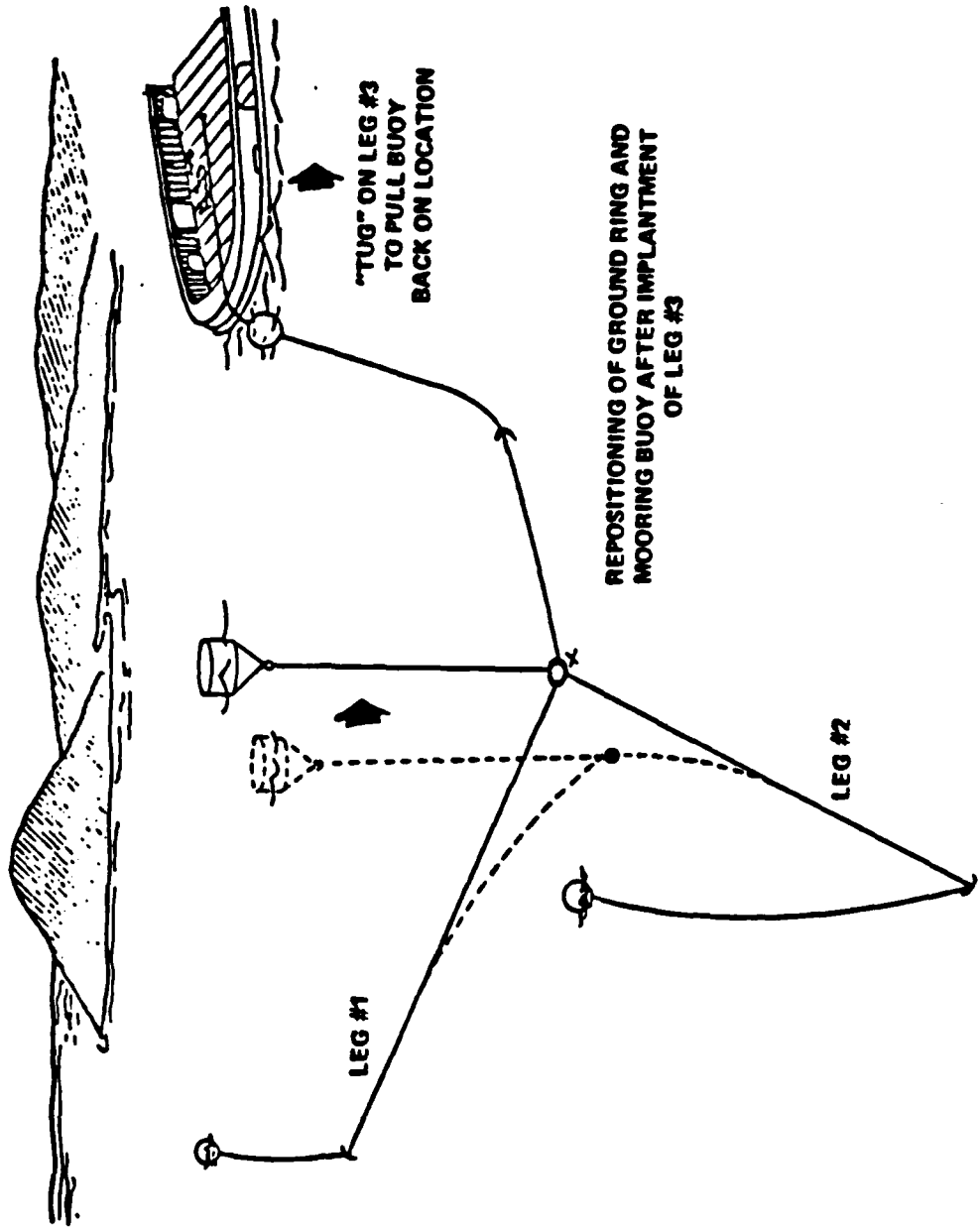

Figure 5-5

- o After completion of the first stage of installation, the final position of the mooring buoy will be adjusted, if necessary, to bring it on location at the center location buoy. This will be accomplished by picking up on the crown line and repositioning selected anchors.

5.4 Diver Inspection

Upon completion of the first stage of installation and adjustment of the mooring buoy position, divers will perform an underwater inspection of the mooring. See Facility Acceptance Test Section 6.0 for further discussion.

5.5 Second Stage of Installation

Upon satisfactory completion of the diver inspection, the mooring buoy will be lifted onto the deck of the crane barge and the riser stoppered-off. The riser will then be cut and shortened to provide the design height of the ground ring.

The purpose of this design is to create pretension in the anchor legs and thus reduce the watch circle of the mooring. To complete the initial lift of the mooring buoy, the anchors must be pulled in towards the center, for a proper distance.

Should one or more of the anchors fail to move the proper distance, a shift in the location of the mooring buoy will result. Depending on the magnitude of this relocation, selected anchors may be repositioned to bring the mooring buoy back on location. See Appendix B for drag distances.

6.0 FACILITY ACCEPTANCE TEST

The purpose of a Facility Acceptance Test is to demonstrate that the constructed facility will meet a defined set of performance criteria. For the Indian Island Moorings, the performance criteria is defined in terms of a maximum mooring watch circle that maintains the barge separations specified in Table B-1. The coordinates of each mooring were determined by assuming a mooring watch circle radius of 235 feet. This is based on a maximum buoy displacement of 50 feet under design load, a bridle length of 75 feet and a barge length of 110 feet. In addition, a circle of error for mooring location of ± 20 feet was provided.

For the three new moorings being installed, the facility "acceptance" criteria has been defined as a maximum mooring watch circle that lies within a 70-foot radius of the desired mooring coordinates. This is based on the 20-foot location tolerance and the 50-foot radius buoy watch circle under full load (12 kips). Thus the cumulative error in mooring location and measured buoy displacement under a 12 kip horizontal load should not be greater than 70 feet from the specified mooring coordinates.

Mooring number 1 is to be reinstalled with anchor stabilizers to increase its holding capacity. The mooring is still designed to meet the above watch circle restrictions when under a 12 kip load. However, in recognition of the reality that this mooring may experience greater loads, it is being positioned so that the watch circle resulting from a 25 kip load will not violate the minimum barge spacing.

A Facility Acceptance Test will be conducted for each mooring during its installation and will consist of four separate operations.

6.1 Diver Inspection

Immediately upon completion of the initial installation and prior to shortening the riser, a diver inspection will be performed. This will determine whether the anchors have been deployed with the flukes down, the anchor legs are layed out (no "balls" of chain) on the bottom and the anchor legs do not cross those of an adjacent mooring. In the event of an unacceptable condition, corrective action will be taken prior to proceeding with the installation.

6.2 Verification of Mooring Location

During the final stages of the installation a constant visual determination of the location of the mooring buoy relative to the center marker buoy will be conducted. The purpose of verifying the location of the mooring is to assure the center marker buoy has not been displaced during the installation. This may be accomplished by maneuvering the tug with the Mini-Ranger up to the mooring buoy and obtaining a "fix". In the event the location of the buoy is found to be further than 20 feet from the desired location, no action will be taken until completion of the Pull-Test and determination of the maximum mooring watch circle. Transits will be used as a back up or in lieu of this Mini-Ranger.

6.3 Pull-Test

The purpose of a Pull-Test is to determine the displacement of the mooring buoy under maximum design load. The test will consist of the tug pulling on the mooring buoy, (see Figure 6-1). A load cell will be used to measure the horizontal load generated. The test will proceed by slowly applying a horizontal load to the buoy until the design load (12 or 25 kips) is reached. For each mooring a minimum of six pulls will be made.

The position of the buoy before and after each load is applied will be obtained by transits at two locations on land. The transit operations will communicate with crane barge personnel by radio.



OCEAN ENGINEERING AND CONSTRUCTION PROJECT OFFICE

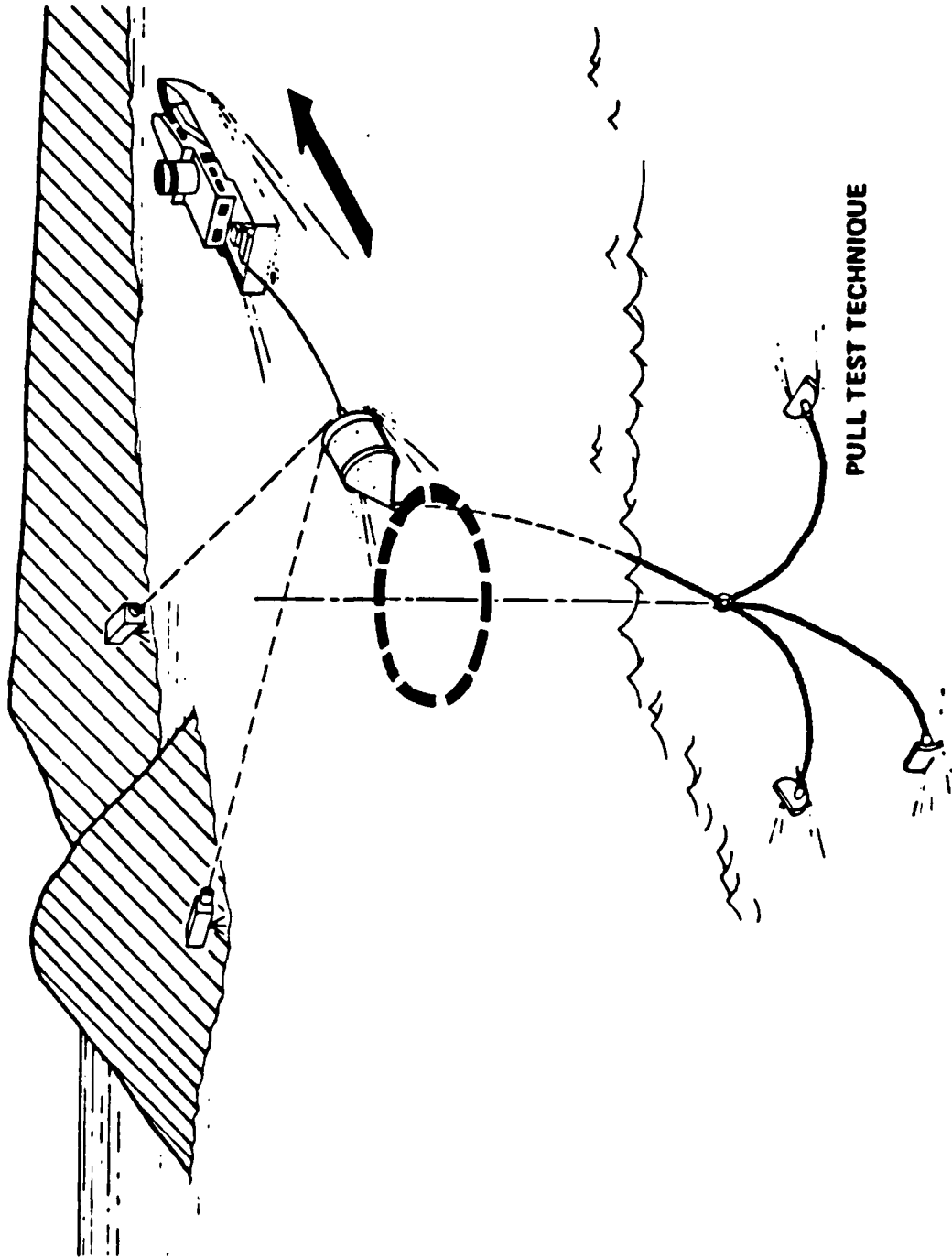

Figure 6-1

Successful completion of the Acceptance Test has been defined as a maximum mooring watch circle lying within a radius of 70 feet about the mooring coordinates. In the event the mooring watch circle is found to extend beyond the 70-foot radius, one or more anchors may be repositioned to either tighten up the buoy watch circle or reposition the buoy, or both.

In-the-field engineering design/judgment will be used to determine the appropriate course of action.

6.4 Recovery of Crown Lines

Upon successful completion of the Facility Acceptance Test, the crown lines will be recovered. Divers will descend on each line and disconnect the line, via a shackle, from the anchor. In the event the shackle is not accessible, due to anchor penetration into the bottom, the divers will be equipped with wire cutters to part the line at the mud line.

APPENDIX A

REFERENCES:

- a. CHESNAVFACENGCOM, Indian Island Moorings Project Completion Report, FPO-1-79(9), October 1979
- b. WESTNAVFACENGCOM letter 102.2, 28 April 1982
- c. Fonecon btwn J. Leimanis (COMNAVFACENGCOM) and T. Jones (CHESNAVFACENGCOM) of 22 April 1982
- d. CHESNAVFACENGCOM letter FPO-1FP2 of 3 June 1982
- e. CHESNAVFACENGCOM Washington DC 231406Z Dec 82
- f. NAVUSEAWARENGSTA Det Indian Island WA 071720 Jan 83
- g. CHESNAVFACENGCOM letter FPO-1C5 of 13 January 1983
- h. 144th Transportation Battalion, LT Mosebach letter to CHESNAVFACENGCOM, Lawrence Mendlow, of 22 May 1983
- i. UCT TWO 242131Z Jan 83
- j. CHESNAVFACENGCOM Washington DC 042030Z Feb 83
- k. CHESNAVFACENGCOM letter FPO-1C5 of 25 March 1983
- l. WESTNAVFACENGCOM, Work Request N62477-83-WR-00315

APPENDIX B - DESIGN DATA

Moored Crafts

YC and YFN

Environmental Criteria

Maximum Wind = 100 mph

Maximum Current = 2 knots

Factor for surge and swing per DM 26 = 1.33

Bathymetry

See Figure B-1

Explosive Quantity Safety Distances (ESQD)

See Figure 1-1 for minimum spacing of the moorings to points on land. Due to a navigational discrepancy during Phase I, the first three moorings were placed approximately 100 feet west of the planned locations shown. The locations of the Phase II moorings have been adjusted accordingly. Table B-1 shows the planned barge spacing and the required minimums.



OCEAN ENGINEERING AND CONSTRUCTION PROJECT OFFICE

INDIAN ISLAND BATHYMETRY (FEET)

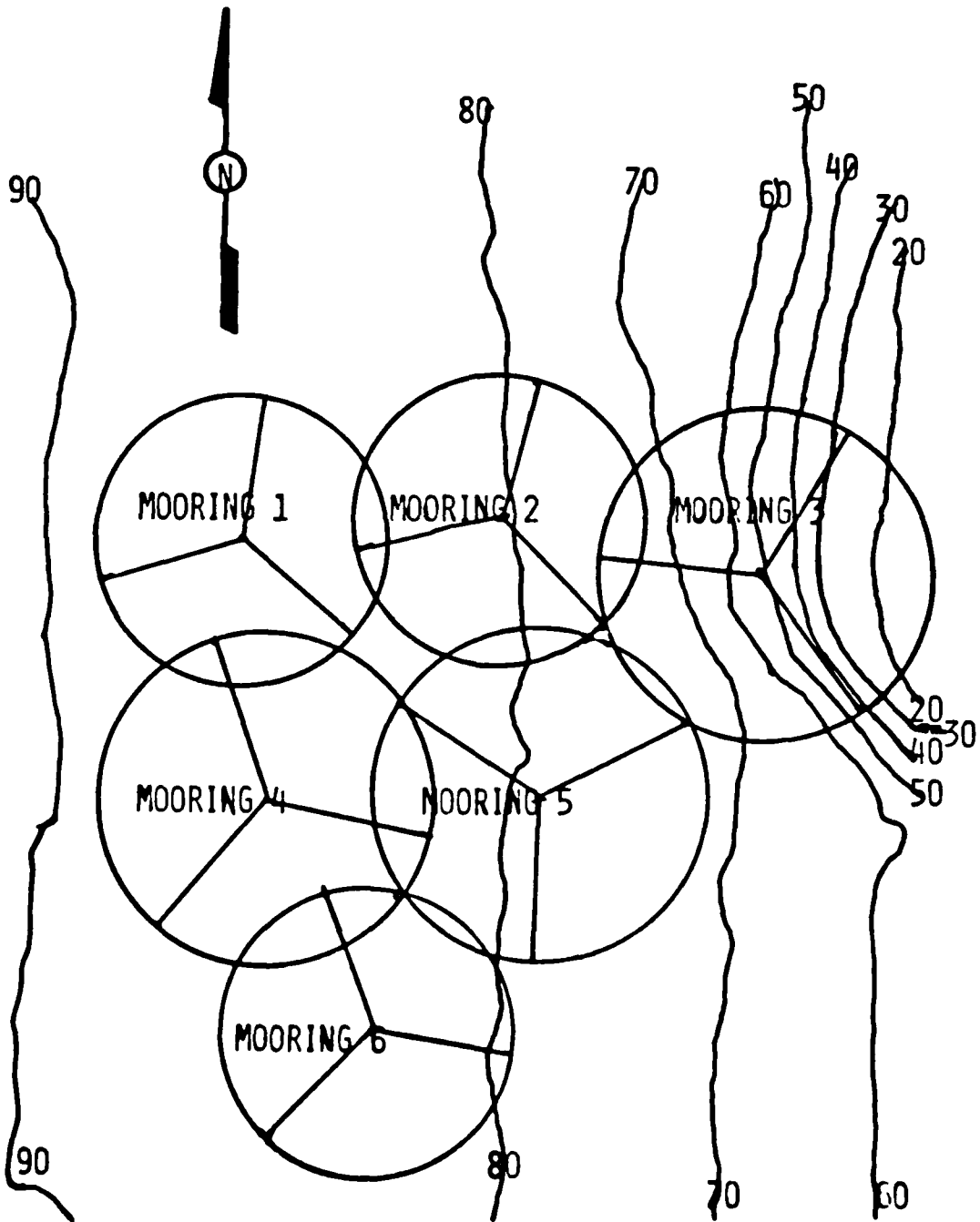

Figure B-1

PLANNED BUOY SPACING (FT.)

BUOY #	1	2	3	4	5	6
1		805	1592	828	1216	1575
2	795		795	1112	839	1594
3	---	795		1660	968	1829
4	795	---	---		823	770
5	---	795	---	765		868
6	---	---	---	765	735	

MINIMUM BUOY SPACING (FT.)

Table B-1

Planned Versus Minimum Mooring Spacing

Ground Ring Heights and Anchor Drag Distances

Table B-2 shows the planned ground ring heights and the acceptable range of anchor drag distances for each of the four moorings to be installed.

MOORING #	WATER DEPTH	GROUND RING HEIGHT	ANCHOR DRAG RANGE	
1	85	40	5-20	
3	A B C	24 61 77	30	10-20
4	85	40	10-27	
5	80	40	10-30	

- All distances in feet
- Ground Ring Height at MLLW

Table B-2

APPENDIC C

Table C-1 shows the marker buoy locations for the four moorings to be installed. The Range-Bearing buoys are paired. The inner marker buoy is 300 feet out from the anchor locations and the outer marker buoy is 400 feet out.

The buoy center locations are fixed but the location for the leg 1 marker will be adjusted once the true length of the legs are known in the field.

MOORING #	1		3		4		5	
	N	E	N	E	N	E	N	E
BUOY CENTER	394545	1531545	394432	1533133	393722	1531633	393740	1532456
LEG ONE	394278	1531864	394874	1533443	393628	1532165	394010	1532924
RANGE-BEARING LEG#2	395251	1531669	393671	1533488	393078	1531093	392900	1532456
RANGE-BEARING LEG#2	395349	1531686	393581	1533530	393001	1531079	392800	1532456
RANGE-BEARING LEG#3	394301	1530872	394505	1532296	394511	1531345	394160	1531728
RANGE-BEARING LEG#3	394266	1530778	394514	1532197	394605	1531311	394210	1531641

• All coordinates are in Washington State Lambert North Zone.

Table C-1
Marker Locations

END

FILMED

6-86

DITIC