

AD-A168 828

COMMAND AND CONTROL OF THE DIVISION REAR BATTLE(U) ARMY
COMMAND AND GENERAL STAFF COLL FORT LEAVENWORTH KS
SCHOOL OF ADVANCED MILITARY STUDIES G N ECKERT

1/1

UNCLASSIFIED

85 DEC 85

F/G 5/1

NL

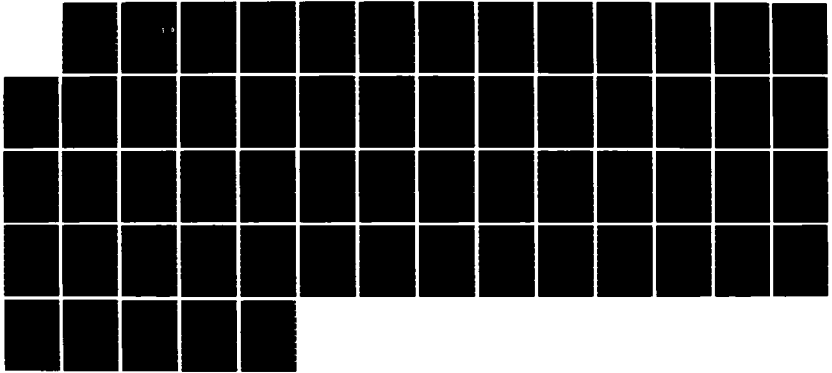

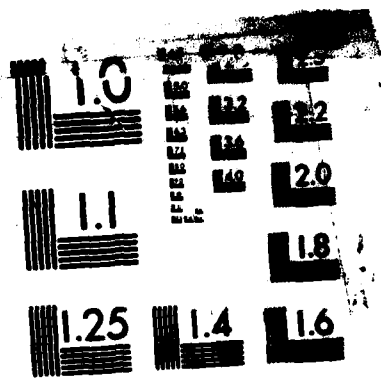

MICROCOPY RESOLUTION TEST CHART
NATIONAL BUREAU OF STANDARDS-1963-A

2

AD-A168 028

Command and Control of
the Division Rear Battle

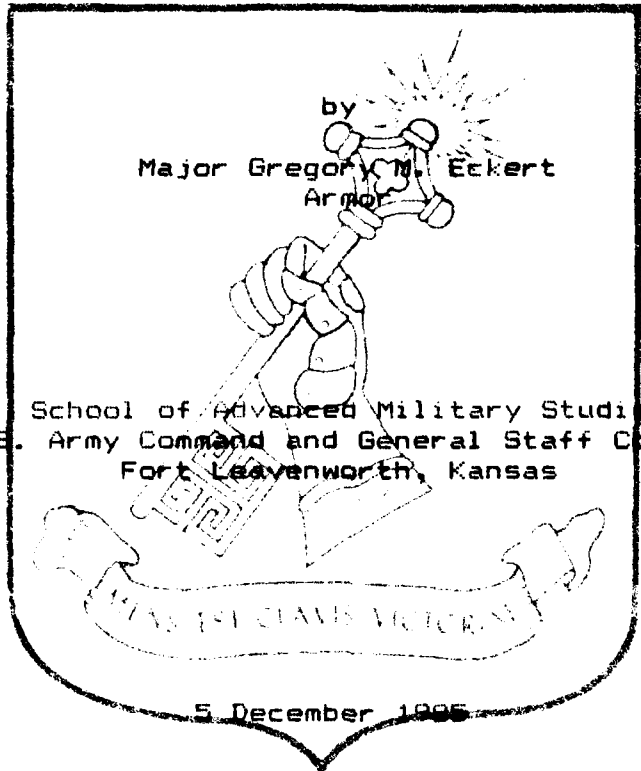

DTIC
ELECTE
MAY 22 1986
S **D**

DTIC FILE COPY

Approved for public release; distribution is unlimited

86 5 21 088

AD-A168028

REPORT DOCUMENTATION PAGE

1a. REPORT SECURITY CLASSIFICATION UNCLASSIFIED		1b. RESTRICTIVE MARKINGS	
2a. SECURITY CLASSIFICATION AUTHORITY		3. DISTRIBUTION/AVAILABILITY OF REPORT APPROVED FOR PUBLIC RELEASE: DISTRIBUTION IS UNLIMITED	
2b. DECLASSIFICATION/DOWNGRADING SCHEDULE		5. MONITORING ORGANIZATION REPORT NUMBER(S)	
4. PERFORMING ORGANIZATION REPORT NUMBER(S) School of Advanced Military Studies		7a. NAME OF MONITORING ORGANIZATION	
6a. NAME OF PERFORMING ORGANIZATION US ARMY COMMAND AND GENERAL STAFF COLLEGE		6b. OFFICE SYMBOL (If applicable) ATZL-SMB-GD SWV	
6c. ADDRESS (City, State, and ZIP Code) FORT LEAVENWORTH, KANSAS 66027		7b. ADDRESS (City, State, and ZIP Code)	
8a. NAME OF FUNDING/SPONSORING ORGANIZATION		8b. OFFICE SYMBOL (If applicable)	
8c. ADDRESS (City, State, and ZIP Code)		9. PROCUREMENT INSTRUMENT IDENTIFICATION NUMBER	
10. SOURCE OF FUNDING NUMBERS		11. TITLE (Include Security Classification)	
PROGRAM ELEMENT NO.	PROJECT NO.	TASK NO.	WORK UNIT ACCESSION NO.
12. PERSONAL AUTHOR(S) ECKERT, GREGORY M., MAJ, US ARMY		11. TITLE (Include Security Classification) COMMAND AND CONTROL OF THE DIVISION REAR BATTLE	
13a. TYPE OF REPORT MONOGRAPH	13b. TIME COVERED FROM TO	14. DATE OF REPORT (Year, Month, Day) 1985, DECEMBER, 05	15. PAGE COUNT 51
16. SUPPLEMENTARY NOTATION			
17. COSATI CODES		18. SUBJECT TERMS (Continue on reverse if necessary and identify by block number)	
FIELD	GROUP	COMMAND AND CONTROL REAR BATTLE DIVISION	
		DIVISION TRAINS COMMANDER RAO	
19. ABSTRACT (Continue on reverse if necessary and identify by block number) This study examines current US command and control doctrine for the division rear battle as presented in FM 90-14 <u>Rear Battle</u> . The adequacy of current division rear battle command and control doctrine is analyzed within the context of the AirLand Battlefield in light of the historical experiences of US armored divisions in World War II. The primary conclusion is that the principle of unity of effort, which FM 90-14 suggests is necessary in conducting the rear battle, and which was a critical factor in the successful conduct of the rear battle by US armored divisions in World War II, is missing in our current doctrine. The attempt by our current doctrine to integrate the division's rear security effort across organizational and functional boundaries is unrealistic. This has resulted in the establishment of confusing and redundant command and staff relationships involving, among others, the RAO, G3, and rear battle officer. (continued on back)			
20. DISTRIBUTION/AVAILABILITY OF ABSTRACT <input checked="" type="checkbox"/> UNCLASSIFIED/UNLIMITED <input type="checkbox"/> SAME AS RPT. <input type="checkbox"/> DTIC USERS		21. ABSTRACT SECURITY CLASSIFICATION UNCLASSIFIED	
22a. NAME OF RESPONSIBLE INDIVIDUAL MAJ GREGORY M. ECKERT		22b. TELEPHONE (Include Area Code) 913-684-3345	22c. OFFICE SYMBOL ATZL-SMB-SWV

UNCLASSIFIED

SECURITY CLASSIFICATION OF THIS PAGE

The primacy of command rather than control must be restored in our rear battle doctrine. In this regard, what is needed is a rear brigade equivalent commander along with his own headquarters and staff, analogous to the armored division trains commander of World War II.

UNCLASSIFIED

SECURITY CLASSIFICATION OF THIS PAGE

Command and Control of
the Division Rear Battle

by

Major Gregory M. Eckert
Armor

School of Advanced Military Studies
U.S. Army Command and General Staff College
Fort Leavenworth, Kansas

5 December 1985

Approved for public release; distribution is unlimited

Accession For	
NTIS CRA&I	<input checked="" type="checkbox"/>
DTIC TAB	<input type="checkbox"/>
Unannounced	<input type="checkbox"/>
Justification	
By	
Distribution /	
Availability Codes	
Dist	Avail and/or Special
A-1	



86-2187

School of Advanced Military Studies

Monograph Approval

Name of Student: Major Gregory M. Eckert

Title of Monograph: Command and Control of the Division
Rear Battle

Approved by:

John S. Fulton Seminar Leader
Lieutenant Colonel John S. Fulton, M.A.

Richard H. Sinnreich Director, School of
Colonel Richard H. Sinnreich, M.A. Advanced Military
Studies

Philip J. Brookes Director, Graduate
Philip J. Brookes, Ph.D. Degree Programs

Accepted this 31st day of December 1985.

ABSTRACT

COMMAND AND CONTROL OF THE DIVISION REAR BATTLE by Major Gregory M. Eckert, USA, 51 pages.

This study examines current US command and control doctrine for the division rear battle as presented in FM 90-14, Rear Battle. The adequacy of current division rear battle command and control doctrine is analyzed within the context of the AirLand Battlefield in light of the historical experiences of US armored divisions in World War II.

The primary conclusion is that the principle of unity of effort, which FM 90-14 suggests is necessary in conducting the rear battle, and which was a critical factor in the successful conduct of the rear battle by US armored divisions in World War II, is missing in our current doctrine.

The attempt by our current doctrine to integrate the division's rear security effort across organizational and functional boundaries is unrealistic. This has resulted in the establishment of confusing and redundant command and staff relationships involving, among others, the RAOC, G3, and rear battle officer. The primacy of command rather than control must be restored in our rear battle doctrine. In this regard, what is needed is a rear brigade equivalent commander along with his own headquarters and staff, analogous to the armored division trains commander of World War II.

TABLE OF CONTENTS

	page
Section I. Introduction	1
II. Background	4
III. Historical Overview	8
IV. Current U.S. Doctrine	20
V. Analysis	28
VI. Conclusions	36
Appendix A. The 6th Armored Division in the Exploitation	40
B. The 7th Armored Division in the Defense of ST Vith	41
C. Division Rear Area Tactical and Technical Chains of Command	42
D. Combined Tactical and Technical Division Rear Chain of Command	43
Endnotes	44
Bibliography	48

I. Introduction

Rear area operations have always played a critical role on the battlefield. However, it is only recently with the publishing of the Army's AirLand Battle doctrine that rear operations in general and their relationship to close and deep operations in particular have received the kind of attention warranted. FM 100-5 (Draft) notes that "Operations in the rear area contribute to the unified plan by preserving the commander's freedom of action and assuring uninterrupted support of the battle."¹

FM 100-5 (Draft) views rear operations as all:

combat, combat support, and combat service support operations conducted in the rear area of an echelon of command for the purpose of sustaining combat in forward areas and maintaining the freedom of action of the command."²

One reason for the increased attention rear operations are receiving is the Soviet rear area threat. Not only do the Soviets possess extensive conventional and unconventional forces capable of disrupting rear operations; but their doctrine emphasizes the use of these forces in both the offense and defense as a means of unhinging the enemy's operational plan.

The threat, along with the rapid and fluid nature of modern warfare, will cause operations to assume a distinctly nonlinear character and will "blur the distinction between front and rear and will impose a requirement for all around defense and self-sufficiency on all units."³ This clearly suggests that our Army must develop both the appropriate

security measures and the necessary command and control system to ensure not only the continued support of close and deep operations, but also to provide the capability to integrate rear operations into the commander's overall tactical scheme.

FM 100-5 (Draft) categorizes rear operations into the four activities of command and control, reserves, long-range fires, and combat service support. However, the security of these activities, the protection of key facilities and key locations such as bridges, dams, and traffic choke points, and the associated detection systems needed to monitor the situation in the rear area encompass the doctrinal concept of the rear battle which FM 90-14 defines as:

...those actions, including area damage control, taken by all units (combat, combat support, combat service support, and host nation) singly or in a combined effort, to secure the force, neutralize or defeat enemy operations in the rear area, and ensure freedom of action in the deep and close-in battles. 4

This paper's focus is on the rear battle as defined in FM 90-14 and not on rear operations in general as discussed in the recent draft edition of FM 100-5. Hence, the term rear battle as used in this paper corresponds to the definition used in FM 90-14.

FM 90-14 lists unity of effort as one of three principles essential in conducting the rear battle. This principle is also one of the AirLand Battle imperatives and is based on three principles of war, the objective, unity of command, and simplicity.⁵ It is this paper's hypothesis, however, that while our Army's recently published doctrine regarding the conduct of the rear battle claims to incorporate unity of

effort as one of its basic principles; the rear battle command and control doctrine presented in FM 90-14 violates this very principle.

This paper will only examine command and control of the rear battle at the division level. Its scope is further limited to an examination of rear battle command and control in a US heavy division. The combat environment assumed is a mid to high intensity non-nuclear war in Western Europe against the Soviets and their Warsaw Pact surrogates. Finally, while rear battle doctrine also encompasses area damage control (ADC), this aspect of the rear battle is not addressed in this paper.

The paper is organized in six sections. The first section is the introduction. The second section establishes the background of the problem. This includes an examination of the AirLand Battle in Europe and an identification of the current Soviet rear area threat. The third section is a historical overview of the command and control of rear area security in US armored divisions during World War II. The fourth section is a review of the recently published doctrine in FM 90-14 regarding the command and control of the division's rear battle. The fifth section analyzes the adequacy of our rear battle command and control doctrine in light of the historical experiences of US armored divisions in World War II, the Soviet threat, and the AirLand Battlefield. The sixth section contains conclusions.

While this paper arguably may contain many implicit

assumptions, there is one significantly explicit assumption. Namely, though the technical aspects of rear area operations have increased significantly in complexity, there are certain basic precepts regarding the integration of rear operations into the overall battle in general and the command and control of security operations in the rear area in particular which hold as true in today's heavy division as they did for a US armored division during World War II.

II. The Background

The future division battlefield in Central Europe will be characterized by highly intense and fluid operations extending over broad areas of territory both laterally and in depth. This rapid movement, made possible through the use of highly lethal mechanized ground forces and air forces, will result in the intermingling of opposing forces to such a degree that the classic distinction between the main battle area and the rear area will be confused at best and arguably lost altogether, particularly at division level and below. Considering that the division rear contains the majority of the division's combat support and combat service support and noting that this same area contains few combat troops, the Soviet rear area threat assumes even greater significance.

The Soviets believe that any war fought in Europe must be brought to a rapid conclusion before either substantial US reinforcements arrive or the war escalates to a nuclear confrontation. As a result, the Soviets have continually advocated that operations must develop and maintain a rapid

tempo. An effective way of ensuring that operations maintain this rapid tempo is by attacking the enemy throughout his tactical and operational depths to disrupt his forward support and his defenses. Not only have the Soviets created a force structure with significant capabilities to conduct operations against the enemy's rear, but they have also developed an effective doctrine for its integration into their overall tactical and operational scheme.

Some of the most likely targets the Soviets might attack in the division rear include nuclear and chemical delivery means, command and control systems, logistics facilities, transportation networks, and critical terrain in the rear area such as river crossing sites or defiles. In addition to the significant amount of air, artillery, and EW assets which can be employed against these targets, the Soviets have a large conventional ground force capability which can be used in the enemy's rear.

This capability begins at the regimental level and extends all the way to army and front. The most basic ground forces the Soviets could employ in our rear are their organic reconnaissance units. These include the reconnaissance company at regimental level and the reconnaissance battalion in each motorized and tank division. These would be employed in our divisional rear area primarily in a reconnaissance role, but could conduct combat operations against targets whose destruction the Soviets believed was critical to the success of their operations.

The Soviets also possess and plan to use various heliborne forces in the enemy's rear in conjunction with normal operations. Each Soviet tank and combined arms army has an organic air assault battalion; and each front has an air assault brigade. Motorized rifle battalions from the division, when provided with additional lift assets from higher headquarters, can also perform air assault operations in the enemy's rear area.

The Soviets also maintain large, well trained airborne forces which could be employed at the front or TVD level. Although these forces would normally be used to seize deep operational level objectives, battalion or regimental size operations could be conducted in a division's rear as well.

In addition to the forces discussed above, we can expect the Soviets to employ sizeable ground maneuver forces in our rear in support of their main effort. One of these is the forward detachment. This unit is normally formed around a battalion or regiment and is given the mission of quickly penetrating into the depths of the enemy's defenses to disrupt his defensive structure, open avenues of approach for the main attack, or link up with other units inserted earlier such as heliborne forces. Another ground force threat to the divisional rear area is the operational maneuver group (OMG). This is a semi-independent force designed to conduct operations deep in the enemy's rear to seize operational level objectives. This force is normally formed around a reinforced tank division at army level and a multi-division corps or army at front level. Again, while an OMG's ultimate objective

would probably lie well to the rear of a division's rear boundary, Soviet doctrine states that this force may also be used to disrupt enemy rear operations enroute to its final objective.

The Soviets have available and plan to employ large numbers of unconventional warfare forces as well. These range from agents who have been in place for years, to specially trained units (Spetsnaz) who are inserted into the rear shortly before or after hostilities begin. These units are specially trained in sabotage and reconnaissance. It is expected that a combined arms or tank army would have a Spetsnaz company attached to it and a front would have an independent Spetsnaz brigade. Although these forces would typically be assigned operational level objectives, some of them could also be assigned certain key objectives in a division's rear area.

While the emphasis up to this point has been on Soviet operations in the division rear in the offense, it can be expected that the Soviets will attempt to conduct operations against key targets in the enemy's rear while on the defense as well. In World War II, there were recorded instances of regimental and divisional sized elements continuing to disrupt German rear area operations for weeks on end. Frequently, their elimination required the commitment of significant front line combat units.

This same philosophy continues today with current Soviet doctrine. As an example, Novikov describes some of the targets

and objectives of bypassed units below:

Bypassed units may therefore be given other missions, such as reconnaissance and sabotage, including surprise attacks on individual enemy columns, launching sites and firing positions, and may inflict heavy losses by harassing enemy open flanks and dislocate the enemy's control system by raiding his command posts. 8

It is within the environment described above that the division rear battle will be conducted. However, prior to discussing our current rear battle doctrine, a brief examination of security in the division rear area during World War II will be presented as a means of establishing a historical frame of reference.

III. Historical Overview

This section of the paper is intended to provide insights regarding the adequacy of current rear battle command and control doctrine in light of the experiences of the US armored division during World War II. The 6th Armored Division in the exploitation and the 7th Armored Division in the defense in World War II were chosen for several reasons. First, the US armored division in World War II is comparable to today's heavy division in organization and missions. Second, an examination of the 6th and 7th Armored Divisions also provides a means of investigating the successful conduct of the rear battle in both the offense and the defense. Third, the fluid and nonlinear nature of the battlefield upon which these two units fought compares favorably in both scope and complexity to the type of warfare US mechanized and armor divisions are expected to encounter in a future European war.

The 6th and 7th Armored Divisions were organized around a division headquarters, two combat command headquarters, a reserve command headquarters, a division artillery headquarters, and a division trains headquarters. Major combat elements in the division were three tank battalions, three armored infantry battalions, three field artillery battalions, a reconnaissance squadron, an engineer battalion, a signal company, and an MP platoon. The division was normally reinforced with additional artillery battalions, an anti-aircraft battalion, and a tank destroyer battalion. These elements were task organized around the headquarters listed above. The division typically fought with the two combat commands acting as brigade size task forces. The reserve command was used either as a headquarters for rotating units into and out of the combat commands or as a third task force control headquarters.

The division combat service support elements consisted of a maintenance battalion, a medical battalion, and the division band. Two quartermaster truck companies and a quartermaster gas company were normally attached to the division as well. These units, along with the other logistical elements in the division, were organized into flexible groupings which corresponded to the main echelons of command. These groupings were the combat, field, and division trains and were very similar to today's present trains structure. The division trains, under the command and control of the division trains commander, consisted of the remaining supply, evacuation,

transportation, service, and administrative elements of the division not assigned or attached to the combat or reserve commands and not retained under direct control of the division commander. These normally included the division headquarters rear echelon, the MP platoon, air defense units, and occasionally, some combat and combat support units. ¹⁰

The 1951 edition of FM 17-50 described the division trains commander as follows:

The division trains commander is a tactical commander. He commands all assigned and attached units of division trains and is directly responsible to the division commander for all activities taking place within the division trains, except for those operations which are staff responsibilities of the division general and special staff officers. ¹¹

His duties included the following:

- a. Tactical command and control of organic and attached division trains units.
- b. Organization of division trains for movement in bivouac areas.
- c. Movement of the trains, consistent with the division tactical plan, to include route and bivouac selection and reconnaissance (in coordination with the G3 and G4).
- d. Protection and security of the division trains.
- e. Preparation of tactical plans for the movement, control, and protection of the division trains. ¹²

The trains commander was also provided with his own organic headquarters and headquarters company whose mission was

...to provide the tactical control of the division trains, attached units, and such unit

trains as may be under division control, and to provide administrative, mess, and service support for the rear echelon of division headquarters and the division band. 13

The division trains commander worked closely with the division's primary logistics operator, the G4, who was responsible for planning, supervising and coordinating the division's logistical operations. The G4's duties were primarily in the areas of supply, evacuation and hospitalization, transportation, service, and logistics administration. In addition, he also recommended the locations of the division rear boundary, the rear echelon headquarters, and the service areas. 14

While it may appear that there was a large potential for conflict between the trains commander and the G4, as then LTC Creighton Abrams noted:

The functions and responsibilities of the division trains commander in no way restrict the normal staff relationship between G-4 and the technical staff, some of whom are also commanders of technical service units. 15

Regarding movement control, the G4 normally gave the movement orders for the division trains including when, where, and type (infiltration or normal column) through the trains liaison officer in the forward echelon to the division trains commander. The trains commander exercised movement control through the commanders of organic and attached units and liaison officers using oral or fragmentary movement orders which included route(s), order of march, method of control, and security elements. The division trains command radio net was used to control the movement which was made, consistent

with security requirements, by echelons or bounds. The division trains reconnaissance element augmented the advance parties for route and bivouac reconnaissance. ¹⁶

The security measures adopted in the armored division were consistent with the general principles set forth in the 1944 version of FM 100-5:

Each commander is responsible for the security of his command. This includes the protection of his lines of communication unless such protection is furnished by the higher commander. The superior commander prescribes security measures for the protection of the command as a whole or coordinates those adopted by subordinate commanders. He insures that measures adopted are appropriate to the hostile threat. Subordinate commanders provide additional security required for their own local protection. When contact is imminent, security measures are increased. ¹⁷

Security procedures adopted in the division rear area in general and the trains in particular were consistent with this concept. While the trains commander was responsible for overall security on the march and in bivouac, subordinate elements were responsible for local security using organic individual arms, machine guns, and anti-tank rocket launchers against isolated enemy groups or patrols. When a stronger enemy was encountered, attached combat troops were used or additional help was requested from the division.

One final aspect of World War II armored division rear operations needs to be discussed, the division supply control point (DSCP). FM 17-50 described the DSCP as:

...a control activity and installation, located on the division main supply road in the vicinity of the division mobile supply points. Its mission is to regulate and expedite logistical support of the combat elements, particularly

resupply during combat.

The DSCP was normally located 5-10 miles behind the forward combat elements, but forward of the division trains. It was operated by an officer designated by the G4 and was positioned close to the class I, III, and V supply points, normally along the MSR. Convoys returning from the division's front would report back to the DSCP for directions to the appropriate logistics installation. In certain situations, security considerations dictated that it and the division supply points co-locate with the division trains. Since the light armored division TO&E did not provide for this organization, the DSCP was normally supplemented (particularly for security) with personnel from the division band, ammo control section, and division trains headquarters.

Having established a doctrinal basis for armored division rear operations in general and rear area security in particular, attention will now turn to how command and control of the rear battle occurred in practice in the 6th and 7th Armored Divisions.

In late July 1944, Operation Cobra had succeeded in penetrating the German lines in the vicinity of ST. Lo, France. When it was discovered that the enemy was rapidly withdrawing, the 3d Army (which had just been activated on 31 July) issued orders for the VIII Corps to exploit with the 4th Armored Division driving south to Lorient to seal off the Brittany Peninsula and the 6th Armored Division driving west across the peninsula to seize the key port facilities at Brest (see Appendix A).

The 6th Armored Division raced across the Brittany Peninsula in a little more than a week with Combat Command B in the north and Combat Command A in the south along parallel routes while the reserve combat command followed the combat command making the best progress. As the division continued its exploitation to the west, numerous enemy forces from 500 to 4000 strong were bypassed. Additionally, the division trains found themselves increasingly isolated from the division's combat units 70 miles to the front and its parent army's supply points 200 miles to the rear.

In addition to the normal trains elements, two quartermaster truck companies, a quartermaster gas company, elements of a bridge company, two AAA batteries, the divisional MP platoon, the rear echelon CP, and the division band had initially been attached to the division trains. However, the increasing threat to the division's rear resulted in the further attachment of a tank company, an armored infantry company, and a tank destroyer platoon to the trains.

Trains elements were subjected to harassing attacks which increased in intensity and severity from both the air and from bypassed enemy ground units. In one particular instance, the division's forward gas supply point was attacked by 150 German paratroopers. The supply point, which was guarded by the division band and a section of light tanks, drove off the enemy with moderate casualties and a loss of 5000 gallons of fuel. As another indication of the amount of enemy activity

in the division's rear, the trains alone captured over 1000
21
POWs during this period.

Movement control and security operations for the approximately 700 vehicles in the division trains were generally accomplished along the doctrinal lines described earlier in this section. General movement times and locations for the trains were recommended by the G4 while the overall command and control of all the trains elements was accomplished by the division trains commander. The MP platoon was severely taxed to provide traffic control given the large number of POWs. As a result, it was frequently augmented with various personnel from the trains who assisted in traffic control and also conducted route and bivouac reconnaissance. 22

The DSCP was used extensively. The division trains headquarters and headquarters company commander exercised overall command of the DSCP. Security was generally provided by trains personnel supplemented by some of the attached combat elements. Technical support was provided by the division's quartermaster section, the division ammo officer, and elements of the attached quartermaster truck company. The DSCP performed several critical functions. First, it provided a means of traffic control and regulation in the division rear area. Second, it served as a focal point for organizing convoys (to include security provisions) going forward and to the rear. Third, it was a key center for gathering and disseminating intelligence regarding enemy activity in the rear area. 23

A fitting testimony to the effectiveness of the division

trains operations was given by the commander of one of the German divisions opposing the 6th Armored Division.

I cannot understand these Americans. Each night we know that we have cut them to pieces, inflicted heavy casualties, and mowed down their transport. We know in some cases we have almost decimated entire transport columns. But in the morning we are faced with troops well supplied with transport, food, tools, and weapons... LTC Elmer H. Droste, moving the trains forward day and night, under conditions that presented untold difficulties, accomplished the mission of the division trains in an outstanding manner. 24

In contrast to the 6th Armored Division, the 7th Armored Division found itself in a very different set of circumstances in mid December 1944. The 7th Armored Division, as part of the 1st Army, played a key role in the defense of the Ardennes, better known as the Battle of the Bulge. For a six day period, against superior enemy forces, the 7th Armored Division checked and held the center of the German counteroffensive by denying the Germans the critical communications network of ST. Vith.

During the period of 17 and 18 December, the 7th Armored Division along with the 112th Regimental Combat Team (28th ID), Combat Command B of the 9th Armored Division, various remnants from the 106th Infantry Division, and other combat units were able to establish a horseshoe defense centered around the key road network center at ST. Vith. The division trains occupied an area in the vicinity of La Roche and established a forward supply point in the vicinity of Samree. This supply point was approximately 3 miles east of La Roche and 10 miles southwest of Vielsalm (see Appendix B).
25

While the forward combat units were able to establish a somewhat coherent defense, the same was not true in the division's rear area. As LTC Erlenbusch noted:

As a result of these (enemy) forces 'slipping by' on the flanks, our division rear area was a mixture of friendly and enemy troops. Some Corps and Army ASPs were in our hands; some were in the hands of the enemy; some changed hands frequently; while other supply points were destroyed or evacuated by retiring friendly troops. 26

The confusing situation in the division's rear compounded the division trains commander's problems since he had to execute several missions.

Col Adams (the trains commander) knew the positions of the forward elements and well understood that he would not only have to move supplies, but would have to defend himself and protect the Division rear as well. 27

To further complicate matters, the division trains commander was given no additional combat troops. In order to accomplish his mission, the trains commander established twelve roadblocks in and around the La Roche/Samree area. Manning these roadblocks were trains personnel, personnel from the 440th AAA Service Battery, D Battery of the 203d AAA, and miscellaneous corps troops (including corps engineers operating a saw mill in the area). Tanks and other combat vehicles coming out of maintenance supplemented these units and provided limited convoy security. 28

The division rear area was subjected to constant harassing attacks culminating on 20 December when a German infantry battalion supported with artillery attacked the forward supply point at Samree. Approximately 50 service personnel

successfully defended the supply point during the morning. However, even though help arrived later in the day in the form of a task force from the 3d Armored Division, the Germans eventually forced the trains personnel to evacuate the town.

As noted in an account of this action:

Throughout the attack on the division supply points...supplies of rations and gasoline were issued to the unit trains of various battalions of the 7th Armored Division as well as to the 112th Infantry RCT(28th Div)and elements of the 106th Division. While one end of the dump was on fire and under attack, issues took place from the other end...Known casualties to service personnel during the attack were 17 killed, 12 wounded and 4 captured. 29

Although the Germans did capture a sizeable amount of fuel and rations, the actions of Col Adam's divisions trains prevented the Germans from quickly exploiting the situation. This allowed the recently arrived 84th Infantry Division and the 3d Armored Division to establish a shoulder against further penetration.

Due to increased enemy pressure, the trains were forced to move 12 miles farther to the west behind the 84th Infantry Division. However, the trains continued to support the forward units in a timely and effective manner. In particular, on the 22d of December, a 90 vehicle convoy, protected only by combat vehicles returning to their parent units, carried desperately needed rations, fuel, and ammunition through a very narrow corridor to the almost encircled forward elements. This was significant in enabling these elements to execute a largely successful withdrawal out
30
of the ST. Vith area on the 23d of December.

The 6th and 7th Armored Divisions were confronted with the formidable task of conducting sizeable rear area operations (albeit perhaps not as sophisticated as they are today) while faced with a significant rear area threat. Their success in performing this task can, in large part, be attributed to a simple but effective rear area security command and control system based around the trains commander and his headquarters. Both the role of the trains commander and the concept of security in the division rear area have evolved considerably since then.

During the 1950s, the role of the trains commander changed as the need for a centralized division logistics command (a forerunner of today's DISCOM) was identified. Yet, even into the late 1950s, the division logistics commander (who replaced the trains commander) was still used as both the division's rear area tactical commander and its administrative and logistics commander. The role of the division logistics commander continued to evolve during the 1960s. Based on the increase in both the scope and complexity of division logistics operations, the division support commander (replacing the title of division logistics commander) lost his tactical role and became exclusively, the division's primary logistics operator. While he was still held responsible for the security of the division support command and its associated support area, he was no longer held responsible for the security of other units located in the division rear. ³¹

Doctrine regarding division rear area security also evolved during this period. The G3 was given overall staff

responsibility for the division's rear area security operations and was responsible for coordinating areas of responsibility with the major subordinate commands located in the rear. Each commander continued to be held responsible for his own unit's security. There was no attempt to formally integrate the entire division's rear area security through the introduction of an additional rear area chain of command. Provisions were made, however, for assigning separate security tasks or full responsibility for the division rear area to particular combat units based on the tactical situation. Finally, perhaps realizing that the tactical distinction between front and rear was becoming obscured, the 1968 version of FM 61-100 The Division noted "Enemy operations and threats that endanger successful accomplishment of the mission of the command become operational matters and are beyond the scope of rear area security operations." ³² This continued to be our rear area security doctrine until the early 1980s.

IV. Current U.S. Doctrine

As noted in FM 90-14, "The primary operational purpose for waging the rear battle is to retain freedom of action to conduct the close and deep battles." ³³

FM 90-14 specifies the following as objectives of the rear battle:

- a. Secure rear areas and facilities.
- b. Prevent or minimize enemy interference with command, control, and communications.

c. Prevent or minimize disruption of combat support and combat service support forward.

d. Provide unimpeded movement of friendly units throughout the rear area.

e. Find, fix, and destroy enemy incursions in the rear area.

f. Provide area damage control (ADC) after an attack
34
or incident.

FM 90-14 further specifies that these objectives will be met by applying three principles: 1) economy of force-which emphasizes that combat support and combat service support units must be prepared to defend themselves; 2) responsiveness-which involves immediate reaction and rapid deployment of adequate combat power and ADC support; and 3) unity of effort-which is intended to ensure the protection of
35
the rear area and uninterrupted support of the main effort.

While FM 90-14 emphasizes that the division commander has overall responsibility for the division's rear battle, it also specifies that the commander will appoint a rear battle officer as his representative, based on the factors of METT-T, to control the rear battle. His duties will include:

a. Ensuring that geographical areas of responsibility are clearly defined in the rear area.

b. Ensuring coordination between the G2, G3, and the rear area operations center (RADC).

c. Using the RADC to plan, coordinate, train, and direct the rear battle.

d. Coordinating with the G5 and civil affairs to

integrate host nation support.

e. Being provided with adequate and reliable communication equipment to facilitate command and control of the rear battle.³⁶

The division rear area operations center (RAOC) is intended to act as the focal point for all rear battle operations under the control of the rear battle officer. As the division's tactical center in the rear, it also receives taskings from and provides support to the G3. In fact, the RAOC is an extension of the division's main command post which is located in the rear area. Thus, it must coordinate directly with the G3 who has staff responsibility for planning, monitoring, and directing the division's rear battle. However, it is also tasked to support the rear battle officer who, as the division commander's representative, is also tasked with the responsibility of controlling the rear battle.³⁷

The security plans and operations section (SPO) in the DISCOM is the RAOC's technical counterpart. As FM 90-14 notes:

...the SPO/SOTI is responsible for controlling and administering the technical chain of command to support the forward battle. The RAOC is the tactical center for coordinating the rear battle with the same CS and CSS units. 38

While current doctrine states that each unit in the rear is responsible for its own security, rear battle operations attempt to expand this basic principle through the development of a mutual support system using bases and base clusters. A

base is "A unit or multiunit position that has a definite perimeter." A base cluster is "Combat, combat support, and combat service support units in the rear area...employed based on mission requirements...and grouped together for protection." ³⁹ It should be noted that bases and base clusters (and their associated units) are part of both the tactical and technical chains of command. It is expected that these bases and base clusters will continue to operate within the technical chain of command until they are forced to respond to a threat. At this point, the bases and base clusters will, through the RAOC, turn to the tactical chain of command.

The MPs and engineers are also viewed as major players in the rear battle. MPs are intended to provide a combat link in the rear battle by providing the commander with a readily available quick reaction force as the initial response to a rear area threat. And the engineers are positioned throughout the battlefield and will assist the RAOC, consistent with their mission priorities and availability, in conducting the rear battle and particularly area damage control. ⁴⁰

In those instances when the threat exceeds the capability of the base and base cluster defenses and the MF, a tactical combat force (TCF) may be used. A TCF is a combined arms organization which is given the mission by the commander of defeating a particular rear battle threat. "This may be a unit assigned a RAOC mission from the close-in battle or assigned to the rear battle." ⁴¹

Appendix C contains diagrams summarizing the tactical and

technical chains of command in the division rear. The combined tactical and technical chain of command in the division rear area is shown in Appendix D. There is another key asset, not shown in these diagrams, which is intended to play a critical role in the rear battle. This is the base defense liaison teams (BDLTs). These are assigned to RAOCs based on the geographical area and number of support units. "The teams fulfill many missions, to include coordinating base defense and conducting liaison as directed and required by the RAOC."⁴²

Having identified some of the key players in the command and control of the division's rear battle, attention will turn to an identification of how current doctrine proposes that the division's rear battle should be conducted.

FM 90-14 emphasizes that terrain management, which involves positioning and movement of units and facilities in the rear area, is a key responsibility of the RAOC (and apparently, by implication, of the rear battle officer). The RAOC is expected to exercise rear area terrain management through the following procedures. Actual positioning of units in the rear area will involve many players in the division. It is expected that the RAOC will, in conjunction with the G3, assist in positioning units in the rear areas. This of course will also have to be coordinated with the G4 as well as the DISCOM commander and other combat support and combat service support units operating in the rear area. Current doctrine also notes that the RAOC may recommend to the G3 the

positioning of combat units and reserves in the rear to improve the security of key facilities and locations such as bridges and airfields.

Base and base cluster commanders will notify the RAOC of proposed moves and defensive responsibilities will be adjusted accordingly. The moving units will normally be assisted by the BDLTs which will assist in movement control and brief the moving units on enemy intelligence. FM 90-14 points out that while the moving units are responsible for their own security, they may be augmented with additional security assets based on the enemy threat and the criticality of the mission. Units passing through the division's rear area will be held accountable for their own defense. It is expected that the appropriate echelon will notify the RAOC when its units are passing through. The RAOC will provide current intelligence and coordinate with the unit for possible inclusion in a base or base cluster. The actual movement control will be coordinated by the division's movement control center (MCC) supported by the MPs. If the unit is a potential TCF, it may be used in the division's rear battle with the coordination of its parent organization. While the preceding description has emphasized the role of the bases and base clusters in the division's rear area battle, FM 90-14 notes that the RAOC is responsible for coordinating the security of all units in the division rear.

FM 90-14 identifies three levels of threat as a means of planning the rear battle. In brief, Level I includes enemy agents, sabotage by enemy sympathizers, and terrorism. Level

II includes activities such as Spetsnaz operations, reconnaissance operations, and unconventional missions conducted by company size or smaller parachute and heliborne forces. Finally, the Level III threat encompasses larger heliborne and airborne operations, amphibious operations, infiltration, and ground force operations such as the employment of forward detachments or DMGs. FM 90-14 correctly points out, however, that these activities may not be related or may not occur in any specific order. ⁴⁴

Current doctrine envisions that the combat support and combat service support units in the base and base clusters will be able to handle the Level I threat. The MPs may be required to assist these units in dealing with the Level II threat and will usually be the initial response force for Level III threats. A TCF will normally be required to complete the elimination of a Level III threat. Additionally, the division commander could also employ indirect fires, his reserves, or a TCF given to him from his higher headquarters. The operational plan to include necessary logistical support will be provided by the RAOC. A BDLT team in the area under attack will be placed OPCON to the TCF. The base commander and MPs will retain control of the battle until the TCF arrives and tells the RAOC it is prepared to assume the mission. During its commitment, the TCF will be "placed under the OPCON of the RB officer... and will report to the RAOC as the command and control element for the rear battle." ⁴⁵

The doctrinal description of the division's rear battle

command and control system presented here has included only those players who are viewed as key. FM 90-14 emphasizes that the RAOC must also coordinate with other members of the division staff including the G2, provost marshal, division transportation officer, G5, signal officer, assistant division aviation officer, air defense commanders, and the division chemical officer. Additionally, this review of divisional rear battle doctrine has emphasized those particular procedures which are, again, central to command and control. It is acknowledged that the IPB process, along with the communications network, and the detection effort are critical aspects of rear area security. However, these procedures, along with the internal operations of bases and base clusters and the internal operations of the RAOC are not discussed, first for reasons of brevity, and second since there does not appear to be anything substantively wrong with them.

Based on a review of our current doctrine, it appears that we are trying to establish a high degree of organizational and procedural sophistication as a means of ensuring the security of division rear operations. The implied notion that greater doctrinal sophistication will result in a more successful division rear battle appears questionable in light of the World War II armored division experience. This and related issues are areas which are examined in greater depth in the following section.

V. Analysis

The historical overview presented earlier illustrated how

the World War II armored division successfully applied unity of effort, embodied in the principles of the objective, unity of command, and simplicity in its rear area security effort. However, our current doctrine for the command and control of the rear battle appears to be lacking this very principle.

Prior to conducting a comparative analysis of past and present rear area security doctrine, an important point needs to be made. It is not this paper's intention to suggest that unity of effort and its associated principles of the objective, unity of command, and simplicity should be viewed as inviolable absolutes. History is full of examples where success on the battlefield was, in fact, assured by violating one or several principles of war. However, history also teaches us that these principles have provided effective guides for action and a relatively stable structure for the development and subsequent analysis of theory and doctrine. As such, a lack of unity of effort in our present rear battle doctrine should be regarded more as a symptom of greater substantive problems which are elaborated on under the specific headings of the objective, unity of command, and simplicity.

At the heart of unity of effort is the objective. This provides a focus to the effort. While current doctrine notes that the emphasis of the rear battle should be on the protection of key units, facilities, and locations in the rear; FM 90-14 appears to contradict this by viewing the division rear almost as a homogeneous entity for purposes of

security. This is manifested in the emphasis our doctrine places on terrain management. In fact, the geographical area between the brigade and division rear boundaries almost seems to be regarded as an end in itself rather than as a useful control measure. This is in marked contrast to the view of the rear area adopted by the World War II armored divisions.

The 6th and 7th Armored Divisions did not orient on the security of the rear area as a whole; their effort actually focused on the security of key units in the rear area such as the trains, key facilities such as the DSCP and forward supply dumps, and key locations such as the MSR or a key road network. The division rear area was simply viewed as that portion of the overall division area in which the majority of the division's combat support and combat service support activities were accomplished. This focus of effort on key units, facilities, and locations in the rear area rather than the rear area itself illustrated an understanding and adherence to the principle of the objective.

Current doctrine, as suggested earlier, appears to take a much more geographical approach towards rear area security. This may in part stem from an overemphasis on the geographical aspects of rear operations. In particular, this appears to have caused some confusion regarding the four major activities comprising rear operations - command and control, long range fires, reserves, and combat support. While these activities are normally located in the rear area, they are actually being conducted to support close and deep operations. Yet, FM

90-14 seems to suggest that the collective measures in the division's rear which are adopted to secure these activities and to ensure their freedom of action ought to be considered as a separate issue under the heading of rear battle.

These same four activities were also a part of rear operations for the World War II armored division. Granted, the activities themselves have achieved a level of sophistication today which is arguably an order of magnitude greater than in World War II. In fact, it was this very growth in size and complexity which led to the replacement of the division trains with what is now the DISCOM. Nevertheless, the difficulties associated with integrating these activities into the division's tactical operations on a fluid and nonlinear battlefield and securing them from a very formidable enemy rear area threat were, as seen in the two historical examples presented earlier, considerable. Yet, no apparent need was felt to develop either specific doctrine or a unique command and control system for the conduct of security operations in the division's rear. Security considerations in the division's rear were identical, in principle, to security considerations anywhere else in the division. Specifically, security was viewed as a command responsibility from the division commander down through all his subordinate units. And it was coordinated through the normal command channels. There was no dual chain of command or additional channels of coordination for security in the rear area since it was based on command relationships, not

geographical or technical ones. This conformed to the principle of unity of command.

Present rear battle command and control doctrine seems to violate this principle as well. The rear battle officer, as the division commander's representative, is given the responsibility for integrating the overall security effort in the division's rear area. However, the actual command and associated responsibility for ensuring that units in the rear area accomplish their primary missions lies, as it should, with the parent commander whether he is a headquarters commandant, an artillery battalion commander, or a DISCOM commander. Further, while our current doctrine emphasizes that a unit is responsible for its own security; the proposed role of the rear battle officer seems to confuse the issue by introducing an artificial layer into the command structure. This lack of unity of command is particularly apparent when the dual tactical and technical chain of command in the rear area is examined (see Appendix D).

Even in a static tactical situation, the ability to effectively integrate security in the division's rear area across the wide range of organizational and functional boundaries would be difficult. We know, however, that the future European battlefield will be anything but static. Additionally, we must divorce ourselves from the notion of "the rear battle". A more realistic view is one where a division finds itself simultaneously facing a whole series of rear area threats with individual agents attacking the DISCOM, while heliborne units seize a defile in the rear, and a major

penetration threatens the division's fire support or the reserve's counterattack route. This fluid and confusing tactical situation, coupled with the many disparate rear area activities, does not lend itself to the kind of centralized control offered in our current rear battle doctrine. Our rear battle doctrine implies that by emphasizing control and coordination at the expense of command, manifested in the confusing and duplicative relationship between the rear battle officer, the RAOC, base/base cluster commanders, and the G3 (to name a few), stability can be established in what is an inherently unstable situation.

Interestingly, the rear battle is the only area of the AirLand Battle where we have found it necessary to doctrinally specify a subordinate representative for the division commander who is, in a sense, outside the normal division command structure. The execution of close and deep operations, which also involves the integration of a wide range of activities in a multi-functional and multi-organizational effort, is done by giving specific missions to commanders along with the resources they need to carry their missions out. This same procedure needs to be adopted in the division's rear as well, primarily for security, but also to allow rear area elements to more effectively perform other tactical missions such as securing an MSR or guarding a choke point when required. Indeed, the World War II armored division did not find it necessary to specify a subordinate representative in the rear, rather, unity of command was

maintained by using someone who was already in the division's normal command structure, the division trains commander .

While he coordinated extensively with the G3 and G4 regarding the movement and location of the trains elements; the actual command and control of the trains, including the inherent command responsibility of security, was exercised by the trains commander. The hodgepodge of units and their associated disparate missions was apparently not considered a legitimate excuse for violating the principle of unity of command. And, as noted earlier, not only was the security of the division's rear elements assured, but when the tactical situation required it, the rear elements were also able to perform certain tactical missions as well (albeit at the expense of diminishing their ability to execute their primary missions). Unity of command in the rear was accomplished not only by using an existing command structure, but also by assigning or attaching all other divisional units to the trains commander which were not assigned or attached to the combat or reserve commands or directly subordinate to the division. In addition to supporting the forward units, as a tactical commander, the trains commander was also in a position to execute any additional stated or implied missions when the tactical situation required it. The same cannot be said regarding the role envisioned for the rear battle officer.

An examination of the proposed role for the rear battle officer suggests someone who is much more a landlord than a commander. The largely semantical objection that the division

commander is the true division rear battle commander misses the point. The issue is not titles, but responsibility and the associated authority that comes with it. The crux of the problem is that the rear battle officer, in point of fact, commands nothing, either in the way of forces (with the possible exception of a TCF) or equally important, in the way of a headquarters and staff element. Hence, his role is more a controller than a commander. This suggests a lack of command as much as a lack of unity of command. In fact, it is the control as opposed to the command of the rear battle which appears to be the focus in our proposed rear battle command and control doctrine.

This is most apparent by noting that the RAOC and not the rear battle officer is viewed as the focal point of the division's rear battle. Although the RAOC is OPCON to the rear battle officer, it receives its taskings, as the division rear's tactical CP, from the G3. Setting aside the issue of whether the RAOC will even arrive in the division prior to the outbreak of hostilities, there is something fundamentally wrong with a staff function which, by all appearances, is shared by the G3 and the rear battle officer. Again, there is no RAOC equivalent staff for close and deep operations, rather, control is exercised through the existing commanders and their staffs. Why should the rear battle be an exception? Using the RAOC as a focal point of the rear battle is only a symptom of a greater problem alluded to earlier. Specifically, control can never be a substitute for command.

Not only does this violate the principle of unity of command, but it invariably results in a reduction in simplicity.

Simplicity, the third element in unity of effort, was also present in the rear battle command and control system adopted by the World War II armored division. By having his own headquarters company and staff, the trains commander was able to develop habitual relationships and procedures for the command and control in the rear area. Additionally, the use of the DSCP provided a simple, but effective means of integrating the technical and tactical aspects of rear area operations. Finally, by making one commander responsible for positioning, movement, and security of those division elements in the rear area which were not assigned or attached to the other commands or under division control, the need for extensive coordination across organizational and functional boundaries was reduced. This emphasis on command rather than control helped achieve simplicity in the command and control of the rear area security effort.

As is the case with the objective and unity of effort, simplicity is missing from current rear battle command and control doctrine. Many of the problems addressed earlier regarding the objective and unity of command also violate the principle of simplicity. These include the increased coordination across organizational and functional boundaries for positioning, movement, and security, the emphasis on control rather than command, and the lack of an organic headquarters and staff for the rear battle officer. In addition, there seems to be a significant amount of command

and staff duplication which could be eliminated by combining some of the staff functions and eliminating some of the dual command chains in the rear battle command and control structure.

VI. Conclusions

Soviet doctrine emphasizes the need to employ sizeable conventional and unconventional forces in the enemy's rear as a means of disrupting the enemy's operations in depth. This, coupled with the fluid and nonlinear nature of a future war in Europe is a cause for concern regarding the ability of units in the division rear to perform their primary mission. Critical units, activities, and locations in the rear must be secure to ensure continuous forward support and to maintain the command's freedom of action to conduct close and deep operations. Essential to this effort is a simple but effective command and control system for security in the rear area.

History has demonstrated that a key ingredient for providing security in the rear area is unity of effort. By applying unity of effort in their rear area security operations, the 6th and 7th Armored Divisions were able to assure themselves of effective forward support and freedom of action in the face of formidable enemy threats to their rear. Unfortunately, while our present rear battle doctrine espouses the need for unity of effort as one of its three rear battle principles, it appears to be lacking this very principle.

US rear battle command and control doctrine must reorient its thinking on the rear battle. The security of key units, facilities, and locations in the rear area which are essential to the accomplishment of the division's mission should be the focus of rear area security, not the security of the rear area as a whole. Attempting to integrate the division's rear security efforts across organizational and functional boundaries appears at best to be unrealistic and at worst may undermine the ability of these various units to accomplish their primary missions. What is required is a simple system which is based on command and not control in the division rear.

Security has been and must continue to be a command responsibility. Yet, the emphasis on control rather than command, as evidenced by the confusing and redundant relationships in our current rear battle doctrine, violates this. US rear battle doctrine must restore the primacy of command to the rear battle command and control system. What is required is a rear brigade equivalent commander (for lack of an adequate title). Consistent with the emphasis on command, those units in the rear area not assigned or attached to one of the four maneuver brigades or directly under division control should be assigned or attached to this commander. This would fix responsibility for positioning, movement, and security where it belongs—with a single commander. Other elements in the rear such as reserves and artillery would continue to be responsible for their own security, but would effect coordination with the rear brigade

commander. Additionally, the inherent missions of surveillance, reconnaissance, and detection, along with the execution of other missions in the division's rear area such as securing MSRs, key terrain, or facilities could also be given to this commander. Thus, the focus of the rear brigade commander would be on the security of his assigned and attached units and the execution of those additional tactical missions in the division rear which he was assigned, not the rear area as a whole. This would of course require that additional combat and/or combat support units be attached or placed OPCON (or be given the appropriate support relationship) to the rear brigade commander. Further, the rear brigade commander would have to be provided with his own headquarters and staff. As a result of this reorganization, it is envisioned that many of the duplicative staff and command functions which currently seem to exist would be eliminated.

It seems probable that since his organization would consist largely of logistical units, the rear brigade commander would be a key division logistics operator. At the same time, again assuming he was provided with adequate resources, he would also play a critical tactical role in the rear area based on the division's overall mission. This appears increasingly likely given the nature of the threat and the anticipated fluid and nonlinear character of the future AirLand Battlefield.

It may appear to the reader that this paper is making a

case for the DISCOM commander or for that matter, the ADC-S to assume the role of the rear brigade commander. This is not the case. It is not the intent of this paper to specify either by name, title, or rank, who the rear brigade commander should be or what his headquarters and staff element ought to consist of. These issues involve both questions of doctrine and force structure and are beyond the scope of this paper. Rather, the intent of this paper has been to identify what is perceived to be a significant deficiency in our current division rear battle command and control doctrine.

The need to support close and deep operations and maintain the command's freedom of action, coupled with the formidable Soviet rear area threat and the rapid and nonlinear nature of future war, pose a significant challenge. In light of this, what is needed is an effective command and control doctrine for rear area security which does not add to this complexity. Adding an additional layer of command and control does just the opposite. The apparent attempt of our rear battle doctrine to centralize the division's rear area security effort across organizational and functional boundaries in the face of what will probably be a very decentralized and disjointed rear battle is not realistic. The experiences of the 6th and 7th Armored Divisions in World War II demonstrated that the key to rear area security is a simple system which relies on command and not control. We need to go back to the basics with our current rear battle command and control doctrine.

APPENDIX A

The 6th Armored Division in the Exploitation

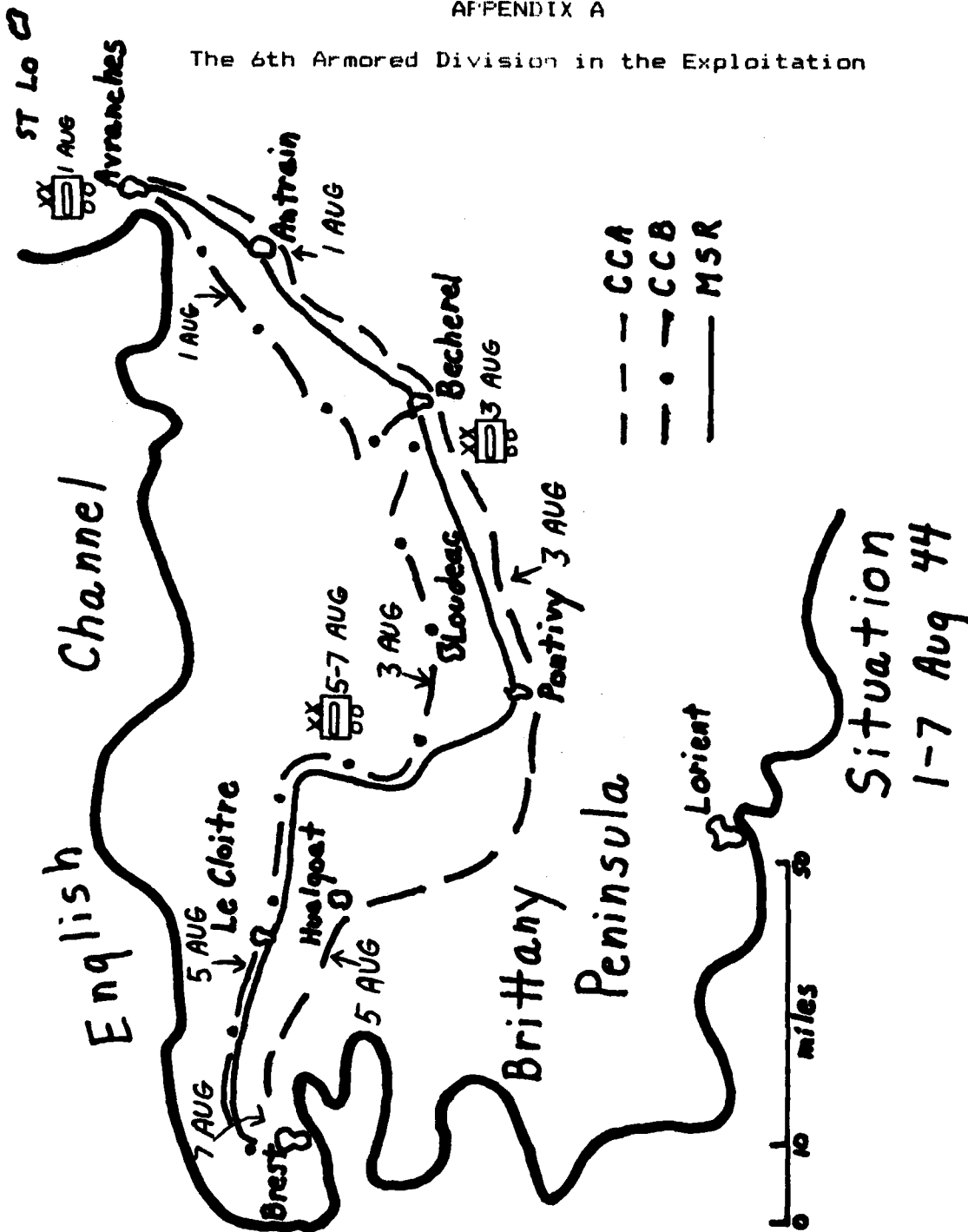

Source: Brame, LTC Wayne et al. "Super Sixth in Exploitation" (an unpublished student research report). The Armored School, Fort Knox, KY., 1949.

APPENDIX B

The 7th Armored Division in the Defense of ST. Vith

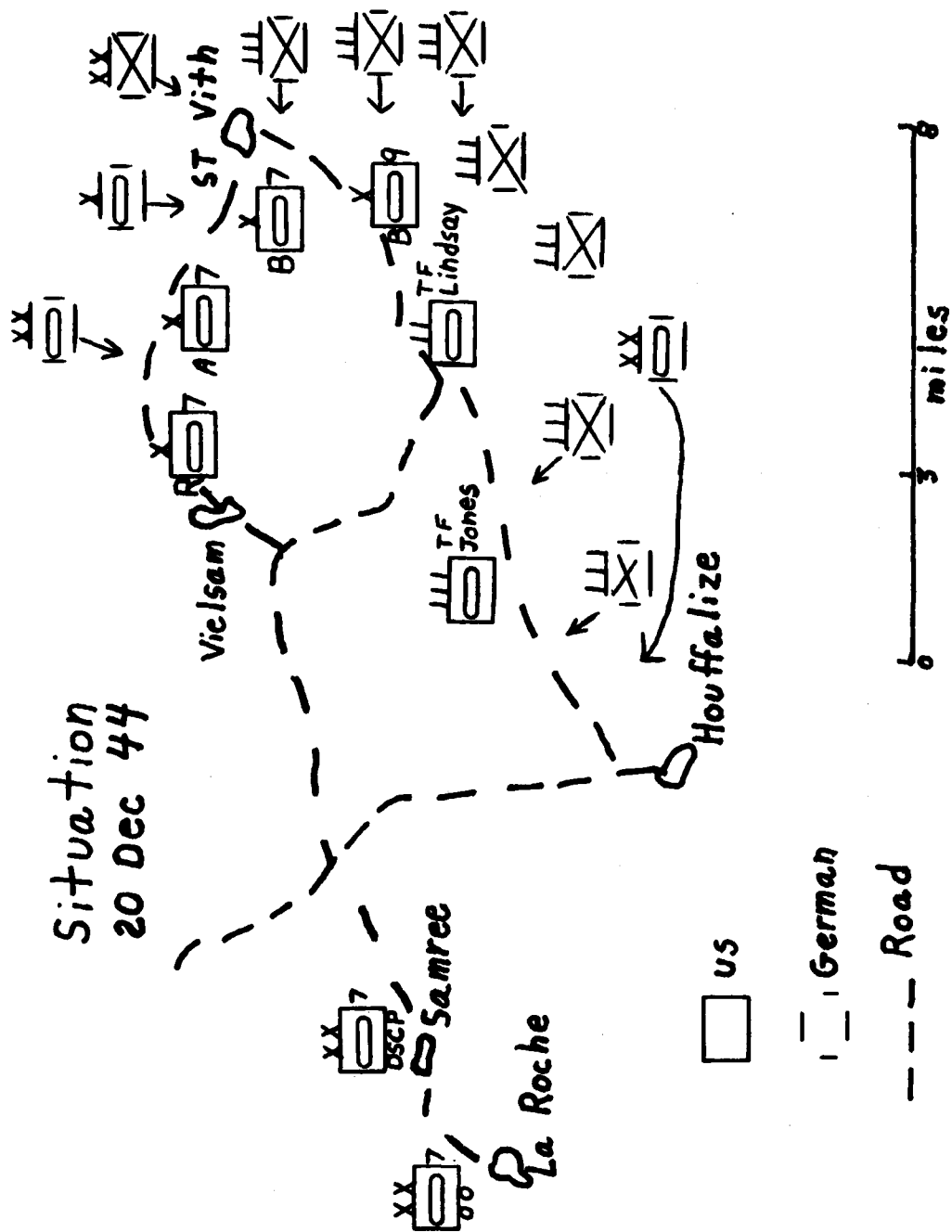

Source: Research and Evaluation Division. "The Defense of ST. Vith Belgium 17-23 Dec 1944". The Armored School. Fort Knox, KY., 1949.

APPENDIX C

Division Rear Area Tactical and Technical Chains of Command

Tactical Chain of Command:

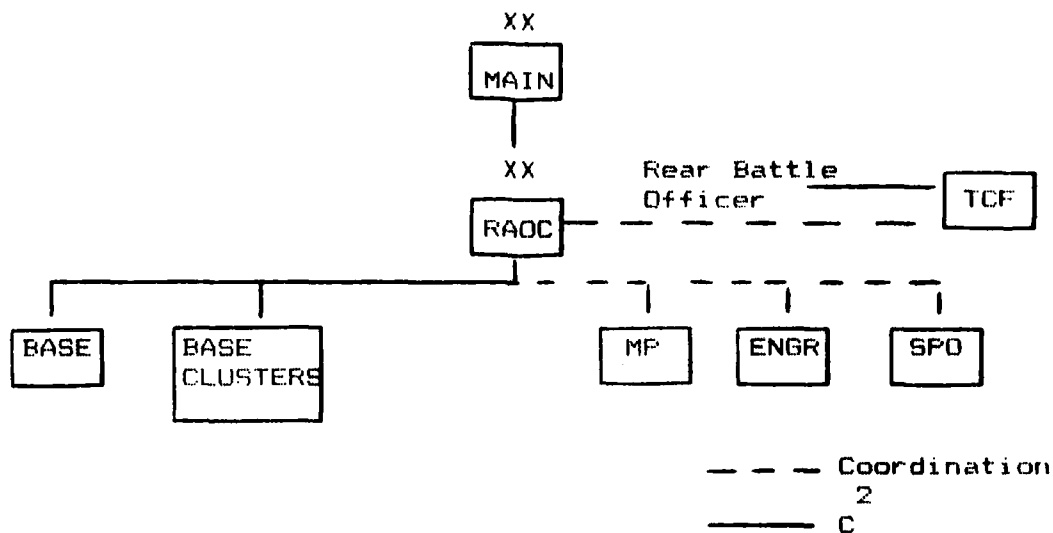

Technical Chain of Command:

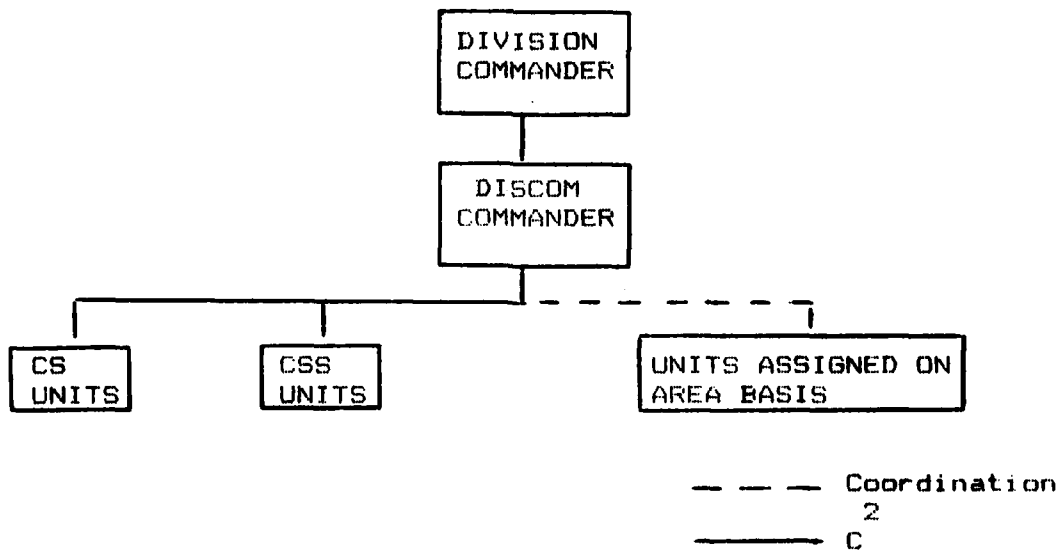

Source: These are composites from two sources. One is FM 90-14 Rear Battle, pp. 3-2 and 3-3. The other is a general officer briefing given on 24 October, 1985 at Fort Leavenworth, KS. by Major Mike Grove of the 34th RAOC, Iowa National Guard (V Corp's RAOC).

APPENDIX D

Combined Tactical and Technical Chain of Command
in the Division Rear Area

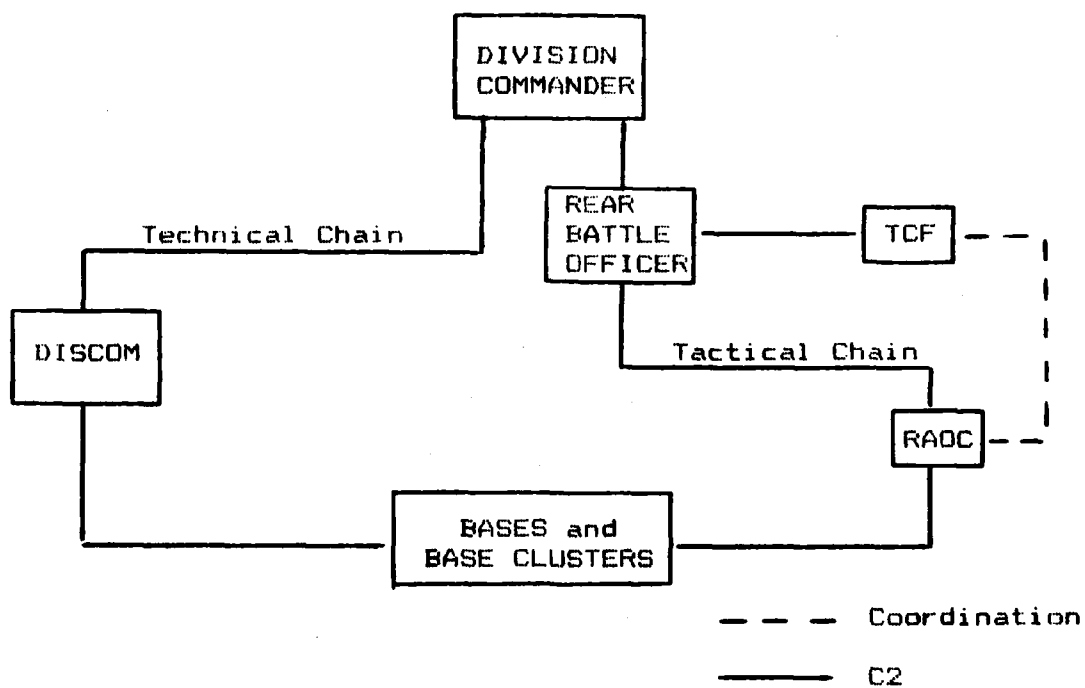

Source: This is also a composite from Major Grove's briefing and FM 90-14, p. 3-3.

ENDNOTES

1. U.S. Department of the Army, Operations, FM 100-5 (Draft) (Washington, D.C.: U.S. Government Printing Office, 1985), p. 3-41.
2. Ibid. p. 2-19.
3. Ibid. p. 3-32.
4. U.S. Department of the Army, Rear Battle, FM 90-14 (Washington, D.C.: U.S. Government Printing Office, 1985), p. i.
5. Field Manual 100-5 (Draft), p. 2-25.
6. The remainder of this section, unless otherwise indicated, is a summary of many sources. The primary ones are listed below. C.N. Donnelly, "Operations in the Enemy Rear: Soviet Doctrine and Tactics," International Defense Review (January 1980) p. 160. MAJ Robert E. Bort, "Air Assault Brigades: New Element in the Soviet Desant Force Structure," Military Review (October 1983) p. 21. CPT Henry S. Whittier, Jr., "Soviet Special Operations/Partisan Warfare: Implications for Today," Military Review (January 1979) p. 48. V. Suvorov, "Spetsnaz: the Soviet Union's Special Forces," Military Review (March 1984) p. 30.
7. The reader is referred to the following sources for a detailed description of the actions of Soviet bypassed and partisan forces during World War II. All of these are U.S. Department of the Army Historical Studies published by the U.S. Government Printing Office. Small Unit Actions During the German Campaign in Russia, DA Pamphlet 20-269, 1953. Rear Area Security in Russia: The Soviet Second Front Behind the German Lines, DA Pamphlet 20-240, 1951. Military Improvisations During the Russian Campaign, DA Pamphlet 20-201, 1951. Russian Combat Methods in World War II, DA Pamphlet 20-230, 1950.
8. Y. Novikov and F. Sverdlov, Manoeuvre in Modern Land Warfare (Progress Publishers, Moscow 1972) translation by Gennady Khmelev.
9. U.S. Department of the Army, Armored Division and Combat Command, FM 17-100 (Washington, D.C.: U.S. Government Printing Office, 1949), Chapter 1.
10. U.S. Department of the Army, Logistics, Armored Division, FM 17-50 (Washington, D.C.: U.S. Government Printing Office, 1951), Chapter 2. It should be noted here that while these editions of FM 17-10 and FM 17-50 were published after World War II, the doctrine in them was in large part dictated by the experiences of US armored divisions during the war.

11. Ibid. p.49.
12. Ibid. pp. 49-51.
13. Field Manual 17-100, p. 17.
14. Field Manual 17-50, pp. 5-8.
15. LTC Creighton W. Abrams, The Armored Division G-4: Student Research Directive, (Command and General Staff College: Fort Leavenworth, Ks., 1948), p. 3.
16. Field Manual 17-50, pp. 74-75.
17. U.S. Department of the Army, Operations, FM 100-5 (Washington, D.C.: U.S. Government Printing Office, 1944), p. 60.
18. Field Manual 17-50, p. 123.
19. Ibid. pp. 123-129.
20. LTC Wayne W. Brame, et al., Super Sixth in the Exploitation: Student Research Project, (The Armor School: Fort Knox, Ky., 1949), pp. 68-88 and 120-126.
21. U.S. War Department, Hq. 6th Armored Division, ETO, "G-4 Report of the Brittany Campaign, 29 July-14 August," pp. 1-4.
22. LTC Brame, et al., pp. 135-175.
23. G-4 Report of the Brittany Campaign, pp.4-5.
24. LTC Brame, et al., p. 156.
25. U.S. War Department, Hq., 7th Armored Division, ETO, Distinguished Unit Citation, 1947, p. 16.
26. Research and Evaluation Division, The Defense of St. Vith, Belgium 17-23 December 1944 (The Armored School: Fort Knox, Ky., 1949), p. 34.
27. MAJ Gregory Fontenot, The Lucky Seventh in the Bulge: A Case Study for the AirLand Battle (School of Advanced Military Studies: Fort Leavenworth, Ks., 1985), p. 62.
28. Ibid. p. 63.
29. Distinguished Unit Citation, p. 25.
30. MAJ Gregory Fontenot, p. 88.
31. For a review of how this transition occurred, the reader is referred to: Headquarters, US Army Combat Development

Experimentation Center, Division Service Command Medium Division-MOMAR I (Headquarters US Continental Army Command, Fort Monroe, Va., 1960), Headquarters 2d Armored Division Trains, Subject: Div-Log Command (letter to CG, Fort Leavenworth, Ks., 1956), and U.S. Department of the Army, The Division, FM 61-100 (Washington: U.S. Government Printing Office, 1962).

32. U.S. Department of the Army, The Division, FM 61-100 (Washington: U.S. Government Printing Office, 1968), p. 7-28.

33. Field Manual 90-14, p. 2-1.

34. Ibid. p. 2-2

35. Ibid. pp. 2-3 to 2-4. FM 90-14 does not define unity of effort. It merely states what unity of effort is intended to accomplish.

36. Ibid. pp. 2-3 to 2-3.

37. Ibid. pp. 3-1 to 3-5.

38. Ibid. p. 3-23. The security operations and intelligence section (SOTI) is the SPOs counterpart in the COSCOM.

39. Ibid. p. Glossary 1.

40. Ibid. p. 3-1.

41. Ibid. p. 3-20.

42. Ibid. p. 3-12.

43. Ibid. pp. 3-13, 3-17 to 3-18, 5-4 to 5-6. Also U.S. Department of the Army, Combat Service Support Operations: Division, FM 63-2J (Washington, D.C.:U.S. Government Printing Office, 1984), p.3-7.

44. FM 90-14, pp. 1-2 to 1-7. It should be noted here that the utility of this categorization scheme has been questioned by many. In fact, V Corps has adopted the practice of using two categorizations; either a unit can or cannot deal with the threat. The size or type of threat is viewed as somewhat academic. The source is LTC Ken Carlson, a former member of V Corps G3 plans and currently a member of the faculty of the School of Advanced Military Studies, Fort Leavenworth, KS.

45. Ibid. p.3-22.

46. In a discussion with Major Grove (34th RADC, Iowa National Guard) on 24 October 1985, he pointed out that division RADCs had only recently been formally approved as part of the army force structure. Additionally, all division RADCs would continue to be National Guard units which might or might not

arrive prior to hostilities. As a result, Major Grove stated that some divisions had developed an ad hoc RAOC from existing assets to meet their rear battle requirements.

BIBLIOGRAPHY

Books and Theses

- Durbin, MAJ J.J. An Analysis of Rear Area Security in the ROAD Division. MMAS Thesis. Command and General Staff College, Fort Leavenworth, KS., 1968.
- Fontenot, MAJ Gregory. The Lucky Seventh in the Bulge: A Case Study for the AirLand Battle. MMAS Thesis. School of Advanced Military Studies, Fort Leavenworth, KS., 1985.
- Horrocks, Sir Brian. Corps Commander. New York: Scribner, 1977.
- Novikov, Y. and F. Sverdlov. Manoeuvre in Modern Land Warfare. Translated by Gennady Khmelev. Moscow: Progress Publishers, 1972.
- Reznichenko, V.G. Tactics. Edited machine translation. Foreign Technology Division, Air Force Systems Command, 1967.
- Slepenkov, D.K. Army Operations. Edited machine translation. Foreign Technology Division, Air Force Systems Command, 1983.
- Wray, MAJ Timothy A. Standing East: German Defense Doctrine on the Russian Front During the Second World War. MMAS Thesis. Command and General Staff College, Fort Leavenworth, KS., 1983.

Government Documents

- U.S. Department of the Army. Historical Study. Military Improvisations During the Russian Campaign, DA Pamphlet 20-201. Washington: U.S. Government Printing Office, 1951.
- Historical Study. Russian Combat Methods in World War II, DA Pamphlet 20-230. Washington: U.S. Government Printing Office, 1950.
- Historical Study. Rear Area Security in Russia: The Soviet Second Front Behind the German Lines, DA Pamphlet 20-240. Washington: U.S. Government Printing Office, 1951.
- Historical Study. Small Unit Actions, DA Pamphlet 20-269. Washington: U.S. Government Printing Office, 1953.
- Logistics, Armored Division, FM 17-50. Washington: U.S. Government Printing Office, 1951.

- Armored Division and Combat Command, FM 17-100. Washington: U.S. Government Printing Office, 1949.
- Rear Area Protection (RAP) Operations, FM 17-105. Washington: U.S. Government Printing Office, 1970.
- The Division Support Command, FM 54-2. Washington: U.S. Government Printing Office, 1965.
- The Division, FM 61-100. Washington: U.S. Government Printing Office, 1962.
- The Division, FM 61-100. Washington: U.S. Government Printing Office, 1968.
- Combat Service Support Operations-Division, FM 63-2J. Washington: U.S. Government Printing Office, 1984.
- Rear Battle, FM 90-14. Washington: U.S. Government Printing Office, 1985.
- The Soviet Army: Operations and Tactics, FM 100-2-1. Washington: U.S. Government Printing Office, 1984.
- Operations, FM 100-5. Washington: U.S. Government Printing Office, 1944.
- Operations, FM 100-5. Washington: U.S. Government Printing Office, 1982.
- Operations, FM 100-5 (Draft). Washington: U.S. Government Printing Office, 1985.
- U.S. Army Training and Doctrine Command. US Army Operational Concept for Rear Area Protection, TRADOC FAM 525-30. Fort Monroe, VA., 1983.
- U.S. Army Command and General Staff College. Armored and Mechanized Division and Brigade Operations, FC 71-100. Fort Leavenworth, KS., 1984.
- U.S. Army Combat Development Experimentation Center. Division Service Command Medium Division: MOMAR I. Fort Ord, CA., 1960.

Articles and Periodicals

- Best, Dale B. "Soviet Motorized Rifle Battalion Heliborne Assault." Air Defense Magazine. Jan-Mar 82, pp. 30-31.
- Bort, MAJ Roger E. "Air Assault Brigades: New Element in the Soviet Desant Force Structure." Military Review. Oct 83, pp. 21-38.

- Donnelly, C.N. "Operations in the Enemy Rear: Soviet Doctrine and Tactics." International Defense Review. Jan 80, pp. 160-166.
- Glantz, LTC David M. "The Soviet Airborne Experience." Research Survey Number 4. Combat Studies Institute, Fort Leavenworth, KS., Nov 84.
- Hines, LTC J.G. "The Soviet Conventional Offensive in Europe." Military Review. Apr 84, pp. 2-29.
- LTC Leushev. "In Co-operation with a Tactical Airborne Assault Landing." Vo Vest. Jul 83, pp.34-37.
- Myagkov, Alesksei. "The Soviet Union's Special Forces." Soviet Analysis. Jan 80, pp.3-5.
- Samojlenko, COL Ya. "A Raid by Parachutists." Vo Vest. Aug 83, pp. 26-29.
- Stephenson, MAJ George "Protecting the Brigade Support Area." Army Logistician. May-Jun 83, pp. 20-23.
- Suvorov, V. "Spetsnaz:the Soviet Union's Special Forces." Military Review. Mar 84, pp.30-46.
- Whitier, CPT Henry S. "Soviet Special Operations/Partisan Warfare: Implications for Today." Military Review. Jan 79, pp. 48-58.

Unpublished Documents

- Abrams, LTC Creighton W. "Division Logistics, the Armored Division G-4." Student Research Directive. Command and General Staff College, Fort Leavenworth, KS., 1948.
- Brame, LTC Wayne et al. "Super Sixth in Exploitation (6th Armored Division, Normandy to Brest)." Student Research Report. The Armored School, Fort Knox, KY., 1949.
- Harris, LTC Arthur C. et al. "Armor in Exploitation." Student Research Report. The Armored School, Fort Knox, KY., 1950.
- Lawson, CPT William F. et al. "Security of the Trains of Armored Units Against Guerilla Type Activity." Student Research Report. The Armored School, Fort Knox, KY., 1952.
- McLemore, COL Oran Fred. "Rear Area Protection at Corps and Division: Is it Enough." Student Essay. U.S. Army War College, Carlisle Barracks, PA., 1984.
- Research and Evaluation Division. "The Defense of ST. Vith, Belgium 17-23 Dec 1944." The Armored School. Fort Knox,

KY., 1949.

Ring, LTC William. "Manual for G4, Armored Division." Student Research Directive. Command and General Staff College, Fort Leavenworth, KS., 1948.

Ritchie, COL Paul J. Letter to CG, Fort Leavenworth, KS. Attn: the Commandant. Subject: Div-Log Command. Headquarters, 2D Armored Division Trains. 24 August, 1956.

U.S. War Department, U.S. Army Ground Forces. 6th Armored Division, "G-4 Report of the Brittany Campaign, 29 July-14 August 1944."

_____. 6th Armored Division, "Operations of 6th Armored Division Trains During the Brittany Campaign," 1944.

_____. 7th Armored Division, "After Action Report, December 1944."

_____. 7th Armored Division, "Distinguished Unit Citation," 1947.

END

DTIC

6-86