

MICROCOPY RESOLUTION TEST CHART
1963-A

AD-A168 132

2

NPS-61-86-012

NAVAL POSTGRADUATE SCHOOL

Monterey, California



DTIC
ELECTE
MAY 29 1986
S D
D

SHIPBOARD OBSERVATIONS OF MEAN
AND TURBULENT ATMOSPHERIC
SURFACE LAYER QUANTITIES
SCCCAMP DATA REPORT, PART I

by

C. E. Skupniewicz, S. Borrmann, C. Fellbaum,
W. J. Shaw, C. A. Vaucher, and G. T. Vaucher

May 1986

Approved for public release; distribution unlimited

Prepared for: South Central Coast Cooperative Monitoring Program
(SCCCAMP)
727 West Seventh Street, Suite 850
Los Angeles, California 90017

00 5 103

NAVAL POSTGRADUATE SCHOOL
Monterey, California

Rear Admiral R. H. Shumaker
Superintendent

D. A. Schrady
Provost

The work reported herein was supported in part by Western
Oil and Gas Association.

Reproduction of all or part of this report is authorized.

This report was prepared by:

C. E. SKUPNIEWICZ
Physical Scientist

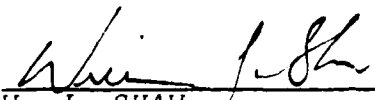

W. J. SHAW
Assistant Professor

Approved:

G. E. SCHACHER
Chairman, Physics Department

R. J. RENARD
Chairman, Meteorology Dept.

Released by:

J. N. DYER
Dean of Science and Engineering

UNCLASSIFIED

SECURITY CLASSIFICATION OF THIS PAGE (When Data Entered)

REPORT DOCUMENTATION PAGE		READ INSTRUCTIONS BEFORE COMPLETING FORM
1. REPORT NUMBER NPS-61-86-012	2. GOVT ACCESSION NO.	3. RECIPIENT'S CATALOG NUMBER
4. TITLE (and Subtitle) Shipboard Observations of Mean and Turbulent Atmospheric Surface Layer Quantities: SCCAMP Data Report, Part I		5. TYPE OF REPORT & PERIOD COVERED July 1985 - Jan 1986
		6. PERFORMING ORG. REPORT NUMBER
7. AUTHOR(s) C. E. Skupneiwicz, S. Bormann, C. Fellbaum, W. J. Shaw, C. A. Vaucher, and G. T. Vaucher		8. CONTRACT OR GRANT NUMBER(s)
9. PERFORMING ORGANIZATION NAME AND ADDRESS Naval Postgraduate School Code 61 Monterey, CA 93943		10. PROGRAM ELEMENT, PROJECT, TASK AREA & WORK UNIT NUMBERS
11. CONTROLLING OFFICE NAME AND ADDRESS Western Oil and Gas Association 727 West Seventh Street, Suite 850 Los Angeles, California 90017		12. REPORT DATE May 1986
		13. NUMBER OF PAGES
14. MONITORING AGENCY NAME & ADDRESS (if different from Controlling Office)		15. SECURITY CLASS. (of this report)
		15a. DECLASSIFICATION/DOWNGRADING SCHEDULE
16. DISTRIBUTION STATEMENT (of this Report)		
17. DISTRIBUTION STATEMENT (of the abstract entered in Block 20, if different from Report) Approved for public release; distribution unlimited		
18. SUPPLEMENTARY NOTES		
19. KEY WORDS (Continue on reverse side if necessary and identify by block number) Turbulence diffusion, measurements Santa Barbara Channel		
20. ABSTRACT (Continue on reverse side if necessary and identify by block number) 3 weeks of aerometric observations from a shipboard platform are described and analyzed to obtain surface layer quantities relevant to the dispersion of pollutants from offshore oil operations. Momentum, heat, and moisture flux were estimated with two different methods: the dissipation technique and bulk parameterizations. Diffusion scale turbulence was measured with bivariate anemometers and estimates of ship motion contributions to these measurements were performed.		

DD FORM 1473
1 JAN 73EDITION OF 1 NOV 68 IS OBSOLETE
S/N 0102-LF-014-6601

UNCLASSIFIED

SECURITY CLASSIFICATION OF THIS PAGE (When Data Entered)

SHIPBOARD OBSERVATIONS OF
MEAN AND TURBULENT ATMOSPHERIC
SURFACE LAYER QUANTITIES:
SCCCAMP DATA REPORT, PART I

by: C. E. Skupniewicz, S. Borrmann, C. Fellbaum,
W. J. Shaw, C. A. Vaucher, and G. T. Vaucher

Prepared for:

South Central Coast Cooperative Monitoring Program

727 West Seventh Street, Suite 850

Los Angeles, California 90017

Attn: Mr. Thomas Cornwell, Environmental Coordinator

+ All authors from the Environmental Physics Group at the Naval
Postgraduate School, Monterey, CA 93943. Phone (408)646-2563

++ This report has not been reviewed or approved by the
Participants. Release of this report for committee review
does not indicate that the Participants have agreed to or
approved its contents. Following review of the report, the
Participants may approve or disapprove all or portions of the
report.

ABSTRACT

3 weeks of aerometric observations from a shipboard platform are described and analyzed to obtain surface layer quantities relevant to the dispersion of pollutants from offshore oil operations. Momentum, heat, and moisture flux were estimated with two different methods: the dissipation technique and bulk parameterizations. Diffusion scale turbulence was measured with bivane anemometers and estimates of ship motion contributions to these measurements were performed.

TABLE OF CONTENTS

LIST OF SYMBOLS AND ACRONYMS.....1

I. Introduction.....3

II. Measurement System.....4

a. Instruments.....4

b. Data Logging.....7

c. Data Content.....8

III. Sampling Patterns/Field Operations.....14

IV. Quality Assurance/Data Processing and Editing.....16

V. Data Presentation.....18

ACKNOWLEDGEMENTS.....21

TABLES.....22

ILLUSTRATIONS.....44

REFERENCES.....59

APPENDIX A. Removing Ship Motion Contributions from.....60

Measured Bivane Turbulence

Accession For	
NTIS CRA&I	<input checked="" type="checkbox"/>
DTIC TAB	<input type="checkbox"/>
Unannounced	<input type="checkbox"/>
Justification	
By	
Distribution /	
Availability Codes	
Dist	Avail and/or Special
A-1	



LIST OF SYMBOLS AND ACRONYMS
(in order of presentation)

-acronyms-

SCCCAMP: South Central Coast Cooperative Aerometric Monitoring Program

EPG: Environmental Physics Group

NPS: Naval Postgraduate School

DAS: Data Acquisition System

-symbols-

$\frac{1}{2}q^2$ kinetic energy ($= \frac{1}{2}(u^2 + v^2 + w^2)$)

U mean wind speed

U_{rel} relative mean wind speed

ϵ turbulent dissipation rate

$S_u(k)$ power spectral density of the u component at frequency k.

u_* friction velocity

k_v von Karman's constant ($=.4$)

$\phi\epsilon(z/L)$ dissipation stability function

L Obukhov length

V hot wire voltage

T absolute temperature

θ potential temperature referenced to sea level pressure
($=T + .00976z$)

θ_s absolute surface potential temperature

g acceleration due to gravity

q specific humidity

$\phi_m(z/L)$ stability correction for dimensionless wind shear

$\phi_t(z/L)$ stability correction for dimensionless temperature gradient
 $\phi_q(z/L)$ stability correction for dimensionless humidity gradient
 z_{om} roughness length for momentum
 z_{ot} roughness length for temperature ($2 \times 10^{-5}m$)
 z_{oq} roughness length for humidity ($2 \times 10^{-5}m$)
 T^* convective temperature scale
 T^*_v virtual convective temperature scale
 q^* humidity scale
 C_d momentum exchange coefficient
 ρ air density
 c_p specific heat of dry air
 L_v latent heat of evaporation
 Φ pitch angle
 Ψ roll angle
 Ω yaw angle
 U_s ship speed
 u_n instantaneous along-ship wind component in ship coordinates (fore-aft) where n references a particular source (i.e. r refers to "rotational")
 v_n instantaneous cross-ship wind component in ship coordinate (perpendicular to fore-aft direction)
 w_n instantaneous vertical component of wind
 A_{rel} relative horizontal wind direction in ship coordinates
 $(A)_{RMS}$ standard deviation of horizontal wind direction
 $(E)_{RMS}$ standard deviation of vertical wind direction
 $(S)_{RMS}$ standard deviation of absolute wind speed

I. INTRODUCTION

The South Central Coast Cooperative Aerometric Monitoring Program (SCCCAMP) was undertaken in the fall of 1985 with the objective to develop data to use as a basis for assessing the impact of the offshore petroleum industry on air quality in the south-central California coastal area. The Environmental Physics Group (EPG) at the Naval Postgraduate School in Monterey, California (NPS) operated the Research Vessel Acania in the Santa Barbara Channel area for a major portion of SCCCAMP and this report summarizes those operations. The R/V Acania was the only ship based measurement platform involved in SCCCAMP, and therefore its data is an important subset of the SCCCAMP data archive. This report specifically summarizes the atmospheric surface layer mean and turbulent quantities measured aboard the R/V Acania. A series of radiosonde launches concurrently performed from the ship is described in another NPS report (Shaw et al., 1986).

II. THE MEASUREMENT SYSTEM

Instruments

Basic quantities measured at two levels (-5 and 20 m) were mean wind, turbulent wind, high frequency turbulent wind, and mean dew point temperatures. Mean temperatures were measured at three levels (sea surface, 5 and 20 m). Accurate measures of ship speed and heading were recorded. Ship pitch, roll, and accelerations were also measured from the ships's center of gravity. Table 1 supplies instrument specifications. Figure 1 displays the R/V Acania instrumentation layout for SCCAMP. Air flow to all tower instruments was virtually undisturbed as long as the relative wind direction was less than plus or minus 120 degrees from the bow. Larger relative wind directions (winds from a stern) result in flow distortion and these data were not recorded.

Four independent measurements of wind speed and direction provided adequate backup and redundancy checks at each of the two measurement levels. The cups are of the optical chopper type while the standard vane utilizes a 360 degree potentiometer for azimuthal wind direction measurements. The bivane consists of a gimbaled vane with a propeller anemometer mounted on the nose of the vane. The anemometer is the generator type. An additional potentiometer linked to the vane provides elevation as well as azimuthal angles. The sea surface temperature thermometer was suspended from a boom extending from the starboard beam (see figure 1). The thermal mass was lowered to a position just below the sea surface as the ship was steaming at measurement speeds. Air temperature thermometers and dew point thermometers were

shielded from radiation and aspirated. The dew point is measured directly by cooling a mirror (which closes an optical circuit) to the dew point temperature. At this temperature dew forms on the mirror and the circuit is opened. A servo loop maintains this equilibrium and the mirror temperature is measured. All temperature measurements rely on the well-known relationship between platinum conductance and temperature as the principle of operation, and were measured with four-wire resistance techniques to eliminate lead effects. All thermometers have been recently calibrated in a variable temperature water bath.

Ship speed was measured with an acoustic doppler velocity profiler maintained by the Oceanography Department at NPS. This device calculates velocity from the doppler shifted signal returned from depths where the water can be considered at rest. A fairly large accuracy is obtained from a relatively short integration time (see table 1). Ship heading was obtained by interfacing to the ship's gyro. The gyro is maintained by the crew of the RV Acania.

A specially designed pendulum/accelerometer instrument was installed near the ship's center of gravity. This device measured both absolute ship position relative to earth coordinates and rate change of that position. Accelerations along earth coordinates were also measured. While contractual agreements did not specifically require these measurements, EPG-NPS included this instrument in the measurement array as a development tool for estimating ship motion effects on turbulence measurements. Raw outputs and calculations are supplied in the SCCAMP data set.

A schematic of the pendulum device is shown in figure 2. A tri-directional accelerometer is suspended from a "joystick" device which is linked to 2 potentiometers. The arm length of the pendulum is adjusted to minimize oscillations. The pot outputs are measured directly for pitch and roll positions. These analog outputs are also differentiated, giving rate pitch and rate roll. The accelerometer output is integrated to produce velocity components. Since the joystick "automatically" aligns itself with the earth's gravitational field, two of the accelerometer outputs are free from "gravity contamination" and the third need only be corrected by a constant (neglecting oscillations and misalignment).

The hot wire anemometer measures wind speed by maintaining a balance between electrical energy necessary to maintain the wire at a constant resistance and energy lost through forced convective cooling. The hot wires were exposed to the free stream flow at both measurement heights. Outputs were both measured directly (for calibration purposes) and bandpass filtered in order limit measured windspeed fluctuations to the inertial subrange part of the energy spectrum. The filtered signal was "root mean squared" and then measured. This filtered energy was the fundamental quantity used in the calculation of wind stress (described in a later section). The bounds of the bandpass were independently selected and verified with the aid of a spectrum analyzer. (Power spectral density was required to follow a $-5/3$ slope" through the range of the bandpass.) Spectra were plotted on a regular basis (~every hour) and are available upon request.

Data Logging

The data acquisition system (DAS) is an HP3497 and the controlling computer is an HP9836. Measurements were performed either at a "slow" rate (every 30 seconds) or a "fast" rate (every 1 second), depending on the instrument and measurement objectives. Digitized quantities were temporarily stored in arrays until the end of a measurement cycle (every 10 minutes). At that time a foreground program was entered where calibrations were applied, mean and/or standard deviations were calculated, higher level calculations were made, and data were stored. DAS operations continued during this processing as a background task. This allowed advanced quantities to be derived in situ while maintaining a continuous time series of measurements.

Data acquisition continued around the clock throughout the R/V Acania's participation in SCCAMP, except during a few short periods when the ship was in port to exchange personnel. While the system was automatic, a meteorologist was constantly on duty to monitor the system, coordinate course changes, and to perform hourly observations.

Data Content

Table 2 lists all stored values while table 3 gives format and tape specifications. A short description of quantities in order of appearance (in table 2) follows below.

Dates are in Julian format. PDT times were recorded at the end of a measurement period, which ended as close as possible to a 10 minute hourly division (e.g. 1800, 1810, etc).

While the ship's navigation equipment operated flawlessly during the entire cruise, a LORAN-C system interfaced to EPG's DAS failed. This required navigational information to be manually derived from the crew and scientific logs, and coded into the SCCCAMP data set. Table 4 lists the two codes used to describe navigational information. More discussion follows in the "Field Operations" section.

Mean values of the pendulum/accelerometer device's output are not properly offset. Because of difficulties in defining an "at rest" state for the ship and accelerator drift, all bias constants for these output were set to zero. Any calculations using these quantities force the mean to zero and use the residual bias for all instantaneous values. (More discussion will follow.)

Standard vane directions and bivane azimuth directions are all presented as relative wind direction from the bow (i.e. 0 degrees mean wind is coming from dead ahead). As previously mentioned, if the relative wind direction was greater than 120 or less than 240, the entire record was not recorded. True wind directions (and speeds) were calculated from the sum of the relative vector and the ship's heading vector.

Two basic methods were used to calculate wind stress and subsequent quantities that rely on wind stress (i.e. heat flux). The "turbulent" method refers to the turbulent dissipation technique which utilizes hot wire anemometry while the "bulk" method uses drag coefficient parameterizations which rely on values of the mean wind speed.

The turbulent dissipation technique makes the basic assumption that mechanical and buoyant production of turbulence balances turbulent dissipation of energy in the surface layer. The steady state energy equation then becomes

$$\frac{1}{2} \frac{\partial q^2}{\partial t} = 0 = - \overline{u'w'} \frac{\partial V}{\partial z} - \epsilon + \frac{g}{T} \overline{T'w'} \quad (1)$$

Applying surface layer similarity gives

$$\epsilon = (u_*^3 / k_v z) \phi \epsilon(z/L) \quad (2)$$

where

$$u_* = \frac{U k_v}{1n(z/z_{om}) - \phi_m(z/L)} \quad (3)$$

and $\phi \epsilon(z/L)$ accounts for the buoyancy term. For unstable conditions ($z/L < 0$), $\phi \epsilon$ is set equal to $\phi_m - z/L$, as a non-dimensionalized equation 1 would predict. On the stable side, $\phi \epsilon$ has been determined by empirical fits using equation 2. This procedure implies that if dissipation can be measured, wind stress can be calculated. Fortunately, Kolmogorov discovered a

portion of the turbulent energy spectrum which only depends of dissipation and has the convenient form

$$S_u(k) = K \epsilon^{2/3} k^{-5/3} \quad (4)$$

where K is a non-dimensional constant.

Selecting the appropriate spectral range from the shape of measured spectra, we integrate eq. 4 and obtain the dissipation rate.

Imbedded within this procedure is the assumption that bandpassed turbulent energy is either measured directly using an absolute calibration of the hot wire, or the appropriate relationship between measured electrical energy and wind energy can be derived. Absolute calibrations of hot wires are very system dependent and susceptible to drift. Because of these difficulties, a "dynamic" calibration was performed in situ which relates the total wire energy to the wind speed energy as measured by the bivane. The relationship can be easily derived by assuming the convective heat loss from a cylinder with a constant temperature (resistance) can be approximated by

$$V^2 = V_0^2 + B U_{rel}^{1/2} \quad (5a)$$

where B and V_0 are constants and V^2 is the electrical power necessary to balance forced convection. Differentiating eq. 5 and solving for B gives

$$B = 4 V U_{rel}^{1/2} \frac{dV}{dU_{rel}} \quad (5b)$$

EPG estimates dV/dU_{rel} as the ratio of the total RMS voltage to the total RMS windspeed as measured by the bivane. This calibration is performed for each measurement period and the

result is referred to as "B dynamic" in the data set. For more information on hot wire techniques, see Schacher et al. (1982).

Having measured the dissipation rate, u^* and L can be iteratively derived from eq. 2 and the following equations:

$$L = \frac{\partial u_*^2}{k_v g T_{*v}} \quad (6)$$

$$T_{*v} = T_* + 6.1 \times 10^{-4} T q_* \quad (7)$$

$$T_* = \frac{(\theta - \theta_s) k_v}{\ln(z/z_{0t}) - \phi_t(z/L)} \quad (8)$$

$$q_* = \frac{(q - q_s) k_v}{\ln(z/z_{0q}) - \phi_q(z/L)} \quad (9)$$

Temperature and humidity roughness lengths were assumed constant. The dimensionless temperature and humidity stability correction functions were assumed identical, and taken from Large and Pond (1981). The momentum roughness length was obtained from equation 3 with dimensionless wind shear stability correction functions also from Large and Pond (1981). The dissipation stability functions of equation 2 were from McBean and Elliott (1975) for unstable conditions and Wyngaard and Cote (1971) for stable stratifications.

The "bulk" method of determining wind stress relies on parameterization of the drag coefficient, or the momentum exchange coefficient, defined as

$$C_d = \left(\frac{u_*}{u}\right)^2 \quad (10)$$

EPG uses Kondo's (1975) parameterization of the neutral drag coefficient which was assumed to be a function of wind speed only (see table 5). The neutral drag coefficient can be related to the stability-corrected drag coefficient of eq. 10 as follows:

$$C_d = C_{dn} [1 - \phi_m(z/L) C_{dn}^{1/2} / \alpha k_v]^2 . \quad (11)$$

Analogous equations define heat and moisture exchange. α is a constant with value 1.0 for momentum and 1.35 for heat and moisture. Once wind stress is calculated from eq. 10, the remaining bulk quantities of table 2 are derived from eqs. 6-9.

Unlike the turbulent method, the drag coefficient (wind stress term) and the Obukhov length (the stability term) are not iteratively solved in the bulk method. Instead, the Obukhov length is calculated from the "first guess" of the friction velocity. The stability corrected drag coefficient is then computed from equation 11.

The table 5 parameterization applies to a 10 m height. The 5 m drag coefficient will therefore be slightly underestimated while the 20 m drag will be overestimated. These inaccuracies, however, are small when considering the simplicity of the Kondo (1975) approach which assumes open ocean conditions and very long averaging times. The bulk calculations were installed only as a benchmark for the turbulent calculations, and as a backup to the turbulent values when they are unreliable.

Sensible and latent heat flux were calculated only for the turbulent quantity group. The equations are

$$H_S = \rho c_p u^* T^* \quad (12)$$

and

$$H_L = \rho L_v u^* q^* \quad (13)$$

where ρ is calculated from the ideal gas law.

The two most frequently used measures of turbulence for air pollution dispersion estimates are horizontal and vertical wind direction standard deviations. Values of these quantities as measured by the bivane anemometers are given in the SCCAMP data set (word nos. 35, 37, 39, 41, tab. 2).

These values were vectorized into ship coordinates and are also given (word nos. 110-115), where u is along the fore-aft axis. As previously mentioned, these turbulent quantities have been corrected for ship motions and a description of those procedures is given in Appendix A. Those methods and results should only be considered developmental and users of this data set are advised to read the "Quality" section before using the Appendix A derived quantities.

III. SAMPLING PATTERNS/FIELD OPERATIONS

The R/V Acania left Monterey on 04 Sep and returned 27 Sep 1985. After loading equipment at Port Santa Barbara, field operations were initiated and modified based on radio communications from SCCAMP headquarters.

Operations consisted of three primary tasks:

- tracer gas releases
- Intensive Area sampling
- bouy/platform intercomparisons

The Acania served as a platform for release of tracer gas on 3 separate occasions. Table 6 summarizes the release information. In all cases, gas was continuously released from a height of 10 m for a period of approximately 4 hours. All releases took place at a position close to Pt. Arguello (see table 4 for exact position). Since it was crucial to be as close as possible to the position, the ship was adrift for a large portion of those 4 hours. At least 1 hour of aerometric data was collected at the site both before and after each release.

The majority of the period from 12 Sep to 25 Sep was spent in the Intensive Sampling Region. This region (shown in figure 3) was located in the northwest portion of the Santa Barbara Channel. The Acania's task was to monitor aerometric conditions at six positions relatively close to shore; an area not "seen" by SCCAMP's doppler radar study. For more information, see Dabberdt et al. (1985).

The basic sampling pattern used was to steam to a point roughly 1 n mi to leeward of a given position and slowly proceed upwind to a spot 1 n mi to windward of the position. After consulting the scientist on duty, the skipper would then steam to the next position and repeat the procedure. A complete cycle through all six positions would take roughly 10-12 hours. During the first intensive period attempts were made to shorten the upwind tacks, and perform several passes by each location before going to the next position. This technique, however, was too time consuming, and therefore abandoned in favor of the single tack procedure.

Meteorological conditions were not favorable for tracer releases during the period 04 Sep - 12 Sep and shorter periods thereafter. These "non-intensive" periods offered an opportunity for numerous intercomparisons with various meteorological stations throughout the Santa Barbara Channel area (see table 4). The operations of the Acania were similar to the intensive area operations, except that upwind tacks were started and finished within 1/2 n mi of the selected stations since close proximity was desirable for the intercomparisons. Several such upwind tacks were performed at each site. Return trips to the downwind positions were under full power, to minimize records with winds from astern. The added maneuvers required some additional coordination with the duty scientist to minimize records containing major course changes. All course changes and heading were logged.

IV. QUALITY ASSURANCE/DATA PROCESSING AND EDITING

High quality data were assured primarily by 24 hour/day monitoring of all systems by the scientist on duty. Every 10 minutes a data record was output to the computer screen for examination, and every third record was output to a printer as a hardcopy record (see figure 4 for an example). Any instrument failure was logged, and repairs were made as quickly as possible. In addition, hourly observations of seas, clouds, winds, temperature, and relative humidity were logged as an additional check and backup. Table 7 supplies the complete set of hourlies.

After the experiment, data were again screened, but this time the procedures were computerized. Values were checked for reasonable ranges. Known faulty data as recorded by the watch scientist were edited. (All edited data were assigned the value $-9.E+99$.)

Users of these data, particularly the turbulence data, should pay close attention to the condition code when selecting records. Highest quality data coincide with a code 1 (slow ahead into the wind). Code 2 or 5 can be used if relative wind direction is checked and shown to be close to the forward direction. Code 4 data (major course change) will be low quality for turbulent quantities. Code 3 (adrift) data usually results in perpendicular relative winds, and therefore caution is advised. Mean quantities will be unaffected by the condition code because of averaging.

While code screening will eliminate flow distortion and non-stationarity problems, other problems occasionally contaminate hot wire results. Radio transmissions, low windspeeds, and sea spray or fog all adversely affect results. EPG-NPS has developed

techniques for handling these problems, but these procedures are time consuming and beyond the scope of this project.

Mean bivariate elevations may be as large as 5-10 degrees from horizontal due to difficulties in vertical alignment, and therefore should not be used directly. The standard deviations of the elevations are not affected by this problem.

As previously mentioned, the mean accelerometer/pendulum "raw" quantities also suffer from alignment problems, and these values should not be used directly. As with the elevation angles, standard deviations are unaffected.

As noted earlier, the pendulum/accelerometer data and calculations were not mandated in EPG's SCCAMP contract, but are nonetheless supplied in the data set. EPG cannot guarantee the quality of these data for a number of reasons:

- a) The potentiometers had several "flat" spots, reducing accuracy.
- b) Calibrations were only performed once; before the experiment.
- c) The vertical accelerometer channel had electrical problems. (An in-depth analysis of this problem is needed.)
- d) The equations of Appendix A have not been fully proven, and may be incomplete.

Given the above disclaimer, EPG suggests using these data only as a check for accepting or rejecting the measured bivariate turbulence quantities. From the raw pendulum/accelerometer signals and Appendix A calculations, the user can get an estimate of the magnitude of ship motion contamination, and then screen the bivariate data appropriately.

V. Data Presentation

The Santa Barbara Channel area has a very diverse climate. A wide range of stabilities and wind conditions were encountered during the R/V Acania's aerometric survey. A typical scenario for SCCAMP is described below. A strong northerly flow at Pt. Arguello, often veiled under a curtain of fog, would angle off-shore as the coastline curved eastward. Flow inside the Channel primarily was moderate westerly daytime breezes with abrupt changes to northeasterly evening flow. The reversal transition zone would originate near shore and progress out into the channel during the evening. While this offshore flow was primarily low velocity, occasionally strong, warm gusts would be experienced near dusk and close to shore at the foot of the Santa Ynez Mountains.

Figures 5-7 show a record of wind speeds/directions and relative humidities for the entire cruise (without regard to ship position). Note the primarily light winds during the first week. These conditions were atypical, and not conducive to oxidant (air pollution) episodes. The remainder of the cruise was primarily under westerly flow with sharp reversals at night, as described above.

Figures 8-10 show a similar plot of friction velocity obtained from the hot wires at two levels and bulk stress values at one height. Under most atmospheric conditions, this quantity can be considered constant with height. In general, this characteristic appears to be true when the two hot wire levels are compared. The lower level does record high values more frequently than the high level, but this would be the expected result when the "constant flux layer" assumption dissolves under

stable conditions. Also, the upper and lower friction velocity values track together rather nicely. Since the two systems were independent, this characteristic supports the legitimacy of these data.

The bulk friction velocities do not closely follow the hot wire data. This can be expected when considering the simplicity of the "wind speed only" parameterization used and the complex nature of the Santa Barbara Channel flow. More analysis is warranted.

Figure 11-13 plot sensible and latent heat flux as calculated from the turbulent (hot wire) method. Also plotted is non-dimensional stability. Conditions varied from neutral to unstable due to the warm sea surface temperatures in the Santa Barbara Channel. The only stable surface layers were measured when the ship left the Channel (i.e. tracer releases at Pt. Arguello). Incidentally, the sea surface temperature front at the north end of the Channel was very pronounced at times (3-4°C).

In general, sensible heat flux values were quite low for the entire cruise owing to small air-sea temperature differences. A feature not easily seen on these figures (because of the coarse time resolution) was a reversal in the temperature gradient, and therefore sensible heat flux, during windy, foggy conditions. For extended periods of time the 5 m level would be lower than either the sea temperature or the 20 m temperature. This phenomenon was documented on several occasions, and cannot be attributed to instrument error. During these cases, the fog layer was quite

shallow and often sea spray was present due to the high winds. The physical mechanism producing this phenomenon is unknown.

Latent heat flux values were wide ranging. Large values can be attributed to the low humidity levels achieved during offshore flow. Low humidity levels were not exclusively correlated with offshore flow, however, and may be the result of a complex recirculation of continental air.

ACKNOWLEDGEMENTS

The authors appreciated the helpful, friendly crew of the RV Acania on her final voyage for NPS. Thanks also are extended to Steve Blankschein and Dick Littlefield for their technical and manual assistance. We thank the NPS Physics Department secretaries (Lulu, Patty, and Sue) for typing this report.

LIST OF TABLES

- Table 1. RV Acania surface layer aerometric instrumentation.
- Table 2. SCCCAMP EPG-NPS 10 minute data file content from the RV Acania. See Table 3 for FORMAT specifications. See text for additional information on quantities listed.
- Table 3. SCCCAMP EPG-NPS tape specifications and 10 minute data file FORMAT.
- Table 4. Position and condition code definitions for the RV Acania during SCCCAMP.
- Table 5. Kondo's (1975) parameterization of the neutral drag coefficient. This scheme was used for the "bulk" method of obtaining wind stress.
- Table 6. Tracer release times and quantities. All releases were continuous and from a height of 10 m.
- Table 7. Complete hourly observation record.

TABLE 1.

<u>Location</u>	<u>Quantity Measured</u>	<u>Instrument Used</u>	<u>Resolution</u>	<u>Response</u>
5, 20 m towers	Mean wind speed/ direction	cup anemometer ₁ standard wind vane ₂ bivane anemometer ₃	speed: 0.1 m/s direction: deg	0.2 m/s _a
5, 20 m towers	turbulent wind speed and direction (ver- tical & horizontal)	bivane anemometer	speed: 0.01 m/s direction: 0.1 deg	1.0 m _b 1.0 m _c
5, 20 m towers	high frequency wind speed	hot wire anemometer ₄	0.001 m/s	200 Hz
5, 20 m towers	mean dew point temperature	cooled mirror ₅	0.01°C	0.1 Hz
5, 20 m towers and sea surface	mean temperature	platinum resistance thermometer ₆	0.01°C	0.1 Hz
ship center of gravity	pitch, roll, rate pitch, rate roll, three-dimensional accelerations	pendulum/accelerometer ₇	position: 1 deg rate: 1 deg/s	2-5 Hz
--	ship speed	acoustic doppler velocity profiler ₈	0.1 m/s	0.1 Hz
--	ship heading	gyro ₇	0.1 deg	2 Hz

- a threshold
- b distance constant
- c delay distance

- 1 Meteorology Research Inc., Model 1022 S
- 2 Meteorology Research Inc., Model 1022 D
- 3 R. M. Young Co. Model 21003
- 4 TSI Inc. Model 1210-60
- 5 General Eastern Inc. Model 1200
- 6 Rosemount Inc. Model 0078SOLN1200
- 7 custom made
- 8 Ametek Straza Inc. Model 4015

TABLE 2.

Subscripts

- 1: Processing level. Raw level is only calibrated, averaged and/or varianced. High level quantities are derived from raw quantities.
- 2: slow sample rate is every 30 seconds, fast sample rate is every 1 second
- 3: see table 3
- 4: mean
- 5: standard deviation
- 6: positive pitch is bow up
- 7: positive roll is port side up
- 8: speed of the ship's center of gravity due to external accelerations where
X is positive in the forward direction
Y is positive to the right
Z is positive up and aligned with the earth's gravitational vector
- 9: all "1" quantities refer to the lower instrument array, "2" quantities refer to the upper array
- 10: positive elevation is an updraft
- 11: see text for hot wire anemometry description
- 12: t refers to the "turbulence" method (see text)
- 13: b refers to the "bulk" method (see text)
- 14: bivane is used when operating, otherwise cups/vane is used
- 15: velocity due to rotational velocity of the sensor about the ship center of gravity
- 16: velocity due to external accelerations
- 17: "quick method" (see text)

<u>Quantity</u>	<u>Units</u>	<u>Level₁</u>	<u>Sample Rate₂</u>	<u>Word No</u>
date	Julian day	--	--	1
record end time	PDT hr/min/sec	--	--	2
position code ₃	--	--	--	3
condition code ₃	--	--	--	4
ship speed	m/s	raw	slow	5
ship heading	deg true	raw	slow	6
pitch ₆ m ₄	deg	raw	fast	7
pitch sd ₅	deg	raw	fast	8
roll ₇ m	deg	raw	fast	9
roll sd	deg	raw	fast	10
pitch rate m	deg/sec	raw	fast	11
pitch rate sd	deg/sec	raw	fast	12
roll rate m	deg/sec	raw	fast	13
roll rate sd	deg/sec	raw	fast	14
heave ₈ X m	m/s	raw	fast	15
heave X sd	m/s	raw	fast	16
heave Y m	m/s	raw	fast	17
heave Y sd	m/s	raw	fast	18
heave Z m	m/s	raw	fast	19
heave Z sd	m/s	raw	fast	20
sea surface temp	celsius	raw	slow	21
air ₉ temp 1	celsius	raw	slow	22
air temp 2	celsius	raw	slow	23
dew pt temp 1	celsius	raw	slow	24
dew pt temp 2	celsius	raw	slow	25
cup anemometer 1	m/s	raw	slow	26
cup anemometer 2	m/s	raw	slow	27
standard vane 1	deg	raw	slow	28
standard vane 2	deg	raw	slow	29
bivane speed 1 m	m/s	raw	fast	30
bivane speed 1 sd	m/s	raw	fast	31
bivane speed 2 m	m/s	raw	fast	32
bivane speed 2 sd	m/s	raw	fast	33
bivane ₁₀ elevation 1 m	deg	raw	fast	34
bivane elevation 1 sd	deg	raw	fast	35
bivane elevation 2 m	deg	raw	fast	36
bivane elevation 2 sd	deg	raw	fast	37
bivane azimuth 1 m	deg	raw	fast	38
bivane azimuth 1 sd	deg	raw	fast	39
bivane azimuth 2 m	deg	raw	fast	40
bivane azimuth 2 sd	deg	raw	fast	41
hot wire anemom 1 m	volt	raw	fast	42
hot wire anemom 1 sd	volt	raw	fast	43
hot wire anemom 2 m	volt	raw	fast	44
hot wire anemom 2 sd	volt	raw	fast	45
hot wire RMSer 1	volt	raw	fast	46
hot wire RMSer 2	volt	raw	fast	47
no. fast samples	--	--	--	48
no. slow samples	--	--	--	49
hot wire low freq cutoff ₁₁	hz	--	--	50
hot wire high freq cutoff	hz	--	--	51

RMSeR gain ₁₁	--	--	--	52
wind sensor height 1	m	--	--	53
wind sensor height 2	m	--	--	54
temp, dew sensor ht 1	m	--	--	55
temp, dew sensor ht 2	m	--	--	56
Obukhov length 1t ₁₂	m	high	--	57
Obukhov length 2t	m	high	--	58
Obukhov length 1b ₁₃	m	high	--	59
Obukhov length 2b	m	high	--	60
momentum roughness 1t	m	high	--	61
momentum roughness 2t	m	high	--	62
momentum roughness 1b	m	high	--	63
momentum roughness 2b	m	high	--	64
temp, hum roughness 1t	m	high	--	65
temp, hum roughness 2t	m	high	--	66
temp, hum roughness 1b	m	high	--	67
temp, hum roughness 2b	m	high	--	68
mom exch coeff 1t	--	high	--	69
mom exch coeff 2t	--	high	--	70
mom exch coeff 1b	--	high	--	71
mom exch coeff 2b	--	high	--	72
temp exch coeff 1t	--	high	--	73
temp exch coeff 2t	--	high	--	74
temp exch coeff 1b	--	high	--	75
temp exch coeff 2b	--	high	--	76
hum exch coeff 1t	--	high	--	77
hum exch coeff 2t	--	high	--	78
hum exch coeff 1b	--	high	--	79
hum exch coeff 2b	--	high	--	80
u* 1t	m/s	high	--	81
u* 2t	m/s	high	--	82
u* 1b	m/s	high	--	83
u* 2b	m/s	high	--	84
θ* 1t	Celsius	high	--	85
θ* 2t	Celsius	high	--	86
θ* 1b	Celsius	high	--	87
θ* 2b	Celsius	high	--	88
q* 1t	g/kg	high	--	89
q* 2t	g/kg	high	--	90
q* 1b	g/kg	high	--	91
q* 2b	g/kg	high	--	92
epsilon 1t	m ² /s ³	high	--	93
epsilon 2t	m ² /s ³	high	--	94
B dynamic ₁₁ 1t	volt ² /(m/s) ^{1/2}	high	--	95
B dynamic 2t	volt ² /(m/s) ^{1/2}	high	--	96
sensible heat flux 1t	watt/m ²	high	--	97
sensible heat flux 2t	watt/m ²	high	--	98
latent heat flux 1t	watt/m ²	high	--	99
latent heat flux 2t	watt/m ²	high	--	100
atmospheric pressure	mb	raw	slow	101
relative humidity 1	%	high	--	102
relative humidity 2	%	high	--	103
specific humidity 1	g/kg	high	--	104
specific humidity 2	g/kg	high	--	105

true wind speed	14 1	m/s	high	--	106
true wind speed	2	m/s	high	--	107
true wind direction	14 1	deg	high	--	108
true wind direction	2	deg	high	--	109
s5 u measured	1	m/s	high	fast	110
s u measured	2	m/s	high	fast	111
s v measured	1	m/s	high	fast	112
s v measured	2	m/s	high	fast	113
s w measured	1	m/s	high	fast	114
s w measured	2	m/s	high	fast	115
s u rotation	15 1	m/s	high	fast	116
s u rotation	2	m/s	high	fast	117
s v rotation	1	m/s	high	fast	118
s v rotation	2	m/s	high	fast	119
s w rotation	1	m/s	high	fast	120
s w rotation	2	m/s	high	fast	121
s u acceleration		m/s	high	fast	122
s v acceleration		m/s	high	fast	123
s w acceleration		m/s	high	fast	124
s u true	1	m/s	high	fast	125
s u true	2	m/s	high	fast	126
s v true	1	m/s	high	fast	127
s v true	2	m/s	high	fast	128
s w true	1	m/s	high	fast	129
s w true	2	m/s	high	fast	130
s elevation rotation	1	deg	high	fast	131
s elevation rotation	2	deg	high	fast	132
s speed quick	17 1	m/s	high	--	133
s speed quick	2	m/s	high	--	134
s elevation quick	1	deg	high	--	135
s elevation quick	2	deg	high	--	136
s azimuth quick	1	deg	high	--	137
s azimuth quick	2	deg	high	--	138
s speed true	1	m/s	high	fast	139
s speed true	2	m/s	high	fast	140
s elevation true	1	deg	high	fast	141
s elevation true	2	deg	high	fast	142
s azimuth true	1	deg	high	fast	143
s azimuth true	2	deg	high	fast	144

TABLE 3.

Tape Specifications

Labels: None
Density: 1600 CPI
Characters: ASCII
Record Size: 132 bytes*
Block size: 5280 bytes

* Requested by SCCAMP archivist. Actual logical record span records.

Logical Record Map

<u>Word Nos.</u>	<u>Record Nos.**</u>	<u>FORTTRAN format</u>
1-11	1	I5,X,I6,X,F5.2,X,I2,X,7(E13.6,X),12X
12-47	2-5	4(9(E13.6,X),6X,/)
48-62	6	5(I3,X),4(F4.1,X),6(E13.6,X),8X
63-143	7-15	9(9(E13.6,X),6X,/)
144	16	E13.6,119X

** Since blocking factor = 40, only one logical record is contained in each block to avoid staggered records.

IMPORTANT: All edited data is assigned the value -9.E+99. Only exponentially formatted data is editable.

TABLE 4.

Position codes are normally whole numbers, implying that the ship was within 1 n mi of the position. When the position code contains non-zero digits to the right of the decimal, the ship is in transit from the integer position to the decimal position (e.g. 18.09 means moving from position 18 to position 9). Condition codes are always whole numbers.

<u>POSITION CODE</u>	<u>POSITION</u>	<u>LONGITUDE</u>	<u>LATITUDE</u>
1	A	119 56.00	34 23.00
2	B	120 01.50	34 21.00
3	C	120 07.50	34 25.50
4	D	120 15.00	34 26.00
5	E	120 19.00	34 22.50
6	F	120 24.5	34 24.50
7	Pt. Sal Bouy	120 54.90	34 55.00
8	Pt. Conception Bouy	120 40.00	34 14.90
9	Santa Monica Bouy	119 00.00	33 36.00
10	Mid-Channel Bouy	120 06.40	34 14.80
11	Mugu Canyon Bouy	119 08.00	34 59.40
12	Platform Hondo	120 07.00	34 23.40
13	Platform C	119 37.70	34 19.90
14	Platform Gina	119 16.50	34 07.00
15	Tracer Release Site	120 43.40	34 30.70
16	Port Santa Barbara	119 41.00	34 24.70
17	Port Hueneme	119 12.70	34 08.80
18	Ellwood Pier	119 55.72	34 25.33
19	Frys Hbr.	119 40.44	34 04.77
20	West Pt-Santa Cruz Is.	119 54.55	34 06.07
21	San Miguel Passage	120 13.45	34 03.84
22	no name	120 39.00	34 16.30
23	no name	120 44.50	34 23.20

<u>CONDITION CODE</u>	<u>CONDITION</u>
1	Steaming slow ahead upwind
2	Steaming full ahead downwind
3	adrift
4	major course change during the record
5	steaming between positions

TABLE 5.

<u>wind speed range</u>	<u>neutral drag coefficient x 10³*</u>
0.3-2.2 m/s	1.08 U ^{-1.5}
2.2-5.0 m/s	0.77 + 0.086 U
5.0-8.0 m/s	0.87 + 0.067 U
8.0-25.0 m/s	1.2 + 0.025 U

* drag coefficients and wind speed defined at a 10 m height from "open" ocean conditions. Reference is Kondo (1975).

TABLE 6.

Tracer Releases

<u>Date</u>	<u>Time (PDT)</u>	<u>Approximate Amount PP3*</u>
9/13/85	0410-0800	7-8 liters
9/20/85	0425-0805	19 liters**
9/24/85	0400-0800	19 liters

*Perfluoradimethylcyclohexane; for exact information contact
SCCCAMP archivist.

**This release troubled by an inconsistent flow rate. Consult
authors for more information.

TABLE 7

-KEY-

D = date of observation

HR = time of observation

CH = cloud height
(L = low, M = medium, H = high)

CT = cloud type and coverage
(ST = stratus, CI = cirrus, CU = cumulus)
(digit represents coverage in eighths)

S = swell height and direction

P = 5m atmospheric pressure
(pressure transducer)

W = 20m wind speed and direction
(ships cups and vane)

T = 5m air temperature
(mercury thermometer)

RH = 5m relative humidity
(psychrometer)

D	HR(PDT)	CH	CT	S(ft,dir)	P(mb)	W(m/s,deg)	T(F)	RH%
9/3	10	L	ST8	5,NW	1014.5	3.0,225	56	80
	11	L	ST8	5,NW	1014.8	3.5,140	56	80
	12	L	ST8	5,NW	1015.2	3.0,140	57	80
	13	L	ST8	5,NW	1015.2	3.0,5	57	80
	14	L	ST8	4,NW	1015.2	2.0,5	57	80
	15	L	ST8	3-4,NW	1014.6	5.0,5	58	94
	16	L	ST8	3-4,NW	1014.5	2.2,258	58	94
	17	L	ST8	2-3,NW	1014.5	1.9,247	60	95
	18	L	ST8	2-3,NW	1014.2	2.1,250	60	93
	19	L	ST8	1-2,NW	1014.2	calm	58	94
	20	L	ST8	1-2,NW	1014.5	1.4,285	60	99
	21	L	ST8	1-2,NW	1015.1	1.8,284	60	99
	22	L	ST8	1-2,NW	1015.3	1.8,280	60	96

no reports all evening

9/4	7	L	ST4	4,NW	1016.2	3.9,291	62	76
	8	L	ST6	3-4,NW	1016.6	1.9,113	64	68
	9	L	ST8	2,NW	1016.6	2.3,157	64	68
	10	L	ST8	1-2,NW	1017.6	3.2,229	64	68
	11	L	ST8	1-2,NW	1018.1	1.8,212	66	64
	12	L	ST8	1-2,NW	1017.6	1.9,199	68	64
	13	L	ST8	1-2,NW	1017.3	2.8,241	68	62
	14	L	ST8	1-2,NW	1017.3	3.5,238	67	63
	15	L	ST4	1-2,NW	1017.3	3.5,180	68	63
	16	L,H	ST4,CI4	1-2,NW	1016.8	3.0,180	68	63
	17	L,H	ST4,CI4	1-2,NW	1015.7	3.2,241	68	64
	18	L,M	ST4,CU4	1-2,NW	1015.5	3.9,273	65	72
	19	L,M	ST4,CU4	1-2,NW	1015.7	4.3,285	65	76
	20	L	ST8	NR	1016.3	3.8,292	64	80
	21	L	ST8	1-2,W	1016.3	2.7,312	64	80
	22	L	ST8	1-2,W	1016.8	1.6,311	64	76
	23	L	ST8	1-2,W	1016.7	NR	64	73

9/5	00	L	ST8	1-2,W	1016.9	NR	63	80
	01	NR	NR	1-2,W	1016.6	2.2,257	63	78
	02	NR	NR	1-2,W	1016.5	3.5,263	64	78
	03	NR	NR	1-2,W	1016.3	2.8,253	64	72
	04	L	ST8	1-2,W	1016.2	2.5,249	64	70
	05	L	ST8	1-2,W	1016.2	1.9,282	64	70
	06	L	CU8	1-2,W	1016.4	2.0,259	64	73
	07	L	CU8	2-3,W	1016.7	1.8,283	64	71
	08	L,M	ST4,CU4	2-3,W	1017.3	1.2,305	65	65
	09	L,M	ST4,CU4	2-3,W	1017.3	1.8,235	65	70
	10	L,M	ST4,CU4	2,W	1017.1	1.4,281	65	67
	11	L,M	ST4,CU4	2,W	1016.8	2.4,238	68	58
	12	L,M	ST4,CU4	2,W	1016.7	0.9,245	72	54
	14	M	ST4	1-2,W	1017.2	2.5,169	70	59
	15	M	ST4	1-2,S	1016.6	3.1,177	71	60
	16	M	ST4	2,SW	1016.2	2.7,184	72	58
	17	M	ST2	2,SW	1016.2	2.3,212	70	56
	18	M,H	ST4,CI4	2,SW	1015.7	2.0,251	70	59
	19	M,H	ST4,CI4	1,SW	1015.8	0.9,189	68	63
	20	M,H	ST4,CI4	1,SW	1015.8	0.9,206	66	66

D	HR(PDT)	CH	CT	S(ft,dir)	P(mb)	W(m/s,deg)	T(F)	RH%
9/5	21	NR	NR	calm	1015.9	0.6,200	66	67
	22	NR	NR	calm	1016.0	0.6,235	66	68
	23	NR	NR	calm	1015.9	NR	65	66
9/6	00		CL	calm	1015.7	1.4,80	65	75
	01		CL	1,W	1016.0	2.0,90	64	76
	02		CL	1-2,W	1015.6	2.0,80	63	80
	03		CL	2,W	1015.3	2.0,60	63	80
	04		CL	1-2,W	1015.1	2.3,56	64	80
	05		CL	1-2,W	1014.3	2.5,58	63	82
	06		CL	1-2,W	1014.4	2.3,48	62	82
	07	M	ST8	1-2,W	1016.2	2.7,61	62	80
	08	M	ST8	1-2,W	1015.5	2.0,68	63	75
	09	M	ST8	1-2,W	1015.9	2.6,67	63	74
	10	M	ST8	NR	1016.3	NR	65	85
	11	M	ST8	NR	NR	NR	NR	NR
	12	M	ST8	NR	1016.5	NR	67	67
	13	M	ST8	1-2,NW	1016.5	1.2,201	66	75
	14	M	CU8	calm	1016.1	0.5,86	68	70
	15	M	CU8	calm	1016.5	calm	70	68
	16	M	CU8	calm	1016.5	calm	74	60
	17	M	ST8	calm	1016.5	1.5,243	72	60
	18	M	ST8	calm	1016.4	1.1,263	70	65
	19	M	ST8	calm	1016.5	calm	70	65
	20		CL	calm	1017.2	1.6,287	67	73
	21		CL	calm	1016.8	2.0,316	67	73
	22		CL	calm	1017.2	2.7,271	66	84
23		CL	calm	1017.3	3.1,280	65	85	
9/7	00		CL	calm	1017.6	1.6,318	65	80
	01		CL	calm	1017.6	2.4,300	65	85
	02	M	ST4	calm	1017.3	1.6,47	65	80
	03		CL	calm	1017.3	0.5,24	64	80
	04		CL	calm	1017.3	1.8,63	64	82
	05		CL	calm	1017.6	1.8,62	64	77
	06	L	ST2	calm	1017.9	2.0,111	64	79
	07	L	ST3	calm	1018.4	3.0,95	64	85
	08	L	ST7	1,W	1019.6	2.3,96	64	86
	10	L	CU8,R	1,W	1020.2	2.3,296	63	94
	11	L	CU8	2,W	1020.8	2.4,117	66	79
	12	L	CU8	2,W	1020.5	3.2,159	68	64
	13	L	CU8	2,W	1020.2	4.4,175	68	66
	14	L	CU8	2,W	1020.1	2.4,189	68	75
	15	L	CU4,CI4	2-3,W	1020.4	2.5,195	68	75
	16	L,H	CU8	2,NW	1020.0	1.9,246	68	70
	17	L	CU8	2,NW	1019.9	1.9,226	68	70
	18	L	CU8	2,NW	1020.0	2.6,253	68	73
	19	L	CU8	2,NW	1019.8	2.1,246	63	84
	20	L	CU8	calm	1020.0	0.5,104	64	82
	21		CL	calm	1019.5	calm	63	84
	22		CL	calm	1020.0	calm	62	84
	23		CL	calm	1020.0	calm	62	84

D	HR(PDT)	CH	CT	S(ft,dir)	P(mb)	W(m/s,deg)	T(F)	RH%
9/8	00		CL	calm	1020.0	1.0,76	62	84
	01		CL	calm	1019.8	1.4,65	61	85
	02		CL	calm	1019.8	calm	61	86
	03	M	CU8,R	1-2,W	1019.6	1.4,119	60	85
	04	M	ST8	calm	1019.7	calm	60	86
	05	M	ST8	calm	1020.0	0.9,168	60	86
	06	M	ST8	calm	1020.3	1.4,157	60	87
	07	M	ST8	1-2,SW	1020.7	2.9,140	61	83
	08	M	ST8	1-2,SW	1020.7	3.3,153	62	78
	09	M	ST8	2,SW	1021.0	1.4,167	62	77
	10	M	ST8	2,SW	1021.2	2.3,185	62	81
	11	M	ST8	1-2,SW	1021.0	2.5,234	67	75
	12	L	CU8	2,SW	1020.8	1.4,192	68	71
	13	L,M	CU4, CU4	2,W	1020.1	1.7,186	66	66
	14	M	CU8	2,W	1019.7	2.2,230	70	70
	15	M	CU8	2,W	1019.8	2.4,240	70	70
	16	M	ST8	2,W	1019.2	3.0,220	69	69
	17	L	ST8	2,W	1019.0	3.0,221	66	66
	18	L	ST8	1-2,W	1018.5	1.2,256	65	65
	19	L	R	NR	1018.3	1.8,307	64	64
	20	L	R	NR	1019.3	0.6,322	63	63
	21		CL	NR	1019.3	2.4,322	62	62
	22		CL	NR	1019.1	3.6,300	63	63
	23		CL	NR	1018.9	3.2,350	63	63
24		CL	NR	1018.8	3.9,335	63	63	
9/9	01		CL	NR	1018.8	4.1,322	63	90
	02	L	CU8	NR	1018.1	2.8,274	62	89
	03	L	CU8,R	NR	1017.9	5.8,336	61	94
	04	L	CU8	NR	1018.1	6.0,330	61	85
	05	NR	NR	NR	1018.0	5.4,344	61	70
	06		CL	3-4,NW	1018.4	6.5,337	60	75
	07	M	CU8	3-4,NW	1018.8	5.5,331	60	75
	08	M	CU8	3-4,NW	1018.9	6.2,328	62	74
	09	M	CU8	4,NW	1018.8	5.2,326	62	71
	10	M	CU8	4,NW	1019.2	5.2,323	62	75
	11	L	CU8	4,NW	1019.6	5.1,321	62	72
	12	L	CU2	4,NW	1019.5	6.3,282	63	70
	13	M	ST8	4,NW	1019.5	4.5,313	66	62
	14		CL	4,NW	1018.7	6.3,305	67	62
	15		CL	4,NW	1018.1	5.3,293	70	59
	16		CL	4,NW	1017.6	6.7,289	65	66
	17		CL	4,NW	1016.7	8.0,297	64	71
	18		CL	4,NW	1015.9	10.5,299	62	76
	19		CL	6,NW	1015.7	11.1,290	62	78
	20		CL	6,NW	1016.0	7.4,304	62	74
	21		CL	6,NW	1016.6	6.4,312	62	68
	22		CL	5,NW	1016.2	6.4,307	62	73
	23		CL	5,NW	1015.7	7.0,311	61	74

D	HR(PDT)	CH	CT	S(ft,dir)	P(mb)	W(m/s,deg)	T(F)	RH%
9/10	00		CL	5,NW	1015.6	7.5,312	61	75
	01		CL	5,NW	1015.0	7.3,310	60	76
	02		CL	5,NW	1014.6	7.5,310	60	74
	03		CL	5,NW	1014.5	7.5,310	60	76
	04		CL	5,NW	1014.1	6.3,317	60	73
	05		CL	5,NW	1013.9	8.4,306	58	79
	06	M	ST4	3,NW	1014.2	2.2,312	60	72
	07	L	ST4	3-4,NW	1014.2	4.5,331	60	73
	08	L	ST4	2,SE	1014.5	0.6,124	70	74
	09	L	CU2	1-2,SE	1015.0	1.3,84	68	52
	10	L	CU2	1-2,SE	1014.5	2.7,146	70	56
	11	L	CU2	1-2,SE	1014.7	NR	72	55
	12	L	CU8	1-2,SE	1014.7	2.5,244	72	54
	13	L	CU8	1-2,SE	1014.4	4.1,258	69	58
	14	L	CU8	1-2,W	1014.5	3.1,277	69	60
	15	L	CU8	1-2,NW	1014.2	4.3,283	67	61
	16	L	CU8	2-3,NW	1013.8	6.2,292	68	65
	17	L	CU8	3-4,NW	1013.6	8.0,284	69	60
	18	L	CU8	4-5,W	1013.2	7.2,289	65	69
	19	L	CU8	5,W	1012.8	7.8,279	62	78
	20	L	CU8	5,W	1012.8	9.6,274	62	75
	21	L	CU4	6,W	1013.2	10.6,291	62	74
	22		CL	5,W	1013.4	9.4,310	62	75
	23		CL	4,W	1014.0	8.0,276	62	76
24		CL	4,W	1014.3	8.1,288	62	74	
9/11	01		CL	4,W	1014.3	6.5,283	62	74
	02		CL	3,W	1014.3	7.7,275	61	72
	03		CL	3-4,W	1014.5	6.8,281	61	73
	04		CL	4,W	1014.8	6.8,289	60	75
	05		CL	4,W	1014.8	7.5,290	61	72
	06		CL	4,W	1015.4	6.2,295	61	75
	07		CL	4,W	1016.0	5.5,313	60	77
	08	L	CU1	4,W	1016.6	4.0,329	62	72
	09	L	CU1	4,W	1017.1	1.0,20	62	71
	10		CL	3,W	1018.5	4.7,299	64	64
	11		CL	4,W	1018.5	4.2,289	65	62
	12		CL	4,W	1018.0	NR	64	56
	13		CL	4,W	1018.0	NR	69	58
	14		CL	3,W	1017.9	7.1,279	68	65
	15		CL	3,W	1017.8	6.9,270	68	66
	16		CL	3,W	1017.8	7.8,279	68	65
	17		CL	6,W	1018.1	7.9,284	64	72
	18		CL	4,W	1018.2	8.4,281	63	74
	19		CL	4-5,W	1017.8	NR	64	75
	20		CL	4,W	1018.0	7.0,284	63	73
	21		CL	4,W	1018.1	6.1,287	62	80
	22		CL	3,W	1019.1	3.0,319	62	75
	23		CL	2-3,W	1019.5	4.3,330	62	75

D	HR(PDT)	CH	CT	S(ft,dir)	P(mb)	W(m/s,deg)	T(F)	RH%
9/12	00		CL	3,W	1019.6	5.0,310	60	79
	01		CL	2-3,W	1019.5	2.5,9	62	82
	02		CL	2-3,W	1019.2	4.1,4	61	86
	03		CL	2-3,W	1018.6	3.1,355	60	82
	04		CL	2-3,W	1018.4	3.8,360	60	77
	05		CL	2-3,W	1018.0	4.6,356	60	77
	06		CL	2-3,W	1017.8	3.6,351	60	76
	07		CL	1-2,W	1017.3	4.3,344	62	65
	08		CL	1-2,W	1018.2	2.6,36	61	63
	09		CL	1-2,W	1018.2	2.7,38	64	60
	10		CL	in port	1019.4	in port	67	63
	11		CL	in port	NR	in port	NR	NR
	12		CL	in port	1018.9	in port	70	60
	13		CL	in port	1019.0	in port	71	55
	14		CL	NR	1018.7	2.5,275	74	44
	15	H	CI4	3,W	1017.5	2.8,273	70	66
	16	H	CI5	3,W	1017.5	4.0,295	70	65
	17	H	CI8	2,W	1017.2	3.0,290	70	66
	18	H	CI8	2,W	1017.1	2.3,271	69	72
	19	H	CI3	1,W	1016.7	2.3,199	62	32
	20		CL	1,W	1016.8	2.2,120	63	85
	21		CL	calm	1016.9	3.2,65	62	90
	22		CL	calm	1017.1	NR	NR	NR
23		CL	1,NW	1017.3	4.8,105	63	80	
9/13	00		CL	1,NW	1017.3	2.0,95	62	73
	01		CL	2,NW	1017.0	3.8,312	63	77
	02		CL	3-4,NW	1017.0	4.5,316	60	87
	03		CL	3-4,NW	1017.4	6.6,342	60	93
	04		CL	3-4,N	1017.9	5.8,8	60	96
	05		CL	3-4,N	1017.3	4.5,10	59	90
	06		CL	3-4,N	1018.1	5.1,9	60	88
	07		CL	3-4,N	1018.3	5.2,340	60	90
	08		CL	3-4,N	1018.7	3.6,351	60	92
	09		CL	2-3,N	1018.9	3.5,327	60	90
	10		CL	2-3,NW	1018.4	4.2,312	60	89
	11		CL	2,NW	1018.8	5.3,299	62	81
	12		CL	2,NW	1018.7	5.7,308	61	79
	13		CL	2,NW	1018.4	7.2,288	66	65
	14		CL	2,W	1018.1	6.2,276	67	68
	15		CL	2,W	1017.4	5.5,284	68	56
	16		CL	3,W	1018.0	6.0,293	68	58
	17		CL	2-3,W	1018.0	9.0,287	70	57
	18		CL	2-3,W	1017.7	8.0,298	70	60
	19		CL	2-3,W	1017.6	5.0,330	70	50
	20		CL	2-3,W	1017.5	7.6,358	68	55
	21		CL	1-2,W	1017.2	11.2,350	68	53
	22		CL	1-2,W	1018.2	10.0,338	67	55
23		CL	1-2,W	1017.6	11.6,239	71	40	

D	HR(PDT)	CH	CT	S(ft,dir)	P(mb)	W(m/s,deg)	T(F)	RH%
9/14	00		CL	1-2,W	1018.1	2.0,140	68	70
	01		CL	1-2,W	1018.3	3.3,159	62	93
	02		CL	1-2,W	1018.4	2.6,143	62	92
	03		CL	1-2,W	1018.3	2.0,253	63	91
	04		CL	1,W	1017.6	1.0,288	63	89
	05		CL	1,W	1017.9	0.3,330	63	81
	06		CL	1,W	1018.4	0.6,291	62	85
	07		CL	1,W	1018.9	1.6,73	62	70
	08		CL	1,W	1018.2	0.4,22	63	64
	09		CL	1,W	1018.6	NR	67	65
	10		CL	1-2,W	1018.6	1.6,76	72	65
	11		CL	1-2,W	1018.6	3.6,160	72	53
	12		CL	2-3,SW	1018.6	1.1,349	68	72
	13		CL	2-3,SW	1018.0	4.3,280	73	55
	14		CL	5,W	1017.2	10.7,281	72	64

in port Santa Barbara

9/15	18		CL	3,W	1013.1	1.7,275	65	75
	19		CL	5,W	1013.1	5.2,260	63	81
	20		CL	4,W	1013.5	5.4,277	62	82
	21		CL	4,W	1014.3	6.4,292	62	80
	22		CL	4,W	1013.8	4.8,301	62	75
	23		CL	4,W	1014.1	7.6,300	62	75
9/16	00		CL	3-4,W	1014.3	6.8,314	62	77
	01		CL	2,W	1014.4	5.8,316	62	77
	02		CL	2,W	1014.4	3.4,337	62	80
	03		CL	2,W	1014.4	3.5,4	62	80
	04		CL	2,W	1014.1	2.7,17	62	82
	05		CL	2-3,NW	1014.4	3.0,358	62	38
	06	L	CU8	2-3,NW	1014.9	2.4,3	62	36
	07	L	CU8	2-3,NW	1015.4	4.0,357	62	34
	08	L	CU8	2-3,NW	1015.2	4.6,355	62	32
	09	L	CU8	2-3,NW	1016.2	3.2,350	62	32
	10	L	CU8	2-3,NW	1016.6	3.0,343	64	74
	11	L	CU8	2-3,NW	1016.4	3.1,319	56	70
	12		CL	2-3,NW	1016.3	4.2,288	56	69
	13		CL	3,W	1015.9	3.8,278	65	63
	14		CL	4,W	1015.7	4.0,255	64	72
	15		CL	4,W	NR	NR	65	69
	16		CL	5,W	1014.4	4.9,268	65	72
	17		CL	5,W	1013.4	3.8,253	68	62
	18		CL	5,W	1013.5	3.0,306	68	53
	19		CL	4,W	1013.3	2.3,316	64	64
	20		CL	3-4,W	1014.0	7.3,312	63	68
	21		CL	3-4,W	1014.2	4.3,10	64	58
	22		CL	2-3,W	1014.3	4.1,15	64	57
	23		CL	3,W	1014.3	2.6,17	63	62

D	HR(PDT)	CH	CT	S(ft,dir)	P(mb)	W(m/s,deg)	T(F)	RH%
9/17	00		CL	3,W	1014.3	2.8,40	62	68
	01		CL	3,W	1014.3	6.3,304	62	79
	02		CL	3,W	1014.1	7.8,318	60	78
	03		CL	3,W	1014.1	4.2,345	60	78
	04		CL	2,W	1014.0	7.1,310	60	76
	05		CL	2,W	1013.9	6.1,307	60	78
	06	M	ST4	2,W	1014.1	7.0,306	60	80
	07	M	ST4	2,W	1014.4	6.7,292	60	76
	08	L	ST4	1-2,W	1014.8	5.9,289	60	76
	09	L	ST2	1-2,W	1015.1	6.0,280	61	76
	10	L	ST2	1-2,W	1015.5	5.0,285	62	72
	11	L	ST2	1,W	1015.4	5.0,274	64	69
	12		CL	1,W	1014.8	5.0,280	63	71
	13		CL	2,W	1014.6	7.0,350	64	65
	14		CL	2-3,W	1013.6	7.0,270	62	71
	15		CL	2-3,W	1013.0	6.6,270	62	71
	16		CL	2,W	1012.4	6.3,265	62	74
	17		CL	2-3,W	1011.7	6.4,300	62	68
	18		CI1	3,W	1012.7	8.2,277	63	70
	19		CI2	3-4,W	1011.6	5.6,275	62	74
	20		CL	2-3,W	1012.1	6.2,207	62	78
	21		CL	2-3,W	1011.8	6.6,259	62	80
	22		CL	2,W	1011.9	5.0,279	61	78
23		CL	2,W	1012.3	7.0,270	61	76	
9/18	00		CL	2,W	1012.2	3.5,275	61	73
	01		CL	1-2,W	1012.0	2.0,75	61	77
	02		CL	1-2,W	1012.0	3.1,60	60	78
	03		CL	1,W	1011.8	3.7,262	60	77
	04		CL	1,W	1011.6	1.2,155	60	76
	05		CL	1,W	1011.1	2.5,10	61	75
	06	L	ST1	1,W	1011.1	2.0,342	60	72
	07	M	CU1	1-2,W	1011.6	1.4,299	59	30
	08	M	CU1	1-2,NW	1011.0	1.0,185	60	74
	09	M	CU1	1,NW	1010.3	1.6,172	62	70
	10	M	CU1	1-2,NW	1011.2	0.7,365	70	52
	11	M	CU1	1,W	1011.6	3.5,248	65	63
	12	M	CU1	1,W	1011.5	5.0,257	64	65
	13	M	CU1	1-2,W	1011.3	6.7,255	65	63
	14	M	CU1	1-2,W	1011.3	6.4,250	66	66
	15	M	CU1	1-2,W	1011.1	5.0,250	65	70
	16	M	CU1	1-2,W	1011.5	4.1,250	64	73
	17	M	CU1	1-2,W	1011.3	4.5,246	64	74
	18	M	ST8	1,W	1011.8	4.0,255	62	80
	19	M	ST8	1-2,W	1012.6	2.6,250	61	75
	20	M	ST4	1-2,W	1013.4	2.7,232	60	81
	21	M	ST2	1-2,W	1014.1	2.1,220	60	79
	22	NR	NR	NR	1014.6	1.0,125	60	80
23	NR	NR	NR	1014.7	1.3,87	60	80	

D	HR(PDT)	CH	CT	S(ft,dir)	P(mb)	W(m/s,deg)	T(F)	RH%
9/19	00	NR	NR	NR	1015.1	1.2,175	60	80
	01	NR	NR	2-3,W	1015.3	1.7,143	60	81
	02	NR	NR	2-3,W	1015.9	1.0,40	60	85
	03	NR	NR	2-3,W	1016.1	2.0,10	59	89
	04		CL	2,W	1017.0	1.5,307	60	86
	05		CL	2,W	1017.0	2.0,321	60	85
	06		CL	2,W	1017.5	3.0,322	59	79
	07		CL	2,W	1018.7	2.7,349	60	71
	08		CL	1,W	1019.3	0.2,280	61	70
	09		CL	1,W	1019.2	calm	62	71
	10		CL	1,W	1019.8	2.6,213	63	70
	11		CL	1-2,W	1019.2	2.0,353	68	58
	12		CL	1-2,W	1019.4	4.4,235	65	69
	13		CL	1-2,W	1019.5	3.5,255	66	70
	14		CL	1-2,W	1018.1	5.0,267	69	57
	15		CL	1-2,W	1018.2	4.9,262	65	65
	16	M	ST1	3,W	1018.2	4.9,256	66	67
	17		CL	3,W	1017.5	1.2,268	70	61
	18		CL	3,W	1017.4	6.2,286	69	55
	19		CL	2-3,W	1017.9	6.7,308	67	63
	20		CL	2-3,W	1018.5	6.8,290	62	75
	21		CL	2-3,W	1019.2	5.6,286	62	76
	22		CL	2,W	1018.9	3.2,269	60	81
23		CL	2,W	1019.0	6.5,310	60	84	
9/20	00		CL	2,W	1019.3	7.2,306	60	88
	01		CL	3,W	1019.2	9.5,343	58	94
	02		CL	3,W	1019.2	9.4,344	58	93
	03	L	ST8	4,NW	1019.3	9.0,348	58	94
	04	L	ST8	4,NW	1019.2	10.5,344	57	97
	05	L	ST8	4,NW	1019.2	10.0,342	56	98
	06	L	ST8	5,NW	1019.8	10.1,345	56	99
	07	L	ST8	5,NW	1020.0	9.9,350	56	99
	08	L	ST8	6,NW	1019.9	9.5,345	56	95
	09	L	ST4	6,NW	1020.6	9.5,343	57	91
	10		CL	4,W	1020.1	9.5,317	56	91
	11		CL	3-4,W	1019.4	6.5,287	59	87
	12		CL	2,W	1019.5	6.4,280	64	70
	13		CL	2,W	1019.9	6.7,288	61	75
	14		CL	2,W	1017.2	6.4,290	64	69
	15		CL	2,W	1017.4	6.7,288	61	78
	16		CL	2,W	1017.0	1.5,286	70	65
	17		CL	1,W	1016.6	2.1,284	68	67
	18		CL	1,W	1016.4	1.2,263	68	73
	19		CL	1,W	1016.1	2.4,304	65	76
	20		CL	1,W	1016.3	2.4,285	65	75
	21		CL	1,W	1016.9	2.0,59	64	81
	22		CL	1,W	1017.0	3.9,68	63	85
23		CL	1,W	1016.9	1.7,10	62	91	

D	HR(PDT)	CH	CT	S(ft,dir)	P(mb)	W(m/s,deg)	T(F)	RH%
9/21	00		CL	calm	1017.0	1.5,35	62	76
	01		CL	calm	1016.3	2.0,40	62	85
	02		CL	calm	1016.2	4.2,131	62	93
	03		CL	calm	1016.0	2.2,135	62	87
	04		CL	1,W	1016.8	3.0,60	62	82
	05		CL	1,W	1016.6	1.6,77	62	75
	06		CL	1,W	1016.9	3.5,287	62	73
	07		CL	2,W	1017.2	2.0,319	62	80
	08		CL	4,NW	1017.6	3.0,285	60	84
	09		CL	5,NW	1017.7	3.5,287	61	77
	10		CL	4-5,NW	1016.8	3.5,289	62	75
	11		CL	4,NW	1016.4	1.6,120	62	75
	12		CL	4,NW	1015.5	7.5,275	64	73
	13		CL	4,NW	1015.0	7.9,275	59	88
	14		CL	3-4,NW	1014.0	5.5,251	63	78
	15		CL	2-3,NW	1013.1	3.0,220	64	76
	16		CL	2-3,NW	1013.2	2.7,190	64	76
	17		CL	2-3,NW	1012.9	4.8,260	63	80
	18		CL	2-3,NW	1012.5	6.5,254	64	77
	19		CL	3,NW	1012.4	6.3,266	63	80
	20		CL	2-3,NW	1012.3	4.5,240	63	79
	21		CL	2-3,NW	1012.6	2.3,58	62	85
	22		CL	1-2,W	1013.0	1.0,70	62	86

no reports all evening

9/22	08		CL	1-2,W	1014.5	3.0,140	64	70
	09		CL	1,W	1013.3	2.3,135	68	67
	10		CL	1,W	1013.7	3.5,200	68	68
	11		CL	1,W	1014.1	3.3,135	65	75
	12		CL	1-2,W	1013.9	2.3,225	70	81
	13		CL	1-2,W	1013.7	1.0,200	66	72
	14		CL	1-2,W	1013.0	1.8,215	69	83
	15		CL	1-2,W	1012.7	2.4,234	69	68
	16		CL	2-3,W	1014.0	2.8,70	68	69
	17		CL	2-3,W	1013.8	3.8,276	66	73
	18		CL	2,W	1013.7	0.4,215	67	75
	19		CL	1-2,W	1013.9	0.3,198	62	89
	20		CL	1-2,W	1014.4	1.0,218	62	86
	21		CL	1-2,W	1014.2	1.4,198	62	87
	22		CL	1-2,W	1014.3	3.4,220	60	93
	23		CL	2-3,W	1014.3	4.5,27	61	91

D	HR(PDT)	CH	CT	S(ft,dir)	P(mb)	W(m/s,deg)	T(F)	RH%
9/23	00	M	ST4	2-3,W	1014.7	1.3,67	61	88
	01	M	ST4	1-2,W	1015.0	1.9,253	62	88
	02		CL	1-2,W	1015.0	2.1,83	61	88
	03		CL	1-2,W	1014.6	3.3,21	61	71
	04		CL	1-2,W	1014.3	6.4,20	61	65
	05		CL	1-2,W	1013.9	1.6,320	61	78
	06		CL	1-2,W	1014.2	1.5,140	60	74
	07	M,H	ST2,CI2	0-1,W	1014.9	0.3,200	60	80
	08	L	FOG	0-1,W	1015.7	1.8,117	60	86
	09	L	FOG	1,W	1016.8	1.9,309	60	86
	10	L	FOG	1-2,W	1017.0	3.5,300	60	82
	11	H	ST2	2-3,W	1016.8	5.5,290	64	70
	12	H	ST2	1-2,W	1016.6	3.2,270	62	78
	13	H	ST2	1,W	1016.4	1.6,195	67	66
	14	H	ST2	2-3,W	1016.0	6.9,270	64	72
	15	H	ST2	2,W	1015.5	1.5,280	65	75
	16	H,M	ST3,CI3	3,W	1016.6	3.3,255	68	68
	17	M	ST6	3,W	1016.0	2.6,260	66	70
	18	M	ST6	1-2,W	1016.0	1.7,350	63	84
	19	M	CU5	3,W	1015.8	1.5,220	64	82
	20	M	CU8	2,W	1015.9	1.0,300	64	76
	21	M	CU8	4,W	1016.0	7.6,315	64	67
	22	M	CU8	3-4,W	1015.8	4.8,292	63	72
23	M	CU8	3,W	1015.3	1.8,348	67	53	
9/24	00		CL	3,W	1015.6	5.9,308	62	73
	01		CL	3,W	1015.9	8.7,327	58	92
	02	L	FOG	4-5,NW	1017.2	10.6,339	58	98
	03	L	FOG	4-5,NW	1016.9	9.5,360	58	96
	04	L	FOG	3,NW	1016.9	8.6,343	56	99
	05	L	FOG	3,NW	1016.2	9.1,340	56	99
	06	L	FOG	3,NW	1016.8	8.4,335	56	99
	07	L	FOG	3,NW	1016.8	8.6,334	56	99
	08	L	FOG	3,NW	1016.9	8.0,346	54	99
	09	L	FOG	3-4,NW	1017.0	8.1,334	54	99
	10	L	FOG	6,NW	1017.1	8.5,344	55	98
	11		CL	3,NW	1016.8	6.9,322	56	97
	12		CL	2,NW	1017.0	3.0,180	61	85
	13		CL	3,W	1016.9	7.0,330	64	58
	14		CL	2-3,W	1016.2	3.0,35	67	60
	15		CL	2,W	1016.5	2.5,138	68	59
	16	M,H	CU2,CI2	1,W	1016.8	1.0,70	72	49
	17	M,H	CU2,CI2	1,W	1016.7	0.7,60	72	45
	18	M,H	CU4,CI4	1,W	1016.5	0.5,60	70	50
	19	M	CU4	1,W	1016.1	0.6,60	69	58
	20	M	CU5	1,W	1016.5	0.8,100	68	62
	21	M	CU4	1,W	1016.9	2.3,54	66	73
	22	M	CU3	1,W	1016.3	3.3,91	66	56
23	M	CU3	1,W	1016.2	3.4,119	67	54	

D	HR(PDT)	CH	CT	S(ft,dir)	P(mb)	W(m/s,deg)	T(F)	RH%
9/25	00	M	CU2	1,W	1016.2	1.1,92	67	64
	01	M	CU2	1,W	1015.8	1.6,150	65	65
	02	M	CU1	1,W	1015.5	5.1,95	67	44
	03		CL	1,W	1015.4	4.0,126	67	69
	04		CL	1,W	1015.1	3.3,90	64	61
	05		CL	1,W	1014.0	4.2,110	65	60
	06		CL	1,W	1014.1	4.3,93	63	55
	07		CL	1,W	1014.3	3.3,330	64	58
	08	L	ST6	calm	1014.6	5.7,93	65	58
	09	L	ST6	1,W	1014.9	5.3,119	66	58
	10	L	FOG	1,W	1015.6	4.0,110	67	53
	11	L	FOG	1,W	1015.6	4.5,130	67	56
	12	L	FOG	1,W	1015.4	3.8,103	67	59
	13		CL	1,W	1015.1	3.5,105	66	79
	14	H	CU2	1-2,W	1014.9	5.5,105	68	73
	15	M	CU3	1,W	1014.2	3.5,105	68	76
	16	M	CU1	1,W	1014.6	5.5,105	69	72
	17	M	CU2	1,W	1014.3	3.2,107	70	72
	18	L	ST4	1,W	1014.3	2.0,110	69	75
	19	L	ST7	1,W	1014.3	3.7,88	68	80
	20	L	ST2	1,W	1014.4	4.0,97	67	88
	21	L	ST1	1,W	1014.6	2.7,114	66	90
	22	M	ST6	1,W	1014.8	4.8,154	66	77
23	M	ST6	1,W	1015.2	3.5,180	68	73	
9/26	00	M	ST8	1,W	1015.5	4.2,210	63	90
	01	M	ST8	1,W	1015.5	5.7,205	63	93
	02	M	ST8	1-2,W	1015.6	2.7,187	62	89
	03	M	ST8	1-2,W	1015.6	4.2,185	62	80

LIST OF ILLUSTRATIONS

- Figure 1. Schematic of the RV Acania layout for SCCAMP.
Lower, forward mast is approximately 5 m. Upper mast is approximately 20 m. Overall ship length is 130 ft.
- Figure 2. Schematic of EPG's pendulum/accelerometer device.
- Figure 3. Chart of SCCAMP Intensive Area with the six RV Acania monitoring positions. For exact positions, consult table 4.
- Figure 4. Example of in situ data output used for screening.
- Figure 5. Mean wind speed, wind direction, and relative humidity during 1st week of SCCAMP. Data points represent 10 minute averages every 1 hour. Solid line is speed (m/s). Dashed line is direction/10 (deg true). Dotted line relative humidity/10 (%).
- Figure 6. Same as Fig. 5, except 2nd week of SCCAMP.
- Figure 7. Same as Fig. 5, except 3rd week of SCCAMP.

Figure 8. 10 minute average friction velocities plotted every hour for 1st week of SCCAMP. Dashed, single dot is 5 m turbulence method (m/s). Dashed, double dot is 20 m turbulence method. Solid line is 20 m bulk method.

Figure 9. Same as fig. 8 except for 2nd week of SCCAMP.

Figure 10. Same as Fig. 8 except for 3rd week of SCCAMP.

Figure 11. 10 minute average sensible heat flux, latent heat flux, and z/L at 20 m plotted every hour for 1st week of SCCAMP. Dotted line is non-dimensional stability *100. Dashed line is sensible heat flux (W/m^2). Solid line is latent heat flux (W/m^2).

Figure 12. Same as fig. 11, except for 2nd week of SCCAMP.

Figure 13. Same as fig. 11, except for 3rd week of SCCAMP.

Figure 1.

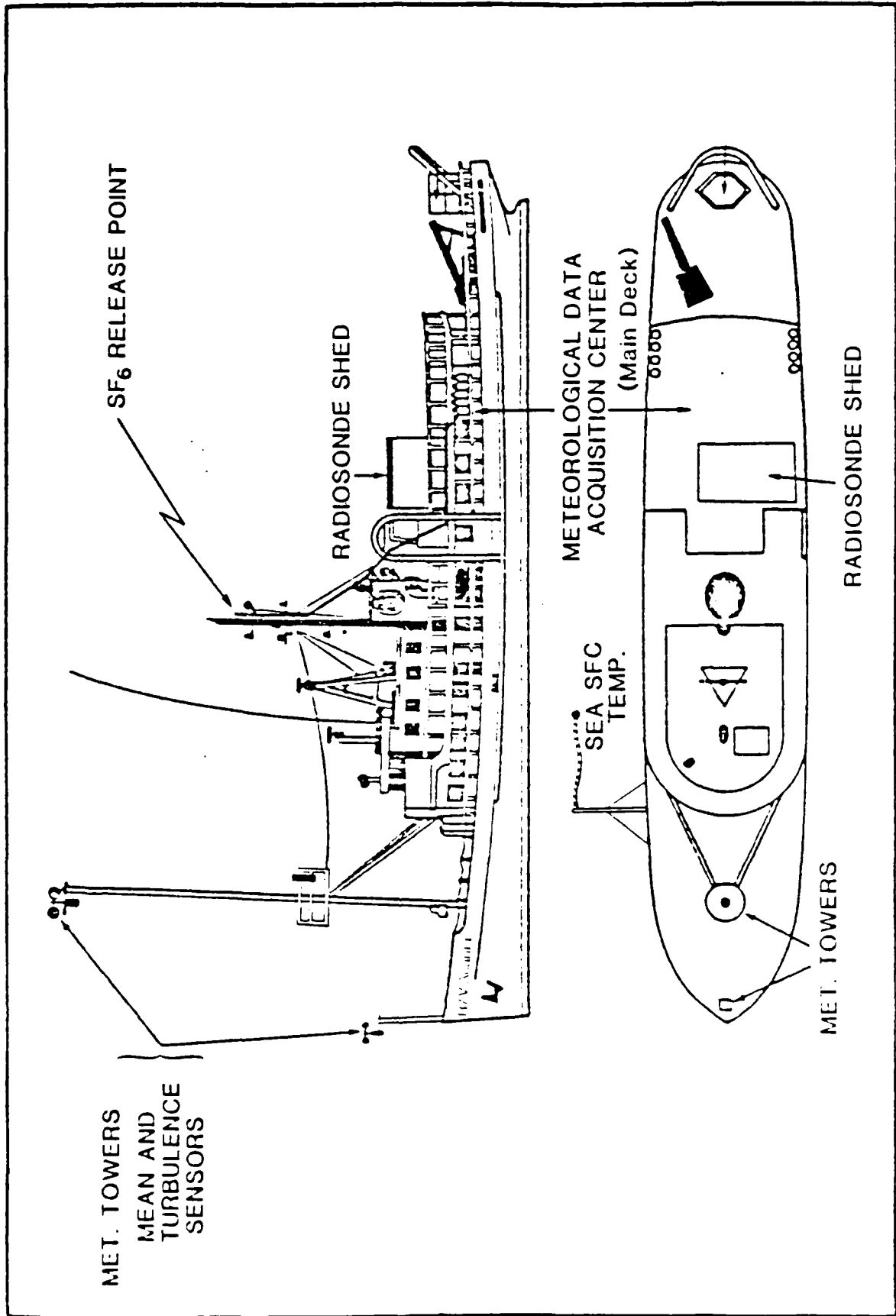

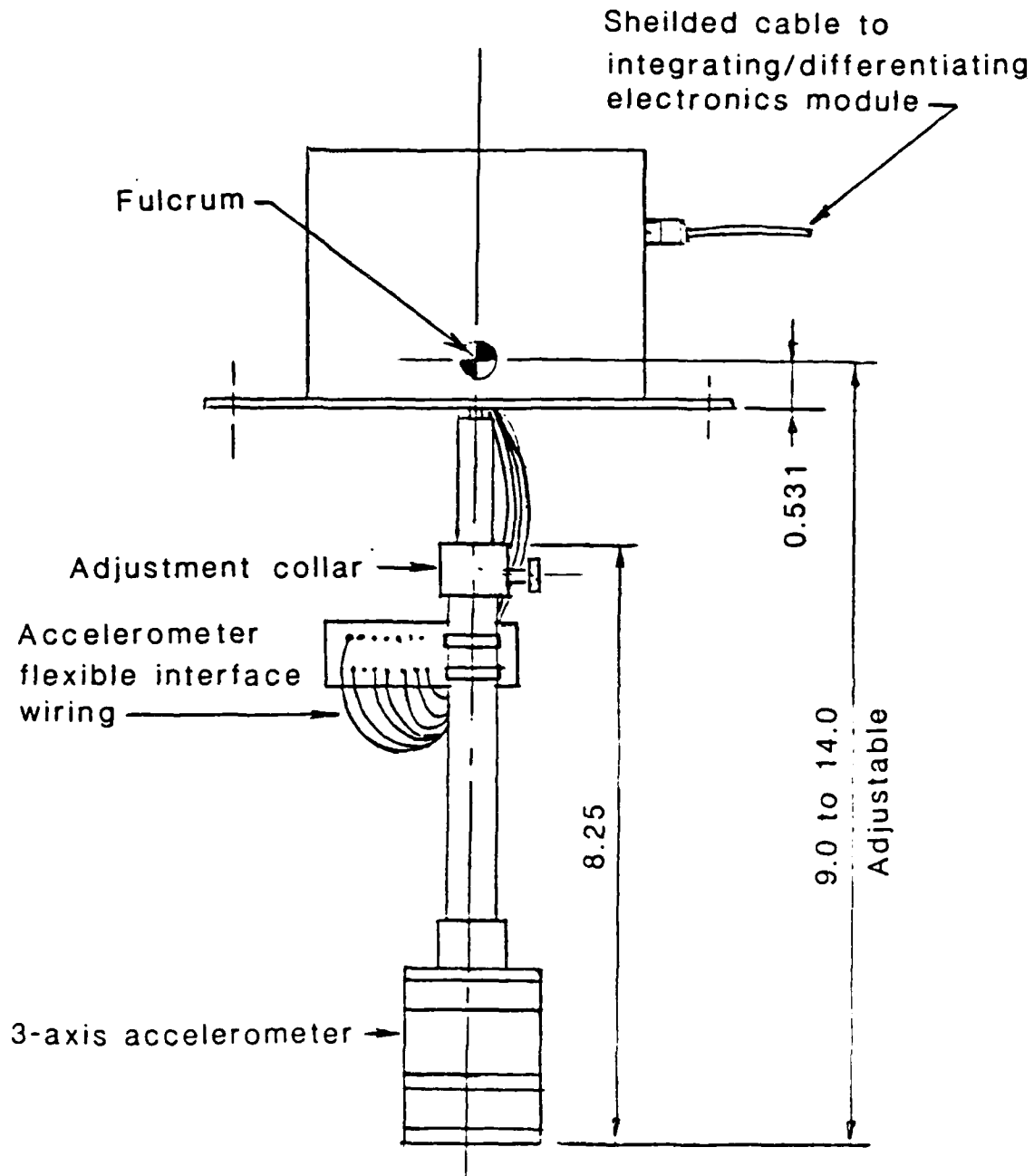

Note: Dimensions are in inches

SANTA YNEZ MOUNTAINS

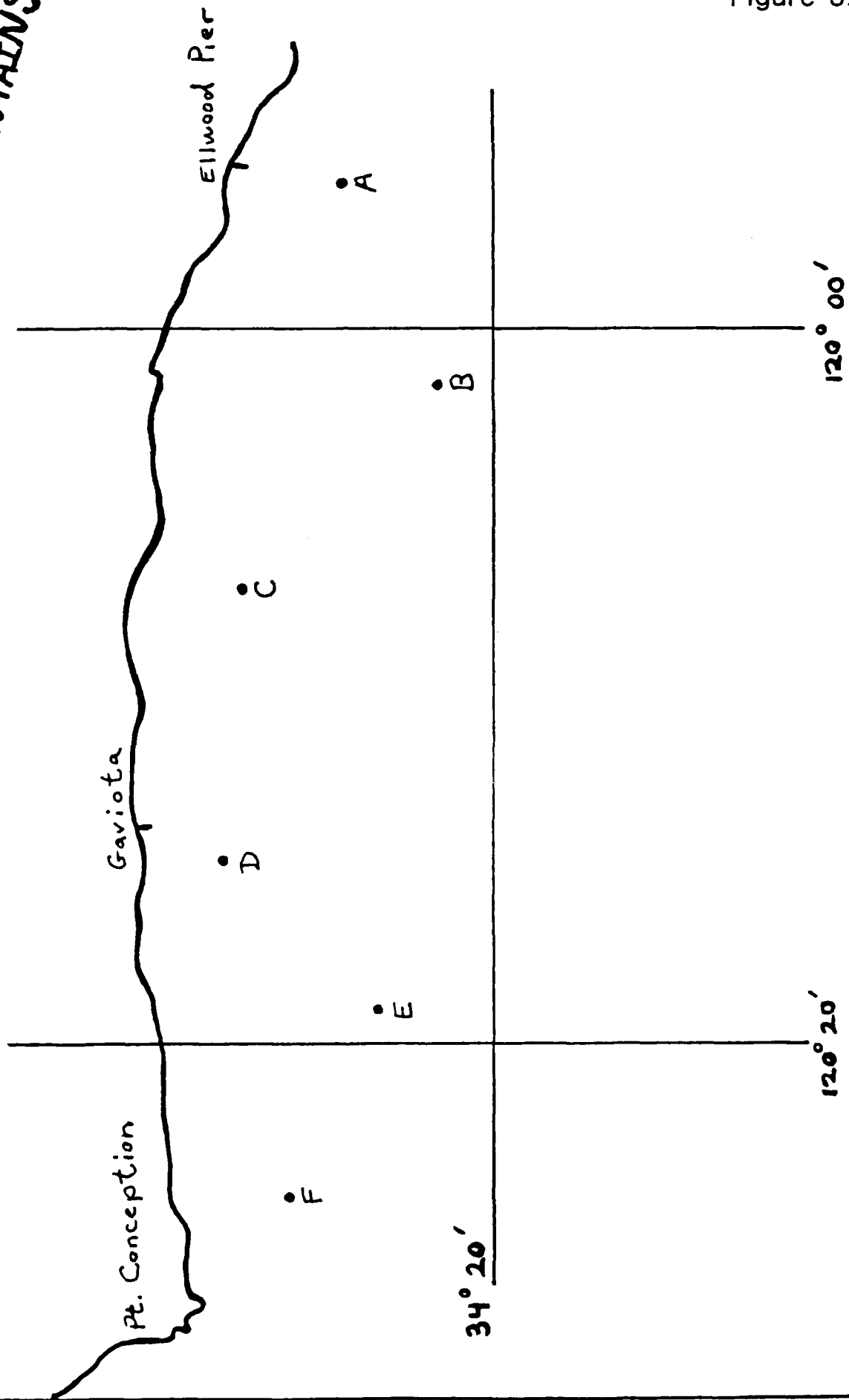

Figure 3.

Figure 4.

23 SEP 1985 19:30:00 9000CAMP95 DISC 9 RECORD 51

***** measurements *****

			MEAN	SIGMA	
#fast	19				
#slow	596				
location	34.2550 N	pitch	24.87	2.23	deg
(deg.min/decmin)	120.0750 W	roll	36.61	2.24	
ship speed	3.40 m/s	pitchrate	-1.30	4.67	deg/s
heading	273 deg true	rollrate	-1.55	1.46	
sea sfc temp	17.18 deg C	vawrate	0.00	0.00	
bow air temp	18.32	heave x	-1.16	.06	m/s
main air temp	19.29	heave y	1.00	.13	
bow dew temp	15.52	heave z	-5.65	.17	
main dew temp	13.76	bow hotfm	3.29	.07	volts
bow cups	5.70 m/s rel	main hotfm	7.80	.20	
main cups	6.04	bow bi sp	5.99	.87	m/s rel
bow vane	20 deg rel	main bi sp	6.56	1.11	
main vane	14	bow bi el	-2.05	7.91	deg rel
bow hotfm RMSer	.33 volts	main bi el	-4.70	6.01	
main hotfm RMSer	.56	bow bi az	8	14.32	
sigma yaw	0.00 deg	main bi az	7	16.49	

***** calculations *****

low frequency cutoff	5 Hz	bow wind height	5.70 m
high frequency cutoff	50	main wind height	18.00
total RMSer gain	100.00	bow temp,dew ht	6.10
atmospheric pressure	1014.2 mb	main temp,dew ht	17.10
bow rel humidity	84 %	bow mixing ratio	11.17 g/kg
main rel humidity	70	main mixing ratio	9.97
bow bivane az true	292 deg	bow bivane sp true	2.57 m/s
main bivane az true	287	main bivane sp true	3.20

	:Dissipation Technique:		:Bulk calculations:		
	BOW	MAIN	BOW	MAIN	
M-0 length	+2.115E+01	+1.039E+01	+1.269E+01	+1.102E+01	m
Zou	+2.977E-04	+6.734E-03	+3.199E-05	+4.241E-05	
Zot.a	+2.000E-05	+2.000E-05	+2.000E-05	+2.000E-05	
Cd	+1.068E-03	+3.991E-04	+1.669E-03	+3.872E-03	non
Ct.a	+7.460E-04	+2.523E-04	+2.933E-03	+5.039E-03	
U star	+8.721E-02	+6.400E-02	+1.090E-01	+1.394E-01	m/s
B star	-3.397E-02	-3.380E-02	-6.736E-02	-1.734E-01	g/kg
T star	+3.267E-02	+3.613E-02	+6.478E-02	+1.615E-01	deg K
epsilon	+7.348E-04	+3.148E-04	(n) 2(s) -3		
dynamic B'	+2.568E+00	+1.439E+01	(volts) 2(m/s) ² -1/2		
sensible H	+3.246E-01	+2.569E-01	watts(m) -2		
latent H	-8.848E+00	-7.955E+00			

***** sigma pairs ***** RECORD 51

	BOW	MAIN	
WIND VECTORS			
bivane sig speed meas	.57	1.11	m/s
bivane sig speed true	.51	1.01	
sig speed true (quick)	.58	0.00	
bivane sig theta meas	24.32	16.49	deg
bivane sig theta true	24.68	26.49	
sig theta true (quick)	32.04	33.46	
bivane sig phi meas	7.91	6.01	
bivane sig phi true	16.60	14.92	
sig phi true (quick)	10.52	7.35	
sig phi rotation	2.39	2.35	(sig az=sig yaw)
SHIP VECTORS	U	V	W
sigma measured	1.18	.95	.81
sig due to rotation	.53	.17	1.47
sigma true	1.21	.96	.95
sig due to acceleration	.06	.18	.17

Figure 5.

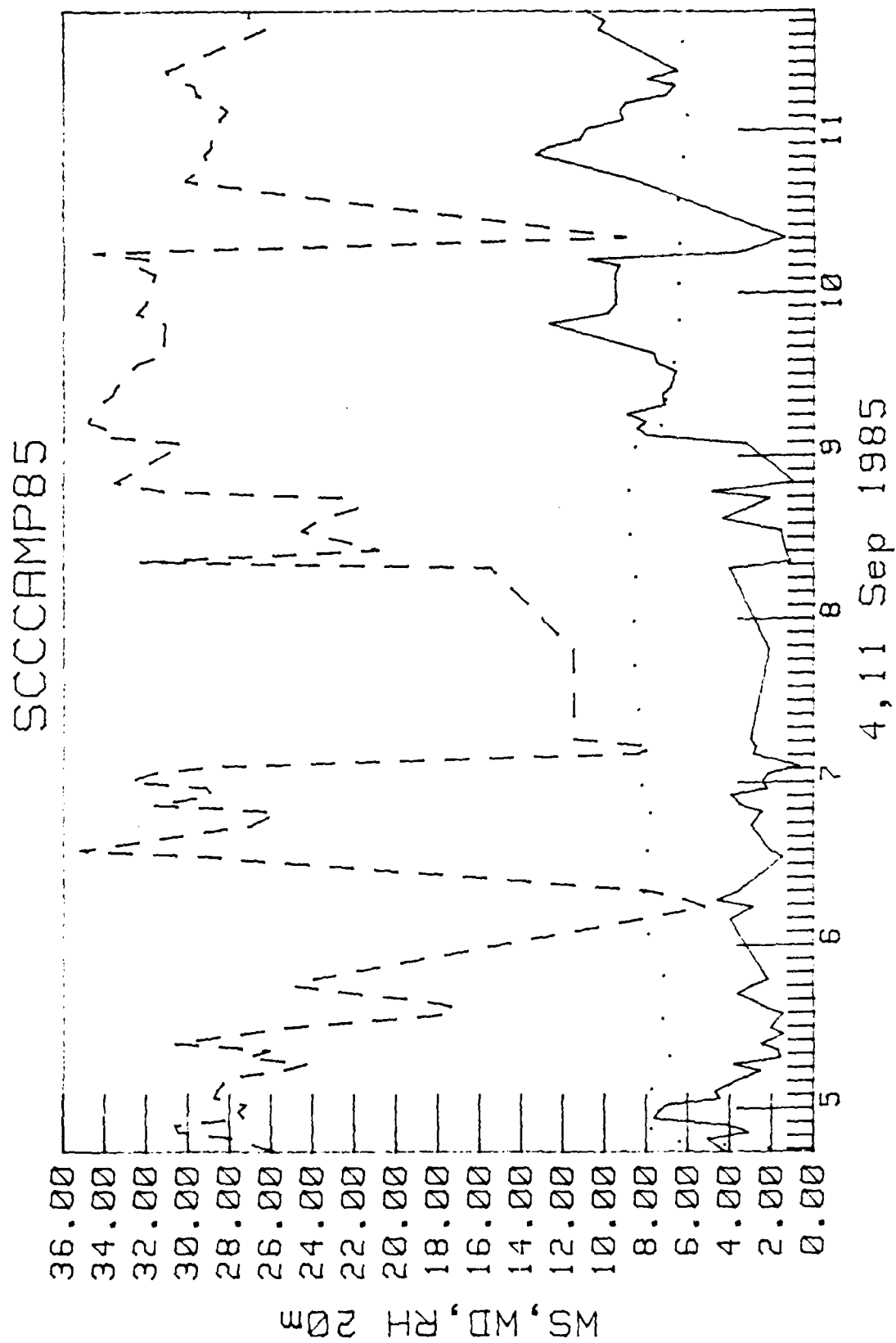

Figure 6.

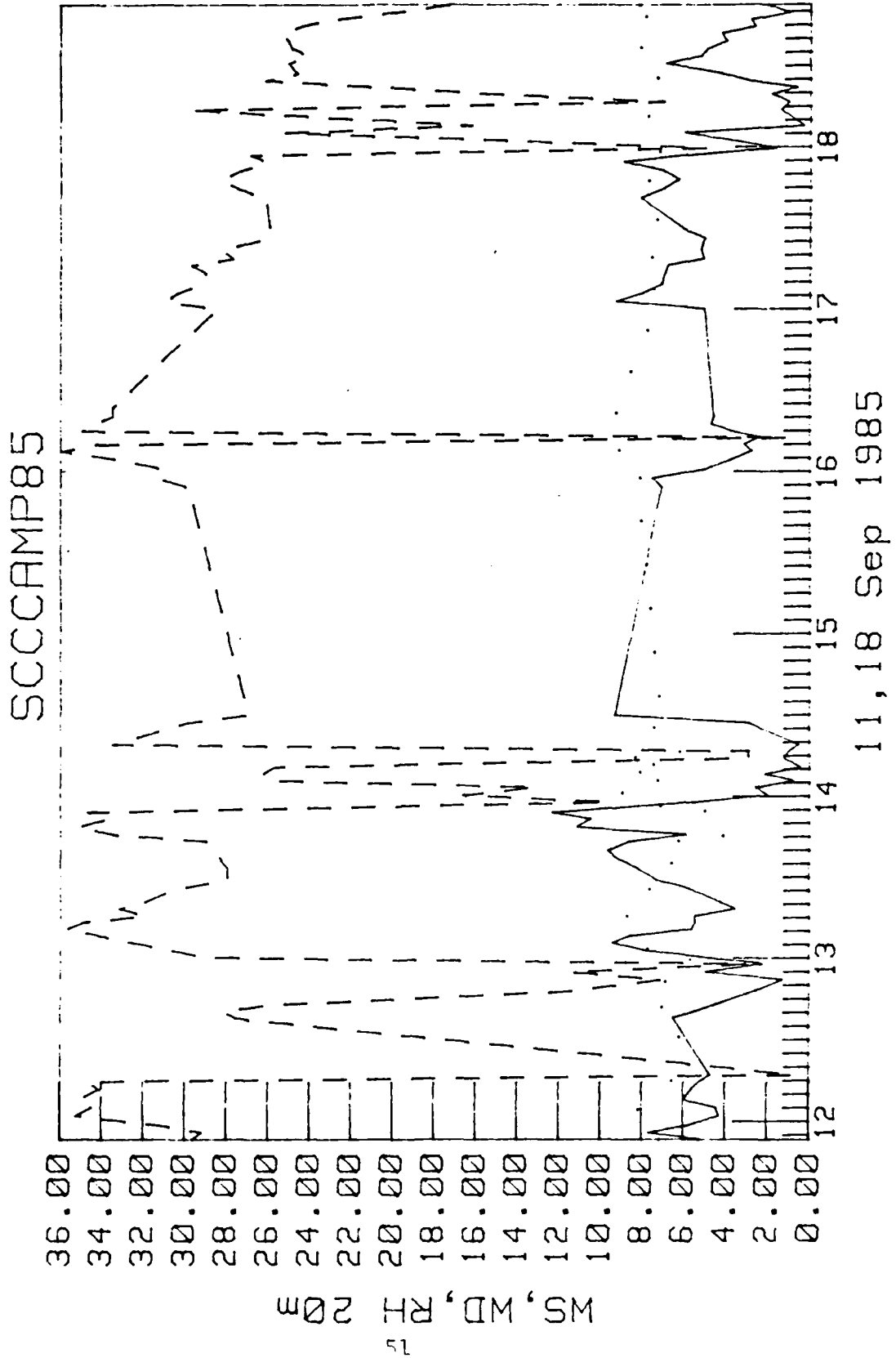

Figure 7.

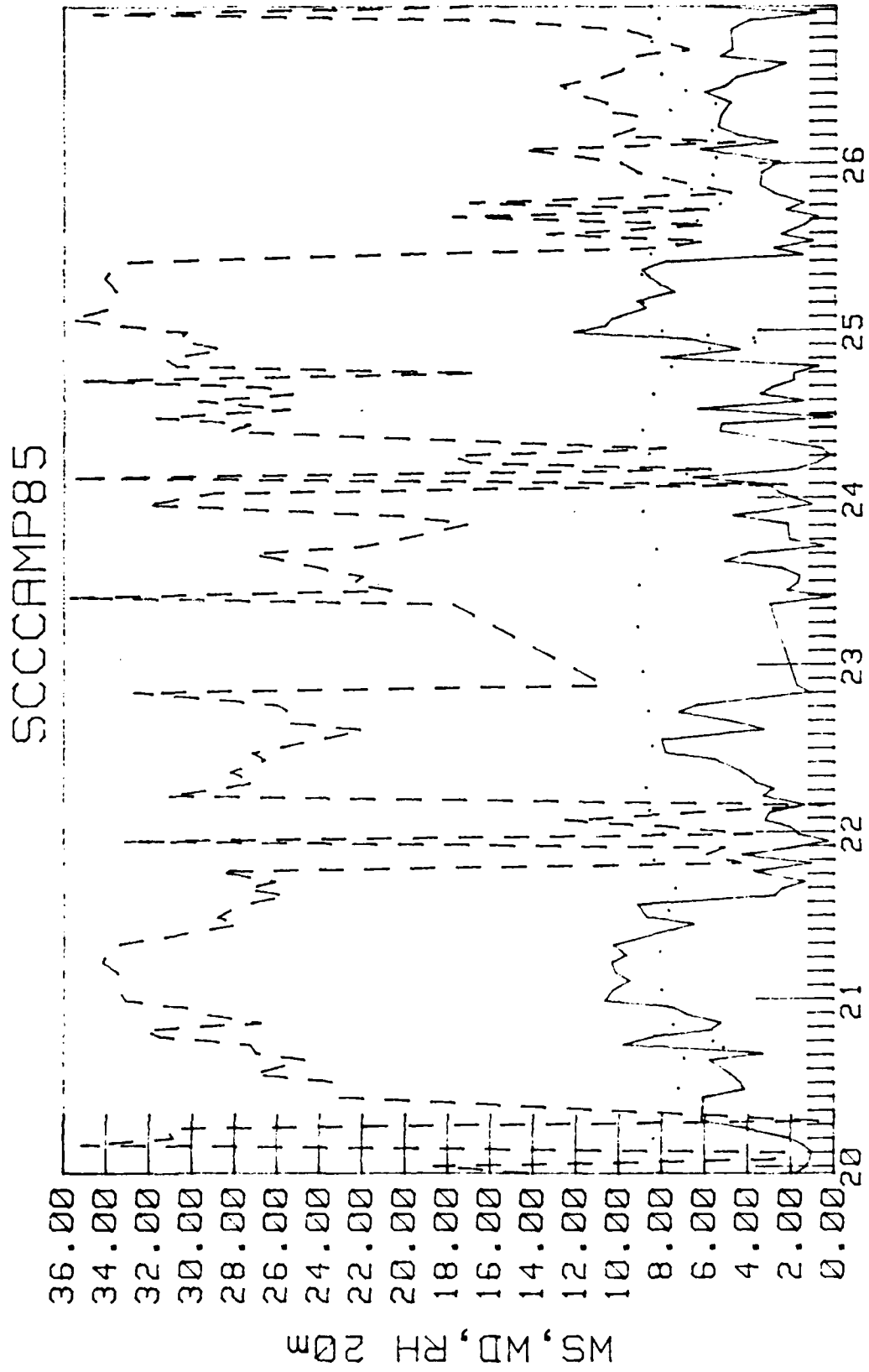

Figure 8.

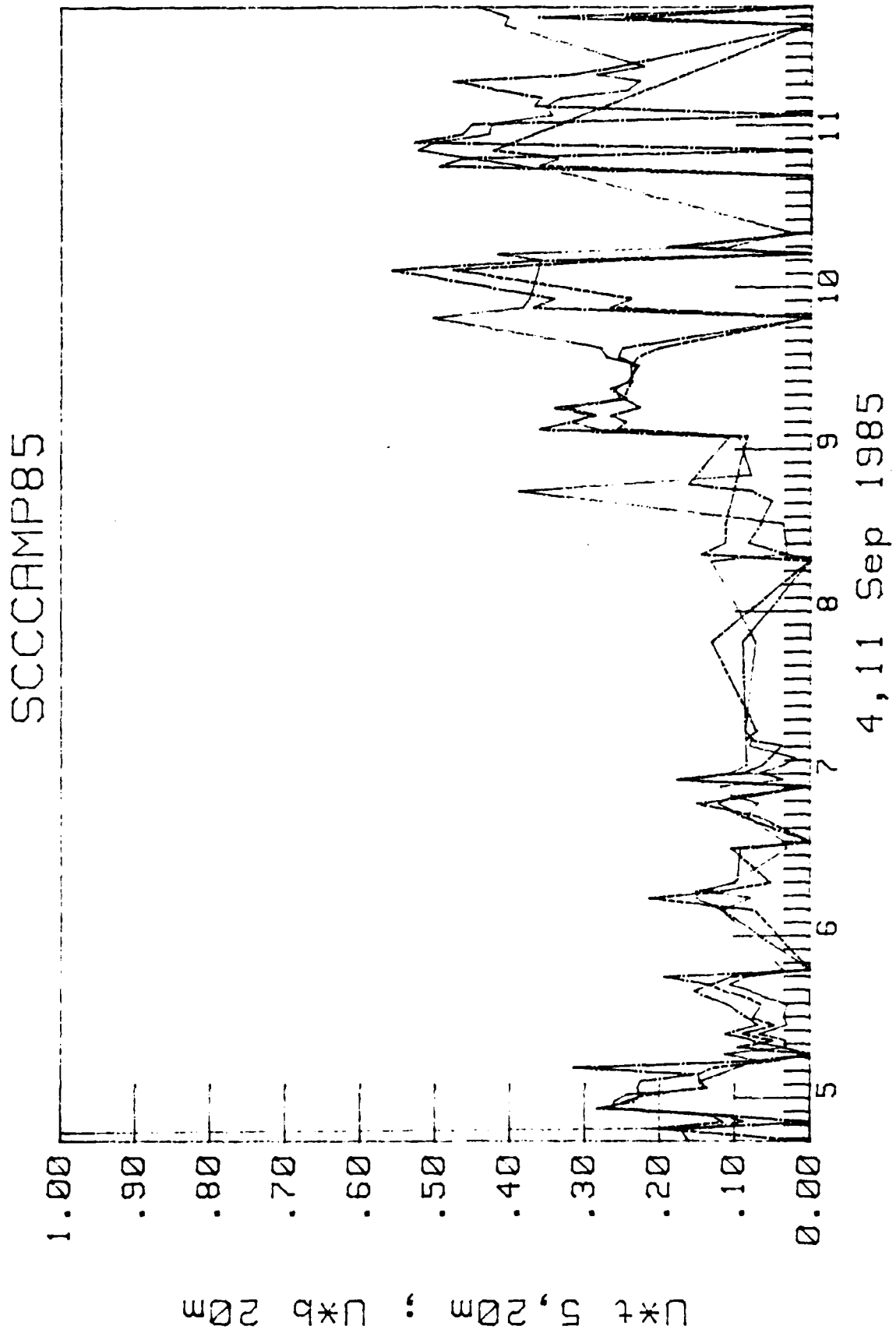

Figure 9.

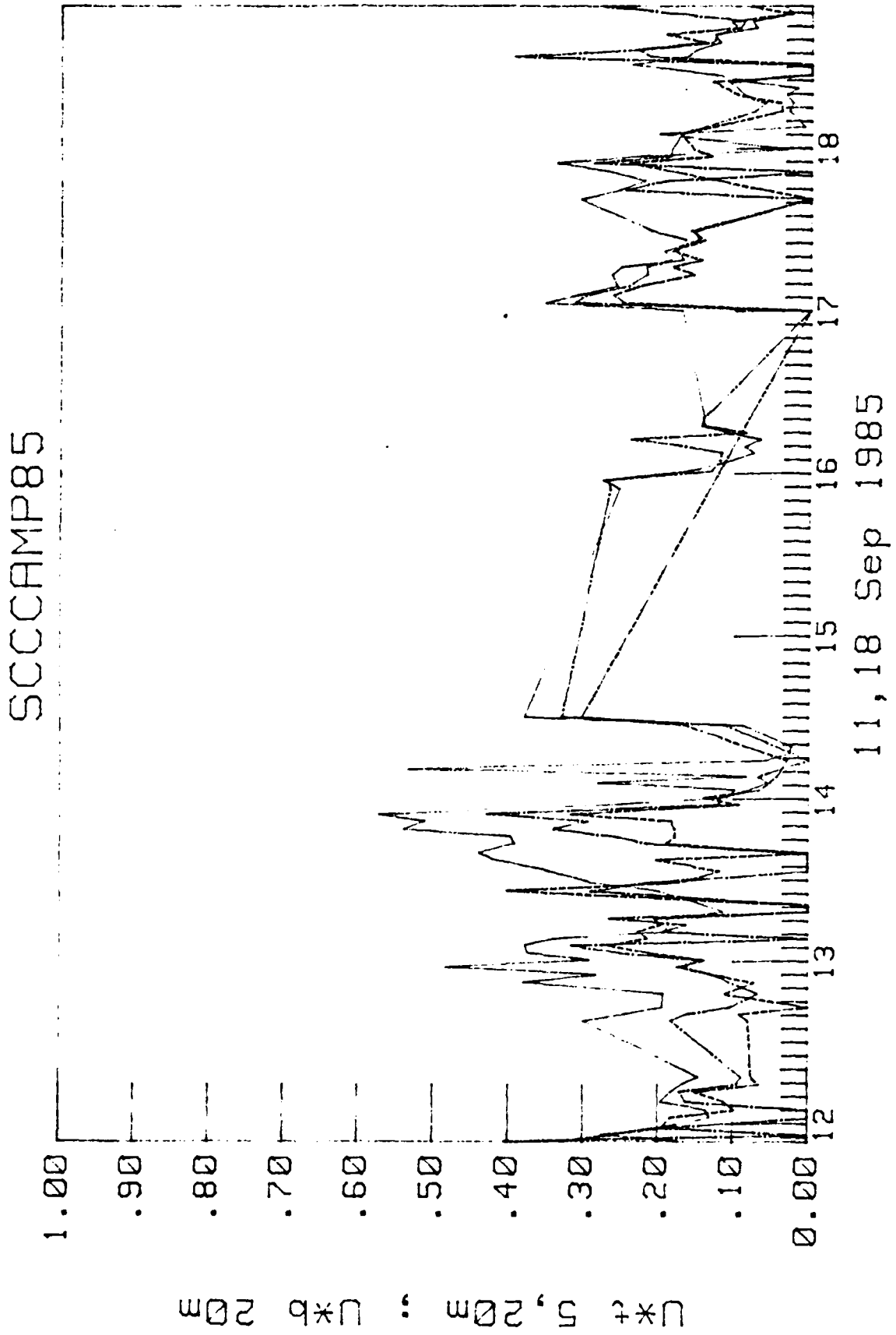

Figure 10.

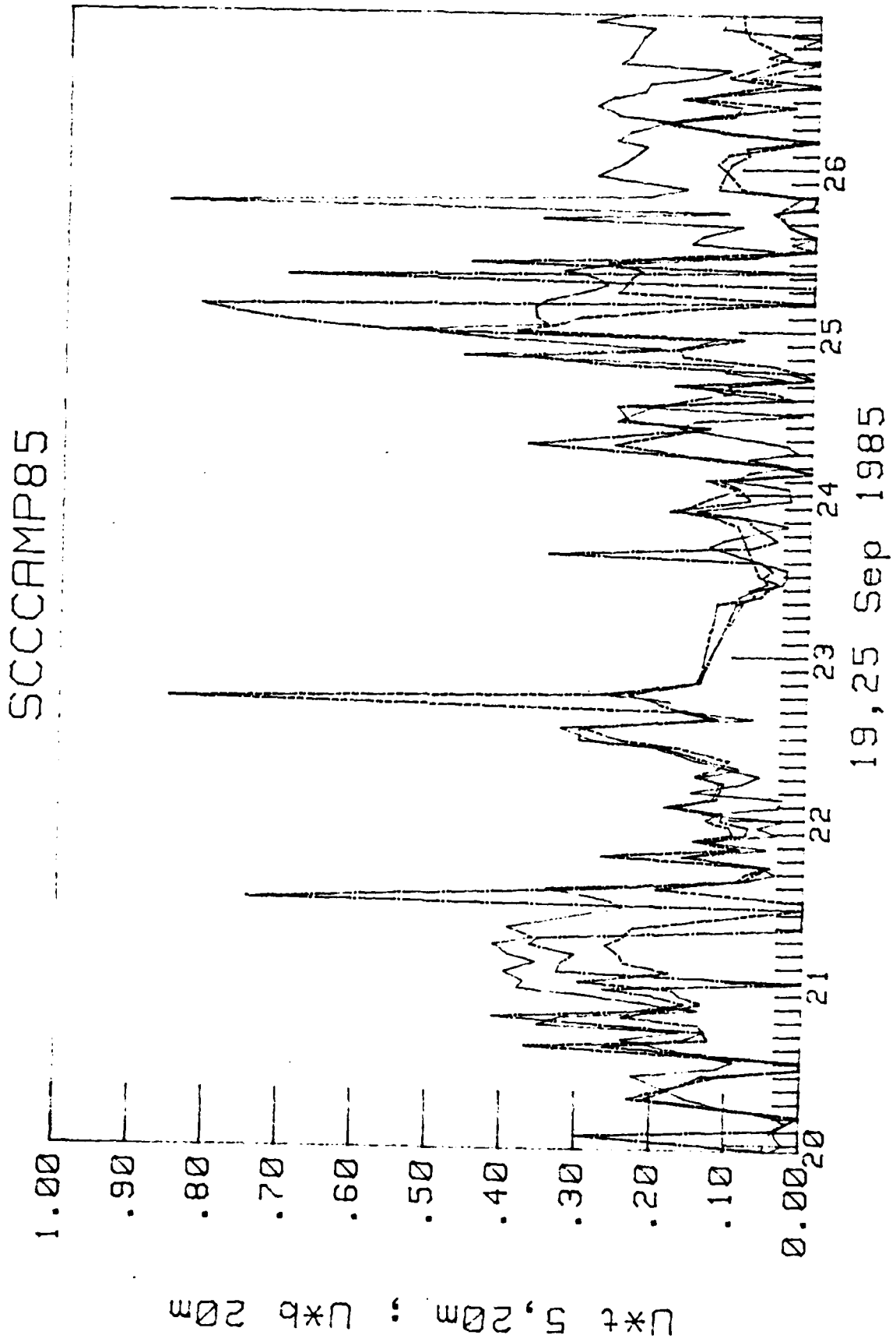

Figure 11.

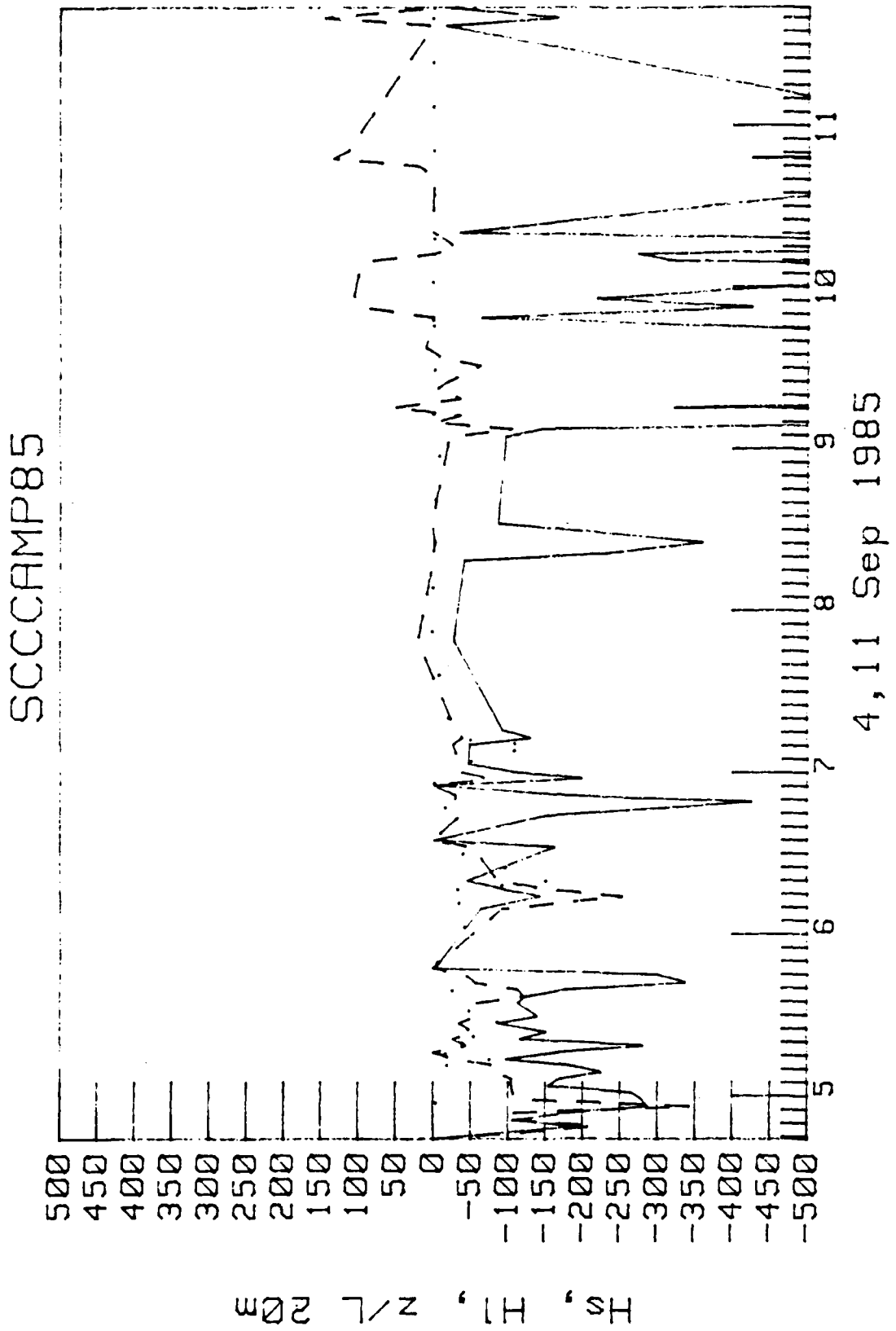

Figure 12.

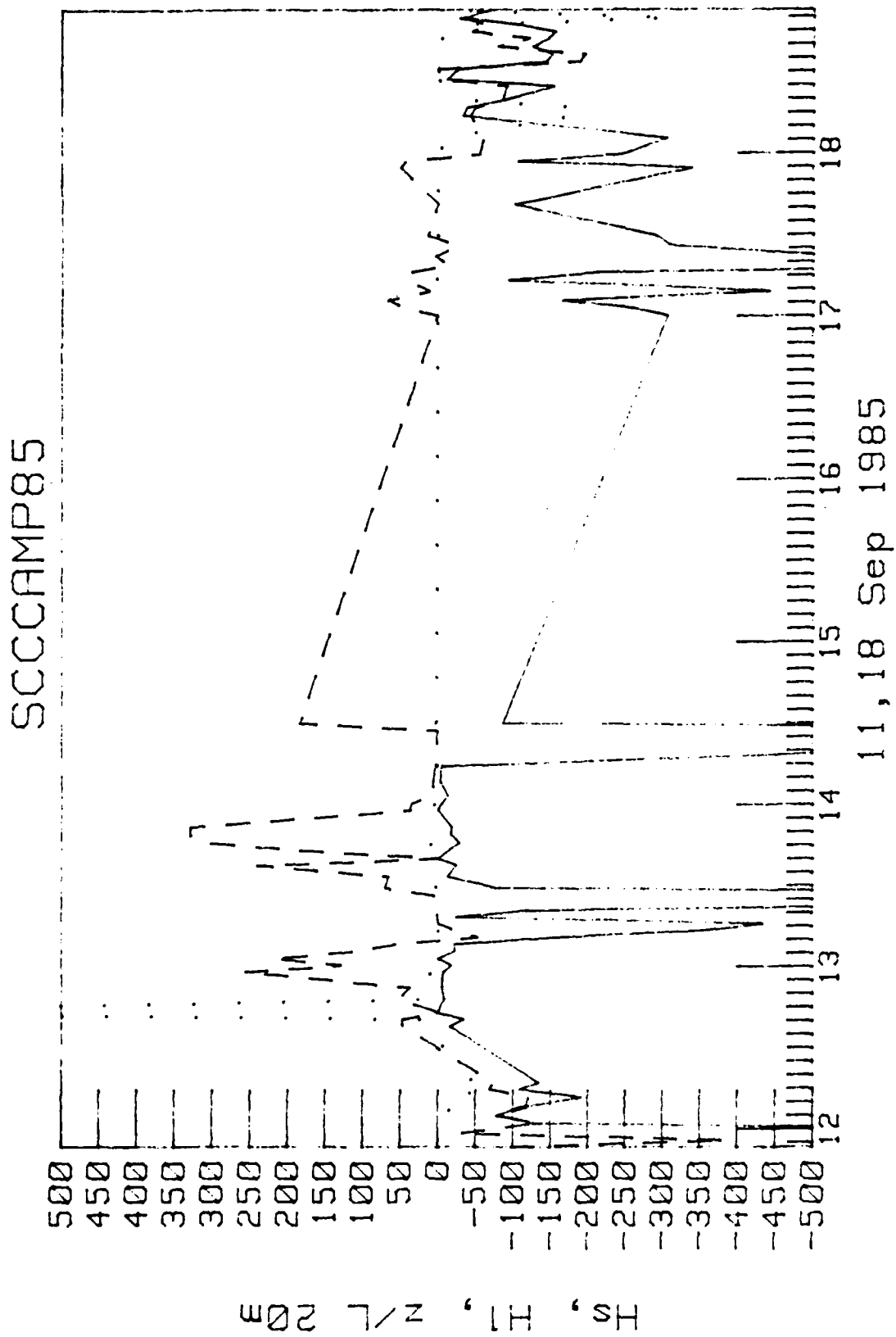
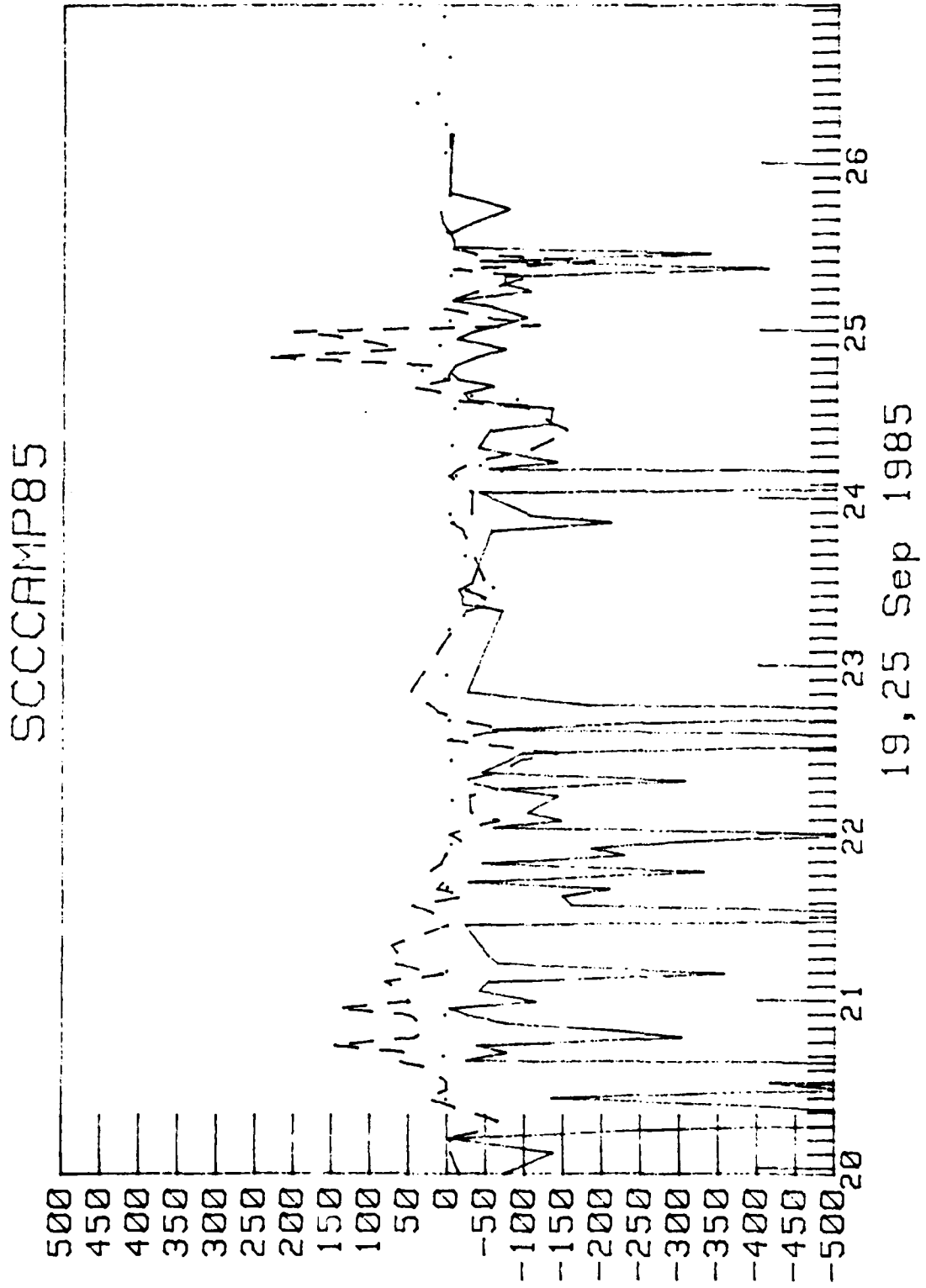

Figure 13.



IS, FI, N/L 203

REFERENCES

- Dabberdt, W. F., W. Viezee, and K. C. Nitz (1985): SCCAMP Field Study Design. Volume I. Monitoring Network. SRI Project 8331, Published by SRI International, Menlo Park, CA 94025-3493.
- Kondo, J. (1975): Air-Sea Bulk Transfer Coefficients over Oceans and Continents. *Boundary Layer Meteorol.* 9, 91-112.
- Large, W. G. and S. Pond (1981): Open Ocean Momentum Flux Measurements in Moderate to Strong Winds. *J. Phys. Oceanogr.* 11, 324-336.
- McBean, G. A. and J. A. Elliott (1975): The Vertical Transports of Kinetic Energy by Turbulence and Pressure in the Boundary Layer. *J. Atmos. Sci.* 32, 753-766.
- Schacher, G. E., K. L. Davidson, and C. W. Fairall (1982): Atmospheric Marine Boundary Layer Convective Mixing Velocities in the California Coastal Region. *Atmos. Environ.* 16-5, 1183-1191.
- Shaw, W. S., S. Borrmann, C. Fellbaum, C. E. Skupniewicz, C. A. Vaucher, and G. T. Vaucher (1986): SODAR, Rawinsonde, and Surface Layer Measurements at a Coastal Site: SCCAMP Data Report, Part II. NPS Technical Report (in press)
- Wyngaard, J. C. and O. R. Cote (1971): The Budgets of the Turbulent Kinetic Energy and Temperature Variance in the Atmospheric Surface Layer. *J. Atmos. Sci.* 28, 190-201.

APPENDIX A.

Removing Ship Motion Contributions from Measured Bivane Turbulence

Motions of the measurement platform can significantly alter the bivane turbulence measurements. As part of an ongoing effort at EPG-NPS, ship motions were measured and calculations were performed to adjust turbulence values appropriately.

Two basic approaches were attempted. The first, referred to as the "long method", corrects each individual sample vectorially. The second, called the "quick method", operates only on the variances at the end of a measurement period.

The long method is the most direct approach. The first task is to transform the instantaneous (every 1 sec) wind vector into ship coordinates where u and v are horizontal components aligned parallel and perpendicular to the ship axis and w is the vertical component. Analogous components from the ship's motion are then computed and subtracted from measure values.

One obvious contribution of ship motions to measured turbulent velocities are velocities at the sensor due to the rotation of the vessel about its center of gravity. The following equation define the sensor velocities

$$u_r = - \frac{d\phi}{dt} (\sin \phi dx + \cos \phi dz) \quad (A1)$$

$$v_r = \frac{d\psi}{dt} \cos \psi dz + \frac{d\Omega}{dt} \cos \phi dx \quad (A2)$$

$$w_r = \frac{d\phi}{dt} (-\sin \phi \cos \psi dz + \cos \phi dx) \quad (A3)$$

$$- \frac{d\psi}{dt} \cos \phi \sin \psi dz - \frac{d\Omega}{dt} \cos \phi \sin \psi dx$$

where u_r and v_r are horizontal vectors due to "rotation" with u_r positive in the forward ship direction and v_r positive to the right and perpendicular to ship direction. ϕ is pitch angle, ψ is roll angle and Ω is yaw angle. dx and dz are moment arms from the ship center of gravity axis' to the sensor. Wind speeds created by these sensor velocities will, of course, be opposite in sign. Note that w_r has contributions from pitch, roll, and yaw angular velocities. Pitch rates do not contribute to v_r , while u_r is not affected by either roll or yaw rates. Each sensor will be affected differently, due to the different moment arms.

A second contribution to sensor velocities arises from accelerations of the entire measurement platform. These velocities are obtained from the integrated accelerometer outputs. Since the accelerometer coordinate system (mounted on the pendulum) is identical to the u, v, w coordinates described above, no coordinates transformation is necessary.

A third contribution to the u and w components comes from the mean velocity of the ship as follows:

$$u_s = U_s \cos \phi \quad (A4)$$

$$w_s = U_s \sin \phi \quad (A5)$$

where subscript s refers to "ship". While these are trivial calculations, they can be very significant when ship speed approaches the wind speed.

A final contribution to variance comes from the absolute turning of the platform without considerations to apparent wind. This component depends on the relative (measured) wind vector as follows:

$$u_t = u_m \sin \phi \quad (A6)$$

$$v_t = v_m \sin \psi \quad (A7)$$

$$w_t = w_m \sin \gamma \quad (A8)$$

where

$$\gamma = \phi \cos A_{rel} - \psi \sin A_{rel} \quad (A9)$$

and A_{rel} is the relative azimuthal wind direction. Subscript t refers to "turning" and m refers to "measured".

All of the above calculations are performed for every sample and then subtracted from the measured components to obtain the "true" wind components. The standard deviation of true wind components in ship coordinates are supplied in the SCCAMP data set (word nos. 125-130). True angular and absolute speed

standard deviations are also supplied (word nos. 139-144). The standard deviations of the rotational and accelerational components are given in word nos. 116-124.

The "quick" method of removing ship motions from the bivariate turbulence operates only on variances of relevant quantities at the end of a measurement period. The sample by sample calculations of the "long" method are avoided at the expense of making the assumption that ship motion terms are not correlated. This major assumption is most likely incorrect, but was applied as a check on the long method.

Components of variances due to rotational velocities were calculated in ship coordinates as in the long method. The rotational components are obtained by operating on the measured standard deviation of the rate angles, and eqs. A1-A3 simplify to

$$(u_r)_{\text{RMS}} = \left(\frac{d\phi}{dt}\right)_{\text{RMS}} dz \quad (\text{A10})$$

$$(v_r)_{\text{RMS}} = \left(\frac{d\psi}{dt}\right)_{\text{RMS}} dz + \left(\frac{d\Omega}{dt}\right)_{\text{RMS}} dx \quad (\text{A11})$$

$$(w_r)_{\text{RMS}} = \left(\frac{d\phi}{dt}\right)_{\text{RMS}} dx \quad (\text{A12})$$

where RMS refers to the "root mean squared" value (standard deviation). Acceleration components need no transformation, as in the long method.

The rotational and accelerational components are then transformed into polar wind vector coordinates. The rotational equations are

$$(S_r)_{\text{RMS}}^2 = (u_r)_{\text{RMS}}^2 \cos^2 A_{\text{rel}} + (v_r)_{\text{RMS}}^2 \sin^2 A_{\text{rel}} \quad (\text{A13})$$

$$(A_r)_{\text{RMS}}^2 = \frac{(u_r)_{\text{RMS}}^2 \sin^2 A_{\text{rel}} + (v_r)_{\text{RMS}}^2 \cos^2 A_{\text{rel}}}{S_{\text{rel}}^2} \quad (\text{A14})$$

$$(E_r)_{\text{RMS}}^2 = \frac{(w_r)_{\text{RMS}}^2}{S_{\text{rel}}^2} \quad (\text{A15})$$

where S is speed, A is azimuthal angle, and E is elevation angle. Analogous equations are used for the accelerometer components. An additional term accounting for the platform tilt (not considering apparent winds) is also calculated as follows

$$(E_t)_{\text{RMS}}^2 = (\phi)_{\text{RMS}}^2 \cos^2 A_{\text{rel}} + (\psi)_{\text{RMS}}^2 \sin^2 A_{\text{rel}} \quad (\text{A16})$$

The measured directional variances are corrected for the effects of the ship mean velocity by normalizing to the true wind speed as follows

$$(A_c)_{\text{RMS}}^2 = \left(\frac{(A_m)_{\text{RMS}} S_{\text{rel}}}{S_{\text{true}}} \right)^2 \quad (\text{A17})$$

$$(E_c)_{\text{RMS}}^2 = \left(\frac{(E_m)_{\text{RMS}} S_{\text{rel}}}{S_{\text{true}}} \right)^2 \quad (\text{A18})$$

where subscript m refers to "measured" and c refers to "corrected." Finally, ship motion variances are subtracted from the measured variances to obtain the "true" variances.

INITIAL DISTRIBUTION LIST

	No. of Copies
1. Mr. C. E. Skupniewicz, Code 61 Naval Postgraduate School Monterey, California 93943	10
2. Mr. Peter Guest, Code 63 Naval Postgraduate School Monterey, California 93943	1
3. Professor K. L. Davidson, Code 63Ds Naval Postgraduate School Monterey, California 93943	1
4. Asst. Professor W. J. Shaw, Code 63 Naval Postgraduate School Monterey, California 93943	10
5. Professor Robert Renard, Code 63Rd Naval Postgraduate School Monterey, California 93943	1
6. Professor G. Schacher, Code 61Sq Naval Postgraduate School Monterey, California 93943	1
7. Mr. Stephan Borrmann, Code 63 Naval Postgraduate School Monterey, California 93943	1
8. Miss Sheryl Fellbaum, Code 63 Naval Postgraduate School Monterey, California 93943	1
9. Mr. Christopher Vaucher, Code 63 Naval Postgraduate School Monterey, California 93943	1
10. Mrs. G. Tirrell Vaucher, Code 63 Naval Postgraduate School Monterey, California 93943	1
11. Mr. Tom Cornwell, Environmental Coordinator 727 West Seventh Street, Suite 850 Los Angeles, California 90017	5

	No. of Copies
12. Defense Technical Information Center Cameron Station Alexandria, Virginia 22314	2
13. Mr. Alex Beaker Dames & Moore 222 E. Anapamu Street Santa Barbara, California 93101	1
14. Dr. Ann Berman ERT 7700 E. Araphoe Rd. Englewood, CA 80112	1
15. Dr. Ron Cionco Atmospheric Sciences Lab WSMR, New Mexico 80002	1
16. Dr. Walt Dabberdt National Center for Atmospheric Research P. O. Box 3000 Boulder, Colorado 80307	1
17. Mr. Dan Goddin ERT 975 Business Center Circle Newbury Park, California 21320	1
18. Dr. Steven Hannah 533 Hill Road Boxborough, Massachusetts 01719	1
19. Dr. Dirk Herkoff Pacific Outer Continental Shelf Office Minerals Management Service 1340 W. 6th Street, Room 200 Los Angeles, California 90017	1
20. Dr. Welf Augin Kampe German Military Geophysical Office Mont Royal D-5580 Traben-Trarbach FEDERAL REPUBLIC OF GERMANY	1
21. Dr. Donald L. Shearer TRC Environmental Consultants, Inc. 8775 E. Orchard Road, Suite 816 Englewood, Colorado 80111	1

	No. of Copies
22. Mr. Mark J. Stunder 20251 Century Blvd. Germantown, MD 20874	1
23. Library, Code 0142 Naval Postgraduate School Monterey, California 93943	2
24. Research Administration Office Code 012 Naval Postgraduate School Monterey, California 93943	1

ENTRICK

7-86