

NATIONAL BUREAU OF S
MICROCOPY RESOLUTION TEST

2

OPERATIONAL CONCEPT DOCUMENT
FOR THE
BATTLE MANAGEMENT/COMMAND, CONTROL & COMMUNICATIONS (BM/C3)
GRAPHICAL DISPLAYS

CONTRACT NO.: DASG60-86-C-0036

CDRL SEQUENCE NO.: A004

15 MAY 1986

DTIC
ELECTE
MAY 30 1986
S D
A

Prepared for:

US ARMY STRATEGIC DEFENSE COMMAND
SYSTEMS DEVELOPMENT DIRECTORATE

AD-A168 209



DTIC FILE COPY

This document has been approved
for public release and sale; its
distribution is unlimited.

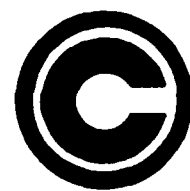

COLSA, INC.

1535 Sparkman Drive
Huntsville, Alabama 35816

86 5 29 042



COLSA, INC.

1535 Sparkman Drive / Huntsville, Alabama 35816 / (205) 830-5412

30 May 1986

Commander
U.S. Army Strategic Defense Command
DODA Code: W31RPD
ATTN: DASD-H-SBD
P.O. Box 1500
Huntsville, Alabama 35807

SUBJECT: Letter of Transmittal

Attached is the Operational Concept Document (A004) for Contract DASG60-86-C-0036, USASDC Battle Management, Architecture Definition Office Battle Management/Command, Control and Communications (BM/C3) Graphical Displays.

Sincerely,



Dr. James C. Hayes
Program Manager

Attachment: as

cc: DASD-H-MPL (with enclosure)
DTIC (with two enclosures)
SETAC (with two enclosures)
IDA (with enclosure)
SDIO/ST (with enclosure)
DASD-H-CRT (without enclosure)
DCASMA-Birmingham (without enclosure)

COLSA, INC.

Mailing Address: P.O. Box 1068, Huntsville, Alabama 35807-3301

UNCLASSIFIED

SECURITY CLASSIFICATION OF THIS PAGE

AD-A168209

REPORT DOCUMENTATION PAGE

| | | | |
|---|--|--|----------------------------------|
| 1a. REPORT SECURITY CLASSIFICATION UNCLASSIFIED | | 1b. RESTRICTIVE MARKINGS None | |
| 2a. SECURITY CLASSIFICATION AUTHORITY | | 3. DISTRIBUTION/AVAILABILITY OF REPORT UNCLASSIFIED/UNLIMITED | |
| 2b. DECLASSIFICATION/DOWNGRADING SCHEDULE | | | |
| 4. PERFORMING ORGANIZATION REPORT NUMBER(S) BMC3-0036-8601 | | 5. MONITORING ORGANIZATION REPORT NUMBER(S) | |
| 6a. NAME OF PERFORMING ORGANIZATION COLSA, Inc. | 6b. OFFICE SYMBOL (If applicable) | 7a. NAME OF MONITORING ORGANIZATION DCASMA-Birmingham | |
| 6c. ADDRESS (City, State and ZIP Code) 1535 Sparkman Dr. P.O. Box 4710 Huntsville, AL 35815-4710 | | 7b. ADDRESS (City, State and ZIP Code) 2121 8th Avenue, North Birmingham AL 35203-2376 | |
| 8a. NAME OF FUNDING/SPONSORING ORGANIZATION | 8b. OFFICE SYMBOL (If applicable) | 8. PROCUREMENT INSTRUMENT IDENTIFICATION NUMBER | |
| U.S. Army Strategic Def Cnd | DASD-H-SBD | DASG60-86-C-0036 | |
| 9a. ADDRESS (City, State and ZIP Code) P.O. BOX 1500 HUNTSVILLE AL 35806 | | 10. SOURCE OF FUNDING NOS. | |
| | | PROGRAM ELEMENT NO. | PROJECT NO. |
| | | TASK NO. | WORK UNIT NO. |
| 11. TITLE (Include Security Classification) Opn. Concept Doc. for BM/C3 Graphical Dis. | | | |
| 12. PERSONAL AUTHOR(S) Pharr, Owen Ferrell | | | |
| 13a. TYPE OF REPORT Initial | 13b. TIME COVERED FROM 860331 TO 860516 | 14. DATE OF REPORT (Yr., Mo., Day) 860515 | 15. PAGE COUNT 28 |
| 16. SUPPLEMENTARY NOTATION Meets CDRL A004 Requirement for a "Display Graphics Report" | | | |
| 17. COSATI CODES | | 18. SUBJECT TERMS (Continue on reverse if necessary and identify by block number) | |
| FIELD | GROUP | SUB. GR. | |
| | | BM/C3 GRAPHICAL DISPLAYS, Command Decision Aids, and SDI BM/C3 | |
| 19. ABSTRACT (Continue on reverse if necessary and identify by block number) This report provides the operational concepts directing the development of graphical displays and command decision aids. These displays are for use with the SIMSTAR, Tactical Warning/Attack Assessment (TW/AA), and Defense-In-Depth Simulation (DIDSIM) simulation. They are used in the analysis of BM/C3 concepts, architectures, and deployments associated with the SDI. <i>Keywords include:</i> | | | |
| 20. DISTRIBUTION/AVAILABILITY OF ABSTRACT UNCLASSIFIED/UNLIMITED <input checked="" type="checkbox"/> SAME AS RPT. <input type="checkbox"/> DTIC USERS <input type="checkbox"/> | | 21. ABSTRACT SECURITY CLASSIFICATION UNCLASSIFIED | |
| 22a. NAME OF RESPONSIBLE INDIVIDUAL Michael Gately | | 22b. TELEPHONE NUMBER (Include Army Code) (205) 895-3181 | 22c. OFFICE SYMBOL DASD-H-SBD |

DD FORM 1473, 83 APR

EDITION OF 1 JAN 73 IS OBSOLETE.

UNCLASSIFIED
SECURITY CLASSIFICATION OF THIS PAGE

OPERATIONAL CONCEPT DOCUMENT
FOR THE
BATTLE MANAGEMENT/COMMAND, CONTROL & COMMUNICATIONS (BM/C3)
GRAPHICAL DISPLAYS

CONTRACT NO.: DASG60-86-C-0036

CDRL SEQUENCE NO.: A004

15 MAY 1986

Prepared for:

US ARMY STRATEGIC DEFENSE COMMAND
SYSTEMS DEVELOPMENT DIRECTORATE



PREPARED BY:
COLSA, INC.
1535 Sparkman Drive
Huntsville, AL 35816

| | |
|--------------------|-------------------------------------|
| Approved for | <input checked="" type="checkbox"/> |
| Noted | <input type="checkbox"/> |
| DTIC PAS | <input type="checkbox"/> |
| Unannounced | <input type="checkbox"/> |
| Justification | <input type="checkbox"/> |
| By _____ | |
| Distribution/ | |
| Availability Codes | |
| Dist | Avail and/or Special |
| A-1 | |

TABLE OF CONTENTS

| PARAGRAPH | PAGE |
|---|------|
| Table of Contents | ii |
| List of Figures | iv |
| 1. SCOPE | 1 |
| 1.1 Identification | 1 |
| 1.2 Purpose | 1 |
| 1.3 Introduction | 2 |
| 2. REFERENCED DOCUMENTS | 3 |
| 2.1 Government Documents | 3 |
| 2.2 Other Documents | 3 |
| 3. MISSION | 4 |
| 3.1 Mission Need Requirement | 4 |
| 3.2 Mission | 7 |
| 3.3 Operational Environment | 7 |
| 3.4 Support Environment | 7 |
| 4. SYSTEM FUNCTIONS AND CHARACTERISTICS | 8 |
| 4.1 System Functions | 8 |
| 4.1.1 Planning Information | 8 |
| 4.1.1.1 Preplanned Strategies | 8 |
| 4.1.1.2 Rules of Engagement | 8 |
| 4.1.1.3 Defense Value Structure | 9 |
| 4.1.1.4 Higher Authority | 9 |
| 4.1.2 Defense System | 11 |
| 4.1.2.1 System Architecture | 11 |
| 4.1.2.2 System Status | 11 |
| 4.1.3 Threat Information | 12 |
| 4.1.3.1 Launch Detection | 12 |
| 4.1.3.2 Fast Burner Identification | 12 |
| 4.1.3.3 Booster Identification | 12 |
| 4.1.3.4 Booster Payload | 12 |
| 4.1.3.5 RV Identity | 12 |
| 4.1.3.6 Impact Locations | 14 |
| 4.1.3.7 Threat Success Rate | 14 |
| 4.1.4 Defense Operations | 14 |
| 4.1.4.1 Information Source Reliability | 14 |
| 4.1.4.2 Target Assignment | 14 |
| 4.1.4.3 Engagement Status and Kill Assessment | 16 |
| 4.1.4.4 Target Handover | 16 |
| 4.1.4.5 Saturation | 16 |
| 4.2 Computer System Functions | 16 |
| 4.2.1 Data and Information Collection | 16 |
| 4.2.2 Display Generation | 18 |
| 4.3 Operator and User Interaction | 18 |
| 4.3.1 Static Mode | 19 |
| 4.3.2 Dynamic Mode | 19 |
| 4.3.3 Dynamic, Interactive Mode | 19 |
| 4.4 Computer System Characteristics | 20 |

| PARAGRAPH | | PAGE |
|-----------|--------------------------------------|------|
| 4.4.1 | Hardware | 20 |
| 4.4.1.1 | DEC Equipment | 20 |
| 4.4.1.2 | MEGATEK | 20 |
| 4.4.2 | Software | 21 |
| 4.4.2.1 | DEC Standard Software | 21 |
| 4.4.2.1.1 | VAX/VMS | 21 |
| 4.4.2.1.2 | FORTRAN | 21 |
| 4.4.2.1.3 | PDL | 21 |
| 4.4.2.1.4 | CONMAN | 21 |
| 4.4.2.2 | MEGATEK Software | 22 |
| 4.4.2.3 | BM/C3 Applications Graphics Software | 22 |
| 4.4.2.3.1 | BM/C3 Display Graphics Executive | 23 |
| 4.4.2.3.2 | Initialization Unit (IU) | 23 |
| 4.4.2.3.3 | Graphic Utilities | 25 |
| 5. | GOVERNMENT AGENCIES | 26 |
| 6. | NOTES | 27 |
| 6.1 | Classified Material Disclaimer | 27 |
| 6.2 | Acronyms and Abbreviations | 27 |

List of Figures

| FIGURE | | PAGE |
|-----------|---|------|
| 3.1-1 | Phases of Ballistic Missile Flight | 5 |
| 3.1-2 | Multi-Level Strategic Defense System | 6 |
| 4.1.1.3-1 | Strategic Command Centers and Weapon Sites within CONUS | 10 |
| 4.1.3.1-1 | Soviet ICBM Bases and Missile Test Centers | 13 |
| 4.1.3.5-1 | Land Based Early Warning System | 15 |
| 4.2-1 | Proposed BM/C3 Graphical Displays Systems Flowchart | 17 |
| 4.4.3-1 | Applications Graphics Software Functional Diagram | 24 |

1. SCOPE

1.1 Identification. This Operational Concept Document (OCD) describes the mission of the Battle Management/Command, Control and Communications (BM/C3) Graphical Displays system as well as its operational and support environments. It also describes the functions and characteristics of the computer system to be utilized within the overall system.

1.2 Purpose. The BM/C3 Graphical Displays being developed will enhance the graphical display capabilities associated with three simulations developed by the Strategic Defense Command (SDC). These simulations are used to analyze and evaluate various BM/C3 concepts in strategic defense against ballistic missile systems. The three simulations are:

- o SIMSTAR
- o Defense-In-Depth Simulation (DIDSIM)
- o Tactical Warning/Attack Assessment (TW/AA)

SIMSTAR is used to model the capabilities, reliability, and survivability of C3 systems under varying conditions, including nuclear attack.

DIDSIM models the complete range of strategic defense functions. It provides the advantage of fidelity selectability among its component modules. Fidelity selectability serves to reduce simulation run time by limiting high fidelity modeling to the element under analysis, while other elements of the model operate with low or medium fidelity.

TW/AA initially modeled only the existing sensor system and its functions, including target assessment and times and locations of threat warhead impact. A module was added later to simulate Strategic Defense Initiative (SDI) functions and concepts.

The proposed graphical displays system will use data obtained from the simulations to develop information displays. However, it will not combine outputs from more than one simulation in the development of these displays. The information displayed will be determined by the data available from each of the simulations and by the information needs of decision makers performing battle management functions in a ballistic missile defense system war room environment. The graphical software must be able to use data derived from a simulation, produce the required information formatted for display, and display the information on color monitors and graphic printers.

1.3 Introduction. The US Army Strategic Defense Command (USASDC) requires an enhanced graphical display capability for its simulation efforts, and to assist in the comprehensive evaluation of the BM/C3 concepts it is modeling. This OCD shall identify the types of information to be graphically displayed as well as the expected environment and system where the BM/C3 Graphical Displays software will be used. The information to be developed and displayed will be that which best assists in the evaluation of BM/C3 concepts, and which would be essential to the decision formulation by battle managers operating within the framework of a strategic defense system. (See 6.1)

2. REFERENCED DOCUMENTS

2.1 Government Documents.

1. Scope of Work, Contract No. DASG60-86-C-0036, SW-H-39-85, 28 OCT 1985.
2. DOD-STD-2167, 4 JUN 1985.
3. JCS Pub 1, 1 APR 1984.
4. "BM/C3 Concept Guidelines Document", BMDSC, February 1986, SNF.
5. Soviet Military Power 1986, US Government Printing Office.

2.2 Other Documents.

3. MISSION

3.1 Mission Need Requirements. USASDC is one of the agencies charged with research and development efforts within the SDI. The most promising BM/C3 architectures are being developed around a concept of operations based on a multi-tiered defense. These tiers are designed to defend against ballistic missiles in all four phases of their flight: boost, post-boost, midcourse, and terminal (Fig. 3.1-1). Within each tier the defense must carry out a set of essential functions: surveillance, acquisition, and tracking; pointing and tracking of defense weapons; interception, destruction, and kill assessment of enemy offensive weapons; and battle management. The battle management function is manifested in the direction of the other functions and the accomplishment of the defense mission. The defense will be dependent on both ground and space based components and will be controlled through a multi-echeloned BM/C3 system. This multi-tiered concept is illustrated in Fig. 3.1-2.

A probable strategic defense BM/C3 command hierarchy begins with a global battle manager overseeing the operations of regional battle managers whose responsibilities are assigned either geographically, by defensive tier, or as a combination of both. The lowest BM node will be local battle managers who will control weapon and sensor systems. Man-in-the-loop may or may not exist at the local battle management level. The diversity and complexity of such a defense system will require a command, control and communications system capable of ensuring positive control of the defense system. This system must be capable of providing critical information in a manner easily assimilated and acted upon by decision makers performing battle management functions.

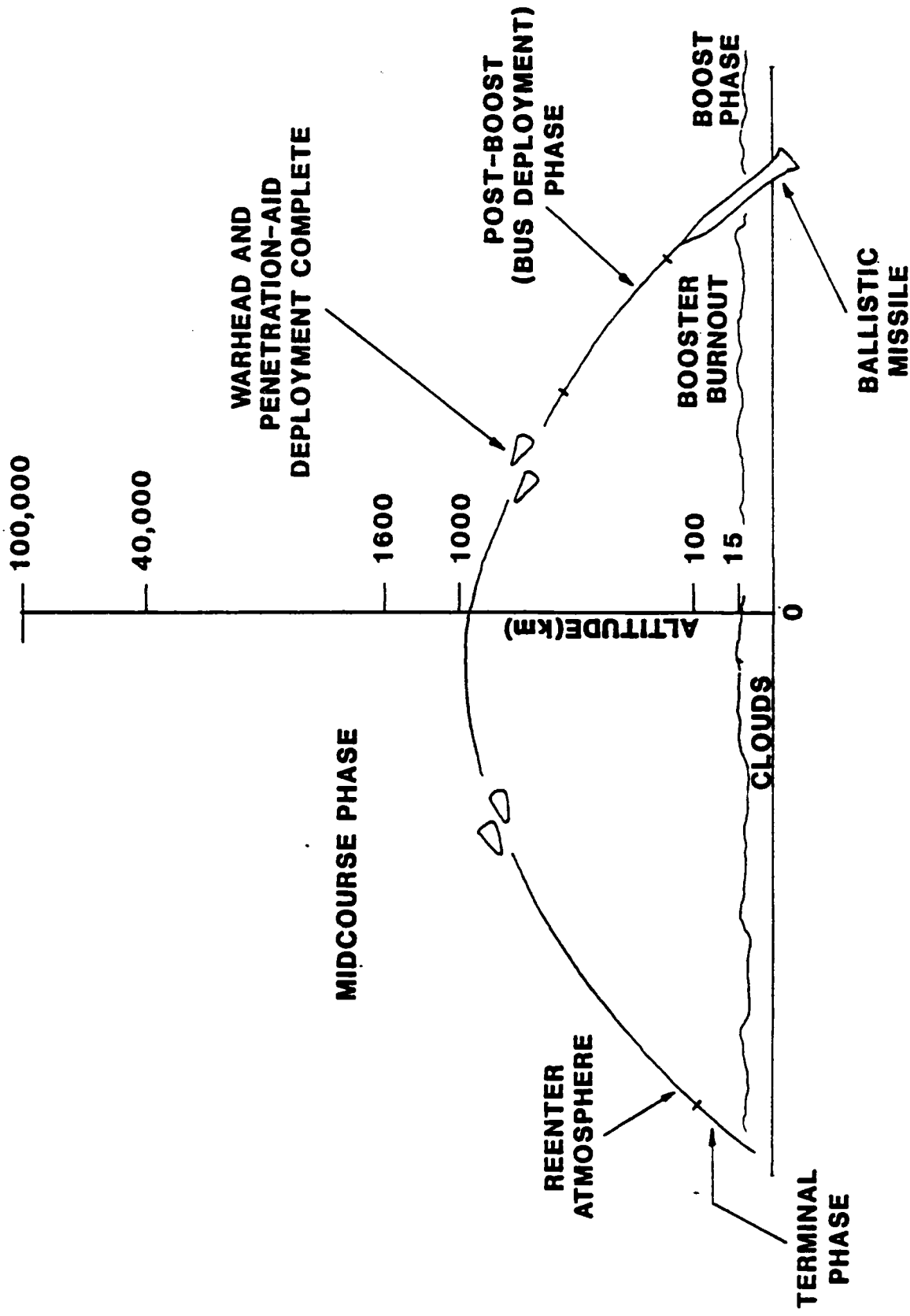

FIGURE 3.1-1 PHASES OF BALLISTIC MISSILE FLIGHT

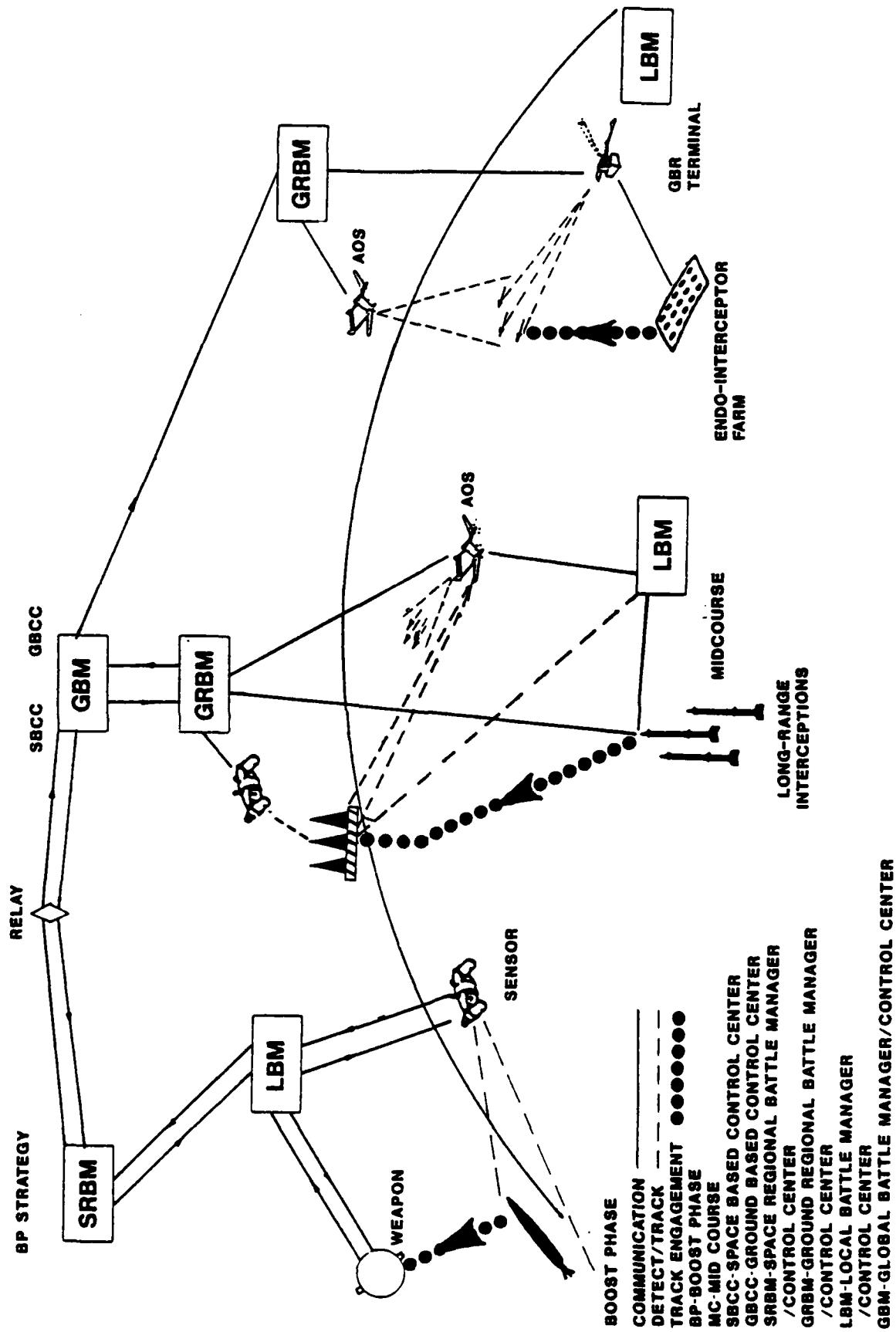

FIGURE 3.1-2 MULTI-LEVEL STRATEGIC DEFENSE SYSTEM

The need for information display also extends to the results obtained from computer simulations being used to study SDI BM/C3 issues. The displays must be capable of presenting the outputs of the simulations on color monitors and graphic printers. They must also aid in ballistic missile defense decision making in response to various attack scenarios. The requirements document provided by the government is the Scope of Work associated with contract DASG6086-C-0036, SW-H-39-85, 28 October 1985. The contractor will develop the requirements specifications associated with each simulation's displays.

3.2 Mission. The BM/C3 Graphical Displays will use the output from the SIMSTAR, TW/AA, or DIDSIM simulations to provide pictorial and tabular threat scenario data. This data will be presented on color monitors and graphic printers for use by decision makers in a strategic defense war room environment. They will also serve as a tool to be used in the conduct of BM/C3 conceptual and architectural analysis.

3.3 Operational Environment. The graphical displays will be developed from a scenario database using data outputs from the SIMSTAR, TW/AA, and DIDSIM simulations. The graphics are to be displayed on the SDC MEGATEK and supporting equipment. Pre- and post-processors will be capable of operating with the existing software and hardware at the SDC Advanced Research Center (ARC). A more detailed description of the SDC ARC hardware and software being used is found in 4.4

3.4 Support Environment. The support environment and the operational environment for this effort are the same.

4. SYSTEM FUNCTIONS AND CHARACTERISTICS.

4.1 System Functions. The BM/C3 Graphical Displays system will display the data and information obtained from one of three computer models which simulate the functions of a strategic defense system. The displays developed will present this information in a manner which can be readily assimilated by decision makers and/or battle managers operating in a strategic defense war room environment. Additionally the displays will aid in the comprehensive evaluation of the concepts being studied with these models. The types of BM/C³ information to be displayed are addressed in the following subparagraphs.

4.1.1 Planning Information.

4.1.1.1 Preplanned Strategies. The task organization and subordinate unit mission assignment that a defense command initiates depends on the enemy threat, friendly assets available, and time available for planning and reaction. Since multiple attack scenarios are possible and the assets available to meet them may change; multiple strategic and tactical responses must be prepared. Adherence to this doctrine will permit a battle manager to reach a rapid decision on which strategy to implement, and will maximize the available reaction and execution time.

4.1.1.2 Rules of Engagement. JCS Pub 1 defines rules of engagement as the positive and procedural management directives issued by competent military authority, which specify the circumstances and limitations under which forces will initiate or continue combat engagement with other encountered forces.

Topics for such rules include: hostile criteria applicable to missile launches; the right of the defense to initiate operations when attacked without approval from higher military or civil authority; the command echelon where positive management of the battle will be conducted; and the criteria governing autonomous operations by different elements of the force. Rules of engagement provide battle managers with the authority to initiate or continue operations with some confidence that their actions are in accordance with national policy or comply with previously defined operational plans.

4.1.1.3 Defense Value Structure. Central to the planning and execution of any defense is the relative value of the assets which are being defended. The initial value structure will affect strategic and tactical plans, with the more valued assets receiving greater protection. Once hostilities are initiated that value structure will change. These changes may be enemy imposed, as in a successful nuclear strike against one target; or they may be self imposed, as in the downgrading of a Strategic Air Command airbase once all aircraft have been launched. Battle managers must be aware of such changes in the asset value structure, since those changes will effect the execution of strategic and tactical plans. Figure 4.1.1.3-1 shows some US military targets of strategic importance.

4.1.1.4 Higher Authority. The initiation of defensive operations will require approval of higher military authority, or of the National Command Authority (NCA). Since the possibility exists that nuclear weapons in some form will comprise part of the defense, Nuclear Release Authorization will be required from

100
 200
 300
 400
 500
 600
 700
 800
 900
 1000
 1100
 1200
 1300
 1400
 1500
 1600
 1700
 1800
 1900
 2000
 2100
 2200
 2300
 2400
 2500
 2600
 2700
 2800
 2900
 3000
 3100
 3200
 3300
 3400
 3500
 3600
 3700
 3800
 3900
 4000
 4100
 4200
 4300
 4400
 4500
 4600
 4700
 4800
 4900
 5000
 5100
 5200
 5300
 5400
 5500
 5600
 5700
 5800
 5900
 6000
 6100
 6200
 6300
 6400
 6500
 6600
 6700
 6800
 6900
 7000
 7100
 7200
 7300
 7400
 7500
 7600
 7700
 7800
 7900
 8000
 8100
 8200
 8300
 8400
 8500
 8600
 8700
 8800
 8900
 9000
 9100
 9200
 9300
 9400
 9500
 9600
 9700
 9800
 9900
 10000

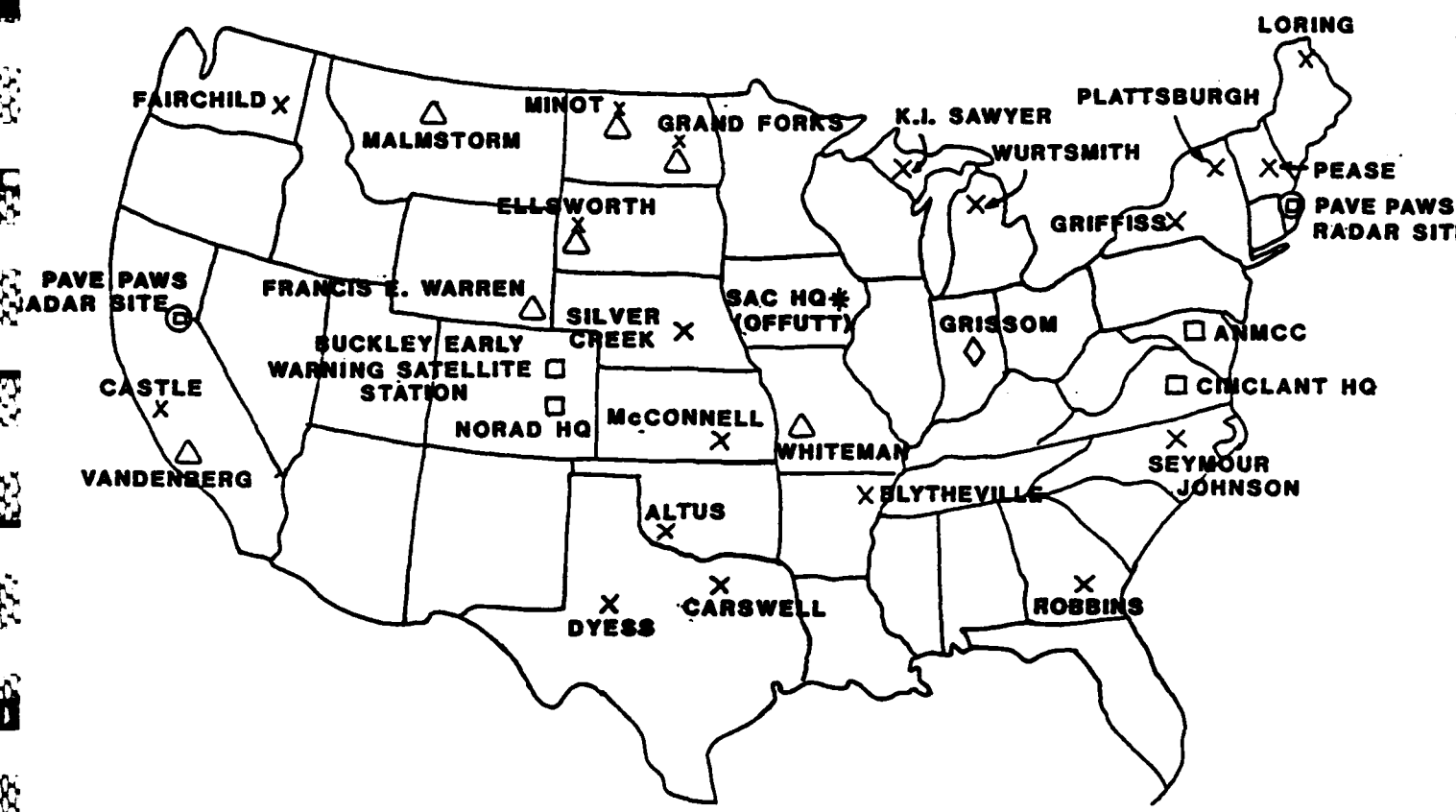

- △ MINUTEMAN COMPLEX
- ⊗ MINUTEMAN COMPLEX AND SAC BOMBER BASE
- × SAC BOMBER BASE
- ◇ NEACP FORWARD BASE
- COMMAND CENTERS

FIGURE 4.1.1.3-1 STRATEGIC MILITARY TARGETS WITHIN CONUS

the NCA. The status of these authorizations must be known to battle managers if their actions are to be in accordance with national policies and strategy. Should failures in the C3 system require it, strategic defense forces must be able to pass such information to strategic offensive forces. Additionally information on which enemy weapons have been expended must be passed to higher authority and offensive forces to permit retargeting for the most effective use of offensive weapons.

4.1.2 Defense System.

4.1.2.1 System Architecture. The system architecture consists of all the nodes and their links within the system. Subsets of the architecture range from a depiction of all the BM/C3 centers; sensors; weapons and weapons platforms; communications nodes; and communications links to the NCA, higher military authority, and lateral and subordinate military organizations within the global system to a depiction of just those elements controlled by a local battle manager.

4.1.2.2 System Status. The operational status of all the nodes within the system are essential to effective decision-making by battle managers. Status information required on BM/C3, communications, sensor, and weapons nodes and platforms includes:

- o State of Alert
- o Committed Capacity
- o Type Equipment (IR, directed energy, other)
- o Operational Status
- o Nodes to Which Connected

4.1.3 Threat Information.

4.1.3.1 Launch Detection. The number and origination location(s) of launches is critical to determining the appropriate response strategy. Such information serves to confirm accidental and peaceful launch situations. It also provides data on probable RV type and yield, and permits early targeting by defense systems. Figure 4.1.3.1-1 shows Soviet ICBM bases with their missile types and missile test centers. This information is extracted from Soviet Military Power, 1986.

4.1.3.2 Fast Burner Identification. A critical element of the SDI concept is the ability to destroy hostile missiles during the boost phase or prior to de-busing. Fast burners are high acceleration boosters. This high acceleration significantly reduces the time between launch and de-bus. A potential use of such weapons is a direct attack on the defense system in order to create safe corridors for following boosters and RVs.

4.1.3.3 Booster Identification. The number, projected trajectory, and type boosters detected are required to allocate defensive fire during the boost phase. High priority targets would be fast burners and heavy missiles because of their potential threat.

4.1.3.4 Booster Payload. Estimates on the number and yields of RVs on each booster assist in target assignment by the local battle manager.

4.1.3.5 RV Identity. Successful battle management requires the numbers, locations, trajectories, and estimated yields of incoming RVs. RV signatures must

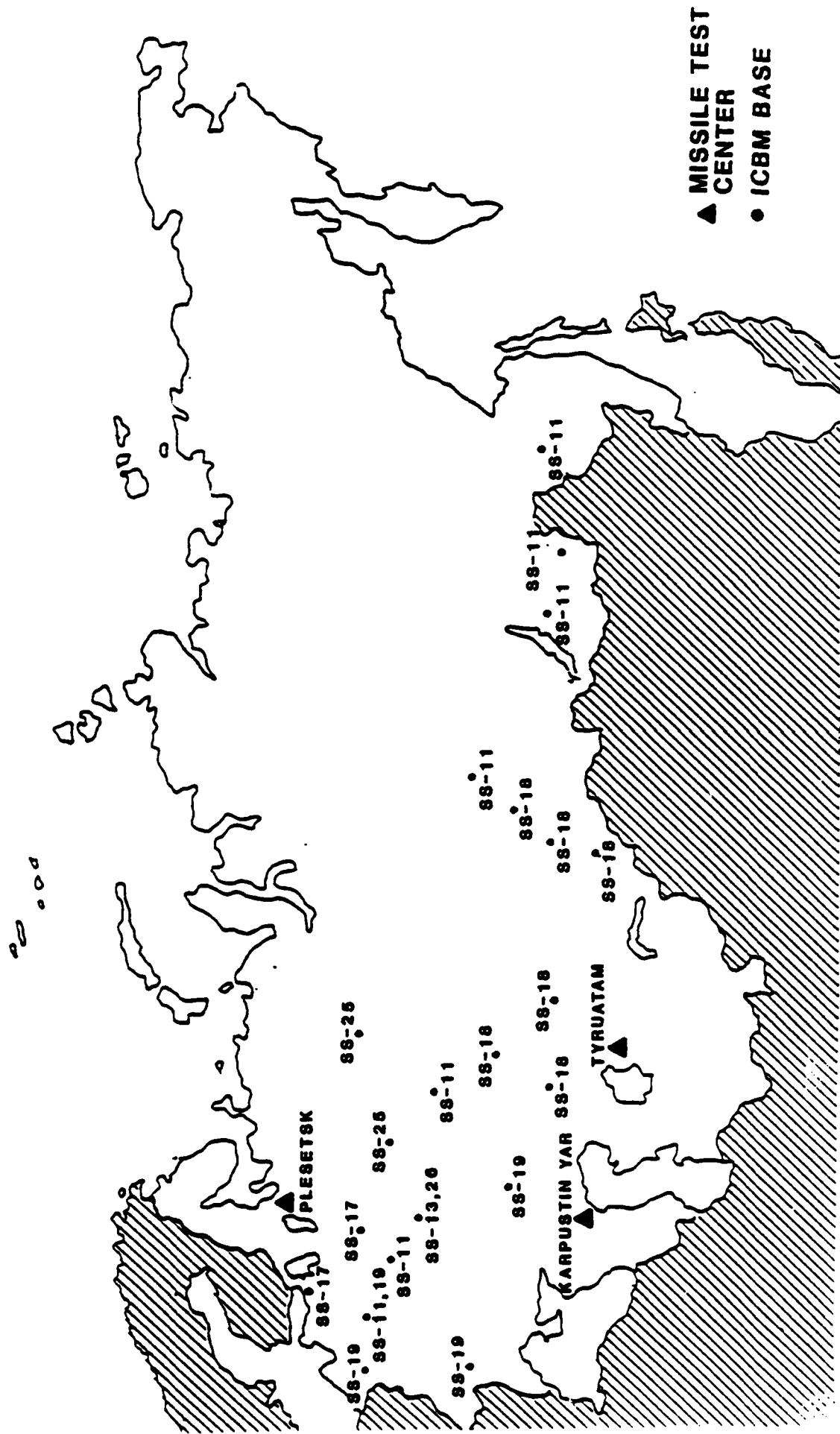

FIGURE 4.1.3.1-1 SOVIET ICBM BASES AND MISSILE TEST CENTERS

be discriminated from those of decoys, debris, and other elements which will begin to clutter space. RV identity information will be used in engagement decisions. Figure 4.1.3.5-1 shows current land based ballistic missile warning sites and their coverages.

4.1.3.6 Impact Location. Projected impact points and footprints of identified RVs identify threatened friendly assets and assist in determining priorities for engaging each RV.

4.1.3.7 Threat Success Rate. The number of RVs targeted against each defended asset must be related to the number of interceptions the defense can accomplish, and the ability of the asset to absorb damage. If the defense system is unable to destroy all incoming RVs, and the defended asset cannot survive the projected damage it will sustain, the defended asset value may have to change. This would be accomplished by a conscious decision to sacrifice an unprotectable asset and commit the freed defensive capability to other assets.

4.1.4 Defense Operations.

4.1.4.1 Information Source Reliability. SATKA and battle management are dependent on sensor supplied information. It is essential that battle managers know the strengths, weaknesses, sensitivity, and reliability of their information sources.

4.1.4.2 Target Assignment. The process of target selection and assignment is initiated at the global level with strategy selection. It filters down through command echelons to individual weapons engaging single boosters and RVs.

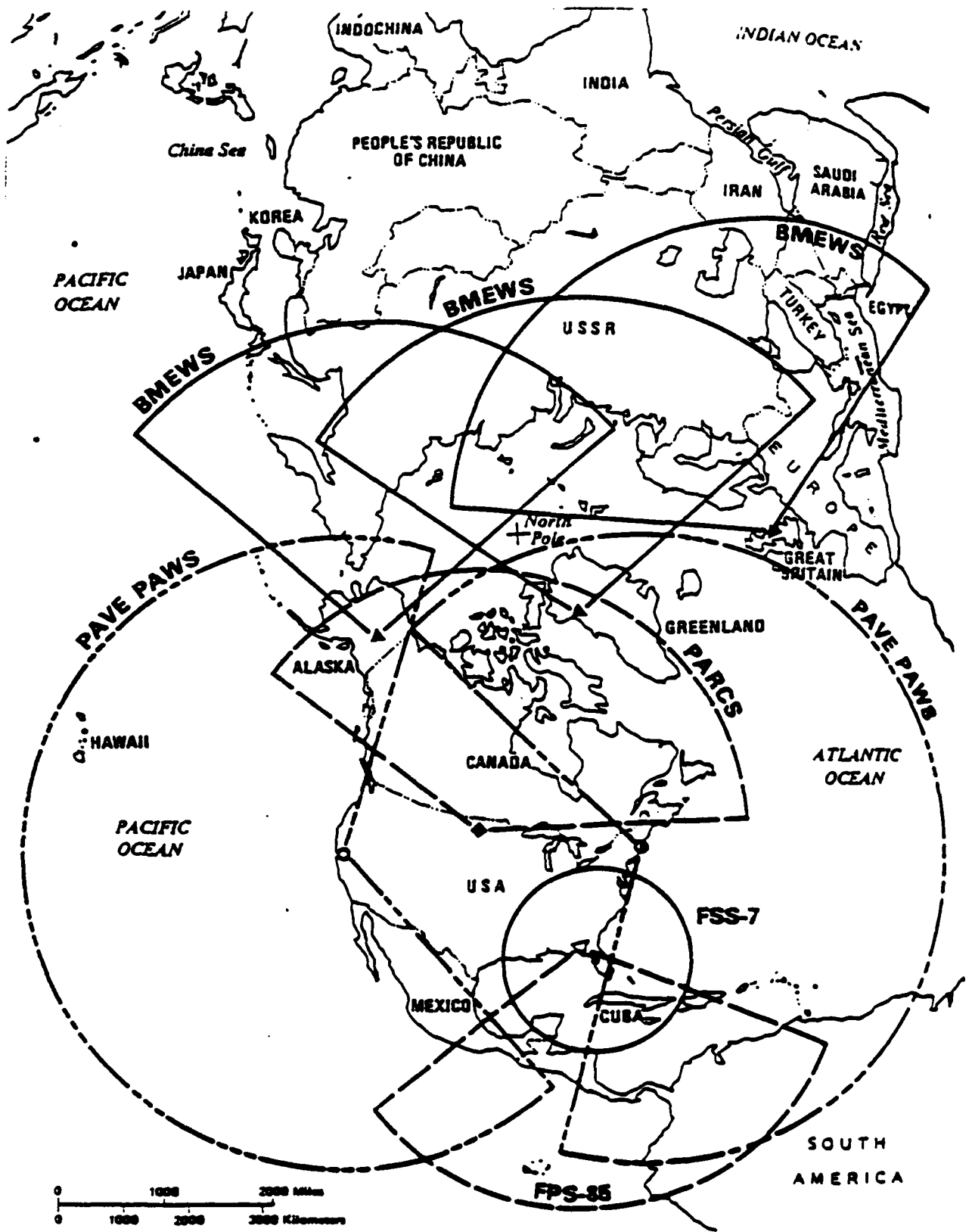

FIGURE 4.1.3.5-1 LAND BASED BALLISTIC MISSILE WARNING SITES AND COVERAGE PATTERNS

4.1.4.3 Engagement Status and Kill Assessments. Battle managers must know which systems are uncommitted, engaging enemy systems, or reaching saturation. They must also know how many of the engagements are successful. This type of information allows changes in defensive strategy and tactics during an extended nuclear exchange.

4.1.4.4 Target Handover. As enemy missiles move from boost to the terminal phase of their course, they will pass through the various tiers of the defense and be passed between battle managers, sensors, and weapons systems. The success of this handover process will, to a large extent, determine whether the battle is won or lost.

4.1.4.5 Saturation. Battle managers must know the ratio of defensive weapon systems to RVs. This will permit the reallocation of assets to fill gaps. In the case of saturation, it will be possible to reach a decision as to which national assets must be sacrificed.

4.2 Computer System Functions. This paragraph describes the operational functions the computer system must perform to generate graphical displays, rather than the battle management functions described in 4.1. Figure 4.2-1 is the proposed system flowchart for the generation of any graphical display.

4.2.1 Data and Information Collection. The BM/C3 graphical displays software will be able to access and use the data and information provided by each of the three simulations. This will be accomplished by modifying the simulations, of necessity, to generate output files containing the appropriate data or information.

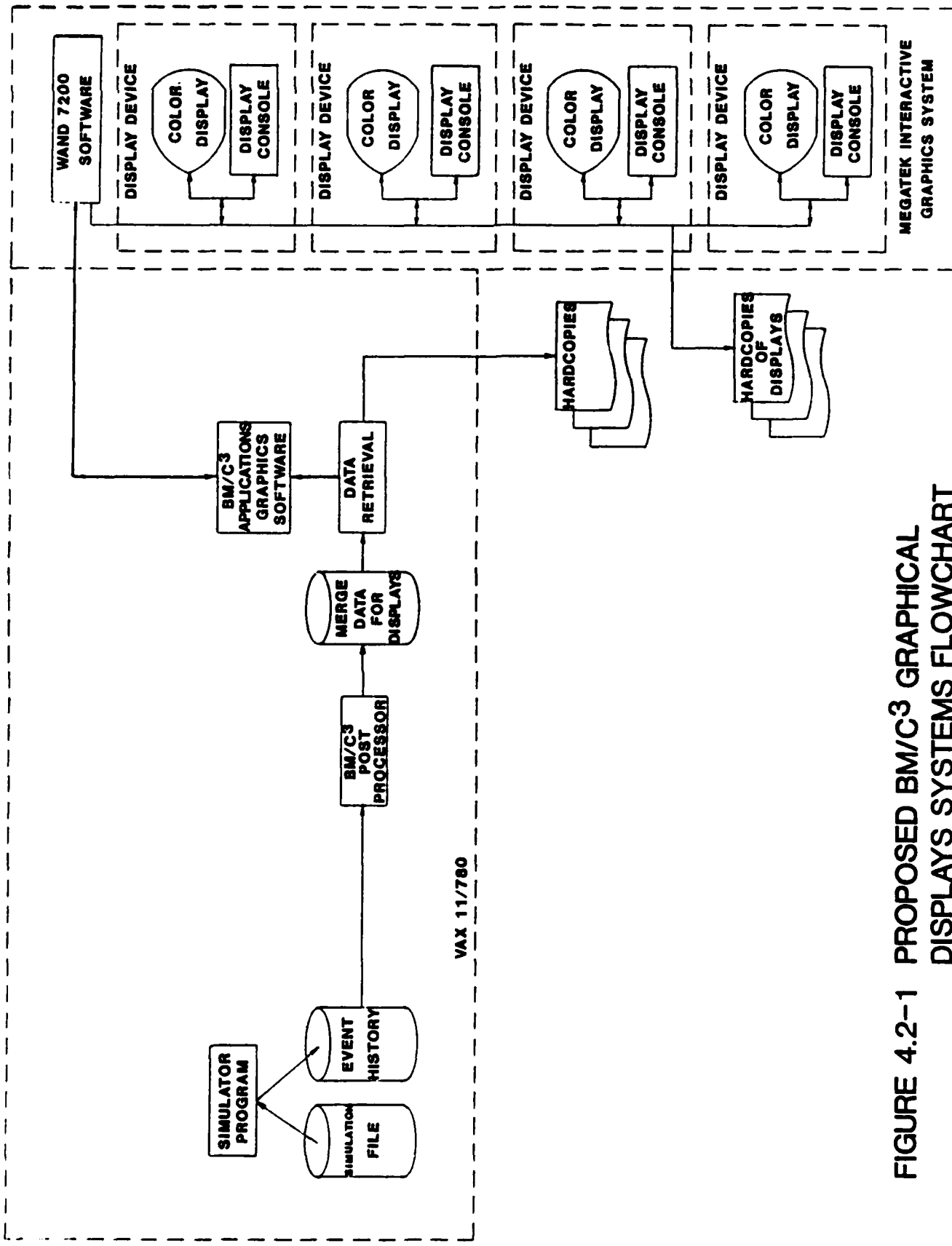

FIGURE 4.2-1 PROPOSED BM/C3 GRAPHICAL DISPLAYS SYSTEMS FLOWCHART

Modification encompasses only the concepts of adapting existing graphical display of outputs; creation of graphical displays for outputs which are currently not displayed; and accessing information available within a simulation which is not currently available as an output. It will not include modification of a simulation to generate information which is not currently available. The graphics software will transform this data to information for display. This COLSA developed software corresponds with the BM/C3 Post-Processor in Figure 4.2-1.

4.2.2 Display Generation. The BM/C3 graphical displays software, the BM/C3 Applications Graphics Software in Fig. 4.2-1, must be capable of formatting the simulation data to generate inputs to the required graphics. Graphical presentations will include tabular, pictorial, graph, and chart formats. Display software must interface with the SDC MEGATEK and supporting equipment. It will be capable of differentiating databases and able to use utility modules to select a particular display for a chosen workstation. Displays will be presented on color monitors and/or graphic printers. Additionally, the display software will function on the VAX 11/780 and MEGATEK systems at the ARC.

4.3 Operator and User Interaction. Interactions described in the following subparagraphs are limited to those between the user and/or operator and the graphics package via the MEGATEK. Should a dynamic, interactive capability be developed in the future, interactions with the simulation will still be via the graphics software and MEGATEK package.

4.3.1 Static Mode. In this mode the user and/or operator will use the graphical display to present data and information derived from a simulation after the simulation has run. The input data will come from the stored results of the simulation. The operator and/or user will be responsible for establishing the scenario and running the simulation to generate a time-tagged display database, or providing access to the results of a previous simulation run. The user selects the software storage media for the display database. The default is disc storage. Once the data display base has been generated, users will have to select the information they wish displayed and the media to be used. This selection will be through the use of menus and of system and environment variables. Displays may be changed at any time.

4.3.2 Dynamic Mode. In the dynamic mode, the user and/or operator selects the desired graphics display before and during the simulation run. The capability to change an entire graphic display is independent of the simulation, but is dependent on the display file structure and the structure of the display database. The display database is updated as the simulation runs, obviating the need for completing a simulation run prior to use of the display package. The ability to operate in a dynamic mode may not be present in the current version of the simulations and no effort will be made to modify them.

4.3.3 Dynamic, Interactive Mode. In this mode, the user and/or operator will be able to input data to the simulation while it is running based on the information being displayed on the monitors and printers. This would permit battle managers with the opportunity to observe the effects of their decisions. The capability to establish this mode does not currently exist due to the nature of

the simulations. Implementation of this mode will require enhancement of the existing simulations and is beyond the scope of the current contract.

4.4 Computer System Characteristics.

4.4.1 Hardware. The ARC Distributed Data Processing test bed consists of Control Data Corporation (CDC), Digital Equipment Corporation (DEC), graphics, special purpose, and prototype equipment. Discussion here will be limited to the DEC VAX 11/780 identified as number 12 (VAX 12) at the ARC and the MEGATEK graphics hardware.

4.4.1.1 DEC Equipment. DEC hardware consists of 13 VAX 11/780s. These are primarily used for experimental projects and for interactive program development and processing. VAX 12 operates independently of the other VAXes and the "cluster" formed by VAX 01-08 and 13. For unclassified operations it may be accessed from any terminal at the ARC or over telephone circuits from elsewhere. Internal operations are at 9600 baud while remote operations are processed through the Infotron Communications Switch at up to 2400 baud. Classified operations must be performed from the secure terminal room. This room houses the four MEGATEK workstations and has cabling for up to six terminals. These terminals are hardwired directly to VAX 12.

4.4.1.2 MEGATEK. The WHIZZARD 7200 graphics system is operational at the ARC. Central to this graphics system is the WHIZZARD 7200 Graphics Engine™ or controller of which there are two in this system. Each controller drives two workstations. There are four MEGATEK workstations at the ARC. Each workstation consists of a color monitor, keyboard, light pen, joystick, and function switches.

the graphics software, and any operating system drivers needed to communicate with the graphics workstation. All graphics output and user input is handled by the interface controller. It can read and write to graphics memory and can communicate to the graphics peripherals. Communications between the host computer and the workstations are carried over a high-speed parallel, DMA interface.

4.4.2 Software. The description of available software will be limited to that which is expected to be used for this program.

4.4.2.1 DEC Standard Software.

4.4.2.1.1 VAX/VMS. This is the general-purpose operating system for VAX systems. It provides an environment for the concurrent execution of multiuser timesharing, batch, and real-time applications written in FORTRAN, BLISS-32, Pascal, and macro-assembly language.

4.4.2.1.2 FORTRAN. The VAX system uses an extended version of FORTRAN 77 and adheres to the ANSI FORTRAN-77 X3.9-1978 Standard.

4.4.2.1.3 PDL. The Process Development Language is a multi-purpose programming language well suited to top-down design. Although not currently installed on VAX 12, it will be installed if requested.

4.4.2.1.4 CONMAN. The CONfiguration MANager is a tool that enables a PDL programmer to compile only the desired procedures in his process. This program is not currently installed on VAX number 12 but will be installed if requested.

4.4.2.2 MEGATEK Software. WAND 7200 is the interactive graphics software package designed by MEGATEK specifically to support the WHIZZARD 7200 family of graphic display systems. It is written in ANSI FORTRAN following SIGGRAPH CORE guidelines, but with some modifications where the guidelines proved inadequate. The features of WAND 7200 include:

- o Device Independence
- o Computer Independence
- o Memory Management
- o Segmentation
- o Transformation Support

The system level of the WAND 7200 contains the device drivers and the computer dependent routines used to tailor it to various computer systems. The software at the ARC is tailored for use on the VAX 11/780. WAND 7200 handles all communications with the WHIZZARD system. It conducts display list management in a way that is transparent to the user and can execute any WHIZZARD 7200 function.

4.4.2.3 BM/C3 Applications Graphics Software. This software consists of various routines written in FORTRAN adhering to the ANSI 78 standard. These routines define the parameters used to establish what will actually be displayed. The routines then call the WAND 7200 package which drives the WHIZZARD 7200 workstations. The applications routines currently available will be expanded by COLSA during the course of this project to provide the required graphical displays.

The applications software will contain an executive unit responsible for controlling the system initialization and database update functions, and the graphic utilities required to build and update the display files. This applications software corresponds with the BM/C3 Applications Graphics Software in Fig. 4.2-1.

These core units provide a common BM/C3 Graphic Display Software System for the three simulations, but one which is developed in increments applicable to each individual simulation. The core elements are described in the following subparagraphs and shown in Fig. 4.4.2.3-1.

4.4.2.3.1 BM/C3 Display Graphics Executive. The executive will be the central element in the BM/C3 Display Graphics Software System. Acting as the controller, it will maintain the interfaces with the MEGATEK keyboard and the VT100, as well as the interface with the simulation output database to update the display databases. The executive also monitors the displays to determine whether the displays are in the initialization mode or update mode.

The executive will maintain a table of flags, control words, or indices. These indicators will be developed in sets which are simulation dependent. Whether a particular set is active will be determined by which simulation is the source of the display database. These indicators will be set during system initialization, and serve as the means of selecting the various displays and display formats for viewing.

4.4.2.3.2 Initialization Unit (IU). This set of modules will initialize the the MEGATEK display files and workstations; refresh memory; and set the control words, flags, and indices that direct the executive bookkeeping function. The

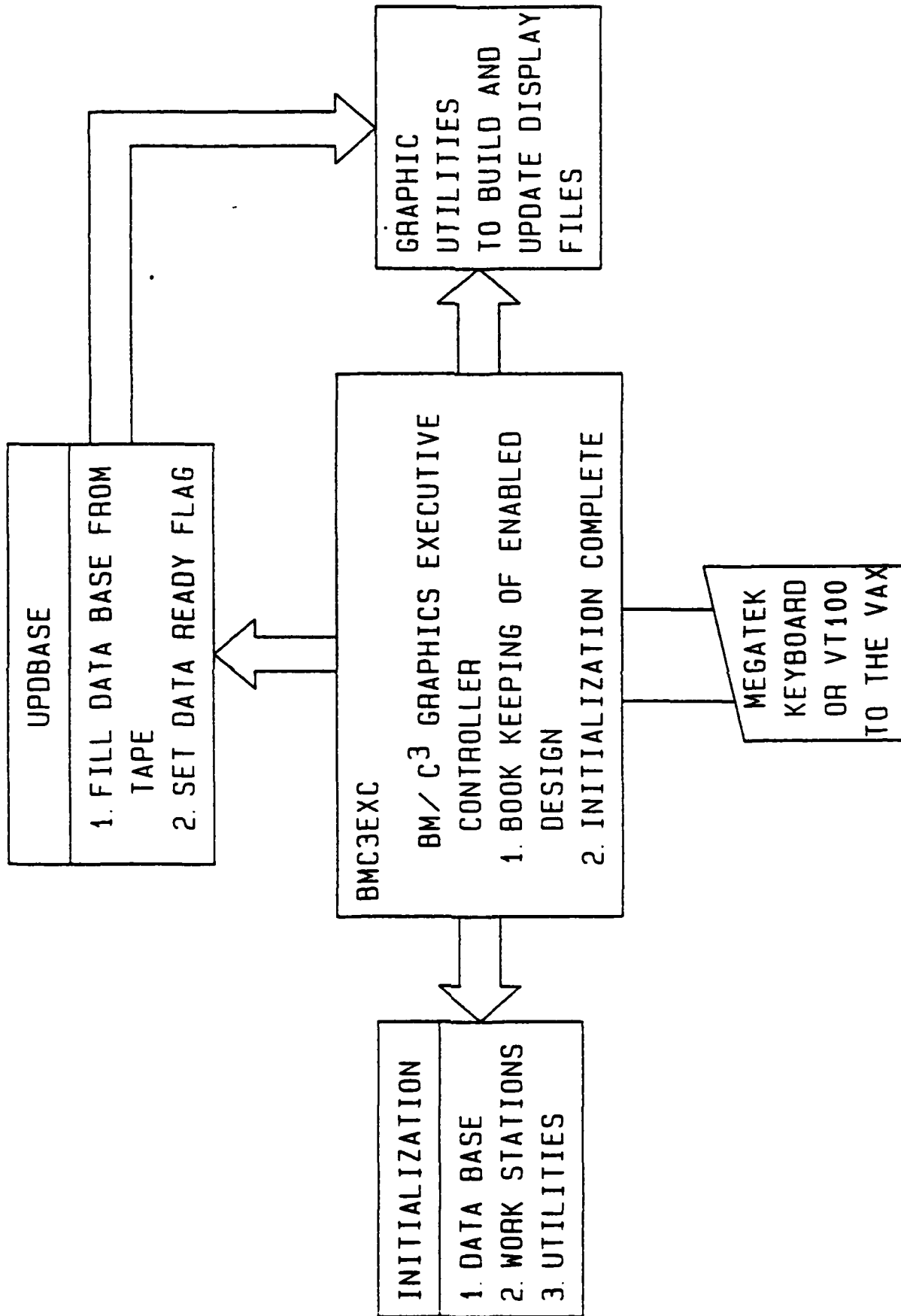

FIGURE 4.4.2.3-1 APPLICATIONS GRAPHICS SOFTWARE FUNCTIONAL DIAGRAM

IU will initialize the display database size and format and activate the desired graphics update modules based on the source simulation.

4.4.2.3.3 Graphic Utilities. This is a set of software modules that establish the core of the display initialization and update software routines. These routines will perform the generic functions of building and updating the display files and will not be specific to any simulation data base.

5. GOVERNMENT AGENCIES. The US Army Strategic Defense Command and its subordinate elements are currently the only identified development, support, or user agencies of this system. However, it is possible that other agencies operating under the aegis of the Strategic Defense Initiative Organization may make use of the graphical displays.

6. NOTES

6.1 Classified Material Disclaimer

No classified information was used in the preparation of this document and all figures were derived from unclassified material.

6.2 Acronyms and Abbreviations

| | |
|----------|---|
| ANMCC | Alternate National Military Command Center |
| ANSI | American National Standard Institute |
| ARC | Advanced Research Center |
| ARCSTAT | Advanced Research Center Status |
| BM | Battle Manager (-ment) |
| BM/C3 | Battle Management/Command, Control and Communications |
| BMD | Ballistic Missile Defense |
| BMEWS | Ballistic Missile Early Warning System |
| C3 | Command, Control and Communications |
| CONUS | Continental United States |
| CDC | Control Data Corporation |
| CINCLANT | Commander-in-Chief Atlantic |
| CONMAN | Configuration Manager |
| DEC | Digital Equipment Corporation |
| DIDSIM | Defense-In-Depth Simulation |
| FPS-85 | A type early warning radar |
| FSS-7 | A type early warning radar |
| HQ | Headquarters |
| IR | Infrared |

END

Dtjic

7-86