

AD-R168 250

INHALATION TOXICOLOGY VI EVALUATION OF THE RELATIVE
TOXICITY OF THERMAL D. (U) FEDERAL AVIATION
ADMINISTRATION WASHINGTON DC OFFICE OF AVIAT

1/1

UNCLASSIFIED

C R CRANE ET AL. FEB 86 DOT/FAR/AM-86/3

F/G 6/20

NL



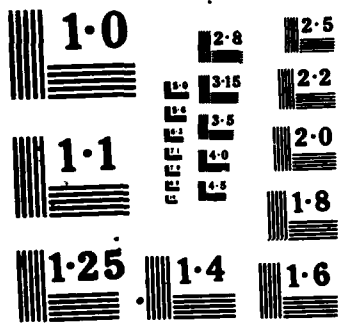

NATIONAL BUREAU OF S
MICROCOPY RESOLUTION TEST

DOT/FAA/AM-86/3

Office of Aviation Medicine
Washington, D.C. 20591

INHALATION TOXICOLOGY: VI. Evaluation of the Relative Toxicity of Thermal Decomposition Products from Nine Aircraft Panel Materials

Charles R. Crane
Donald C. Sanders
Boyd R. Endecott
John K. Abbott

Civil Aeromedical Institute
Federal Aviation Administration
Oklahoma City, Oklahoma 73125

February 1986

Final Report

This document is available to the public
through the National Technical Information
Service, Springfield, Virginia 22161



U.S. Department of Transportation
Federal Aviation Administration

NOTICE

This document is disseminated under the sponsorship of the Department of Transportation in the interest of information exchange. The United States Government assumes no liability for its contents or use thereof.

The animals used for this experiment were lawfully acquired and treated in accordance with the "Guide for the Care and Use of Laboratory Animal Resources," National Research Council, DHEW Publication No. (NIH) 74-23.

1. Report No. DOT/FAA/AM-86/3		2. Government Accession No. ADA 168250		3. Recipient's Catalog No.	
4. Title and Subtitle INHALATION TOXICOLOGY: VI. EVALUATION OF THE RELATIVE TOXICITY OF THERMAL DECOMPOSITION PRODUCTS FROM NINE AIRCRAFT PANEL MATERIALS				5. Report Date February 1986	
				6. Performing Organization Code	
7. Author(s) C.R. Crane, D.C. Sanders, B.R. Endecott, and J.K. Abbott				8. Performing Organization Report No. DOT/FAA/AM-86/3	
9. Performing Organization Name and Address Federal Aviation Administration Civil Aeromedical Institute Oklahoma City, Oklahoma 73125				10. Work Unit No. (TRAIS)	
				11. Contract or Grant No.	
12. Sponsoring Agency Name and Address Office of Aviation Medicine Federal Aviation Administration 800 Independence Avenue, S.W. Washington, D.C. 20591				13. Type of Report and Period Covered	
				14. Sponsoring Agency Code	
15. Supplementary Notes					
16. Abstract <p>The purpose of this study was to determine the relative toxicity of the combustion products from nine aircraft cabin panels, representing both composite and homogeneous construction, that were being tested concurrently for flammability and smoke production at the FAA Technical Center. We designed and constructed a combustion/exposure assembly in which panel sections were pyrolyzed by radiant head directed onto the upper surface only; the relative toxicity of the evolved gases was measured by determining the effect (time-to-incapacitation) on the laboratory rat. We also determined the relative toxicity of gases from the same nine panels when pyrolyzed in the older (and smaller) combustion tube assembly in order to compare the effects of the different pyrolysis modes. <i>Keywords:</i></p>					
17. Key Words Combustion Toxicity Time-to-incapacitation (t_i) Time-to death (t_d) Heat flux level Pyrolysis condition Internal Aircraft Panel				18. Distribution Statement Document is available to the public through the National Technical Information Service, Springfield, Virginia 22161	
19. Security Classif. (of this report) Unclassified		20. Security Classif. (of this page) Unclassified		21. No. of Pages 15	22. Price

INHALATION TOXICOLOGY: VI. EVALUATION OF THE RELATIVE
TOXICITY OF THERMAL DECOMPOSITION PRODUCTS FROM
AIRCRAFT PANEL MATERIALS

INTRODUCTION

Modern aircraft interior panels have proven remarkably resistant to small ignition sources; indeed, all are required by Federal Aviation Regulation (FAR) 25.853(a) to be self-extinguishing when the ignition source is removed (1). They are self-extinguishing because more heat is required to evolve sufficient flammable gases than the burning material can provide without an external source of heat. Panels can and do burn, however, when subjected to a sustained heat flux from other burning cabin materials; therefore, the potential toxic hazard from evolved gases should also be considered when panels are selected for use in the closed environment of an aircraft cabin.

In the laboratory, we have observed that the toxicity of pyrolysis products from aircraft cabin materials can vary markedly between flaming and nonflaming conditions and, to a lesser extent, can vary with pyrolysis temperature. Our previous studies utilized a combustion tube assembly completely encircled by a small annular furnace that provided radiant heat around the perimeter of the tube and conductive heat through the sample boat (2,3). However, this omnidirectional heat flux may not accurately reflect the conditions to which panels (and other flat surfaces) are likely to be exposed in an actual fire. Whether the source of the heat is from an external fuel fire heating the rear surface of the panel or from burning interior materials radiating heat onto the panel facing, the source (at least initially) is likely to be unidirectional. Under these conditions, the multilayer construction of many modern panels would cause the evolved gas composition (and thus toxicity) to vary as successive layers are pyrolyzed. Logically, the measured toxicity of the evolved gases from such composite panels would be more relevant if the pyrolysis mode more nearly reflected a probable real fire condition.

The purpose of this study was to determine the relative toxicity of the combustion products from nine aircraft cabin panels, representing both composite and homogeneous construction, that were being tested concurrently for flammability and smoke production at the FAA Technical Center (4,5). We designed and constructed a combustion/exposure assembly in which panel sections were pyrolyzed by radiant heat directed onto the upper surface only; the relative toxicity of the evolved gases was measured by determining the effect (time-to-incapacitation) on the laboratory rat. We also determined the relative toxicity of gases from the same nine panels when pyrolyzed in the older (and smaller) combustion tube assembly in order to compare the effects of the different pyrolysis modes.

Sample equivalency between the two systems was based on equal sample surface-area-to-volume ratios instead of the more familiar equal weight-to-volume ratios, a modification based on the principle that equal surface areas of all panels would be utilized in their final end-use application.

1.



Dist	Avail and Special
A-1	

MATERIALS

Animals. Male albino rats of Sprague-Dawley origin were obtained from Charles River Breeding Laboratories, Wilmington, MA. They were ordered in a weight range of 100 to 120 g and were held in isolation for 8 days prior to use. All animals were inspected by a veterinarian on arrival and were maintained on drinking water containing 1.5 g/L of sulfathiazole for the first 4 days, then normal tap water for the remaining 4 days of isolation; food and water were available continuously.

Rats were fasted overnight before testing to establish an equivalent metabolic state; each animal was weighed and marked with an identifying color code just prior to use.

Test Materials. Nine panels were received from the FAA Technical Center in Atlantic City, NJ, for toxicity testing. The numbering system and panel descriptions below were furnished by the Technical Center; panels 1 through 5 are identical to the same numbered panels described in their improved flammability method tests (5). This numbering system is also used throughout this report.

Panel No. 1	Epoxy/Fiberglas honeycomb
Panel No. 2	Phenolic/Fiberglas honeycomb
Panel No. 3	Epoxy/Kevlar honeycomb
Panel No. 4	Phenolic/Kevlar honeycomb
Panel No. 5	Phenolic/Graphite honeycomb
Panel No. 6	Polyether-ether-ketone/Polyimide/Fiberglas honeycomb
Panel No. 7	Acrylonitrile-butadiene-styrene/Polyvinylchloride thermoplastic sheet
Panel No. 8	Polycarbonate thermoplastic sheet
Panel No. 9	Polyetherimide thermoplastic sheet

Combustion/Exposure Assemblies. Two animal exposure systems were used in this study. The larger system (265 L) was equipped with a radiant heat unit designed to deliver heat to one side of the sample only. The smaller system (12.6 L) was equipped with a 2-inch combustion tube, enclosed by a cylindrical heating unit that provided radiant heat around the perimeter of the tube and conductive heat through a quartz combustion boat in contact with the tube wall.

265-L System. The animal chamber, shown in Figure 1, was constructed from polymethylmethacrylate (PMMA) and has an internal volume of 203 L. A smaller 42-L plenum, constructed from polycarbonate for heat resistance, was positioned at one end and over the combustion assembly to allow cooling and dilution of the hot gases. The cooled gases entered the animal chamber through two 7-cm-diameter PMMA tubes. A flexible tube between the floor of the exposure chamber and the bottom of the combustion assembly provided continuous recirculation of the animal chamber air underneath and around the test sample, into the polycarbonate plenum, and back into the animal chamber. The experimental animals were contained in four 20-cm-diameter rotary cages mounted on a motor-driven shaft inside the animal chamber. Perimeter speed for the rotary cages (and required walking speed for the rats) was 6.4 cm/s.

The combustion assembly was constructed from stainless steel with a triangular cross section; full-length quartz windows in the sides of the assembly allowed radiant heat from four 2,000-watt quartz lamps (two on each side) to impinge on the sample surface at approximately 45° angles. A hot-wire igniter was suspended approximately 1 cm above the sample position to ignite the evolved gases when flaming combustion was desired. The total system volume was 265 L, and the maximum test sample size was 7.6 by 22.9 cm (3 by 9 in).

12.6-L System. The construction of this system has been described in detail in previous publications (2,3), and a diagram of the specific configuration used in this study is shown in Figure 2. Briefly, the animal chamber consisted of a PMMA box containing a motor-driven rotating cage with compartments for three rats; perimeter speed for this cage was also 6.4 cm/s. A recirculating blower forced chamber air through the combustion tube, over the sample, and (mixed with the combustion gases) back into the animal chamber. Heat was applied to the test sample by a pair of 425-watt, semicylindrical heating units encircling the combustion tube; the total system volume was 12.6 L. A hot wire igniter was similarly available, if flaming combustion was desired.

Analytical and Support Systems. Similar gas analysis systems were used for both chambers. The chamber atmosphere was continuously pumped through the sample loops of two gas chromatographs and back into the chamber, using a ceramic piston pump with Saran tubing connections. One gas chromatograph (with a thermistor detector) analyzed for carbon monoxide (CO) and oxygen (O₂); the other gas chromatograph (with a nitrogen-phosphorus detector) analyzed for hydrogen cyanide (HCN). Samples were analyzed at 1.8-min intervals for CO and O₂ and at 3.6-min intervals for HCN.

Oxygen was resupplied manually to the animal chamber when the concentration dropped below the normal ambient level. During flaming combustion, oxygen was added continuously while the sample was flaming; during nonflaming tests and post-burn observation periods, a lesser rate of addition was sufficient to maintain the chamber concentration between 90 percent and 100 percent of the ambient level. Temperatures were monitored throughout the test period from thermocouples mounted in the animal chambers and in the combustion tube assembly.

TEST PROCEDURE

For tests in the 265-L system, a fasted and weighed albino rat was placed in each of the four rotating cages. The animal chamber, which consists of a 203-L polymethylmethacrylate (PMMA) box, was fitted over the rotating cages and sealed against a gasket embedded in the chamber base. The adjoining mixing/cooling chamber (or plenum) was then connected to the animal chamber by two PMMA tubes as shown in Figure 1. A 7.6- by 22.9-cm section of panel, conditioned overnight at 50 percent relative humidity, was weighed and placed in a combustion boat. The chamber was sealed; the oxygen resupply, gas sampling, and temperature monitoring equipment were connected; and the power control for the radiant heat assembly was set to supply the desired incident flux level. At zero time, the cage rotation motor, heater power supply, recirculating fans, timer, and (when used) the hot wire igniter were activated

simultaneously. The test sample was observed for the first indication of decomposition (melting, smoke) and for ignition. Sampling (and analysis) of the chamber atmosphere began 1 min after initiation of the test. Oxygen was resupplied manually when the chromatographic analysis indicated a decrease below the ambient concentration. Time-to-incapacitation (t_i) was noted when each rat could no longer perform the coordinated act of walking in the rotating cage (i.e., when sliding or tumbling began). When all rats were incapacitated, cage rotation was stopped. Time-to-death (t_d) was recorded when visible signs of respiration had ceased. Power to the radiant heat lamps was shut off at 10 min to prevent overheating the air in the exposure chamber. Animal observations were limited to the 30-min test period.

Tests in the small chamber (12.6 L) were performed in the same manner except for sample size and method of sample insertion. Since the cylindrical heating unit required several minutes to reach a stable temperature, the system was preheated to the desired temperature before inserting the sample. The test sample was placed in a quartz combustion boat and, at time zero, was inserted into the center of the heated area in the combustion tube.

Two test conditions were selected for each system. One test was performed at a low temperature (600 °C in the 12.6-L system) or low incident flux (5 W/cm² in the 265-L system) that would allow sample decomposition without spontaneous ignition (i.e., a nonflaming mode). The other condition utilized a higher temperature (750 °C in the 12.6-L system) combined with hot wire ignition of the evolved gases to insure flaming combustion. In the flaming test condition, the hot wire igniter was activated at initiation of the test and deactivated immediately after sample ignition.

Each panel was tested twice under each of the four pyrolysis conditions. Three rats per test were exposed in the 12.6-L combustion tube assembly for a total of six rats exposed at each temperature. The 265-L radiant heat assembly accommodated four rats per test, allowing the exposure of eight rats at each heat flux level.

At the end of each test, the sample residue was removed, cooled to room temperature, and weighed to determine the weight percent lost in each pyrolysis condition. Since most of the panels contained noncombustible (or extremely heat-resistant) materials, we pyrolyzed weighed sections of each at 850 °C for 3.3 h to determine what fraction of the total weight was potentially combustible. This provided a standard for comparison of combustion efficiency for each system and condition. The percent of sample weight lost during pyrolysis (Table 2) was based on this weight of combustible material in the sample, not the total sample weight.

The maximum sample size accommodated by the combustion boat in the 265-L system was 7.6 by 22.9 cm, and this size was selected for the initial panel tests. To obtain an equivalent area-to-volume ratio for the 12.6-L system, the surface area of the larger sample (174 cm²) was multiplied by the ratio of the relative chamber volumes. Squares of each panel, with sides 2.9 cm long, were cut to provide the calculated 8.3-cm² equivalent surface area for the 12.6-L system.

RESULTS AND DISCUSSION

It is evident from the data in Table 1 that only tests at the higher temperature (or higher heat flux) produced measurable animal responses from all nine panels during the 30-min observation period. Under less severe conditions, gases from some of the panels failed to incapacitate all the test animals. It is equally evident from the weight loss data (Table 2) that a probable reason for some failures to incapacitate was that the more heat-resistant panels simply did not decompose sufficiently at the lower temperatures. At 600 °C in the 12.6-L system, panels 6, 9, and 5 lost 12 percent, 20 percent, and 28 percent of their respective combustible weights. Only slightly greater decomposition was noted for these panels in the 265-L radiant heat system at the 5-W/cm² level.

At the higher temperature (and higher heat flux level), all panels decomposed to a greater extent. At 750 °C (flaming) in the 12.6-L system, all but two of the panels lost 99 percent to 100 percent of their combustible weight. The exceptions were panel No. 5, with a phenolic/graphite honeycomb construction, which lost approximately 90 percent, and panel No. 9, a homogeneous polyetherimide, which lost about 72 percent. In the 265-L radiant heat assembly at 7.5 W/cm², panels 5 and 9 lost 51 percent and 54 percent respectively, while the remainder of the panels lost 75 percent to 97 percent of their total combustible weight.

Panel rankings by animal response (t_i) were not identical for any two of the four pyrolysis conditions. Within each condition, some of the mean response times differed only slightly and statistical analysis indicated no significant difference between them (t-test, P₀₅ level)(6). Figure 3 depicts the ranking of panels by mean t_i 's with those producing statistically like responses grouped together.

We have previously considered that polymeric materials should be ranked for the toxicity of their combustion products by selecting the "worst case" condition (the test condition that produced the shortest t_i) for each material, then ranking the materials from most toxic (shortest t_i) to least toxic (longest t_i). In this series of tests, the shortest t_i 's were those produced at 750 °C (flaming) in the 12.6-L system. In the 265-L radiant heat system, the shortest t_i 's were produced at the 7.5-W/cm² (flaming) flux level. No "worst case" response was noted at the lower temperature (or lower heat flux) condition in either system. Therefore, the "worst case" ranking for the nine panels is depicted in Table 1, column 2, with all t_i 's selected from the 750 °C (flaming) condition in the 12.6-L combustion tube assembly.

Some test performance characteristics of the panels can be described best on an individual basis. A summary of characteristics noted during the toxicity testing follows.

Panel No. 1, Epoxy/Fiberglas Honeycomb. This panel consistently produced t_i 's in the more toxic 15 percent of each t_i range under all four test conditions. Smoke production was rapid, but of medium density. Peak CO

production was 10,641 ppm and peak HCN was 340 ppm; both peak levels were recorded in the 750 °C (flaming) tests in the 12.6-L chamber. The panel contained 42 percent by weight of noncombustible material (at 850 °C for 3.3 h).

Panel No. 2, Phenolic/Fiberglas Honeycomb. This panel exhibited variable toxicity with the different test conditions; it produced t_i 's in the more toxic 15 percent of each range at 600 °C (12.6 L) and 5 W/cm² (265 L) but fell into the mid- to low-toxicity ranges at the higher temperatures. Peak HCN (201 ppm) and CO (10,878 ppm) values were both recorded at 600 °C in the 12.6-L assembly. Visible smoke production was of low to medium density. Noncombustible material comprised 51 percent of the total weight of this panel.

Panel No. 3, Epoxy/Kevlar Honeycomb. In all four test conditions, panel No. 3 produced t_i 's in the most toxic 5 percent of each t_i range. Very dense smoke was produced, particularly at the higher temperatures. Peak HCN was 600 ppm (7.5 W/cm², 265-L system) and peak CO was 9,105 ppm (600 °C, 12.6-L system). Noncombustible material was less than 3 percent of the total panel weight.

Panel No. 4, Phenolic/Kevlar Honeycomb. This panel produced t_i 's in the more toxic 20 percent of each t_i range for all four test conditions. Very dense smoke was produced at the higher temperatures but cleared rapidly after heating ceased. Peak HCN was 534 ppm (at 5 W/cm²) and peak CO was 9,398 ppm (at 7.5 W/cm²), both in the 265-L system. Approximately 3 percent of the panel weight was noncombustible material.

Panel No. 5, Phenolic/Graphite Honeycomb. Under all test conditions, the t_i 's for panel No. 5 were found to be near the middle of each range. Smoke density was minimal, and production of CO and HCN was moderate. Maximum CO (6,832 ppm) was detected at 750 °C in the 12.6-L system and maximum HCN (250 ppm) was 5 W/cm² in the 265-L system. Less than 2 percent of the sample weight was noncombustible material.

Panel No. 6, Polyether-ether-ketone/Polyimide/Fiberglas Honeycomb. Animal responses to this heat-resistant panel varied with the test temperatures; t_i 's were in the more toxic 20 percent of each range at the higher temperatures (750 °C and 7.5 W/cm²), were midrange at 5 W/cm², and, at 600 °C (12.6-L system), none of the animals were incapacitated. Very little visible smoke was produced at any test temperature. Peak CO concentration was 14,249 ppm, and peak HCN was 537 ppm; both peak values were recorded at 750 °C in the 12.6-L combustion tube assembly. Approximately 57 percent of the panel was noncombustible material.

Panel No. 7, Acrylonitrile-butadiene-styrene/Polyvinylchloride. Animal response times for this panel were in the more toxic 25 percent of each range at 5.0 and 7.5 W/cm² (265-L system) and at 750 °C (12.6-L system). At 600 °C (12.6-L system), none of the animals were incapacitated during the observation period. This panel produced very dense, white smoke under all test conditions; smoke density was of sufficient magnitude to make animal observation difficult. The maximum CO (11,132 ppm) and HCN (749 ppm) concentrations were both recorded in the 265-L radiant heat system at the 7.5-W/cm² flux level. Noncombustible material was less than 4 percent.

Delayed autoignition of the combustion gases occurred twice during the testing of panel No. 7 at 5 W/cm^2 in the 265-L radiant heat assembly. The resulting "soft" explosions were confined to the polycarbonate mixing/cooling chamber, and the overpressure was relieved by the opening of the blowout panel (the top cover of the polycarbonate plenum). The white smoke cleared quickly after ignition occurred, and heavy soot deposits rapidly covered the interior chamber walls. No damage to the chamber resulted.

Panel No. 8, Polycarbonate Thermoplastic Sheet. At the higher temperatures, the polycarbonate sheet produced t_i 's in midrange; lower temperatures produced longer t_i 's near the bottom of the respective ranges. Relatively dense smoke was produced under all test conditions, with the smoke density reaching its peak more rapidly at the higher temperatures. The maximum CO concentration (15,188 ppm) was detected at 750°C in the 12.6-L system; no measurable HCN was produced under any of the test conditions. Noncombustible material was less than 2 percent.

Panel No. 9, Polyetherimide Thermoplastic Sheet. This material was the least toxic of all nine panels under all test conditions. Moderate to heavy white smoke was produced, usually developing late in the test (6 to 7 min) at the lower temperatures. Peak CO concentration (3,843 ppm) was detected in the 265-L system at 7.5 W/cm^2 . A peak HCN concentration of 133 ppm was recorded at 750°C in the 12.6-L system, but no measurable HCN was detected under any of the other test conditions. This panel contained about 21 percent noncombustible material, but less than 75 percent of the remaining combustible content was pyrolyzed by the most severe pyrolysis condition (750°C , 12.6-L combustion tube system).

SUMMARY AND CONCLUSIONS

We have described the testing of nine aircraft panels for the relative toxicity of their gaseous combustion products in two different laboratory-scale combustion/exposure systems and under flaming and nonflaming conditions. One system was designed to thermally decompose the flat panel samples by radiant heat impinging on the upper surface only; the second system decomposed samples by a combination of conductive and omnidirectional radiant heat inside a quartz combustion tube. Time-to-incapacitation in the laboratory rat was the response used to compare the toxicity of the panel combustion gases; relative toxicity within each system was based on the animal responses observed when equal surface areas of each panel were pyrolyzed. Sample surface areas proportional to the respective system volumes were used for comparisons between the two combustion/exposure systems.

Only the higher temperatures in both the radiant heat and the combustion tube systems proved suitable for toxicological differentiation between the panels. Lower temperatures (and heat flux levels) failed to pyrolyze some of the more heat-resistant panels to the extent that would reliably produce an animal response within the observation period.

The "worst case" condition for all panels (the test condition that produced the shortest t_i 's) across all conditions was the 750 °C flaming test in the 12.6-L combustion tube assembly. Times-to-incapacitation for this condition were not widely separated but fell into approximately the three groups shown below.

(Most toxic)	Panels 1, 3, 4, 6, 7	(t_i 's: 3.3 to 4.1 min)
(Midrange)	Panels 5, 8	(t_i 's: 6.1 min for both)
(Least toxic)	Panels 2, 9	(t_i 's: 7.3 and 9.1 min)

A similar panel grouping is shown below for the animal response times recorded in the 265-L radiant heat assembly; all of the shortest response times (for this system) occurred during the 7.5-W/cm² tests.

(Most toxic)	Panels 1, 3, 4, 7	(t_i 's: 7.3 to 8.3 min)
(Midrange)	Panels 2, 6, 8	(t_i 's: 9.3 to 10.0 min)
(Least toxic)	Panels 5, 9	(t_i 's: 12.4 and 17.7 min)

As indicated above (and in Table 1), the higher temperature in each system produced similar, but not identical, potential toxicity rankings for the nine panels. The combustion tube assembly produced shorter t_i 's and equal or higher peak CO and HCN concentrations than did the radiant heat furnace. The combustion tube also produced a more rapid development of the peak gas concentrations from the thicker panels with the honeycomb type of construction; little or no such effect was observed with the thinner, homogeneous thermoplastic sheets (panels 7, 8, and 9).

All panels, except the polycarbonate sheet (panel No. 8) produced HCN under the "worst case" condition (750 °C, flaming). Under the same condition, all panels produced lethal peak concentrations of CO, with the highest (from panels 1, 6, and 8) exceeding 10,000 ppm. Except for these three panels, peak CO concentrations were similar at the high temperature conditions in both combustion systems.

At the high temperature conditions (750 °C and 7.5 W/cm²), which are near the practical upper limits for both combustion systems, sample decomposition (at 10 min) was more nearly complete in the combustion tube furnace than in the radiant heat assembly (Table 2). This higher combustion efficiency exists even though the radiant heat flux, measured inside the combustion tube at 750 °C, is less (5.2 to 5.4 W/cm²) than the corresponding unidirectional flux (7.5 W/cm²) in the radiant heat furnace. This increased rate of decomposition in the combustion tube appears to be due to the omnidirectional nature of the heat flux, which does not allow one side of the sample to insulate the other, and possibly to the added heat input

supplied by conduction. However, despite the somewhat lesser efficiency of the radiant furnace, some investigators feel that this combustion method may more closely approximate the conditions to which panels (and other flat surfaces) are exposed in a real cabin fire and may, therefore, produce a more realistic measure of relative potential toxicity for this particular class of materials.

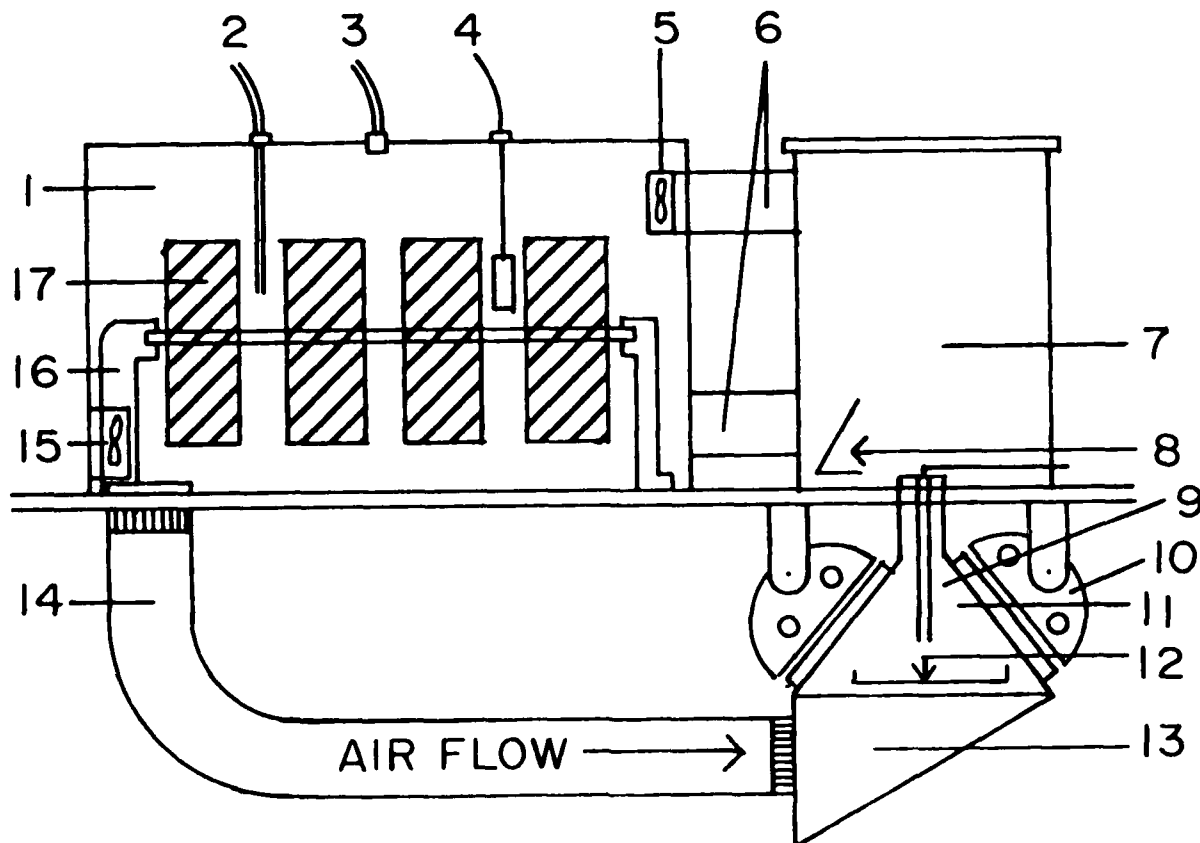

FIGURE 1. COMBUSTION/EXPOSURE ASSEMBLY (265 L)

1. Animal exposure chamber
2. Gas sampling inlet
3. Oxygen inlet
4. Thermocouple (air temperature)
5. Muffin fan (recirculation assembly); Rotron Manufacturing Company, Woodstock, NY
6. Chamber connecting tubes
7. Mixing/cooling chamber
8. Gas deflector
9. Hot wire igniter
10. Heat lamp reflector with two 2,000-watt General Electric quartz lamps (GE QH2M/T3/CL/HT 240 V)
11. Sample combustion chamber
12. Sample combustion boat (stainless steel, for 7.6- by 22.9-cm sample)
13. Combustion chamber air plenum
14. Flexible tube, 10-cm-diameter (to supply air to the sample combustion chamber)
15. Muffin fan (for mixing chamber air)
16. Cage motor drive shaft and axle support
17. Individual rotating cage

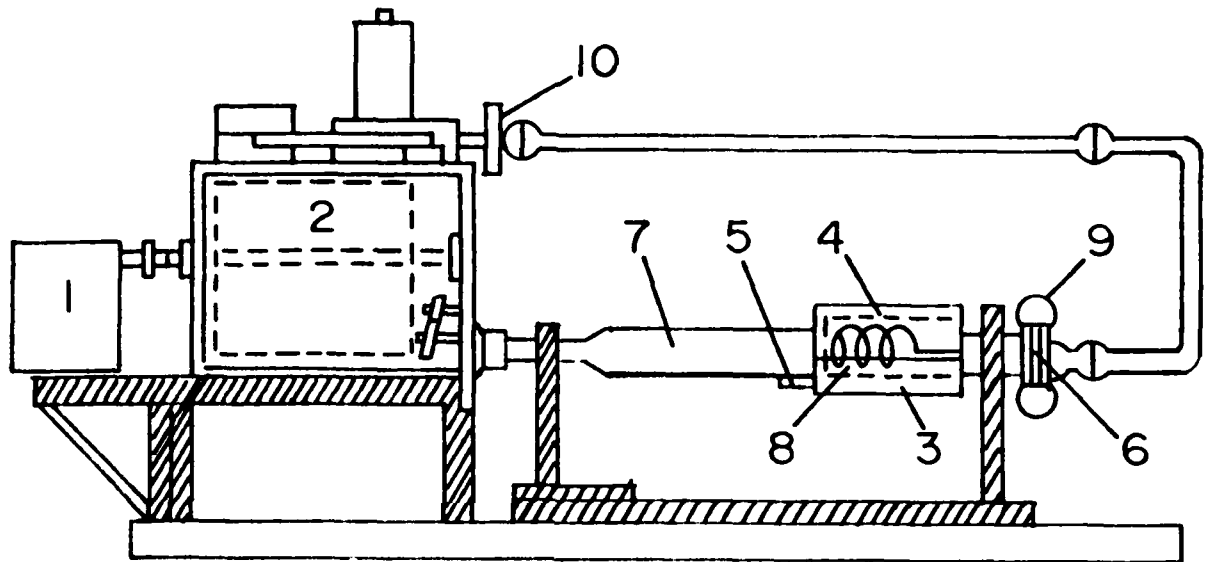

FIGURE 2. COMBUSTION/EXPOSURE ASSEMBLY (12.6 L).

1. Gearmotor, model 3M126, 6 rpm, 1/20 hp; Dayton Manufacturing Company, Chicago, IL
2. Animal exposure chamber
3. Heating unit, model NV2X6, 425 W at 57.5 V, semicylindrical; Watlow Electric Manufacturing Co., 12001 Lackland Road, St. Louis, MO
4. Same as No. 3
5. Thermocouple, chromel-alumel; Omega Engineering Inc., Stamford, CT
6. Hot wire igniter
7. Combustion tube, quartz, 2-inch-diameter
8. Combustion boat
9. Spring clamp
10. Smoke detector

TABLE 1. TOXICITY RANKING OF AIRCRAFT PANEL MATERIALS BY TIME-TO-INCAPACITATION FOR FOUR TEST CONDITIONS

Rank*	Combustion Tube				Radiant Furnace			
	600 °C		750 °C, FL		5 W/cm ²		7.5 W/cm ² , FL	
	Panel Number	t _i , min	Panel Number	t _i , min	Panel Number	t _i , min	Panel Number	t _i , min
1	1	8.1	3	3.3	2	10.7	4	7.3
2	3	8.4	7	3.6	3	10.7	3	7.4
3	4	10.0	1	3.7	1	12.3	7	7.8
4	2	10.1	4	3.9	4	12.8	1	8.3
5	5	13.9**	6	4.1	7	13.9	6	9.3
6	8	17.8	5	6.1	5	14.2	8	9.6
7	6	NR-30	8	6.1	6	14.7	2	10.0
8	7	NR-30	2	7.3	8	23.1**	5	12.4
9	9	NR-30	9	9.1	9	23.7**	9	17.7

FL = Flaming combustion, hot wire igniter used.

NR-30 = No animal response within the 30-min observation period.

* Materials are ranked from No. 1 (most toxic, shortest t_i) to No. 9 (least toxic, longest t_i).

** The mean t_i shown is for a single test only; in the second test, one or more animals were not incapacitated during the observation period.

TABLE 2. PERCENT OF TOTAL COMBUSTIBLE WEIGHT
LOST DURING TEST*

Panel	Test	Combustion Tube		Radiant Furnace	
		600 °C	750 °C, FL	5 W/cm ²	7.5 W/cm ² , FL
1. Epoxy/Fiberglas Honeycomb	1	92	99	--	97
	2	92	99	78	96
2. Phenolic/Fiberglas Honeycomb	1	--	98	77	94
	2	81	100	67	94
3. Epoxy/Kevlar - Honeycomb	1	68	100	82	94
	2	75	100	80	94
4. Phenolic/Kevlar Honeycomb	1	--	100	74	96
	2	66	100	61	90
5. Phenolic/Graphite Honeycomb	1	28	96	38	51
	2	22	84	30	51
6. Polyether-ether- ketone/Polyimide/ Fiberglas Honeycomb	1	12	100	37	79
	2	ST	100	23	70
7. Acrylonitrile- butadiene-styrene/ Polyvinylchloride	1	92	100	97	98
	2	ST	100	94	96
8. Polycarbonate Thermoplastic Sheet	1	82	100	78	87
	2	75	100	73	88
9. Polyetherimide Thermoplastic Sheet	1	20	74	22	53
	2	ST	70	18	54

-- Indicates residue not weighed; i.e., not recovered intact.

* Percent of combustible weight lost was calculated by dividing the weight loss fraction of the sample pyrolyzed under the test condition by the weight loss fraction of a corresponding sample pyrolyzed for 3.3 h at 850 °C and multiplying the quotient by 100.

FL = Flaming combustion, hot wire igniter was used.

ST = Single test only, CO + HCN were insufficient to produce incapacitation at this condition. The notation applies to the 600 °C combustion tube tests only.

REFERENCES

1. Airworthiness Standards: Transport Category Airplanes, DOT/FAA, Federal Aviation Regulations, Vol. III, Part 25, Transmittal 10, effective May 1, 1972.
2. Crane CR, Sanders DC, Endecott BR, Abbott JK, Smith PW. Inhalation Toxicology: I. Design of a Small-Animal Test System. II. Determination of the Relative Toxic Hazards of 75 Aircraft Cabin Materials. Washington, DC: Federal Aviation Administration Office of Aviation Medicine Report No. FAA-AM-77-9, 1977.
3. Crane CR, Sanders DC, Endecott BR, Abbott JK. Inhalation Toxicology: III. Evaluation of Thermal Degradation Products from Aircraft and Automobile Engine Oils, Aircraft Hydraulic Fluid, and Mineral Oil. Washington DC: Federal Aviation Administration Office of Aviation Medicine Report No. FAA-AM-83-12, 1983.
4. Eklund TI. Quasi-Steady Analysis of Aircraft Panel Flammability. Washington, DC: Department of Transportation/Federal Aviation Administration Report No. DOT/FAA/CT-84/14, 1984.
5. Sarkos CP, Filipczak RA, Abramowitz A. Preliminary Evaluation of an Improved Flammability Test Method for Aircraft Materials. Washington, DC: Department of Transportation/Federal Aviation Administration Report No. DOT/FAA/CT-84/22, 1984.
6. Steel RCD, Torrie JH. Principles and Procedures of Statistics. New York: McGraw-Hill, 1960.

END

Dtjic

7-86