

NATIONAL BUREAU OF S
MICROCOPY RESOLU1 TEST

FPO
8513

FPO-1-85 (13)

①

DTIC
ELECTE
S D
JUN 16 1985
D

AD-A168 454



**NAVAL WEAPONS
STATION
CHARLESTON
FLEET MOORINGS
UNDERWATER
INSPECTION
REPORT**

*Original contains color
plates: All DTIC reproductions
will be in black and
white*

JUNE 1985

**OCEAN ENGINEERING
AND CONSTRUCTION PROJECT OFFICE
CHESAPEAKE DIVISION
NAVAL FACILITIES ENGINEERING
COMMAND
WASHINGTON, D.C. 20374**

DTIC FILE COPY

DISTRIBUTION STATEMENT A
Approved for public release;
Distribution Unlimited

86 6 12 137

Unclassified

SECURITY CLASSIFICATION OF THIS PAGE

REPORT DOCUMENTATION PAGE

1a. REPORT SECURITY CLASSIFICATION

Unclassified

1b. RESTRICTIVE MARKINGS

2a. SECURITY CLASSIFICATION AUTHORITY

3. DISTRIBUTION AVAILABILITY OF REP.
Approved for public release;
distribution is unlimited

2b. DECLASSIFICATION/DOWNGRADING SCHEDULE

4. PERFORMING ORGANIZATION REPORT NUMBER
FPO-1-85(13)

5. MONITORING ORGANIZATION REPORT #

6a. NAME OF PERFORM. ORG.
Ocean Engineering
& Construction
Project Office
CHESNAVFACENGCOM

6b. OFFICE SYM

7a. NAME OF MONITORING ORGANIZATION

6c. ADDRESS (City, State, and Zip Code)
BLDG. 212, Washington Navy Yard
Washington, D.C. 20374-2121

7b. ADDRESS (City, State, and Zip)

8a. NAME OF FUNDING ORG.

8b. OFFICE SYM

9. PROCUREMENT INSTRUMENT INDENT #

8c. ADDRESS (City, State & Zip)

10. SOURCE OF FUNDING NUMBERS

| PROGRAM ELEMENT # | PROJECT # | TASK # | WORK UNIT ACCESS # |
|-------------------|-----------|--------|--------------------|
|-------------------|-----------|--------|--------------------|

11. TITLE (Including Security Classification)

Naval Weapons Station Charleston Fleet Moorings Underwater Inspection Report

12. PERSONAL AUTHOR(S)

13a. TYPE OF REPORT

13b. TIME COVERED
FROM TO

14. DATE OF REP. (YYMMDD)
85-06

15. PAGES
48

16. SUPPLEMENTARY NOTATION

17. COSATI CODES
FIELD GROUP SUB-GROUP

18. SUBJECT TERMS (Continue on reverse if nec.)
Fleet moorings, Mooring systems, Mooring inspection. Underwater inspection, Naval Weapons Station Charleston

19. ABSTRACT (Continue on reverse if necessary & identify by block number)

This report contains the results of the inspection of three fleet moorings located within the Naval Weapons Station, Charleston, South Carolina. A CHESDIVNAVFACENGCOM-assigned Engineer-in-Charge and divers from Underwater Construction Team One conducted the inspection from 1 to 5 April 1985. (Con't)

20. DISTRIBUTION/AVAILABILITY OF ABSTRACT
SAME AS RPT.

21. ABSTRACT SECURITY CLASSIFICATION

22a. NAME OF RESPONSIBLE INDIVIDUAL
Jacqueline B. Riley

22b. TELEPHONE
202-433-3881

22c. OFFICE SYMBOL

DD FORM 1473, 84MAR

SECURITY CLASSIFICATION OF THIS PAGE

BLOCK 19 (Con't)

Of the three moorings inspected, the Mediterranean Mooring, ARDM-2, and the Auxiliary Mooring's Buoy was found to be in poor condition. Only 8 of the 13 legs of the ARDM-2 were inspected. A summary of these results is contained in Annex A.

The Auxiliary Mooring's Buoy should be removed from the water before it sinks. Due to measurements slightly greater than 80 percent of original wire diameter, it is recommended that legs C, J, and K be changed out during the next scheduled maintenance period.

Detailed information and specific comments concerning each of these moorings are included within this report.

ABSTRACT

This report contains the results of the inspection of three fleet moorings located within the Naval Weapons Station, Charleston, South Carolina. A CHESDIVNAVFACECOM-assigned Engineer-in-Charge and divers from Underwater Construction Team One conducted the inspection from 1 to 5 April 1985.

Of the three moorings inspected, the Mediterranean Mooring, ARDM-2, and the Auxiliary Mooring's chain were found to be in satisfactory condition, while the Auxiliary Mooring's Buoy was found to be in poor condition. Only 8 of the 13 legs of the ARDM-2 were inspected. A summary of these results is contained in Annex A.

The Auxiliary Mooring's Buoy should be removed from the water before it sinks. Due to measurements slightly greater than 80^{9/16} percent of original wire diameter, it is recommended that legs C, J, and K be changed out during the next scheduled maintenance period. *Recommend: Elect mooring. ←*

Detailed information and specific comments concerning each of these moorings are included within this report.

| | |
|---------------------|-------------------------------------|
| Accession For | |
| NTIS CRA&I | <input checked="" type="checkbox"/> |
| DTIC TAB | <input type="checkbox"/> |
| Unannounced | <input type="checkbox"/> |
| Justification | |
| By _____ | |
| Distribution/ _____ | |
| Availability Codes | |
| Dist | Availability and/or Special |
| A-1 | |



TABLE OF CONTENTS

| Paragraph | Title | Page |
|--------------|---|------|
| 1.0 | INTRODUCTION | 1 |
| 1.1 | Background | 1 |
| 1.2 | General Mooring History | 1 |
| 1.2.1 | Mediterranean Mooring | 1 |
| 1.2.2 | Auxiliary Mooring | 4 |
| 1.2.3 | ARDM Mooring | 4 |
| 2.0 | INSPECTION PROCEDURES | 6 |
| 2.1 | Inspection Objectives | 6 |
| 2.1.1 | Chain Wire Diameter Measurements | 6 |
| 2.1.2 | Inspection Limits | 7 |
| 2.2 | Buoy | 7 |
| 2.3 | Riser Subassembly..... | 7 |
| 2.4 | Anchor Chain Subassembly..... | 8 |
| 3.0 | INSPECTION SUMMARY | 9 |
| 4.0 | MOORING INSPECTION COMMENTS AND RECOMMENDATIONS | 11 |
| Annex | | |
| A | FLEET MOORING INSPECTION RESULTS | A-1 |
| B | PHOTOGRAPHS | B-1 |
| C | SURVEY DATA | C-1 |
| D | REFERENCES | D-1 |

WPNSTA CHARLESTON FLEET MOORING INSPECTION

1.0 INTRODUCTION

1.1 Background. Under the COMNAVFACECOM Fleet Mooring Maintenance (FMM) Program, CHESNAVFACENGCOM has been assigned the responsibility to plan and conduct periodic diver inspections of all fleet moorings worldwide. In carrying out this responsibility, CHESNAVFACENGCOM designated an Engineer-in-Charge (EIC) to provide inspection planning and onsite technical direction for the underwater inspection of fleet moorings located at the Naval Weapons Station (WPNSTA) Charleston, South Carolina. The actual underwater portion of the inspection was performed by divers of Underwater Construction Team One (UCT ONE). The inspection was conducted from 1 to 5 April 1985.

1.2 General Mooring History. A total of three fleet moorings are currently operated and maintained by WPNSTA Charleston: a Mediterranean mooring, an auxiliary mooring, and an ARDM mooring. Each of these moorings is installed in the Cooper River within half a mile of Pier C at the Weapons Station. Figure 1 shows the general geographic position of the project site, and Figure 2 shows the locations of the moorings. A brief description of each of these moorings follows:

1.2.1 Mediterranean Mooring. The Mediterranean mooring consists of two stakepiles which are positioned to the port and starboard of the tender's bow. Three and one-half inch cast chain connects the 300 KIP stakepiles to

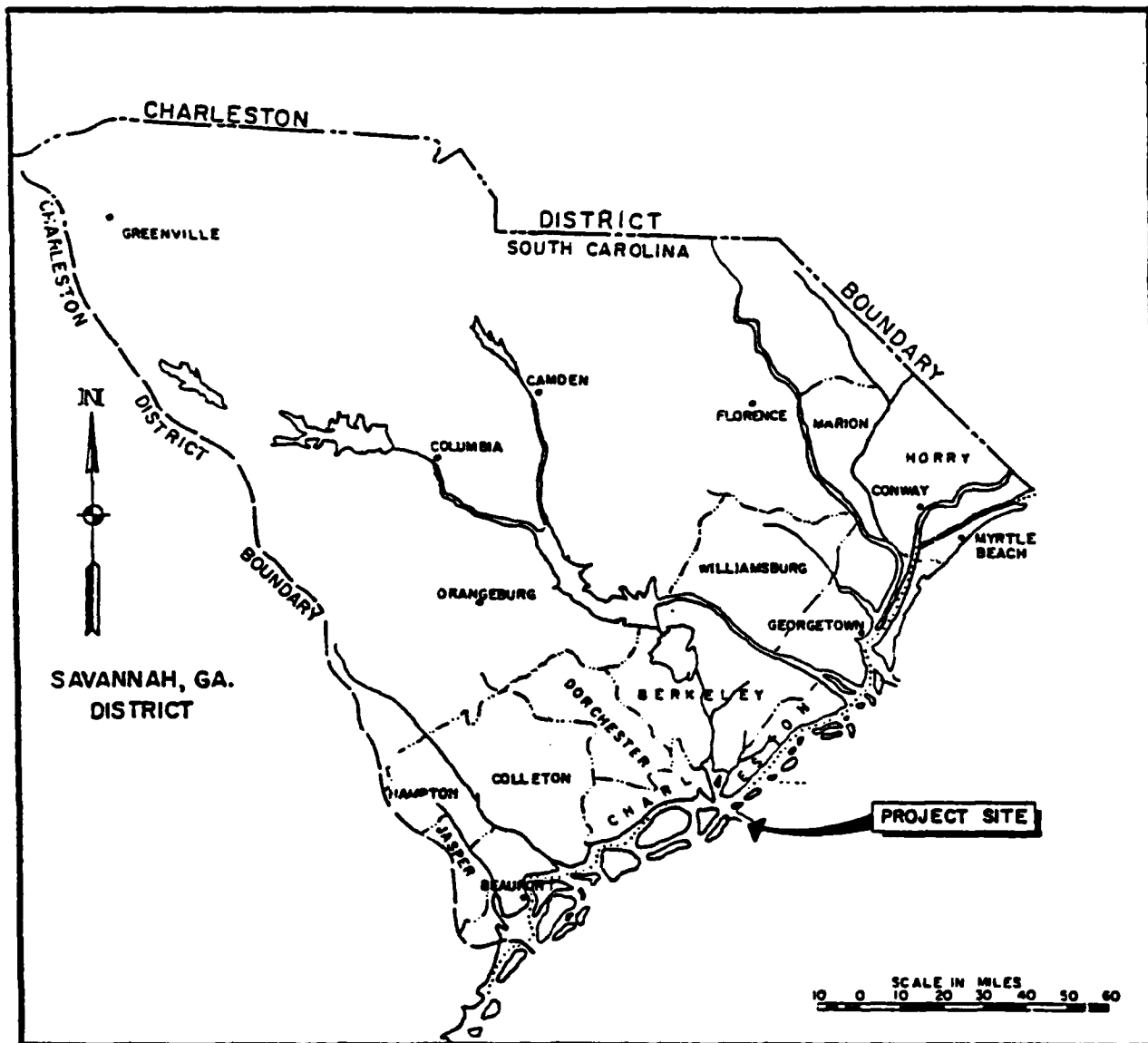

Figure 1. Charleston District Vicinity Map

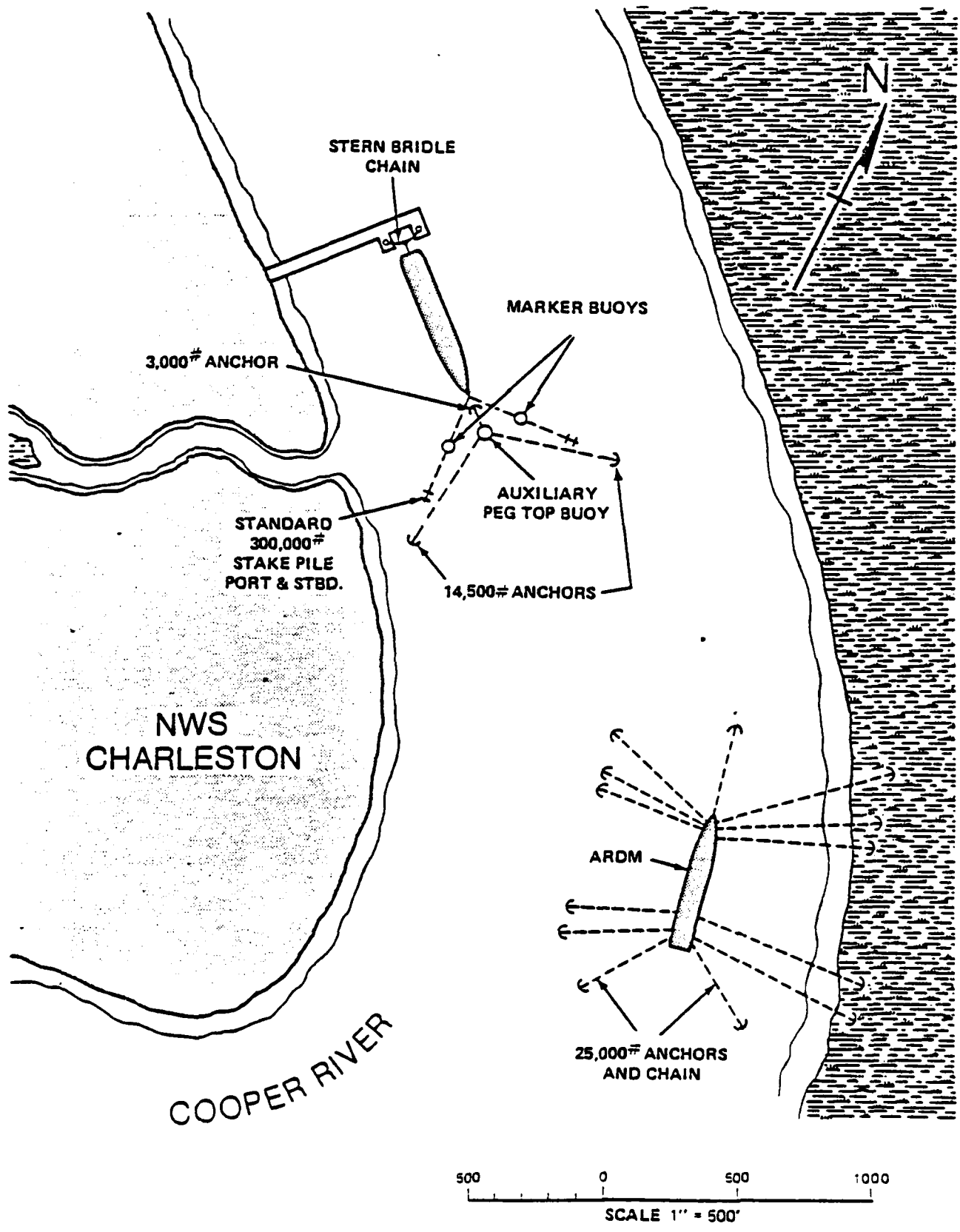

Figure 2. Mooring Locations

moor the bow of a tender, and the stern of the tender is moored to the pier.

(Note: The marker buoys shown in Figure 2 and 3 are used as navigation aids when the Tender is in its mooring and as retriever buoys when the tender is out of its mooring. When the tender is out of its mooring, red and green navigation buoys are also attached to the marker buoys for additional aid in navigation from Pier C.)

1.2.2 Auxiliary Mooring. The auxiliary mooring is a riser-type mooring located directly off the bow of the tender and between the two stakepiles of the Mediterranean mooring. It is used by the tender to facilitate mooring to the Mediterranean mooring.

1.2.3 ARDM Mooring. The Auxiliary Recovery Drydock Medium (ARDM) mooring is used to anchor a floating drydock. There are 13 legs in this mooring, each attached to a 25,000-pound anchor. An impressed current cathodic protection system has been installed on the ARDM. Figure 3 is a schematic diagram of the designed ARDM mooring.

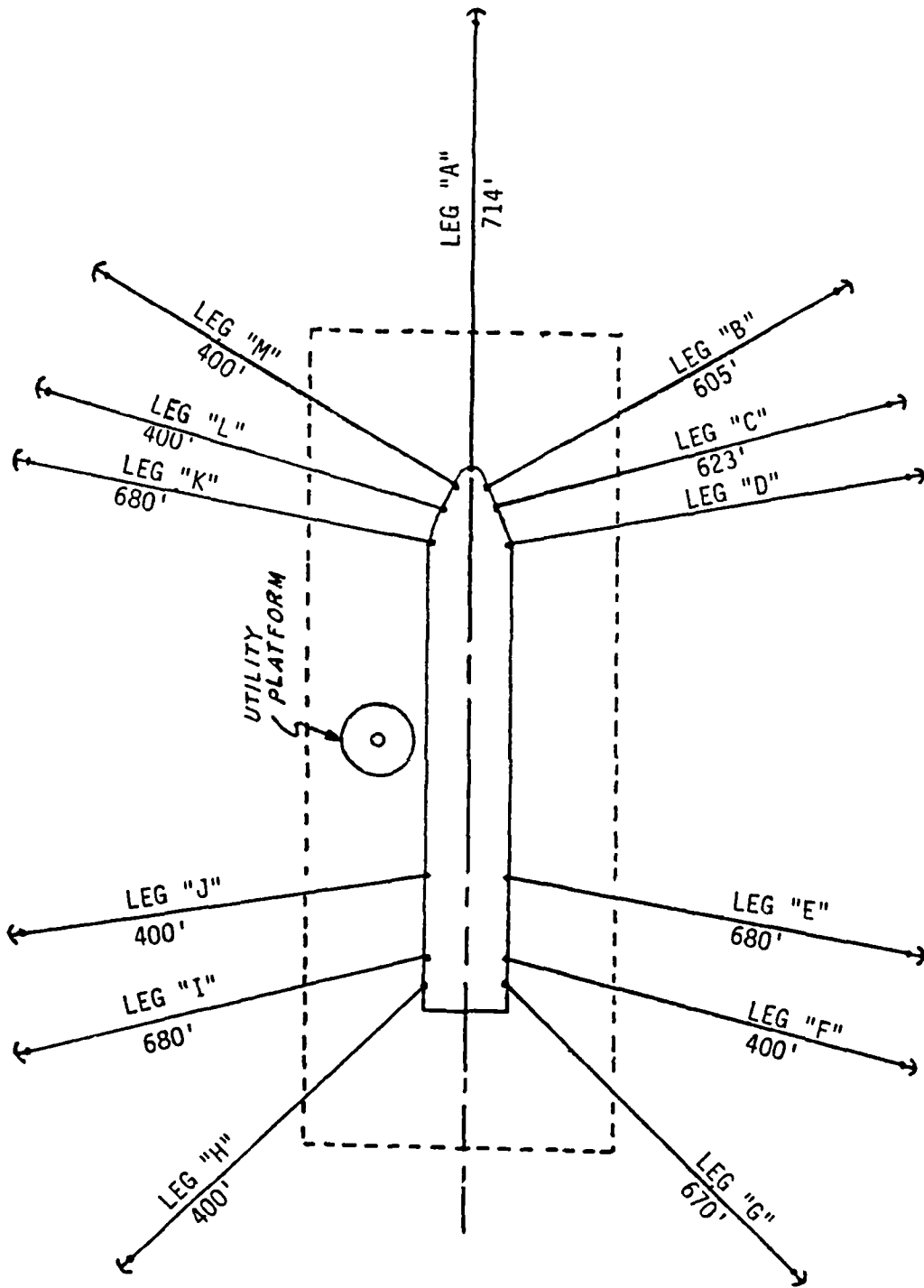

FIGURE 3. SCHEMATIC OF DESIGNED ARDM-2 MOORING
(Not To Scale)

2.0 INSPECTION PROCEDURES

2.1 Inspection Objectives. The purpose of the mooring inspection was to determine the general condition of the buoys and chain assemblies and, when possible, to verify or update existing as-built and maintenance records. Divers inspected only a portion of the submerged buoy hull and chain assemblies in order to compile a general description of the mooring's condition. The existence of fairly consistent measurements during this inspection provides a good indication of the mooring's overall condition. It should be kept in mind that periodic underwater inspections are intended as an expedient and relatively inexpensive supplement to accurate maintenance records.

2.1.1 Chain Wire Diameter Measurements. Chain wire diameter measurements are used to evaluate the condition of a mooring. A selective sampling of the wire diameter of chain links and connecting hardware was taken in order to determine the amount of deterioration due to corrosion and wear. At each sampling area, the chain was cleaned to bare metal. Single-link measurements were taken where the chain was slack to detect corrosion loss. Double-link measurements were taken where two links connected under tension to detect the combined effects of corrosion and wear. Chain links and other components which measured 90 percent or greater of original wire diameter are considered to be in "good" condition; measurement between 80 and 90 percent of original diameter is considered "fair" condition and is cause for the mooring to be downgraded in classification; any measurement less than 80 percent is considered "poor" and is cause for the mooring to be declared unsatisfactory for fleet use.

2.1.2 Inspection Limits. Standard underwater inspection procedures do not call for the inspection of any part of the mooring which has been buried or which is below a water depth of 130 feet if scuba gear is used. Anchor chain and riser subassemblies were observed only to the point at which they became buried; no attempt was made to locate and inspect anchors or other mooring materials which were not readily visible.

2.2 Buoy. The buoy was inspected as follows:

2.2.1 Buoy Topside. Each buoy was inspected to determine its general condition. The buoy markings were checked for conformance to those noted in applicable charts. Physical damage such as holes, dents, or listing, was described. Hatches, openings, and penetrations were examined and worn material and rust were reported. The buoy fenders and chafing strips were checked for integrity and secure connection to the buoy. Buoy top jewelry was measured with calipers to find the overall outside dimensions and areas of most severe reduction in wire size.

2.2.2 Buoy Lower Portion. Divers inspected the buoy below the waterline and recorded the thickness of marine growth and the condition of the buoy bottom.

2.3 Riser Subassembly. To determine chain wear, each riser chain was inspected by taking three consecutive double-link measurements, using pre-cut gauges and/or calipers, at both ends and at the center of the riser. To

determine original chain size, divers took single-link measurements of the wire diameter and measured the link length. (Link length should be six times the wire diameter.)

2.4 Anchor Chain Subassemblies. Using pre-cut gauges and calipers, UCT ONE divers took sample measurements of the anchor chain subassemblies.

3.0 INSPECTION SUMMARY

An indepth discussion of the inspection results is presented in Annex A. Annex B contains photographs, and Annex C contains a copy of the inspection survey data. An evaluation of the data gathered during the inspection indicates the following:

Mediterranean Mooring:

- o Visible sections of the bow and stern legs are in good condition
- o The two bow legs are heavily pitted and rusted near the waterline, and each is covered with a relatively thick marine growth.

Auxiliary Mooring:

- o This mooring's buoy is in poor condition.
- o The buoy has a 54° list that could be caused by loss of water tight integrity. It is badly pitted and rusted.
- o The riser chain and ground legs are in good condition.
- o Voltmeter readings showed that the cathodic protection system is working properly.

ARDM Mooring:

- o Only 8 legs out of 13 were inspected due to repairs taking place on the ARDM.
- o Seven of the ARDM legs measure greater than 90 percent of original wire diameter. Leg C, however, was measured to be barely greater than 80 percent where it is attached to the hull of the ARDM. The remainder of the leg was measured to be greater than 90 percent of its original wire diameter.

- o Of the eight inspected legs, only legs A, B, G, and M have catenaries. The remaining legs (C, D, F, and L) are slack and drop vertically into the bottom.
- o Ground legs J and K were not inspected this time because of barge positions. Both legs at last inspection had between 80 and 90 percent measurements of their initial wire diameters.

4.0 MOORING INSPECTION COMMENTS AND RECOMMENDATIONS

Mediterranean Mooring:

- o The bow legs, stern legs, and marker buoys are in satisfactory condition for continued use.
- o The stern legs should be placed on the pier when not in use.

Auxiliary Mooring:

- o The buoy should be removed from the water before it sinks. The cause of its list should be determined and the buoy overhauled or replaced. The remainder of the mooring is in good condition.

ARDM Mooring:

- o The mooring is in satisfactory condition for continued fleet use.
- o The top two links in ground leg C should be removed during the next maintenance period.
- o In repositioning the ARDM after dredging, the chain catenaries should be checked to insure proper ARDM mooring position.
- o During this inspection, Leg C was found to have measurements near 80 percent. During the last inspection, Legs J and K (which were not inspected this time) were found to have measurements between 80 and 90 percent. Therefore, it is recommended that all three of these legs be changed out during the next scheduled maintenance period.

ANNEX A
FLEET MOORING
INSPECTION RESULTS

SUMMARY OF INSPECTION

MEDITERRANEAN MOORING

Bow Anchor Chain Subassemblies. Both bow legs consist of 3 1/2-inch cast chain, all of which measured greater than 90 percent of original wire diameter. The port leg bears approximately 108° magnetic from the bow of the tender and the starboard leg bears approximately 200° magnetic (see Figure A-1).

The divers reached the cast iron sinkers of the port leg and found the chain on the bottom not under tension. The stakepiles of each leg were buried. Inclinator readings were recorded on each leg as shown below:

| | Starboard Leg | Port Leg |
|------------------|---------------|----------|
| Angle at surface | 80° | 66° |
| Angle at bottom | 70° | 71° |
| Chain length | 95' | 110' |

Stern Legs. The stern legs consist of 3 1/2-inch cast and Dilok chain and are connected to the southeast end of Pier C. Chain measurements were greater than 90 percent of original wire diameter but showed some surface rust. A schematic diagram of the moorings stern leg assemblies is contained in Figure A-2.

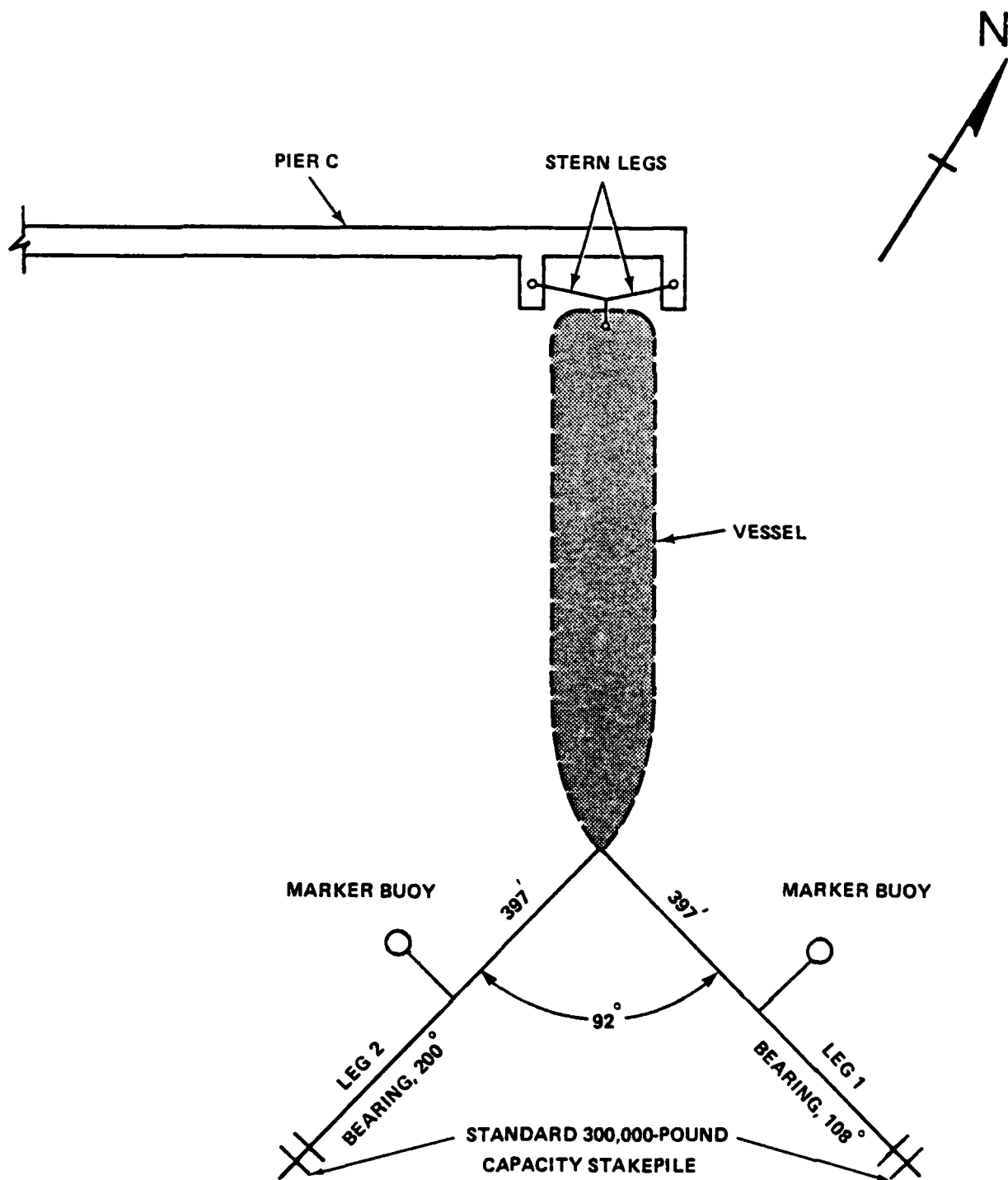

Figure A-1. Design Schematic of WPNSTA Charleston's Mediterranean Mooring.

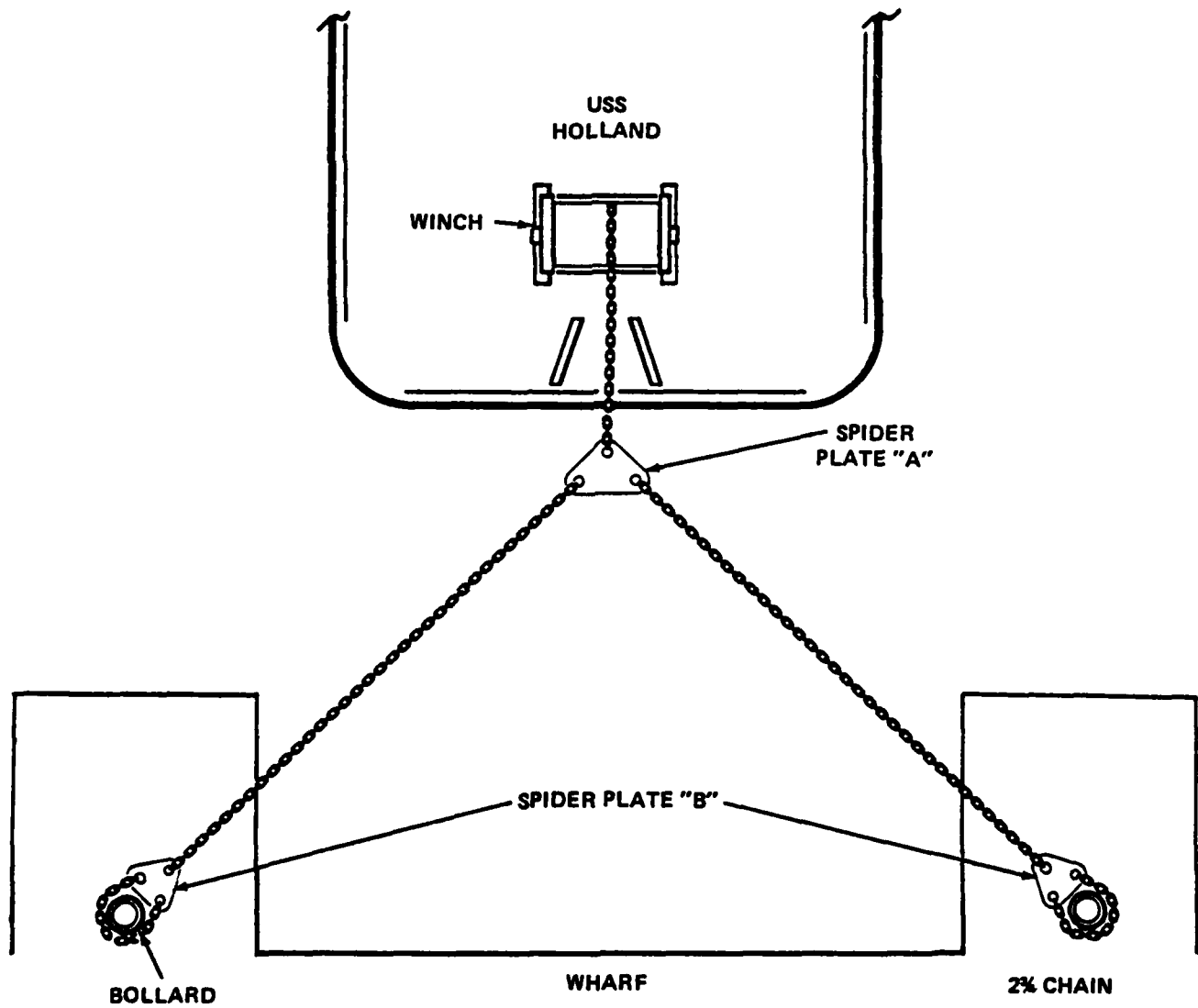

Figure A-2. USS HOLLAND (AS-32) Stern Legs

Marker Buoys.

Currently, large rubber fenders (normally used for protection of yard craft) are being used in place of buoys. One is located about halfway between each stakepile and the tender. (See Figure 2.) They are used as retriever buoys and navigation aids during tender mooring operations. Each marker buoy is attached by 3/8-inch steel wire rope to a shackle which is connected to the mooring chain (see Figure A-3). The fenders are in place and in good condition with moderate to light marine growth.

Comments and Recommendations.

- o The visible portions of the bow legs and the stern legs are in good condition.
- o The retriever buoys are in good condition.
- o When the tender is away from the mooring, the stern legs are dropped in the water. To reduce corrosion, it is recommended that the stern legs be placed on the pier when not in use.

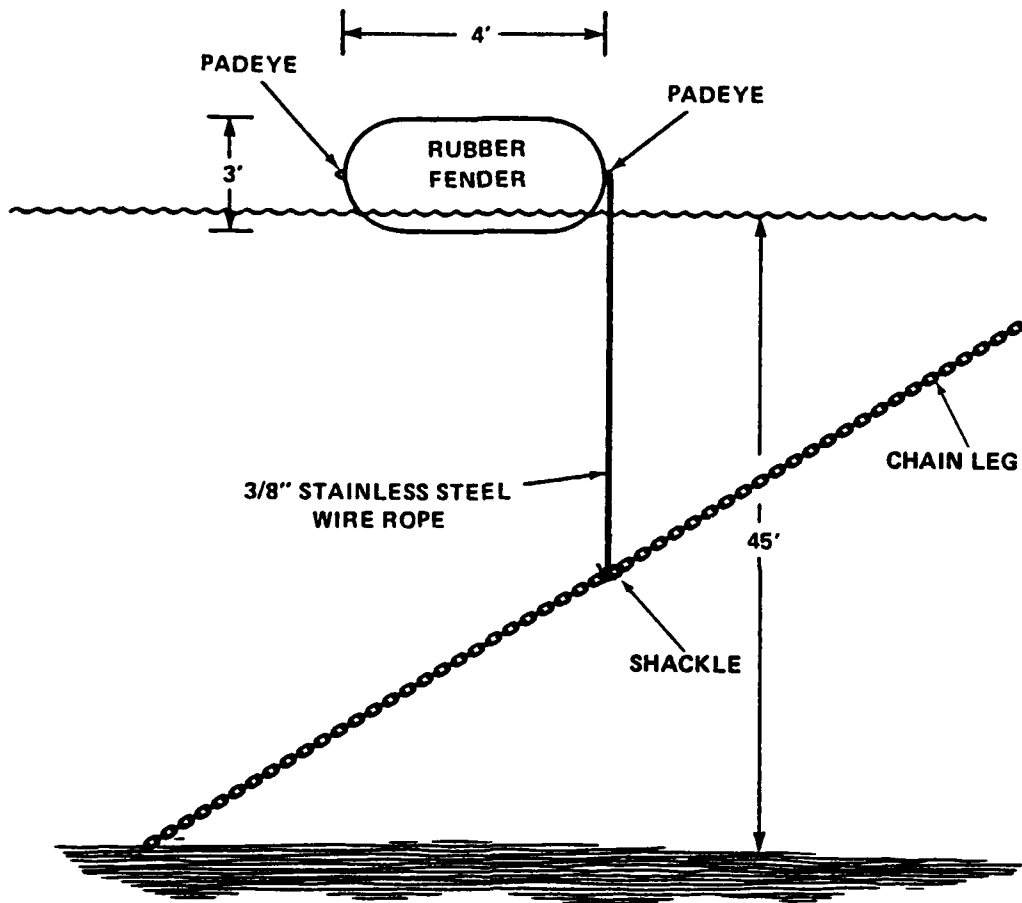

Figure A-3 Mediterranean Mooring Bow Leg Marker Buoy

MOORING NO.: STBD BOW CLASS: MEDITERRANEAN LOCATION: NIMS CHARLESTON SC LAT: 32°55' 14.21" N LONG: 79°55' 57.66" E

BUOY TYPE: PICK UP (FEEDER) ANCHOR SIZE/TYPE: STAKE PILE WATER DEPTH: 45' VISIBILITY: 0-1' BOTTOM TYPE: MUD

DATE: 1-2 APR 85 ENGINEER-IN-CHARGE: P. KETRICK DIVERS: DORVAL/0221

| COMPONENTS | GAUGE SIZE | CONDITION | | | | | | COMMENTS |
|-----------------|------------|-------------|---------------|-----|---------------|-----|-------|-------------------------------------|
| | | LINK LENGTH | SINGLE LINK % | | DOUBLE LINK % | | DEPTH | |
| | | 90+ | 80+ | 80- | 90+ | 80+ | 80- | |
| BUOY HARDWARE | | | | | | | | |
| | | | | | | | | 4' x 3' RUBBER FEEDER IS USED AS A |
| | | | | | | | | BACKUP BWOY. GOOD CONDITION. HELD |
| | | | | | | | | IN PLACE BY 3/8" WIRE TO CHAIN LEG. |
| | | | | | | | | |
| | | | | | | | | |
| PICK UP WIRE | 3/8" | | | | | | | 0 |
| MIDDLE | ↓ | | | | | | | 10' |
| BOTTOM | | | | | | | | 20' |
| | | | | | | | | |
| GROUND LEG STBD | 3 1/2" | | | | ✓✓✓ | | | |
| MIDDLE | ↓ | | | | ✓✓✓ | | | |
| ENTERS BOTTOM | | | | | ✓✓✓ | | | |
| | | | | | | | | |
| GROUND LEG PORT | | | | | | | | |
| MIDDLE | | | | | | | | |
| ENTERS BOTTOM | | | | | | | | |
| UPPER END | 3 1/2" | ✓✓✓ | | | ✓✓✓ | | | |
| MIDDLE | ↓ | ✓✓✓ | | | ✓✓✓ | | | |
| BOLLARD | 2 3/4" | ✓✓✓ | | | ✓✓✓ | | | |

FOR ADDITIONAL LEGS USE OTHER SHEETS

SHEET 1 OF 2

MOORING NO.: PORT BOW CLASS: MEDITERRANEAN LOCATION: NILES CHARLESTON, SC LAT: 32°55' 15.28" N LONG: 79°55' 55.10" E

BUOY TYPE: PICK UP (FEEDER) ANCHOR SIZE TYPE: STAKE PILE WATER DEPTH: 40' VISIBILITY: 0-1' BOTTOM TYPE: MUD

DATE: 1-2 APR 85 ENGINEER-IN-CHARGE: P. KETRICK DIVERS: EMBERSKI / ALDERS

| COMPONENTS | GAUGE SIZE | CONDITION | | | | | COMMENTS | |
|-----------------|---------------|-------------|---------------|-----|---------------|-----|----------|-------|
| | | LINK LENGTH | SINGLE LINK % | | DOUBLE LINK % | | | DEPTH |
| BUOY HARDWARE | | 90+ | 80+ | 80- | 90+ | 80+ | 80- | |
| NONE | | | | | | | | |
| PICK UP WIRE | NEAR BUOY | | | | | | | 0' |
| | MIDDLE | | | | | | | 10' |
| | BOTTOM | | | | | | | 26' |
| GROUND RING | | | | | | | | |
| GROUND LEG STBD | UPPER END | | | | | | | |
| | MIDDLE | | | | | | | |
| | ENTERS BOTTOM | | | | | | | |
| GROUND LEG PORT | UPPER END | | | | ✓✓✓ | | | |
| | MIDDLE | | | | ✓✓✓ | | | |
| | ENTERS BOTTOM | | | | ✓✓✓ | | | |
| STERN LEGS | UPPER END | ✓✓✓ | | | ✓✓✓ | | | |
| | MIDDLE | ✓✓✓ | | | ✓✓✓ | | | |
| | BOLLARD | ✓✓✓ | | | ✓✓✓ | | | |

FOR ADDITIONAL LEGS USE OTHER SHEETS SHEET 2 OF 2

SUMMARY OF INSPECTION

AUXILIARY MOORING

Buoy.

This Mark II Peg Top Buoy with hawse pipe measures 12 feet in diameter by 9 1/2 feet high. The buoy has a 54° list which could be caused by failure of its watertight integrity. It has two wooden fenders which are covered with thin steel strips and a 1/4-inch thick steel plate covering the topside. The wooden fenders are splintering and the upper and lower steel plates are badly rusted, loose, and layers of rust are flaking off at the waterline. In addition, the buoy has 1/8-inch deep pitting in its bottom, and the top has a heavy coating of guano. In general, this buoy is in very poor condition and should be removed from the water before it sinks.

Riser.

The 2-inch riser chain is in good condition with all measurements greater than 90 percent. The chain is heavily coated with marine growth with pitting and rust towards the surface. An in-line anode was located at 25 feet. The ground ring was located at 30 feet and is in good condition.

Ground Legs.

About 10 feet below the ground ring (at a depth of 40 feet) the three ground legs drop vertically into the bottom. Each of the ground legs is comprised of 2 3/4-inch forged chain, and measurements of these legs were all above 90 percent of their original wire size. Just below the ground ring, one

of these legs has a zinc anode at the mud line and is partially covered.

Figure A-4 is a schematic drawing of the Auxiliary Mooring.

Comments and Recommendations.

- o The buoy should be removed and the cause of its list determined and repaired.
- o All voltmeter readings are within accepted values.

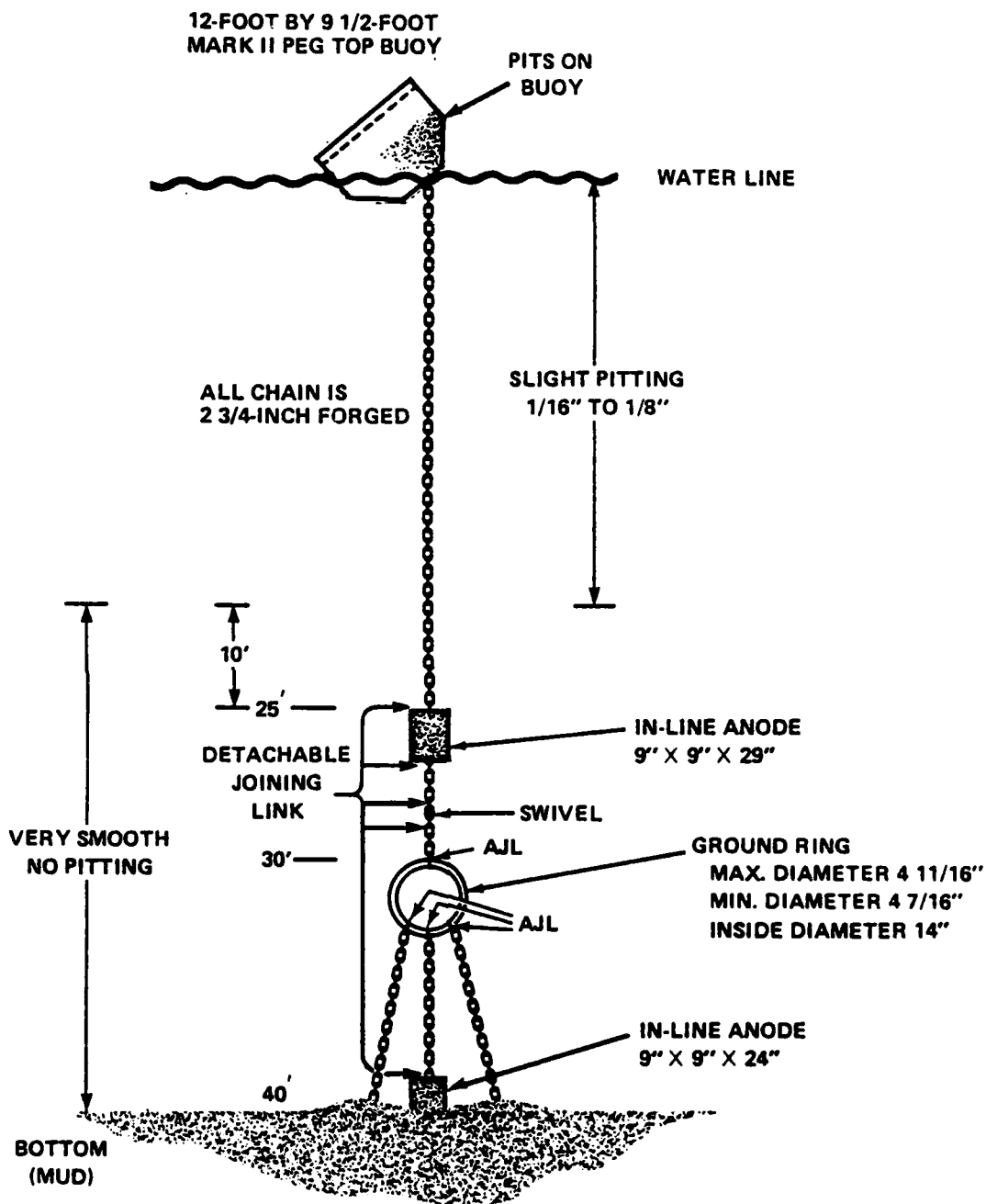

Figure A-4 Auxiliary Mooring

MOORING NO.: Auxiliary Class LOCATION: Charleston, S. Carolina LAT: 33° 55' LONG: 79° 36'
14-769" N
 BUOY TYPE: Peg Top ANCHOR SIZE/TYPE: 14,500# WATER DEPTH: 40' VISIBILITY: 0 BOTTOM TYPE: Mud
 DATE: 4-4-85 ENGINEER-IN-CHARGE: Paul Ketrick DIVERS: Uzzi and Aldens

| COMPONENTS | GAUGE SIZE | LINK LENGTH | CONDITION | | | | COMMENTS | |
|------------------------------|------------|-------------|---------------|-----|---------------|-----|----------|-------|
| | | | SINGLE LINK % | | DOUBLE LINK % | | | DEPTH |
| | | | 90+ | 80- | 90+ | 80- | | |
| BUOY HARDWARE | | | | | | | | |
| 3" Detachable | 3" | 18" | ✓ | | | | | |
| 2 1/4" Detachable | 2 1/4" | 13.5" | ✓ | | | | | |
| Downthaul Block 22" x 18" | | | | | | | | |
| | | | | | | | | |
| NEAR BUOY | 2" | 12" | | | ✓✓ | | | |
| MIDDLE | ↓ | ↓ | | | ✓✓ | | | |
| NEAR GRD RG | ↓ | ↓ | | | ✓✓ | | | |
| GROUND RING | 4 3/4" | | ✓ | | | | 30' | |
| UPPER END | 2" | 12" | | | ✓✓ | | | |
| MIDDLE | Buried | | | | | | | |
| ENTERS BOTTOM | ↓ | ↓ | | | | | | |
| UPPER END | 2" | 12" | | | ✓✓ | | | |
| MIDDLE | Buried | | | | | | | |
| ENTERS BOTTOM | ↓ | ↓ | | | | | | |
| UPPER END | 2" | 12" | | | ✓✓ | | | |
| MIDDLE | Buried | | | | | | | |
| ENTERS BOTTOM | ↓ | ↓ | | | | | | |
| UPPER END | 2" | 12" | | | ✓✓ | | | |
| MIDDLE | Buried | | | | | | | |
| ENTERS BOTTOM | ↓ | ↓ | | | | | | |
| UPPER END | 2" | 12" | | | ✓✓ | | | |
| MIDDLE | Buried | | | | | | | |
| ENTERS BOTTOM | ↓ | ↓ | | | | | | |

FOR ADDITIONAL LEGS USE OTHER SHEETS SHEET OF

SUMMARY OF INSPECTION

ARDM-2-MOORING

ARDM Legs.

Leg A. This leg is a 2 3/16-inch cast chain manufactured by NACO and is in good condition. The portion of the chain near the water line is heavily pitted (1/4-inch deep), has minimal rust, and the chain near the bottom has no pitting and is covered with barnacle-type marine growth. Double-link measurements indicated that all of the chain is greater than 90 percent of its original wire diameter.

Leg B. This leg is 2 3/16-inch cast chain manufactured by NACO and is in good condition. Heavy pitting can be seen. There are thick barnacles near the waterline and on submerged portions of the chain. All double link measurements were greater than 90 percent of its original wire diameter. A detachable link was noted at a depth of 12 feet.

Leg C. This leg is 2 3/4-inch cast chain and is in good condition. The chain drops vertically to the bottom. All double link measurements were greater than 90 percent except for the first two links connected to the ARDM. These links are very near 80 percent. Marine growth is heavy at the surface and light towards the bottom. The chain is heavily pitted with the upper end showing the most severe pitting. Pits as large as 1/4-inch in diameter by 1/4-inch deep were found.

Leg D. This leg is 2 3/4-inch flash-butt-welded chain and is in good condition. The chain drops vertically to the bottom and has no catenary. Heavy pitting was observed. Marine growth is heavy at the surface and light

towards the bottom. All single link measurements were greater than 90 percent of their original wire diameter.

Leg F. This leg is 2 3/4-inch Dilok chain and is in good condition. The chain drops vertically to the bottom. All single link measurements were greater than 90 percent of its original wire diameter. The chain is heavily pitted with some pits as large as 1/8-inch wide by 1/8-inch deep. Marine growth was very heavy. A wire rope was found woven through the chain at the mud line.

Leg G. This leg is 2 3/4-inch Dilok chain, and all double link and single link measurements were greater than 90 percent of its original wire diameter. The leg was not under tension, and was visible on the bottom for quite a distance. Detachable links were found at 15-, 20- and 35-foot depths.

Leg L. This leg is 2 3/4-inch cast chain and is in good condition. There is little pitting and no noticeable rust. Heavy marine growth covers most of the chain near the surface. Moss growth can be found above 20 feet and light barnacle growth below 20 feet. Double link measurements were greater than 90 percent. The chain drops vertically into the bottom. A single detachable link was found at a depth of 22 feet.

Leg M. The upper 35 feet of this leg is 2 3/16-inch Dilok chain which is connected by a detachable link to 2 3/16-inch cast chain. The upper section of the chain is badly pitted (1/8-inch deep) and rusted, and the coating is almost gone. No wire rope was found woven through the chain. All double link measurements were greater than 90 percent and the chain is in good condition. Marine growth is minimal with some barnacles on the submerged portion of the chain.

General.

Except for some heavy pitting and rusting, the chain appears to be in fair to good condition. Only four legs out of the eight inspected have catenaries and Table A-1 shows the measurements for these legs. The remaining four legs are slack and drop vertically into the bottom. Figure A-5 shows which legs are under tension, while Table A-2 provides a summation of the condition of the ARDM-2 ground legs.

The ARDM-2, USS ALAMAGORDO, has an impressed current system consisting of port and starboard current power supplies. The impressed current is applied to the hull. When ballasted the ARDM can move about 40 feet to each side. The ARDM mooring is moved every year so that the area underneath and around the ARDM can be dredged to maintain a depth of 50 feet. The center line of the ARDM is presently on a bearing of 345°.

TABLE A-1
CATENARY DATA

| LEG | A | B | G | M |
|---------|-----|------|-----|-----|
| SURFACE | 36° | 38° | 60° | 39° |
| MIDDLE | | | | |
| Depth | 25' | 25' | 18' | 25' |
| Angle | 40° | 55° | 70° | 49° |
| BOTTOM | | | | |
| Depth | 50' | 50' | 35' | 50' |
| Angle | 63° | 75° | 90° | 72° |
| LENGTH | 95' | 135' | 90' | 90' |

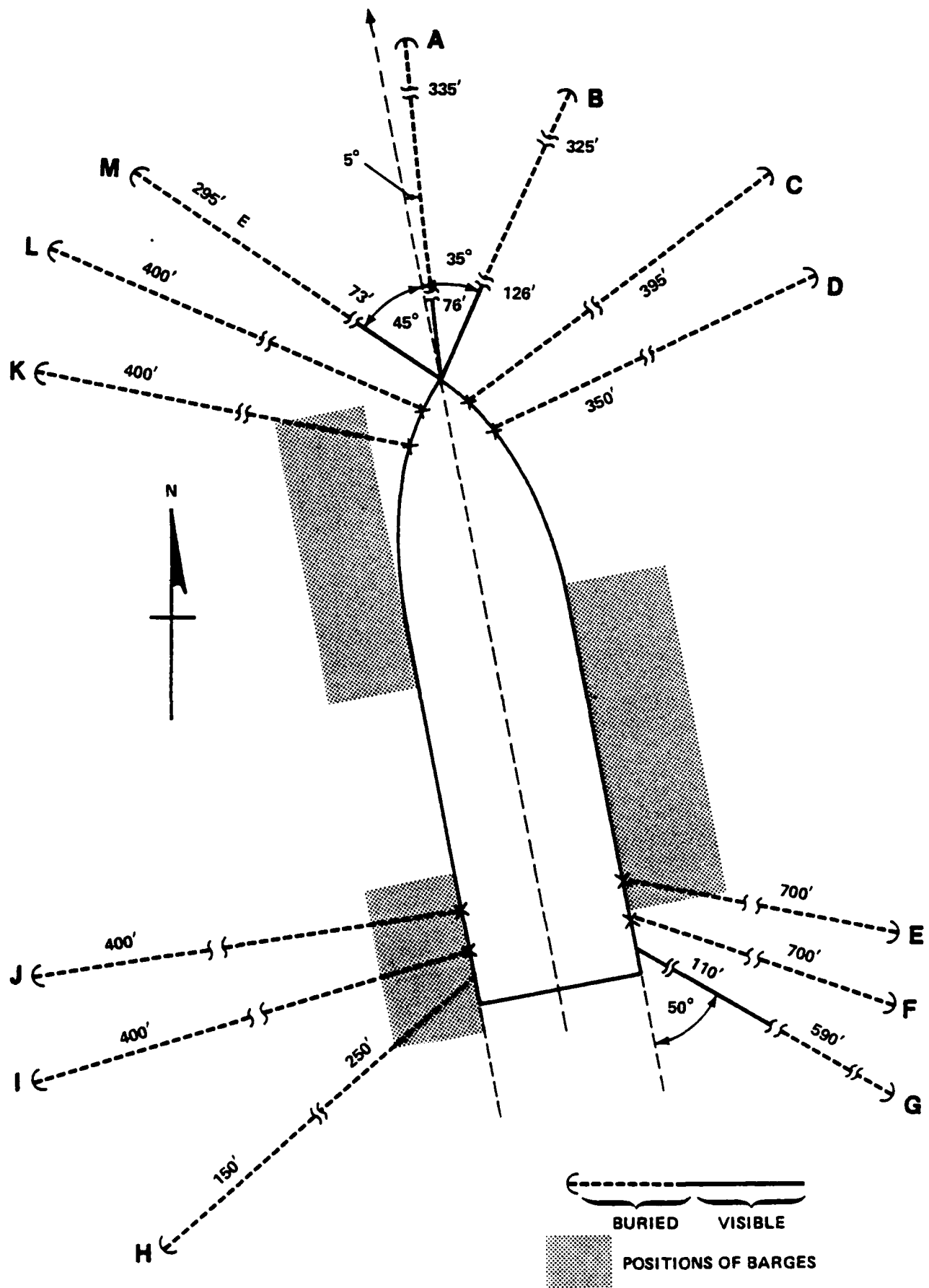

Figure A-5. ARDM LEG POSITIONS

A-16

TABLE A-2

MOORING NO.: ARM-2 CLASS: DRY DOCK LOCATION: NWS CHARLESTON LAT: 32°54'57.329" N LONG: 79°55'39.688" E (BOW)
 WATER DEPTH: 50' ANCHOR SIZE/TYPE: 25,000 lb DIVERS: Dorval, Kravink, Dazzi, Emborski, Alders

BOTTOM TYPE: SAND MUD CLAY CORAL ROCK VISIBILITY: 0 D = depth NI = not inspected, inaccessible

| LEG | TYPE CHAIN | SIZE (in.) | LOCATION | DOUBLE LINK | | SINGLE LINK | MAGNETIC BEARING | CATENARY | COMMENTS |
|-----|------------|------------|---|-------------------------|------|--------------------------------|------------------|----------|---|
| | | | | >90% | <80% | | | | |
| A | Cast | 2 3/16 | On the Bow Upper End Middle Lower End | X X X X X X X X X | | | 350° | Yes | Paint gone marine growth min. Distance of ARM to modli. is 76. |
| B | Cast | 2 3/16 | Starboard Bow Upper End Middle Lower End | X X X X X X X X X | | | 20° | Yes | Heavy pitting, rusted, paint gone. Heavy barnacle growth. Detachable 12' 18' |
| C | Cast | 2 3/4 | Starboard Bow Upper End Middle Lower End | X X X X X X X X X | X X | ≥ 90% X XX XXX XXX | — | No | Heavy Pitting light marine growth Did not find detachables. |
| D | Forged | 2 3/4 | Starboard Bow Upper End Middle Lower End | X X X X X X X X X | | | — | No | Heavy Pitting, marine growth heavy at surface, light bottom. |
| E | Cast | 2 3/4 | Starboard Quarter Upper End Middle Lower End | | | | | | NI |
| F | Dilok | 2 3/4 | Starboard Quarter Upper End Middle Lower End | X X X X X X X X X | | ≥ 90% XXX XXX XXX | — | No | Heavy Pitting marine growth heavy Not find (detach- able mix in chain). |
| G | Dilok | 2 3/4 | Starboard Quarter Upper End Middle Lower End | X X X X X X X X X | | X X X X X X X X X | 115° | Yes | Heavy pitting Detachable at 15, 20, 35'. Chain not under tension -man growth -heavy at top. |

TABLE A-2 (Continued)

MOORING NO.: AKDM-2 CLASS: DRY DOCK LOCATION: NWS CHARLESTON LAT: 32° 54' 59.063" N LONG: 79° 55' 40.147" E (PORT-STERN)

WATER DEPTH: 50' ANCHOR SIZE/TYPE: 25,000 lb DIVERS: Dorval, Emborski, Kronk

BOTTOM TYPE: SAND MUD CLAY ROCK CORAL ROCK Visibility: 1' D = depth NI = not inspected, inaccessible

| LEG | TYPE CHAIN | SIZE (in.) | LOCATION | DOUBLE LINK | | | SINGLE LINK | MAGNETIC BEARING | CATENARY | COMMENTS |
|-----|------------|------------|--|-------------|-------------|-------------|--------------------------------|------------------|--|----------|
| | | | | >90% | >80% | <80% | | | | |
| H | Cast | 2 3/4 | Port Quarter Upper End Middle Lower End | | | | | | NI | |
| I | Cast | 2 3/4 | Port Quarter Upper End Middle Lower End | | | | | | NI | |
| J | Cast | 2 3/4 | Port Quarter Upper End Middle Lower End | | | | | | NI | |
| K | Cast | 2 3/4 | Port Bow Upper End Middle Lower End | | | | | | NI | |
| L | Cast | 2 3/4 | Port Bow Upper End Middle Lower End | X X X | X X X | X X X | 90° X X X X X X X X X | No | No noticeable rust heavy mod. growth, mod. surface Detachable at 20 Chain rod paint lost | |
| M | Dilok/Cast | 2 3/16 | Port Bow Upper End Middle Lower End | X X X | X X X | X X X | | Yes | Badly pitted and rusted. Paint almost gone wire growth mod. (Barnacles) No more wire Rope thru chain | |

Comments and Recommendations.

- o Only 8 legs out of 13 were inspected because of the position of barges around the ARDM-2 (see Figure A-5).
- o With the exception of leg C, which measured between 80 and 90 percent near the hull of the ARDM, all the legs measured greater than 90 percent of their original wire diameter. The links of leg C should be changed out during the next scheduled maintenance period.
- o Four legs, (A, B, G, and M), out of the eight inspected have catenaries. The other four legs, (C, D, F and L), drop vertically into the bottom. Tightening these legs should prevent some of the lateral motion noted.
- o Ground legs J and K were not inspected this time because of barge positions. Both legs, at last inspection, measured near 80 percent of their original wire diameter. It is recommended that these legs be changed out during the next scheduled maintenance period.
- o Due to high currents and large tidal changes, the dive windows are as follows:
 - a) Low tide: 2-3 hours of dive time.
 - b) High tide: 45 minutes to 1 hour of dive time.

ANNEX B
PHOTOGRAPHS

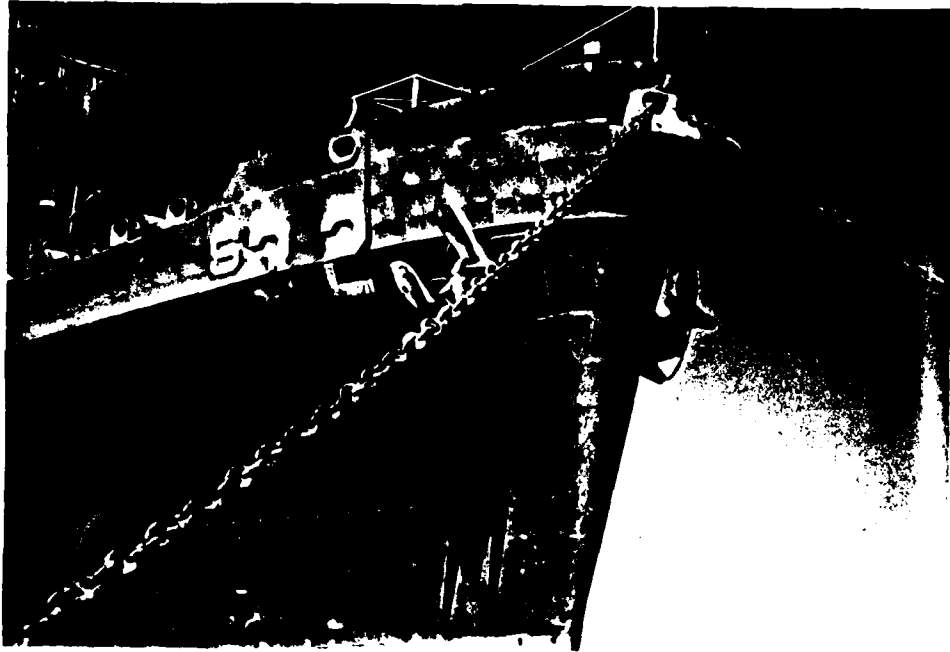

Mediterranean Mooring's Starboard
Bow Chain in Good Condition.

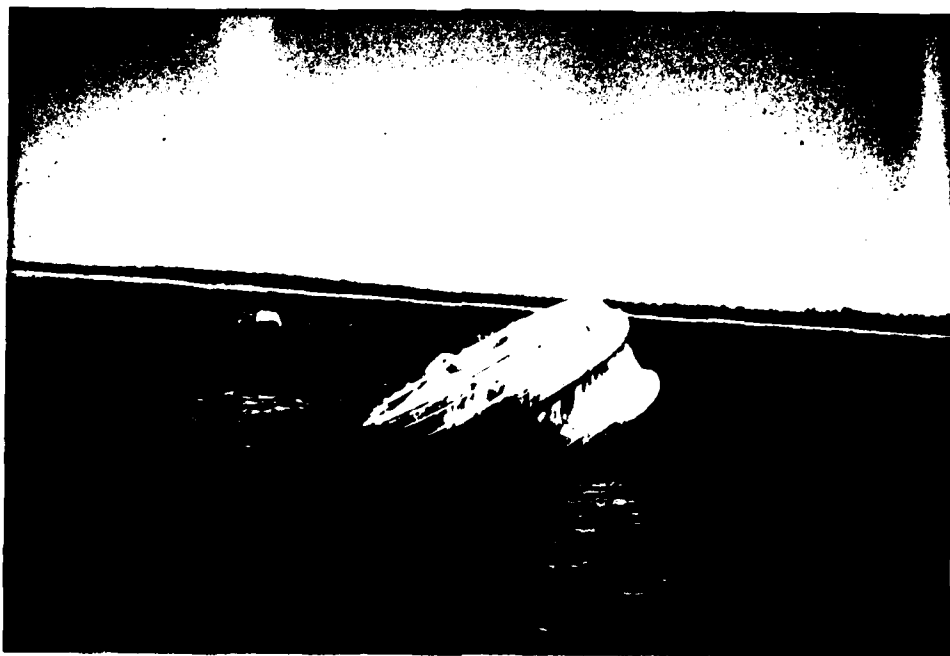

The Auxiliary Mooring Buoy
Showing a Severe List.



ARDM 2- The Position of the Barges
on the Starboard Side.

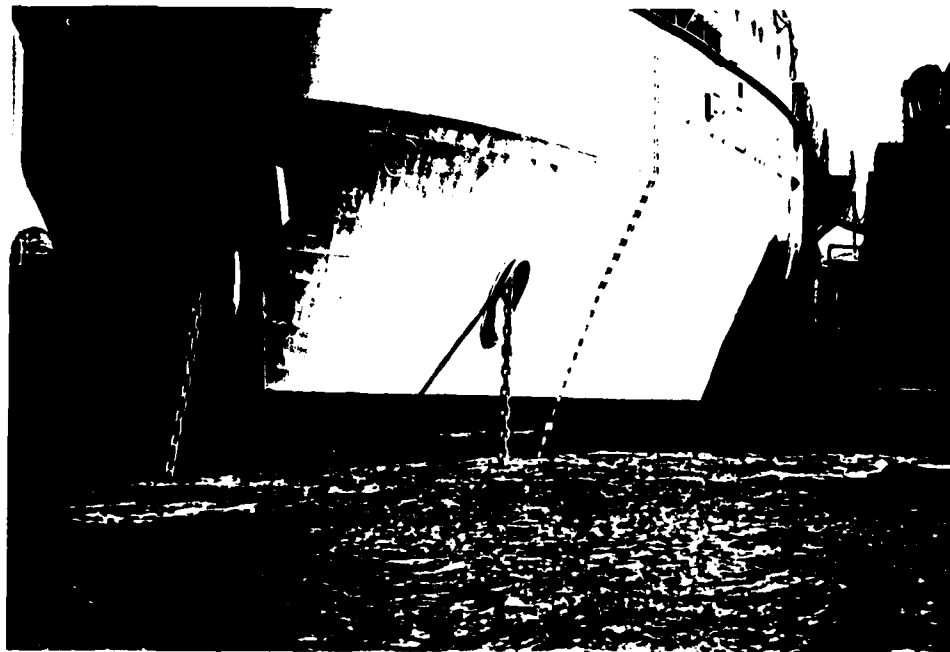

ARDM 2 Bow Chains in
Good Condition.

ANNEX C
SURVEY DATA

SURVEY OF THE NAVAL WEAPONS STATION CHARLESTON

A survey of the three moorings maintained by WPNSTA Charleston was conducted on 1-5 April 1985. This Annex contains the data gathered to determine the positions of each of the three moorings. Figure C-1 depicts the locations of the three moorings and two ashore sites used during the survey.

Description of Alpha: Alpha is located 3 feet 2-5/8 inches from the pier edge near the port stern mooring leg of the tender on Pier C. Alpha is the intersection of lines C, B, and D which can be found on Figure C-2.

Description of Bravo: Bravo is located in the woods south southwest of Pier C. One can see a sign from the Pier where the point is located. The point is a manhole cover to a sewer outlet about 10 yards past a fire hydrant on a dirt road. See Figure C-1 and C-3 for location of this point.

Description of Benchmark Pier-C: This benchmark is located 15 feet from the start of Pier C along the southern edge. Benchmark Pier-C, or point 1 can be found on Figure C-2.

Description of Benchmark Pier-B: This benchmark is located at the end of Pier B next to the ladder of the Radio Tower. Benchmark Pier-B, or point 3 can be found on Figure C-2.

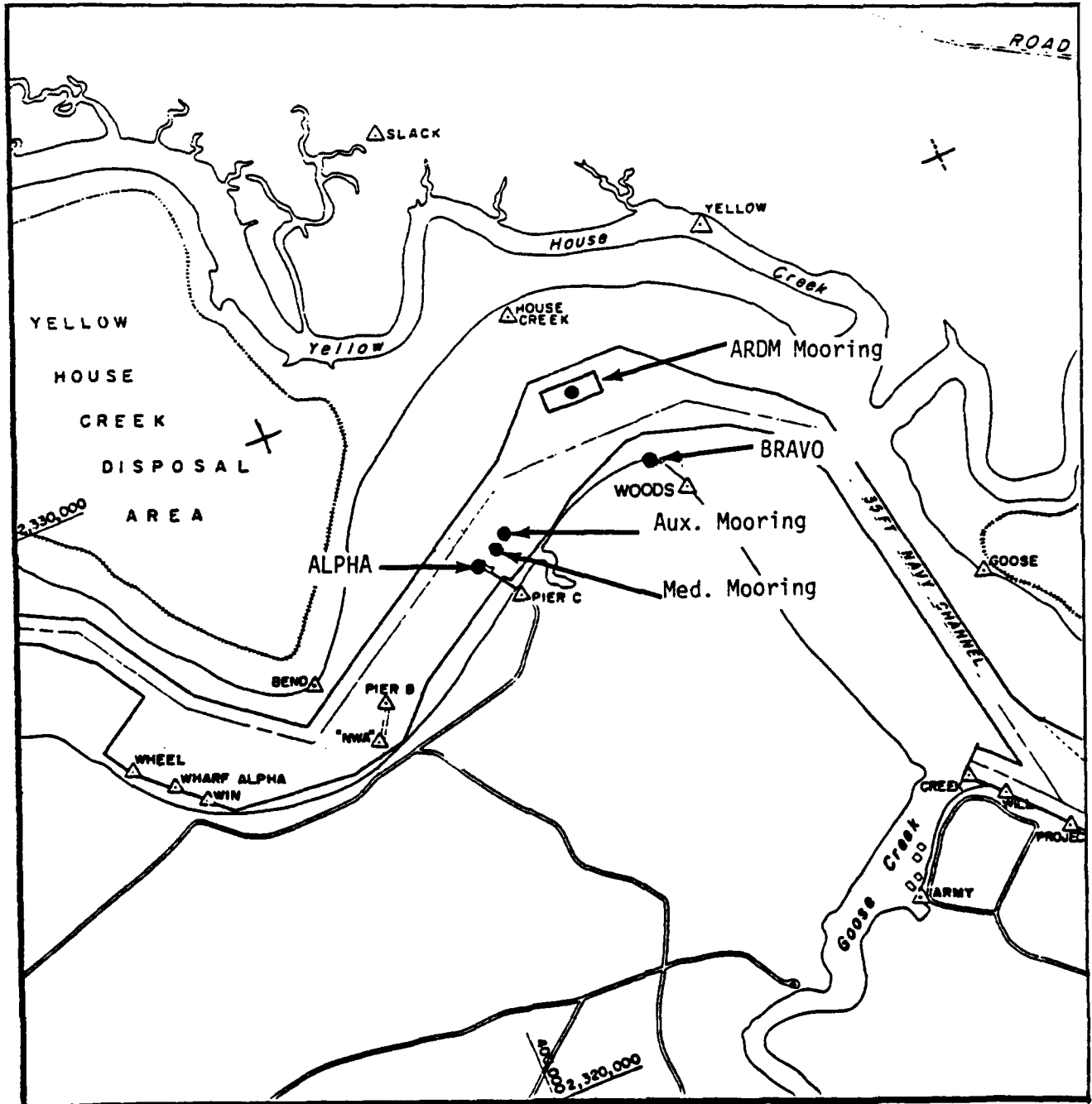

Figure C-1. Primary Survey Sites

MOORING/SURVEY SITE COORDINATES:

| <u>SITE</u> | <u>LATITUDE</u> | <u>LONGITUDE</u> |
|-------------------|-----------------|------------------|
| ALPHA | 32°55' 21.320"N | 79°56' 0.666"E |
| BRAVO | 32°55' 2.014"N | 79°55' 57.176"E |
| ARDM (BOW) | 32°54' 57.329"N | 79°55' 39.688"E |
| ARDM (PORT-STERN) | 32°54' 59.063"N | 79°55' 40.147"E |
| MED (STBD) | 32°55' 14.299"N | 79°55' 57.662"E |
| MED (PORT) | 32°55' 15.276"N | 79°55' 55.100"E |
| AUXILIARY | 32°55' 14.769"N | 79°55' 56.506"E |

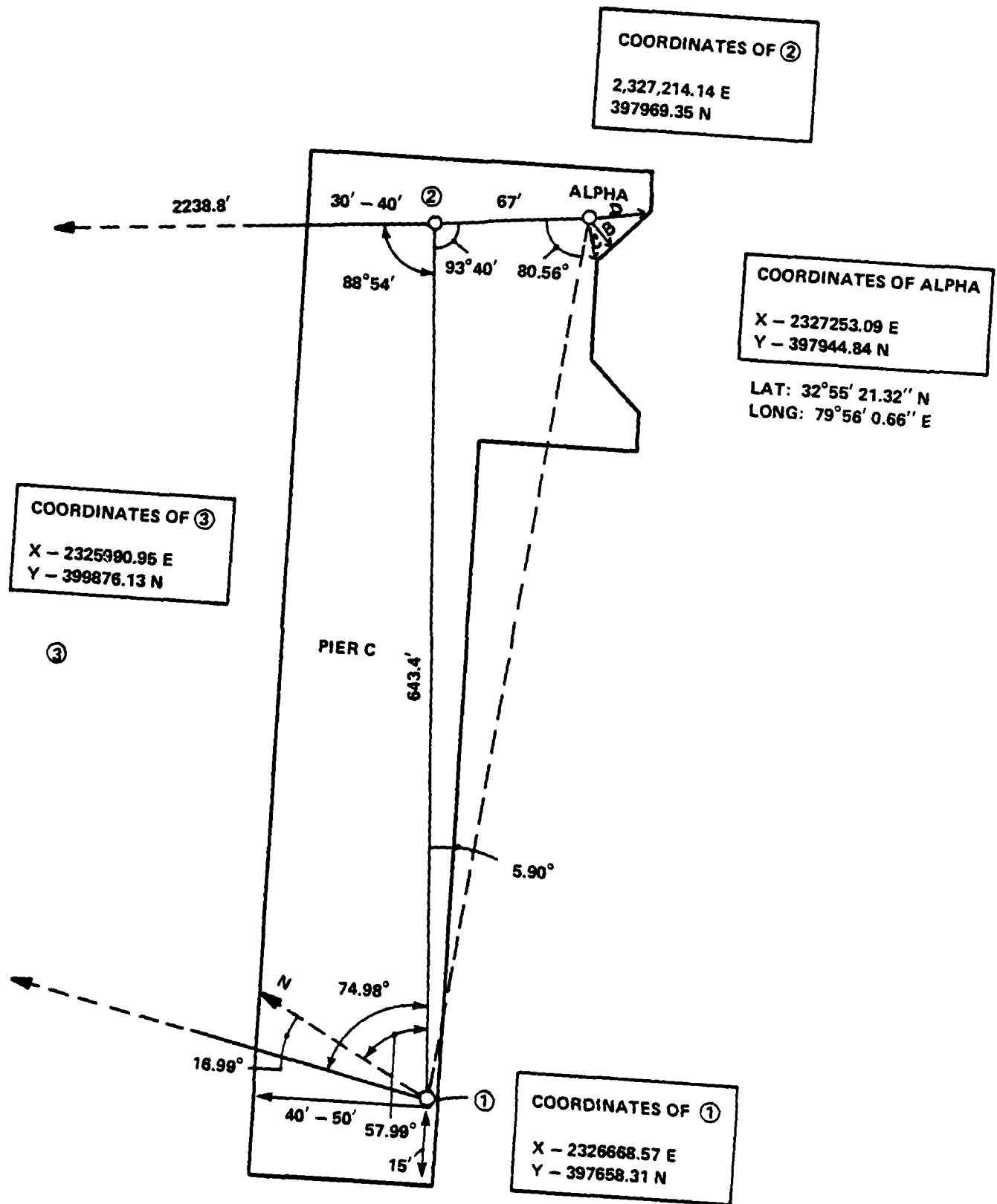
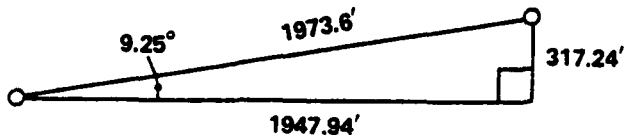
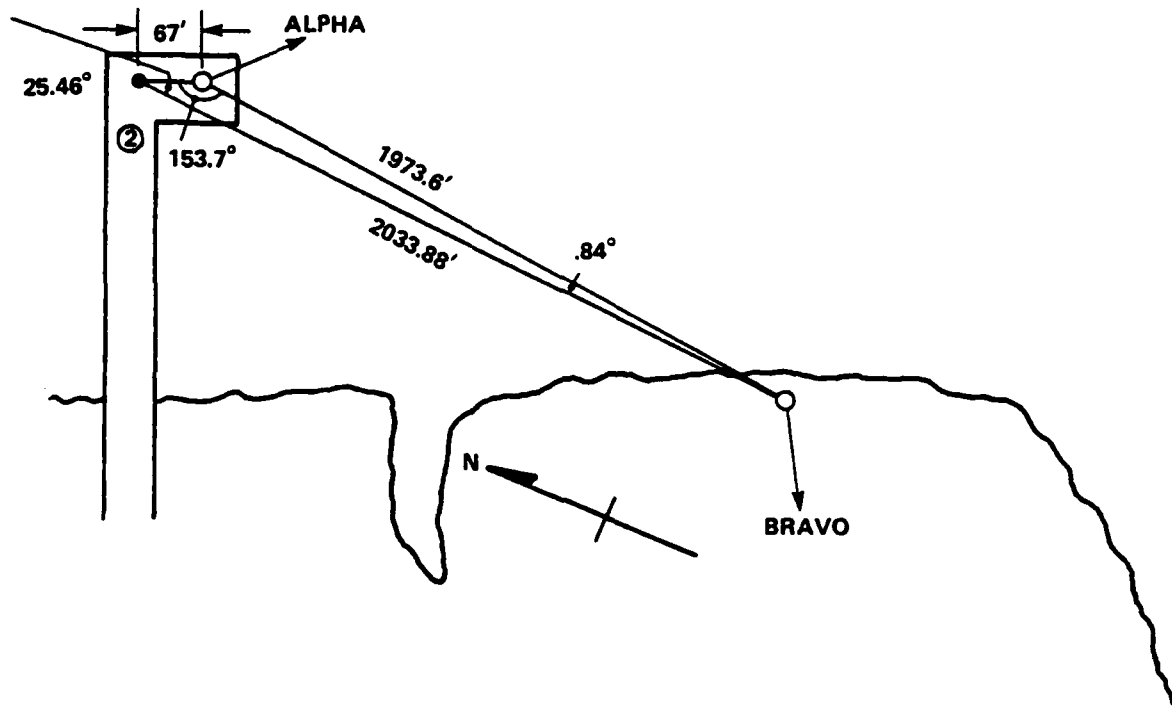

Figure C-2. SURVEY SITE ALPHA ON PIER C.

**BRAVO: FOUND FROM TURNING TRANSIT 153.7°
COUNTERCLOCKWISE FROM ② TO BRAVO**



| |
|--|
| COORDINATES OF BRAVO X - 2327570.33 E Y - 395996.90 N |
|--|

LAT: 32°55' 2.014" N
LONG: 79°55' 57.176" E

Figure C-3. REFERENCE POINTS ALPHA AND BRAVO.

STARBOARD FENDER BUOY: AT ALPHA TURNED TRANSIT 11.17° COUNTERCLOCKWISE
 AT BRAVO TURNED TRANSIT 6.72° COUNTERCLOCKWISE.

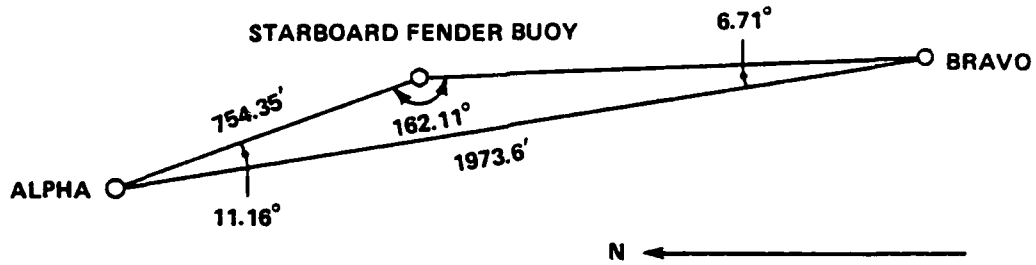

**COORDINATES OF
 STARBOARD FENDER BUOY**
 X - 2327516.25 E
 Y - 397237.88 N

LAT: 32°55' 14.299" N
 LONG: 79°55' 57.662" E

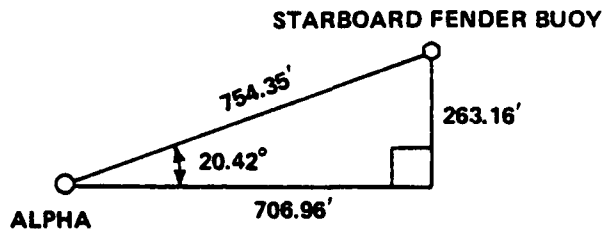

PORT FENDER BUOY: AT ALPHA TURNED TRANSIT 29.17° COUNTERCLOCKWISE
 AT BRAVO TURNED TRANSIT 16.15° CLOCKWISE.

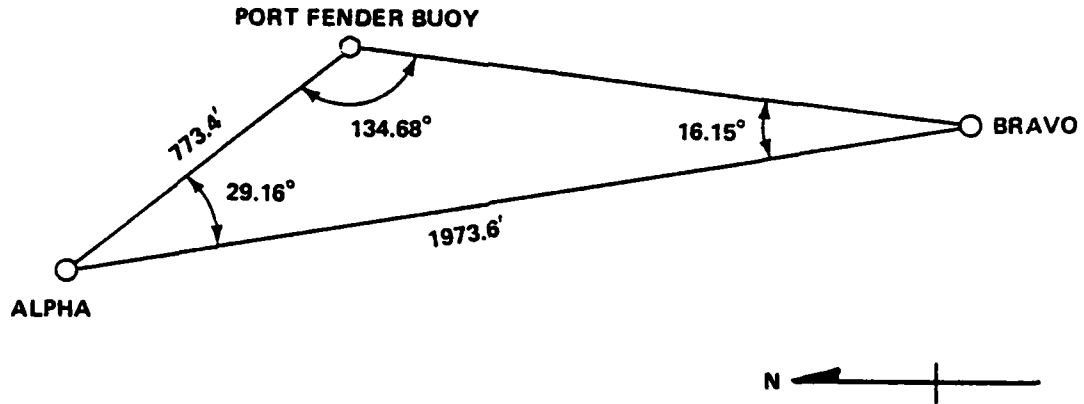

**COORDINATES OF
 PORT FENDER BUOY**
 X - 2327733.67 E
 Y - 397338.87 N

LAT: 32°55' 15.276" N
 LONG: 79°55' 55.100" E

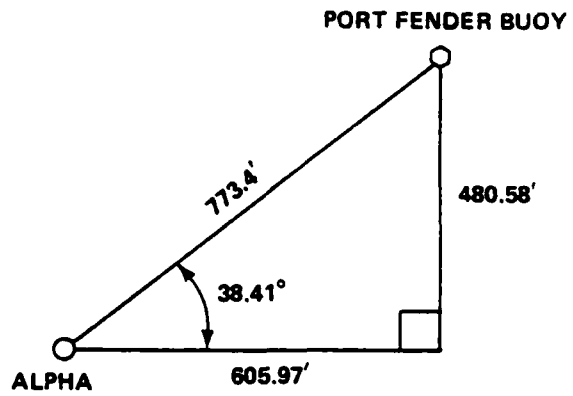

N ←

AUXILIARY BUOY: USING ALPHA TO BRAVO AS THE BASELINE,
 AT ALPHA TURNED TRANSIT 19.5° COUNTERCLOCKWISE
 AND AT BRAVO TURNED TRANSIT 11.17° COUNTER-
 CLOCKWISE.

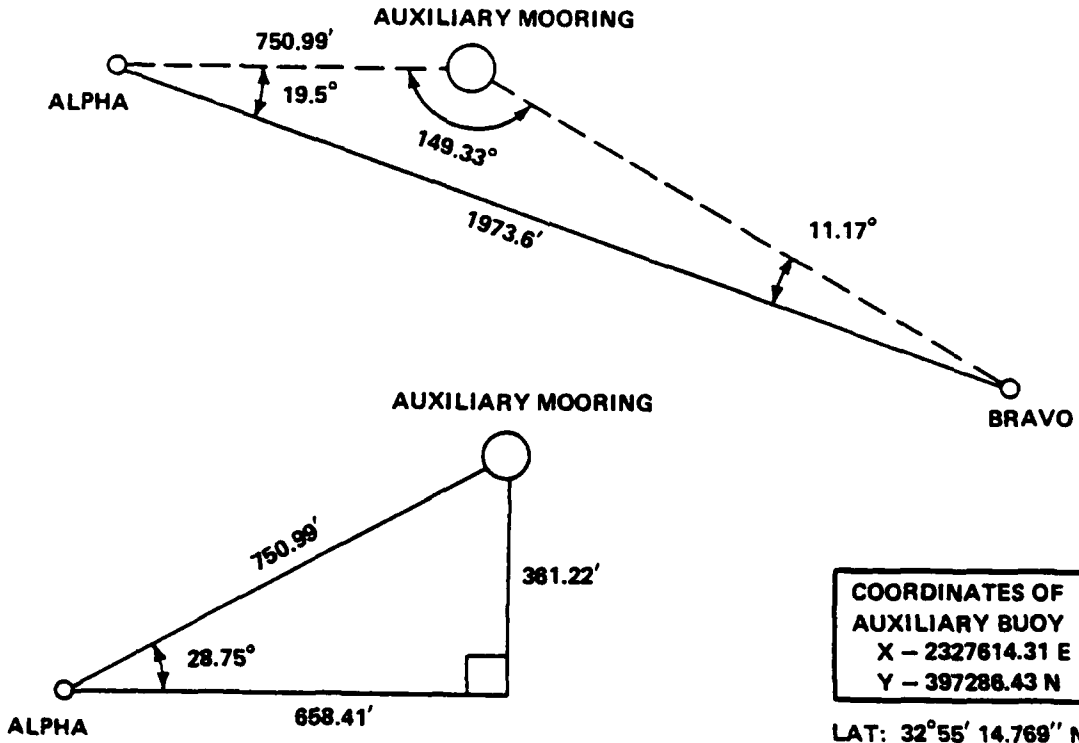

| |
|--|
| COORDINATES OF AUXILIARY BUOY X - 2327614.31 E Y - 397286.43 N |
|--|

LAT: 32°55' 14.769" N
 LONG: 79°55' 56.506" E

BOW OF ARDM: AT ALPHA TURNED TRANSIT 37.60° COUNTERCLOCKWISE.

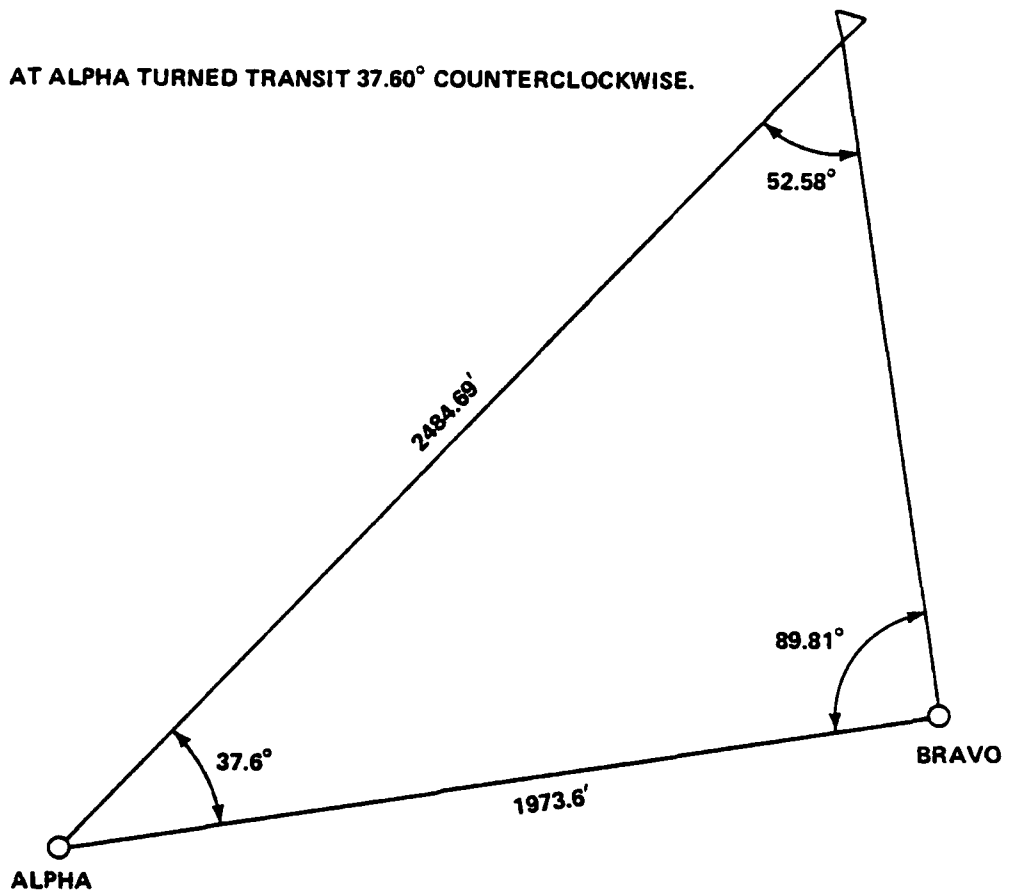

**COORDINATES OF
BOW ARDM**
X - 2329065.83 E
Y - 396245.53 N

LAT: 32°54' 57.329" N
LONG: 79°55' 39.688" E

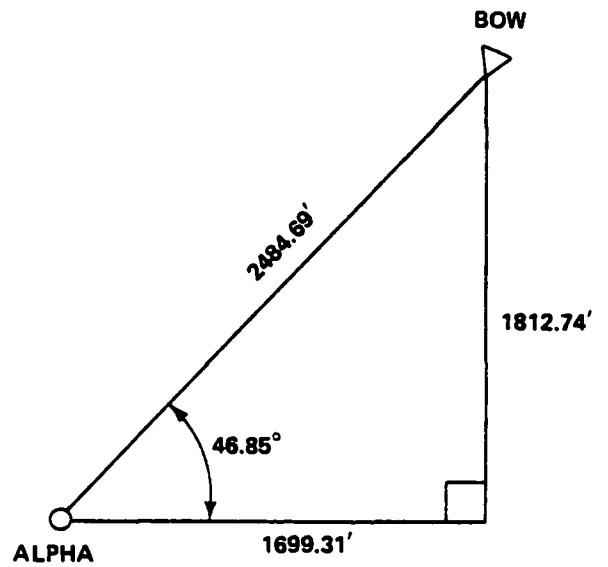

PORT STERN OF ARDM: AT ALPHA TURNED TRANSIT 29.20° COUNTERCLOCKWISE.

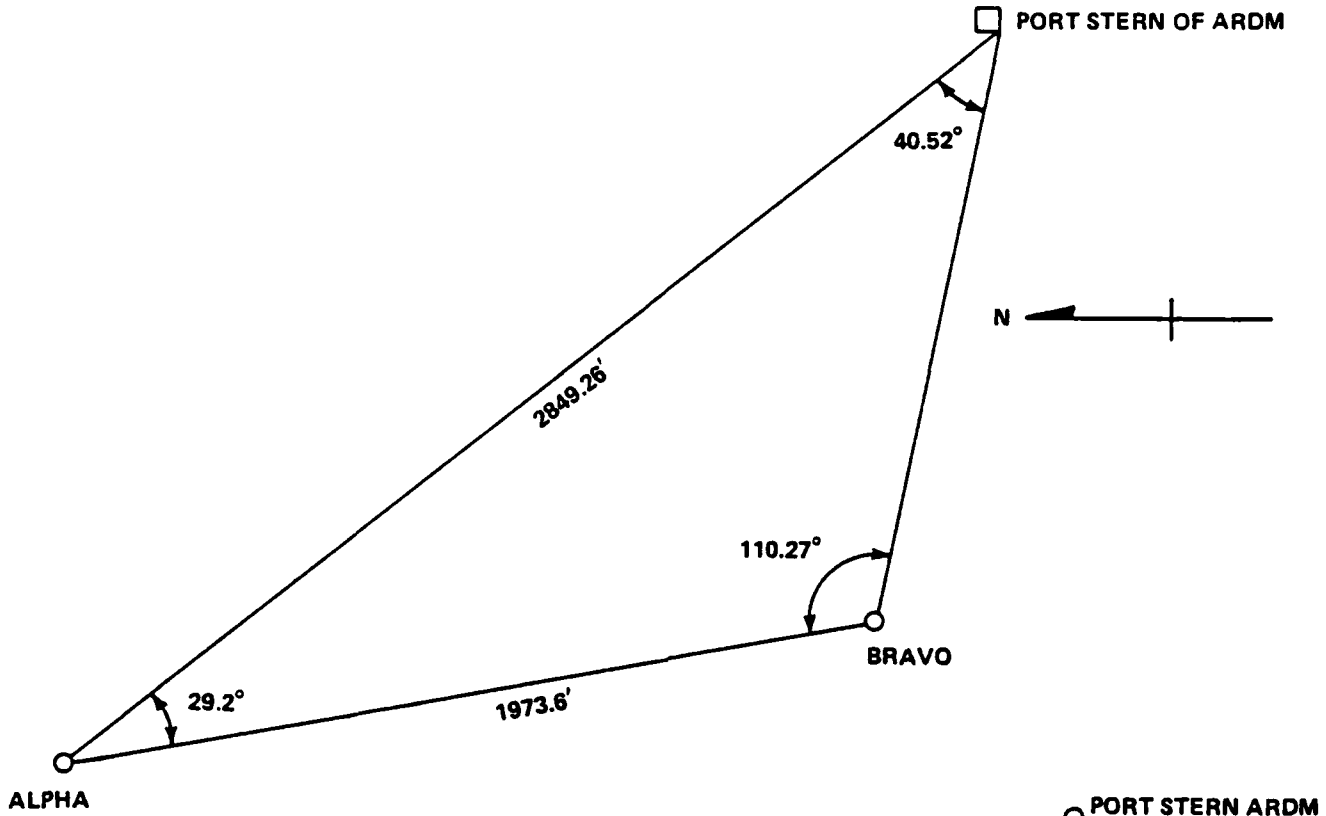

COORDINATES OF
PORT STERN ARDM
X - 2329024.85 E
Y - 395713.44 N

LAT: 32°54' 59.063" N
LONG: 79°55' 40.147" E

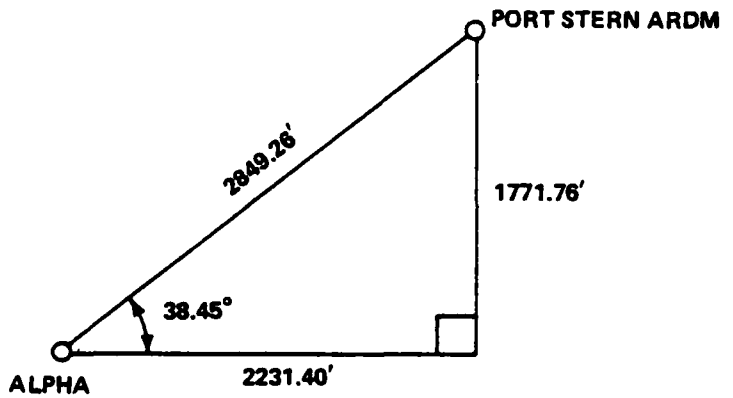

ANNEX D
REFERENCES

Naval Speedletter

X

UNCLASSIFIED

9 May 1985

Craig Pennington, FPO-1PM3
202-433-3881

Commanding Officer
Naval Weapons Station
Charleston, SC 29408

INSTRUCTIONS

1. In order to speed processing, a readily identifiable special window envelope, OPNAV 216-115A, Speedletter Envelope, is provided for unclassified speedletters where bulk mailing is not used. Other window envelopes also may be used. In bulk mail, speedletters should be placed on top of regular correspondence.

STANDARD REFERENCES AND ENCLOSURES IF ANY TEXT AND SIGNATURE BLOCK

SUBJ: FLEET MOORING INSPECTION

1. A CHESDIV/UCT ONE Underwater Inspection of the Fleet Moorings at WPNSTA Charleston was conducted during the period of 1 - 5 Apr 85. The following is a preliminary report of the results.
2. THE Red Mooring, ARDM Mooring, and the chain of the auxiliary mooring are in good condition, with the exception of the first two links of the ARDM's Starboard leg at frame three. These links are between 80 and 90 % of original wire diameter and should be replaced during the next schedule overhaul.
3. Due to its deteriorated state, the auxiliary peg top buoy should be overhauled, if the buoy is to remain in fleet use.
4. A detailed report of the final evaluation of the mooring condition will follow. POC at this Command is C. Pennington at (202) 433-3881 or A/V 288-3881.

Fold

A. M. PARISI
By direction

copy to

CONSUBRON EIGHTEEN
COMNAVFACENGCOM
COMCBLANT

SOUTHNAVFACENGCOM
USS ALAMOGORDO
USS HOLLAND

UCT ONE

FPO-1PM3
FPO-1PM2
FPO-1OP (PDC)

Daily
Route
0161 (2)

From

Commanding Officer
Chesapeake Division
Naval Facilities Engineering Command
Washington, DC 20374-2121

ADDRESS REPLY AS
INDICATED AT LEFT OR REFER
TO PERSON AND NUMBER

unclassified

END

Dtjic

7-86