

MICROCOPY

CHART

FPO  
8507

FPO-1-85 (7)



**SD**  
DTIC  
ELECTE  
JUN 16 1985  
D

AD-A168 460



# NAVAL STATION MAYPORT PROJECT EXECUTION PLAN

APRIL 1985

OCEAN ENGINEERING  
AND CONSTRUCTION PROJECT OFFICE  
CHESAPEAKE DIVISION  
NAVAL FACILITIES ENGINEERING COMMAND  
WASHINGTON, DC 20374

ENC. FILE COPY

**DISTRIBUTION STATEMENT A**  
Approved for public release  
Distribution Unlimited

86 6 12 143

ADA 168460

Unclassified  
SECURITY CLASSIFICATION OF THIS PAGE

REPORT DOCUMENTATION PAGE

1a. REPORT SECURITY CLASSIFICATION  
Unclassified

1b. RESTRICTIVE MARKINGS

2a. SECURITY CLASSIFICATION AUTHORITY

3. DISTRIBUTION AVAILABILITY OF REP.  
Approved for public release;  
distribution is unlimited

2b. DECLASSIFICATION/DOWNGRADING SCHEDULE

4. PERFORMING ORGANIZATION REPORT NUMBER

5. MONITORING ORGANIZATION REPORT #  
FPO-1-85(7)

6a. NAME OF PERFORM. ORG.  
Ocean Engineering  
& Construction  
Project Office  
CHESNAVFACENGCOM

6b. OFFICE SYM

7a. NAME OF MONITORING ORGANIZATION

6c. ADDRESS (City, State, and Zip Code)  
BLDG. 212, Washington Navy Yard  
Washington, D.C. 20374-2121

7b. ADDRESS (City, State, and Zip )

8a. NAME OF FUNDING ORG.

8b. OFFICE SYM

9. PROCUREMENT INSTRUMENT INDENT #

8c. ADDRESS (City, State & Zip)

10. SOURCE OF FUNDING NUMBERS

PROGRAM ELEMENT #	PROJECT #	TASK #	WORK UNIT ACCESS #

11. TITLE (Including Security Classification)  
Naval Station Mayport Project Execution Plan

12. PERSONAL AUTHOR(S)

13a. TYPE OF REPORT

13b. TIME COVERED  
FROM TO

14. DATE OF REP. (YYMMDD) 15. PAGES  
85-04 54

16. SUPPLEMENTARY NOTATION

17. COSATI CODES		
FIELD	GROUP	SUB-GROUP

18. SUBJECT TERMS (Continue on reverse if nec.)  
Naval Station Mayport, Mooring installation  
Fleet moorings, Mayport, FL

19. ABSTRACT (Continue on reverse if necessary & identify by block number)  
Commencing in early April 1985, the Southern Division, Naval Facilities Engineering Command (SOUTHNAVFACENGCOM) will undertake the installation of three fleet moorings about eight miles west of the Naval Station (NAVSTA) Mayport, Florida in the St. Johns River. These will be free-swinging (Con't)

20. DISTRIBUTION/AVAILABILITY OF ABSTRACT  
SAME AS RPT.

21. ABSTRACT SECURITY CLASSIFICATION

22a. NAME OF RESPONSIBLE INDIVIDUAL  
Jacqueline B. Riley  
DD FORM 1473, 84MAR

22b. TELEPHONE 22c. OFFICE SYMBOL  
202-433-3881

SECURITY CLASSIFICATION OF THIS PAGE

BLOCK 19 (Con't)

hurricane type moorings to be used to moor YD, YC, barges, and other harbor craft.

This execution plan has been developed to establish the responsibilities of participating organizations and to provide guidelines/procedures to be followed during the accomplishment of this project. This plan includes mooring description and a bill of materials; installation procedures; the personnel skills, material, and equipment required to successfully complete the installation; and the post installation testing and inspection requirements.

## TABLE OF CONTENTS

<u>Section</u>	<u>Page</u>
1.0 GENERAL	1
1.1 Background	1
1.2 Organizational Responsibilities	1
1.2.1 SOUTHNAVFACENGCOM Responsibilities	2
1.2.2 CHESNAVFACENGCOM Responsibilities	2
1.2.3 NAVSTA Mayport Responsibilities	4
1.2.4 UCT ONE Responsibilities	5
1.2.5 NAS Jacksonville Responsibilities	6
1.2.6 Contractor (Tracor Marine) Responsibilities	6
1.3 Safety (General)	6
1.3.1 Safety Responsibility	7
1.3.2 Personal Safety Equipment	8
1.4 Project Site	8
1.5 Site Survey	8
1.5.1 Monument Coordinates	8
1.5.2 Buoy Coordinates	12
1.5.3 Baselines	12
1.6 Mooring Description	13
1.7 Marker Buoy Coordinates	14
2.0 INSTALLATION PROCEDURES	16
2.1 Installation of Marker Buoys	16
2.2 Preinstallation Inspection	16

2.3	Installation Procedures	21
2.4	Pull Test Procedures	27
2.4.1	Rigging the Crane Barge for a Pull Test	27
2.4.2	Pull Test Requirements	27
2.4.3	Test Procedures	29
2.5	Continued Installation Procedures	31
2.6	Watch Circle Pull Test	34

**ANNEX**

A	Material Requirements	A-1
B	Use of the Underwater Voltmeter	B-1
C	Kenter Joining Link Assembly Procedures	C-1

Accession For	
NTIS CRA&I	<input checked="" type="checkbox"/>
DTIC TAB	<input type="checkbox"/>
Unannounced	<input type="checkbox"/>
Justification	
By	
Distribution/	
Availability Codes	
Dist	Avail and/or Special
A-1	



NAVAL STATION MAYPORT  
PROJECT EXECUTION PLAN

1.0 GENERAL

1.1 Background. Commencing in early April 1985, the Southern Division, Naval Facilities Engineering Command (SOUTHNAVFACENGCOM) will undertake the installation of three fleet moorings about eight miles west of the Naval Station (NAVSTA) Mayport, Florida in the St. Johns River. These will be free-swinging hurricane type moorings to be used to moor YD, YC, barges, and other harbor craft.

This execution plan has been developed to establish the responsibilities of participating organizations and to provide guidelines/procedures to be followed during the accomplishment of this project. This plan includes mooring description and a bill of materials; installation procedures; the personnel skills, material, and equipment required to successfully complete the installation; and the post installation testing and inspection requirements. *NAVSTA Mayport*

1.2 Organization Responsibilities. The major activities involved in this project are:

SOUTHNAVFACENGCOM

CHESNAVFACENGCOM

NAVSTA Mayport

Underwater Construction Team One

NAS Jacksonville

Tracor Marine (Contractor)

The responsibilities of these activities are as follows:

1.2.1 SOUTHNAVFACENGCOM Responsibilities

- a. Provide financial support
- b. Develop requirements and criteria
- c. Liaison between all activities involved
- d. Provide three refurbished mooring buoys

1.2.2 CHESNAVFACENGCOM Responsibilities

- a. Develop a Project Execution Plan (PEP) to coordinate the efforts required to install the three hurricane moorings.
- b. With the assistance of NAVSTA Mayport personnel, establish the criteria for the desired geographical location of each of the three mooring buoys. Determine the benchmarks, backsights, and landmarks to be utilized in establishing and verifying the accurate positioning of the buoy locations selected. Ensure that the fixed ashore positions to be utilized in the site survey can be located and properly identified.

- c. Provide overall management functions such as project supervision, the tracking of project finances, the obtaining of construction permits, the acquisition of mooring material, and the coordination of participating activities.
- d. Provide on-site engineers to direct and supervise the mooring installations, to ensure proper fit of mooring material, to document the "as-built" configuration of each mooring, to supervise required pull tests, and to document post-installation inspection diver findings.
- e. Procure and deliver to NAVSTA Mayport seventeen 250 pound zinc anodes for installation on the anchor leg subassemblies.
- f. Provide, from the Ocean Construction Equipment Inventory (OCEI), equipment or material that may be required to support the installation effort (see Annex A).
- g. Ensure that the dates and times of the installation operations are promulgated in a "Notice to Mariners," and that, when installed, the appropriate navigational charts are changed to reflect the positions of the three new moorings.
- h. Prepare and distribute to all interested activities a Project Documentation Report which will include project background; a general description of the moorings installed; an overview of the installation procedures; and drawings, photographs, schematics, and written

documentation of the detailed "as-built" configuration of each mooring. Any deviations from the original engineering design drawings will also be detailed in this report.

### 1.2.3 Naval Station Mayport Responsibilities

- a. Provide a Mike Boat or Whaler (with an operator) for one day to support the mooring site survey (Date TBD).
- b. Assist CHESNAVFACENCOM in establishing the desired geographical positions of the moorings and in locating and identifying required ashore benchmarks, landmarks, and backsights for fixing the desired positions.
- c. Provide a Mike Boat or Whaler (without an operator) for an estimated three weeks during the installation operations during the April/May time frame.
- d. Provide a crane and flat-bed truck (with operators) for one day to remove material stored at Blount Island (Date TBD).
- e. Provide a YC for three weeks during the April/May installation time frame.
- f. Provide a portable welder for three weeks during the April/May installation time frame.

g. Provide a YTB for two days during the installation period, the first day, to move the YC (during mobilization) to the installation site, and the second to return the YC (during demobilization) to its normal berth.

h. Provide a fenced storage area for mooring material and equipment inventories from the arrival of the first shipment of material until the installation demobilization has been completed.

1.2.4 Underwater Construction Team One (UCT ONE) Responsibilities

a. Provide diving and rigging support during the installation of the moorings and diver support for the post-installation inspections.

b. Provide special material and equipment that may be required for the mooring installation (see Annex A).

c. Provide qualified personnel and tested/calibrated equipment required to support site survey operations (see Annex A).

d. Provide a small maneuverable boat or utility craft which can be used to assist in the installation and post-installation inspections when required.

- e. Take underwater voltmeter readings to determine the adequacy of the cathodic protection systems after their installation on the sub-assemblies of the three moorings.

#### 1.2.5 Naval Air Station Jacksonville Responsibilities

- a. Receive twelve 25 KIP Navy Stockless Anchors (with stabilizers) which will be shipped by rail to NAS Jacksonville from the Navy Construction Battalion Center (NCBC) Davisville, Rhode Island.
- b. Store these anchors until they are required for the mooring installations.

#### 1.2.6 Contractor (Tracor Marine) Responsibilities

- a. Provide a 150 x 45 foot barge, a 100 ton crawler crane, and a 100KIP winch. Have this equipment available and ready for use at the installation site in time for mobilization.
- b. Provide personnel experienced in rigging and mooring installations to support the Project and to conduct liaison between sub-contractors and other on-site personnel.

1.3 Safety (General). This project shall be conducted in such a manner that established safety standards, practices, and regulations are followed. It shall be the responsibility of each individual assigned to the project

to practice safety during all assigned tasks and to report promptly to the cognizant authority unsafe conditions or practices noted.

1.3.1 Safety Responsibility. Each activity assigned to this project is responsible for the safety of its personnel. In addition, specific activities are responsible for general area of safety as follows:

COGNIZANT ACTIVITY

AREA OF RESPONSIBILITY

UCT ONE

All diving operations and diving safety, including the decision to dive or not, depending on weather or questionable site conditions.

NAVSTA Mayport

Promulgation of a "Notice to Mariners" concerning the project effort when the installation is in progress.

Ensure that all Navy vessels and yard craft involved in the project display the appropriate shapes and lights for vessels engaged in inland underwater operations.

Contractor (Tracor Marine)

Safe operation of all project vessels crewed by contractor personnel.

1.3.2 Personal Safety Equipment. All regulations concerning the use of personal safety equipment (i.e. life jackets, work vests, safety shoes, etc.) shall be complied with.

1.4 Project Site. This fleet mooring installation project will be accomplished in the St. Johns River about eight miles west of NAVSTA Mayport. Figure 1-1 is a chart of the Jacksonville/Mayport area while Figure 1-2 details that area of the St. Johns River that has been selected for the mooring installations.

1.5 Site Survey. The following information consists of proposed buoy and current monument locations (see Figure 1-3), coordinates, and calculations of baselines with angles and bearings to the proposed buoy locations.

1.5.1 Monument Coordinates

<u>Monument</u>	<u>Plane Coordinates</u>	
	X	Y
SM1-1 (75)	329,616.22	2,209,936.63
SM1-2	329,027.77	2,210,415.54
STJO 224	328,047.86	2,209,509.27
14	329,083.44	2,210,240.46





x = 330,000

SCALE IN FEET

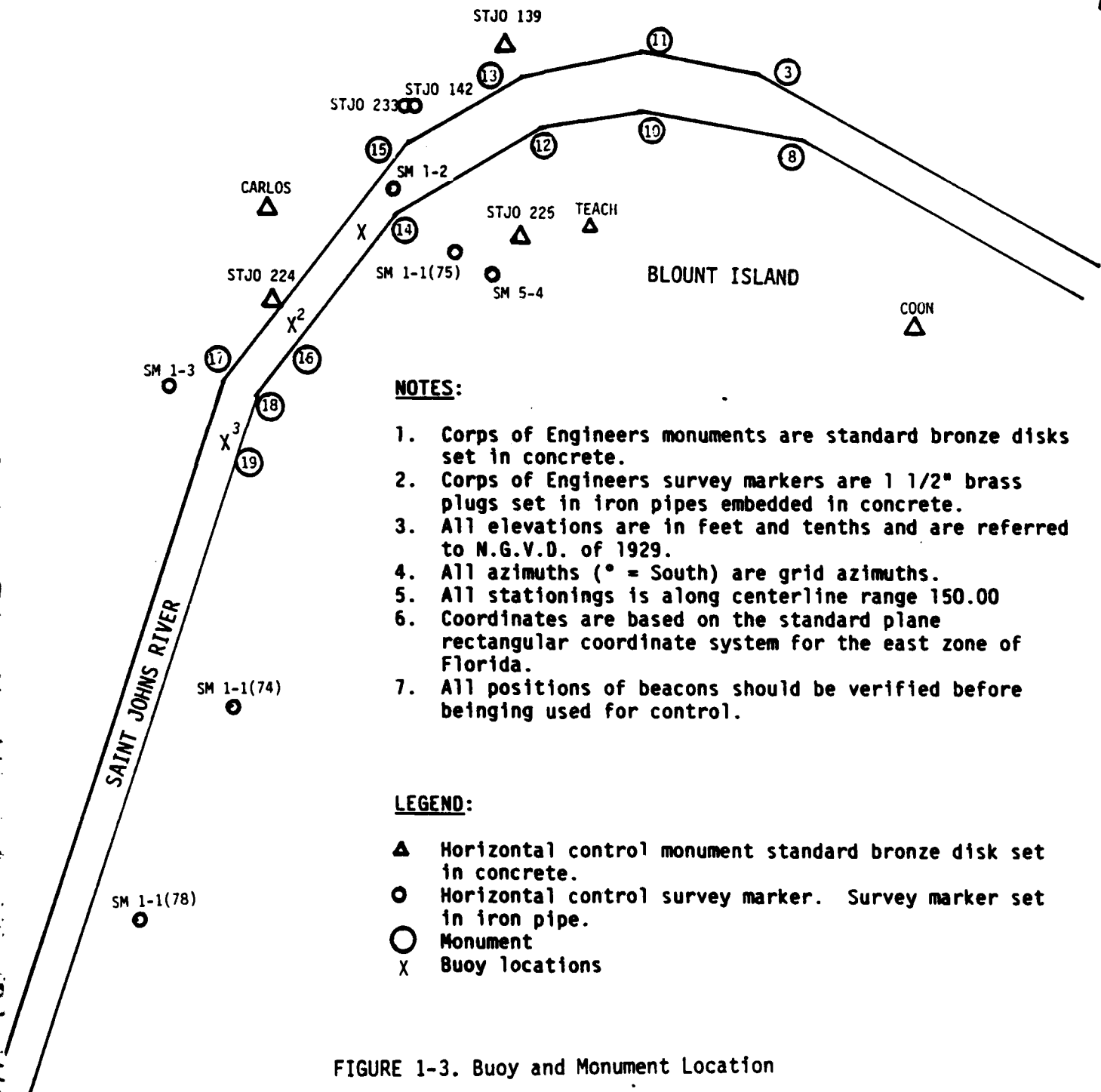
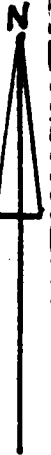

**NOTES:**

1. Corps of Engineers monuments are standard bronze disks set in concrete.
2. Corps of Engineers survey markers are 1 1/2" brass plugs set in iron pipes embedded in concrete.
3. All elevations are in feet and tenths and are referred to N.G.V.D. of 1929.
4. All azimuths ( $^{\circ}$  = South) are grid azimuths.
5. All stationings is along centerline range 150.00
6. Coordinates are based on the standard plane rectangular coordinate system for the east zone of Florida.
7. All positions of beacons should be verified before being used for control.

**LEGEND:**

- ▲ Horizontal control monument standard bronze disk set in concrete.
- Horizontal control survey marker. Survey marker set in iron pipe.
- Monument
- X Buoy locations

FIGURE 1-3. Buoy and Monument Location

Monument

Plane Coordinates

	X	Y
16	328,263.31	2,209,137.07
18	327,920.72	2,208,676.15
19	327,751.11	2,208,127.46
17	327,649.28	2,208,813.85

1.5.2 Buoy Coordinates

Buoy

Coordinates

No. 1 (North)	N 2,209,370 Ft.
	E 327,830 Ft.
No. 2 (Central)	N 2,208,540 Ft.
	E 328,200 Ft.
No. 3 (South)	N 2,207,570 Ft.
	E 328,720 Ft.

1.5.3 Baselines

- 16 to SM1-2
- 16 to 14
- 14 to 19
- 19 to 18 (for Buoy 3)
- STJO 224 to SM1-2
- 17 to 18

Baseline		Buoy	Angle	Angle	Bearing	Bearing	Bearing
1	2		1	2	1-2	2-3	1-3
16	14	#1	98° 21' 43"	18° 35' 56"	36° 37' 22"	55° 13' 18"	118° 15' 38"
		#2	149° 25' 47"	9° 10' 10"	36° 37' 22"	45° 47' 32"	67° 11' 34"
		#3	127° 7' 46"	28° 52' 21"	36° 37' 22"	65° 29' 43"	90° 30' 25"
16	SM1-2	#1	92° 36' 59"	18° 0' 17"	30° 52' 38"	48° 52' 56"	118° 15' 38"
		#2	155° 10' 32"	07° 03' 47"	30° 52' 38"	37° 56' 25"	55° 42' 06"
		#3	132° 52' 30"	24° 42' 15"	30° 52' 38"	06° 10' 23"	163° 45' 08"
19	14	#1	28° 36' 6"	22° 59' 19"	32° 13' 59"	55° 13' 18"	03° 37' 58"
		#2	15° 10' 59"	04° 46' 47"	32° 13' 59"	37° 0' 46"	17° 02' 59"
		#3	87° 40' 53"	24° 28' 59"	32° 13' 59"	56° 42' 57"	-55° 26' 54"
19	18	#3	117° 15' 38"	0° 0' 09"	0° 0' 03"	+179° 59' 59"	+117° 15' 38"
STJO							
224		#1	169° 49' 30"	01° 38' 47"	47° 14' 09"	45° 35' 22"	37° 03' 39"
		#2	123° 50' 37"	23° 25' 17"	47° 14' 09"	23° 48' 51"	171° 04' 46"
		#3	113° 38' 53"	41° 03' 46"	47° 14' 09"	06° 10' 23"	160° 53' 02"
17	18	#1	98° 53' 49"	55° 39' 09"	116° 53' 54"	172° 33' 03"	18° 0' 05"
		#2	0° 27' 33"	179° 05' 28"	116° 53' 54"	115° 59' 22"	116° 26' 21"
		#3	22° 22' 46"	152° 44' 58"	116° 53' 54"	144° 08' 56"	139° 16' 40"

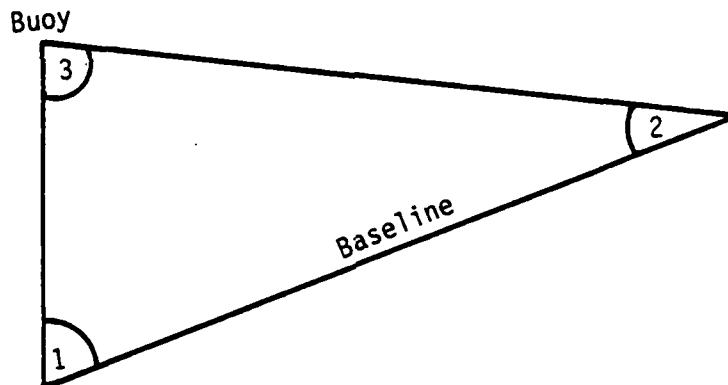

1.6 Mooring Description. Three hurricane moorings will be installed on the northwest side of Blount Island in the St. Johns River. The Florida State plane coordinate grid positions are N2,209370; E327.830, N2,208540; E328,200, and N2,207570; E328,720. Each mooring consists of a riser type drum buoy, a riser chain subassembly, a ground ring, a sinker and four

anchor chain subassemblies with 25KIP Navy Stockless anchors with stabilizers. The chain assemblies are cathodically protected with zinc anodes and wire rope continuity cable systems. See Figure 1-4 for the drawing and description of the hardware.

The four legs of each mooring will be installed on 045, 135, 225, and 315 degree magnetic bearings from their center marker buoy. The length from the base of the center marker buoy to its anchor shackle will be 255 feet. Each anchor chain subassembly will be consecutively numbered (1, 2, 3, and 4) clockwise from magnetic north.

- 1.7 Marker Buoy Coordinates Coordinates of the ring and center marker buoys will be identified in an addendum attached to this PEP.

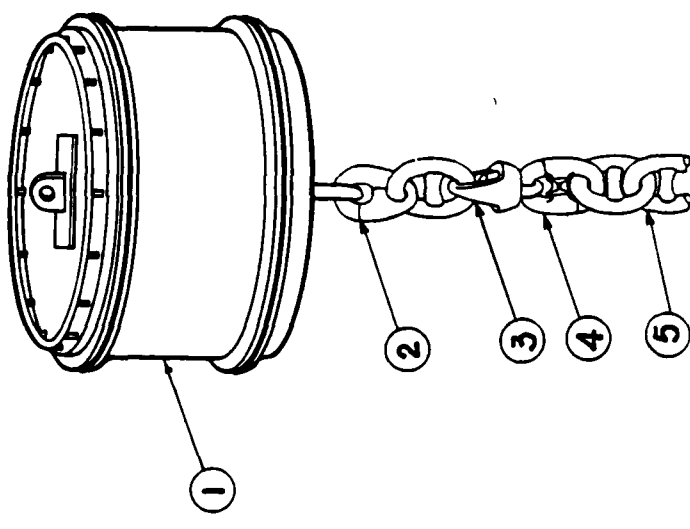

ITEM NO	DESCRIPTION	SIZE	NO REQD	MATERIAL
1	Buoy, Riser-Type Drum	9' dia	3	Steel with Urethane coating
2	Anchor Joining Link	2"	24	Steel
3	Swivel	2"	15	Steel
4	Kenter Chain Joining Link	2"	39	Steel
5	Chain Shots	2"	37 1/2	Steel
6	Ground Ring	2"	3	Steel
7	Chain Joining Link	2 1/4"	12	Steel
8	Anchor Joining Link	2 1/2"	12	Steel
9	Sinker Shackles	2"	3	Steel
10	Navy Stockless Anchor	13k	3	Steel
11	Navy Stockless Anchor	25k	12	Steel
12	Anode *	250 lb	15	Zinc

\* Note: Continuity wire is attached to the chain and anode connecting wires with hose clamps.

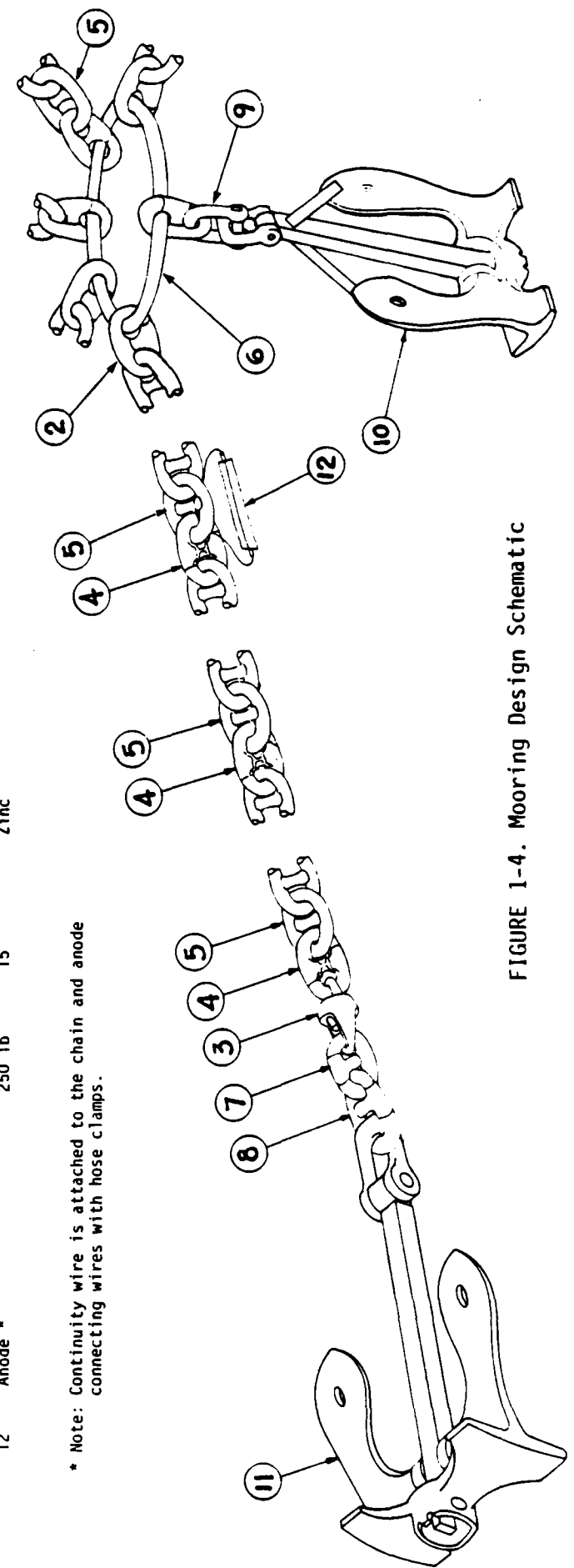

FIGURE 1-4. Mooring Design Schematic

## 2.0 INSTALLATION PROCEDURES

2.1 Installation of Marker Buoys. A center marker buoy will be precisely installed in the geographical position ascertained from the survey. This marker buoy will be about 3 1/2 feet in diameter and weighted so that it floats in an upright position. The buoy will be attached, via wire rope or fiber line, to a light-weight anchor or to a 1,000 pound (or larger) sinker. The line should be sufficiently taut to allow for the maximum predicted tide and yet to restrict the movement of the buoy by providing it only enough line for minimum excursion from the vertical.

After installation of the center marker buoy, four ring marker buoys will be installed to mark the desired positions of the mooring's anchors. Ring marker buoys are relatively small and are maintained in position by a line attached to a 100-pound Navy light-weight anchor or a concrete sinker. These buoys mark the position of the mooring anchors, and provide the bearing from the center marker buoy on which each of the anchor chain subassemblies will be installed. The four ring marker buoys of each mooring will be installed on 045, 135, 225, and 315 degree magnetic bearings from their center marker buoy. The distance between the center marker buoy and each ring marker buoy will be 275 feet. This includes the length of the chain and the length of the anchor plus 10 feet to prevent fouling of the ring marker buoy risers and the anchors. (see Figure 2-1).

2.2 Preinstallation Inspection. An inspection and fit check should be conducted of all mooring assemblies before they leave the storage area.

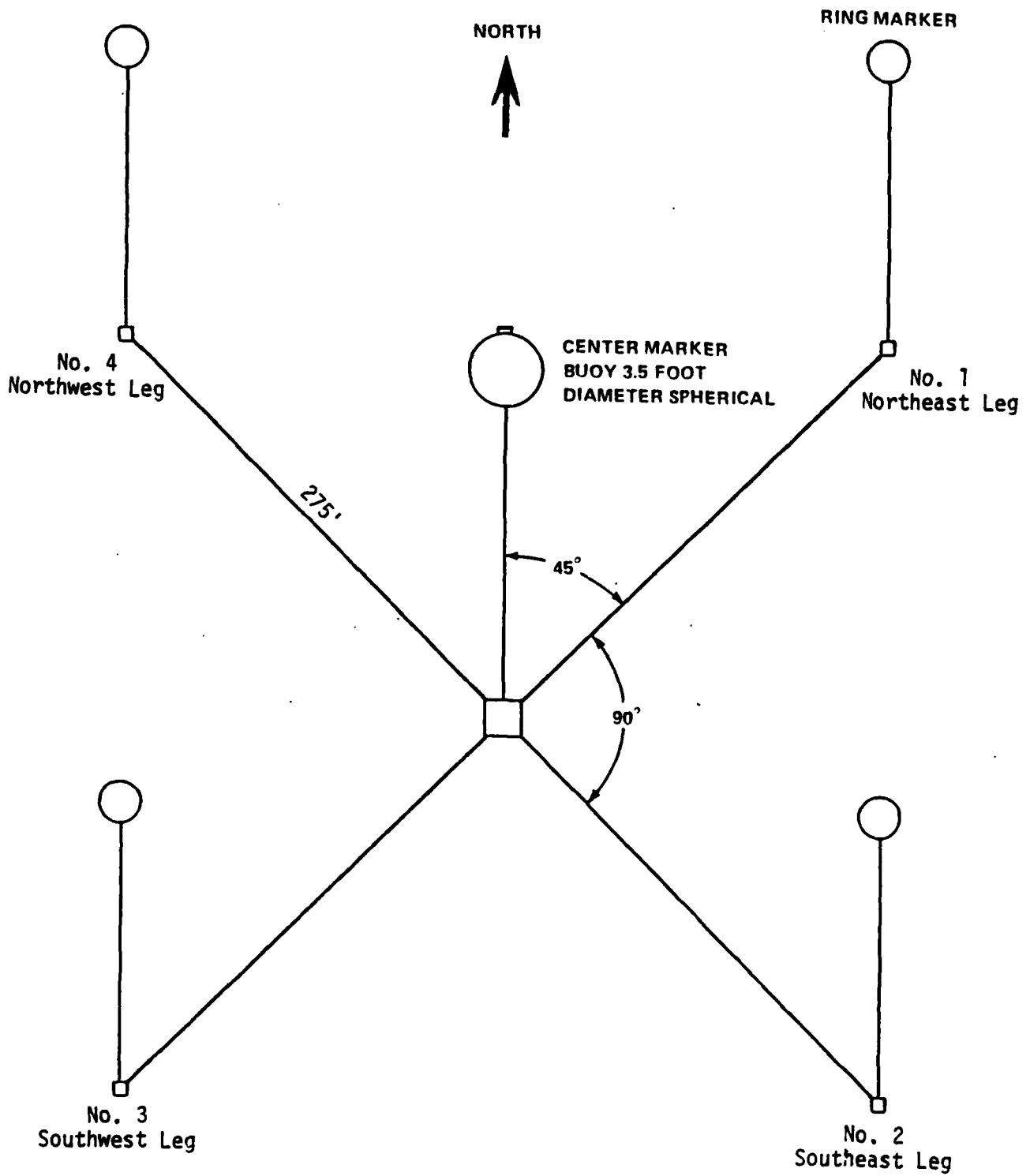

FIGURE 2-1. ANCHOR CHAIN SUBASSEMBLY LAYOUT

A final inspection/check should be conducted as each assembly is laid out on the crane barge deck prior to installation. This will include a check of all chain connections, joining links, and other fittings for proper and secure assembly. The following should receive particular attention:

- o Anchors: Ensure that the flukes are wedged open and welded to an angle of about 50 degrees.

Make up lifting bridles and have a toggle bar release mechanism on hand. (See Figure 2-2).

- o Chain: To be ranged down on deck in rows of six chains 45-foot long (three shots per leg) and 4 tiers high. Two by four-inch wooden battens will separate each tier. All end links are to be accessible and spray-painted white. All material is to be within reach of the crane and free for rousting out. The half shot of riser chain is to be ranged down separately from the anchor chain subassemblies. Continuity wire is clamped to the chain and an anode is connected to the wire at the riser and the first shot of each leg.

- o Connecting Links and Shackles: These will be stored on pallets by size and type. Connecting links will be broken down into individual pieces, the inside slushed with thick oil or covered with grease, and lightly re-assembled.

Care must be exercised that individual pieces of a connecting link are not mixed. The tapered locking pin is to be tried for fit to ensure that the head can be driven into the dovetail recess. Procedures for the assembly of Kenter type joining links are contained in Annex C.

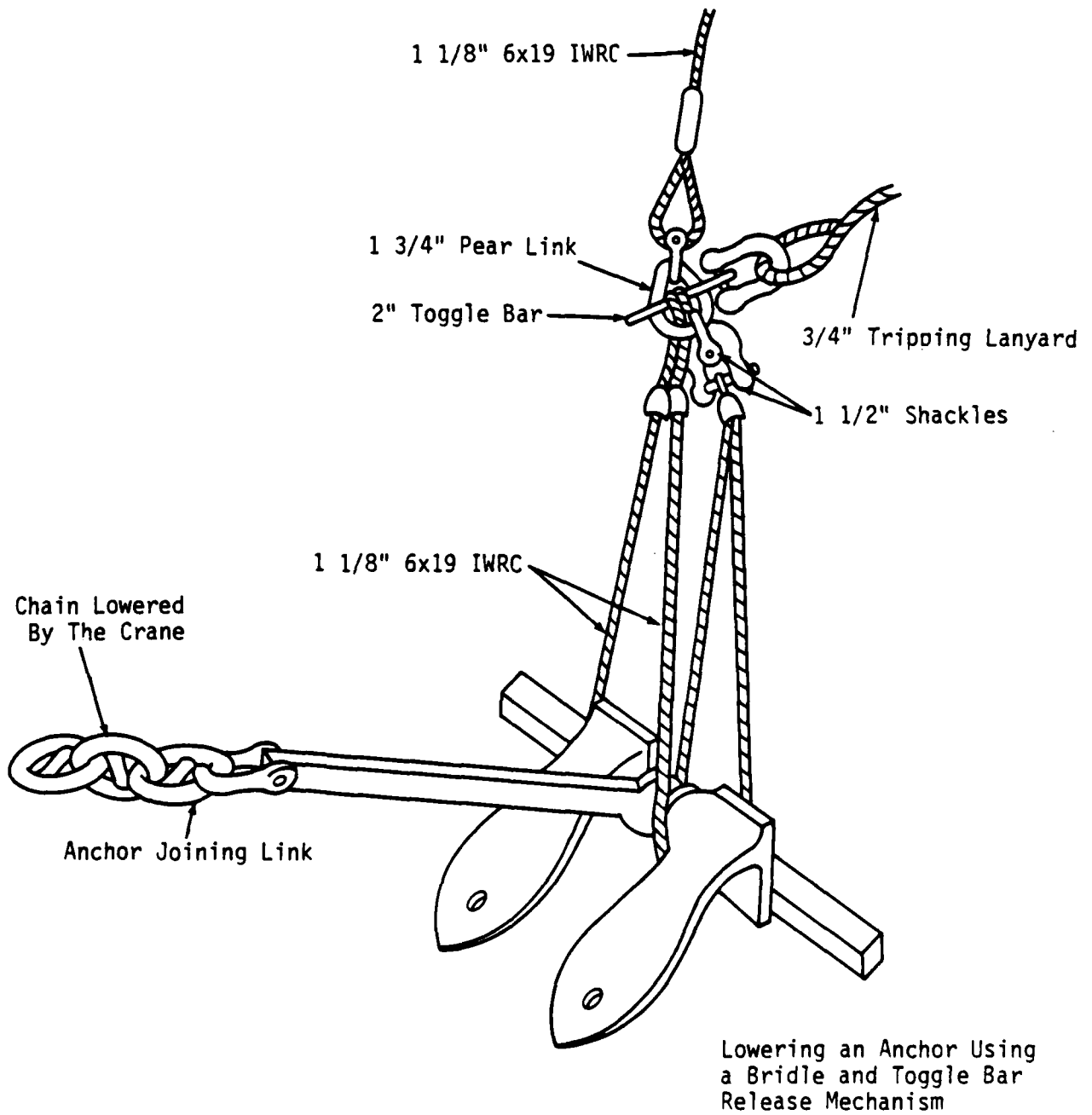

FIGURE 2-2. Lifting Bridle and Release Mechanism

- o Swivel: Check for ease of rotation. Fill the cup with heavy grease. Connect it to the upper end of the riser chain.
  
- o Ground Ring: Have accessible.
  
- o Sinkers: Recheck the fit of the chain and shackles to the hairpin/chain link. Weld the flukes closed on the 13K anchor sinkers.
  
- o Sinker Shackles: Check for fit over 2-inch chain and then have readily available for use.
  
- o Stoppers: Ensure that on-deck padeyes are correctly located, and that the shackle pins fit into the padeye. Ensure that stopper wire ropes are of sufficient length.
  
- o Pelican Hooks: Ensure that they are compatible with 2-inch diameter chain.
  
- o In-Line Dynamometer: Check for a current calibration certificate.
  
- o Return/Snatch Blocks: Check for alignment with their designated padeyes.
  
- o Winch: Welded/bolted down to deck and operable. Fueled and run prior to departing for the installation site.

- o Crane: Check that the turnbuckles are tight and that an even strain is taken all around. Outriggers should be extended to their fullest length, and additional wooden blocks should be placed under each jacking foot to improve the weight distribution on dock.
  
- o Preinstallation Layout: Components for one complete mooring will be laid out on the crane barge and the components for two other moorings loaded on the YC prior to moving off to the mooring site (see Figure 2-3). The mooring should be assembled on the crane barge deck to the maximum extent possible to minimize assembly time on the installation site.

### 2.3 Installation Procedures

1. The first anchor, slung by a bridle in a horizontal position, is lifted (with one shot of chain attached) by the crane. (Two steel bars should have been previously welded to keep the flukes open at an angle of 50 degrees to the shank).
  
2. The anchor is lowered over the port side to deck level. Care is to be exercised that the chain does not run over the side of the crane barge. The load is taken up by the deck winch wire. The attachment to the deck winch wire is made with the toggle mechanism in place. A crown marker buoy is secured to the crown of the anchor. This buoy and its wire rope riser will serve two purposes: to indicate drag of the anchor during test pull and, should for any reason the anchor chain subassembly be lost, it can be recovered by lifting on the crown marker buoy. This will



12 SHOTS  
OF 2"  
DIA. CHAIN

1/2 SHOT  
OF CHAIN  
AND SWIVEL

CRAW  
ON

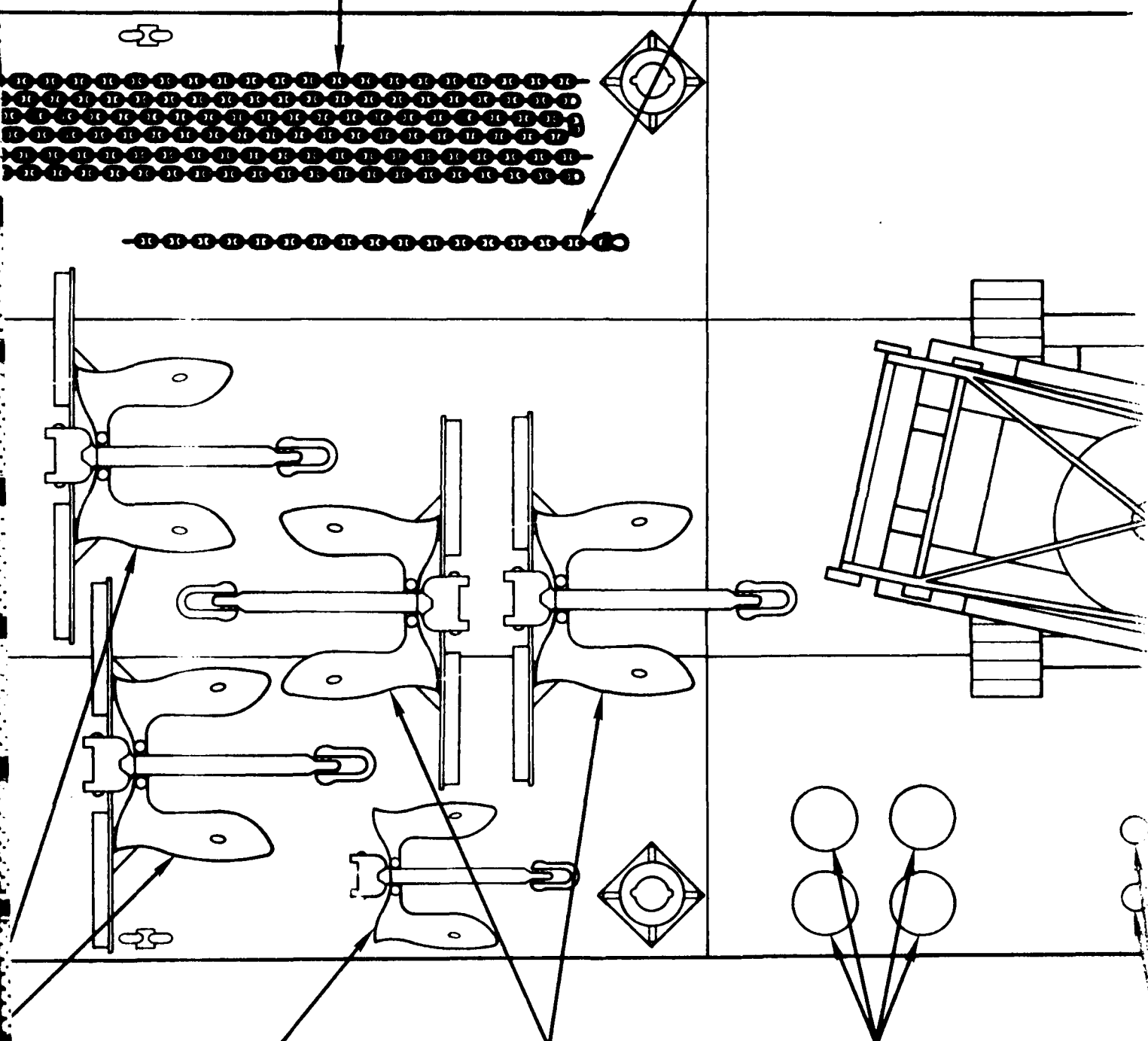

10,000 lb.  
ANCHORS

13,000 lb.  
ANCHOR

25,000 lb.  
ANCHORS

3' ANCHOR  
CROWN BUOYS

1  
RETR  
BUOY

**AWLER CRANE  
ON TRACKS**

**BUOY**

**DECK  
STOPPER**

**DECK  
PADEYE**

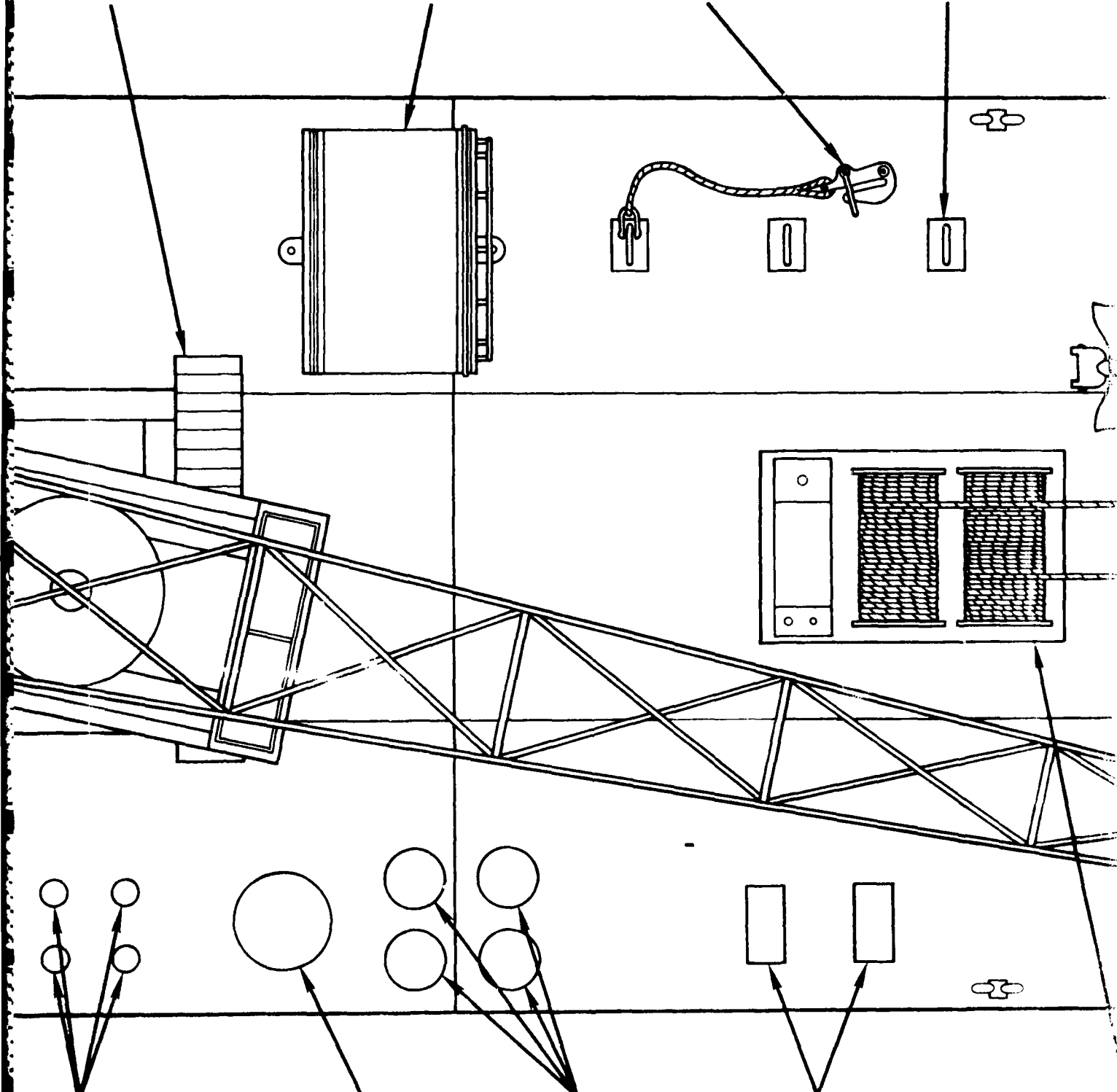

**16"  
RETRIEVER  
BUOYS**

**5' CENTER  
MARKER  
BUOY**

**3' RING  
MARKER  
BUOYS**

**STORAGE  
BOXES**

**DOUBL  
DECK**

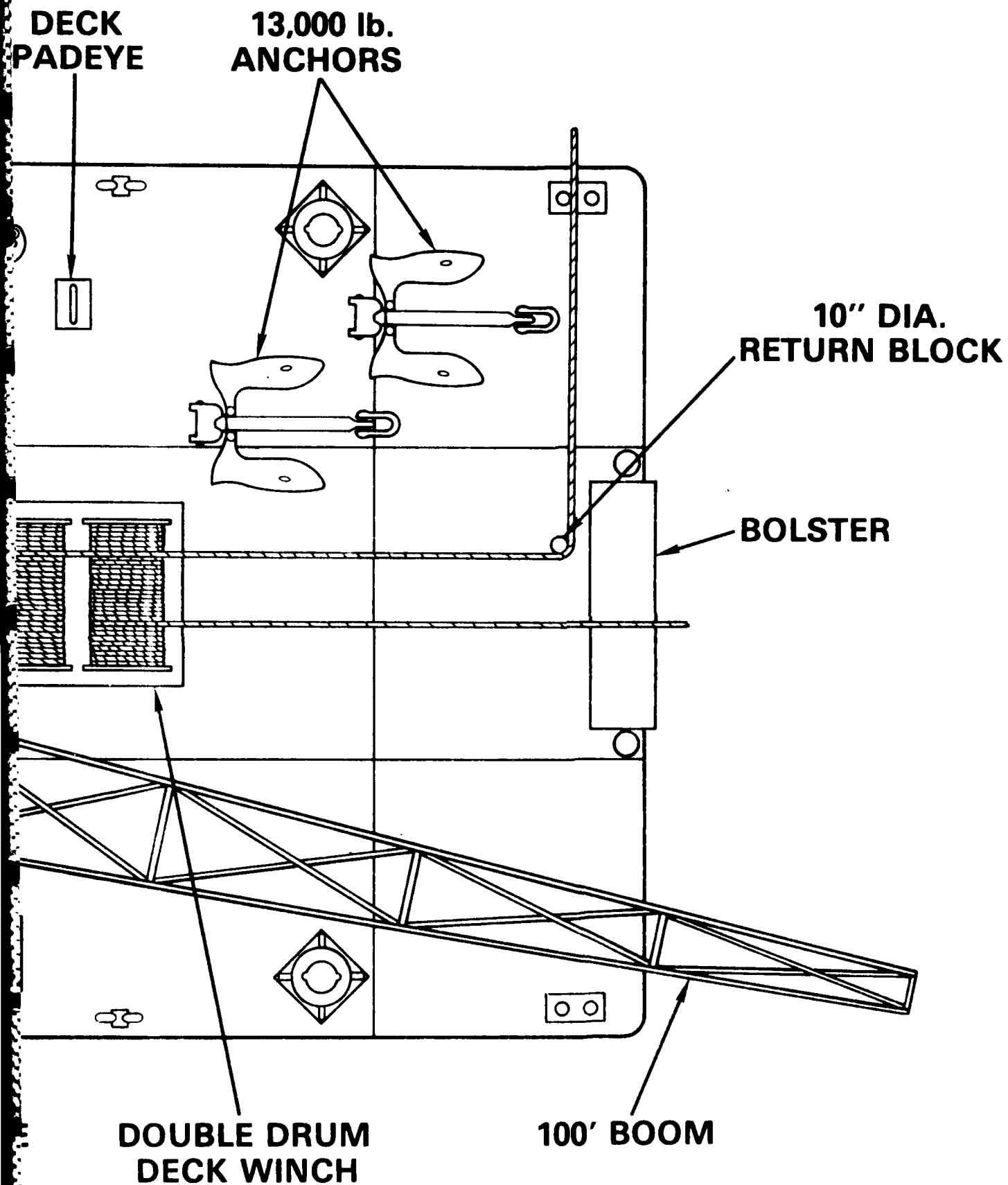

FIGURE 2-3. Mooring Components Layed Out On The Crane Barge

require the fitting of a wire rope (lazy) pendant from the top of the crown buoy to the riser to facilitate lifting (see Figure 2-4).

3. The crane is attached ten links back from the end of the first shot of chain. The crane lifts the shot of chain.
4. The anchor, attached to the deck winch wire by its bridle, is lowered over the port-side forward. The chain is lowered simultaneously by the crane, located amidships along the port side. (Note: The horizontal distance between the chain and bridle lowering locations alleviates any tendency of the anchor and/or chain to twist while being lowered through the water column.)
5. When the anchor reaches the bottom, the toggle release mechanism is slipped and the winch wire and bridle are recovered. It must be ensured that the crown marker buoy is not fouled, and has an attached wire rope (lazy) pendant accessible for recovery.
6. The crane barge is moved in a straight line towards the center marker buoy lowering chain at the same time.
7. The end of the chain is stoppered off with a deck chain stopper (see Figure 2-5), and the second shot of chain is attached. Repeat step number six.

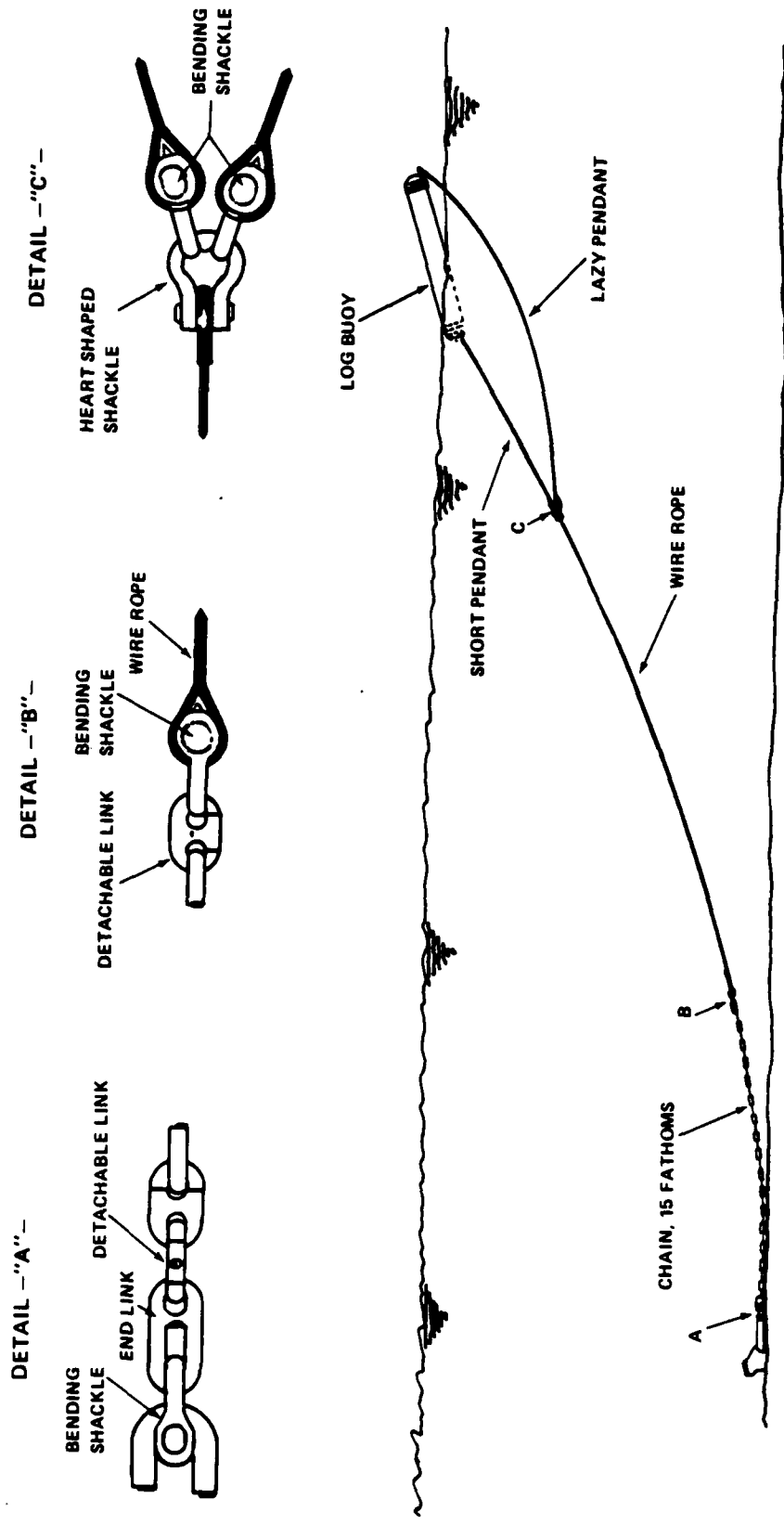

Figure 2-4. DETAILS OF A LAZY PENDANT, AND A RETRIEVER BUOY.

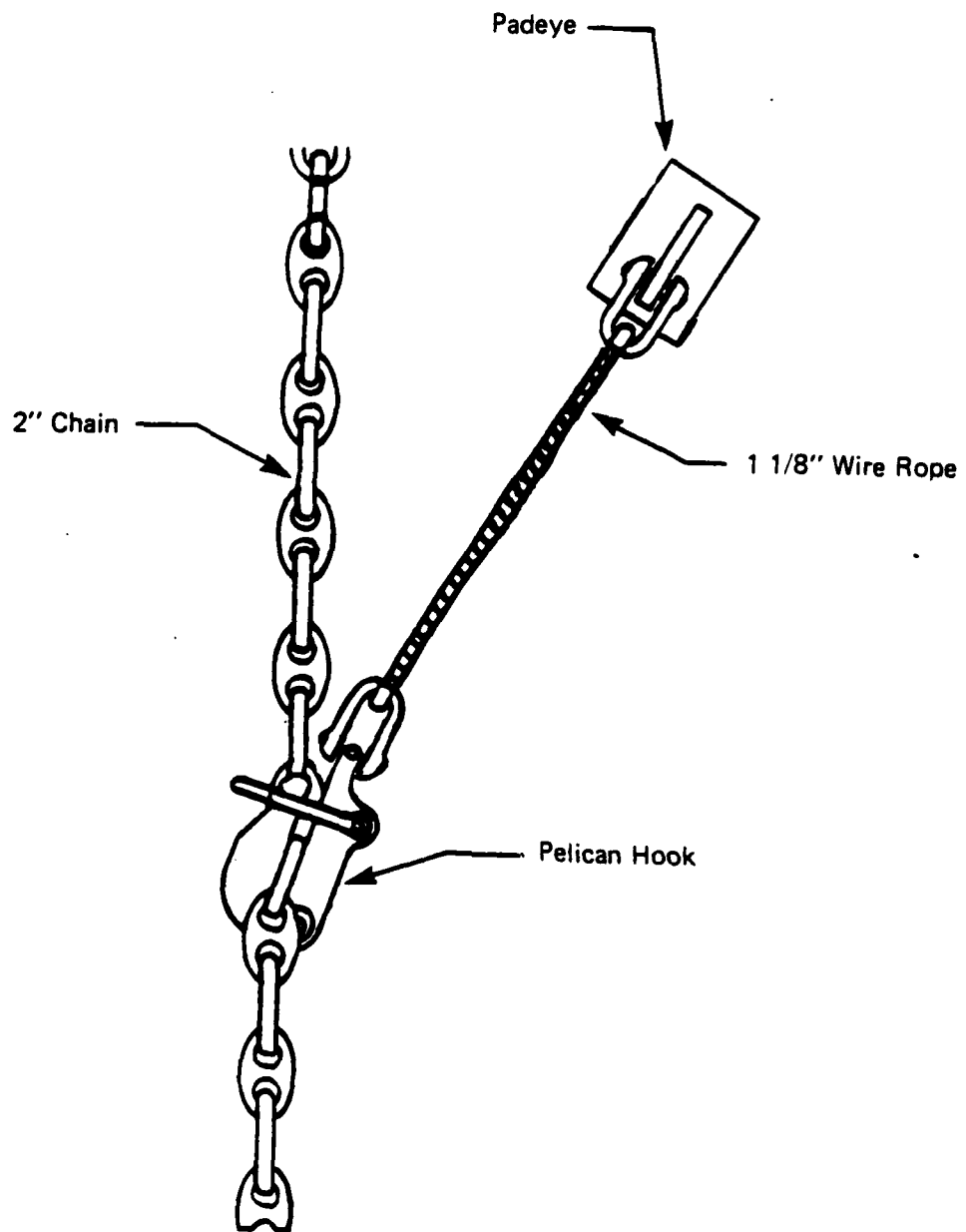

FIGURE 2-5. Deck Chain Stopper

8. A 13K pound anchor, used as a sinker, is temporarily secured to the chain with a sinker shackle one and a half shots forward of the anchor connection. The purpose of the anchor sinker is to provide resilience to the chain subassembly during pull testing. This procedure is only required on mooring legs 1 and 3.

(Note: This is required for the design load test pull only and will be recovered after satisfactory completion of the test pull.)

9. The anchor sinker is lowered as the barge moves off toward the center marker buoy. The third shot of chain is lowered simultaneously with the crane barge's movement.
10. The third shot of chain is secured with a wire pendant and a retriever buoy which are lowered into the water. The last link is secured by a shackle, to the winch wire, then lowered into the water. This completes installation of the first leg.
11. The next leg to be installed is leg number 3. Procedures 1 through 10 are repeated, the only variation being that the return wire secured to the number 1 leg is hauled in on to return to the center marker buoy. This will be used to keep number 3 leg straight and taut by keeping a constant strain on the hauling winch wire and pulling one leg against the other. (Note. The chain on numbers 3 and 4 legs is to be marked 90 feet from the end. This will indicate the position of the dynamometer connection on these legs taking into consideration the end of the crane barge will be 75 feet from the center marker buoy location).

2.4 Pull Test Procedures. At this point, with two of the four legs installed, a pull test is to be conducted. This will serve as a qualitative test of the anchors while setting them to the desired depth. The test will only be conducted on the first two mooring legs installed. The test will be repeated at each mooring site.

2.4.1 Rigging the Crane Barge for a Pull Test. Depending on the rated pull of the winch, a purchase may or may not be required. A currently calibrated dynamometer is required and, since the one available is rated under 55,000 pounds, the chain will require double rigging, to halve the load on the dynamometer. (see Figure 2-6).

2.4.2 Pull Test Requirements. The design specification calls for a load test consisting of a minimum of a 55,000 pound horizontal pull applied at diagonally opposed mooring legs (two only) for a period of 15 minutes.

A physical measurement can be made before and after the pull test between the ring marker buoy and the anchor crown buoy, to determine drag distance. However, the Engineer-in-Charge may wish to fix the crown buoy by theodolite triangulation from ashore both before and after the pull test.

All findings during the test pull will be documented and included in the "as-built" drawings.

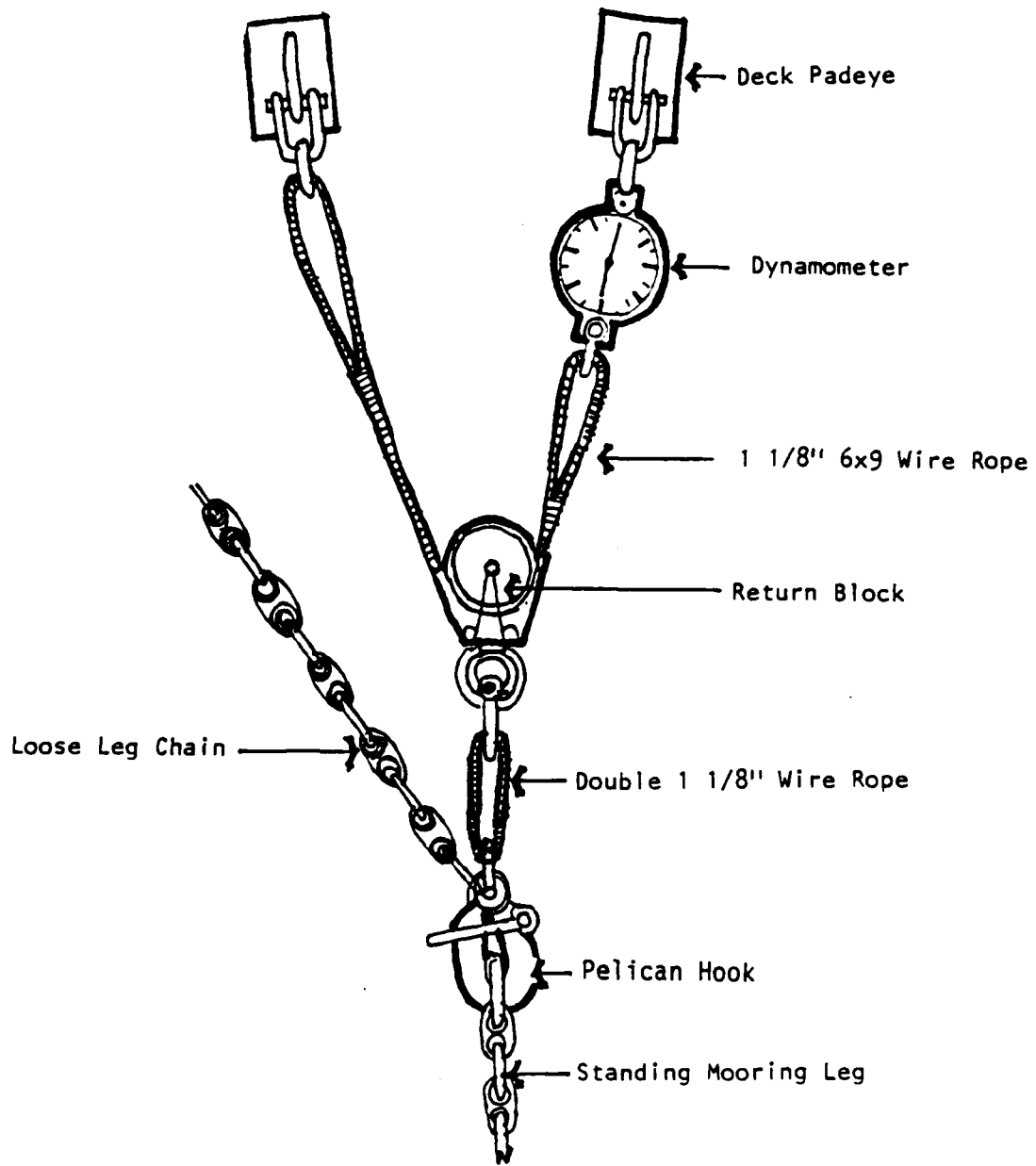

FIGURE 2-6. In-Line Dynamometer

### 2.4.3 Test Procedures:

1. The crane barge is maneuvered to a position where the center marker buoy is close aboard the port side of the barge.
2. The opposing chain legs to be test pulled are brought up on deck of the crane barge, number 1 leg over the bow and leg number 3 over the stern end.
3. A winch pulling wire is secured 45-feet from the end of the forward (No. 1) chain leg.
4. The opposing stern chain leg (No. 3) will be secured on deck with the dynamometer in-line (see Figure 2-7).
5. Before applying the full test load of 55,000 pounds, a tension of 25,000 pounds is applied for 15 minutes. This will take up slack chain, adjust pulling position, and determine the crane barge's location in relation to the center marker buoy.
6. A maximum anchor drag of 20 feet is acceptable. If an anchor drags more than 20 feet, it is to be reset and tested until a drag of 20 feet or less is attained. If the anchor should move during the first pull test, the Engineer in-Charge may decide to allow 24 hours for the anchor to settle before conducting any further pull tests.

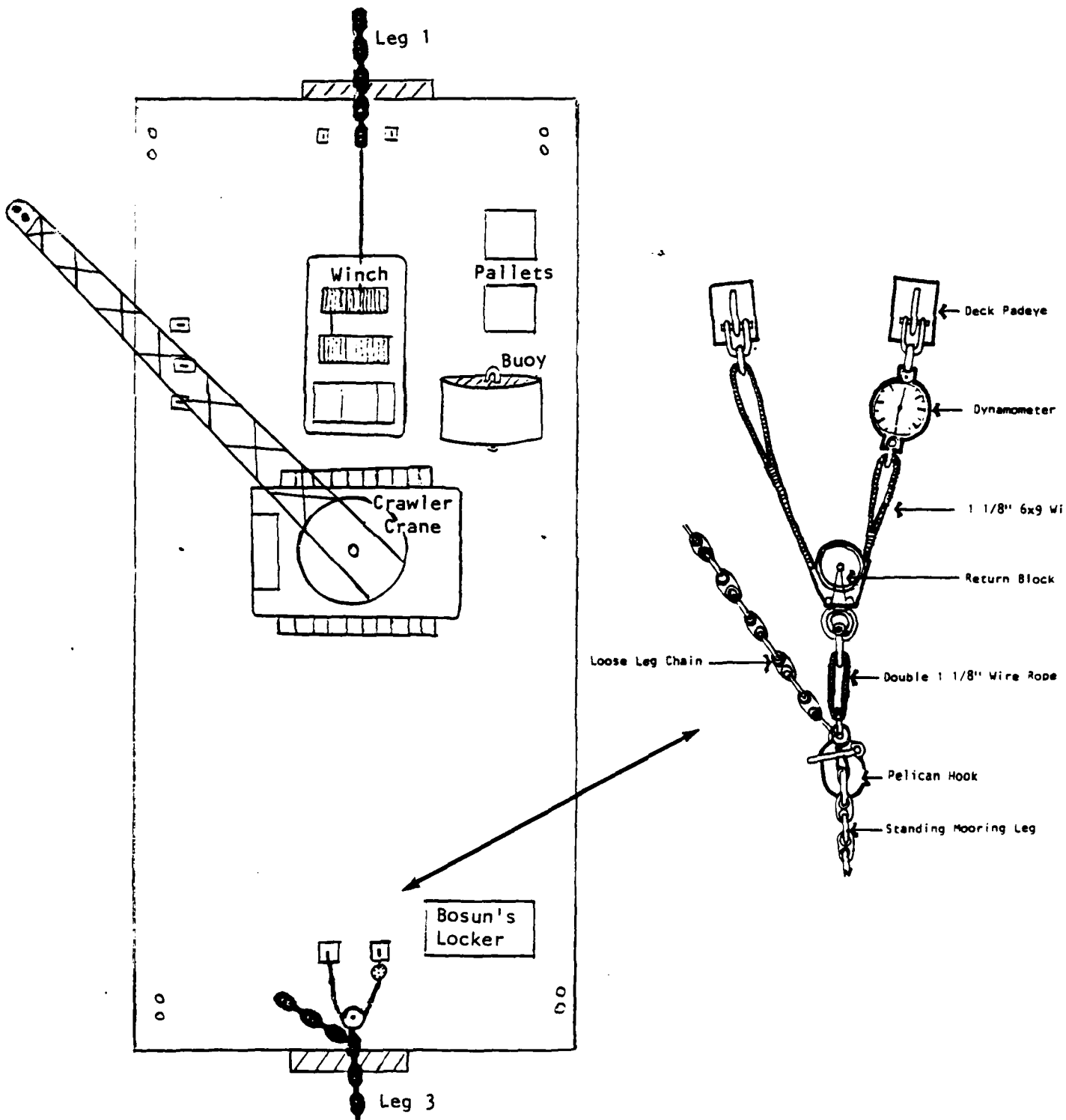

FIGURE 2-7. Pull Test Barge Configuration

## 2.5 Continued Installation Procedures

1. Having completed the pull test to the satisfaction of the Engineer-in-Charge, disconnect the pull test rigging. The two 13K anchor sinkers will then be recovered.
2. The chain leg (No. 1) leading out from the bow of the barge is lowered on the winch wire.
3. The chain leg (No. 3) leading out from the stern of the barge is lifted by the crane and the temporary anchor sinker is removed.
4. By hauling in on the winch and paying out on the chain after leading around the stern to the working area port side amidships, leg number 3 is reinstalled.
5. The chain is stoppered off four links back from the end of number 3 leg at the 255 foot mark.
6. The leg's bearing is checked in relation to the center marker buoy.
7. The chain is lengthened or shortened to line up with center marker buoy.
8. The leg is then connected to the ground ring, and stoppered off on deck.

9. The buoy (with the riser connected) is connected to the ground ring.
10. Lift the buoy and riser to release the stopper. (Riser length to be water depth (MLW) + 4-feet and will be cut to length on site).
11. The buoy, riser, and ground ring (with the chain leg attached) are lowered into the water. A return warping line is secured to the top of the buoy and paid out.
12. The forward chain leg is recovered by hauling in on the winch wire.
13. The chain is transferred to the crane and the winch wire released. The chain is brought around to the port side.
14. The chain is stoppered off when it lines up with the center marker buoy and the mooring buoy is close aboard. (Note: At this time do not cut or lengthen the chain leg.)
15. The line attached to the mooring buoy is hauled in and the mooring buoy lifted until the ground ring and leg are accessible and the leg is stoppered off. Slew the crane with the buoy and slack riser clear of working area.
16. Connect the number 1 leg to the ground ring. Cut or lengthen the leg as field conditions dictate.

17. Lift the buoy and riser, release the leg stoppers, and lower the buoy into the water.
18. The procedures 1 through 11, with the exception of the test anchor attachment and the pull test, are now conducted for legs 2 and 4.
19. Connect legs 2 and 4 to the ground ring.
20. Lower the buoy into water.
21. The 13K anchor sinker is lifted with the crane, stoppered off over the side and connected to the ground ring.
22. The crane then slings the buoy and lifts it, the riser, ground ring, and sinker until the stoppers can be released.
23. The buoy is now lowered into the water.
24. This completes the installation. The same procedures will be followed for all three moorings unless field conditions dictate otherwise.

## 2.6 Watch Circle Pull Test

The procedures for a watch circle pull test are as follows:

1. At the start of the test, new angles should be taken from at least two established reference points ashore such as beacons, lighthouses, smokestacks, towers, or range markers to the mooring buoy.
2. A tugboat is secured to the mooring buoy, with a towline incorporating a dynamometer, and a reduced load applied as the tugboat circles around the buoy (see Figure 2-8). A reduced load is normally about half the moorings designed horizontal load. For every 60 degrees of heading change of the tugboat, angle readings are taken from the ashore reference points. At the completion of the circular pull test, this series of angles can be used to develop a plot of the watch circle showing the buoy's displacement under the particular reduced load applied.
3. The results of this test shall be fully documented and included in the "Project As-Built Documentation Report".

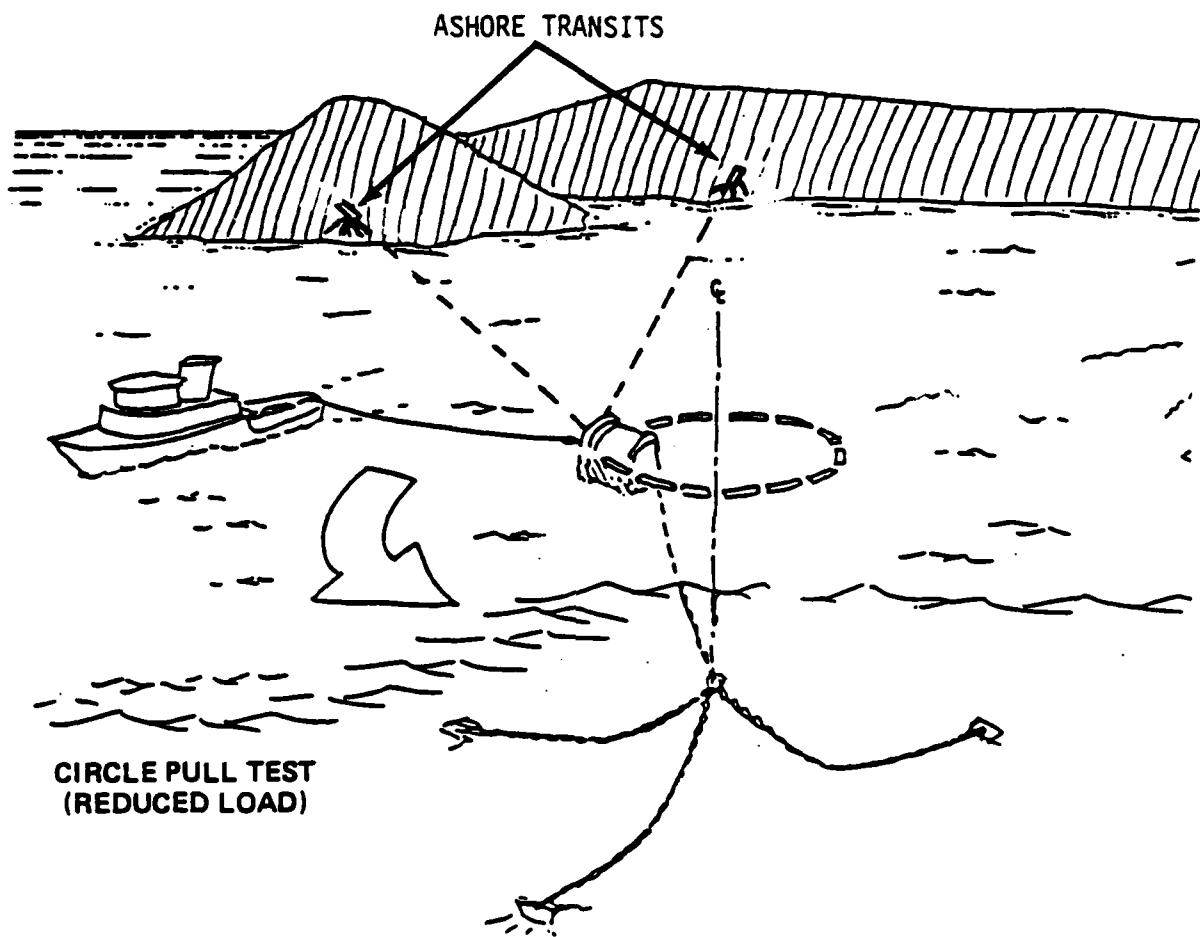

FIGURE 2-8. WATCH CIRCLE PULL TEST TECHNIQUE

ANNEX A  
MATERIAL REQUIREMENTS

## MATERIAL REQUIREMENTS

### Mooring Component Requirements

NCBC Davisville will provide:

12 each 25K pound Navy standard stockless anchors with stablizers

PWC San Diego will provide:

7 each 2-inch Kenter detachable chain joining links

13 each 2 1/4-inch detachable chain joining links

NCBC Gulfport will provide:

37 1/2 shots 2-inch chain

3 each 2-inch ground rings

15 each 2-inch swivels

38 each 2-inch Kenter detachable chain joining links

27 each 2-inch anchor joining links

13 each 2 1/2-inch anchor joining links

5 each 2 1/2-inch "F" shackles

6 each 2 3/4 inch "F" shackles

9 each 2-inch sinker shackles

NAVSTA Mayport will provide:

5 each 13K pound anchors (to be used to provide resilience to the chain subassembly during pull testing and to act as sinkers.)

Support Material/Equipment Requirements

CHESNAVFACENGCOM will provide the following:

FPO-1

Copy of DM-26

Calipers

GO/No-Go Gauges

Hand Held Range Finder

OCEI

200 each hose clamps for 2-inch chain

1 each Underwater Voltmeter with a surface readout capability

1 each in-line W.C. Dillon Dynamometer with a 40,000 pound capacity.

This dynamometer must be currently calibrated.

Assorted shackles

1 1/4" wire rope

EDM equipment

12 each float ballons

16 each 100-foot lengths of 5/16" continuity wire (6 x 9 steel)  
4 each 60-foot lengths of 5/16" continuity wire (6 x 9 steel)  
2 each Padeyes 15-tons  
1 each Padeye 50-tons  
2 each Sheave blocks 24-inch  
1 each Snatch block 16-inch  
1 each Can buoy 2'-6" x 4' -0  
10 each Buoys 26" spherical  
2 each Bins of 1 1/2" dia. Nylon Braided Line  
4 each Pelican Hooks chain type for 2" chain  
2 each Reels 1 1/4-inch wire  
1 each Burger fairlead  
9 each Hook type snatch blocks  
1 each 1 1/4" carpenters stopper (no bridle)  
1 each 3/4" carpenters stopper (no bridle)  
12 each 1 1/4" x 10-foot wire strops soft eye each end  
5 each 5/8" x 4-foot wire strops soft eye each end  
6 each 5/8" x 16-foot wire strops soft eye each end  
2 each 1" x 12-foot open link chain  
2 each 50-tons bow safety shackles  
2 each 35-tons bow safety shackles  
16 each 2" safety shackles  
4 each 2 1/2" bow shackles  
1 each screw pin type long shank sinker shackle  
6 each 1 1/2" screw pin type working shackles  
1 each pear link 2 inch (for anchor slipping gear)  
1 each "D" type shackle 2 inch

TRACOR Marine (Contractor) will provide:

- 1 each 100-ton crane with operator and fuel
- 1 each 150- x 45-foot barge with two spuds
- 1 each pusher boat with operator and fuel
- 1 each AMCON winch number 385
- Miscellaneous equipment as required.

UCT ONE will provide:

EA Kit

- 2 each 100-foot tapes
- 2 each theodolites
- 6 each range rods
- 2 each 300-foot chain reels
- 4 each walkie talkies

Bosun's Locker

- 16 each 1-inch shackles
- 6 each 1 1/2-inch shackles

Miscellaneous

- 3 each 5/8-inch pin hammers

1 coil 1/4-inch, 3-strand nylon rope  
12 each 1 1/4-inch wire clips  
4 each wire brushes  
welding rods  
1 coil seizing or bailing wire  
1 coil 1/4-inch, 3-strand polypropelane rope  
2 each crowbars  
2 each 10-pound sledge hammers  
2 each 3 1/2-pound, double-faced engineer's hammers  
2 each 5-foot by 7/8-inch hexagon wrecking bars  
2 each 36- by 2-inch hexagon bar stock for toggle bars  
16 each 2- by 4-inch by 8-foot wood studs  
12 each work vests  
12 each cans of white spray paint  
50 each 3/4-inch wire clips  
2 each spud wrench  
2 each 2-inch pelican hook (chain type)  
6 each polyurethane floats  
5 gallon drum of grease  
1 small boat  
1 each impact wrench and compressor  
1 each grinder  
Consumables as required  
3 each chain hooks  
1 each 14-foot Zodiac  
Hard hats and steel-toe boots

ANNEX B  
USE OF THE  
UNDERWATER VOLTMETER

## USE OF THE

### UNDERWATER VOLTMETER

Steel that is protected from corrosion by placing an even more electro-negative zinc anode on its surface should have potentials that fall between  $-0.80$  V and  $-0.90$  V. A greater potential ( $-1.50$  V) indicates that the anode is overworking and serious damages could occur to the metal. A lesser potential ( $-0.50$  V) indicates that the cathodic protection system is not operating effectively and that the steel as well as the anode material will probably corrode.

A typical reference electrode is silver/silver chloride (Ag-AgCl). The difference between this electrode and the metal being tested is the potential displayed by the voltmeter. Because steel is more electronegative than the reference electrode, the voltage will be negative.

The following description and operating instructions refer to a typical underwater voltmeter presently maintained by the Ocean Construction Equipment Inventory (OCEI) Facility. (See Figure B-1). This voltmeter consists of a digital display, surface readout facility, and rechargeable battery. A robust Ag-AgCl reference electrode is mounted in the nose cone 5 cm from the probe tip. The probe and the half cell are connected internally to a digital voltmeter. Operation involves monitoring the readout. The potential is shown on the liquid crystal display (LCD) which is back-illuminated for operation in low visibility. Due to the mud bottom conditions in the St. Johns River, however, it will be almost impossible for divers to read this display. For this reason, a cable will be attached to the voltmeter and the readings taken on the surface from a meter attached to the cable (see Figure B-2).

The voltmeter is supplied with six probes. This should be suitable for all mooring inspections. The probes are attached to the front of the instrument by screwing them onto the stainless steel stud. Silicon grease should be applied to the probe threads before attachment. A definite bottoming should be felt when the probe has been fully screwed in.

The unit is switched on by using the 4-pin blanking plug provided, which, in order to conserve battery life, should be disconnected when the instrument is not in use. Silicon grease will ease insertion. THE PLUG IS NOT UNDERWATER PLUGGABLE AND MUST BE INSERTED BEFORE THE INSTRUMENT IS IMMersed, OR ELECTRONICS DAMAGE WILL RESULT.

Under normal usage, a fully charged battery will operate for 60 hours. A "1" displayed on the LCD indicates low voltage. Should this occur, a maximum charge of 14 hours at the high charge setting will bring the battery back to the fully charged condition. This should be done with the supplied battery charger. As a general guide, 10 minutes of recharging (at 9 milliamperes (mA)) is required for every hour of use.

The low-charge setting provides a continuous trickle charge output of 1 mA and can be used to ensure that the batteries maintain a full charge when the unit is kept on the shelf.

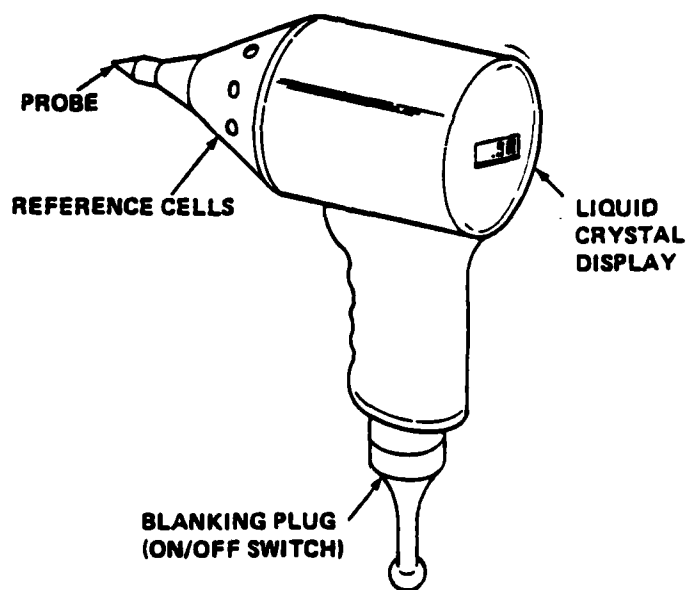

FIGURE B-1. UNDERWATER VOLTMETER

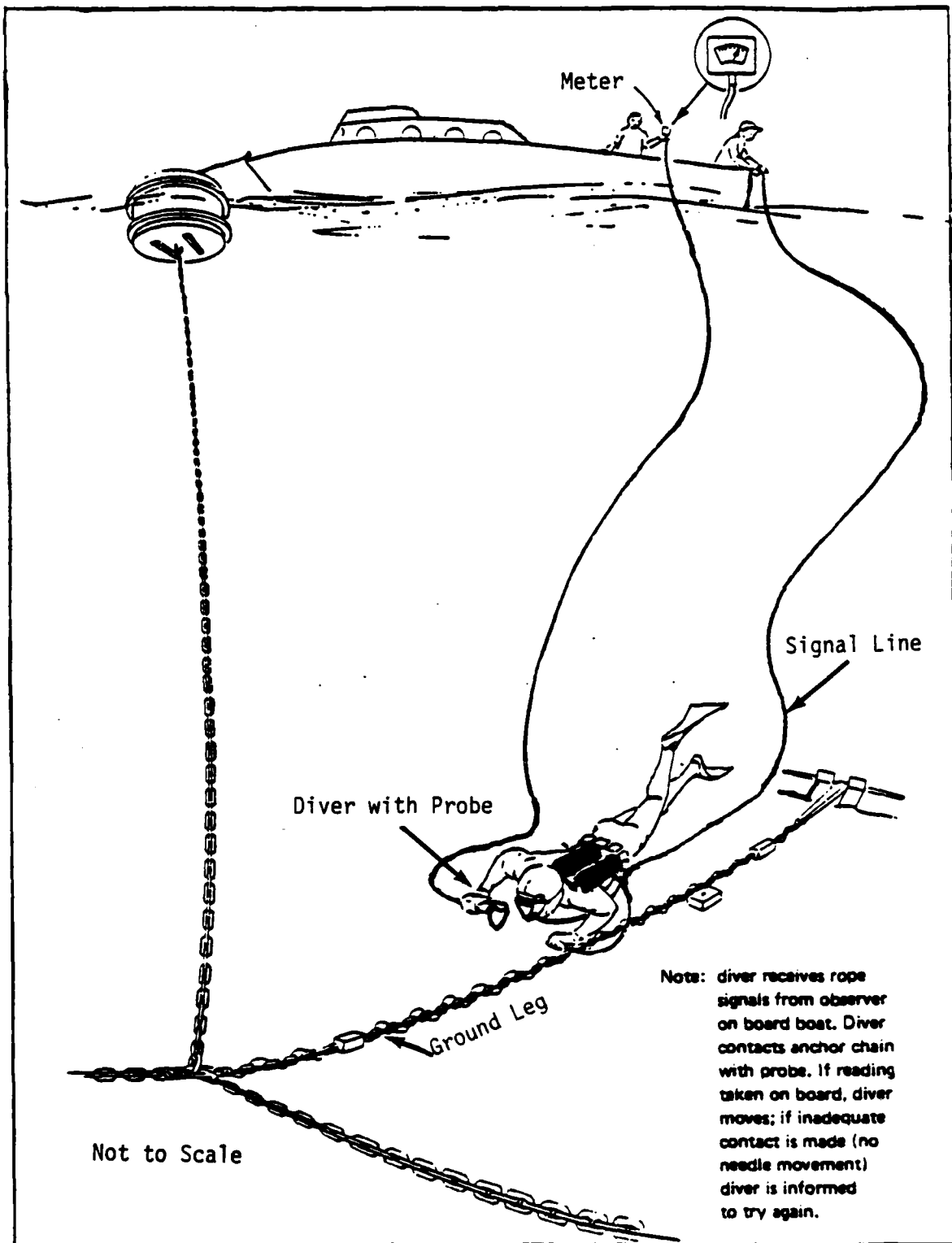

FIGURE B-2. Diver Inspection of a Cathodic Protection System

Because some drying out may occur during storage, it is recommended that prior to initial use the half cell be allowed to soak for 20 to 30 minutes. A thin stream of bubbles may be seen emitting from the half cell area, indicating the ingress of water into voids, expelling any trapped air.

The unit operates on the principle of measuring the potential difference between the structure (steel) and a reference electrode (silver). The probe, a different metal than the reference electrode, will exhibit a small potential difference which will be shown as a reading on the digital display. However, the exposed area of the probe tips has been kept to a minimum and any surface being tested will be many hundreds of times greater in area. Therefore, when contact of the probe with the surface is made, only the structure potential will be indicated. Any slight interference from the probe will be masked by the structure's potential. Some slight readings may still be apparent on the display when the unit is removed from the water. This is due to surface moisture allowing tracking from the half cell to the probe which, although slight, will be displayed because of the high input impedance of the meter.

#### Calibration and Maintenance.

In order to keep a check on the operation and calibration of the silver reference electrode, tests should be carried out at the surface prior to each operational use as follows:

- (1) Samples of zinc are used, their potential measurements with the underwater voltmeter taken, and a log of these readings kept to check if any significant variance occurs. THE METER MUST BE UNDERWATER WHEN CALIBRATED.
- (2) Differences of 10 millivolts (mV) (.01 V) or so between calibration readings are quite possible and will be caused mainly by variations in water salinity or temperature.
- (3) Very little mechanical maintenance is required, apart from general cleaning in fresh water after each use and ensuring that the nose cone, behind which the reference electrode is situated, is kept clear of any obstruction such as dirt or marine growth.

## PROCEDURES.

a. To assure proper protection of the chain or wire rope, underwater voltmeter readings must be taken at 20-foot intervals on the leg, on each side of each anode, at each end of the continuity cable, and on each side of each swivel. Wherever readings are taken, potentials, depth and element measured (whether chain, anode, etc.) shall be recorded.

b. The anode and cable must be checked for secure attachment to the chain and the amount of loss due to corrosion shall be noted.

c. Chain that is cathodically protected must have potential readings between  $-0.80$  V to  $-0.90$  V. (NOTE: The negative sign will not appear on the voltmeter readout.) Typically, the largest potentials ( $-0.85$  V to  $-0.90$  V) will be at the anode and the smallest ( $-0.80$  V to  $-0.85$  V) will be at each end of the continuity cable. Any readings higher ( $-0.50$  V, etc.) or lower ( $-1.50$  V, etc.) than this range will be investigated as follows:

- (1) Return to the last checkpoint within the correct range.
- (2) Probe and read the voltmeter every 5 feet until the corrosion cell or faulty area is located.
- (3) Report this unprotected or overprotected area by relating it to the appropriate leg (i.e., leg A). Identify the cell by its physical position (e.g., near a swivel or an anode) and record the depth. Record at least two positions, preferably one higher and one lower than the corrosion cell on the chain.

ANNEX C  
KENTER JOINING LINK  
ASSEMBLY PROCEDURES

## KENTER JOINING LINK

Kenter Joining Link. The Kenter type joining link is of alloy steel and constructed in three parts, one of which is the stud. The two main parts and stud have matching numbers and an arrow on the stud which is lined up with an arrow on the main part for ease of assembly. The two main parts are attached to the ends of the chain in the vertical position and then fitted together, the stud slides in place and locks the whole link. The stud is secured by hammering a tapered pin into the hole drilled diagonally through all three parts of the joining link. This hole is tapered, and when the pin is driven home a small conical recess, called the "Dovetail Chamber" is left clear above its head. A lead pellet is hammered broad end first into this chamber so as to fill it completely and thereby keep the pin in place. During the final stage of hammering the lead pellet into the Dovetail Chamber, precaution must be taken to prevent flat, small pieces of lead flying off the joining link into the face or eyes. The assembly procedure is depicted on the last two pages of this Annex.

Prior to assembly the internal mating surfaces of a Kenter joining link should be slushed with a mixture of 40 percent white lead and 60 percent tallow by volume. When assembling and before inserting a lead pellet any remaining lead in the Dovetail Chamber must be reamed out with a reamer tool. Failure to do this could result in the new lead pellet working out. After assembly of the link wipe off the excess white lead and tallow. The link is then painted with anchor chain paint, MIL-P-24380 (NSN 8010-00-145-0332 and NSN 8010-00-145-0341 for 1 and 5 gallon cans respectively).

When disassembling a Kenter joining link, the locking pin is driven out with a "drift." To part the link, a top swage must always be used between the hammer and link. The swage is shaped to the curvature of the link so that machined surfaces are not damaged (see Figure C-1).

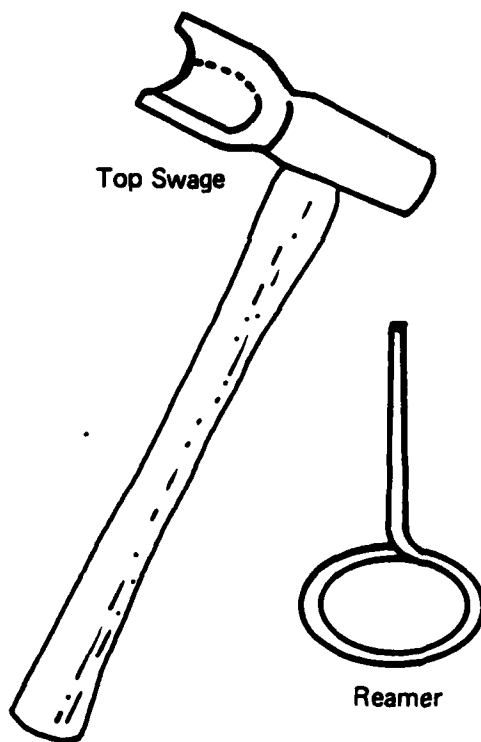
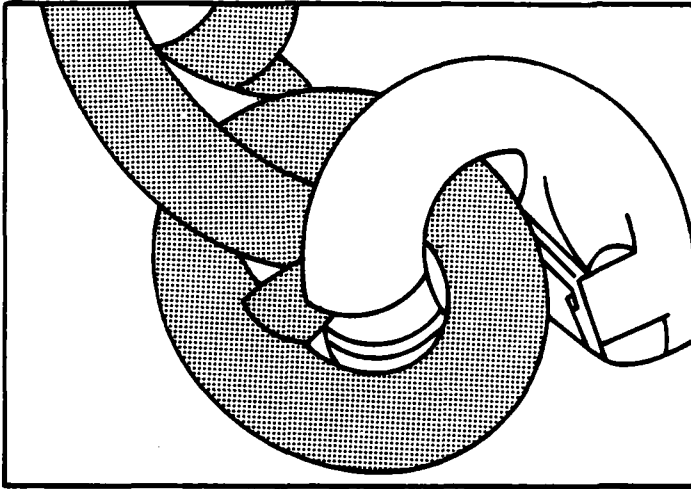

FIGURE C-1. A Top Swage

## KENTER JOINING LINK ASSEMBLY PROCEDURE



1

The half shackle is reeved in the link.  
(Only one of the chain links is shown).

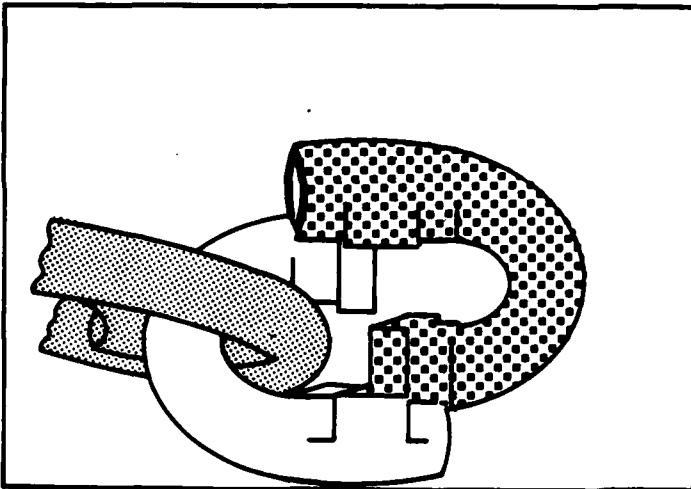

2

The link halves are inserted one in the other and driven together.

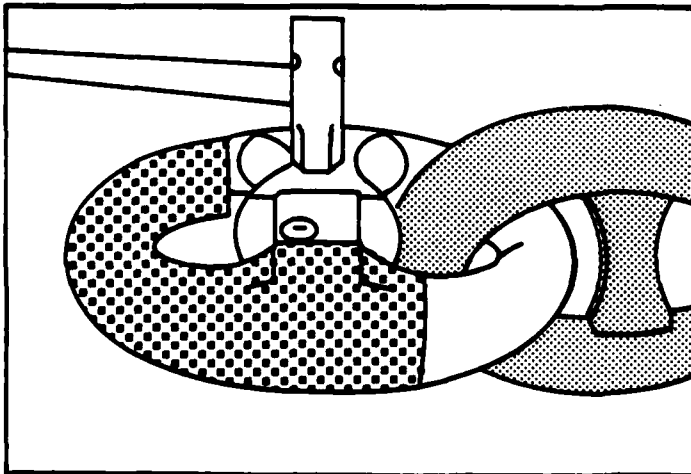

3

The center chock is inserted.

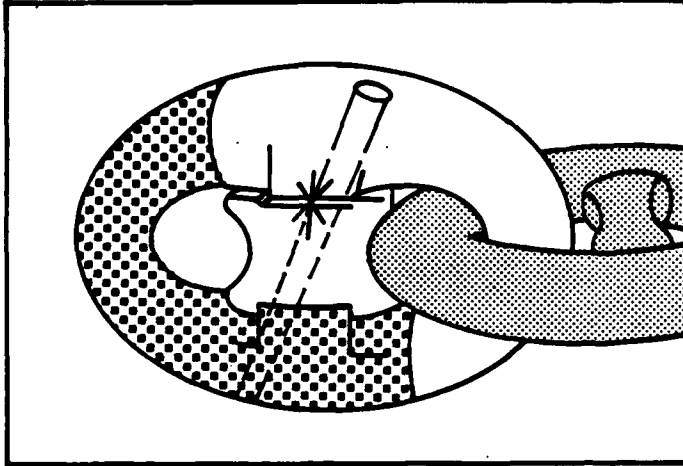

4

Just for a trial the taper pin is inserted in the center chock. When the center chock is in correct position the taper pin can without a hammer be inserted as shown on the figure which also shows the center chock in correct position.

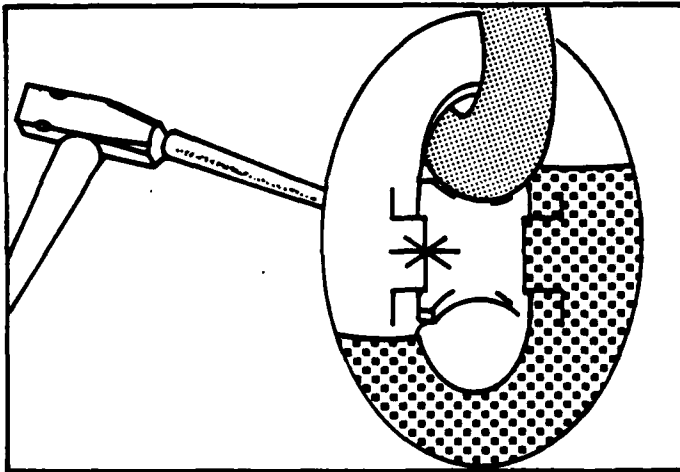

5

The taper pin is driven in and is secured by the lead pellet which is inserted into place with a hammer.

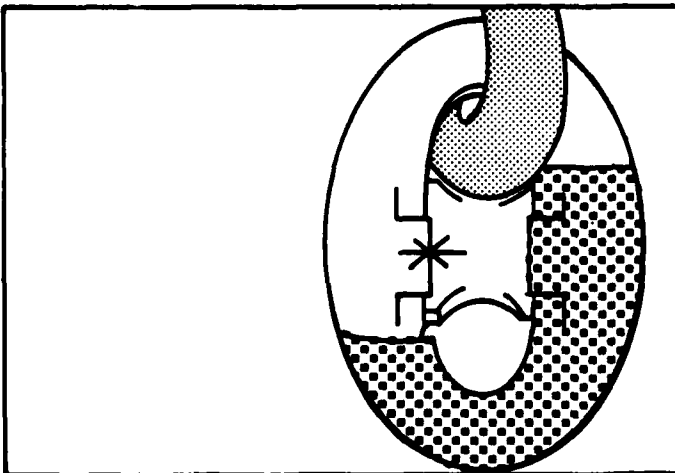

6

Assembled Kenter shackle.

ENTR  
DITIC

7-86