

AD-A168 602

UNDERWATER FACILITIES INSPECTIONS AND ASSESSMENTS AT
NAVAL AIR STATION NE. (U) OCELINE ENGINEERING INC
CORPUS CHRISTI TX JUN 85 CHS/NAUFAC-PPO-1-85(18)
N62477-85-D-0003

1/1

UNCLASSIFIED

P/C 13/2

ML



2746

END
JUN 85

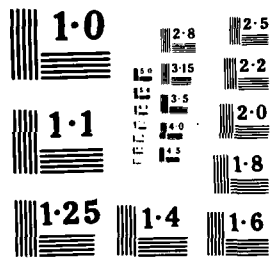

FPO
8518

INFORMATION FACILITIES INSPECTIONS & ASSESSMENTS

(1)



AD-A168 602



DTIC FILE COPY

DTIC
ELECTE
JUN 13 1986
S D

*Original contains color
plates: All DTIC reproduct-
ions will be in black and
white*

DISTRIBUTION STATEMENT A

Approved for public release;
Distribution Unlimited

86 6 12 149

UNDERWATER FACILITIES
INSPECTIONS
AND
ASSESSMENTS
AT



DTIC
ELECTE
JUN 13 1986
S D
D

NAVAL AIR
STATION
NEW ORLEANS, LA.

FPO-1-85-(18)

JUNE 1985

PERFORMED FOR:

OCEAN ENGINEERING AND CONSTRUCTION PROJECT OFFICE
CHESAPEAKE DIVISION
NAVAL FACILITIES ENGINEERING COMMAND
WASHINGTON, D.C. 20374

UNDER:

CONTRACT N62477 - 85 - D - 0083
TASK I

BY:

OGLETREE ENGINEERING, INC.
CORPUS CHRISTI, TEXAS 78413

DISTRIBUTION STATEMENT A
Approved for public release
Distribution Unlimited

Unclassified
SECURITY CLASSIFICATION OF THIS PAGE

AD-A168602

REPORT DOCUMENTATION PAGE

1a. REPORT SECURITY CLASSIFICATION
Unclassified

1b. RESTRICTIVE MARKINGS

2a. SECURITY CLASSIFICATION AUTHORITY

3. DISTRIBUTION AVAILABILITY OF REP.
Approved for public release;
distribution is unlimited

2b. DECLASSIFICATION/DOWNGRADING SCHEDULE

4. PERFORMING ORGANIZATION REPORT NUMBER

5. MONITORING ORGANIZATION REPORT #
FPO-1-85(18)

6a. NAME OF PERFORM. ORG. 6b. OFFICE SYM
Ogletree Engineering, Inc.

7a. NAME OF MONITORING ORGANIZATION
Ocean Engineering
& Construction
Project Office
CHESNAVFACENCOM

6c. ADDRESS (City, State, and Zip Code)
Corpus Christi, TX 78413

7b. ADDRESS (City, State, and Zip)
BLDG. 212, Washington Navy Yard
Washington, D.C. 20374-2121

8a. NAME OF FUNDING ORG. 8b. OFFICE SYM

9. PROCUREMENT INSTRUMENT INDENT #
N62477-85-D-0083, Task 1

8c. ADDRESS (City, State & Zip)

10. SOURCE OF FUNDING NUMBERS
PROGRAM PROJECT TASK WORK UNIT
ELEMENT # # # ACCESS #

11. TITLE (Including Security Classification)

Underwater Facilities Inspections and Assessments at Naval Air Station New Orleans, LA

12. PERSONAL AUTHOR(S)

13a. TYPE OF REPORT

13b. TIME COVERED
FROM TO

14. DATE OF REP. (YYMMDD)
85-06

15. PAGES
30

16. SUPPLEMENTARY NOTATION

17. COSATI CODES
FIELD GROUP SUB-GROUP

18. SUBJECT TERMS (Continue on reverse if nec.)
Underwater inspection, Naval Air Station
New Orleans, LA

19. ABSTRACT (Continue on reverse if necessary & identify by block number)

The objective of this inspection was to generate a baseline underwater condition survey of Fuel Wharf 128 at the Naval Air Station, New Orleans, LA. Underwater, the pier was in very good condition. No significant deterioration was detected at any piles or connecting hardware. Some submerged (Con't)

20. DISTRIBUTION/AVAILABILITY OF ABSTRACT
SAME AS RPT.

21. ABSTRACT SECURITY CLASSIFICATION

22a. NAME OF RESPONSIBLE INDIVIDUAL
Jacqueline B. Riley
DD FORM 1473, 84MAR

22b. TELEPHONE 22c. OFFICE SYMBOL
202-433-3881
SECURITY CLASSIFICATION OF THIS PAGE

BLOCK 19 (Con't)

horizontal bracing exhibited a "softened" condition but not general or severe weakness. Above the waterline, fungal decay was present in numerous locations but the overall structural integrity was not significantly impaired, considering the heavy construction and relatively light loading conditions.

Recommended maintenance includes replacement of missing fender members and replacement of approximately 30% of the timber deck. Areas revealed during deck replacement should be examined for hidden decay, and "moisture traps" should be omitted.

Other deteriorated framing members (bracing, caps, and stringers) should be spliced or replaced.

"Top rot" in timber piles should be treated to prevent further deterioration and reinforce weakened upper connections.

EXECUTIVE SUMMARY

The objective of this inspection was to generate a baseline underwater condition survey of Fuel Wharf 128 at the Naval Air Station, New Orleans, Louisiana.

Underwater, the pier was in very good condition. No significant deterioration was detected at any piles or connecting hardware. Some submerged horizontal bracing exhibited a "softened" condition but not general or severe weakness. Above the waterline, fungal decay was present in numerous locations but the overall structural integrity was not significantly impaired, considering the heavy construction and relatively light loading conditions.

Recommended maintenance includes replacement of missing fender members and replacement of approximately 30% of the timber deck. Areas revealed during deck replacement should be examined for hidden decay, and "moisture traps" should be omitted.

Other deteriorated framing members (bracing, caps, and stringers) should be spliced or replaced.

"Top rot" in timber piles should be treated to prevent further deterioration and reinforce weakened upper connections.



Accession For	
NTIS CRA&I	<input checked="" type="checkbox"/>
DTIC TAB	<input type="checkbox"/>
Unannounced	<input type="checkbox"/>
Justification	
By	
Distribution/	
Availability Codes	
Dist	Avail and/or Special
A-1	

NAVAL AIR STATION
NEW ORLEANS, LOUISIANA

EXECUTIVE SUMMARY TABLE

<u>FACILITY</u>	<u>YEAR BUILT</u>	<u>TOTAL NO. OF PILES</u>	<u>LXW (FT.)</u>	<u>STRUCTURES/MATERIAL</u>	<u>RECOMMENDATIONS</u>	<u>EST. COST OF RECOMMENDATIONS (THOUSANDS)</u>
Fuel Wharf 128	1959	90	211 x 21	Cresote treated timber piles and timber super-structure	1) Replace deteriorated timber	\$ 36

TABLE OF CONTENTS

	<u>PAGE</u>
EXECUTIVE SUMMARY.	i - ii
TABLE OF CONTENTS.	iii
LIST OF FIGURES.	iv
LIST OF PHOTOGRAPHS.	v - vi
SECTION 1.0 INTRODUCTION	1 - 1
1.1 CONTRACT TASK DESCRIPTION.	1 - 1
1.2 REPORT CONTENT	1 - 1
SECTION 2.0 ACTIVITY DESCRIPTION	2 - 1
2.1 LOCATION OF ACTIVITY	2 - 1
2.2 EXISTING WATERFRONT FACILITIES	2 - 1
2.3 CLIMATE.	2 - 1
2.4 TOPOGRAPHY, HYDROLOGY, OCEANOGRAPHIC DATA.	2 - 4
SECTION 3.0 INSPECTION PROCEDURE	3 - 1
3.1 LEVEL OF EXAMINATION	3 - 1
3.2 INSPECTION PROCEDURE	3 - 3
3.3 EQUIPMENT.	3 - 4
SECTION 4.0 FACILITIES INSPECTED	4 - 1
4.1 FUEL WHARF 128	4 - 2
4.1.1 Description.	4 - 2
4.1.2 Observed Inspection Condition.	4 - 2
4.1.3 Structural Condition Assessment.	4 - 7
4.1.4 Recommendations.	4 - 7
APPENDICES	
SALINITY ANALYSIS, LABORATORY REPORT	A2
COST ESTIMATE CALCULATIONS	A3
STRUCTURAL CALCULATIONS.	A4 - A5

LIST OF FIGURES

<u>FIGURE</u>	<u>TITLE</u>	<u>PAGE</u>
1	LOCATION MAP	2 - 2
2	VICINITY MAP	2 - 3
3	FUEL WHARF 128, PLAN	4 - 3
4	FUEL WHARF 128, SECTIONS	4 - 4
5	FUEL WHARF 128, SECTIONS	4 - 5
6	CONCEPTUAL CAP REPAIR.	4 - 9

LIST OF PHOTOGRAPHS

		<u>FOLLOWS</u>
		<u>PAGE</u>
Photo 1	- Underwater photograph of uncleaned Pile 1A, Wharf 2, showing typical marine growth.....	4-5
Photo 2	- Close up underwater photograph of typical marine growth.....	4-5
Photo 3	- Underwater photograph of cleaned Pile 1A, Wharf 2, showing timber surface after removal of marine growth.....	4-5
Photo 4	- Close up underwater photograph of cleaned timber surface shown in Photograph 3.....	4-5
Photo 5	- Close up underwater photograph of plugged core holes at Wharf 3, Pile 1A. Plug is 3/4" diameter treated wood dowel.....	4-5
Photo 6	- Showing cores extracted from Wharf 3, Pile 1A.....	4-5
Photo 7	- Catwalk 2, Pile 3B, "Top Rot". Decay penetrates approximately 18".....	4-6
Photo 8	- Wharf 3, typical appearance of decayed deck member.....	4-6
Photo 9	- Decayed stringer at Wharf 3, between Bents 3 and 4, Rows B and C.....	4-6
Photo 10	- Decayed stringer at Wharf 3, between Bents 1 and 2, Rows C and D.....	4-6
Photo 11	- Decayed cap at Wharf 1, Bent 4 near Row D....	4-6
Photo 12	- Decayed cap at Wharf 1, Bent 3 between Rows C and D.....	4-6
Photo 13	- Decayed diagonal brace at Wharf 3, Pile 1E...	4-6
Photo 14	- Decayed diagonal brace at Pump Station, between Bents 1 and 2, Row A.....	4-6
Photo 15	- Decayed horizontal brace at Pump Station, between Bents 1 and 2, Row A.....	4-6
Photo 16	- Decayed horizontal brace at Wharf 3, Bent 4, between Rows B and C.....	4-6

Photo 17	-	Showing broken diagonal bracing at Wharf 1, Row A, between Bents 2 and 3.....	4-6
Photo 18	-	Showing typical extensive bracing and heavy construction of wharf.....	4-6

This engineering inspection and report was performed under the Underwater Inspection Program of the Ocean Engineering and Construction Project Office, Chesapeake Division, (FPO-1), Naval Facilities Engineering Command.

The project was performed by Ogletree Engineering, Inc., Engineering Consultants, Corpus Christi, Texas under contract N62477-85-D-0083, Task No. 1.

1.1 CONTRACT TASK DESCRIPTION

This contract task required engineering services for an underwater inspection and evaluation of structural members supporting Fuel Wharf 128 at the Naval Air Station, New Orleans, Louisiana. The contractor was to supply personnel and equipment to:

- A. perform designated levels of examination; take measurements, provide documentation and photographs, and
- B. prepare this report.

The objective was to provide a general baseline underwater condition survey from which immediate maintenance needs could be estimated and future needs could be projected.

1.2 REPORT CONTENT

This inspection report includes background information, objectives, procedures, results, evaluations, recommendations, drawings, and photographic documentation of conditions found.

The contents were derived from:

- A. Drawings and information provided by the Naval Air Station and the Chesapeake Division, Naval Facilities Engineering Command.
- B. Data collected during the field inspection at the Naval Air Station.
- C. Engineering calculations, estimates, judgements and assessments applied to the facility.

This section provides a general description of the Naval Air Station, New Orleans, Louisiana. The information was obtained from the Naval Air Station Master Plan and from conditions observed during the inspection.

2.1 LOCATION OF ACTIVITY

The Naval Air Station was commissioned in 1957 as a joint Air Reserve Training Center. It is located 16 miles southeast of the Central Business District of New Orleans, adjacent to Belle Chase in Plaquemines Parish, Louisiana. The NAS is adjacent to the Mississippi River and the Intracoastal Canal, 73 miles from the Gulf of Mexico (See Figures 1 and 2).

2.2 EXISTING WATERFRONT FACILITY

The Fuel Pier on the Intracoastal Canal provides barge mooring and off-loading facilities for aviation fuel used at the NAS. No other waterfront facilities or activities were observed during the course of this investigation.

2.3 CLIMATE

The area's climate is characterized by mild winters with hot, humid summers. The average annual temperature in New Orleans is 70°F with monthly means ranging from 57°F in January to 83°F in July and August. The record high temperature is 102°F and the record low temperature is 07°F. The annual average rainfall is 60.8 inches, with normal monthly averages of 3.3 inches in October to 7.3 inches in July. During the summer and autumn months, the area is susceptible to occasional tropical hurricanes.

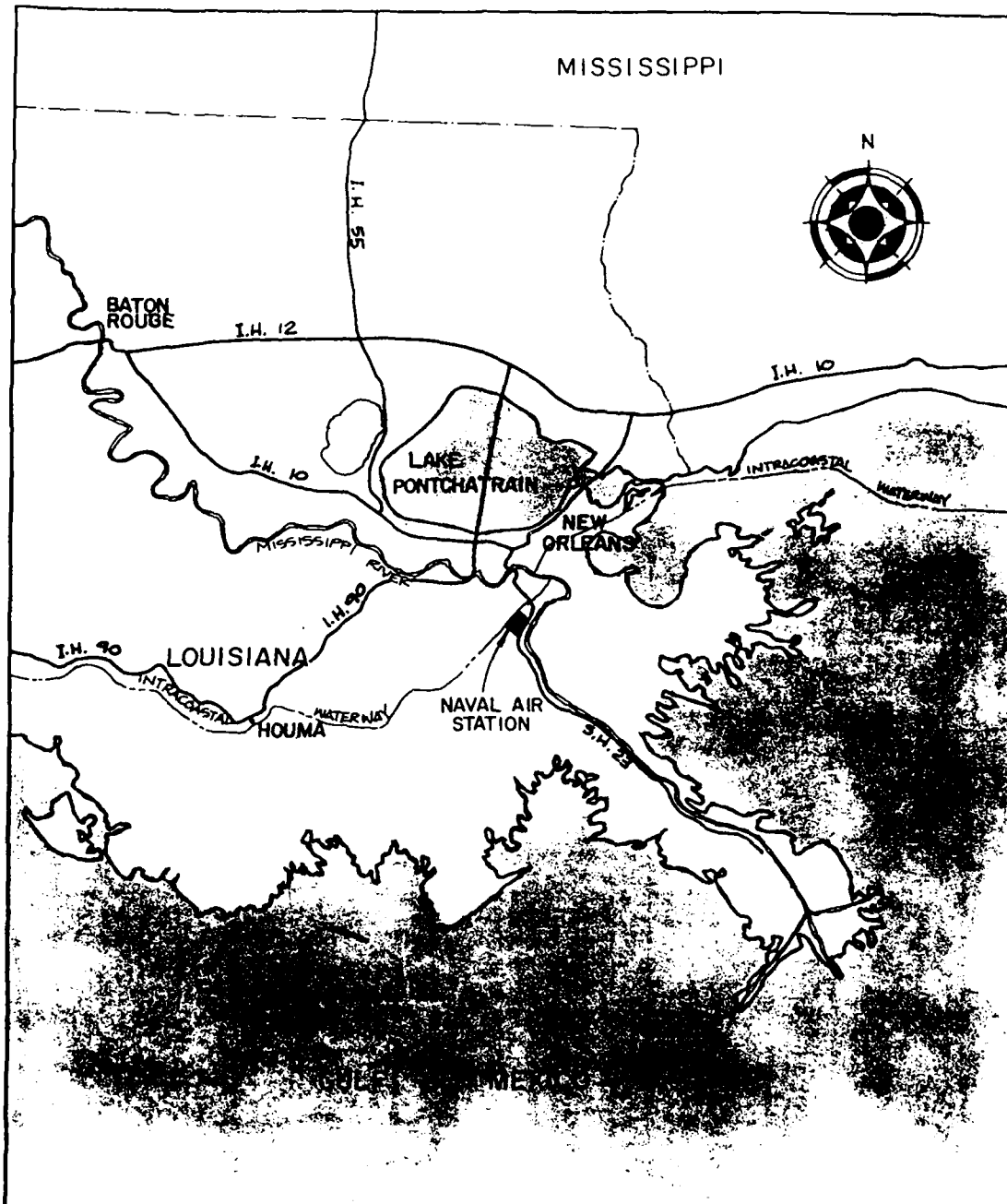

<p>GRAPHIC SCALE</p>	<p>CHESAPEAKE DIVISION NAVAL FACILITIES ENGINEERING COMMAND WASHINGTON, D.C.</p>	<p>FIG. NO.</p>
<p>0 5 10 15 20 25 SCALE IN MILES</p>	<p>OBLETTS ENGINEERING INC. CORPUS CHRISTI, TEXAS</p>	<p>LOCATION MAP</p>

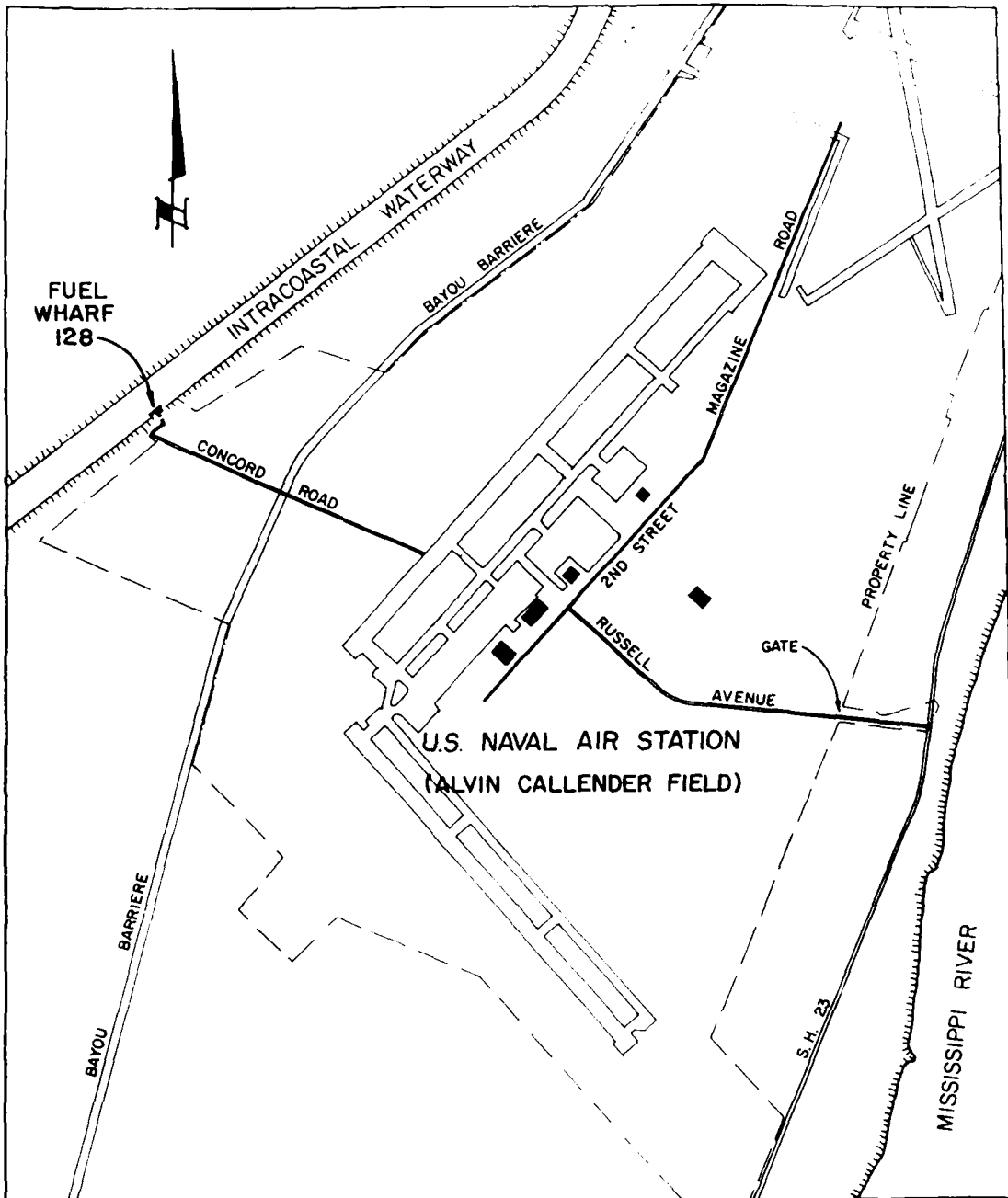

<p>GRAPHIC SCALE</p>	<p>OGLETSE ENGINEERING INC CORPUS CHRISTI, TEXAS</p>	<p>CHESAPEAKE DIVISION NAVAL FACILITIES ENGINEERING COMMAND WASHINGTON, D.C.</p>
<p>0 1000 2000 3000 SCALE IN FEET</p>	<p>NAVAL AIR STATION NEW ORLEANS, LOUISIANA VICINITY MAP</p>	
		<p>FIG NO 2</p>

2.4 TOPOGRAPHY, HYDROLOGY, OCEANOGRAPHIC DATA

The Naval Air Station is in a low lying area ranging from an elevation of -2' to +3' MSL and subject to both fluvial and tidal overflows. The flood plain has been established at elevation 0' MSL. Drainage is provided by an extensive drainage system of open canals and a lift station which pumps into the Intracoastal Canal. The Intracoastal Canal is connected to the Mississippi River by a series of locks, and its water level reportedly does not significantly vary. The Intracoastal Canal and the Mississippi River are both restricted to their banks by man-made levees for flood control.

The field inspection was performed on June 26 and 27, 1985. Methods and levels of examination were in accordance with procedures set forth by the Chesapeake Division, Naval Facilities Engineering Command.

3.1 LEVEL OF EXAMINATION

The level of examination was sufficient to provide data to define the overall condition of the structure, to identify areas needing maintenance, and to suggest general cost effective maintenance/repair procedures. Specific levels of examination as defined by the Chesapeake Division, Naval Facilities Engineering Command and applied to this inspection were:

Level I: General Examination: This type of examination was essentially a "swim-by" overview, which did not involve cleaning of any structural elements, and was therefore conducted much more rapidly than the other levels of examination. The Level I examination should detect obvious major damage or deterioration due to overstress, severe corrosion, or extensive biological growth and attack. The underwater inspector relied primarily on visual and/or tactile observations (depending on water clarity) to make condition assessments. Visual documentation (sketches and/or photographs) was included to support the findings.

A Level I examination was performed on the underwater portions of all structural piles. A significant quantity of the examination effort was to verify "as-built" plans for this report.

Level II: Detailed Examination: This type of examination was directed toward detecting and describing

damaged or deteriorated areas which were hidden by surface biofouling and toward obtaining limited measurements in deterioration. Level II examinations, therefore, required cleaning the structural elements. Since cleaning is extremely time consuming, it was restricted to areas that were specified as most likely to reveal representative general conditions and areas identified during the Level I examination that warranted increased attention.

A Level II examination was specified for approximately 20% of the piles. Level II examination cleaning procedures were specified as follows:

Wood Bearing Piles

Band cleaned around circumference of the pile to a width of ten (10) inches to expose underlying pile at three elevations: mean low water (MLW), mudline (ML), and halfway between MLW and ML. Level II examination for wood piles included measuring minimum pile diameters.

In addition, if an irregular shape or area of apparent distress was detected during the Level I examination, the area was cleaned for more careful examination.

Level III: Highly Detailed Examination: This type of examination involved measuring and/or sampling of the structural elements. The purpose of this type of examination was to quantify hidden damage, loss of cross sectional area, and material condition. Measurements should generally quantify the nature and extent of deterioration.

Level III examination for wood piles included taking wood cores at five percent of the structural piles. Core samples were taken to the center of each pile at three elevations: mean low water (MLW), mudline (ML) and mid-depth MLW and ML. Holes were plugged with preservative treated dowels.

The pattern of the inspection and locations of various levels of examination were determined during the course of the field work, based on the conditions encountered at the structure. More time and detail was spent at areas or locations where deterioration was most likely to be found.

The levels of examination and procedures were flexible to allow modification for particular conditions encountered on the site and to provide for specific needs of each facility.

3.2 INSPECTION PROCEDURE

The inspection was performed by a three man team consisting of an engineer/diver, technician/diver, and a tender/recorder.

The underwater inspection of each pile was a time consuming process. Due to the lack of visibility, the entire surface was inspected tactily, with the inspector/divers carefully feeling the pile to detect breaks, splits, or other irregularities. In addition, the piles were regularly "sounded" with hammers to detect softness. Marine growth was relatively light, consisting primarily of algae, which allowed fairly good interpretation of the underlying timber condition. The tender/recorder provided topside support for the divers, recording data, cataloging core samples and photographs, and transferring tools.

As requested on site, an above water inspection of substructural elements was conducted. This process consisted of visually inspecting and sounding accessible portions of the structural elements to detect decay.

The inspection process included verification of pile counts, structural measurements, and sketches of existing construction where drawings or descriptions were unavailable. Photographs were taken to document conditions encountered during the inspection.

3.3 EQUIPMENT

SCUBA equipment was utilized to maximize mobility. Hand held tools (hammer, hatchet, scraper, etc.) were used for removing marine growth and for hammer sounding the structural elements. Soundings and other measurements were taken with a fiberglass tape.

Underwater photographs were taken with a Nikonos III underwater camera, usually with a 15mm lens and a strobe. Underwater visibility was zero, requiring use of various clear water devices to obtain photographs. Above water photographs were taken with the Nikonos camera using a 35mm lens.

Core samples were taken using a pneumatic drill with a dowel cutter, powered by a portable compressor. All core holes were tightly plugged with treated wood dowels.

This section contains discussion of the Fuel Wharf 128 inspection, presented in four parts:

- A. Description of the type of construction and function of the facility.
- B. Conditions observed and noted during the inspection.
- C. Assessment of the structural condition of the facility.
- D. Recommendations for use, maintenance, repair and operation of the facility with regard to the structural assessment.

4.1 FUEL WHARF 128

4.1.1 Description

Fuel Wharf 128 is a timber structure, constructed on the Intracoastal Canal in approximately 1959. The facility consists of three wharves, with connecting catwalks, an approach ramp, and an electrical pumphouse. A total of 90 creosote treated timber piles support the structure. The wharf provides mooring and unloading facilities for barges which supply aviation fuel utilized at the Naval Air Station. Maximum water depth recorded at the facility during this inspection was 10 feet. (See Figure 3 for Pile Plan and locations of observed inspection conditions. See Figures 4 and 5 for Sections and Construction Details.)

4.1.2 Observed Inspection Conditions

During this investigation, the water level was near the middle of the lower horizontal braces, consequently the underwater inspection was limited to the piling.

The underwater portions of all structural piling were in good condition. No evidence of marine borer activity or significant fungal decay was detected on the surface of any piles or in the extracted cores (See Photos 1, 2, 3, 4, 5 and 6). A water sample collected during the inspection indicated virtually no salinity, a condition in which marine borers cannot survive (See Appendix, Testing Laboratory Report). No significant impact or mechanical damage was detected at any structural pile. There was no evidence to suggest that an impact of sufficient magnitude to fracture a structural pile below the mudline had occurred, although 10 fender piles were broken from impact damage.

Above the waterline, the timber piles were generally structurally sound. Top rot was observed in the exposed tops of three catwalk

INTRACOASTAL WATERWAY

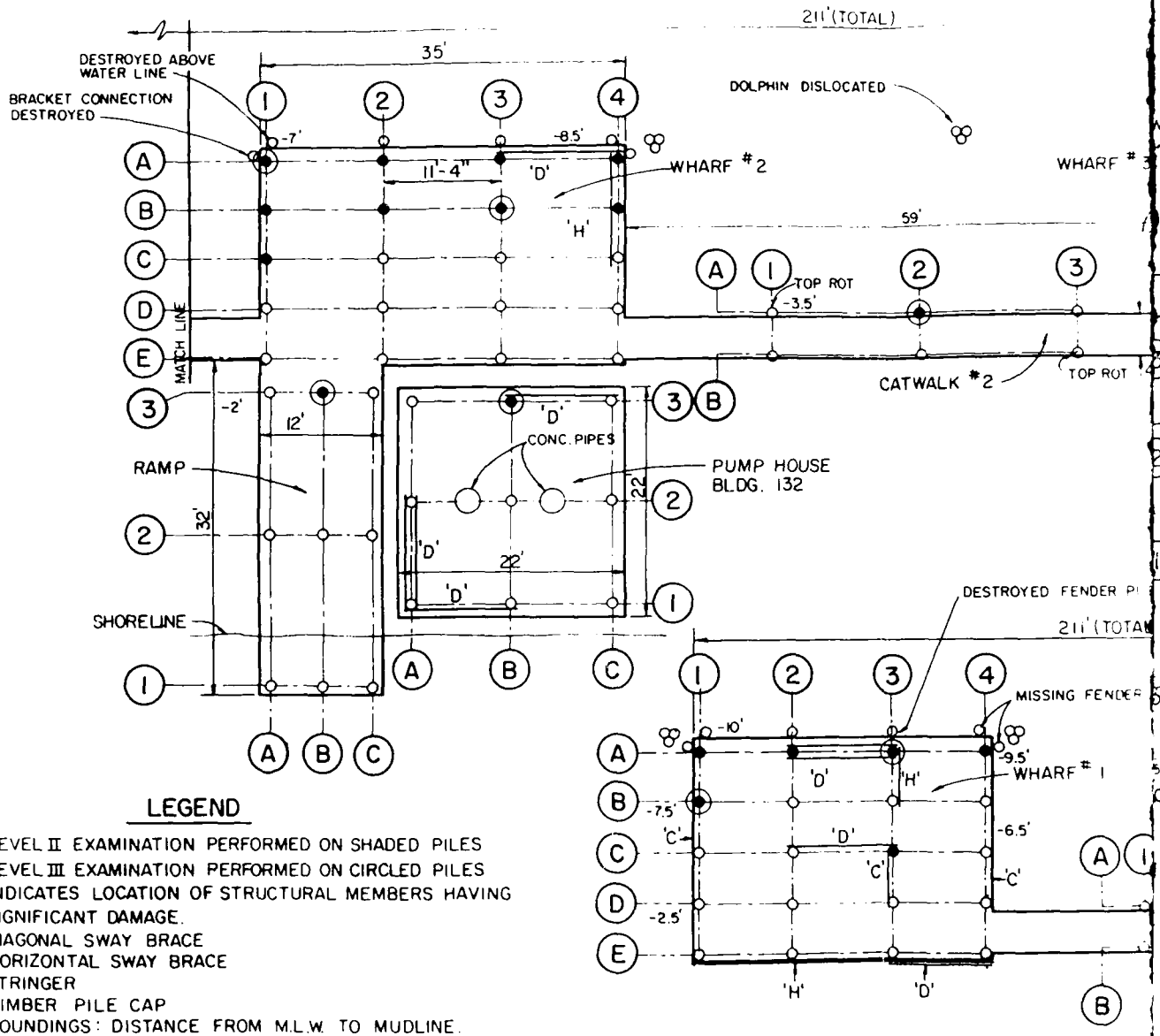

LEGEND

- LEVEL II EXAMINATION PERFORMED ON SHADED PILES
- LEVEL III EXAMINATION PERFORMED ON CIRCLED PILES
- INDICATES LOCATION OF STRUCTURAL MEMBERS HAVING SIGNIFICANT DAMAGE.
- 'D' DIAGONAL SWAY BRACE
- 'H' HORIZONTAL SWAY BRACE
- 'S' STRINGER
- 'C' TIMBER PILE CAP
- 6' SOUNDINGS: DISTANCE FROM M.L.W. TO MUDLINE.

GRAPHIC

0 8

SCALE IN

WATERWAY

211' (TOTAL)

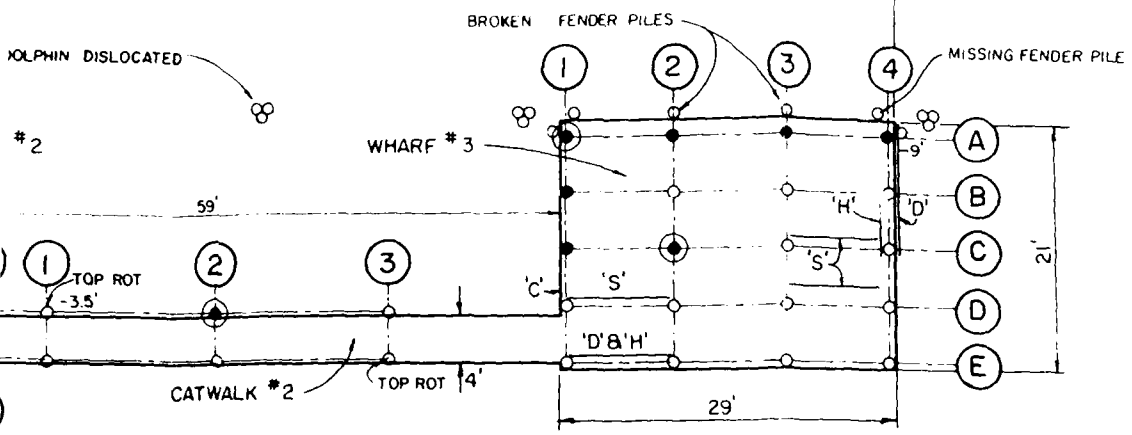

UMP HOUSE
LDG. 132

211' (TOTAL)

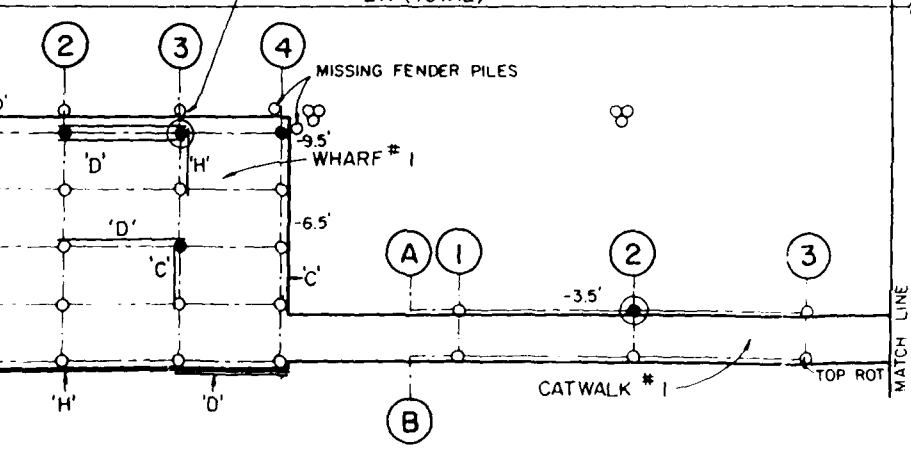

<p>GRAPHIC SCALE</p> <p>SCALE IN FEET</p>	<p>GOLETTREE ENGINEERING INC CORPUS CHRISTI, TEXAS</p>	<p>CHESAPEAKE DIVISION NAVAL FACILITIES ENGINEERING COMMAND WASHINGTON, D.C.</p>	<p>FIG NO 3</p>
		<p>NAVAL AIR STATION NEW ORLEANS LOUISIANA FUEL WHARF 128</p>	

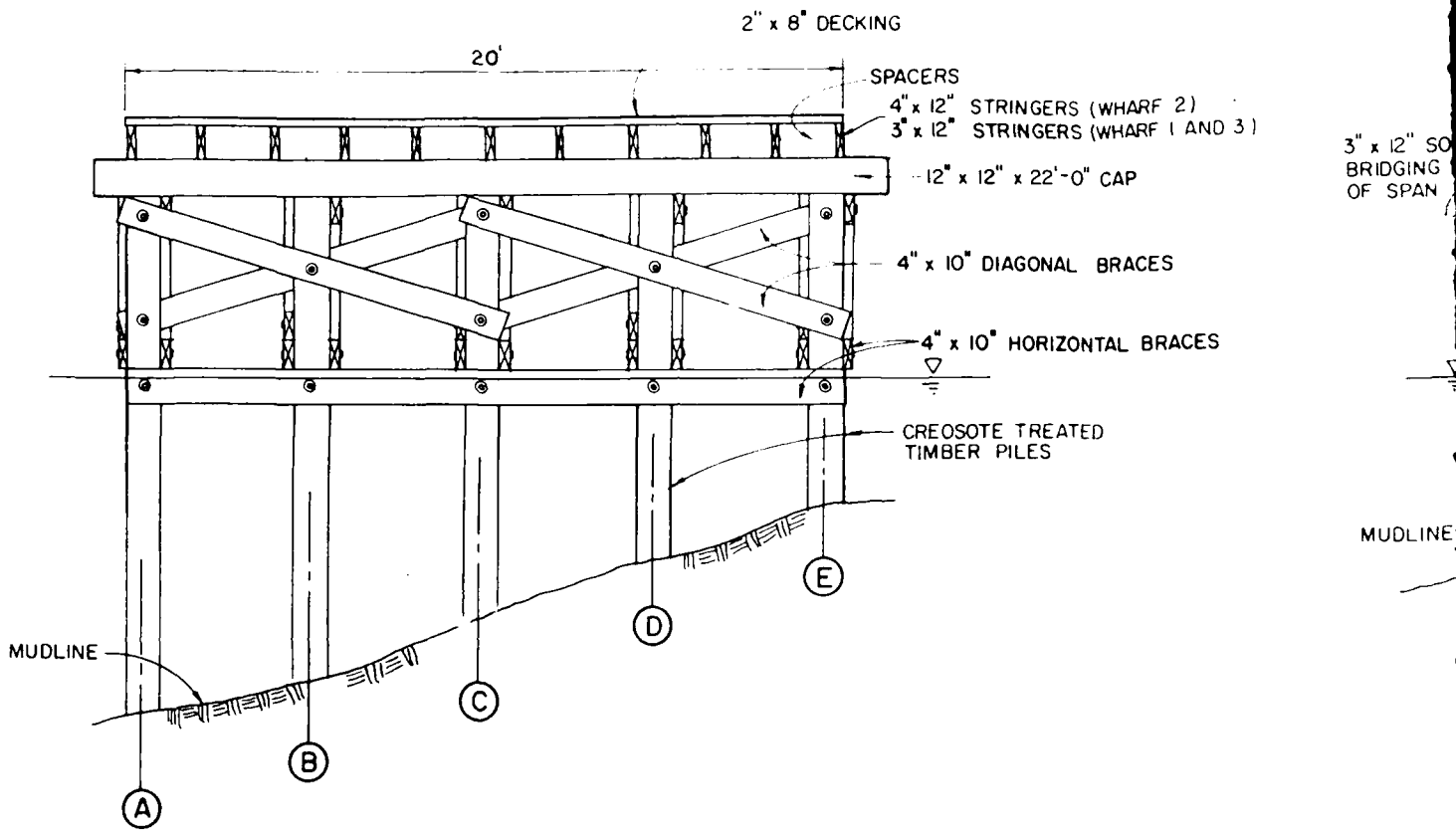

WHARF SECTION

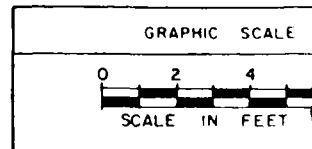

ING

SPACERS

- 4" x 12" STRINGERS (WHARF 2)
- 3" x 12" STRINGERS (WHARF 1 AND 3)

12" x 12" x 22'-0" CAP

4" x 10" DIAGONAL BRACES

4" x 10" HORIZONTAL BRACES

CREOSOTE TREATED TIMBER PILES

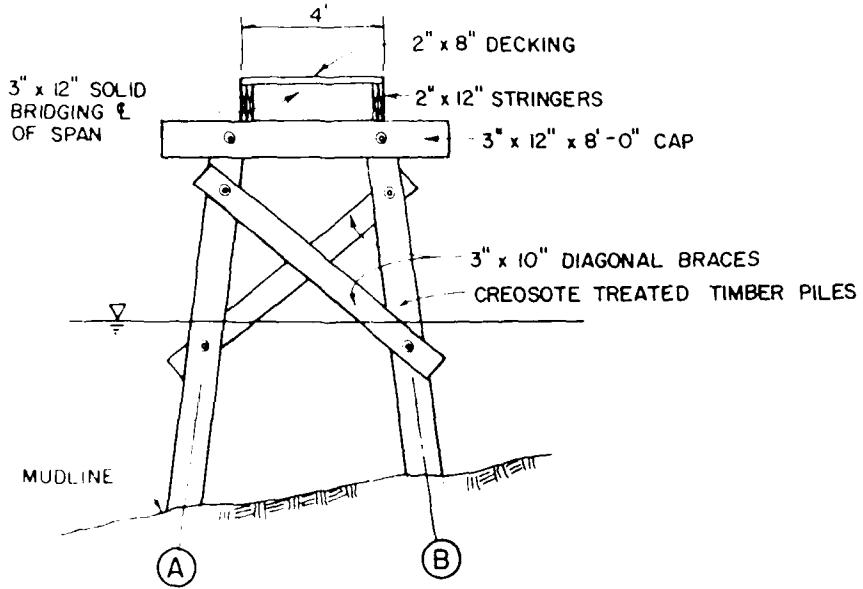

CATWALK SECTION

<p>GRAPHIC SCALE</p> <p>SCALE IN FEET</p>	<p>OGLETREE ENGINEERING INC CORPUS CHRISTI, TEXAS</p>	<p>CHESAPEAKE DIVISION NAVAL FACILITIES ENGINEERING COMMAND WASHINGTON, D.C.</p>	<p>FIG NO</p>
		<p>NAVAL AIR STATION NEW ORLEANS, LOUISIANA FUEL WHARF 128</p>	<p>4</p>

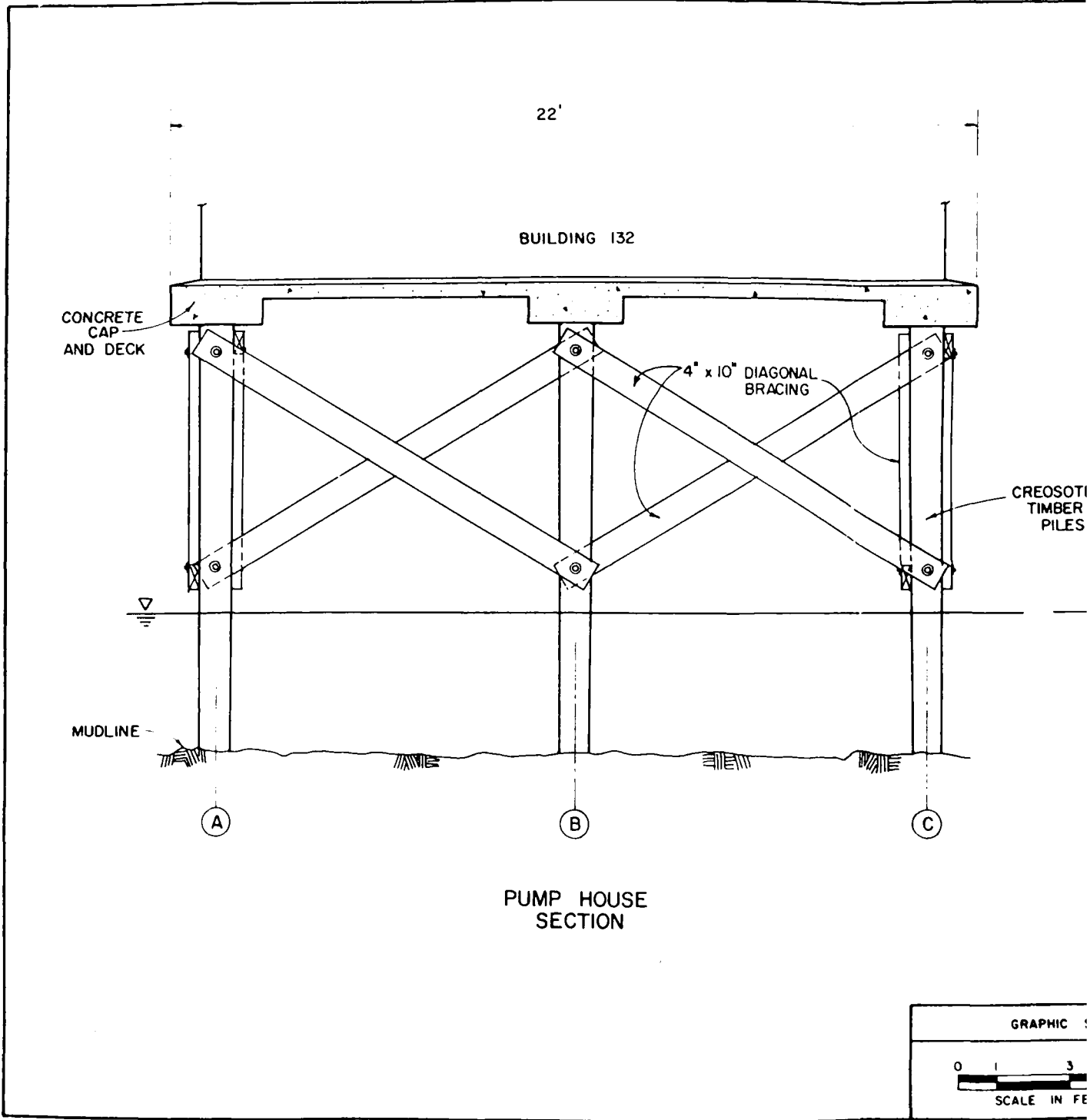

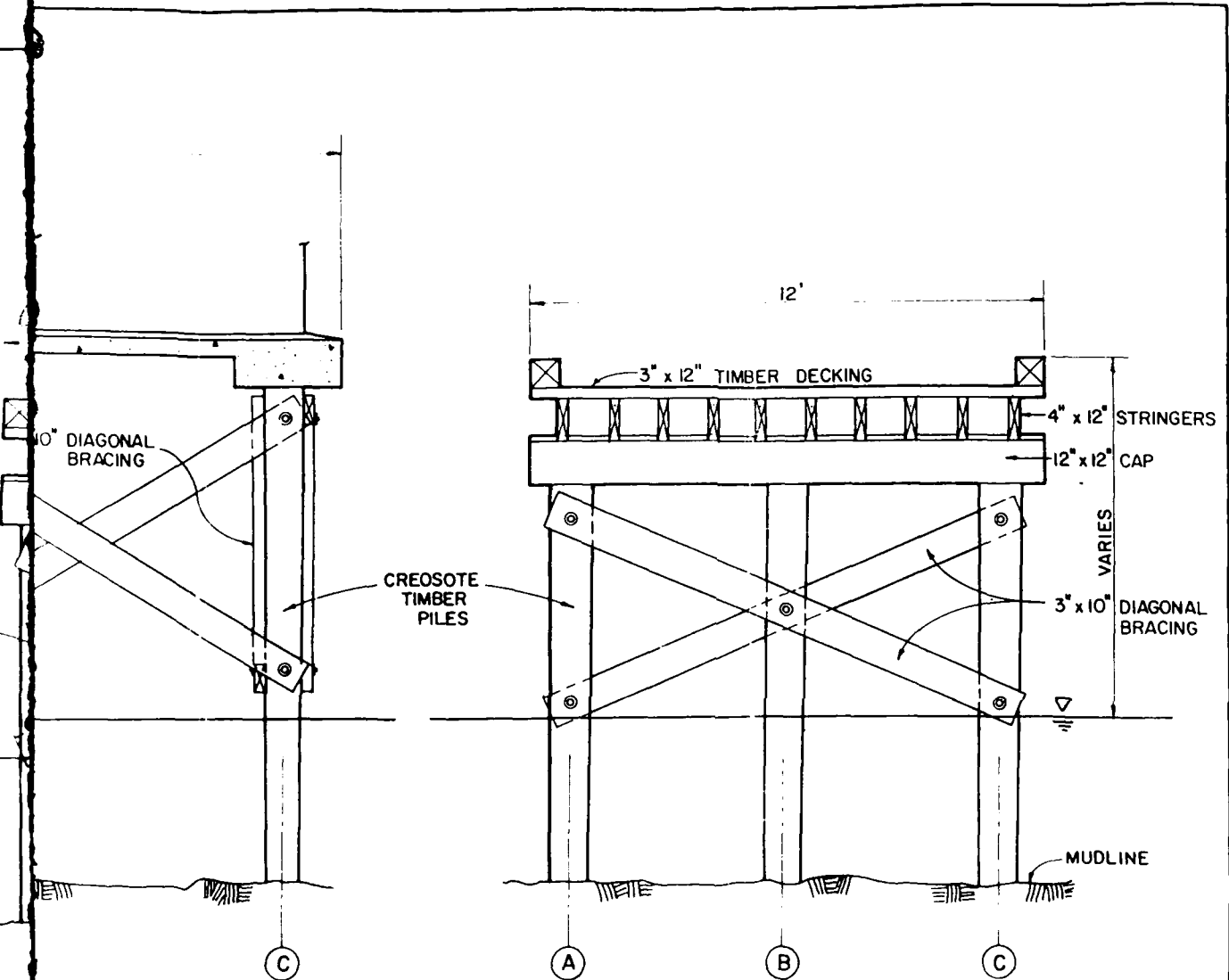

RAMP SECTION

<p>GRAPHIC SCALE</p> <p>SCALE IN FEET</p>	<p>OGLETREE ENGINEERING INC. CORPUS CHRISTI, TEXAS</p>	<p>CHESAPEAKE DIVISION NAVAL FACILITIES ENGINEERING COMMAND WASHINGTON, D.C.</p>	
		<p>NAVAL AIR STATION NEW ORLEANS, LOUISIANA</p>	<p>FIG NO 5</p>

FJEL WHARF 128

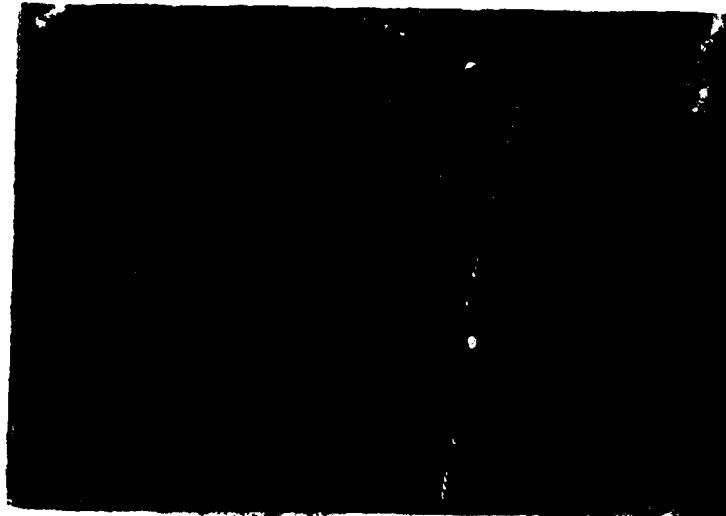

PHOTO 1

Underwater photograph of uncleaned Pile 1A,
Wharf 2, showing typical marine growth.

PHOTO 2

Close up underwater photograph of typical marine
growth.



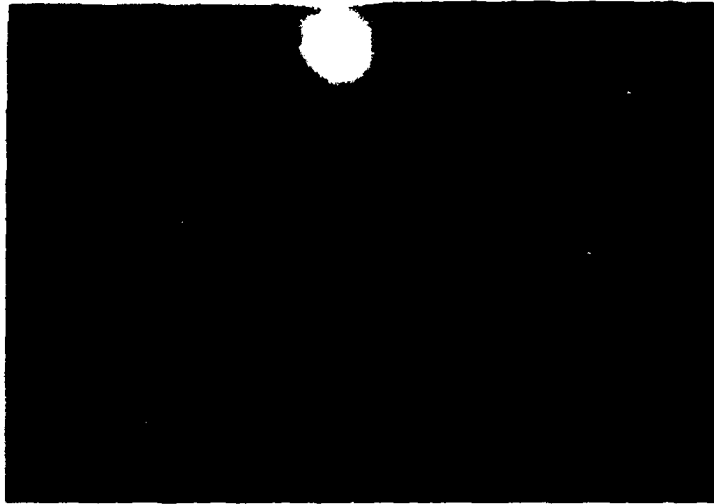

PHOTO 3

Underwater photograph of cleaned Pile 1A, Wharf 2, showing timber surface after removal of marine growth.

PHOTO 4

Close up underwater photograph of cleaned timber surface shown in Photograph 3.

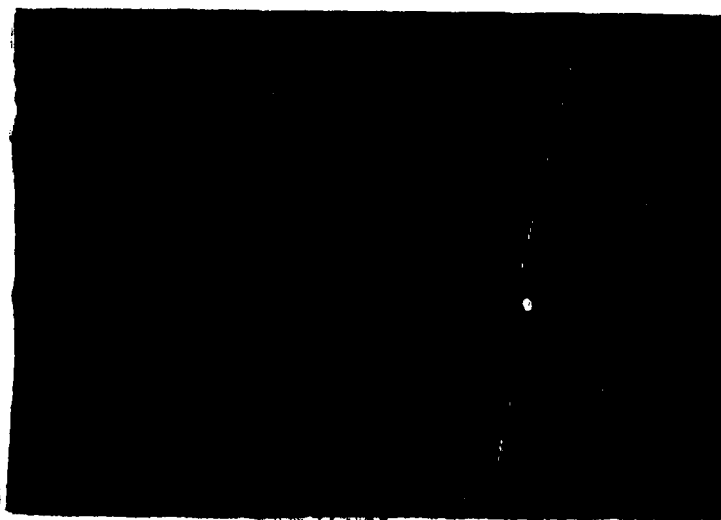

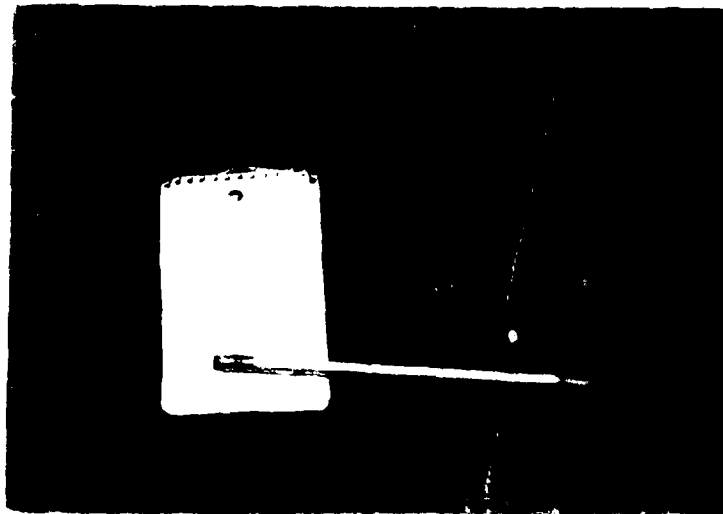

PHOTO 5

Close up underwater photograph of plugged core holes at Wharf 3, Pile 1A. Plug is 3/4" diameter treated wood dowel.

PHOTO 6

Showing cores extracted from Wharf 3, Pile 1A.



piles where moisture could penetrate the unprotected wood (See Photo 7). Most pile tops were covered by structural framing and fungal decay could not be detected from exterior inspection.

The overall condition of the structural members was good, although fungal decay was detected at locations throughout the facility. Structural framing consists of two rows of horizontal bracing, diagonal bracing, pile caps, stringers, spacers between stringers, and deck (See Figure 4). All timber framing was creosote treated. The deck appeared to have the greatest number of decayed members, with an estimated 30% showing areas of significant decay (See Photo 8). Although the deck covered the top of the stringers, possibly obscuring some deterioration, decayed areas were noted in approximately 5% of the stringers (See Photos 9 and 10). The caps were the most extensively decayed members. Deterioration of the cap members usually occurred in the horizontal surfaces where moisture could accumulate. Three outer caps and one interior cap exhibited deterioration (See Photos 11 and 12). It should be noted that many areas where decay could occur were obstructed by framing members. For example, the upper portions of the stringers were covered by the deck, and the caps were covered by stringers, spacers, and the deck.

Another "trouble spot" appeared to be at the stringer-spacer-cap intersection, where a moisture trap was created. Access to this area was very limited, and the extent of damage was difficult to determine.

An estimated 10% of the stringers, diagonal bracing, and horizontal bracing exhibited decayed areas (See Photos 13, 14, 15 and 16). Decay was generally limited to a relatively small section of an affected member. Two diagonal braces on the front row of Wharf #1 had been broken up by impact damage (See Photo 17).



PHOTO 7

Catwalk 2, Pile 3B, 'Top Rot'. Decay penetrates approximately 18".

PHOTO 8

Wharf 3, typical appearance of decayed deck member.



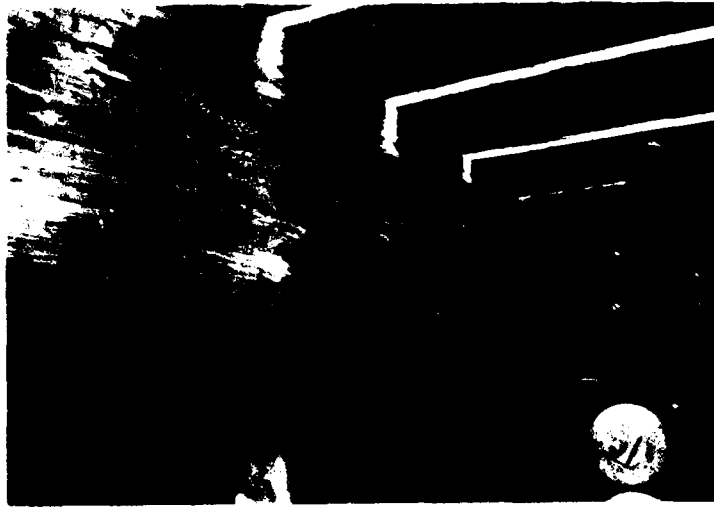

PHOTO 9

Decayed stringer at Wharf 3, between Bents 3 and 4,
Rows B and C.

PHOTO 10

Decayed stringer at Wharf 3, between Bents 1 and 2,
Rows C and D.



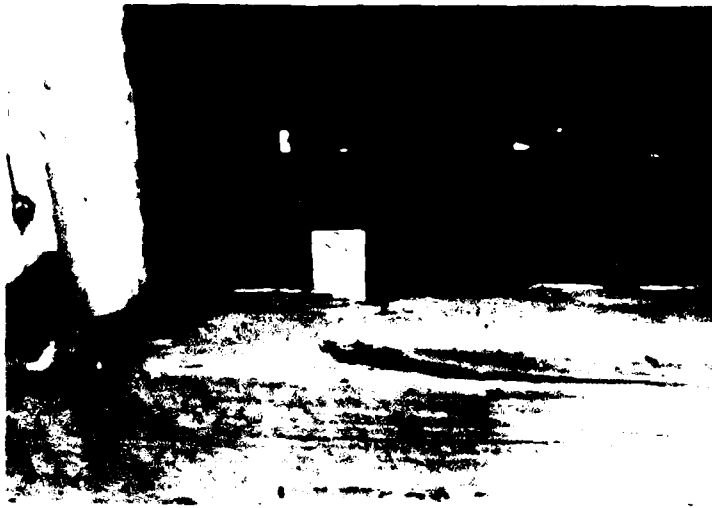

PHOTO 11

Decayed cap at Wharf 1, Bent 4 near Row D.

PHOTO 12

Decayed cap at Wharf 1, Bent 3 between Rows C and D.





PHOTO 13

Decayed diagonal brace at Wharf 3, Pile 1E.

PHOTO 14

Decayed diagonal brace at Pump Station, between
Bents 1 and 2, Row A.





PHOTO 15

Decayed horizontal brace at Pump Station, between
Bents 1 and 2, Row A.

PHOTO 16

Decayed horizontal brace at Wharf 3, Bent 4,
between Rows B and C.



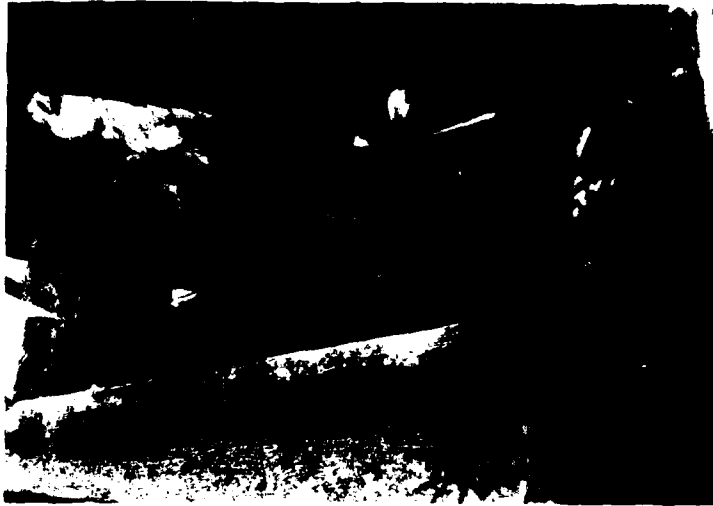

PHOTO 17

Showing broken diagonal bracing at Wharf 1, Row A,
between Bents 2 and 3.

PHOTO 18

Showing typical extensive bracing and heavy con-
struction of wharf.



Connections were found to be very tight and secure. Connecting hardware was in very good condition, with only minor corrosion.

A non-structural problem was observed and is mentioned as requested. A fire water intake pipe beneath Wharf #3 was severely pitted and corroded, and leaking in at least one location.

4.1.3 Structural Condition Assessment

In spite of the fairly common widespread fungal decay, the structural condition of Wharf 128 is good. Two reasons for this assessment are:

- A. The wharf is very heavily constructed. All timbers are large, bracing is extensive, and connections are well made.
- B. The wharf is lightly loaded. There is no vehicle traffic on the wharf, so live loads are minimal. The most significant loads are from breasting and mooring barges, which are absorbed through the extensive bracing system and the elastic movement of the timber structure.

For these reasons, the extent of existing fungal decay does not present a severe structural problem.

4.1.4 Recommendations

A replacement program for deteriorated timber should be implemented. First, deteriorated timber deck members should be removed. In addition, it is recommended that deck members, immediately above the caps be removed. This will allow access to the stringer spacers, which tend to create traps for moisture in their present position on top of the caps. When the spacers are exposed by removing the deck, they should be removed and replaced with new pieces in positions between the caps.

Removal of the deck will probably reveal additional areas of deterioration in stringers and caps, which can be replaced on a selective basis.

Replacing cap members would require virtual disassembly of the superstructure. Therefore, depending on the extent of the decay, it would be desirable to repair the damaged sections by removing decayed material and refilling the voids with filler material such as epoxy grout. In some cases, where decay has not destroyed more than 50% of a section, or where decay is limited to an isolated area of a particular member, a decayed section may be spanned by spliced sections (See Figure 6). Application of moisture barriers and preservative to exposed locations would prolong the structural integrity. Top rot in timber piles should be repaired by a similar procedure. Rotten material should be removed, the void refilled and the top sealed to prevent moisture intrusion. Diagonal and horizontal braces indicated on Figure 3 should be replaced. It is often convenient to utilize the removed damaged member as a pattern for cutting the bolt holes in the replacement member. It is expected that most existing connection hardware can be re-used, but some hardware replacement will be necessary. Estimated cost to repair or replace damaged structural timbers is \$36,000 (See Appendix, Cost Estimate Calculations).

Damaged bracing that is typically submerged should be replaced with timber treated to maximum preservative retention. All replacement timber should be treated in accordance with American Wood Preservers specifications. The broken and missing piles and timber in the fender system should be replaced. Gaps in the fender system leave the structure vulnerable to impact damage from vessels. This type of fender system characteristically suffers impact damage and required periodic repair.

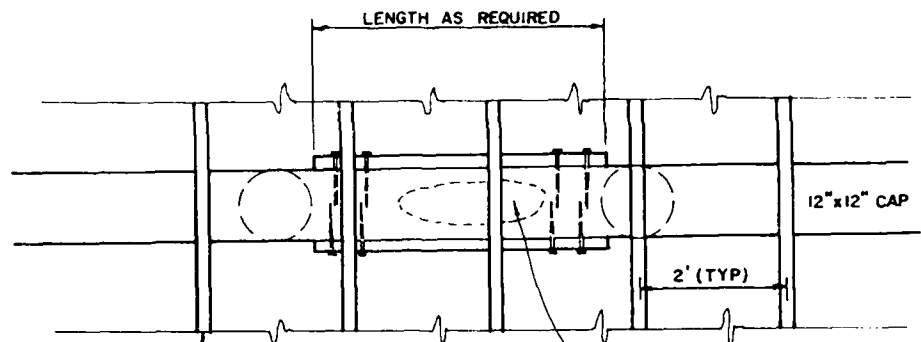

PLAN
(DECK REMOVED FOR CLARITY)

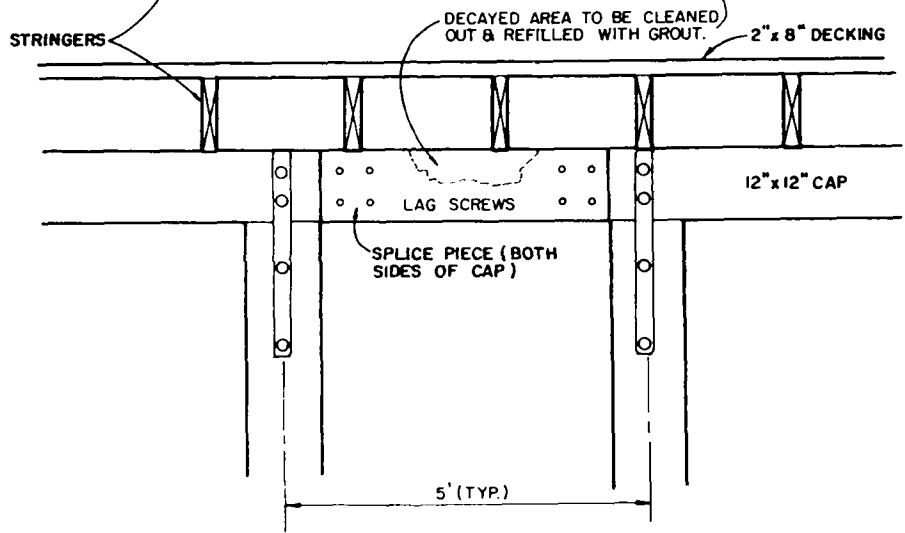

SECTION

<p>GRAPHIC SCALE</p>	<p>OOLETEE ENGINEERING INC CORPUS CHRISTI, TEXAS</p>	<p>CHESAPEAKE DIVISION NAVAL FACILITIES ENGINEERING COMMAND WASHINGTON, D.C.</p>	<p>FIG. NO. 6</p>
<p>0 1 2 3 SCALE IN FEET</p>	<p>NAVAL AIR STATION NEW ORLEANS, LOUISIANA CONCEPTUAL CAP REPAIR</p>		

TABLE OF CONTENTS FOR APPENDIX

<u>TITLE</u>	<u>PAGE</u>
SALINITY ANALYSIS, LABORATORY REPORT	A - 2
COST ESTIMATE CALCULATIONS	A - 3
STRUCTURAL CALCULATIONS.	A4 - A5

GULF COAST



TESTING LABORATORY, INC.

1205 NORTH TANCAHUA STREET

CORPUS CHRISTI, TEXAS 78401-1409 • (512) 882-5411

PROJECT Water Sample
 FOR Ogletree, Bryan, Welch & Hubner
 REPORTED TO Same
 Attention Mr Stan Russell

REPORT DATE July 15, 1985
 CLIENT NO. 16070000
 JOB NO. 850034
 LAB NO. 78528-1W
 SAMPLE DESCRIPTION N.O., LA NAS
Fuel Wharf 128
 DATE SAMPLED June 27, 1985
 TIME SAMPLED P.M.
 SAMPLED BY Client
 REC. IN LAB 7-11-85
 TIME 7:50AM BY SSW
 PICKED UP DEL. X

RESULTS OF ANALYSIS NO. 07061

CODE	ANALYSIS	UNITS	RESULTS	METHOD #	TIME	DATE	ANALYST
20111	Salinity	ppm	354	210B	1:00PM	7-12	SSW

SS :rs

*STANDARD METHODS FOR THE ANALYSIS OF WATER AND WASTEWATER, 16TH EDITION, UNLESS NOTED OTHERWISE

COMMENTS:

VIEWED

Sonia S. Wallis
 Chemist

A-2

Resally Owned and Operated

COST ESTIMATE CALCULATIONS

FUEL WHARF 128, TIMBER FRAMING REPLACEMENT

MATERIAL:

Creosote Treated Timber, \$800/MBF
Approximately 8 MBF of timber required to replace
deteriorated members
8 MBF X \$800/MBF \$ 6,400
Miscellaneous hardware, flashing and fasteners 1,600
Estimated Material Cost \$ 8,000

LABOR:

Project is "labor intensive". Estimated cost for
crew time with necessary equipment (compressor,
work float, scaffolding, tools) for removal of
decayed timber, selective replacement and splicing
is approximately 3.5 times material cost.

\$8,000 (material cost) x 3.5 (labor cost factor) = \$28,000

TOTAL ESTIMATED COST..... \$36,000

STRUCTURAL CALCULATIONS

SAFE LOADS FOR TIMBER PILES

$$L/d \leq 11 \quad P = A \cdot C$$

$$11 < L/d < K \quad P = A \cdot C \left[1 - \frac{1}{3} \left(\frac{L}{Kd} \right)^4 \right]$$

$$L/d \geq K \quad P = 3.29 \times 10^{-4} E \cdot A / (L/d)^2$$

P = SAFE LOAD (KIPS) ($P \approx P_R \div 25$ SAFETY FACTOR AS DETERMINED BY $P_R = \pi^2 EI / L^2$)

A = CROSS SECTIONAL AREA (IN^2), USING EFFECTIVE $d = 10'$ PILE,
 $\pi d^2/4 = 78.5 \text{ IN}^2$

E = MODULUS OF ELASTICITY (#/IN^2), $1.6 \times 10^6 \text{ #/IN}^2$

L = UNSUPPORTED LENGTH (IN)

d = LEAST DIMENSION (IN), USED EQUIVALENT SQUARE TIMBER
 DIMENSION FOR ROUND COLUMN, $d = \sqrt{A} = 8.86 \text{ IN}$

L/d = SLENDERNESS RATIO (IN/IN)

I = MOMENT OF INERTIA (IN^4), $I = \pi d^4/64 = 490.87 \text{ IN}^4$, d = DIAMETER

C = SAFE UNIT COMPRESSIVE STRESS PARALLEL TO THE GRAIN, $C \approx .875 \text{ #/IN}^2$

K = SLENDERNESS RATIO CONSTANT FOR GIVEN SPECIES, GRADE,
 AND CONDITION OF SERVICE; VALUE OBTAINED IS THE MINIMUM
 VALUE COLUMN WILL BEHAVE AS AN EULER COLUMN (FAILURE
 AS A RESULT OF BUCKLING), WHEN $P/A = 2C/3$ $K = \pi/2 \sqrt{E/3C}$
 $K = 30$

SAMPLE CALCULATION: FIND SAFE LOAD FOR COLUMN, $L = 30'$

$$K = \pi/2 \sqrt{E/3C} = \pi/2 \sqrt{1.6 \times 10^6 / 3(875)} = 30$$

$$L/d = 30'(12'/1') / 8.86' = 40.63$$

$$\therefore P = 3.29 \times 10^{-4} E \cdot A / (L/d)^2$$

$$= 3.29 \times 10^{-4} (1.6 \times 10^6) (78.5) / (40.63)^2$$

$$P = 25 \text{ KIPS}$$

TABLE OF SAFE LOADS FOR VARIOUS UNSUPPORTED LENGTHS

UNSUPPORTED LENGTH (L)	SLENDERNESS RATIO (L/D)	SAFE LOAD (P IN KIPS)
10' = 120"	13.54	67.7
20' = 240"	27.08	51.8
30' = 360"	40.63	25.0

REFERENCES. WOOD ENGINEERING GERMAN GURFINKEL
SOUTHERN PINE MANUAL OF STANDARD WOOD CONSTRUCTION,
SOUTHERN PINE ASSOCIATION

END

DATE
FILMED

7-86

DTIC