

AD-A168 736

DYNAMIC TEST OF A CORRUGATED STEEL KEYHOLE BLAST  
SHELTER(U) ARMY ENGINEER WATERWAYS EXPERIMENT STATION  
VICKSBURG MS STRUCTURES LAB S C WOODSON ET AL. MAY 86  
MES/TR/SL-86-6 F78 13/13

1/1

UNCLASSIFIED

ML

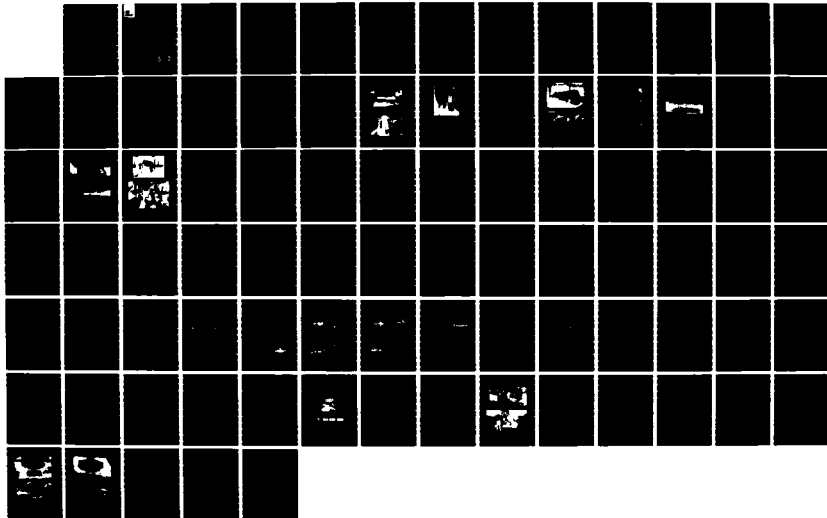

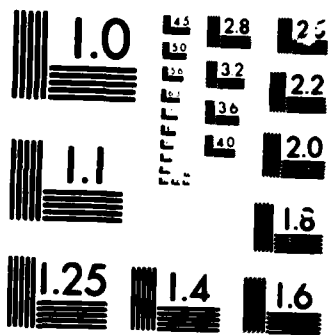

MICROCOPY

CHART

12

TECHNICAL REPORT SL-86-6

# DYNAMIC TEST OF A CORRUGATED STEEL KEYWORKER BLAST SHELTER

by

Stanley C. Woodson, Thomas R. Slawson,  
and Randy L. Holmes

Structures Laboratory

DEPARTMENT OF THE ARMY  
Waterways Experiment Station, Corps of Engineers  
PO Box 631, Vicksburg, Mississippi 39180-0631



Final Report  
May 1986

DTIC FILE COPY

DTIC  
ELECTE  
JUN 18 1986  
S D

Department of the Army  
Washington, DC 20315

86 6 18 016



US Army Corps  
of Engineers

AD-A168 736



TECHNICAL REPORT SL-86-6

# DYNAMIC TEST OF A CORRUGATED STEEL KEYWORKER BLAST SHELTER

by

Stanley C. Woodson, Thomas R. Slawson,  
and Randy L. Holmes

Structures Laboratory

DEPARTMENT OF THE ARMY  
Waterways Experiment Station, Corps of Engineers  
PO Box 631, Vicksburg, Mississippi 39180-0631

Final Report  
May 1986

Approved for public release; distribution unlimited

This report has been reviewed in the Federal Emergency Management Agency and approved for publication. Approval does not signify that the contents necessarily reflect the views and policies of the Federal Emergency Management Agency.

Prepared for

Federal Emergency Management Agency  
Washington, DC 20472

## **Dynamic Test of a Corrugated Steel Keyworker Blast Shelter**

At the time this study was initiated, civil defense planning in the United States called for the evacuation of nonessential personnel to safe host areas when a nuclear attack is probable, requiring the construction of blast shelters to protect the key workers remaining in the risk areas. A full-scale corrugated steel Keyworker blast shelter was dynamically tested using the High Explosive Simulation Technique (HEST). The test primarily investigated the structural design of the shelter and entryway, survivability of the air-moving system components (generator, blower, and intake and exhaust systems), and occupant survivability. Alternate blast closure designs for the 18-man shelter were also tested.

The test showed that the structure can withstand a 55-psi peak overpressure loading from a 1-MT nuclear detonation with only minor damage. Permanent diameter changes of the 9-foot-diameter shelter were approximately 0.6 to 0.8 inch. Rigid-body displacements were limited to less than 0.5 inch. A high-speed movie camera monitored the movement of three instrumented mannequins, and analysis of the film indicated that impact injuries of occupants are not probable. Also, shock spectra based on acceleration data recorded during the test show that in-structure shock is within acceptable limits for occupants. Typical floor-mounted shelter equipment (generators and communication devices) should be isolated on pads to ensure survivability.

TECHNICAL REPORT SL-86-6

# DYNAMIC TEST OF A CORRUGATED STEEL KEYWORKER BLAST SHELTER

by

Stanley C. Woodson, Thomas R. Slawson,  
and Randy L. Holmes

Structures Laboratory

DEPARTMENT OF THE ARMY  
Waterways Experiment Station, Corps of Engineers  
PO Box 631, Vicksburg, Mississippi 39180-0631

Final Report  
May 1986

*Approved for public release; distribution unlimited*

*This report has been reviewed in the Federal Emergency Management Agency and approved for publication. Approval does not signify that the contents necessarily reflect the views and policies of the Federal Emergency Management Agency.*

Prepared for

Federal Emergency Management Agency  
Washington, DC 20472

Unclassified

SECURITY CLASSIFICATION OF THIS PAGE (When Data Entered)

REPORT DOCUMENTATION PAGE		READ INSTRUCTIONS BEFORE COMPLETING FORM
1. REPORT NUMBER Technical Report SL-86-6	2. GOVT ACCESSION NO. ADA 168 736	3. RECIPIENT'S CATALOG NUMBER
4. TITLE (and Subtitle)  DYNAMIC TEST OF A CORRUGATED STEEL KEYWORKER BLAST SHELTER	5. TYPE OF REPORT & PERIOD COVERED Final report	
	6. PERFORMING ORG. REPORT NUMBER	
7. AUTHOR(s)  Stanley C. Woodson, Thomas R. Slawson, and Randy L. Holmes	8. CONTRACT OR GRANT NUMBER(s)	
9. PERFORMING ORGANIZATION NAME AND ADDRESS US Army Engineer Waterways Experiment Station Structures Laboratory PO Box 631, Vicksburg, Mississippi 39180-0631	10. PROGRAM ELEMENT, PROJECT, TASK AREA & WORK UNIT NUMBERS	
11. CONTROLLING OFFICE NAME AND ADDRESS  Federal Emergency Management Agency Washington, DC 20472	12. REPORT DATE May 1986	
	13. NUMBER OF PAGES 79	
14. MONITORING AGENCY NAME & ADDRESS (if different from Controlling Office)	15. SECURITY CLASS. (of this report) Unclassified	
	15a. DECLASSIFICATION/DOWNGRADING SCHEDULE	
16. DISTRIBUTION STATEMENT (of this Report)  Approved for public release; distribution unlimited.		
17. DISTRIBUTION STATEMENT (of the abstract entered in Block 20, if different from Report)		
18. SUPPLEMENTARY NOTES  Available from the National Technical Information Service, 5285 Port Royal Road, Springfield, Virginia 22161.		
19. KEY WORDS (Continue on reverse side if necessary and identify by block number)  Blast shelter                      Dynamic testing → Buried shelter                  Key worker Corrugated steel		
20. ABSTRACT (Continue on reverse side if necessary and identify by block number)  → At the time this study was initiated, civil defense planning in the United States called for the evacuation of nonessential personnel to safe host areas when a nuclear attack is probable, requiring the construction of blast shelters to protect the key workers remaining in the risk areas. A full-scale corrugated steel Keyworker blast shelter was dynamically tested using the High Explosive Simulation Technique (HEST). The test primarily investigated the structural design of the shelter and entryway, survivability of the air-moving system components, and occupant survivability. Alternate blast designs for the 18-man shelter were also tested. (Continued)		

Unclassified

SECURITY CLASSIFICATION OF THIS PAGE(When Data Entered)

20. ABSTRACT (Continued).

> The test showed that the structure can withstand a 55-psi peak overpressure loading from a 1-MT nuclear detonation with only minor damage. In-structure shock was within acceptable limits for occupants. However, typical floor-mounted shelter equipment should be shock-isolated with pads to ensure survivability. Structural modifications to decrease the cost and increase the ease of installation of the structure are recommended.

Regards:

FED

Unclassified

SECURITY CLASSIFICATION OF THIS PAGE(When Data Entered)

## PREFACE

The research reported herein was sponsored by the Federal Emergency Management Agency (FEMA) through the US Army Engineer Division, Huntsville (HND) in support of the Keyworker Blast Shelter Test Program. Mr. Tom Provenzano, FEMA, was the Program Monitor.

The test was conducted by personnel of the Structures Laboratory (SL), US Army Engineer Waterways Experiment Station (WES), under the general supervision of Mr. Bryant Mather, Chief, SL; Mr. J. T. Ballard, Assistant Chief, SL; Dr. J. P. Balsara, Chief, Structural Mechanics Division (SMD), SL; and under the direct supervision of Dr. S. A. Kiger of the Research Group, SMD. The field test was supervised by Mr. R. L. Holmes of the Research Group, SMD, and instrumented by Mr. Phil Parks, Instrumentation Services Division, WES. This report was prepared by Messrs. S. C. Woodson, T. R. Slawson, and R. L. Holmes, Research Group, SMD, and edited by Mr. R. A. Baylot, Jr., Publications and Graphic Arts Division, WES.

Director of WES was COL Allen F. Grum, USA; Technical Director was Dr. Robert W. Whalin.

Accession For	
NTIS CRA&I	<input checked="" type="checkbox"/>
DTIC TAB	<input type="checkbox"/>
Unannounced	<input type="checkbox"/>
Justification	
By	
Distribution /	
Availability Codes	
Dist	Availability for Special
A-1	



# CONTENTS

	<u>Page</u>
PREFACE .....	1
LIST OF ILLUSTRATIONS .....	3
LIST OF TABLES .....	4
CONVERSION FACTORS, NON-SI TO SI (METRIC) UNITS OF MEASUREMENT .....	5
CHAPTER 1 INTRODUCTION .....	6
1.1 Background .....	6
1.2 Objectives .....	6
1.3 Scope .....	6
CHAPTER 2 TEST DESCRIPTION .....	8
2.1 Test Element Construction Details .....	8
2.2 Test Configuration and Placement Details .....	8
2.3 Instrumentation .....	9
2.4 High-Speed Photography .....	9
2.5 Backfill Material Properties .....	10
CHAPTER 3 TEST RESULTS .....	21
3.1 Damage .....	21
3.2 Recovered Data .....	21
CHAPTER 4 DATA ANALYSIS .....	24
4.1 Nuclear Weapon Simulations .....	24
4.2 High-Speed Movie Data Reduction .....	24
4.3 In-Structure Shock .....	24
CHAPTER 5 CONCLUSIONS AND RECOMMENDATIONS .....	35
5.1 Conclusions .....	35
5.2 Recommendations .....	35
REFERENCES .....	36
APPENDIX A CONSTRUCTION DETAILS .....	37
APPENDIX B TEST DATA .....	43
APPENDIX C NUCLEAR WEAPON SIMULATIONS .....	59
APPENDIX D OAK RIDGE NATIONAL LABORATORY CLOSURES ..	65

## LIST OF ILLUSTRATIONS

<u>Figure</u>		<u>Page</u>
2.1	Expedient shelter without entryway at test site .....	13
2.2	View of shelter's facilities .....	13
2.3	Close-up of generator area .....	14
2.4	Test configuration .....	15
2.5	Placement of structure in test bed .....	16
2.6	Sand backfill .....	16
2.7	Charge cavity construction .....	17
2.8	Charge cavity .....	17
2.9	Completed overburden placement .....	18
2.10	Instrumentation locations .....	19
2.11	Strain gages over entryway .....	20
2.12	Instrumented mannequins .....	20
3.1	Displacement of overburden during test .....	22
3.2	Overburden and charge cavity debris (posttest) .....	22
3.3	Mannequins inside shelter .....	23
4.1	Displacement versus time plot for mannequin in standing position .....	27
4.2	Horizontal displacement versus time plot for mannequin in sitting position .....	28
4.3	Vertical displacement versus time plot for mannequin in sitting position .....	29
4.4	Displacement versus time plot for mannequin in supine position .....	30
4.5	Predicted shock spectra .....	31
4.6	Vertical shock spectra from accelerometer A6 .....	32
4.7	Vertical shock spectra from accelerometer A9 .....	33
4.8	Comparison of experimental shock spectra with response spectra for typical floor-mounted equipment .....	34
D.1	Closure tested on structure .....	67
D.2	Closure on entryway of shelter .....	68
D.3	Item 1 .....	69

<u>Figure</u>	<u>Page</u>
D.4 Item 1 in test bed .....	70
D.5 Item 1 test bed .....	71
D.6 Placement of Item 1 on simulated entryway .....	71
D.7 Item 2 .....	72
D.8 Item 2 in test bed .....	73
D.9 Item 3 .....	74
D.10 Item 4 .....	75
D.11 Items 3 and 4 in test bed .....	76
D.12 Posttest view of Item 1 .....	77
D.13 Posttest view of Item 2 .....	77
D.14 Posttest view of Item 3 .....	78
D.15 Posttest view of Item 4 .....	78

## LIST OF TABLES

<u>Table</u>	<u>Page</u>
2.1 Instrumentation Summary .....	11
2.2 Mannequin Accelerometer Summary .....	12
2.3 Backfill Average Moisture Content, Wet Density and Dry Density ...	12

## CONVERSION FACTORS, NON-SI TO SI (METRIC) UNITS OF MEASUREMENT

Non-SI units of measurement used in this report can be converted to SI (metric) units as follows:

<i>Multiply</i>	<i>By</i>	<i>To Obtain</i>
feet	0.3048	metres
gallons (US liquid)	3.785412	cubic decimetres
grains per foot	0.212595	grams per metre
g's (standard free fall)	9.806650	metres per second squared
horsepower (550 foot-pounds (force) per second)	745.6999	watts
inches	2.54	centimetres
kilotons (nuclear equivalent of TNT)	4.184	terajoules
megatons (nuclear equivalent of TNT)	4.184	petajoules
pounds (force) per square inch	6.894757	kilopascals
pounds (mass) per cubic foot	16.01846	kilograms per cubic metre

# Dynamic Test of a Corrugated Steel Keyworker Blast Shelter

## Chapter 1 INTRODUCTION

### 1.1 Background

At the initiation of this study, civil defense planning called for the evacuation of nonessential personnel to safe (low-risk) host areas when a nuclear attack is probable, requiring the construction of shelters to protect the key workers remaining in the risk areas. Both dedicated- and expedient-type shelters are planned. A dedicated shelter is a specially designed permanent blast shelter constructed near key workers. Presently a 100-man-capacity reinforced concrete shelter design is being considered. Reference 1 reports on static and dynamic tests of approximately 1/4-scale models of a reinforced concrete 100-man dedicated Keyworker blast shelter design. An expedient shelter is a shelter consisting of prefabricated components which can be stored near key sites until an international crisis develops. Required installation time should be less than 2 weeks. This report describes a verification test of an expedient shelter design.

The US Army Engineer Division, Huntsville (HND) has been tasked by the Federal Emergency Agency (FEMA) to investigate feasible shelter designs, construct and impale prototype shelters, and verify these designs by analysis and/or testing. HND contracted with the US Army Engineer Waterways Experiment Station (WES) to verify the design of an 18-man corrugated steel expedient shelter by dynamic testing. The shelter consisted of a 9-foot diameter<sup>1</sup> galvanized corrugated steel culvert section

approximately 30 feet long with end plates, a vertical entryway, and a mechanical air-moving system. Shelter design parameters required that the shelter survive a peak overpressure of 50 psi from a 1-MT nuclear weapon detonation. The structural design criteria and the levels of initial and residual radiation associated with the threat weapon dictated an earth-covered or buried structure. The shelter design required a depth of burial of 4 feet to meet these criteria.

### 1.2 Objectives

The main objective was to verify the corrugated steel shelter design for the threat weapon. This included verification of the structural design of the shelter and entryway, verification of the air-moving system components (generator, blower, and intake and exhaust systems), and verification of occupant survivability. A secondary objective was to evaluate alternate blast door closure designs for the shelter. The shelter should have a closure which not only provides adequate blast resistance, but also is economical, lightweight, and easily constructed.

### 1.3 Scope

The structure was provided to WES by HND and was tested dynamically using the High Explosive Simulation Technique (HEST). The HEST, as described in Reference 2, provides an economical way of simulating the peak overpressure and overpressure decay of a nuclear detonation. The HEST configuration for this test is described in detail in the following chapters of this report. To investigate occupant survivability, instrumented anthropomorphic mannequins

<sup>1</sup> A table of factors for converting non-SI to SI (metric) units of measurement is presented on page 5.

provided by the Lovelace Foundation were positioned in the standing, sitting, and supine positions. Their movement was documented using high-speed photography. The air-moving system's operation was tested pre- and posttest to investigate possible damage from the blast or ground shock.

Alternate blast closure designs were tested by WES in conjunction with the expedient shelter test program. The closures were designed and constructed by the Oak Ridge National Laboratory (ORNL) in Oak

Ridge, Tennessee. One closure, consisting of a stainless steel membrane, was included in test number 3 of the FEMA Yield Effects test series (Reference 3). Another closure design, having a 1/8-inch-thick carbon steel membrane, was tested during a calibration test used to design the charge cavity for the expedient shelter test. Three closures, including the original design for the shelter, were tested simultaneously with the expedient shelter in December 1984. Closure test specimens are described and the test results are detailed in Appendix D of this report.

## Chapter 2

# TEST DESCRIPTION

The 18-man, 9-foot-diameter steel blast shelter was tested dynamically on December 19, 1984 on Range 36 at Fort Polk, Louisiana. The shelter and test bed construction, instrumentation, material properties, and photographic coverage are described in the following sections.

### 2.1 Test Element Construction Details

The shelter (shown in Figure 2.1 without entryway) was furnished by HND. It was constructed by a private contractor in accordance with plans and specifications provided by HND. Detailed drawings of the shelter are presented in Appendix A.

The structure was fabricated from hot-dipped, galvanized, corrugated steel culverts. The main chamber of the shelter was 27 feet 6 inches long (inside dimension), 9 feet in diameter, and constructed from 10-gage corrugated steel. The entrance tunnel was constructed from 36-inch-diameter culvert sections. End plates were constructed from 1/2-inch-thick steel, and W 8 by 18 steel sections were used as stiffeners. All connections, splices, and joints were waterproofed.

As shown in Figures 2.2 and 2.3, the shelter was equipped with a fully operational generator, air exchange system, sleeping facilities, and a human waste disposal unit. A 250-gallon gasoline storage tank (visible in Figure 2.1) was provided for the generator. The generator exhaust system was installed separate from the air exchange system. Steel blind flanges were provided for blocking the air exchange and generator exhaust systems to prevent blast pressure from entering. The flanges should be in place during "button up" situations (immediately prior to and after a nuclear blast).

### 2.2 Test Configuration and Placement Details

The test configuration for the expedient shelter is shown in Figure 2.4. The test pit

was approximately 48 feet long, 36 feet wide, and 15 feet deep. A 2-foot layer of flume sand was placed in the test bed prior to placement of the shelter. The sand was placed in approximately 6-inch lifts and compacted with four passes of a 7-hp Dynapac Model CM-10 vibrator.

After the structure was placed in the test bed (Figure 2.5), the entryway shaft was bolted into position. Instrumentation gages were installed on the interior surface of the shelter, on the mannequins, and on the exterior surface of the shelter near the entryway.

Figure 2.6 shows the backfill partially complete. Two-inch-diameter steel pipe (visible in Figure 2.6) was used to support the airblast pressure gages and to protect the instrumentation cable during testing. The airblast pressure, soil-stress, and free-field acceleration gages were installed at their proper locations during the backfilling operation as discussed in Section 2.3 of this report.

The 48- by 36- by 3-foot charge cavity, supporting high explosive primacord, was constructed on the ground surface above the shelter as shown in Figure 2.7. The primacord strands visible in Figure 2.7 consisted of pentaerythritol tetranitrate (PETN) explosive made into a 50 gr/ft detonating cord. Sixty-eight strands of the primacord were placed at 8-3/8 inch on-center, running parallel to the direction of detonation indicated in Figure 2.4. The spacing of the primacord yielded a charge density of 0.0034 lb/ft.<sup>3</sup> The primacord strands were bundled into eleven groups containing 6 strands each and two groups containing 12 strands each. An 8-foot length of detonating cord was spliced to the end of each bundle. The 8-foot lengths of detonating cord were spliced together in one bundle, which enclosed the blasting cap that initiated the charge detonation.

The cavity consisted of a wooden frame covered with 3/4-inch-thick plywood as shown in Figures 2.7 and 2.8. A 4-foot-thick uncompacted sand overburden was placed over the charge cavity and extended approximately 11 feet beyond the edges of the cavity to minimize edge effects, as shown in Figure 2.9. The purpose of the overburden was to contain the blast in order to simulate the overpressure duration of a 1-MT nuclear weapon.

### 2.3 Instrumentation

The 60 channels of data collected during this test were recorded on two Sangamo Sabre III 32-channel FM magnetic tape recorders located in an instrumentation trailer approximately 1,000 feet from the test site. The data were recorded at a tape speed of 120 in/s and later digitized at a rate of 200 kHz. A zero-time channel was used to establish a common time reference for the recorded data. Instrumentation for the test included airblast pressure, strain, soil stress, acceleration, and deflection measurements. Table 2.1 summarizes the gage types and ranges. The locations given in Table 2.1 correspond to those shown in Figure 2.10.

Ten Kulite Model HKS-375 airblast pressure gages (BP) were used to measure the overpressure-time history. These gages were positioned at ground level directly beneath the charge cavity. The airblast gage mounts included a baffle plate to prevent destruction of the gage by high pressure spikes. One Kulite Model XT airblast pressure gage (AB) was mounted inside the shelter to monitor any changes in chamber pressure.

Eleven single-axis, metal-film, 0.25-inch-long, 350-ohm, temperature-compensated strain (E) gages were located at midlength of the shelter on the interior surface. Four additional strain gages were installed on the exterior surface of the shelter near the entrance tunnel. Figure 2.11 shows three of the tape-covered gages near the entryway.

Seven free-field soil-stress (SE) gages

were located at depths ranging from 1 to 13 feet at the locations shown in Figure 2.10. Six additional SE gages were positioned tangent to the shelter's exterior surface at midlength of the main chamber.

Accelerations of the structure were measured with Endevco 2262 accelerometers (A). Seven gages were installed to measure accelerations perpendicular to the interior surface at the locations shown in Figure 2.10. Two accelerometers (A8 and A9) were located on the plywood floor inside the structure. One accelerometer (AF-1) was placed in the backfill to measure free-field acceleration.

Triaxial accelerations of the three mannequins were measured with Endevco 2262 accelerometers (AD). The mannequins were positioned as shown in Figure 2.12. The accelerometers were installed in the chest cavity of the mannequin in the supine position, and in the lower back area of the one in the sitting position. Accelerometers were mounted on the left ankle of the standing mannequin. Table 2.2 summarizes the orientation of the accelerometers.

Two Celesco PT-101-10-A-7559 position/displacement transducers were mounted inside the structure to monitor changes in the diameter of the main chamber near its midlength. The transducers measured the changes in diameter by means of a potentiometer which detected the extension and retraction of a cable attached to a spring. One transducer measured vertical deflections, and one measured horizontal deflections.

### 2.4 High-Speed Photography

A Tho-Tec IV 16-mm high-speed rotating prism camera was mounted inside the shelter to monitor the motions of the mannequins. The field of view for the camera was that shown in Figure 2.12. A frame rate of approximately 10,000 frames per second was used. Four 2,000-watt cinematographic lights illuminated the shelter during the test. A flash bulb

connected to the firing line marked the blast zero time.

### **2.5 Backfill Material Properties**

The sand backfill was obtained from a commercial supplier in the Fort Polk, Louisiana, area. The backfill was a flume sand classified as a poorly graded sand (SP) by the Unified Soil Classification System (Reference 4).

The sand was placed in 6-inch lifts and

compacted with four passes of a 7-hp Dynapac Model CM-10 gasoline-powered vibrator. Water content and density tests were conducted after each layer of backfill was placed. Table 2.3 presents average moisture content, wet density, and dry density for the backfill. The uncompacted sand overburden, which was identical to the backfill sand, was placed to a depth of 4 feet over the charge cavity.

**Table 2.1. Instrumentation Summary.**

<i>Gage</i>	<i>Location</i>	<i>Range</i>	<i>Manufacturer</i>	<i>Model</i>
Airblast pressure	BP-1 through BP-10	500 psi	Kulite	HKS-375
Strain	AB-1	15 psi		XT
	E-1 E-1A E-2 through E-5 E-5A E-6 through E-13	10,000 $\mu$ in/in	Micro-measurements	EA-06-250-BF-350-W
Soil stress	SE-1 through SE-8 SE-8a SE-9 SE-10 SE-11 SE-11A	200 psi	Kulite	LQV-080-8UH
Acceleration (structure)	A-1 through A-9	200 g's	Endevco	2262
Acceleration (free-field)	AF-1	200 g's	Endevco	2262
Acceleration (mannequin)	ADX-1 ADY-1 ADZ-1 ADX-2 ADY-2 ADZ-2 ADX-3 ADY-3 ADZ-3	100 g's	Endevco	2262
Displacement	D1 D2	10 inches	Celesco	PT-101-10-A-7559

**Table 2.2. Mannequin Accelerometer Summary.**

<i>Gage</i>	<i>Mannequin</i>	<i>Gage Orientation</i>
ADX-1 ADY-1 ADZ-1	Supine	Horizontal (parallel to structure's longitudinal axis) Horizontal (perpendicular to structure's longitudinal axis) Vertical
ADX-2 ADY-2 ADZ-2	Sitting	Horizontal (parallel to structure's longitudinal axis) Horizontal (perpendicular to structure's longitudinal axis) Vertical
ADX-3 ADY-3 ADZ-3	Standing	Horizontal (perpendicular to structure's longitudinal axis) Horizontal (parallel to structure's longitudinal axis) Vertical

**Table 2.3. Backfill Average Moisture Content, Wet Density and Dry Density.**

<i>Depth, feet</i>	<i>Average Moisture Content, percent</i>	<i>Average Wet Density, lb/ft<sup>3</sup></i>	<i>Average Dry Density, lb/ft<sup>3</sup></i>
Ground surface	6.2	110.9	104.0
1	6.8	109.2	101.8
2	6.3	110.2	103.3
3	6.3	109.5	102.6
4	7.2	111.0	103.0
5	5.8	111.5	105.0
6	4.4	110.6	105.7
7	6.7	109.5	102.2
8	7.8	110.2	101.6
9	5.7	108.6	102.4
10	5.5	110.7	104.6
11	5.0	108.5	103.1
12	5.1	109.4	103.8
13	6.4	109.1	102.1
14	6.4	107.1	100.2



Figure 2.1. Expedient shelter without entryway at test site.



Figure 2.2. View of shelter's facilities.



Figure 2.3. Close-up of generator area.

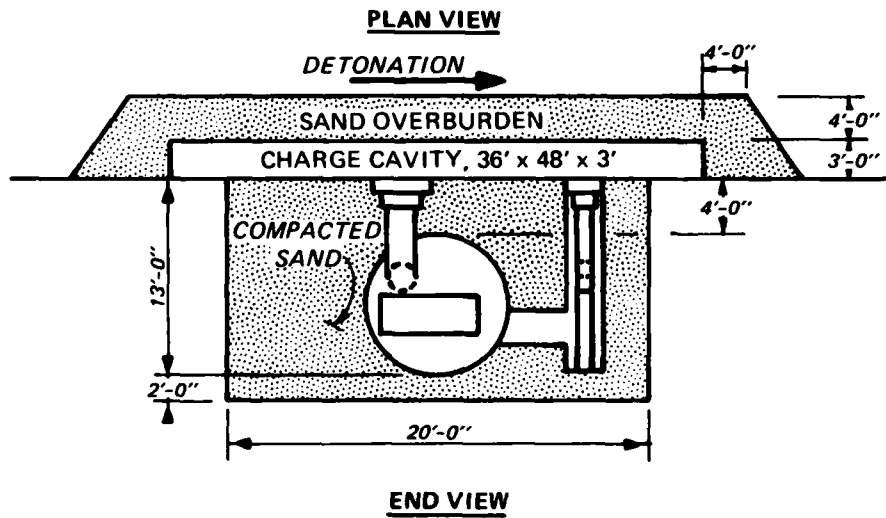
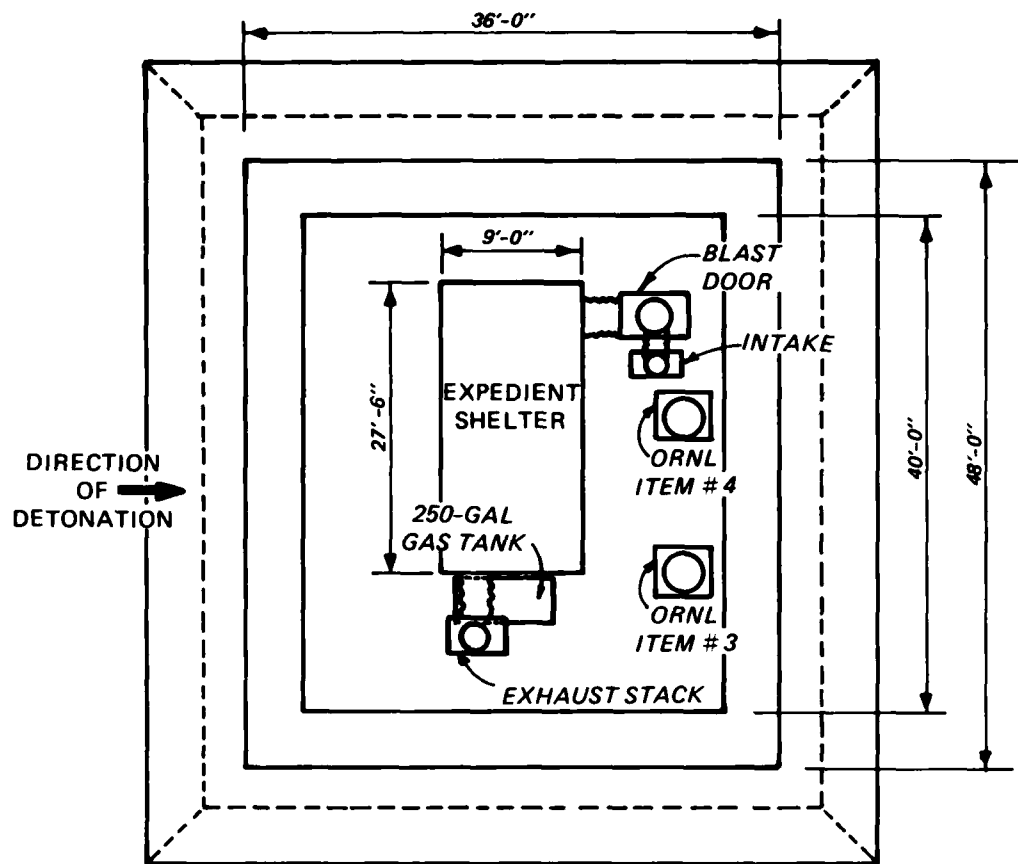
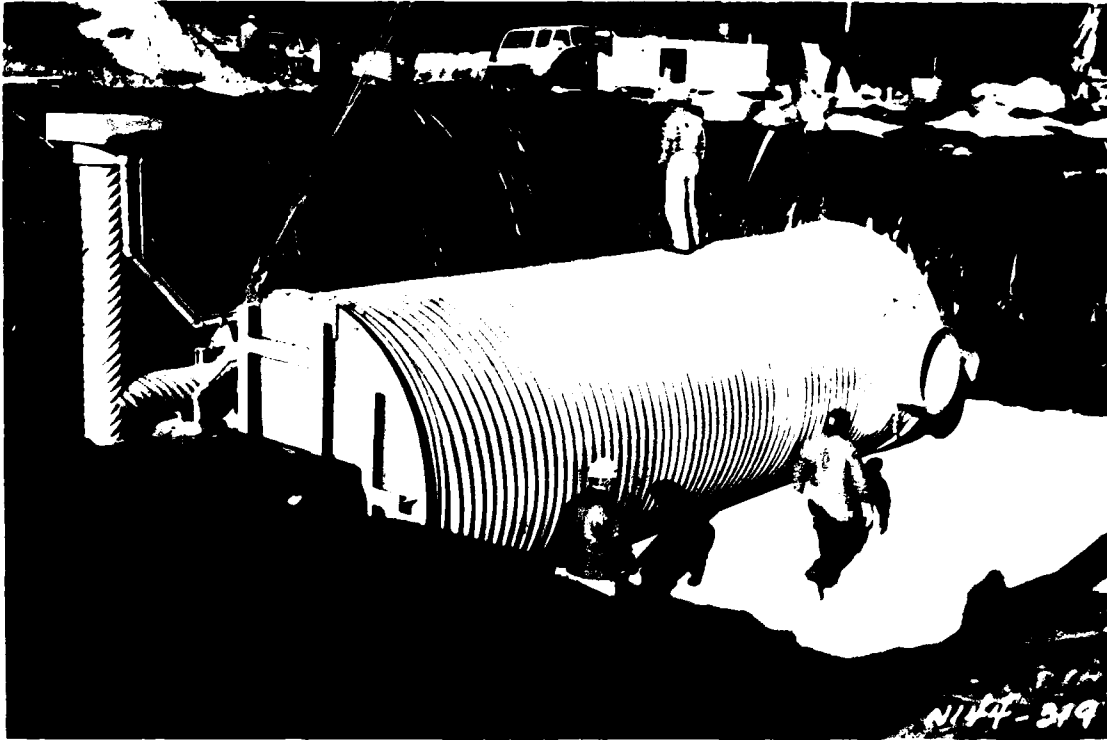

Figure 2.4. Test configuration.



**Figure 2.5. Placement of structure in test bed.**



**Figure 2.6. Sand backfill.**



Figure 2.7. Charge cavity construction.



Figure 2.8. Charge cavity.



**Figure 2.9. Completed overburden placement.**

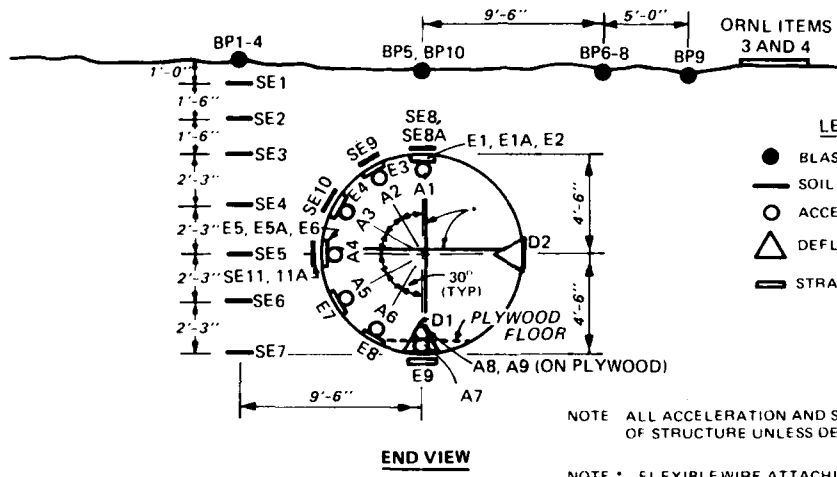
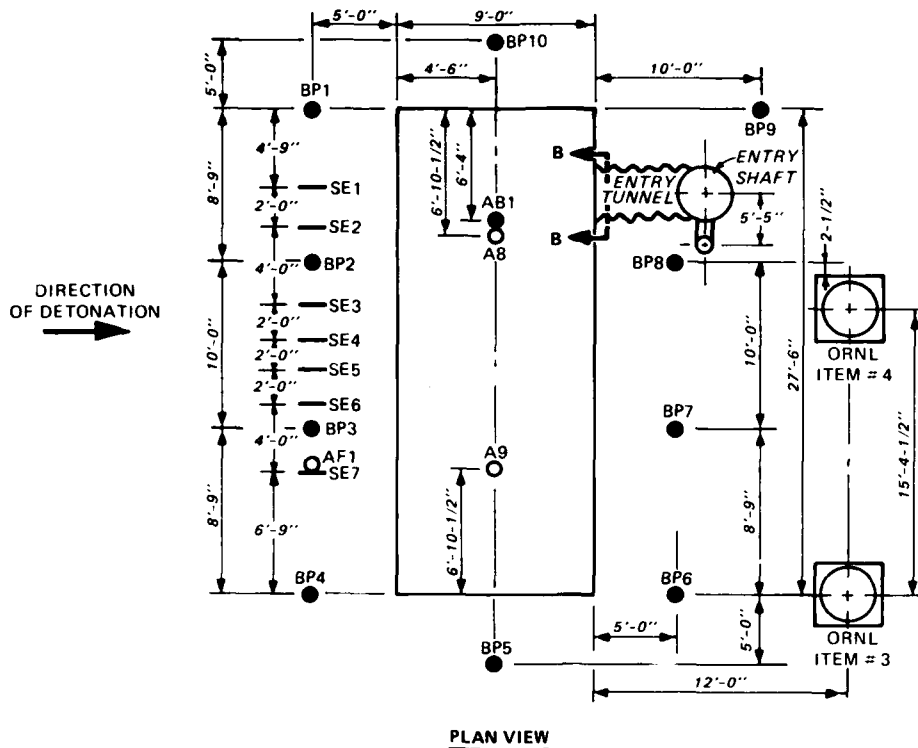

NOTE ALL ACCELERATION AND STRAIN AT MID-LENGTH OF STRUCTURE UNLESS DENOTED

NOTE \* FLEXIBLE WIRE ATTACHING DEFLECTION GAGE CABLE TO OPPOSITE WALLS

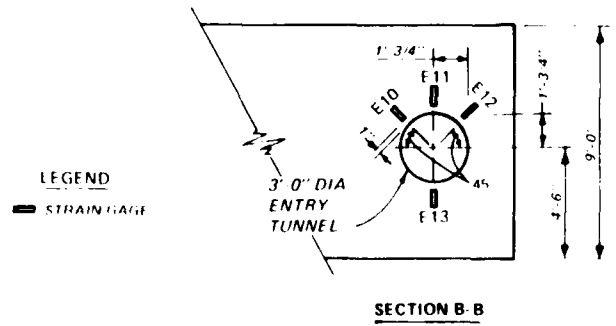

Figure 2.10. Instrumentation locations.



Figure 2.11. Strain gages over entryway.



Figure 2.12. Instrumented mannequins.

## Chapter 3

### TEST RESULTS

#### 3.1 Damage

Figure 3.1 shows the displacement of the soil overburden resulting from the explosion. Figure 3.2 is a posttest view of the test bed prior to removal of the overburden. Most of the sand overburden and charge cavity debris settled over the shelter, obstructing immediate access. After removal of the overburden and debris the blast closure was found intact and operable.

Posttest observations revealed that only minor structural damage occurred. Permanent diameter changes of approximately 0.6 to 0.8 inch were measured. Rigid-body displacements were limited to less than 0.5 inch. The entryway, closure, and entryway-shelter connections incurred no damage, and the end plates of the main chamber were undeformed. Also, the mechanical air-moving system and generator were functional posttest.

Figure 3.3 is an interior view of the shelter, showing the pretest and posttest positions of the mannequins. The pretest view

(Figure 3.3a) was taken from a frame of the high-speed movie. Figure 3.3 indicates that posttest mannequin positions were similar to pretest positions. The movements of the mannequins are discussed in more detail in Section 4.2.

#### 3.2 Recovered Data

The recovered data are presented in Appendix B. A summary of the data is presented in this section, and a more detailed evaluation is presented in Chapter 4. The data are referenced to a common zero time and are displayed with time in milliseconds as the abscissa. In general, data recovery for airblast pressure, strain, soil stress, and acceleration measurements was good. Only the data from airblast pressure gage BP-8 were not recovered. Because of spikes on the data plots which are not real data, data plots in the appendix for gages A-7 and ADX-2 were truncated. Also the first 60 ms of data from gage ADY-3 was truncated due to a spike.



Figure 3.1. Displacement of overburden during test.

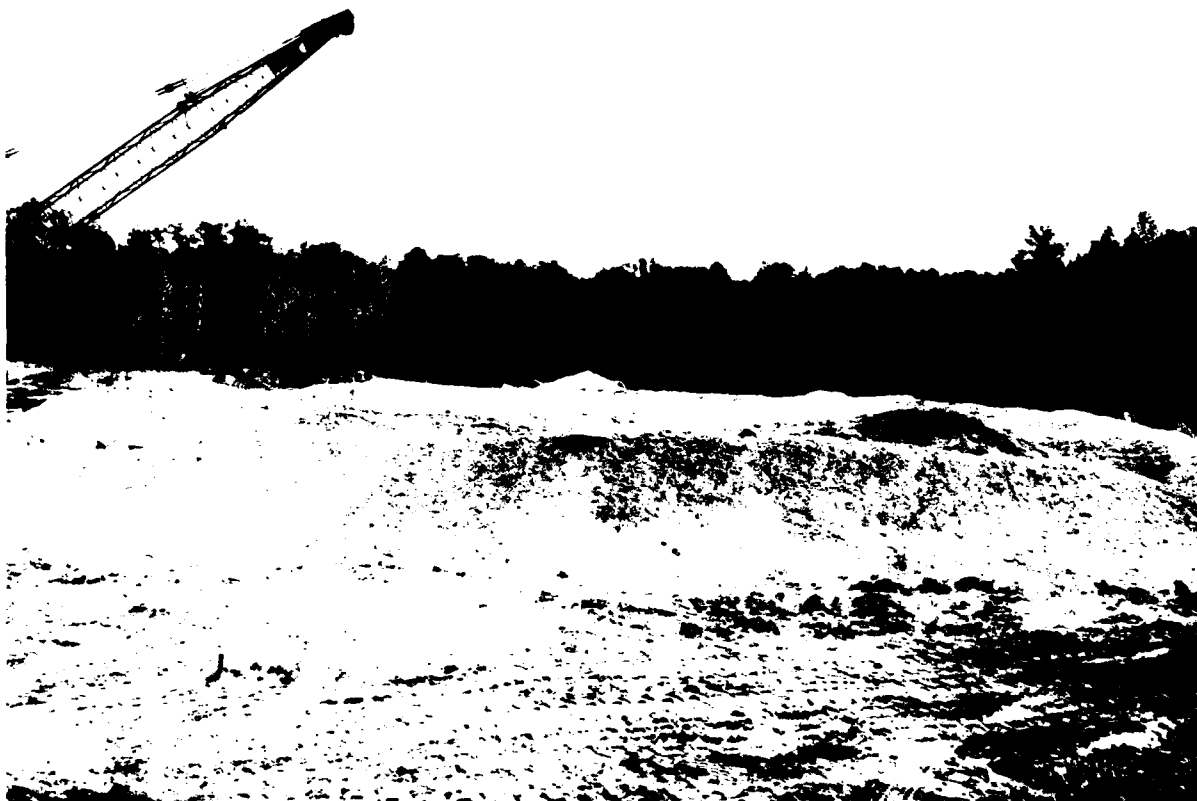

Figure 3.2. Overburden and charge cavity debris (posttest).



a. Pretest positions.



b. Posttest positions.

Figure 3.3. Mannequins inside shelter.

## Chapter 4

# DATA ANALYSIS

### 4.1 Nuclear Weapon Simulations

Estimates of the surface-burst nuclear yield and overpressure which best correspond to the airblast data records are required to define the loading function. The weapon simulation was determined by choosing the best fit, in a least-squares sense, of 45 ms of the airblast data to a 1-MT nuclear weapon pressure-time history as defined by Speicher and Brode (Reference 5). The procedure used to select the best fit is defined in some detail in Reference 6. The weapon simulations for each recovered airblast data record are tabulated below:

<i>Gage</i>	<i>Weapon MT</i>	<i>Overpressure, psi</i>
BP-1	1	57
BP-2	1	52
BP-3	1	58
BP-4	1	54
BP-5	1	53
BP-6	1	55
BP-7	1	58
BP-9	1	57
BP-10	1	54

The pressure and impulse data for each recovered airblast pressure record with the best-fit nuclear pressure and corresponding impulse time histories superimposed are included in Appendix C.

### 4.2 High-Speed Movie Data Reduction

A high-speed movie of the interior of the shelter during the test was recovered and analyzed. Displacement coordinates were determined from the movie using a Vanguard Model M-16C Motion Analyzer. Displacements of specified points on each of the three mannequins were measured at 5-ms intervals. Plots of displacement versus time for the three mannequins are presented in Figures 4.1-4.4. Measurements were taken

at a point on the chest of the standing mannequin and at the tip of the nose of the sitting mannequin. The movement of a point on the foot of the lying mannequin was measured.

The maximum displacement of the standing mannequin was approximately 1.1 inches downward, and the maximum upward displacement of the mannequin was approximately 0.6 inch from the original position. The final position of the mannequin was approximately 1.1 inches downward from the original position as the mannequin slumped and leaned against a bunk.

The sitting mannequin slumped forward during the test but did not fall from the edge of the bunk. The head of the mannequin initially moved backward approximately 1.4 inches, and then forward to a final position approximately 7.6 inches (measured horizontally) from the original position. The maximum upward displacement of the mannequin was approximately 1.3 inches, and the maximum downward displacement was approximately 1.8 inches. The final vertical position of the mannequin (measured at the tip of the nose) was approximately 1.5 inches below the original setting.

Only the feet of the mannequin in the supine position were visible in the high-speed movie. The maximum downward displacement of the mannequin was approximately 1.0 inch, and the maximum upward displacement was approximately 4.1 inches from the original position. The movement of the mannequin ceased at approximately 125 ms after detonation of the explosives as its feet rested on the bunk.

### 4.3 In-Structure Shock

In-structure shock is typically represented in terms of shock spectra. Shock

spectra are plots of the maximum responses, usually of relative displacement, pseudo-velocity, and/or absolute acceleration of all possible linear oscillators with a specified amount of damping to a given input base acceleration-time history. Predictions of shock spectra for vertical effects from a 1-MT surface burst were made by Applied Research Associates, Inc. (Reference 7). The predicted shock spectra at the 50-psi peak overpressure level are presented in Figure 4.5.

Vertical shock spectra were generated from acceleration data recovered in the dynamic test using a computer code developed at WES. The experimentally determined shock spectra were calculated using a damping of 5 percent of critical, and smoothed versions are shown in Figures 4.6 and 4.7 for accelerometers A6 and A9, respectively. As shown in Figure 2.10, accelerometer A6 was located on the steel structure and A9 was located on the plywood floor of the shelter. Comparison of Figures 4.5 and 4.6 shows that maximum values of velocity and displacement of the structure are less than predicted, but that the maximum value of acceleration (38 g's) is greater than the predicted 29 g's. Comparison of Figures 4.5 and 4.7 shows that maximum values of velocity (95 in/s) and acceleration (80 g's) of the plywood floor are higher than the predicted values (80 in/s and 29 g's, respectively), and that the maximum value of displacement (0.8 inch) is lower than the predicted 4.2 inches. Note that the simulated peak overpressure of 55 psi is slightly greater than the 50-psi threat peak overpressure.

At frequencies greater than about 100 Hz, the experimentally determined shock spectra may not be representative of shock spectra due to an actual nuclear detonation because of oscillations in the surface airblast loading, characteristic of the HEST charge cavity. The maximum acceleration value of 80 g's shown in Figure 4.7 reflects a shift

from a calculated value of about 120 g's, resulting in a maximum plywood floor acceleration twice that of the structure. It is believed that the calculated value was affected by the oscillations in the HEST airblast loading that would not be present in overpressures generated by actual nuclear weapons.

**4.3.1 Occupant survivability.** References 8 and 9 discuss human shock tolerance. The effects of shock on personnel inside the structure depend on the magnitude, duration, frequency, and direction of the motion. Also, the position of the man at the time of shock influences its effect. References 8 and 9 conclude that a standing man will receive compressive injuries in the body-supporting bones if the upward floor acceleration exceeds 20 g's during a long-duration loading. The injury threshold increases as the duration of the load decreases. Reference 9 recommends using a maximum design acceleration of 10 g's at frequencies at or below man's resonant frequency in the standing position (10 Hz). The experimentally determined shock spectra show that, at overpressures slightly higher than the design overpressure, no injury will occur. Since human shock tolerance is higher in the seated and supine positions than in the standing position, the probability of injury decreases.

Impact injuries occur at much lower accelerations than compressive bone fractures. Generally, impact injuries may occur at accelerations of 0.5 to 1 g for an unrestrained man in the standing or seated positions. These injuries are the result of falling and hitting the floor or other objects. Impact injuries may be reduced by padding or restraining to prevent movement. The high-speed photographic analysis presented in section 4.2 indicates that impact injuries are not probable, although vertical accelerations of 3, 6, and 9 g's were measured on the lying, standing, and sitting mannequins, respectively.

**4.3.2 Mechanical equipment survivability.** The vertical shock spectra in Figures 4.6 and 4.7 can be used to determine whether shock isolation is needed for a given piece of equipment, provided fragility curves for the equipment are known. Alternatively, these shock spectra can be used to write shock resistance specifications that equipment must be able to withstand. Figure 4.8

compares the experimentally determined shock spectra with safe response spectra for typical floor-mounted equipment from Reference 10. Figure 4.8 shows that motor generators and communication equipment should be shock-isolated to survive. The generator inside the tested shelter was supported on vibration mounts on a mounting skid and incurred no damage.

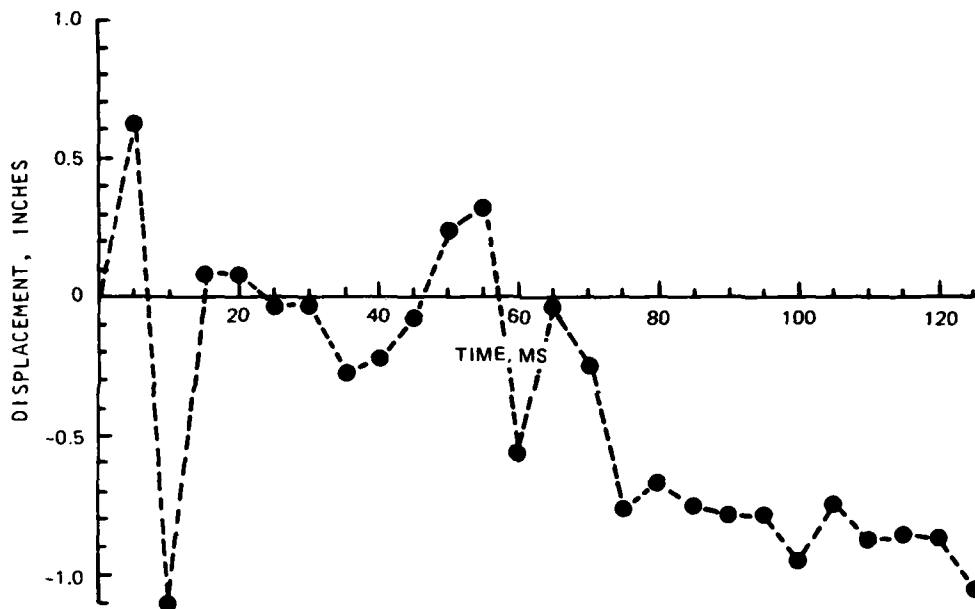
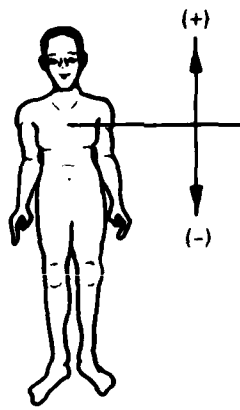

Figure 4.1. Displacement versus time plot for mannequin in standing position.

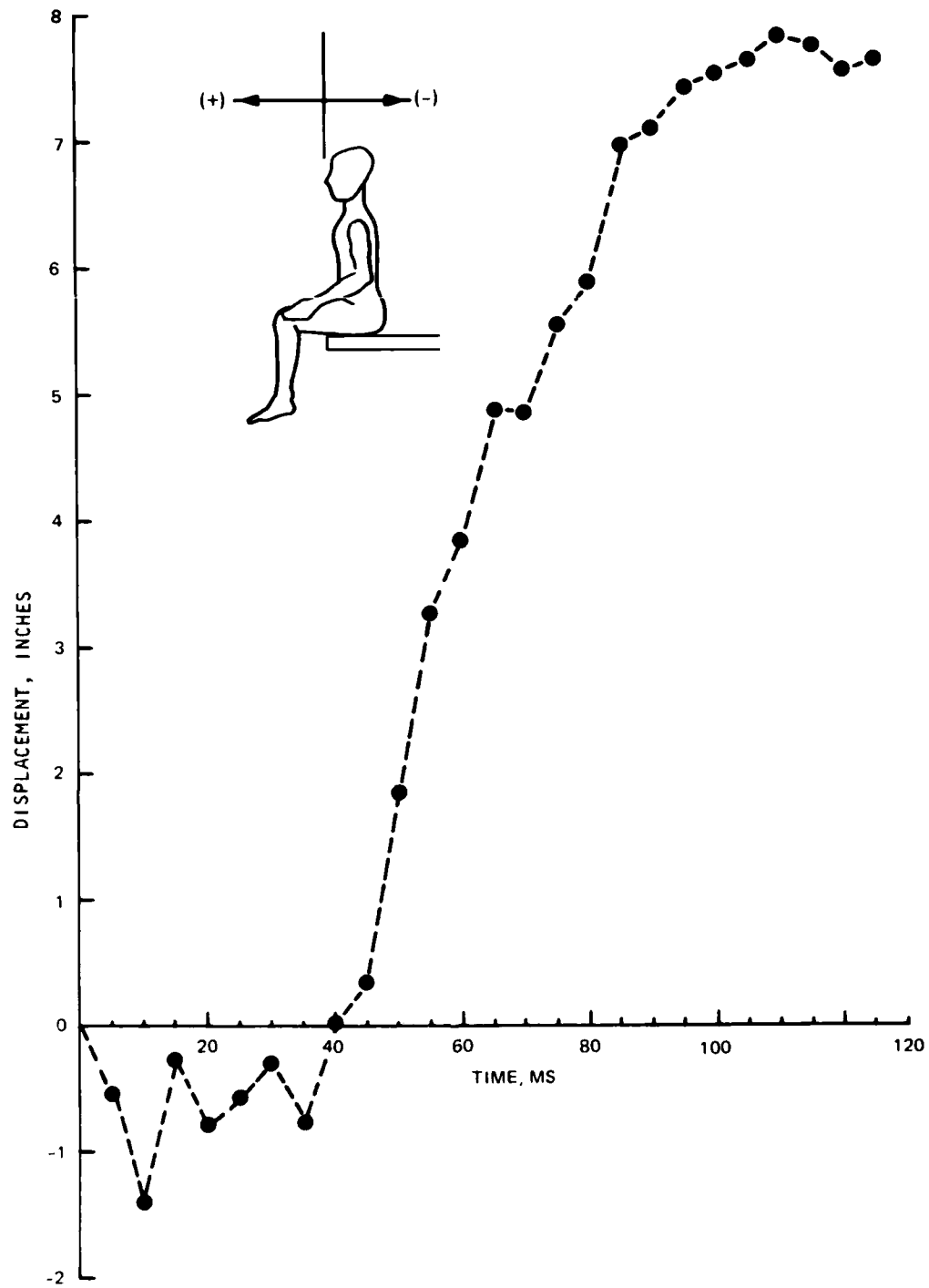

Figure 4.2. Horizontal displacement versus time plot for mannequin in sitting position.

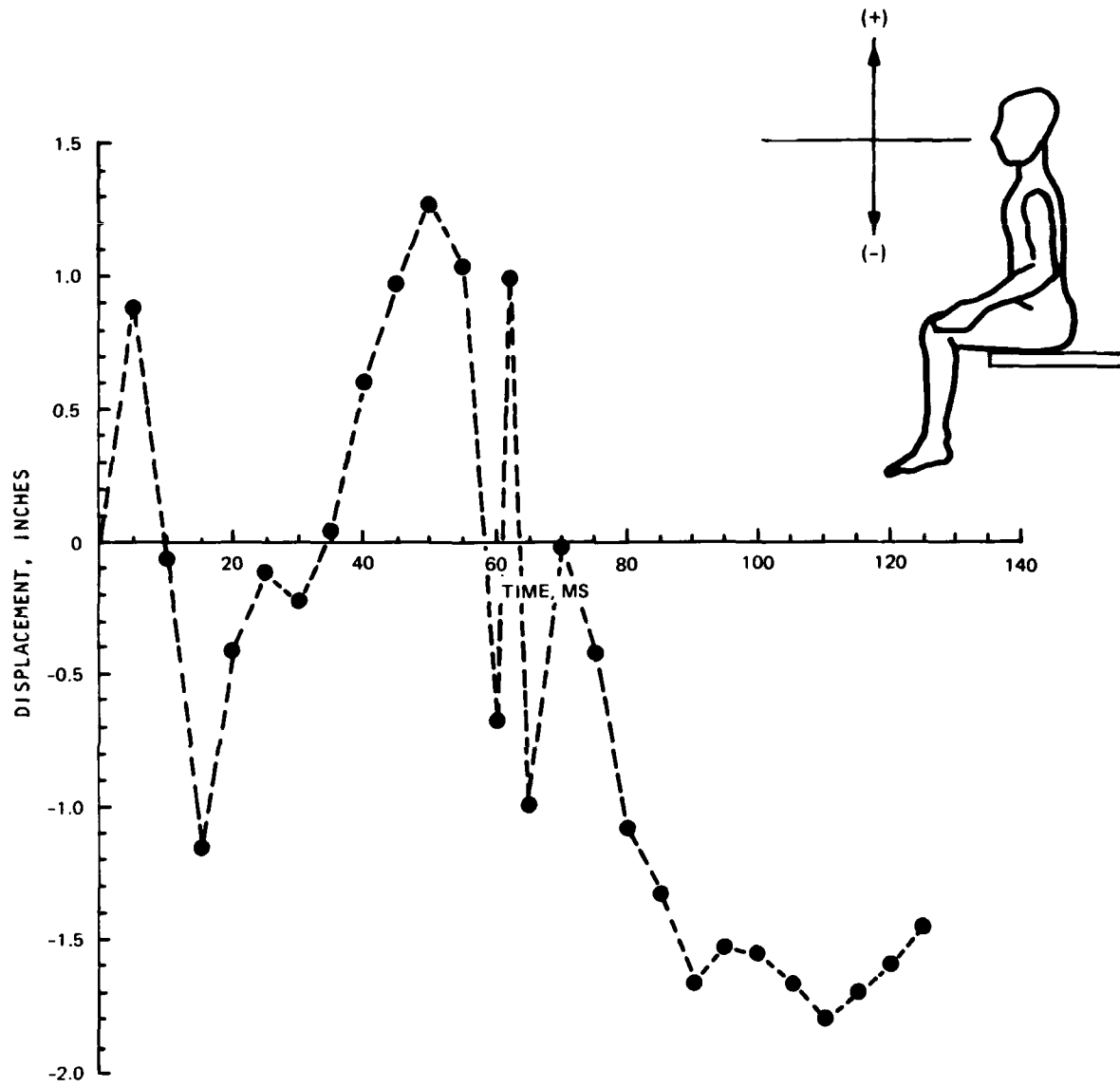

Figure 4.3. Vertical displacement versus time plot for mannequin in sitting position.

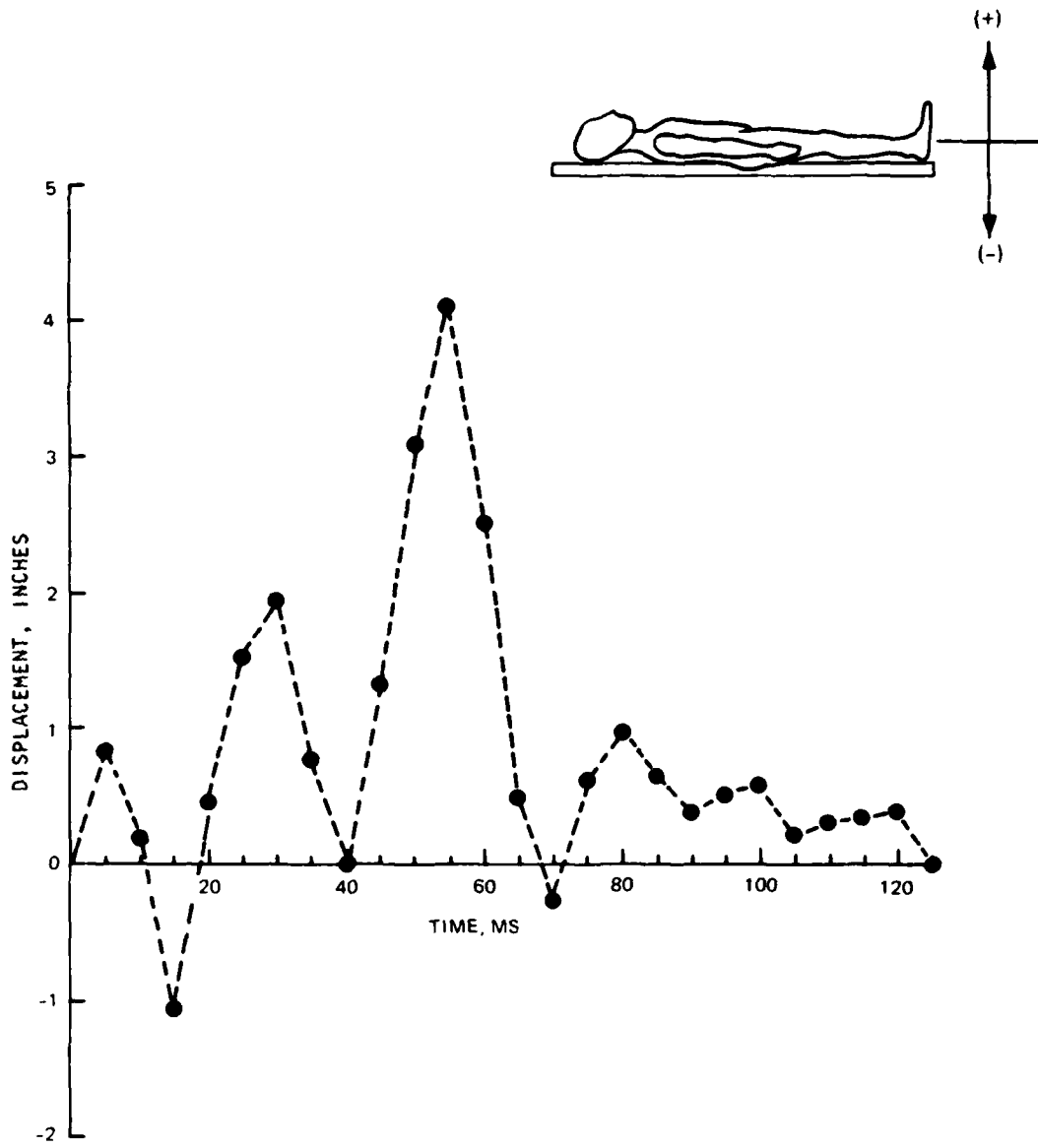

Figure 4.4. Displacement versus time plot for mannequin in supine position.

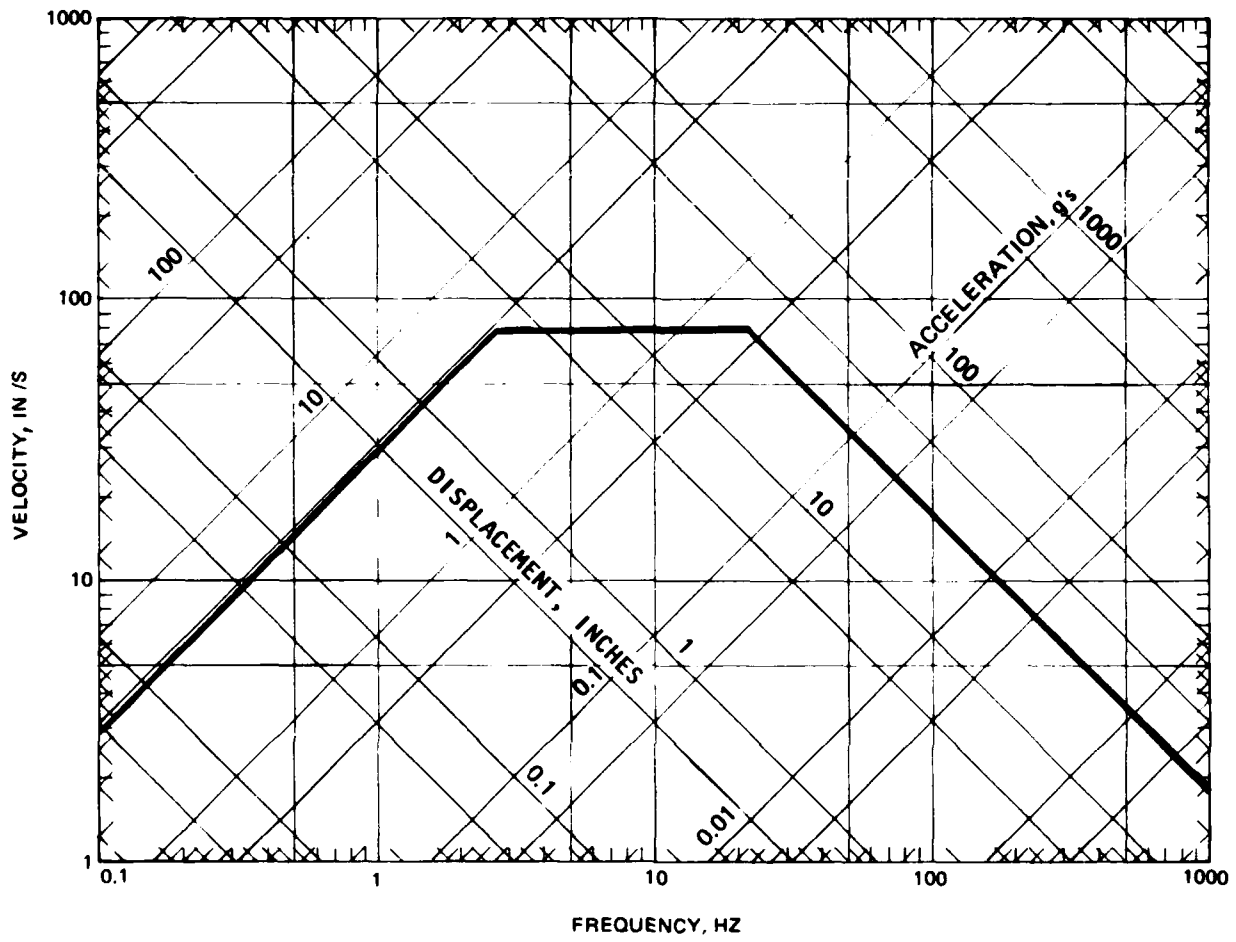

Figure 4.5. Predicted shock spectra.

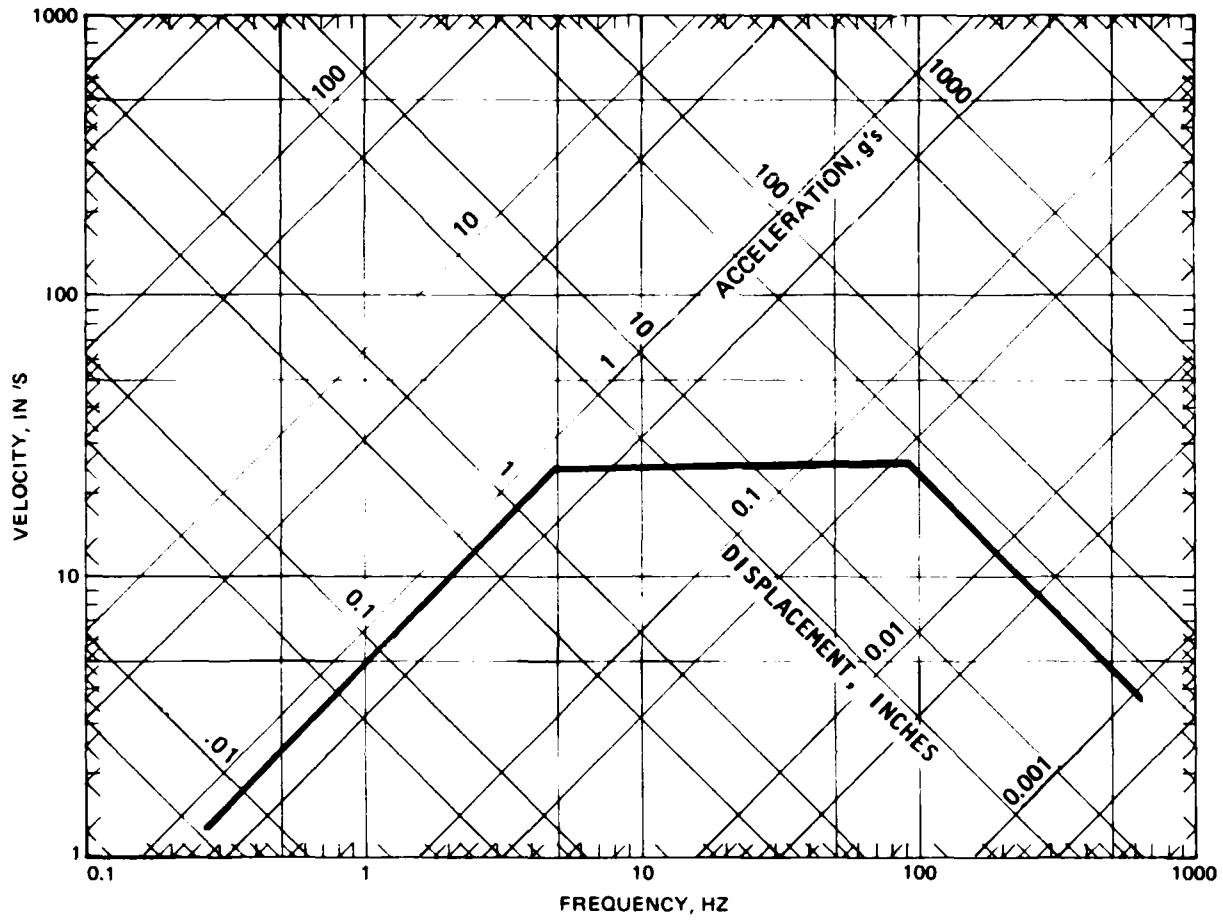

Figure 4.6. Vertical shock spectra from accelerometer A6.

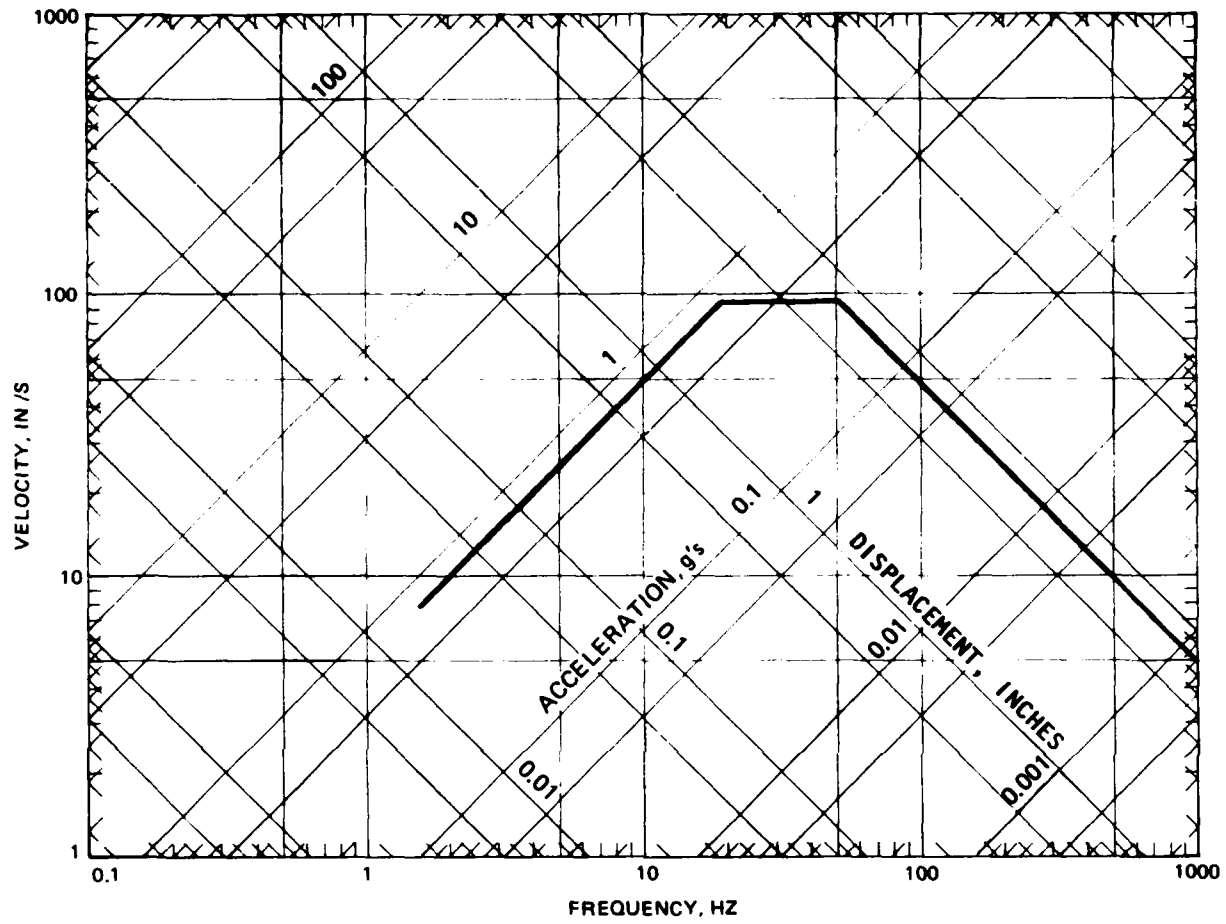

Figure 4.7. Vertical shock spectra from accelerometer A9.

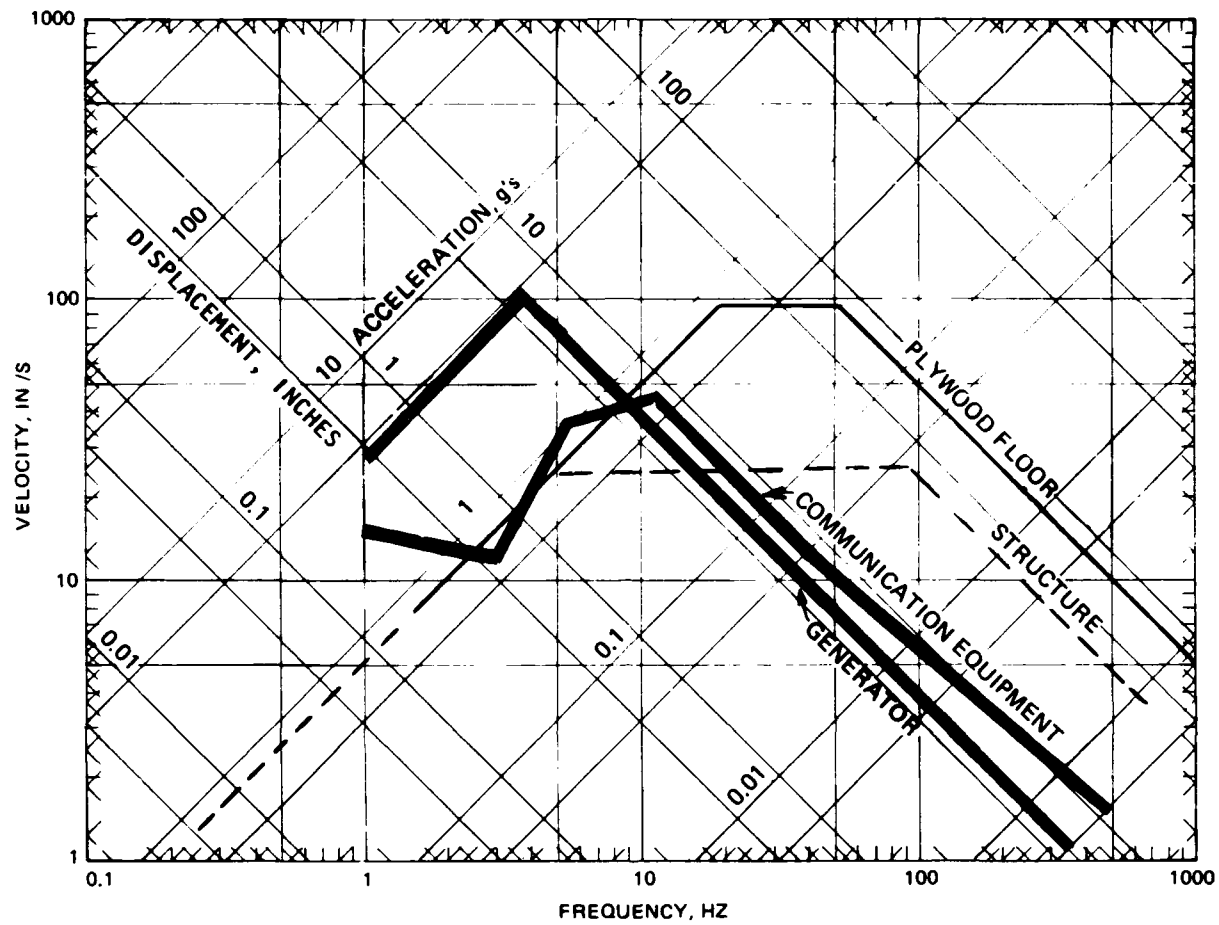

Figure 4.8. Comparison of experimental shock spectra with response spectra for typical floor-mounted equipment.

## Chapter 5

# CONCLUSIONS AND RECOMMENDATIONS

### 5.1 Conclusions

A HEST test simulating a 1-MT nuclear surface burst near the 50-psi peak over-pressure level on a full-scale structure was successfully conducted. The test showed that the prefabricated corrugated steel shelter can withstand the simulated nuclear weapon threat with only minor damage. Based on results of the full-scale dynamic test, in-structure shock in the 18-man shelter is within acceptable limits for occupants. No injury to personnel inside the shelter during a real crisis is expected. Typical floor-mounted shelter equipment (generators and communication devices) should be isolated on pads to ensure survivability.

### 5.2 Recommendations

The test indicated that several components, for example, end walls, blast closure, closure supports, and blast valve,

could be redesigned to be less massive. The redesigned structure should be both less costly and lighter in weight for easier transport and installation when needed. The tested shelter discussed in this report could be modified and retested since the damage was so light.

Recommended modifications include: (1) replacing the heavy reinforced ends of the shelter body with thin plate closures, (2) replacing the blast door with a less expensive "yielding membrane" design, (3) replacing the 5- by 5-foot door frame with a smaller frame constructed from a standard size 4- by 4-foot steel plate, and (4) employing simple pressure-actuated blast valves in air intake and exhaust shafts. These recommendations were also evaluated and recommended by the Oak Ridge National Laboratory.

## REFERENCES

1. T. B. Slawson and others; "Structural Element Tests in Support of the Keyworker Blast Shelter Program"; Technical Report SL-85-8, October 1985; US Army Engineer Waterways Experiment Station, Vicksburg, Miss.
2. H. W. Wampler, G. G. Leigh, and M. E. Furbee; "A Status and Capability Report on Nuclear Airblast Simulation Using HEST"; Proceedings, Nuclear Blast and Shock Simulation Symposium, Volume 1, November 1978; General Electric—TEMPO, Santa Barbara, Calif.
3. T. R. Slawson, S. B. Garner, and S. C. Woodson; "Yield Effects on the Response of a Buried Blast Shelter" (in preparation); US Army Engineer Waterways Experiment Station, Vicksburg, Miss.
4. US Department of Defense; "Unified Soil Classification System for Roads, Airfields, Embankments, and Foundations"; Military Standard MIL-STD-619B, 1968; Washington, DC.
5. S. J. Speicher and H. L. Brode; "Airblast Overpressure Analytic Expression for Burst Height, Range, and Time Over an Ideal Surface"; PSR Note 385, November 1981 (with updates through November 1982); Pacific-Sierra Research Corporation, Santa Monica, Calif.
6. P. F. Mlakar and R. E. Walker; "Statistical Estimation of Simulated Yield and Overpressure"; The Shock and Vibration Bulletin, Bulletin 50, Part 2, September 1980; The Shock and Vibration Information Center, Naval Research Laboratory, Washington, DC.
7. "Multiple Burst Damage Patterns and Ground Shock Analysis of Effects on Buried Structures"; Progress Report No. 2 (Draft, April 1982); Applied Research Associates, Inc., Alexandria, Va.
8. "Personnel and C-E Equipment Shock Tolerance"; Summary Report, 1977; Boeing Aerospace Co., Seattle, Wash.
9. R. E. Crawford and others; "The Air Force Design Manual for Design and Analysis of Hardened Structures"; 1974; Air Force Weapons Laboratory, Kirtland Air Force Base, N. Mex.
10. Headquarters, Department of the Army; "Fundamentals of Protective Design for Conventional Weapons"; Technical Manual TM 5-855-1, 1965 (revision in preparation); Washington, DC.

**Appendix A**  
**CONSTRUCTION DETAILS**



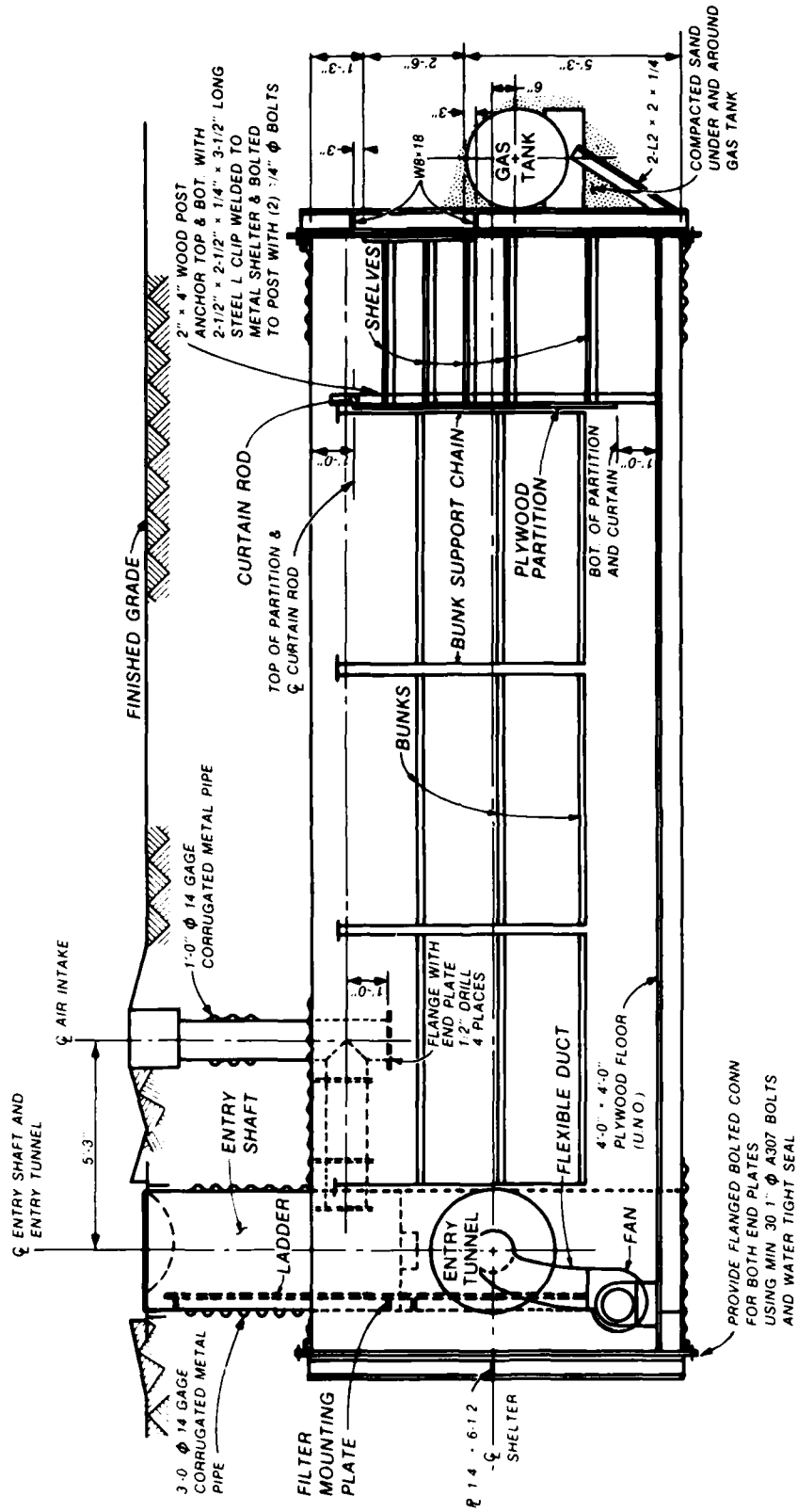

**SECTION A-A**

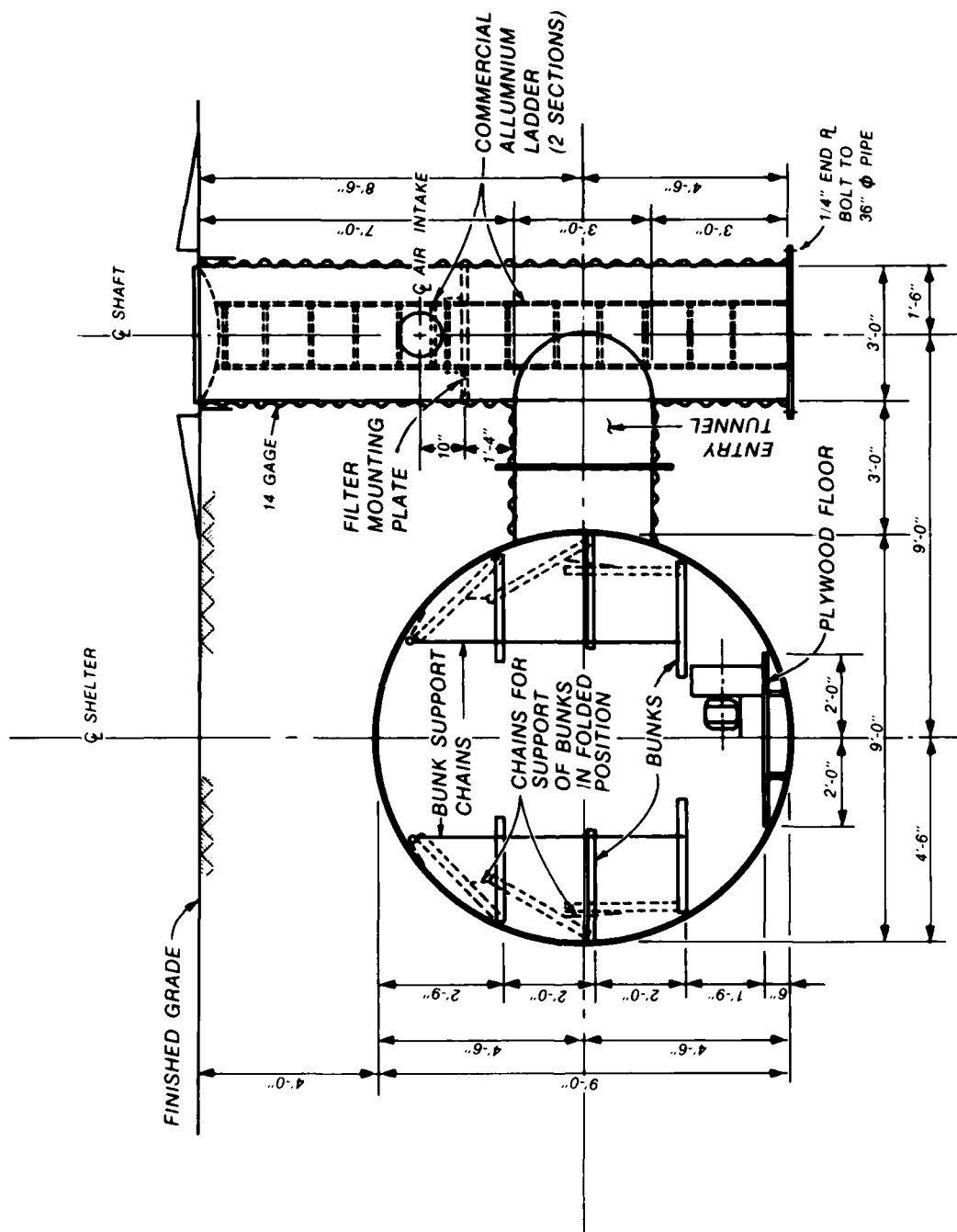

**SECTION B-B**



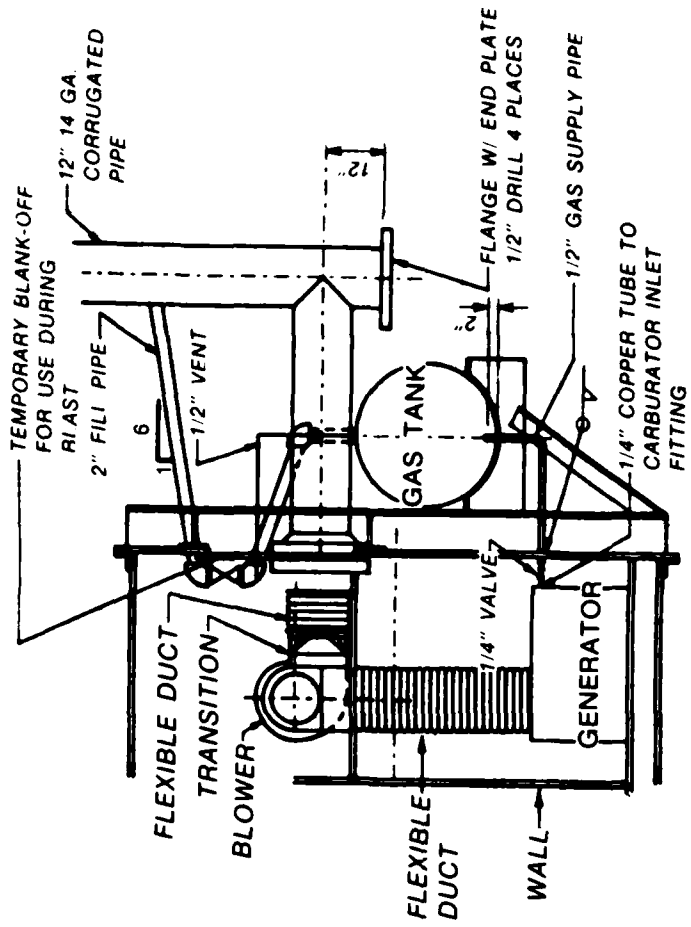

**SECTION D-D**

**Appendix B**  
**TEST DATA**

FEMA EXP SHELTER

D-1

50000. HZ CAL= 7.150  
LP4/0 70% CUTOFF= 2250. HZ

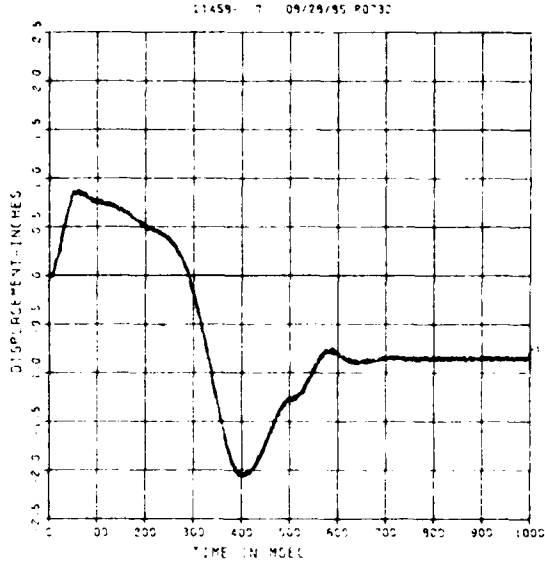

FEMA EXP SHELTER

D-2

50000. HZ CAL= 3.090  
LP4/0 70% CUTOFF= 2250. HZ

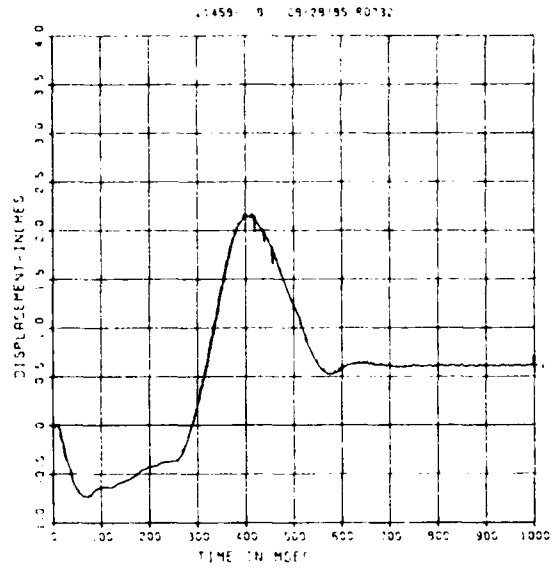

FEMA EXP SHELTER

SE-1

200000. HZ CAL= 127.8  
LP2/0 70% CUTOFF= 18000. HZ

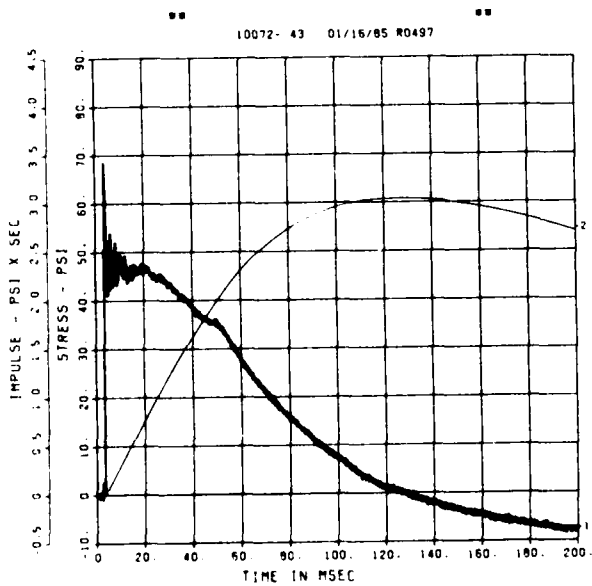

FEMA EXP SHELTER

SE-2

200000. HZ CAL= 125.8  
LP2/0 70% CUTOFF= 18000. HZ

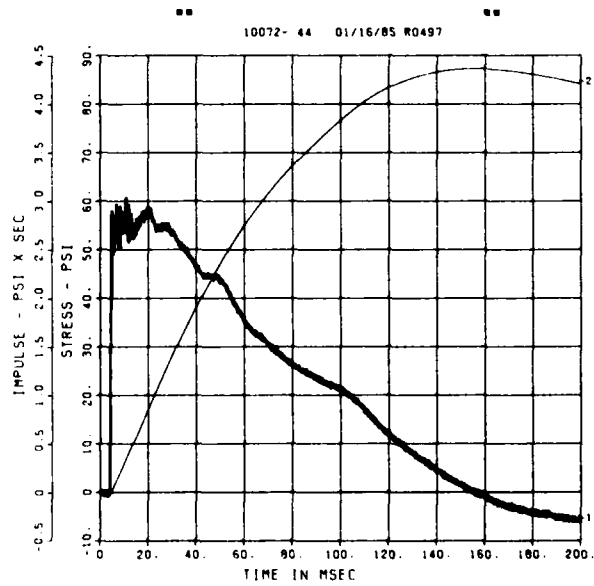

FEMA EXP SHELTER  
SE-3  
200000. HZ CAL= 81.90  
LP2/0 70% CUTOFF= 18000. HZ

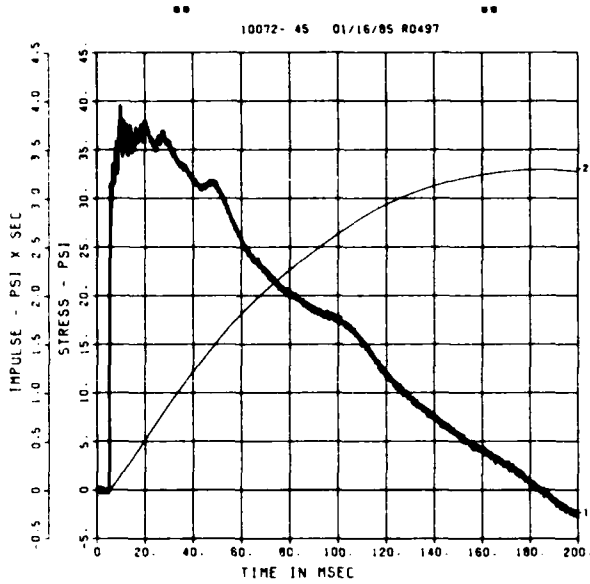

FEMA EXP SHELTER  
SE-4  
200000. HZ CAL= 56.70  
LP2/0 70% CUTOFF= 18000. HZ

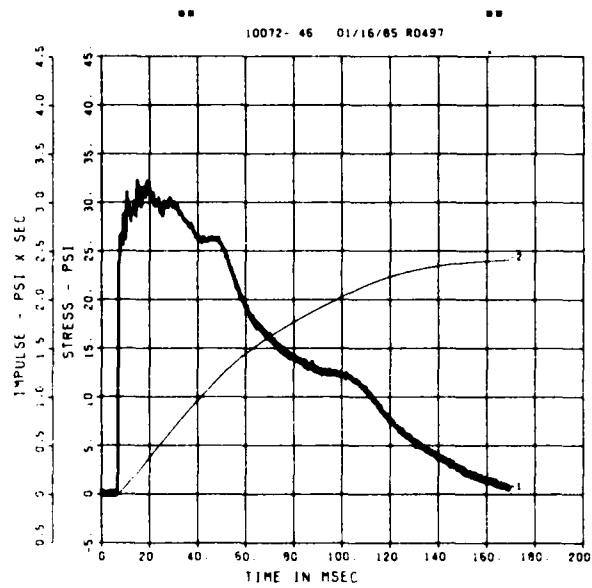

FEMA EXP SHELTER  
SE-5  
200000. HZ CAL= 52.40  
LP2/0 70% CUTOFF= 18000. HZ

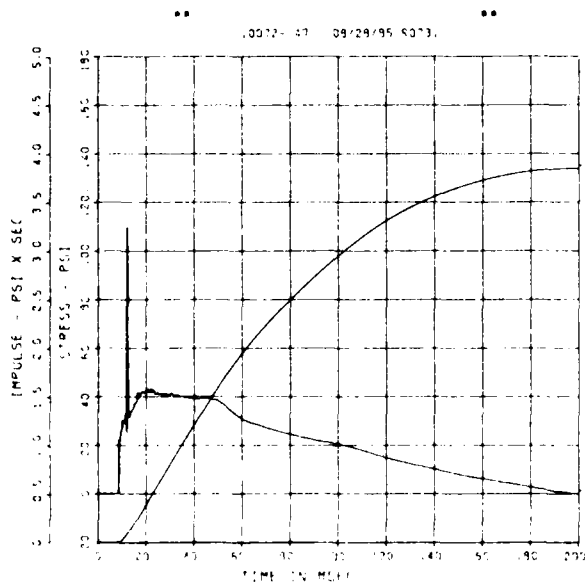

FEMA EXP SHELTER  
SE-6  
200000. HZ CAL= 39.90  
LP2/0 70% CUTOFF= 18000. HZ

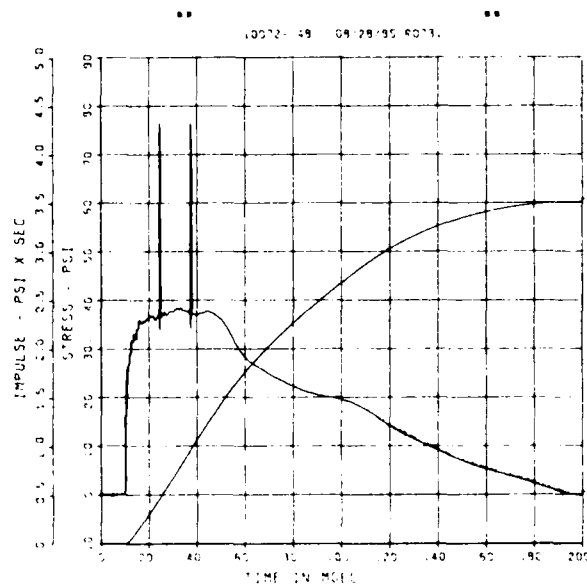

FEMA EXP SHELTER  
SE-7  
200000. HZ CAL= 38.90

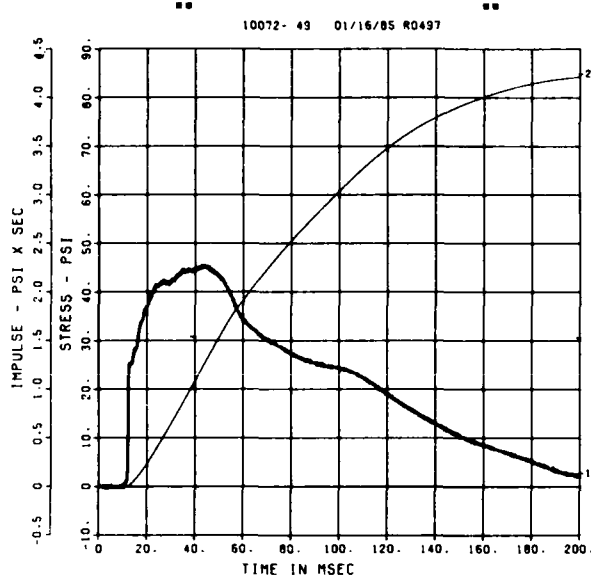

FEMA EXP SHELTER  
SE-8A  
200000. HZ CAL= 75.30  
LP2/O 70% CUTOFF= 18000. HZ

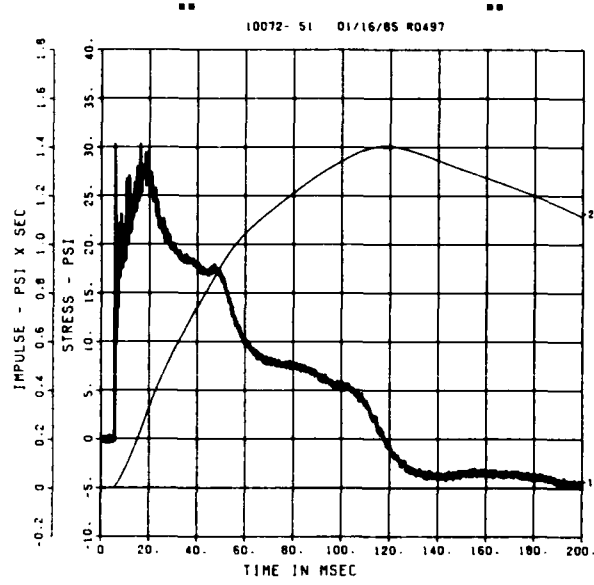

FEMA EXP SHELTER  
SE-8  
200000. HZ CAL= 123.2  
LP2/O 70% CUTOFF= 18000. HZ

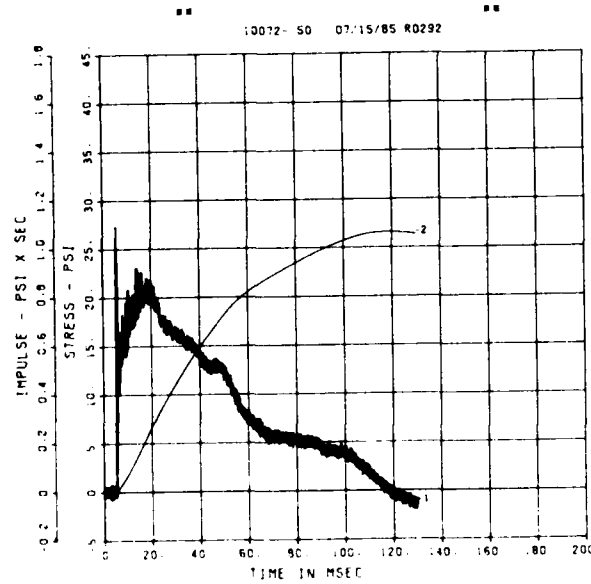

FEMA EXP SHELTER  
SE-9  
200000. HZ CAL= 74.80  
LP2/O 70% CUTOFF= 18000. HZ

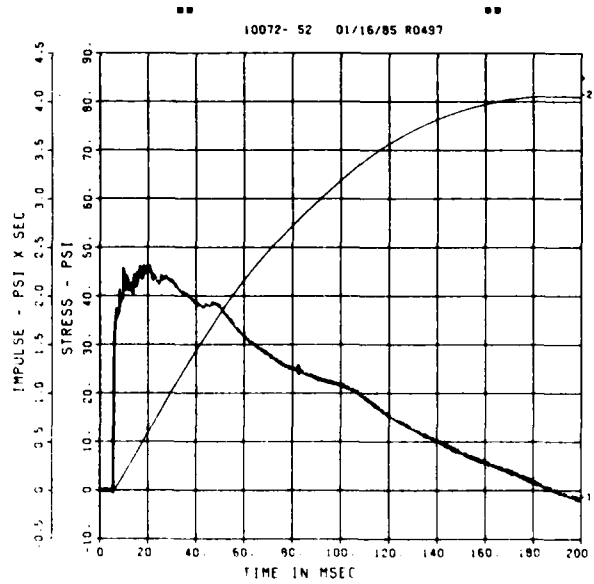

FEMA EXP SHELTER  
SE-10  
200000. HZ CAL= 52.40  
LP2/O 70% CUTOFF= 18000. HZ

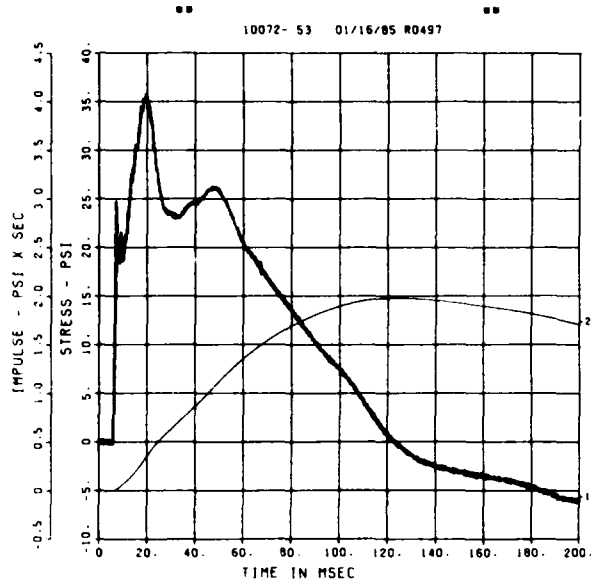

FEMA EXP SHELTER  
SE-11  
200000. HZ CAL= 51.70

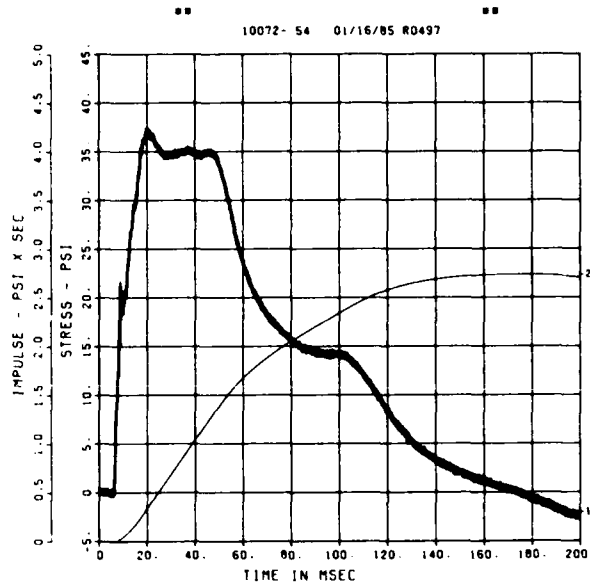

FEMA EXP SHELTER  
SE-11A  
200000. HZ CAL= 39.70

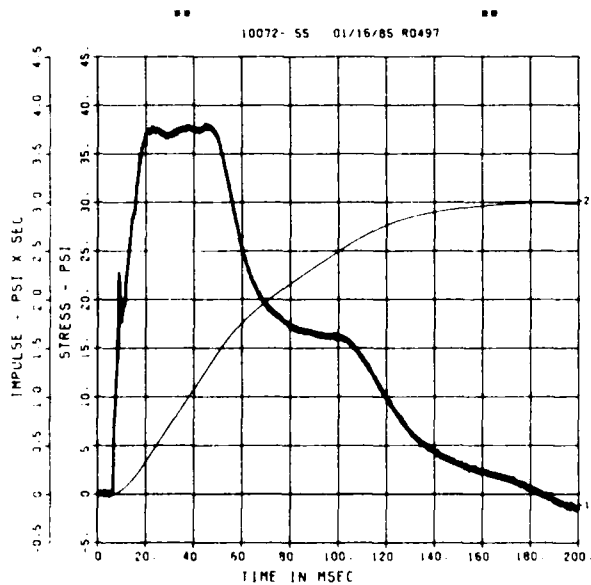

FEMA EXP SHELTER  
E-1  
200000. HZ CAL= 2058.  
LP2/O 70% CUTOFF= 18000. HZ

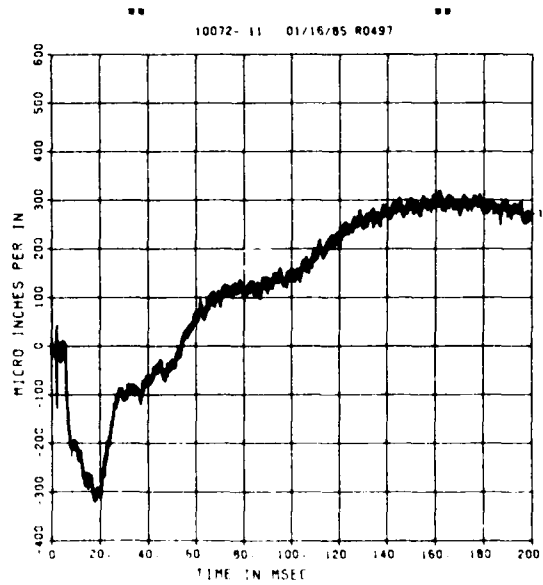

FEMA EXP SHELTER  
E-1A  
200000. HZ CAL= 2058.  
LP2/O 70% CUTOFF= 18000. HZ

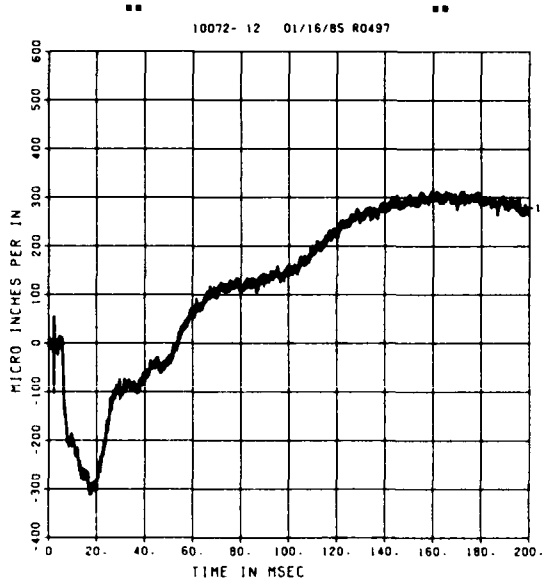

FEMA EXP SHELTER  
E-2  
200000. HZ CAL= 2058.  
LP2/O 70% CUTOFF= 18000. HZ

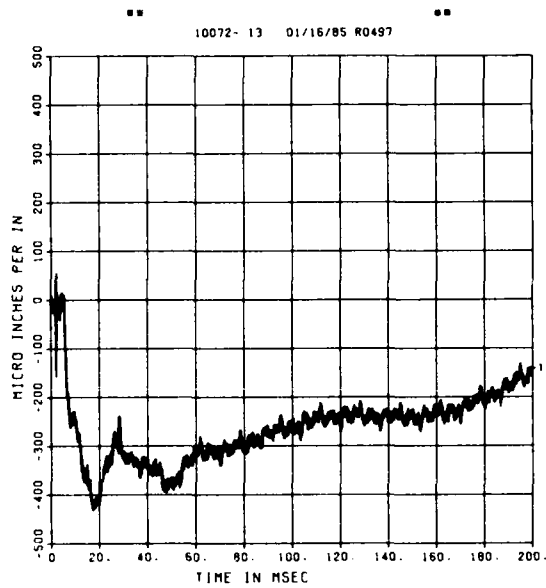

FEMA EXP SHELTER  
E-3  
200000. HZ CAL= 2058.  
LP2/O 70% CUTOFF= 18000. HZ

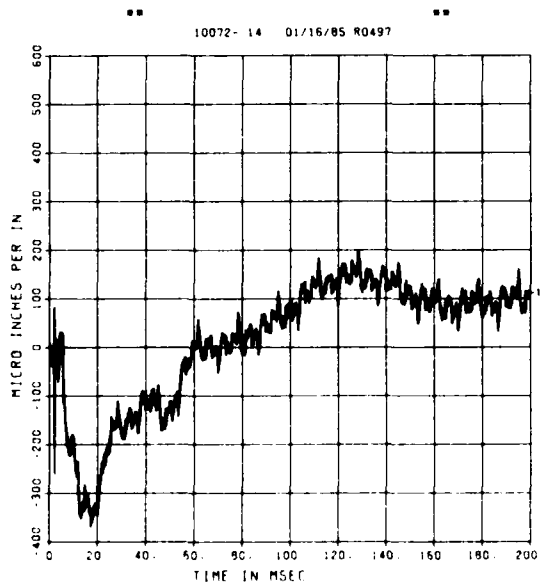

FEMA EXP SHELTER  
E-4  
200000. HZ CAL= 2058.  
LP2/O 70% CUTOFF= 18000. HZ

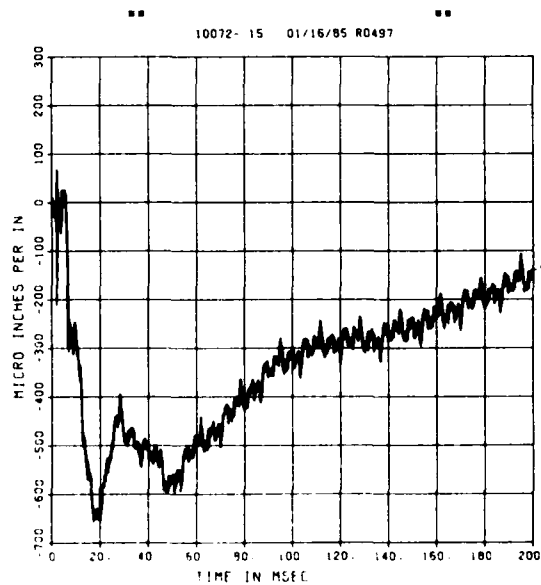

FEMA EXP SHELTER  
E-5  
200000. HZ CAL= 2058.  
LP2/O 70% CUTOFF= 18000. HZ

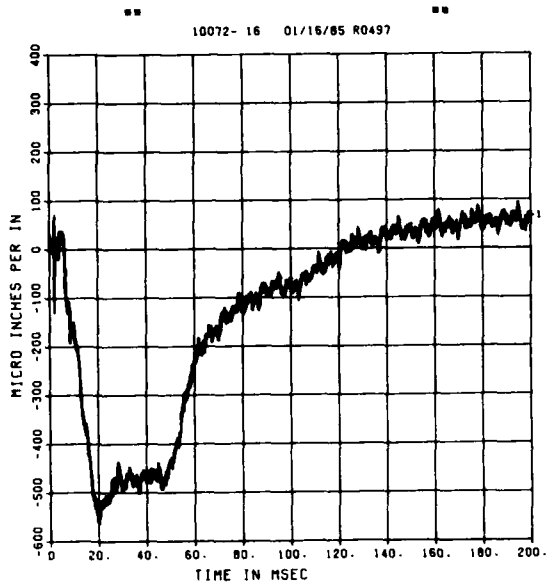

FEMA EXP SHELTER  
E-5A  
200000. HZ CAL= 2058.  
LP2/O 70% CUTOFF= 18000. HZ

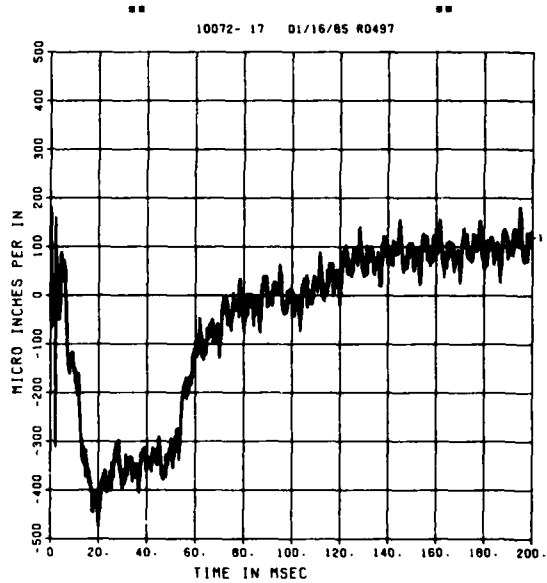

FEMA EXP SHELTER  
E-6  
200000. HZ CAL= 2058.  
LP2/O 70% CUTOFF= 18000. HZ

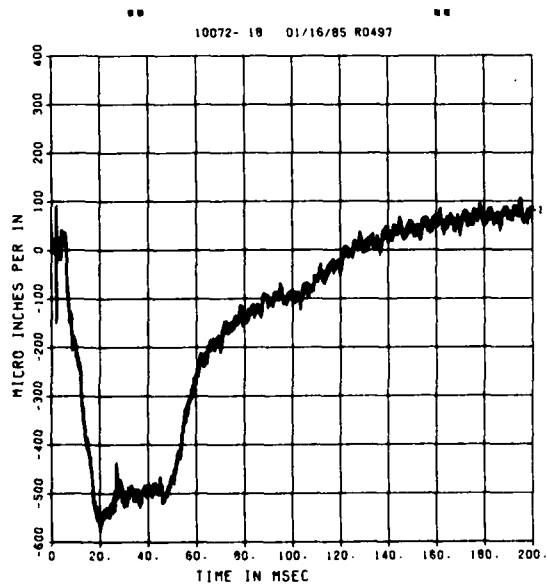

FEMA EXP SHELTER  
E-7  
200000. HZ CAL= 2058.  
LP2/O 70% CUTOFF= 18000. HZ

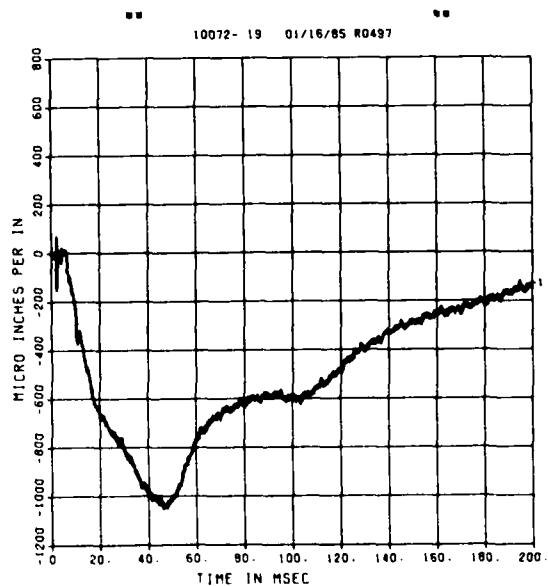

FEMA EXP SHELTER

E-8

200000. HZ CAL= 2058.

LP2/0 70% CUTOFF= 18000. HZ

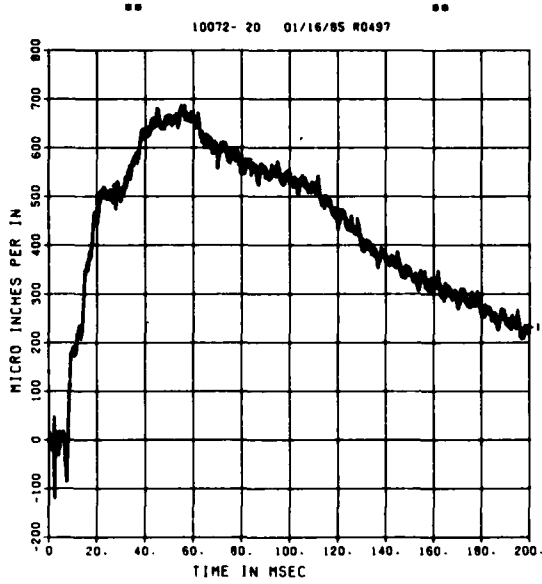

FEMA EXP SHELTER

E-9

200000. HZ CAL= 2058.

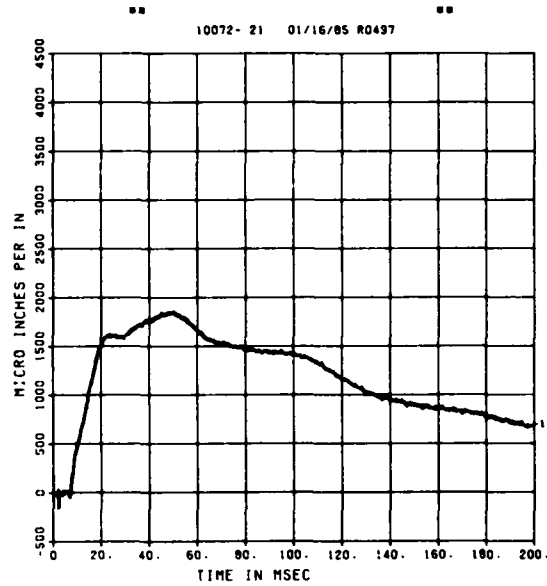

FEMA EXP SHELTER

E-10

50000. HZ CAL= 2058.

LP4/4 70% CUTOFF= 2250. HZ

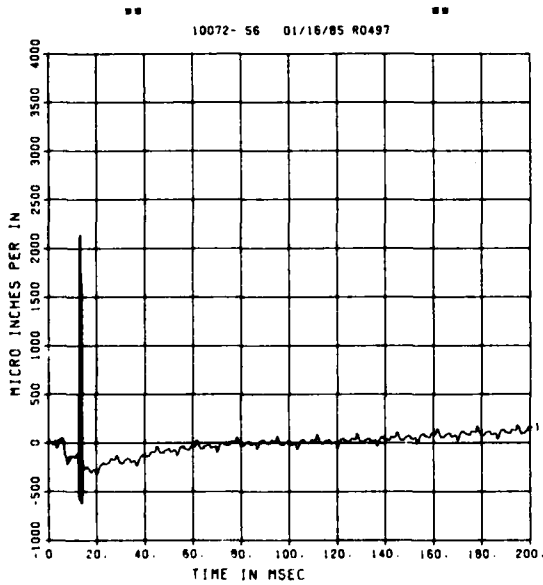

FEMA EXP SHELTER

E-11

50000. HZ CAL= 2058.

LP4/4 70% CUTOFF= 2250. HZ

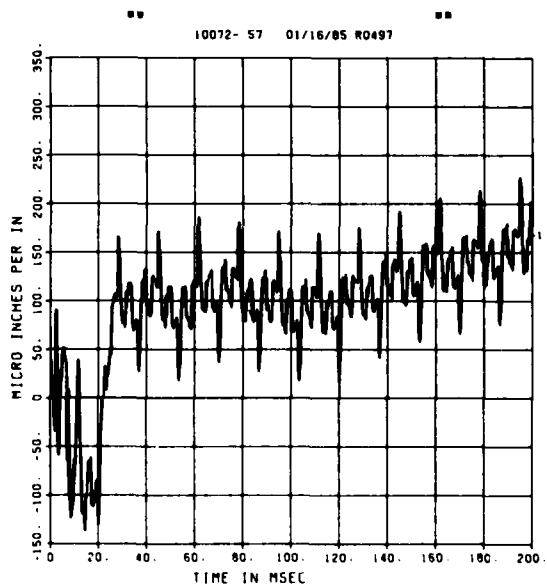

FEMA EXP SHELTER  
 E-12  
 50000. HZ CAL= 2058.  
 LP4/4 70% CUTOFF= 2250. HZ

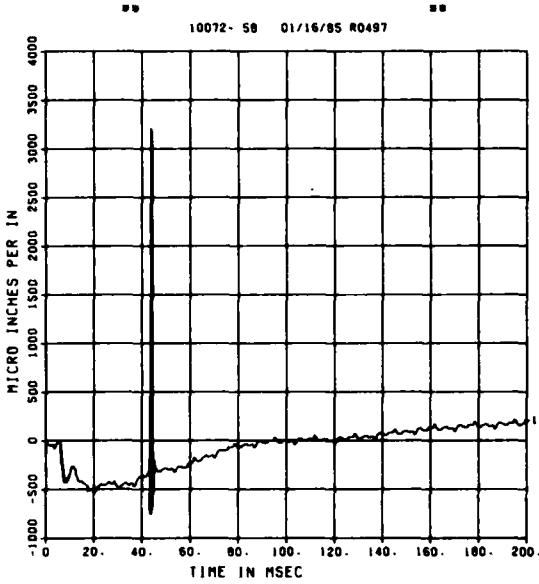

FEMA EXP SHELTER  
 E-13  
 50000. HZ CAL= 2058.  
 LP4/4 70% CUTOFF= 2250. HZ

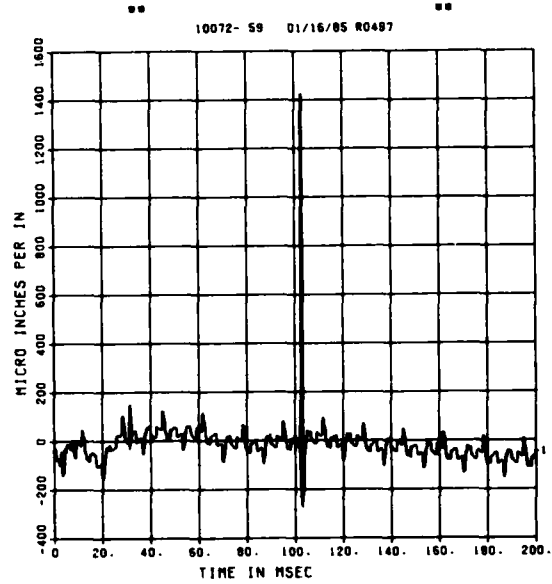

FEMA EXP SHELTER  
 AB-1  
 50000. HZ CAL= 12.90  
 LP4/4 70% CUTOFF= 2250. HZ

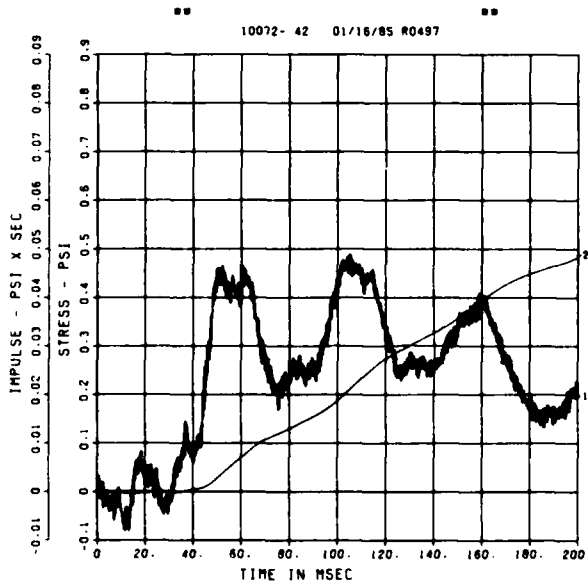

FEMA EXP SHELTER  
 AF-1  
 200000. HZ CAL= 263.0  
 LP4/0 70% CUTOFF= 9000. HZ

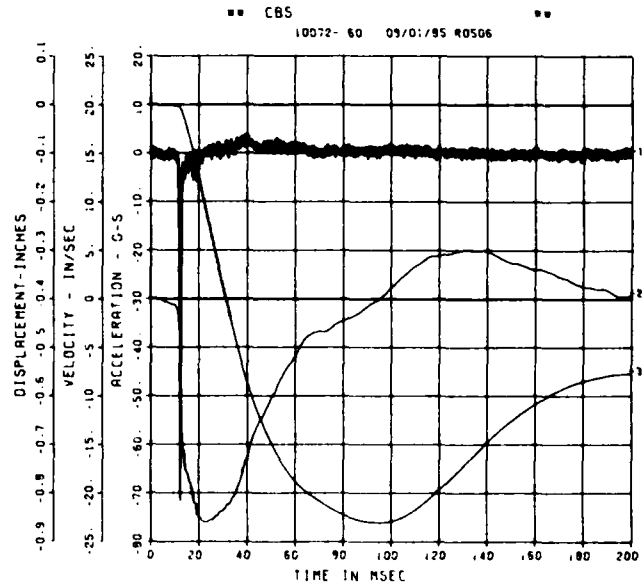

FEMA EXP SHELTER

A-1

200000. HZ CAL= 399.7  
LP4/O 70% CUTOFF= 9000. HZ

10072- 22 09/01/85 R0506

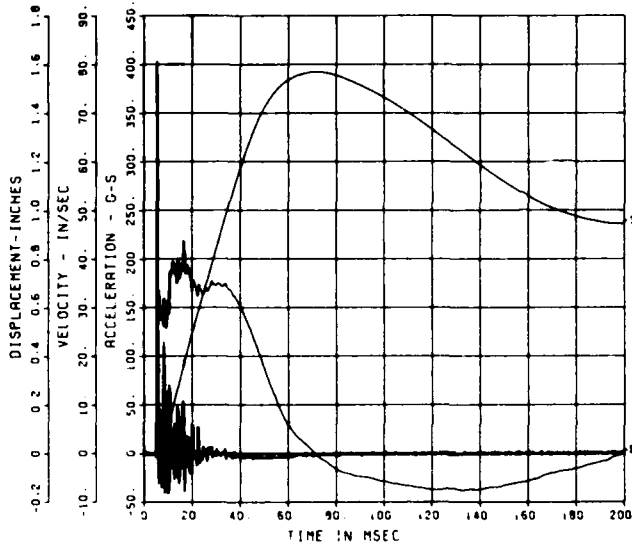

FEMA EXP SHELTER

A-2

200000. HZ CAL= 299.7  
LP4/O 70% CUTOFF= 9000. HZ

10072- 23 09/01/85 R0506

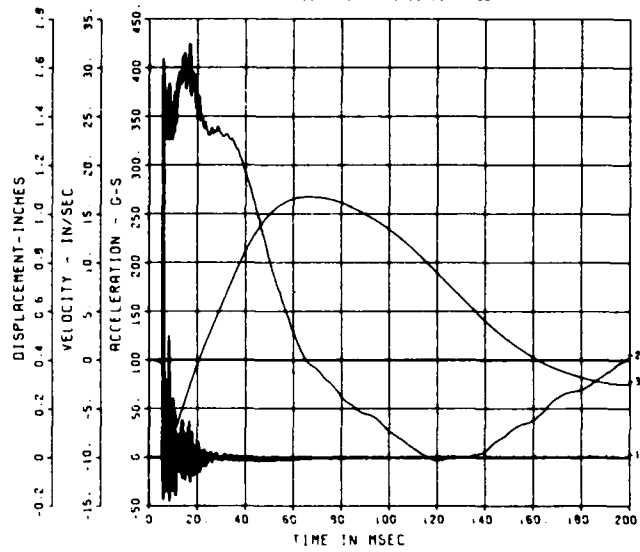

FEMA EXP SHELTER

A-3

200000. HZ CAL= 285.9  
LP4/O 70% CUTOFF= 9000. HZ

10072- 24 09/01/85 R0506

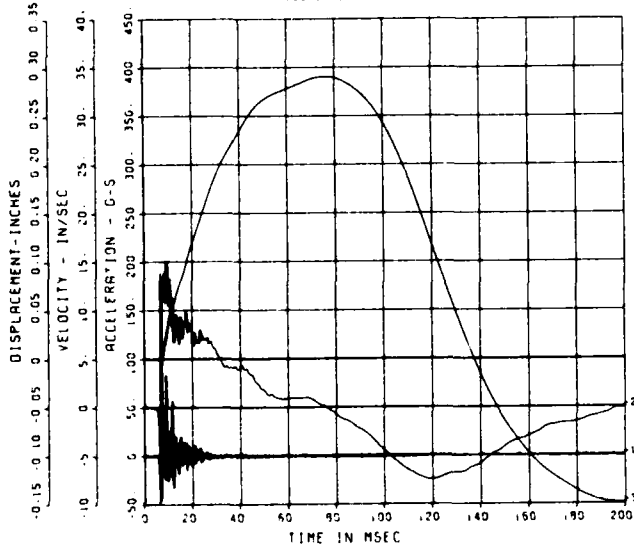

FEMA EXP SHELTER

A-4

200000. HZ CAL= 163.6  
LP4/O 70% CUTOFF= 9000. HZ

10072- 25 09/01/85 R0506

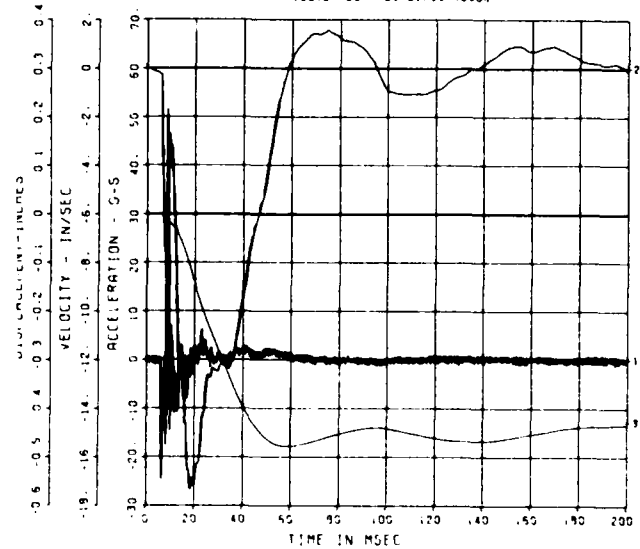

FEMA EXP SHELTER  
 A-5  
 200000. HZ CAL= 124.2  
 LP4/0 70% CUTOFF= 9000. HZ

\*\* CBS  
 10072- 26 09/01/85 R0506 \*\*

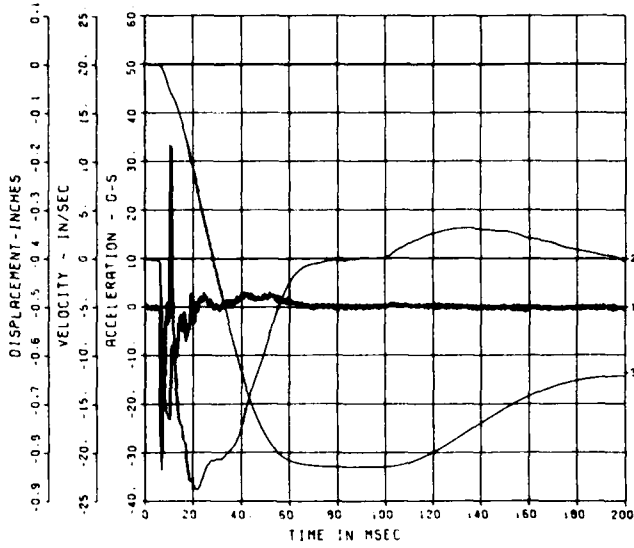

FEMA EXP SHELTER  
 A-6  
 200000. HZ CAL= 115.8  
 LP4/0 70% CUTOFF= 9000. HZ

\*\* CBS  
 10072- 27 09/01/85 R0506 \*\*

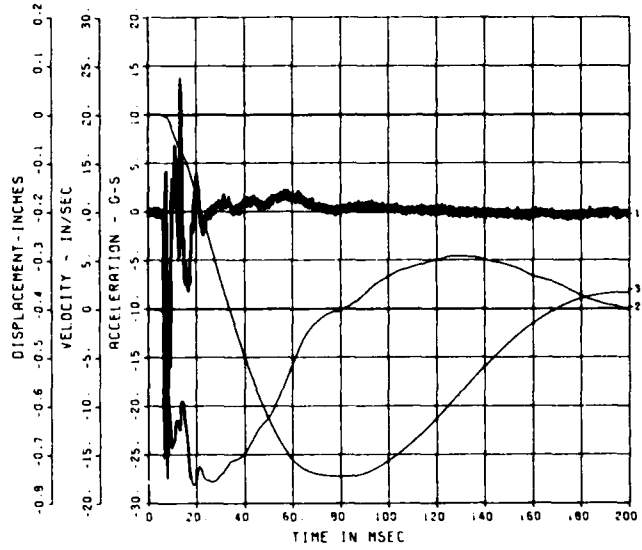

FEMA EXP SHELTER  
 A-7  
 200000. HZ CAL= 117.1  
 LP4/0 70% CUTOFF= 9000. HZ

\*\* CBS  
 10072- 28 09/22/85 R0694 \*\*

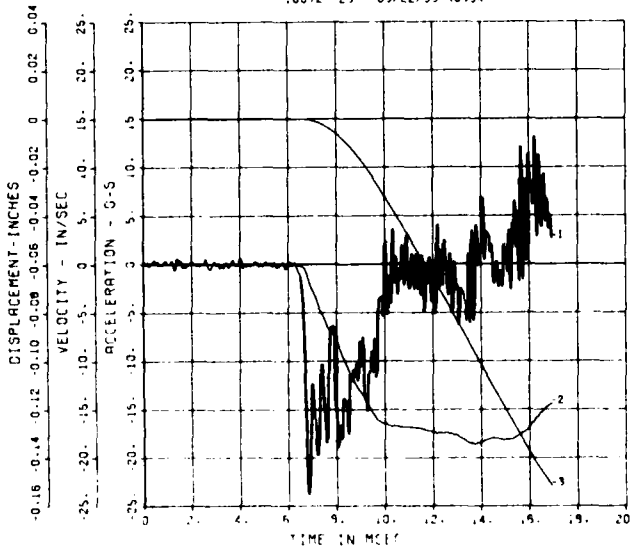

FEMA EXP SHELTER  
 A-8  
 50000. HZ CAL= 51.60  
 LP4/4 70% CUTOFF= 2250. HZ

\*\* CBS  
 10072- 29 09/06/85 R0591 \*\*

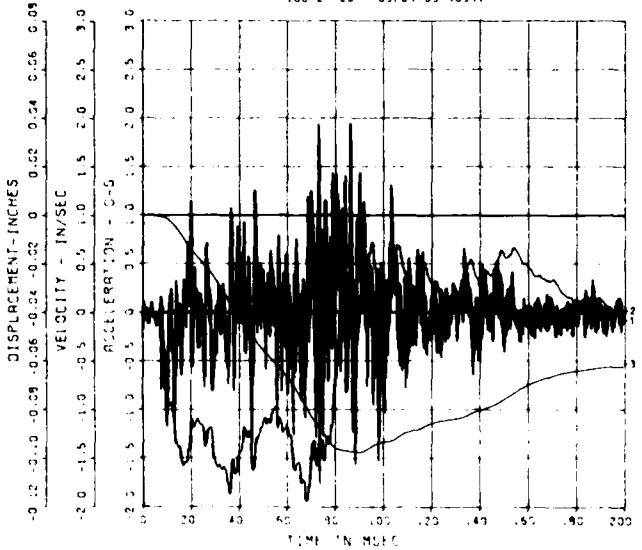

FEMA EXP SHELTER  
 A-9  
 50000. HZ CAL= 83.30  
 LP4/4 70% CUTOFF= 2250. HZ

\*\* CBS  
 10072- 30 09/01/85 R0566 \*\*

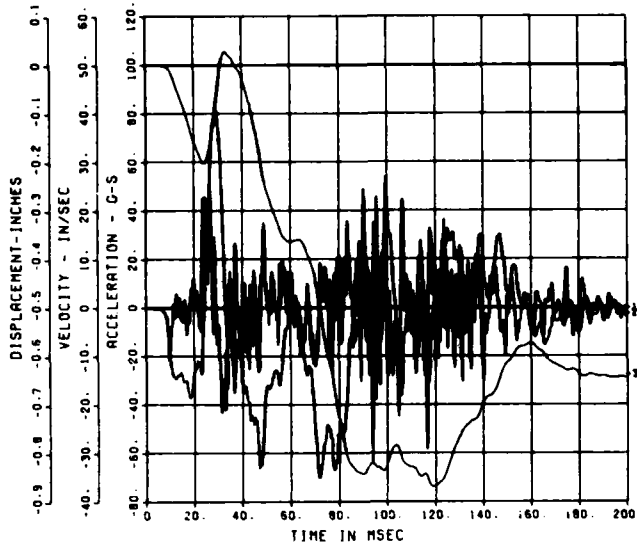

FEMA EXP SHELTER  
 ADX-1  
 12500. HZ CAL= 56.50  
 LP4/4 70% CUTOFF= 562.5 HZ

\*\* CBS  
 21458- 1 08/28/85 R0732 \*\*

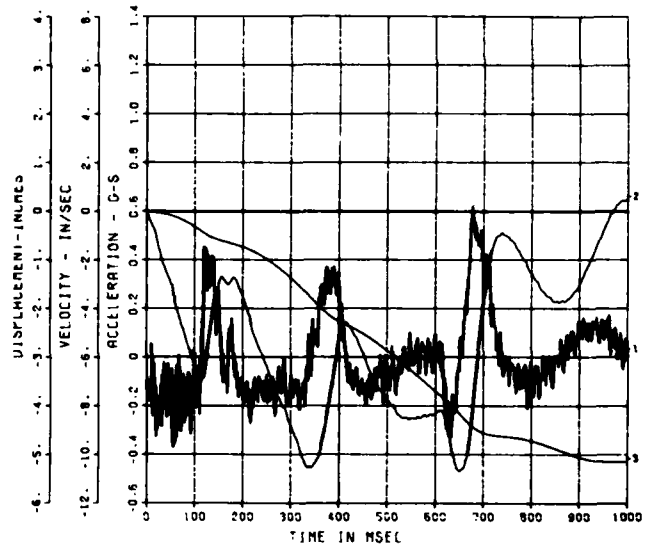

FEMA EXP SHELTER  
 ADY-1  
 12500. HZ CAL= 89.30  
 LP4/4 70% CUTOFF= 562.5 HZ

\*\* CBS  
 21459- 2 08/28/85 R0732 \*\*

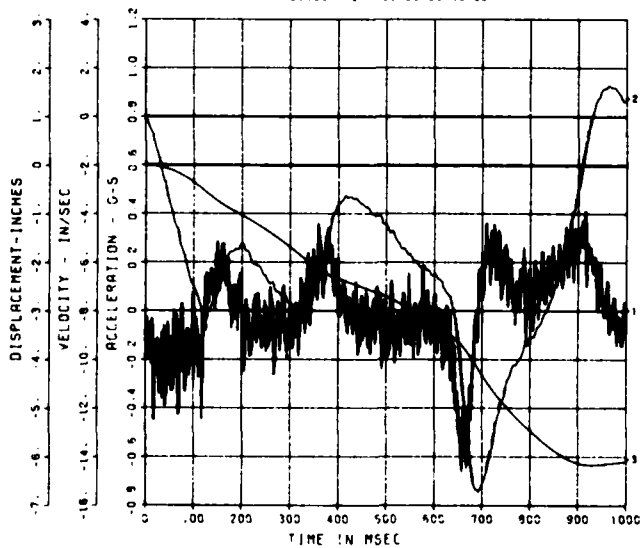

FEMA EXP SHELTER  
 ADZ-1  
 12500. HZ CAL= 56.90  
 LP4/4 70% CUTOFF= 562.5 HZ

\*\* CBS  
 21458- 3 08/28/85 R0732 \*\*

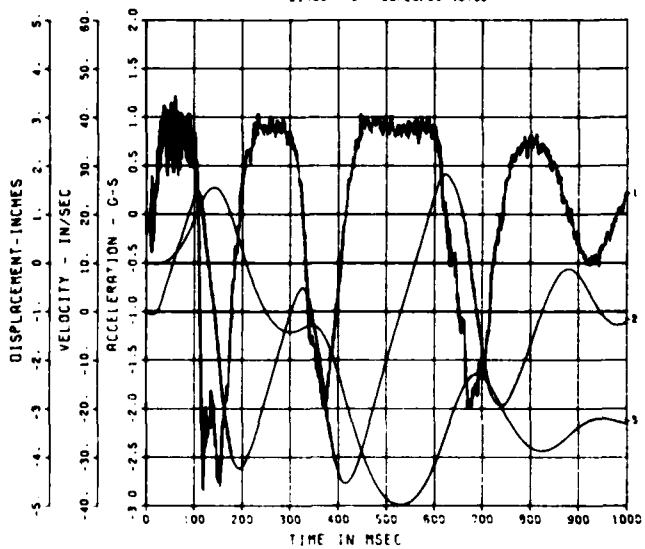

FEMA EXP SHELTER  
 ADX-2  
 20000. HZ CAL= 67.90  
 LP4/0 70% CUTOFF= 9000. HZ

== CBS ==  
 5572 - 4 08/21/85 R0884 ==

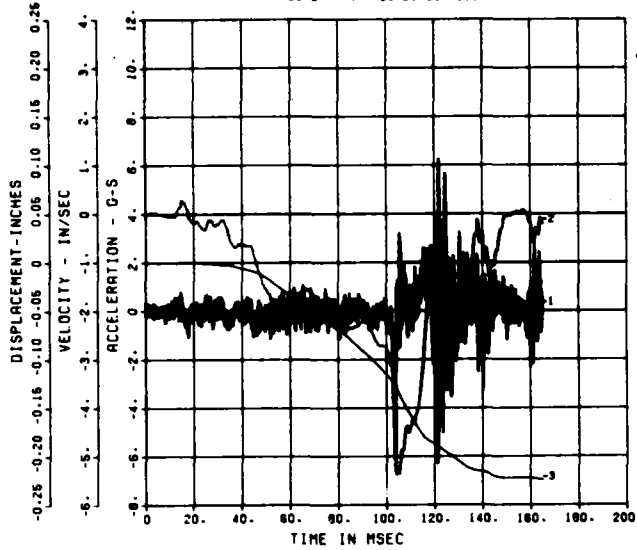

FEMA EXP SHELTER  
 ADY-2  
 50000. HZ CAL= 78.70  
 LP4/4 70% CUTOFF= 2250. HZ

== ==  
 10072- 35 01/16/85 R0497 ==

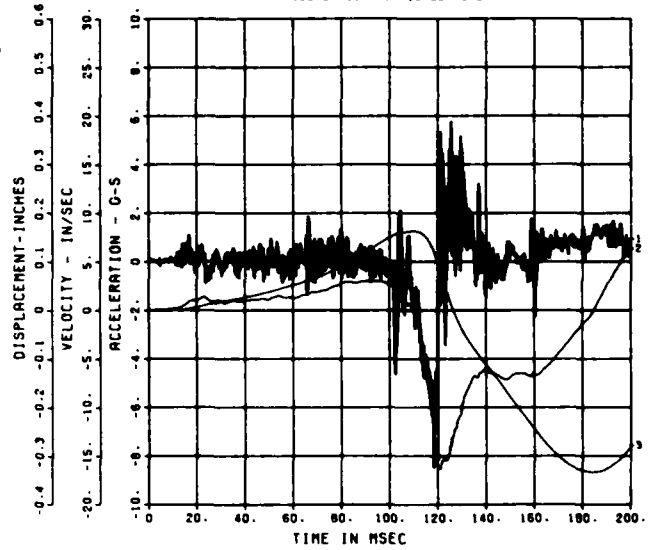

FEMA EXP SHELTER  
 ADY-2  
 20000. HZ CAL= 78.70  
 LP4/0 70% CUTOFF= 9000. HZ

== CBS ==  
 5572 - 5 08/21/85 R0884 ==

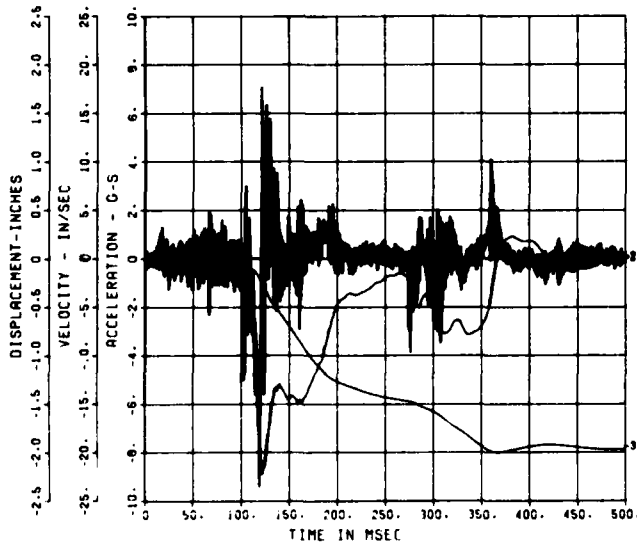

FEMA EXP SHELTER  
 ADZ-2  
 12500. HZ CAL= 52.30  
 LP4/4 70% CUTOFF= 562.5 HZ

== CBS ==  
 21458 - 4 08/28/85 R0732 ==

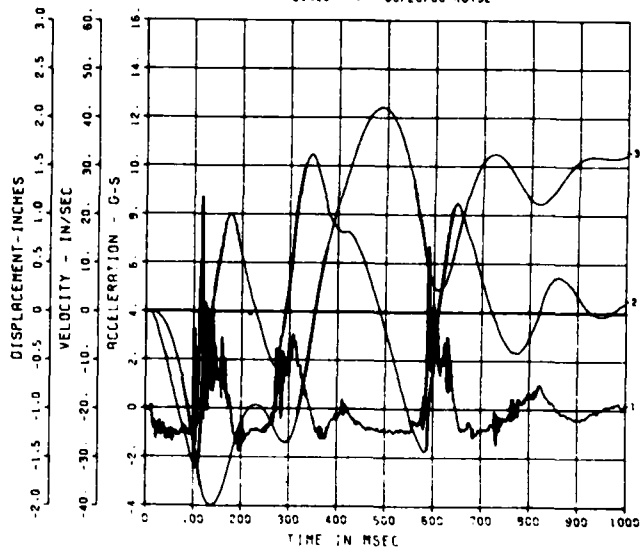

FEMA EXP SHELTER  
 ADX-3  
 200000. HZ CAL= 50.10  
 LP4/O 70% CUTOFF= 9000. HZ

5572 - 7 09/21/95 R0894

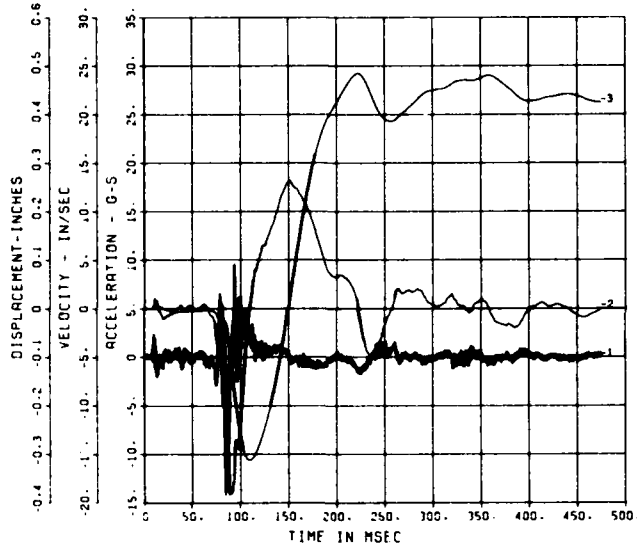

FEMA EXP SHELTER  
 ADY-3  
 200000. HZ CAL= 88.10  
 LP4/O 70% CUTOFF= 9000. HZ

5572 - 8 09/28/95 R0730

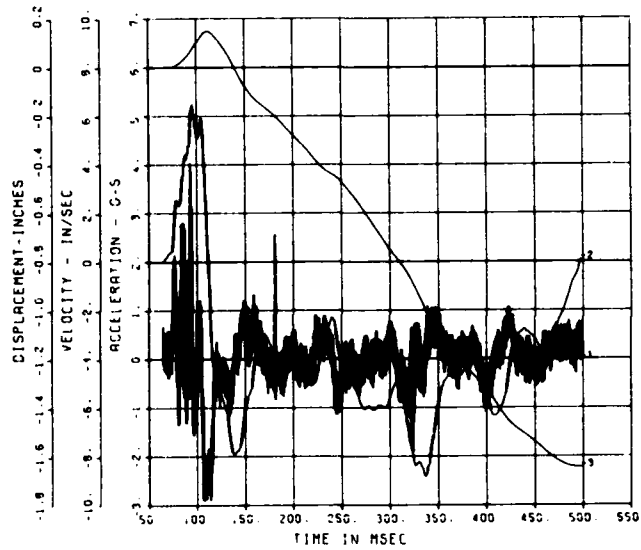

FEMA EXP SHELTER  
 ADZ-3  
 12500. HZ CAL= 62.80  
 LP4/O 70% CUTOFF= 5500. HZ

21459 - 6 09/29/95 R0132

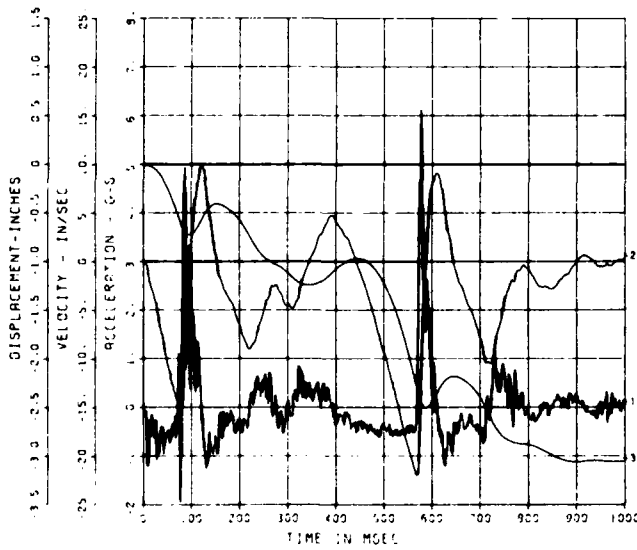

FEMA EXP SHELTER  
 BP-1  
 200000. HZ CAL= 365.4  
 LP2/O 70% CUTOFF= 18000. HZ

10072 - 1 01/16/85 R0497

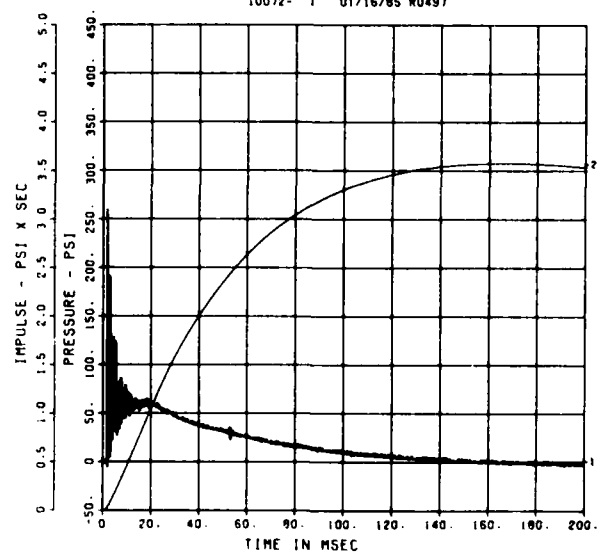

FEMA EXP SHELTER  
 BP-2  
 200000. HZ CAL= 302.5  
 LP2/O 70% CUTOFF= 18000. HZ

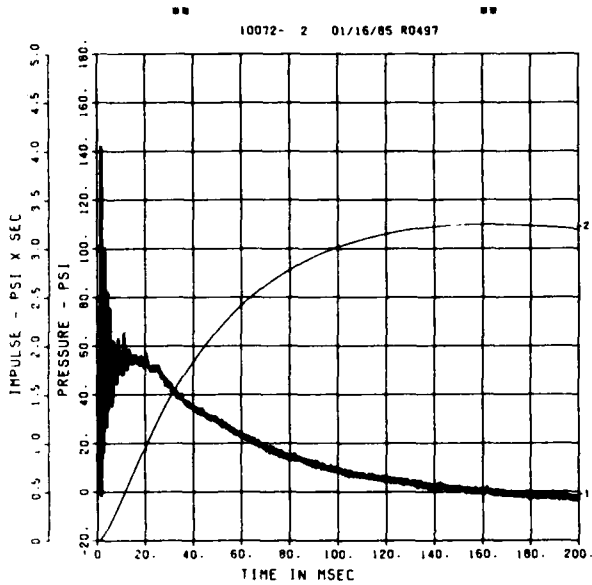

FEMA EXP SHELTER  
 BP-3  
 200000. HZ CAL= 367.7  
 LP2/O 70% CUTOFF= 18000. HZ

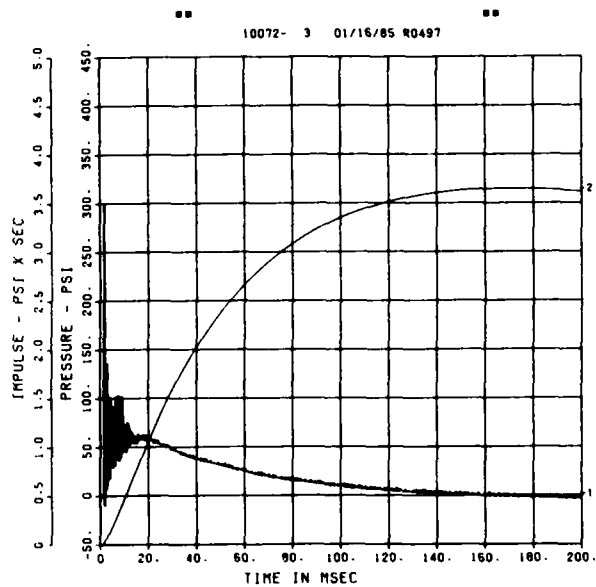

FEMA EXP SHELTER  
 BP-4  
 200000. HZ CAL= 330.0  
 LP2/O 70% CUTOFF= 18000. HZ

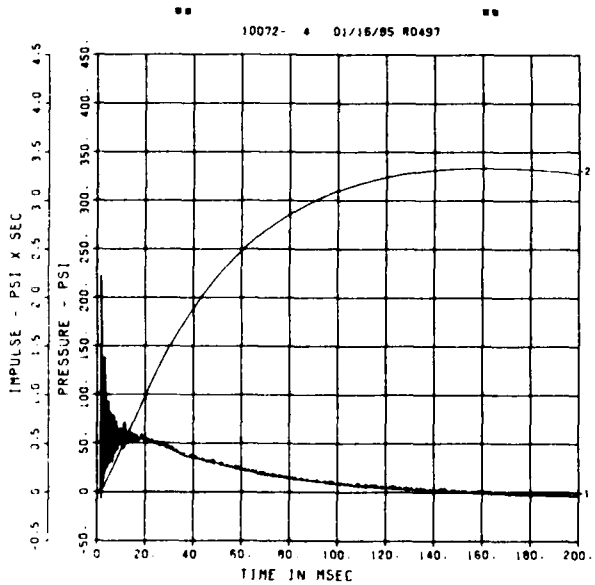

FEMA EXP SHELTER  
 BP-5  
 200000. HZ CAL= 324.8  
 LP2/O 70% CUTOFF= 18000. HZ

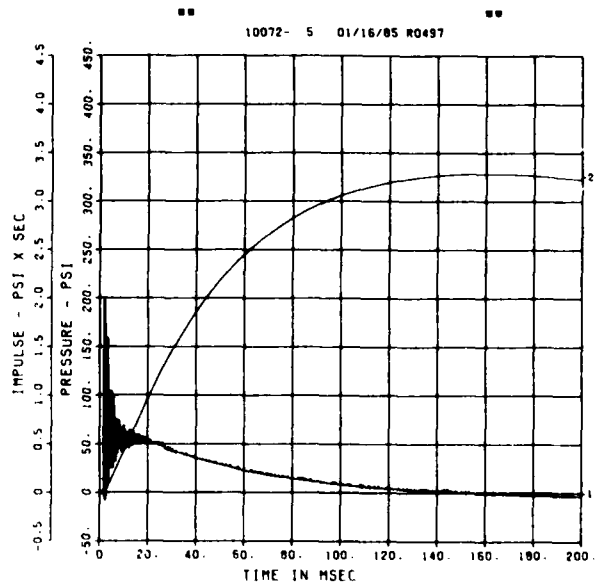

FEMA EXP SHELTER  
 BP-6  
 200000. HZ CAL= 319.9  
 LP2/O 70% CUTOFF= 18000. HZ

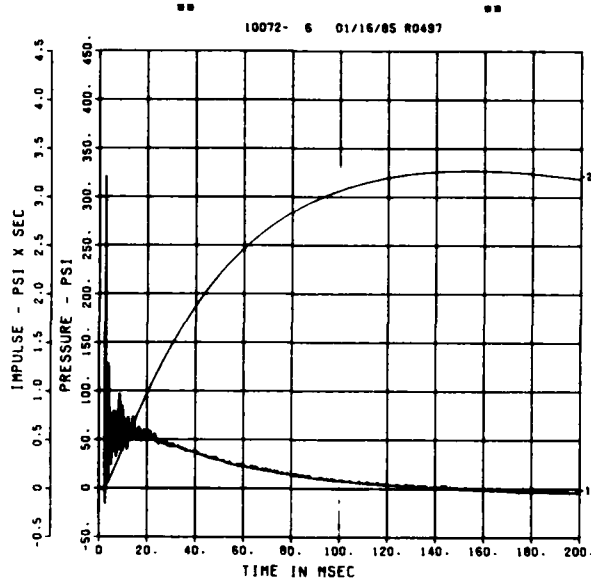

FEMA EXP SHELTER  
 BP-7  
 200000. HZ CAL= 340.1  
 LP2/O 70% CUTOFF= 18000. HZ

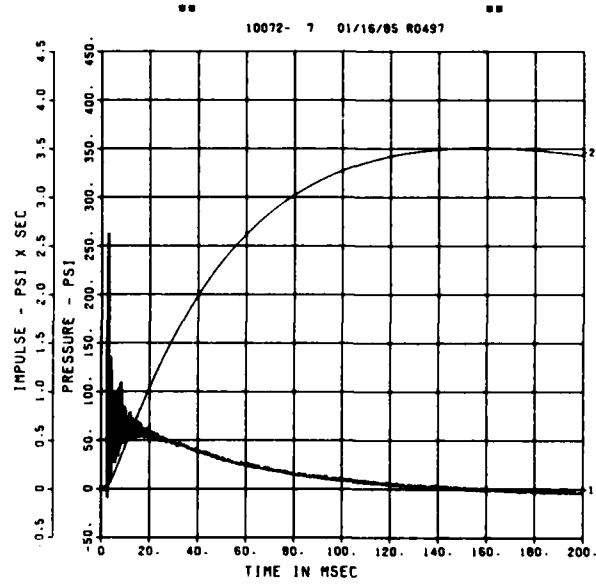

FEMA EXP SHELTER  
 BP-9  
 200000. HZ CAL= 316.8  
 LP2/O 70% CUTOFF= 18000. HZ

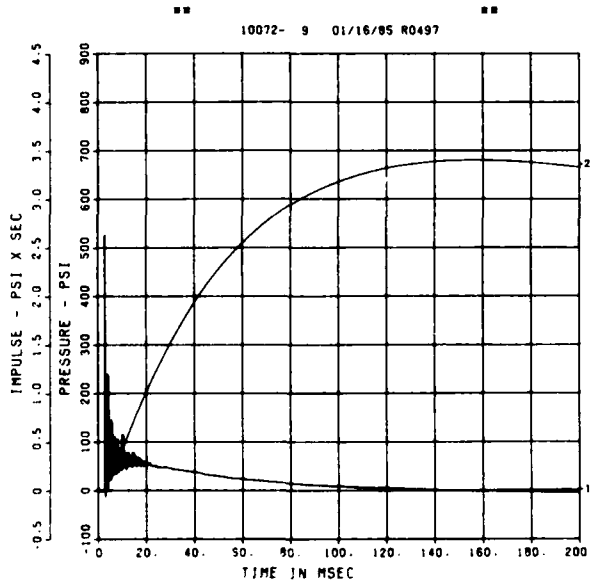

FEMA EXP SHELTER  
 BP-10  
 200000. HZ CAL= 317.7  
 LP2/O 70% CUTOFF= 18000. HZ

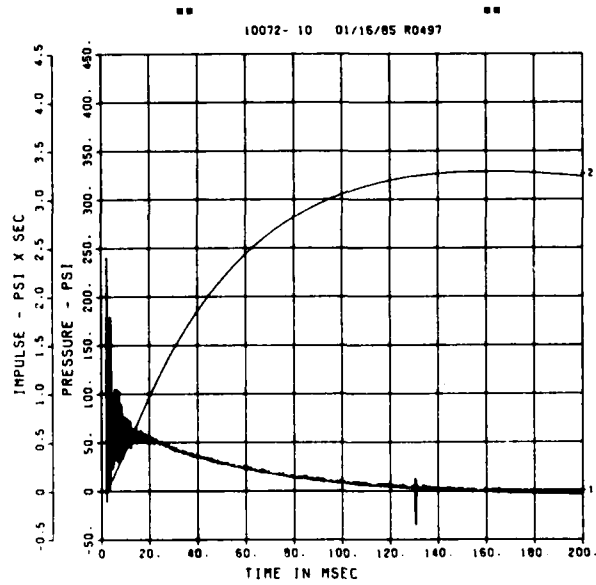

**Appendix C**  
**NUCLEAR WEAPON SIMULATIONS**

PRESSURE COMPARISON  
 FEMA EXP SHELTER  
 BP 1  
 SPEICHER-BRODE  
 WIKT) = 1000.000  
 P(PSI) = 57.  
 HOBFI(KFT) = 0.  
 01/25/95 14438

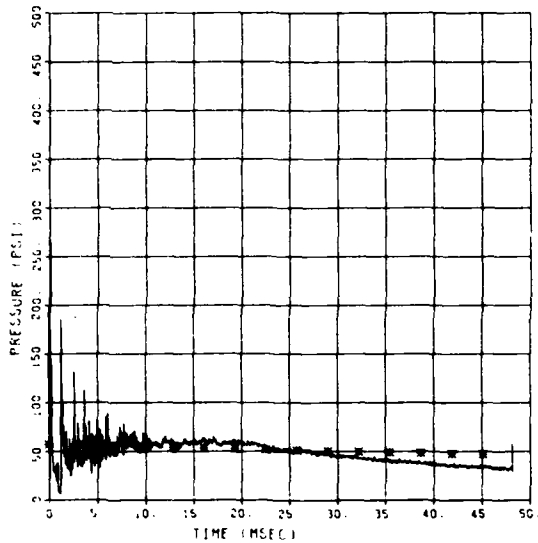

IMPULSE COMPARISON  
 FEMA EXP SHELTER  
 BP 1  
 SPEICHER-BRODE  
 WIKT) = 1000.000  
 P(PSI) = 57.  
 HOBFI(KFT) = 0.  
 01/25/95 14438

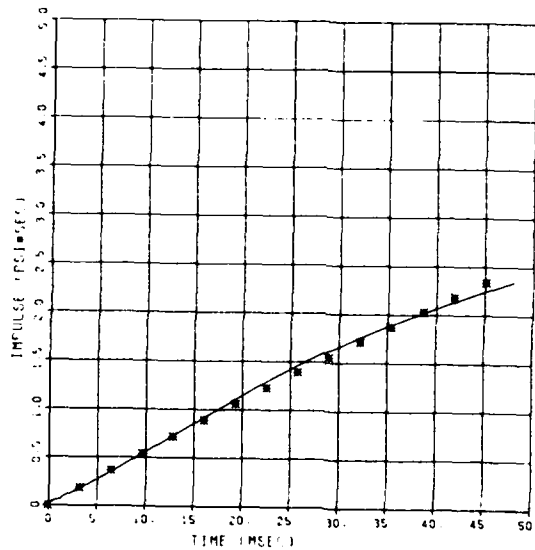

PRESSURE COMPARISON  
 FEMA EXP SHELTER  
 BP 2  
 SPEICHER-BRODE  
 WIKT) = 1000.000  
 P(PSI) = 52.  
 HOBFI(KFT) = 0.  
 01/25/95 14438

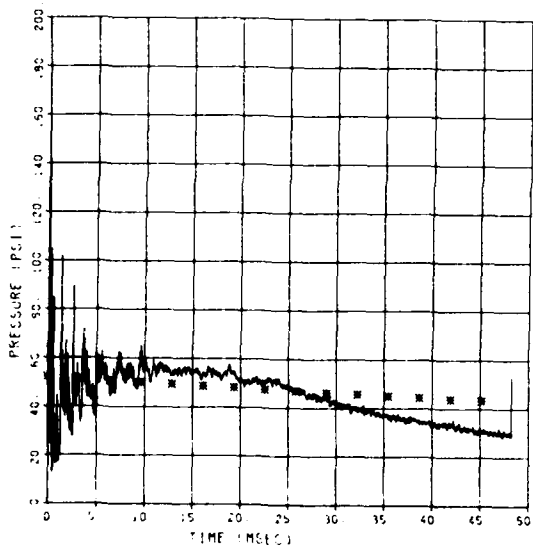

IMPULSE COMPARISON  
 FEMA EXP SHELTER  
 BP 2  
 SPEICHER-BRODE  
 WIKT) = 1000.000  
 P(PSI) = 52.  
 HOBFI(KFT) = 0.  
 01/25/95 14438

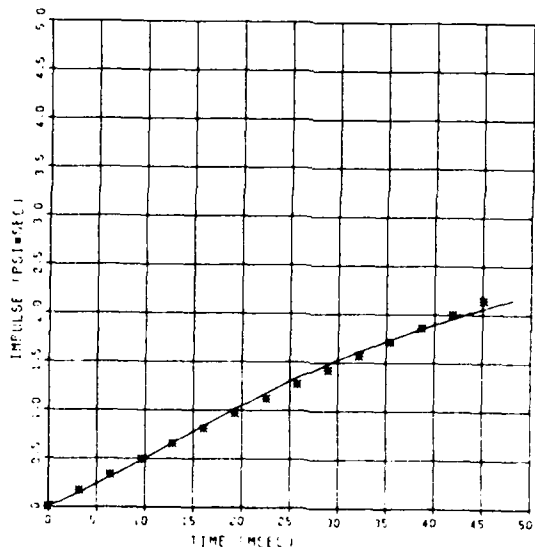

PRESSURE COMPARISON  
 FEMA EXP SHELTER  
 BP-3  
 SPEICHER-BRODE  
 W(KT) = 1000.000  
 P(PSI) = 58.  
 HOBFI(KFT) = 0.  
 01/09/95 74438

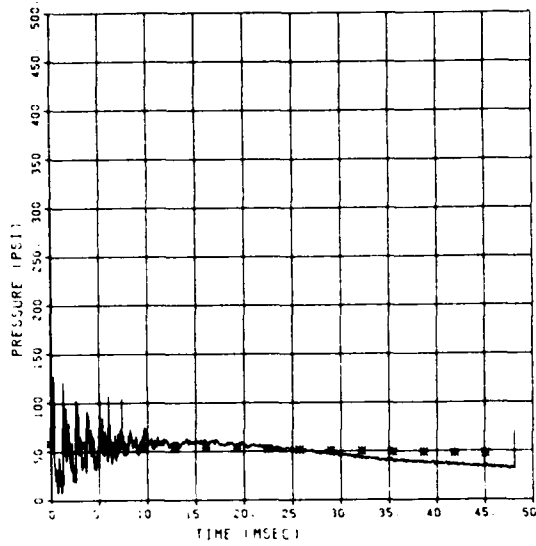

IMPULSE COMPARISON  
 FEMA EXP SHELTER  
 BP-3  
 SPEICHER-BRODE  
 W(KT) = 1000.000  
 P(PSI) = 58.  
 HOBFI(KFT) = 0.  
 01/09/95 74438

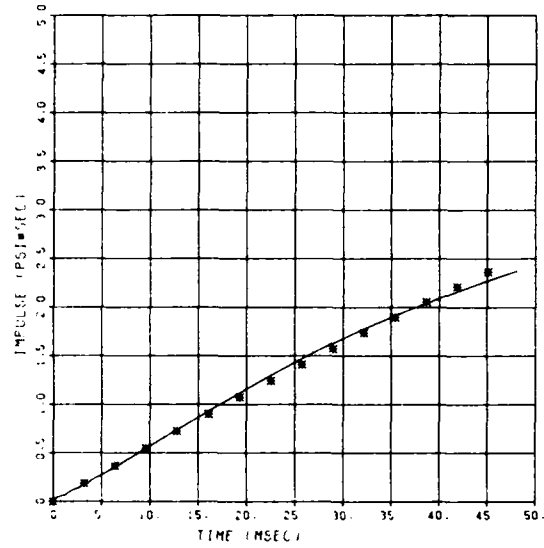

PRESSURE COMPARISON  
 FEMA EXP SHELTER  
 BP-4  
 SPEICHER-BRODE  
 W(KT) = 1000.000  
 P(PSI) = 54.  
 HOBFI(KFT) = 0.  
 01/09/95 74438

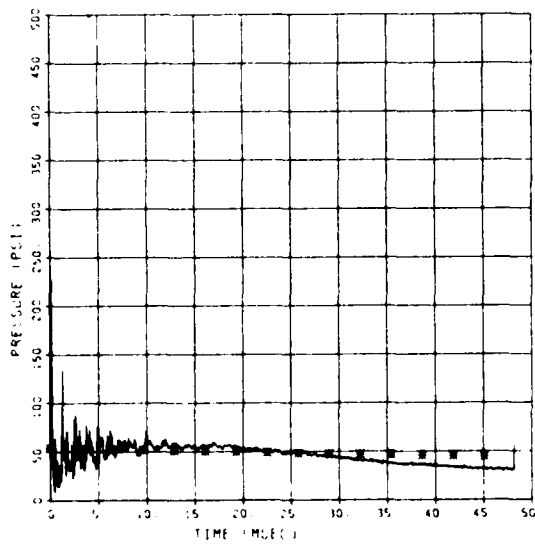

IMPULSE COMPARISON  
 FEMA EXP SHELTER  
 BP-4  
 SPEICHER-BRODE  
 W(KT) = 1000.000  
 P(PSI) = 54.  
 HOBFI(KFT) = 0.  
 01/09/95 74438

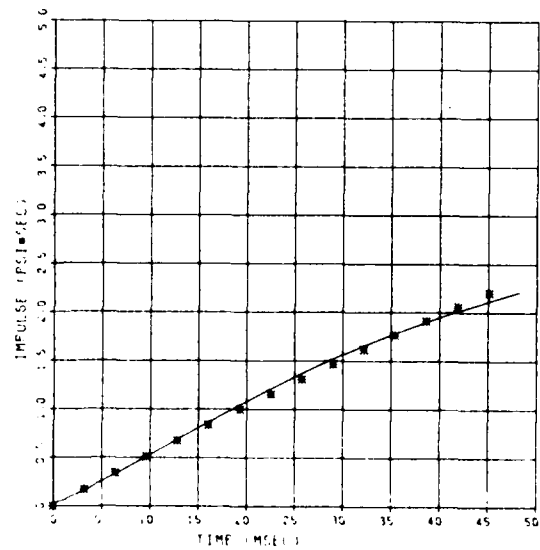

PRESSURE COMPARISON  
 FEMA EXP SHELTER  
 BP-5  
 SPEICHER-BRODE  
 W(KT) = 1000.000  
 P(PST) = 53.  
 HOB(FKFT) = 0.  
 01/09/85 74438

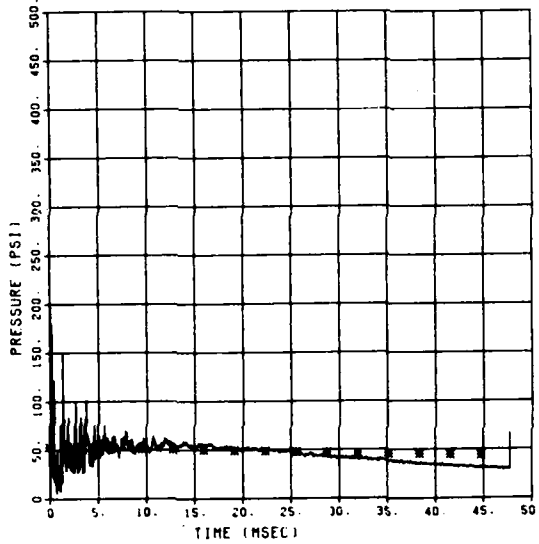

IMPULSE COMPARISON  
 FEMA EXP SHELTER  
 BP-5  
 SPEICHER-BRODE  
 W(KT) = 1000.000  
 P(PST) = 53.  
 HOB(FKFT) = 0.  
 01/09/85 74438

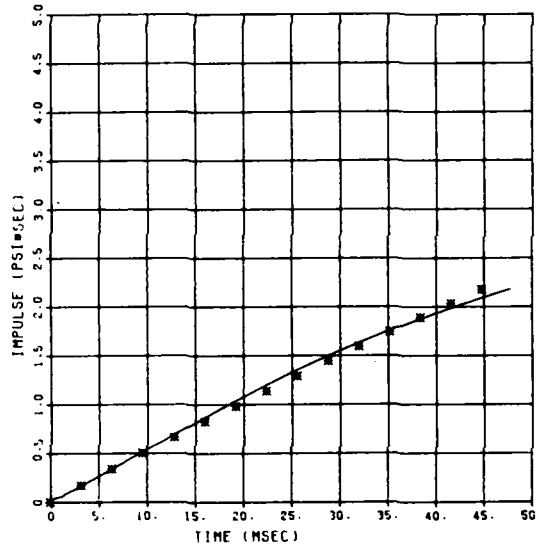

PRESSURE COMPARISON  
 FEMA EXP SHELTER  
 BP-6  
 SPEICHER-BRODE  
 W(KT) = 1000.000  
 P(PST) = 55.  
 HOB(FKFT) = 0.  
 01/09/85 74438

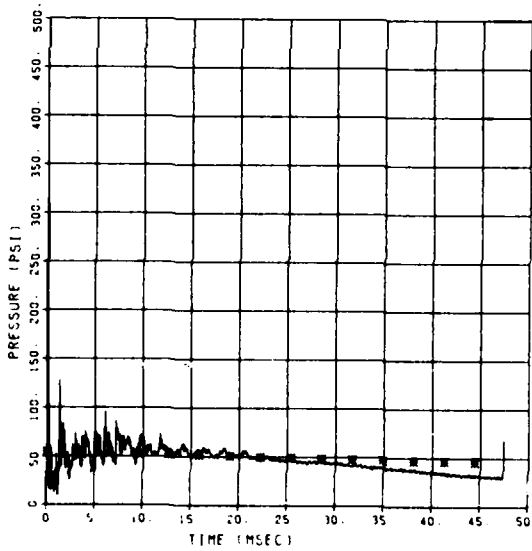

IMPULSE COMPARISON  
 FEMA EXP SHELTER  
 BP-6  
 SPEICHER-BRODE  
 W(KT) = 1000.000  
 P(PST) = 55.  
 HOB(FKFT) = 0.  
 01/09/85 74438

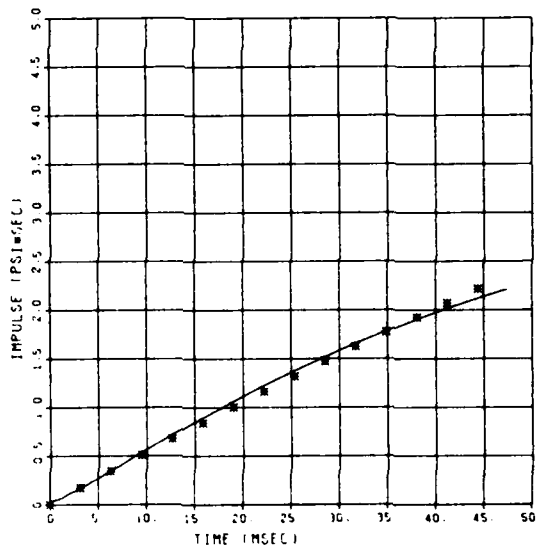

PRESSURE COMPARISON  
 FEMA EXP SHELTER  
 BP-7  
 SPEICHER-BRODE  
 W(KT) = 1000.000  
 P(PST) = 58.  
 HOBF(KFT) = 0.  
 01/09/85 74438

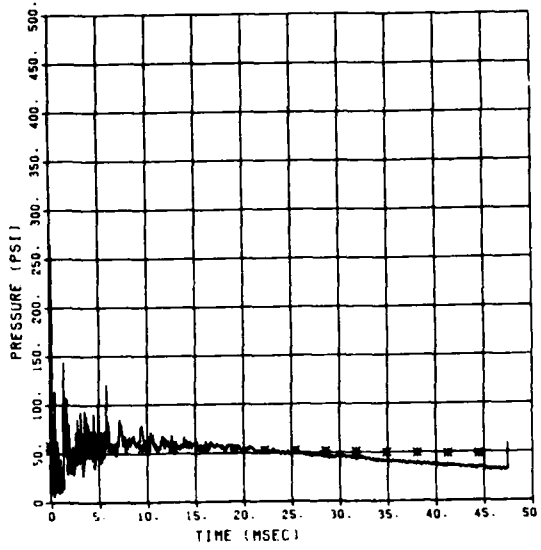

IMPULSE COMPARISON  
 FEMA EXP SHELTER  
 BP-7  
 SPEICHER-BRODE  
 W(KT) = 1000.000  
 P(PST) = 58.  
 HOBF(KFT) = 0.  
 01/09/85 74438

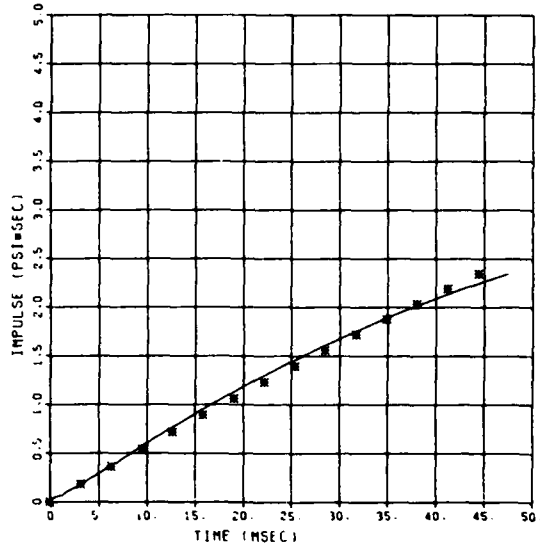

PRESSURE COMPARISON  
 FEMA EXP SHELTER  
 BP-9  
 SPEICHER-BRODE  
 W(KT) = 1000.000  
 P(PST) = 57.  
 HOBF(KFT) = 0.  
 01/09/85 74438

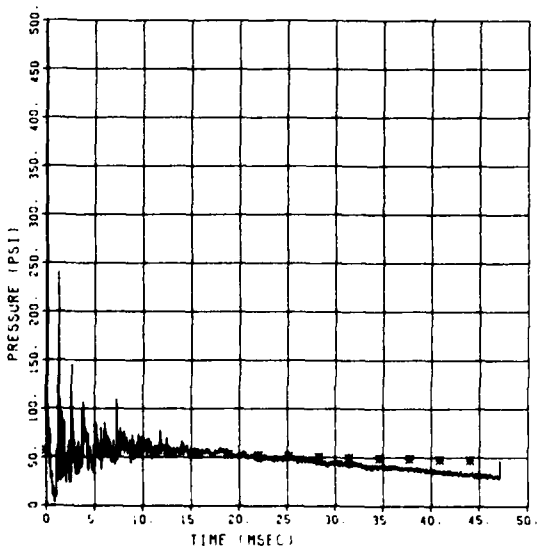

IMPULSE COMPARISON  
 FEMA EXP SHELTER  
 BP-9  
 SPEICHER-BRODE  
 W(KT) = 1000.000  
 P(PST) = 57.  
 HOBF(KFT) = 0.  
 01/09/85 74438

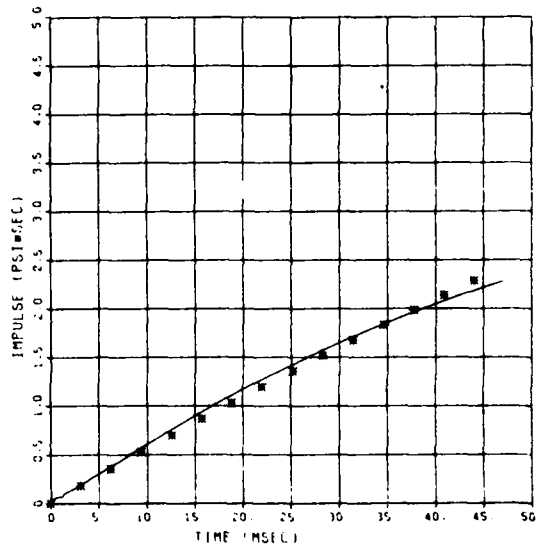

PRESSURE COMPARISON  
 FEMA EXP SHELTER  
 BP-10  
 SPEICHER-BRODE  
 W(KT) = 1000.000  
 P(PSI) = 54.  
 HOB(FKFT) = 0.  
 01/09/85 74438

IMPULSE COMPARISON  
 FEMA EXP SHELTER  
 BP-10  
 SPEICHER-BRODE  
 W(KT) = 1000.000  
 P(PSI) = 54.  
 HOB(FKFT) = 0.  
 01/09/85 74438

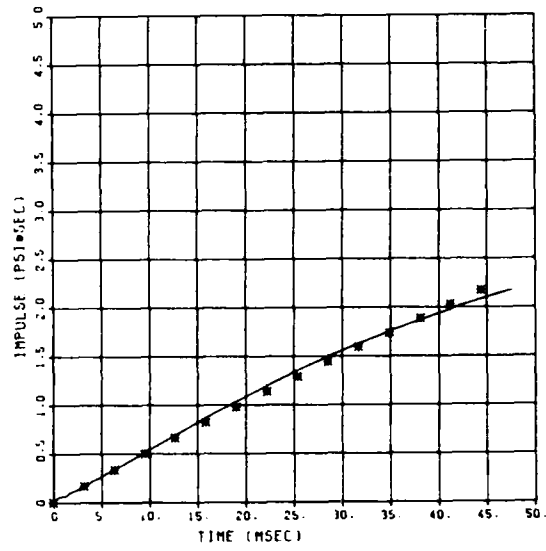
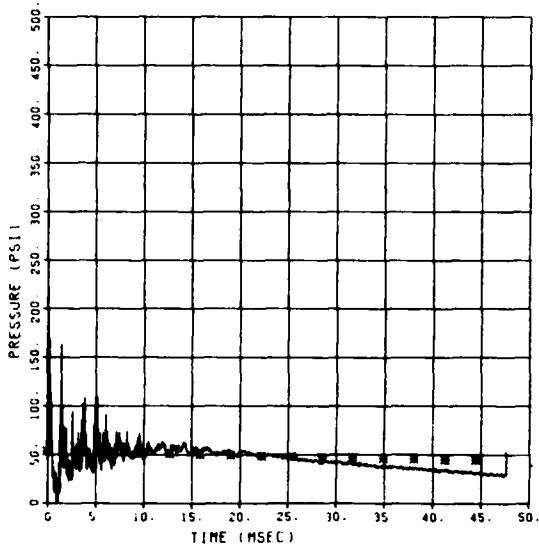

PRESSURE COMPARISON  
 FEMA EXP SHELTER  
 6P-10  
 SPEICHER-BRODE  
 W(KT) = 1000.000  
 P(PSI) = 55.  
 HOB(FKFT) = 0.  
 01/09/85 75538

IMPULSE COMPARISON  
 FEMA EXP SHELTER  
 6P-10  
 SPEICHER-BRODE  
 W(KT) = 1000.000  
 P(PSI) = 55.  
 HOB(FKFT) = 0.  
 01/09/85 75538

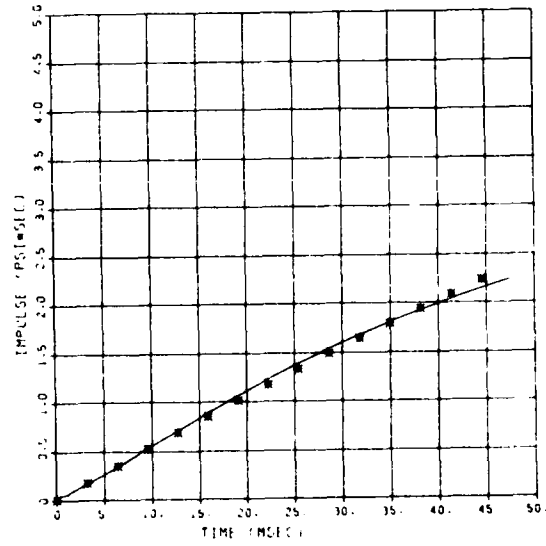
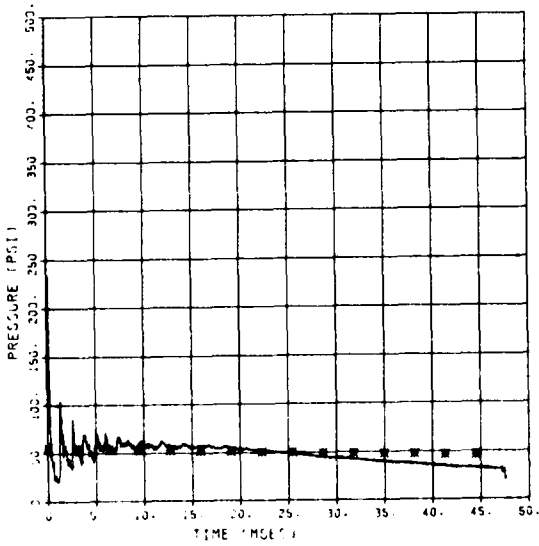

AVERAGE

AVERAGE

**Appendix D**  
**OAK RIDGE NATIONAL LABORATORY CLOSURES**

## 1.1 Description of Test Specimens

In conjunction with the steel Keyworker Shelter Test Program four alternate blast closure designs for the shelter were tested by WES. The closures were designed and constructed by ORNL. Detailed drawings of the closure on the structure's entryway during the full-scale test are shown in Figure D.1. Figure D.2 shows the closure in place during backfilling operations. The closure incurred no damage during the test.

The four alternate designs are referred to as Items 1, 2, 3, and 4. Item 1 was tested on 13 September 1984 in test number 3 of the FEMA Yield Effects test series, which simulated a peak overpressure loading of 128 psi from a 10-KT nuclear weapon. Figure D.3 shows that the closure was a rolled pipe hoop with a stainless steel membrane welded across its upper edge. A 60-inch (inside diameter) corrugated metal culvert skirt was used to help support the blast load. The closure was attached to a 5-foot by 5-foot by 1/2-inch steel frame and was placed on a short length of 36-inch-diameter culvert to simulate an entryway. Figure D.4 shows the location of the closure within the HEST test bed, and Figure D.5 shows the 36-inch-diameter culvert in position. Placement of the closure on the culvert and skirt is shown in Figure D.6.

Item 2 consisted of a rectangular hoop with a 1/8-inch-thick carbon steel plate membrane (Figure D.7). The closure was tested during a calibration test used to design the charge cavity for the full-scale shelter test. The calibration test simulated a 61-psi peak overpressure loading from a 1.3-KT nuclear detonation. The location of the closure in the testbed is shown in Figure D.8. Item 2 was attached to a 5-foot by 5-foot by 1/2-inch steel frame and placed on a short length of 36-inch-diameter steel culvert without a skirt. ORNL referred to this closure as a "yielding membrane."

Items 3 and 4 were tested simultaneously with the full-scale shelter. Figures D.9 and D.10 show details of Items 3 and 4, respectively. The location of the closures in the test bed are shown in Figure D.11. Item 3 was a retest of Item 2 with the addition of a 60-inch-diameter culvert as a skirt. Item 4 was also the "yielding membrane" design. It was attached to a previously tested and slightly deformed frame (from the Item 1 test) without a skirt.

## 1.2 Test Results

The permanent deflections and deformations of the test items are tabulated below. Posttest photographs of the closures are shown in Figures D.12 through D.15.

<i>Test Item</i>	<i>Permanent Center Deflection, inches</i>	<i>Change in Diameter, inches</i>	<i>Deformation of Frame, inches</i>
1	4-3/4	1/2	1/2
2	2-1/2	3/8	0
3	2-1/2	3/8	0
4	1-1/2	1/4	No additional deformation

## 1.3 Conclusions and Recommendations

The simulated weapon yields for the closure tests varied from approximately 1 KT for Item 2 to approximately 1 MT for Items 3 and 4. However, these high-frequency closures are more sensitive to peak overpressure than to yield; therefore, the test results are comparable.

None of the closures ruptured. The "yielding membrane" design (1/8-inch-thick carbon steel) is adequate for withstanding the 50-psi peak overpressure level from a 1-MT nuclear weapon. The tests showed that the use of a 60-inch-diameter culvert skirt beneath the closure is not necessary. The yielding membrane design is recommended for the galvanized steel Keyworker blast shelter.

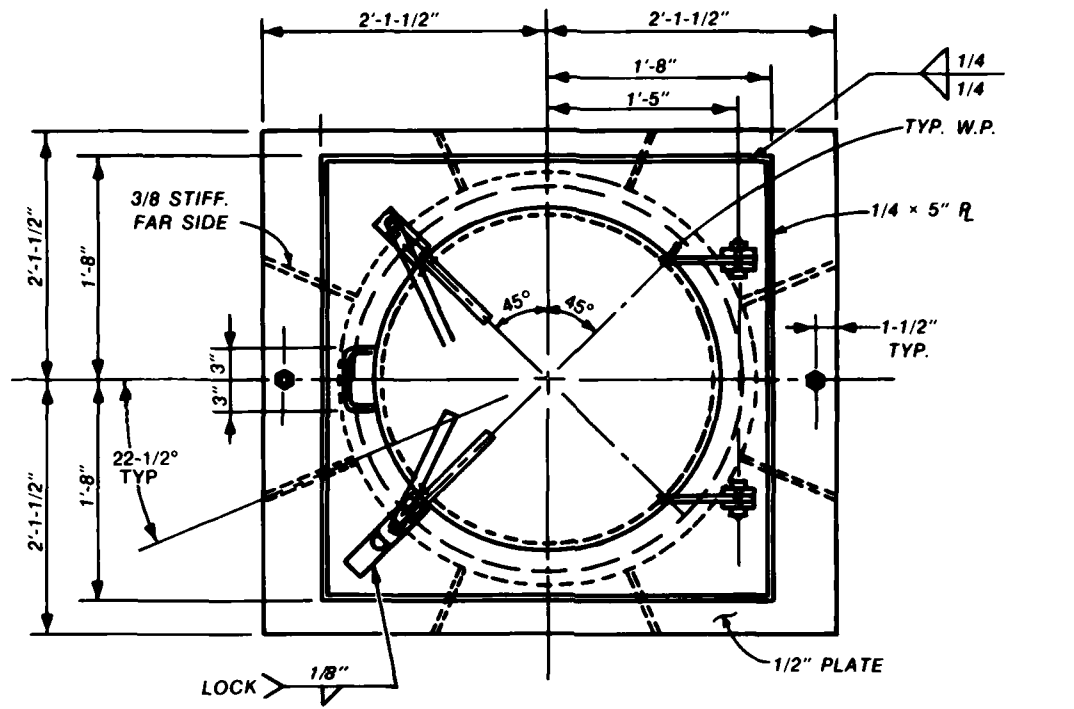

**PLAN**

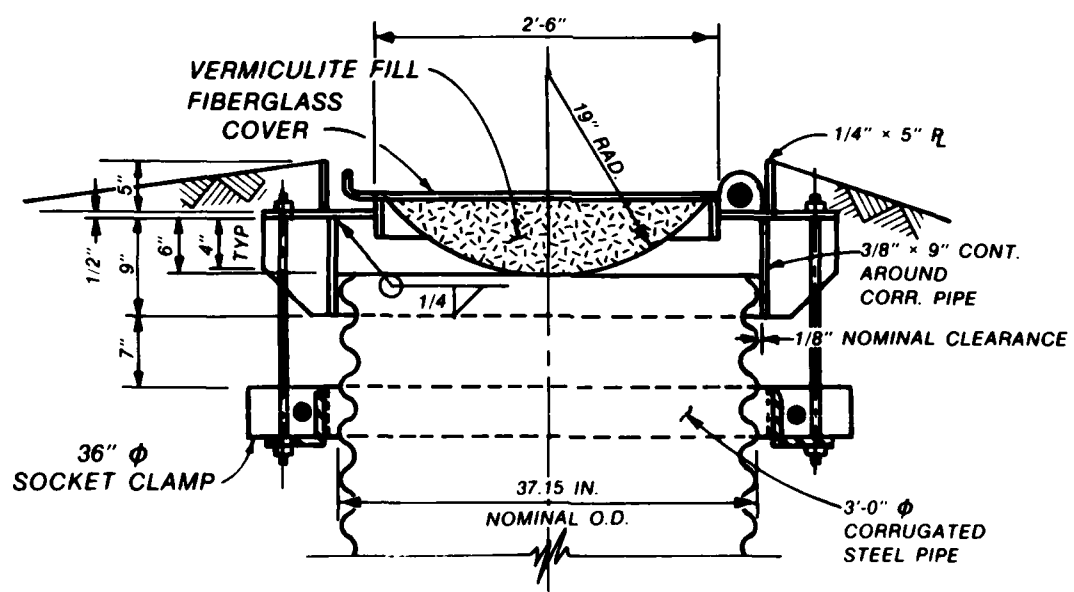

**ELEVATION**

Figure D.1. Closure tested on structure.

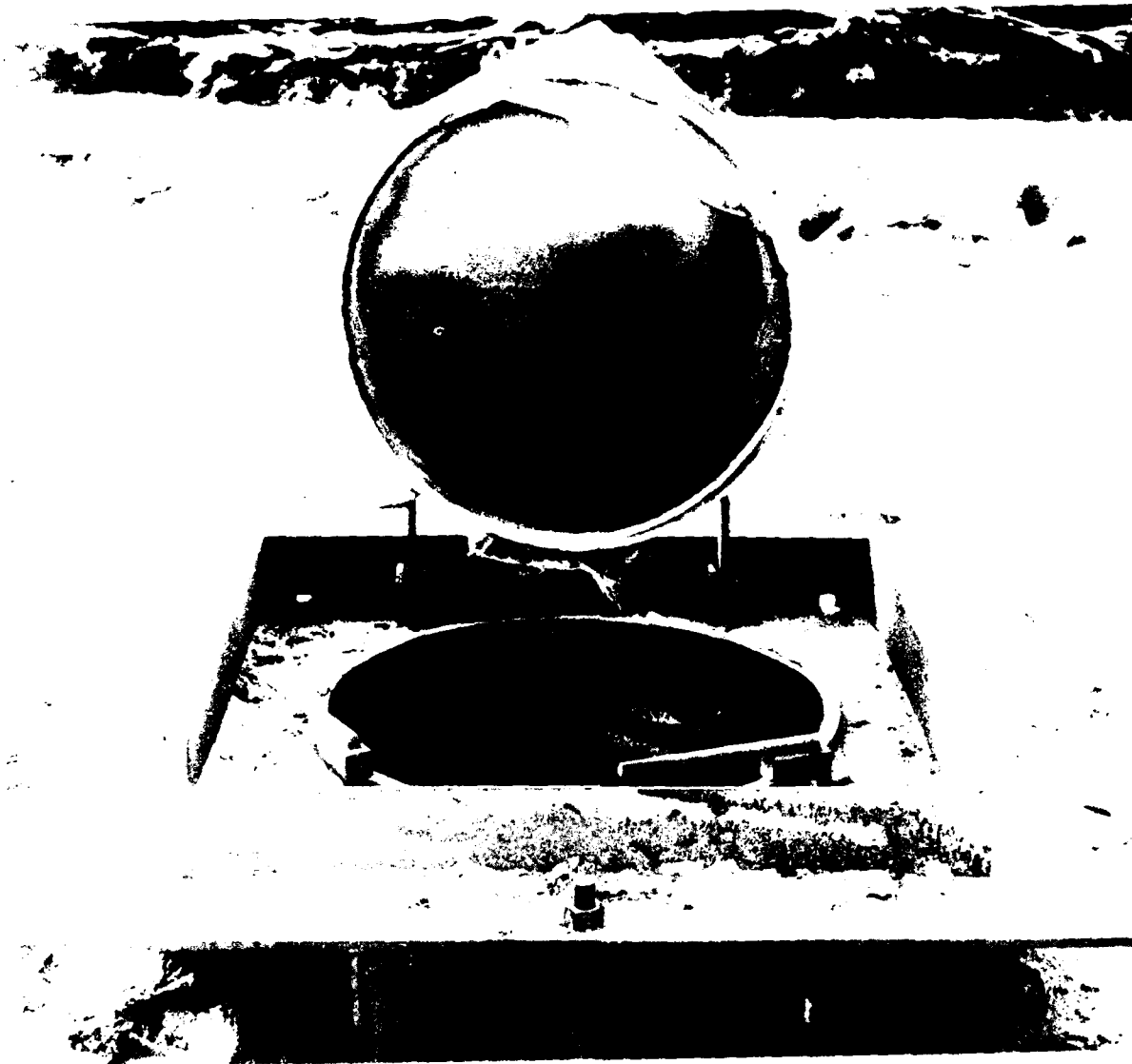
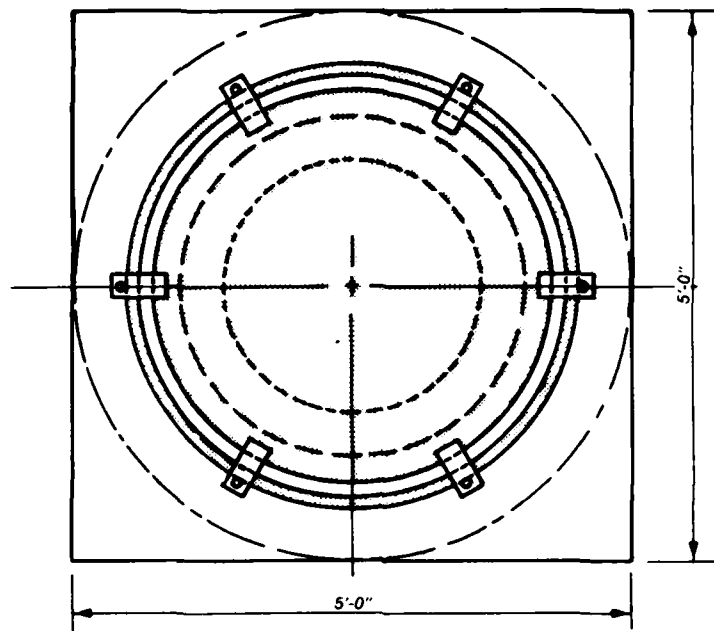
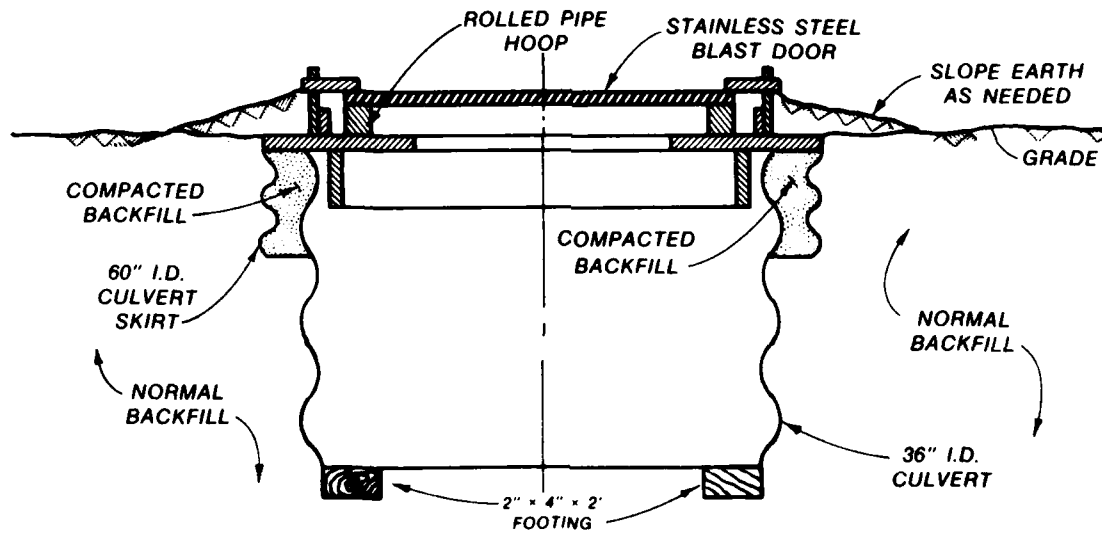

Figure D.2. Closure on entryway of shelter.



**PLAN VIEW**



**ELEVATION VIEW**

**Figure D.3. Item 1.**

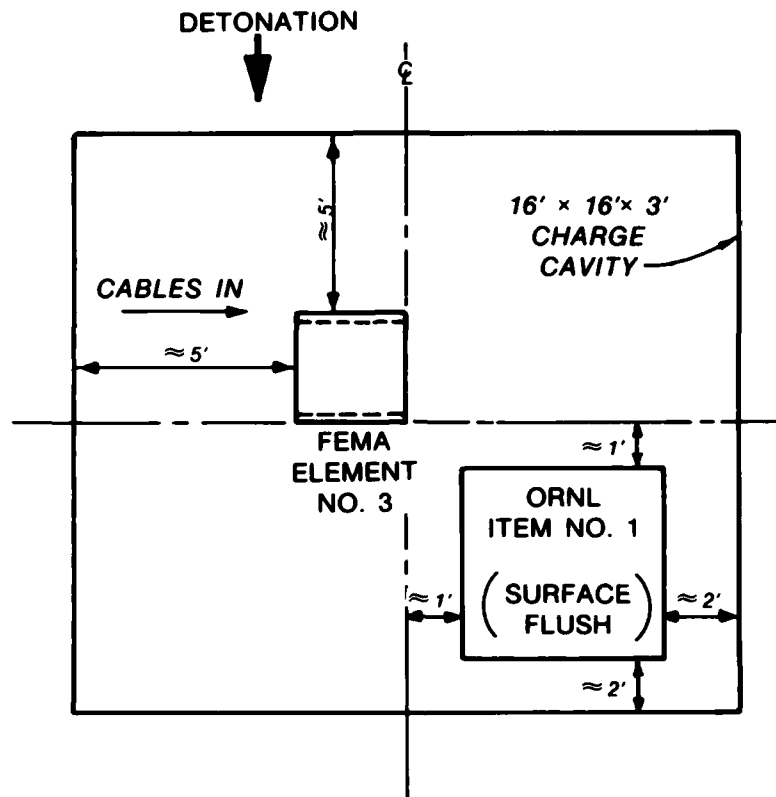

Figure D.4. Item 1 in test bed.



Figure D.5. Item 1 test bed.



Figure D.6. Placement of Item 1 on simulated entryway.

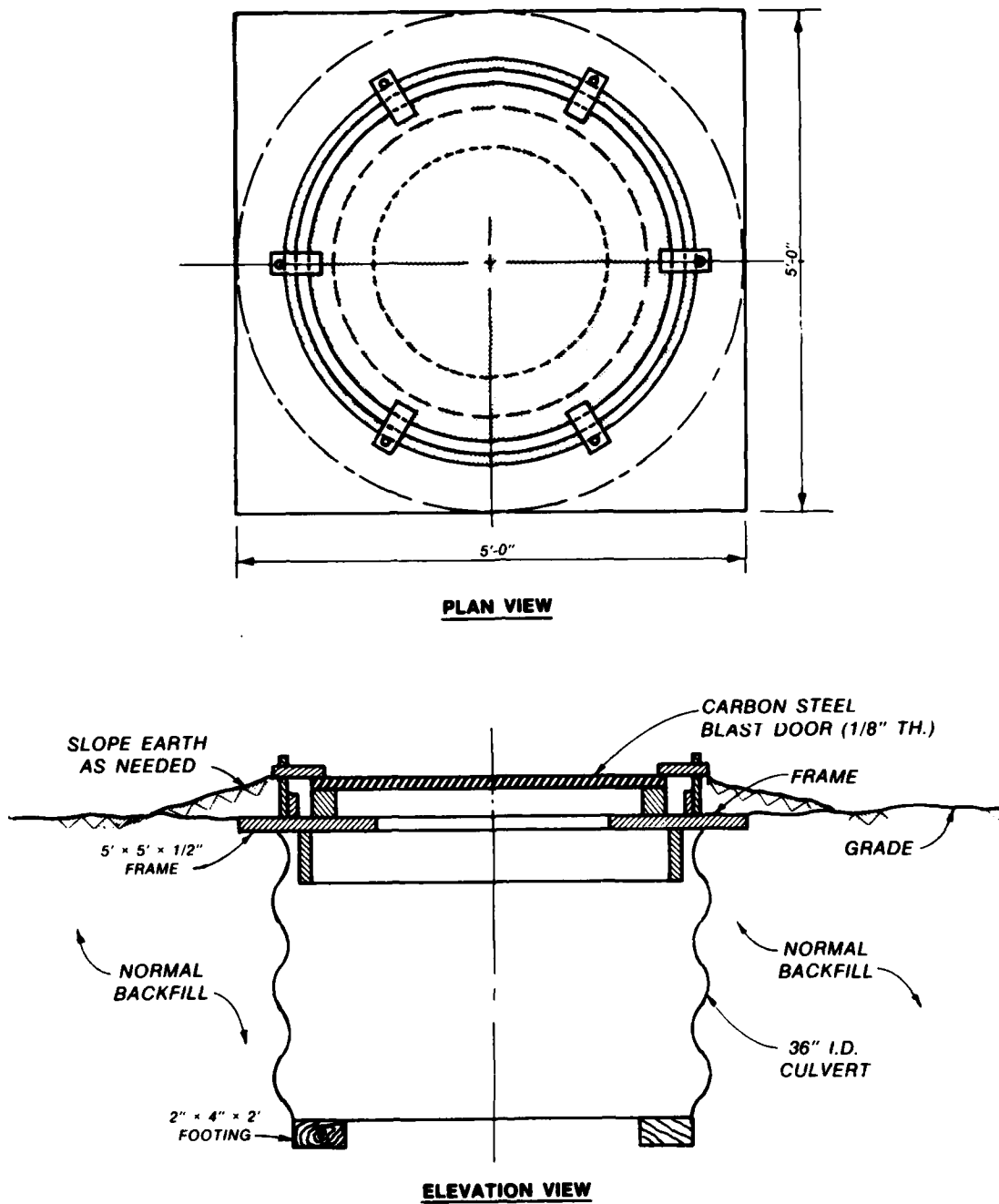

Figure D.7. Item 2.

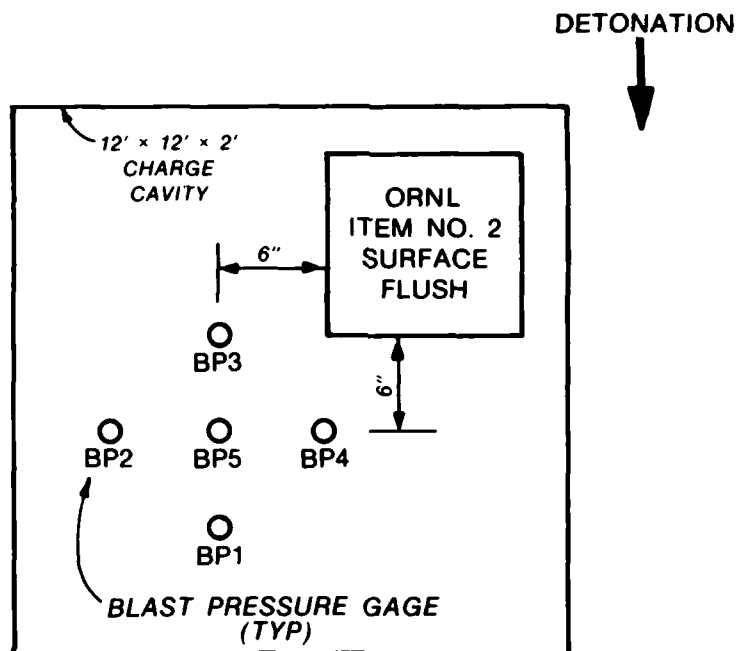
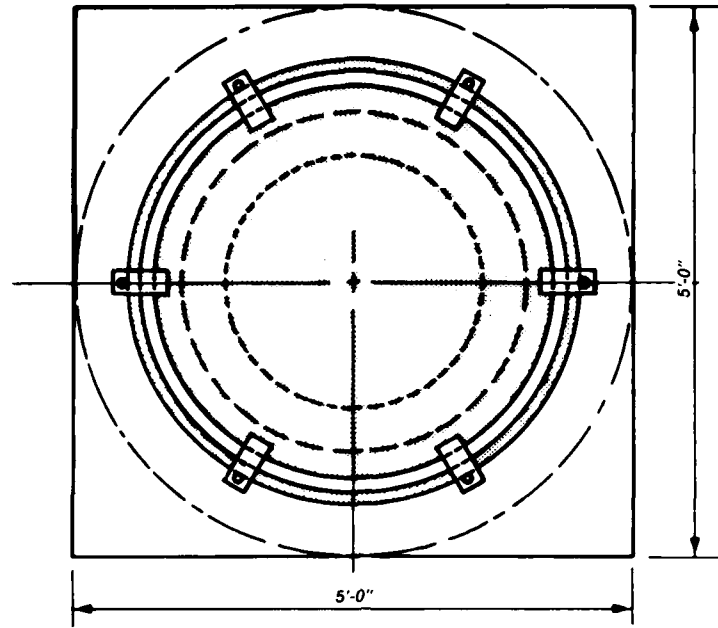
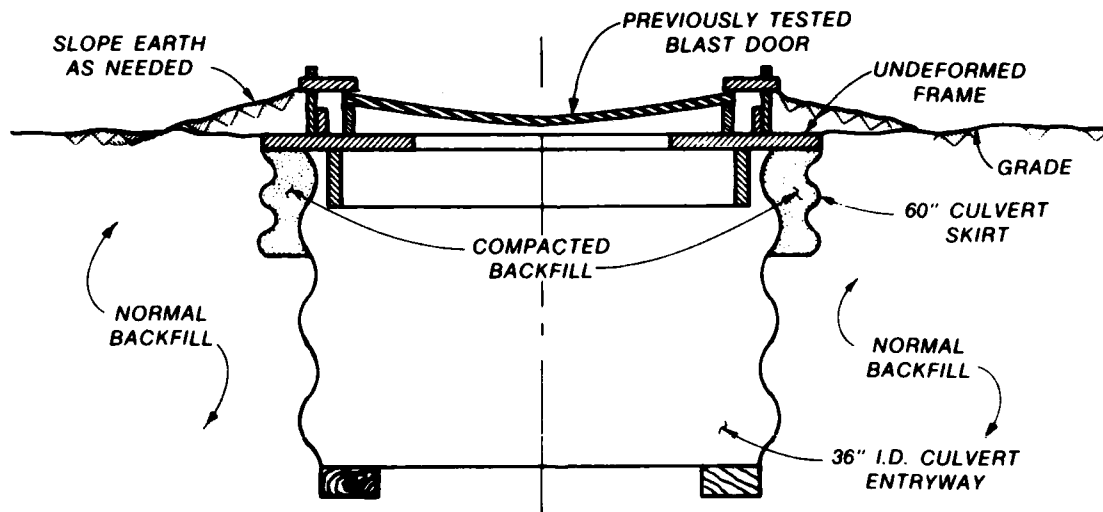

Figure D.8. Item 2 in test bed.



**PLAN VIEW**



**ELEVATION VIEW**

**Figure D.9. Item 3.**

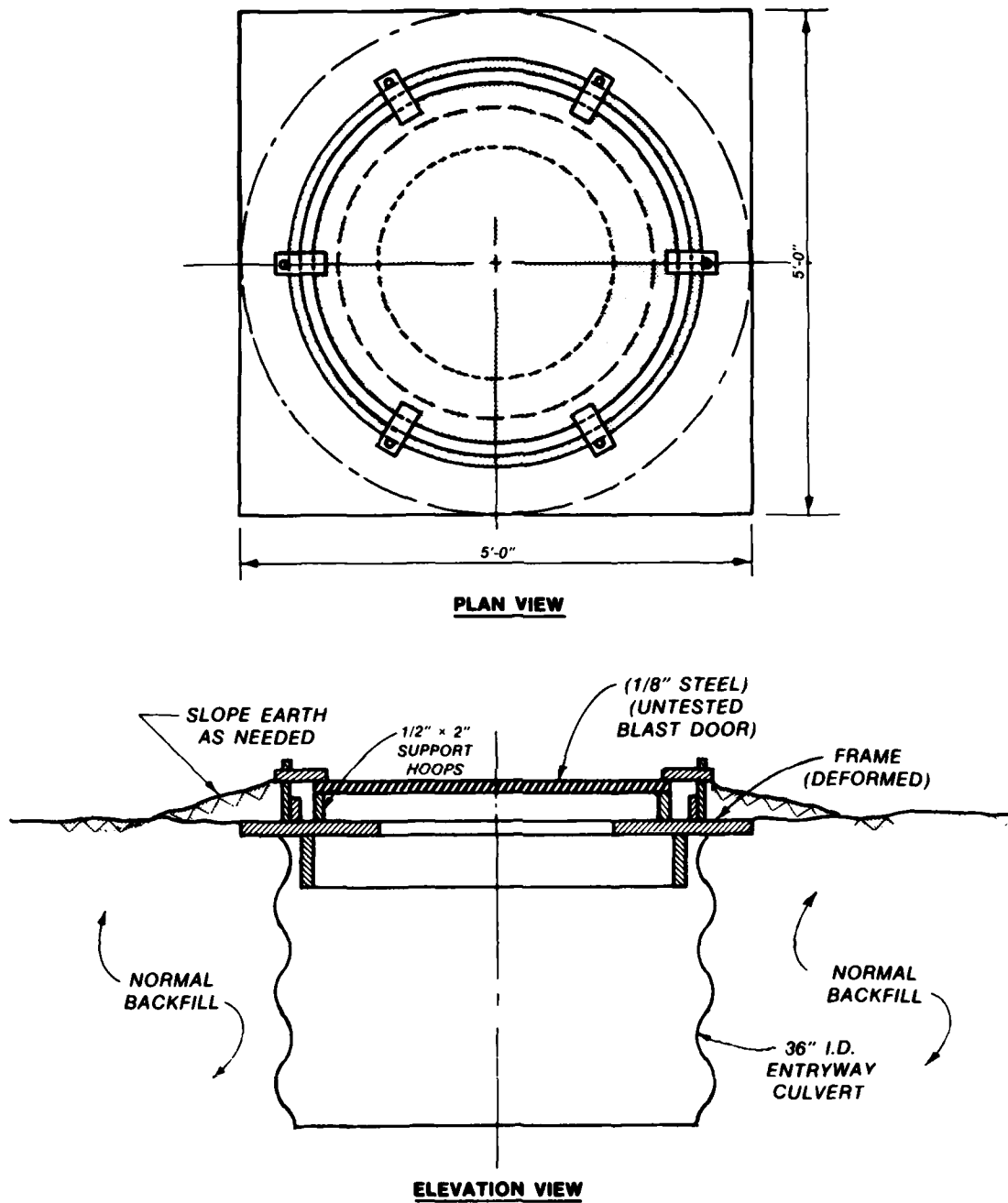

Figure D.10. Item 4.

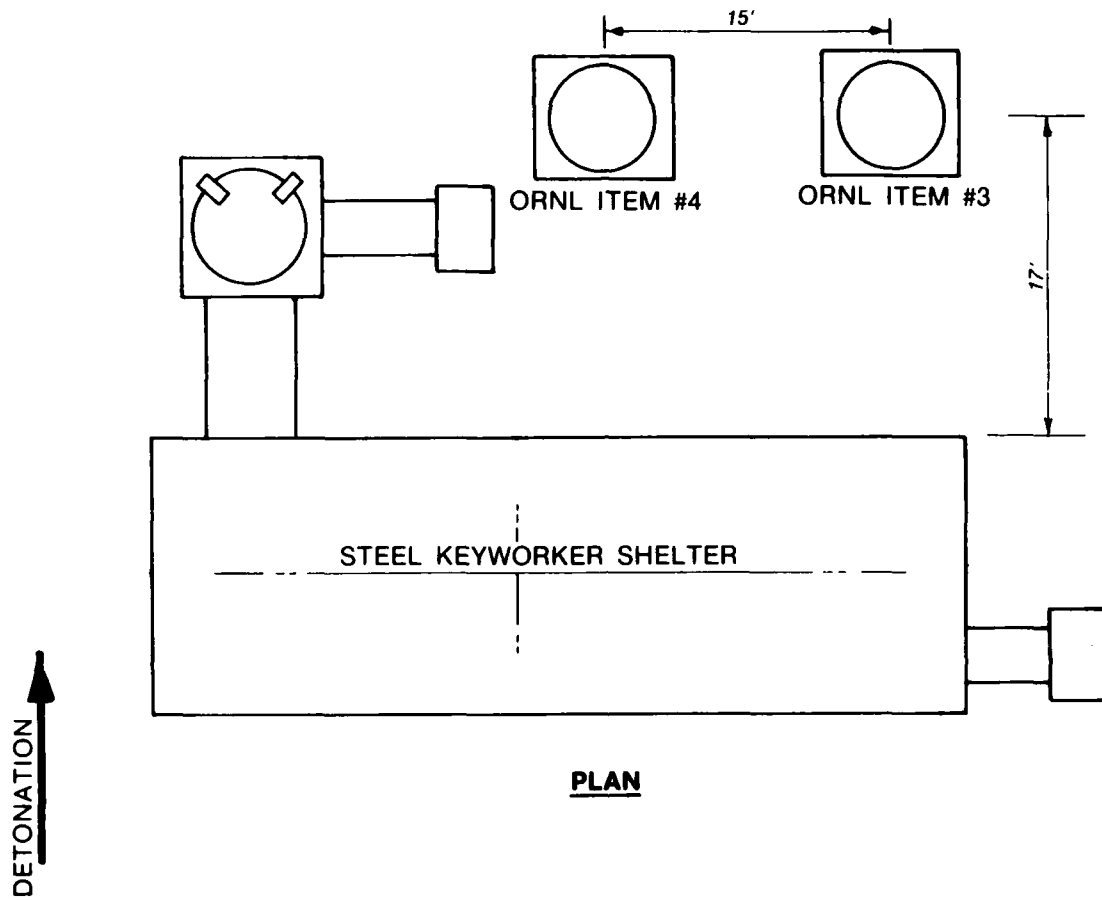

Figure D.11. Items 3 and 4 in test bed.

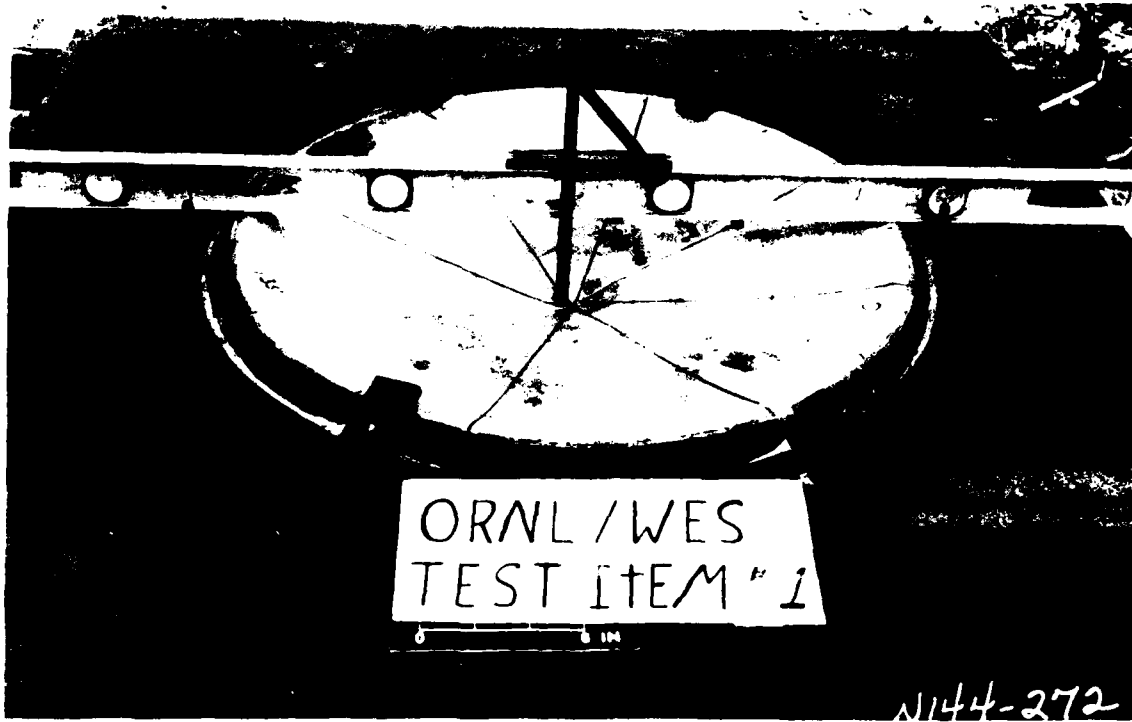

Figure D.12. Posttest view of Item 1.

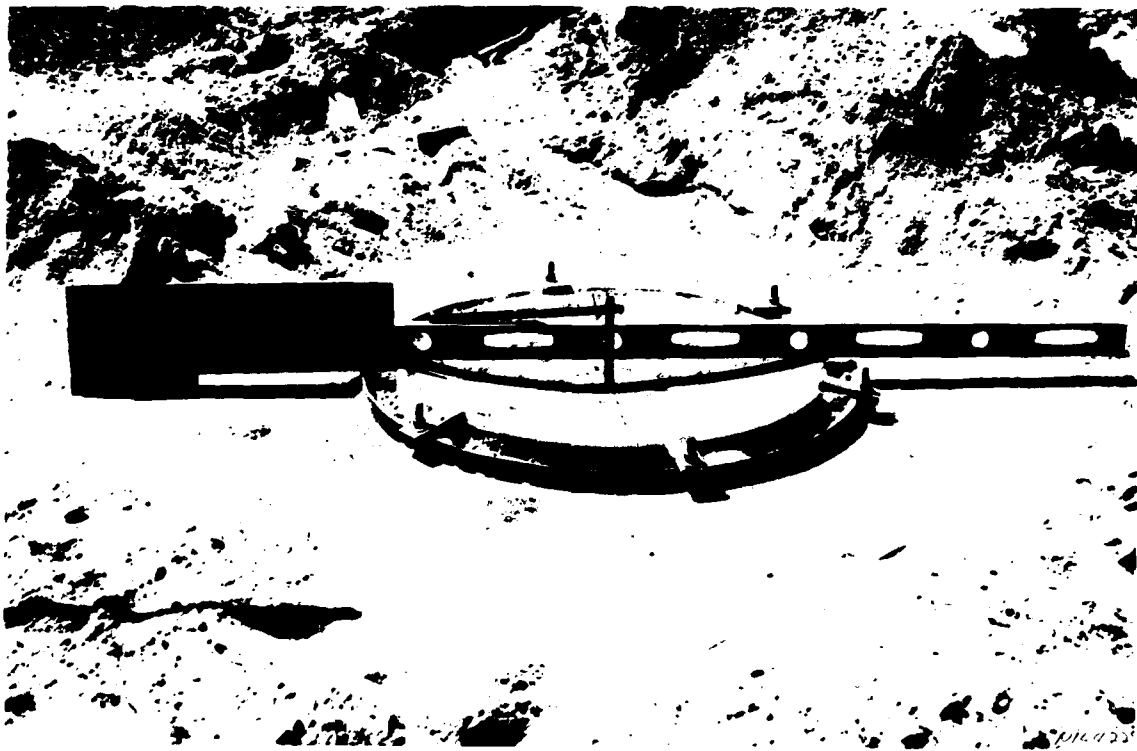

Figure D.13. Posttest view of Item 2.

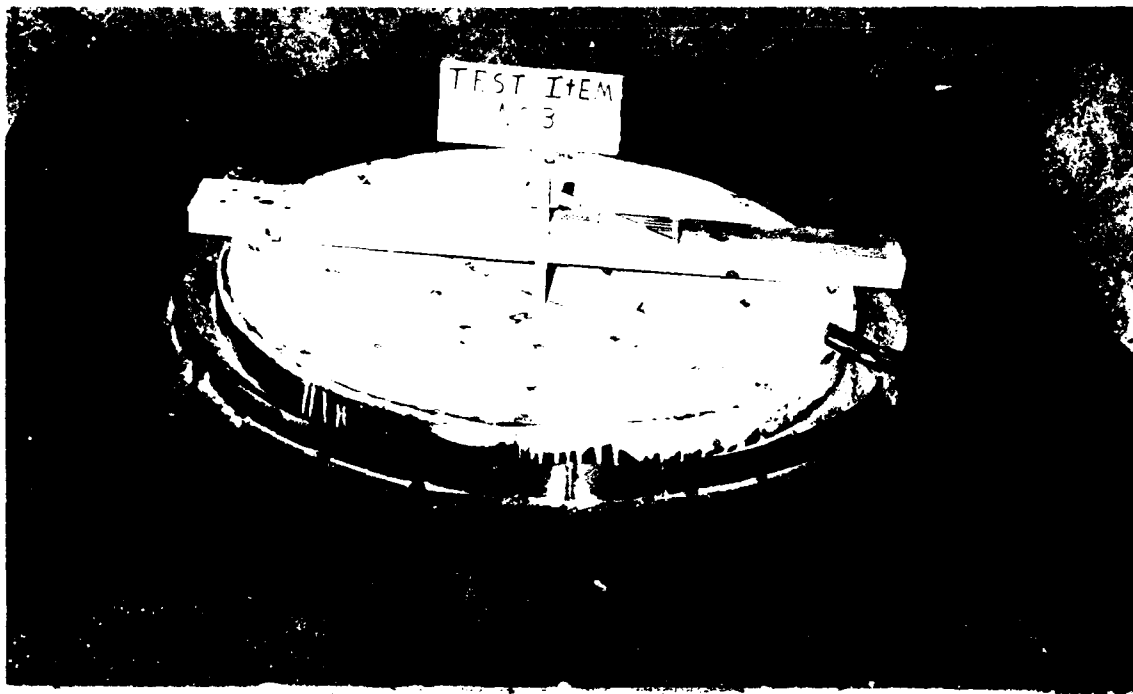

Figure D.14. Posttest view of Item 3.

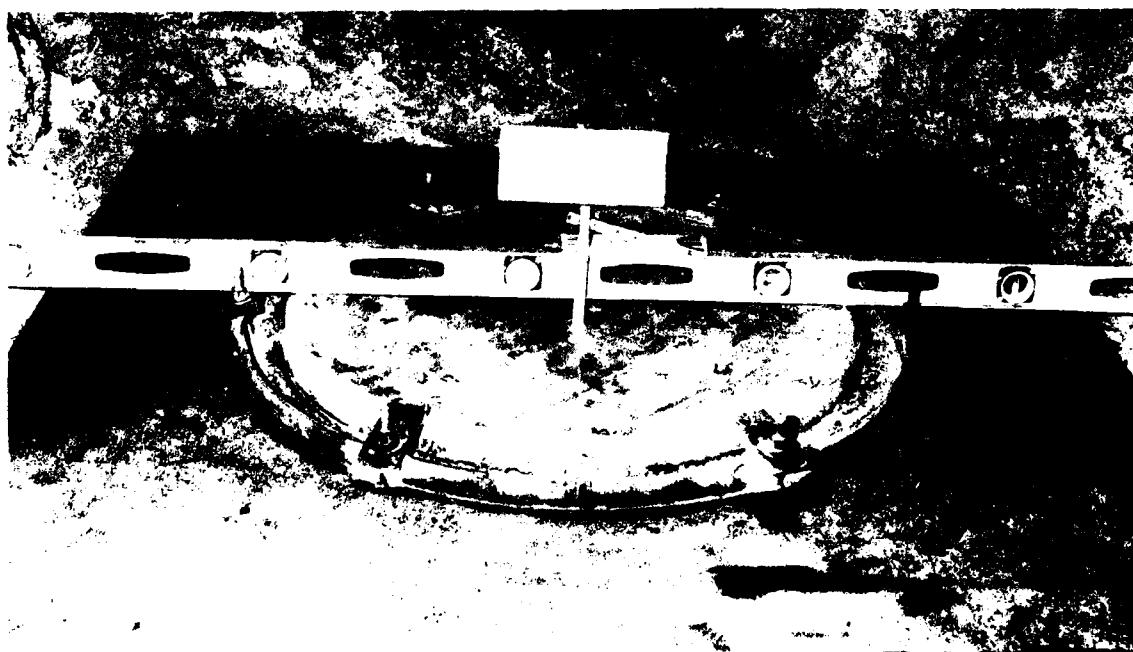

Figure D.15. Posttest view of Item 4.

## DISTRIBUTION LIST

Director, Federal Emergency Management Agency  
ATTN: Mr. Tom Provenzano (6 Cys)  
500 C St. SW  
Washington, DC 20472

Commander, US Army Engineer District, Wilmington  
ATTN: Pat Burns/Library  
PO Box 1890  
Wilmington, N. C. 28402

Headquarters, Department of Energy  
ATTN: Library/G-049 MA-232.2/GTN  
Washington, DC 20545

National Bureau of Standards  
ATTN: Mr. Samuel Kramer  
Dr. Lewis V. Spencer  
Washington, DC 20234

Associate Director, Natural Resources and  
Commercial Services  
Office of Science & Technology  
ATTN: Mr. Phillip M. Smith  
Executive Office Building  
Washington, DC 20500

Director, Office of Administration  
Program Planning and Control  
Department of Housing and Urban Development  
ATTN: Mr. Bert Greenglass  
Washington, DC 20410

Director, Defense Nuclear Agency  
ATTN: SPTD/Mr. Tom Kennedy  
STTL/Technical Library  
Washington, DC 20305

Director, Defense Intelligence Agency  
ATTN: Mr. Carl Wiehle (DB-4C2)  
Washington, DC 20301

Assistant Secretary of the Army (R&D)  
ATTN: Assistant for Research  
Washington, DC 20301

Office, Chief of Engineers,  
Department of the Army  
ATTN: DAEN-RDZ-A  
DAEN-ECE-D  
Washington, DC 20314

Sandia Corporation  
ATTN: Dr. Clarence R. Mehl  
Dept. 5230  
Box 5800, Sandia Base  
Albuquerque, N. Mex. 87115

Director, US Army Engineer Waterways  
Experiment Station  
ATTN: Dr. S. A. Kiger  
Mr. Bill Huff  
Mr. Stan Woodson  
Library  
3 cys  
P. O. Box 631  
Vicksburg, Miss. 39180

Defense Technical Information Center  
12 cy ATTN: (DTIC-DDAB/Mr. Myer B. Kahn)  
Cameron Station  
Alexandria, Va. 22314

Commander, US Army Materials and Mechanics  
Research Center  
ATTN: Technical Library  
Watertown, Mass. 02172

Command and Control Technical Center  
Department of Defense  
Room 2E312 Pentagon  
Washington, DC 20301

Los Alamos Scientific Laboratory  
ATTN: Report Library MS-364  
PO Box 1663  
Los Alamos, N. Mex. 87544

Director, Ballistic Research Laboratory  
ATTN: (DRKBR-TBD/Mr. George Coulter)  
Aberdeen Proving Ground, Md. 21005

Commanding Officer, Office of Naval Research  
Department of the Navy  
Washington, DC 20390

Commanding Officer  
US Naval Civil Engineering Laboratory  
Naval Construction Battalion Center  
ATTN: Library (Code L08A)  
Port Hueneme, Calif. 93043

Commander, Air Force Weapons Laboratory/SUL  
ATTN: Technical Library  
Kirtland Air Force Base, N. Mex. 87117

Civil Engineering Center  
AF/PRECET  
Tyndall AFB, Fla. 32403

University of Florida  
Civil Defense Technical Services  
College of Engineering  
Department of Engineering  
Gainesville, Fla. 32601

Technical Reports Library  
Kurt F. Wendt Library  
College of Engineering  
University of Wisconsin  
Madison, Wisc. 53706

Agbabian Associates  
250 N. Nash Street  
El Segundo, Calif. 90245

AT&T Bell Laboratories  
ATTN: Mr. E. Witt  
Whippany, N. J. 07981

James E. Beck & Associates  
4216 Los Palos Avenue  
Palo Alto, Calif. 94306

Chamberlain Manufacturing Corp.  
GARD, Inc.  
7449 N. Natchez Avenue  
Niles, Ill. 60648

ITT Research Institute  
ATTN: Mr. A. Longinow  
10 West 35th Street  
Chicago, Ill. 60616

H. L. Murphy Associates  
Box 1727  
San Mateo, Calif. 94401

RAND Corporation  
ATTN: Document Library  
1700 Main Street  
Santa Monica, Calif. 90401

Research Triangle Institute  
ATTN: Mr. Edward L. Hill  
PO Box 12194  
Research Triangle P. k., N. C. 27709

Scientific Services, Inc.  
517 East Bayshore Drive  
Redwood City, Calif. 94060

US Army Engineer Division, Huntsville  
ATTN: Mr. Paul Lahoud (10 cys)  
PO Box 1600, West Station  
Huntsville, AL 35807

**DYNAMIC TEST OF A CORRUGATED STEEL KEYWORKER BLAST SHELTER.** Unclassified, US Army Engineer Waterways Experiment Station, May 1986, 79 pp.

At the time this study was initiated, civil defense planning in the United States called for the evacuation of nonessential personnel to safe host areas when a nuclear attack is probable, requiring the construction of blast shelters to protect the key workers remaining in the risk areas. A full-scale corrugated steel keyworker blast shelter was dynamically tested using the High Explosive Simulation Technique (HEST). The test primarily investigated the structural design of the shelter and entryway, survivability of the air-moving system components (generator, blower, and intake and exhaust systems), and occupant survivability. Alternate blast closure designs for the 18-man shelter were also tested.

The test showed that the structure can withstand a 55-psi peak overpressure loading from a 1-MT nuclear detonation with only minor damage. Permanent diameter changes of the 9-foot-diameter shelter were approximately 0.6 to 0.8 inch. Rigid-body displacements were limited to less than 0.5 inch. A high-speed movie camera monitored the movement of three instrumented mannequins, and analysis of the film indicated that impact injuries of occupants are not probable. Also, shock spectra based on acceleration data recorded during the test show that in-structure shock is within acceptable limits for occupants. Typical floor-mounted shelter equipment (generators and communication devices) should be isolated on pads to ensure survivability.

**DYNAMIC TEST OF A CORRUGATED STEEL KEYWORKER BLAST SHELTER.** Unclassified, US Army Engineer Waterways Experiment Station, May 1986, 79 pp.

At the time this study was initiated, civil defense planning in the United States called for the evacuation of nonessential personnel to safe host areas when a nuclear attack is probable, requiring the construction of blast shelters to protect the key workers remaining in the risk areas. A full-scale corrugated steel keyworker blast shelter was dynamically tested using the High Explosive Simulation Technique (HEST). The test primarily investigated the structural design of the shelter and entryway, survivability of the air-moving system components (generator, blower, and intake and exhaust systems), and occupant survivability. Alternate blast closure designs for the 18-man shelter were also tested.

The test showed that the structure can withstand a 55-psi peak overpressure loading from a 1-MT nuclear detonation with only minor damage. Permanent diameter changes of the 9-foot-diameter shelter were approximately 0.6 to 0.8 inch. Rigid-body displacements were limited to less than 0.5 inch. A high-speed movie camera monitored the movement of three instrumented mannequins, and analysis of the film indicated that impact injuries of occupants are not probable. Also, shock spectra based on acceleration data recorded during the test show that in-structure shock is within acceptable limits for occupants. Typical floor-mounted shelter equipment (generators and communication devices) should be isolated on pads to ensure survivability.

**DYNAMIC TEST OF A CORRUGATED STEEL KEYWORKER BLAST SHELTER.** Unclassified, US Army Engineer Waterways Experiment Station, May 1986, 79 pp.

At the time this study was initiated, civil defense planning in the United States called for the evacuation of nonessential personnel to safe host areas when a nuclear attack is probable, requiring the construction of blast shelters to protect the key workers remaining in the risk areas. A full-scale corrugated steel keyworker blast shelter was dynamically tested using the High Explosive Simulation Technique (HEST). The test primarily investigated the structural design of the shelter and entryway, survivability of the air-moving system components (generator, blower, and intake and exhaust systems), and occupant survivability. Alternate blast closure designs for the 18-man shelter were also tested.

The test showed that the structure can withstand a 55-psi peak overpressure loading from a 1-MT nuclear detonation with only minor damage. Permanent diameter changes of the 9-foot-diameter shelter were approximately 0.6 to 0.8 inch. Rigid-body displacements were limited to less than 0.5 inch. A high-speed movie camera monitored the movement of three instrumented mannequins, and analysis of the film indicated that impact injuries of occupants are not probable. Also, shock spectra based on acceleration data recorded during the test show that in-structure shock is within acceptable limits for occupants. Typical floor-mounted shelter equipment (generators and communication devices) should be isolated on pads to ensure survivability.

**DYNAMIC TEST OF A CORRUGATED STEEL KEYWORKER BLAST SHELTER.** Unclassified, US Army Engineer Waterways Experiment Station, May 1986, 79 pp.

At the time this study was initiated, civil defense planning in the United States called for the evacuation of nonessential personnel to safe host areas when a nuclear attack is probable, requiring the construction of blast shelters to protect the key workers remaining in the risk areas. A full-scale corrugated steel keyworker blast shelter was dynamically tested using the High Explosive Simulation Technique (HEST). The test primarily investigated the structural design of the shelter and entryway, survivability of the air-moving system components (generator, blower, and intake and exhaust systems), and occupant survivability. Alternate blast closure designs for the 18-man shelter were also tested.

The test showed that the structure can withstand a 55-psi peak overpressure loading from a 1-MT nuclear detonation with only minor damage. Permanent diameter changes of the 9-foot-diameter shelter were approximately 0.6 to 0.8 inch. Rigid-body displacements were limited to less than 0.5 inch. A high-speed movie camera monitored the movement of three instrumented mannequins, and analysis of the film indicated that impact injuries of occupants are not probable. Also, shock spectra based on acceleration data recorded during the test show that in-structure shock is within acceptable limits for occupants. Typical floor-mounted shelter equipment (generators and communication devices) should be isolated on pads to ensure survivability.

END

DATE

7-86