

Resolution Test Chart

AD-A168 791

IDA PAPER P-1882

C<sup>3</sup> EVAL MODEL DEVELOPMENT AND TEST  
Volume I: Overview

Robert F. Robinson  
Joseph W. Stahl  
M. L. Roberson  
*Applications Research Corporation*

October 1985

OTIC FILE COPY

*Prepared for*  
Joint Chiefs of Staff



INSTITUTE FOR DEFENSE ANALYSES  
1801 N. Beauregard Street, Alexandria, Virginia 22311

AD-A168 791

1a. REPORT SECURITY CLASSIFICATION UNCLASSIFIED				3. DISTRIBUTION/AVAILABILITY OF REPORT Approved for public release; distribution unlimited			
2a. SECURITY CLASSIFICATION AUTHORITY DD Form 254 dated 1 October 1983				5. MONITORING ORGANIZATION REPORT NUMBER (S)			
2b. DECLASSIFICATION/DOWNGRADING SCHEDULE N/A							
4. PERFORMING ORGANIZATION REPORT NUMBER (S) IDA Paper P-1882				7a. NAME OF MONITORING ORGANIZATION OUSDRE (DoD-IDA Management Office)			
6a. NAME OF PERFORMING ORGANIZATION Institute for Defense Analyses		6b. OFFICE SYMBOL (If applicable)		7b. ADDRESS (CITY, STATE, ANMD ZIP CODE) 1801 North Beauregard Street Alexandria, VA 22311			
6c. ADDRESS (City, State, and Zip Code) 1801 N. Beauregard Street Alexandria, VA 22311				9. PROCUREMENT INSTRUMENT IDENTIFICATION NUMBER MDA 903 84 C 0031			
8a. NAME OF FUNDING/SPONSORING ORGANIZATION Joint Chiefs of Staff (J-5)		8b. OFFICE SYMBOL (If applicable)		10. SOURCE OF FUNDING NUMBERS			
8c. ADDRESS (City, State, and Zip Code) The Pentagon Washington, D.C. 20301-5000							
				PROGRAM ELEMENT	PROJECT NO.	TASK NO. T-5-308	ACCESSION NO. WORK UNIT
11. TITLE (Include Security Classification) C <sup>3</sup> EVAL MODEL DEVELOPMENT AND TEST - Volume 1 - Overview							
12. PERSONAL AUTHOR (S) Robert F. Robinson, Joseph W. Stahl, M.L. Roberson (ARC)							
13. TYPE OF REPORT FINAL		13b. TIME COVERED FROM _____ TO _____		14. DATE OF REPORT (Year, Month, Day) 1985, October		15. PAGE COUNT 83	
16. SUPPLEMENTARY NOTATION							
17. COSATI CODES			18. SUBJECT TERMS (Continue on reverse if necessary and identify by block number) Command, Control, communications combat assessment, methodology, simulation, games, analysis, effectiveness, measures				
FIELD	GROUP	SUB-GROUP					
19. ABSTRACT (Continue on reverse if necessary and identify by block number)  This is an interim report on the extension and development of the C <sup>3</sup> EVAL model. The model is to permit assessment of the effects on combat of changes in command and control processes and communications network structure and capacity. The model has had a partial pre-processor added to assist possible analyst/model users to input data and a post-processor to provide graphic display of some outputs. The command structure includes the Central European command nodes from division to SHAPE for U.S. forces. The nodes have had input and output limits added to permit representation of degraded operation as under attack or when the unit is moving. The corps level force allocation procedure has been improved. Some processes have been randomized. The corps operates on information different from that available at the division or combat unit due to time delays, randomness, and scenario inputs. The impact of changes in the C <sup>3</sup> system can be seen in changes in weapon losses, non-arrival of close air support, and messages delays/lost as well as other operations related elements.							
20. DISTRIBUTION/AVAILABILITY OF ABSTRACT <input type="checkbox"/> UNCLASSIFIED/UNLIMITED <input checked="" type="checkbox"/> SAME AS RPT. <input type="checkbox"/> DTIC USERS				21. ABSTRACT SECURITY CLASSIFICATION			
22a. NAME OF RESPONSIBLE INDIVIDUAL				22b. TELEPHONE (Include Area Code)		22c. OFFICE SYMBOL	

IDA PAPER P-1882

**C<sup>3</sup> EVAL MODEL DEVELOPMENT AND TEST**  
**Volume I: Overview**

**Robert F. Robinson**  
**Joseph W. Stahl**  
**M. L. Roberson**  
*Applications Research Corporation*

October 1985



**INSTITUTE FOR DEFENSE ANALYSES**

Contract MDA 903 84 C 0031  
Task T-5-309

X

A-1



## TABLE OF CONTENTS

Preface. . . . .	iii
Executive Summary. . . . .	S-1
I. Introduction . . . . .	1
A. Objectives . . . . .	1
B. Background . . . . .	1
C. Approach . . . . .	2
II. C <sup>3</sup> Eval Model . . . . .	4
A. Introduction . . . . .	4
B. General Description. . . . .	4
C. Data Input . . . . .	5
D. Simulation Description . . . . .	6
E. Graphics Post-Processor. . . . .	16
F. Additions and Tests. . . . .	41
a. Communications Network . . . . .	42
b. Node Operations. . . . .	42
c. Time T Input . . . . .	44
d. Output Enhancements. . . . .	44
e. Random Processes . . . . .	44
G. Preprocessor Development . . . . .	45
III. Data . . . . .	47
A. Introduction . . . . .	47
B. Development of Decision Rules for C <sup>3</sup> Eval . . . . .	47
C. Communication Path Capacities. . . . .	51
D. Combat Data. . . . .	60

IV.	Future Development . . . . .	62
A.	Introduction . . . . .	62
B.	Logistics and Nuclear. . . . .	62
C.	Command Node and Scenario Extension. . . . .	64
D.	Additional Modifications . . . . .	66

### FIGURES

Figure II-	I.	Command Structure in Central Europe . . . . .	7
Figure II-	2.	Path Connections With V Corps Tac . . . . .	9
Figure II-	3.	Node Internal Structure . . . . .	11
Figure II-	4.	Summary Graphs for Communications Path Limit . . . . .	20
Figure II-	5.	Time T Graph Communications Path Limit at 23rd Armored Division, Cases 1 and 2 . . . . .	21
Figure II-	6.	Summary Graphs for Input Limit. . . . .	23
Figure II-	7.	Time T Graph for Input Limit at the 23rd Armored Division. . . . .	24
Figure II-	8.	Summary Graph for the Output Limitation Demonstration . . . . .	25
Figure II-	9.	Time T Graphs for the 23rd Armored Division, Output Limit Demonstration. . . . .	26
Figure II-	10.	Summary Graph of Combat Support . . . . .	27
Figure II-	11.	Time T Plots of Combat Support/CAS Sorties. . . . .	28
Figure II-	12a.	Summary Graphs of Losses at the 23rd Armored Division (Base Case) . . . . .	29
Figure II-	12b.	Summary Graphs of Losses at the 23rd Armored Division (Base Case). . . . .	30
Figure II-	13a.	Summary Graphs for Losses at the 23rd Armored Division (Case 2) . . . . .	31
Figure II-	13b.	Summary Graphs for Losses at the 23rd Armored Division (Case 2) . . . . .	32
Figure II-	14a.	Time T Losses for Blue and Red (Base Case) at 23rd Armored Division. . . . .	33
Figure II-	14b.	Time T Losses for Blue and Red (Base Case) at 23rd Armored Division. . . . .	34
Figure II-	14c.	Time T Losses for Blue and Red (Base Case) at 23rd Armored Division. . . . .	35

Figure II-14d.	Time T Losses for Blue and Red (Base Case) at 23rd Armored Division. . . . .	36
Figure II-15a.	Time T Losses for Blue and Red (Case II) at 23rd Armored Division. . . . .	37
Figure II-15b.	Time T Losses for Blue and Red (Case II) at 23rd Armored Division. . . . .	38
Figure II-15c.	Time T Losses for Blue and Red (Case II) at 23rd Armored Division. . . . .	39
Figure II-15d.	Time T Losses for Blue and Red (Case IV) at 23rd Armored Division. . . . .	40
Figure III- 1.	Immediate Request for CAS Node Numbers . . .	49
Figure III- 2.	Rule Numbers and Message Numbers for Immed- iate Request for CAS . . . . .	50
Figure III- 3.	CAS Messages, General Process Title. . . . .	52
Figure III- 4.	Rule Data Form . . . . .	53
Figure III- 5.	Input Messages Required to Initialize. . . .	55
Figure III- 6.	Output Messages Based on Decision Rules. . .	54
Figure III- 7.	Rule Data CAS Messages at Corps. . . . .	56
Figure III- 8.	Input Messages Required to Initialize. . . .	57
Figure III- 9.	Example of Output Messages . . . . .	58

## PREFACE

This effort was undertaken in March 1985 as a part of a continuing program to develop the C3EVAL model as an analytic tool for use by the Office of the Joint Chiefs of Staff/Command Control and Communications Systems (OJCS/C3S) under Contract No. MDA 903-84C-0031, Task Order No. T-5-309. The basic model has been developed by IDA with programming support from Applications Research Corporation (ARC). This work is reported in IDA Paper P-1756, "Development of C3 Assessment Methodology: The C3EVAL Model," dtd February 1984. This is a report on work in progress and provides a description of the work done in FY1985, an update of the users' manual, and a briefing on the model and its current capabilities.

## EXECUTIVE SUMMARY

### A. OBJECTIVE

The objective of this phase of the C<sup>3</sup> EVAL model development program is to "extend the model so that it may be used to display the combat consequences of changes in command and control processes and changes in communications network structure and capacity, where changes result from C<sup>3</sup> deficiencies identified in the periodic OJCS/C<sup>3</sup>S Performance Evaluation." The guidance provided also led to preliminary development of an input processor and graphics support package.

### B. REPORTS

The report on the work accomplished in FY1985 is in three volumes. The first volume contains a general description of the model and of the improvements that have been made. The second volume is a user's/programmer's manual that updates the code and its description. The final volume is a briefing about the model and its capabilities.

The model has been designed to assess C<sup>3</sup> in terms of the impact of changes in C<sup>3</sup> on combat operations. Basic to the concept of the model is the representation of the flow and use of information as represented by explicit, doctrinally specified messages. The messages are created at the nodes representing the command and control units over communications paths. Combat units are in the current structure divisions that can be supported by air forces.

The model is an aggregated model intended for use in JCS evaluations and treats the flow and use of information from division to SHAPE in the Central European command. The node and path structure currently in the model is as shown in Figure S-1. The model is designed to be flexible so that it can be adapted to other command structures and scenarios. This flexibility is achieved by making it possible for the user to select the nodes and paths desired. Once the selection has been made, however, and rules have been chosen for the operation of the nodes, changes can be made made only with considerable care. The level of aggregation is also user chosen and this is reflected in the characteristics of the combat units and the time interval chosen for the operation of the model.

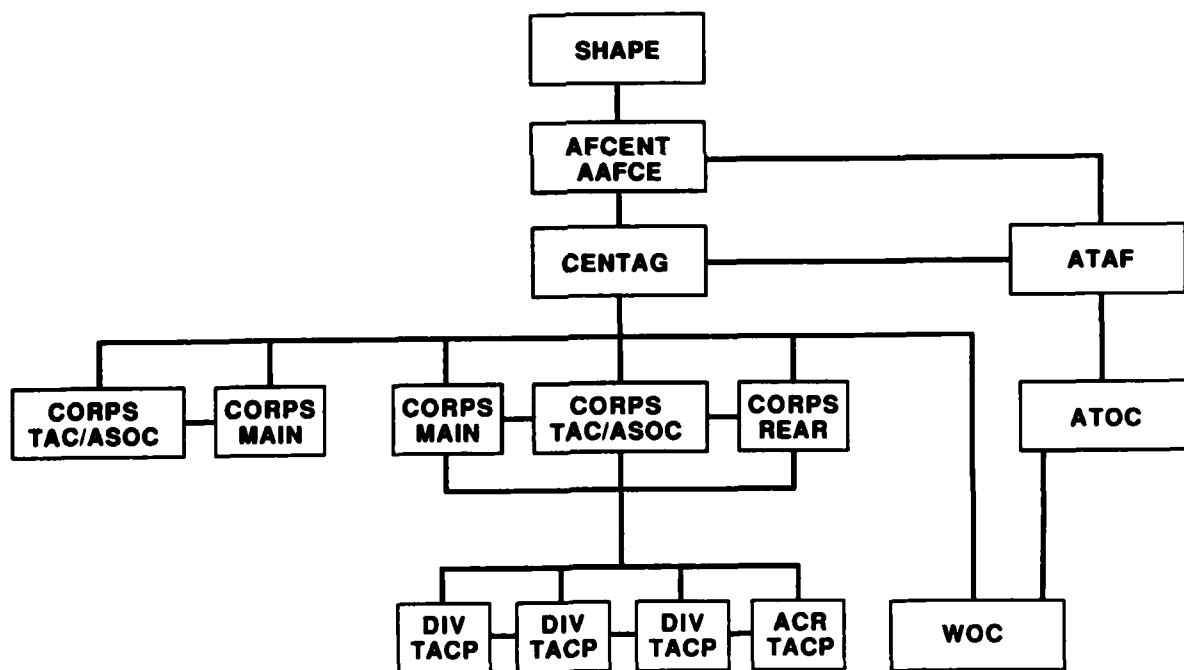

8-30-85-2M  
UNCLASSIFIED

Figure S-1.

The basic node structure is the same for all nodes. The differences in operations of the different units represented by the nodes is accomplished by differences in the user input rules. This basic node structure receives messages from other nodes from the scenario input or from the file of messages held over from previous time intervals. Messages are processed to generate new messages which are sent to the destination files where they are transmitted to the next node depending on priority, designated mode of transmission (e.g., voice, TTY), and the available capacity of the designated communications paths. Alternate modes of transmission will be used if the user has designated in the data that these alternatives are acceptable. Alternate paths through other command nodes can also be used if so designated.

During the FY85 effort, an input limit and an output limit have been added to allow for the representation of reductions in operating capacity that might occur when the unit was moving or had been attacked. The additions included the development of rules for corps that allow for the reallocation of corps controlled combat resources when triggered by request messages from subordinate units. The "decisions" requesting or allocating resources are based on calculation of force ratio at division and corps. Corps information on the Red and Blue forces on which the force ratio calculations are based are determined by messages from division reporting Blue losses and intelligence on Red forces. Scenario input data can also represent intelligence inputs. Randomness is introduced into the division reports of losses of both sides, thus introducing additional verisimilitude.

Communications paths are aggregations of all links between two nodes. The user can assign as many different kinds of paths as desired, e.g., voice, secure voice, and TTY. The user may also designate several types or modes of communication paths. Any communication path will be used only if the messages and rules are written so that the path is designated for use.

During the course of the FY85 effort development was started on a pre-processor to facilitate the data input. The full schedule of data inputs includes

- 1) Node designation with unit type, subordinates, superiors, alternatives, and coordination,
- 2) Node limits (input and output limits),
- 3) Communications paths with types and capacities.
- 4) External messages with scenario inputs,
- 5) Combat data,
- 6) Aircraft data,
- 7) Helicopter data,
- 8) Rules

Of these, the first has been implemented with a data dictionary and instructions to facilitate data input by the user.

Another major addition to C<sup>3</sup>EVAL during the current work is a post-processor for graphic summaries. These may be bar graphs summarizing all specified data over the time period or time-t graphs of the selected topic for each time interval. Output summaries are available from a menu as follows:

- 1) Quit
- 2) Communications Path Limit
- 3) Input Limit
- 4) Output Limit
- 5) Combat Support
- 6) Losses

Examples of the output are given in the following. In the first case used, it is assumed that all nodes are operating at full

capacity, all communications paths are available, and "random" is off. This latter assumption means that the list of user designated external messages that have been "randomized" to represent non-periodic events is not activated. There is no randomization of the loss reports and any other random effects do not appear. The second case, designated on the curves as "Case II," includes considerable disruption in the operation of the C<sup>3</sup> system. The "random" is on and there are additional external messages. There are input and output limits on the messages from the 23rd Armored Division. In addition, there are time designated reductions in the capacity of selected communications paths. The first of the graphics to be shown is Figure S-2, Summary Graphs for Communications Path Limit. This shows the summary of messages sent at V Corps Tac, 52nd Mech and the 23rd Armored Division. Note first that there are many more messages in the system for Case 2 and that for this case there are large numbers of messages held or deleted because of the limits on the capability of the nodes and the capacity of some of the communications paths. If greater detail at one of the nodes is desired, it is possible to obtain the Time T graph at that node. Figure S-3 shows the Time T graph for the Communications Path Limit at the node for the 23rd Armored Division. For Case 2 the communications with that node have been disrupted as described in the scenario.

Figure S-4 shows a plot of combat losses for tanks, AVVs, and APCs for the Red forces attacking the 23rd Armored Division as plotted on a Time-t graph.

During the development of the model there were thorough tests conducted as each change was made. This testing was done to assure that the model was working as intended and that bugs were eliminated. The testing was also conducted on the pre-and post-processors as they were developed.

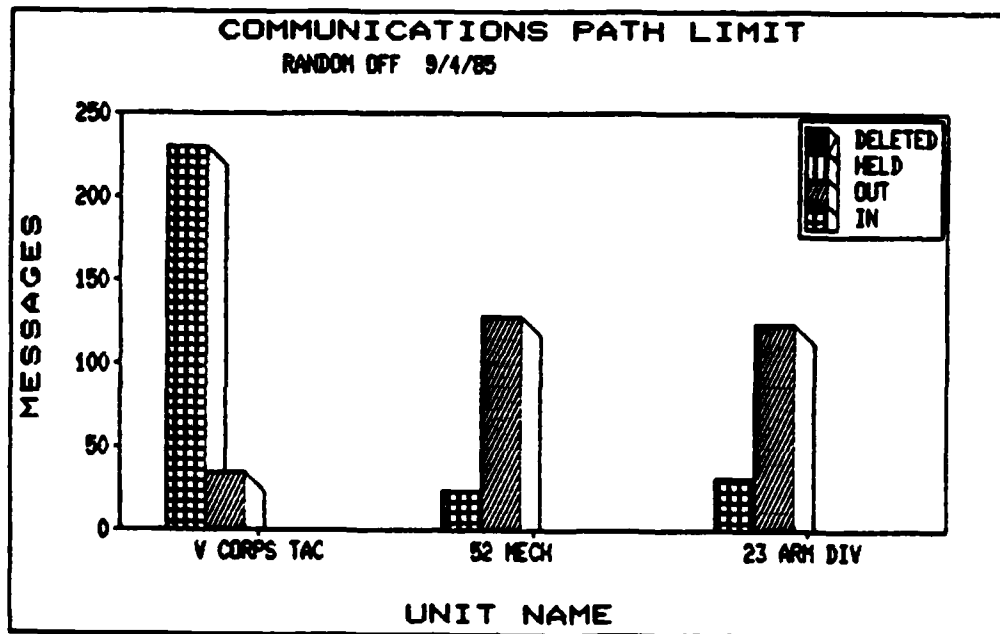
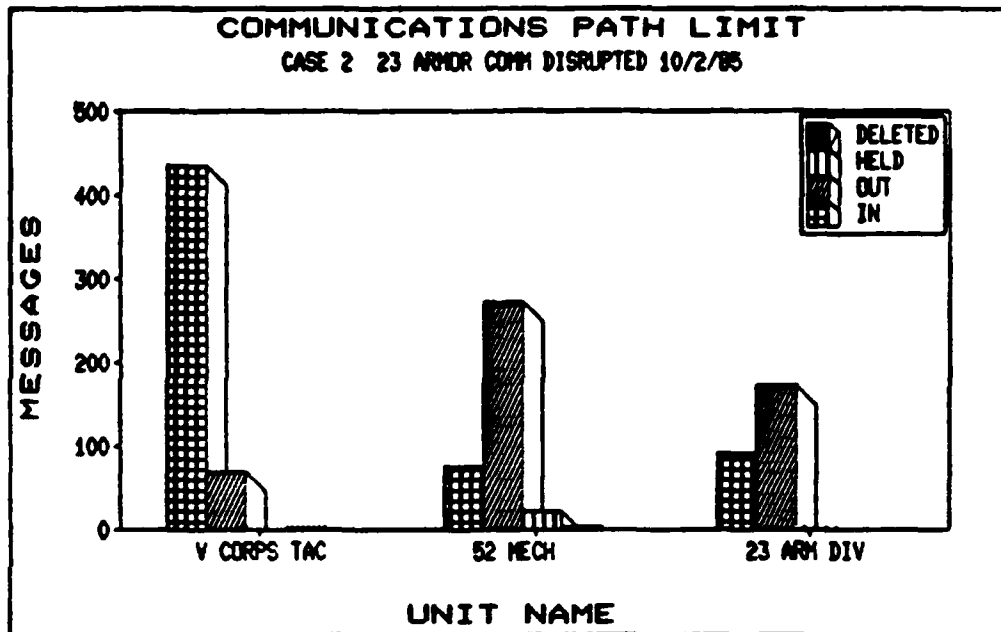

Figure S-2. SUMMARY GRAPHS FOR COMMUNICATIONS PATH LIMIT

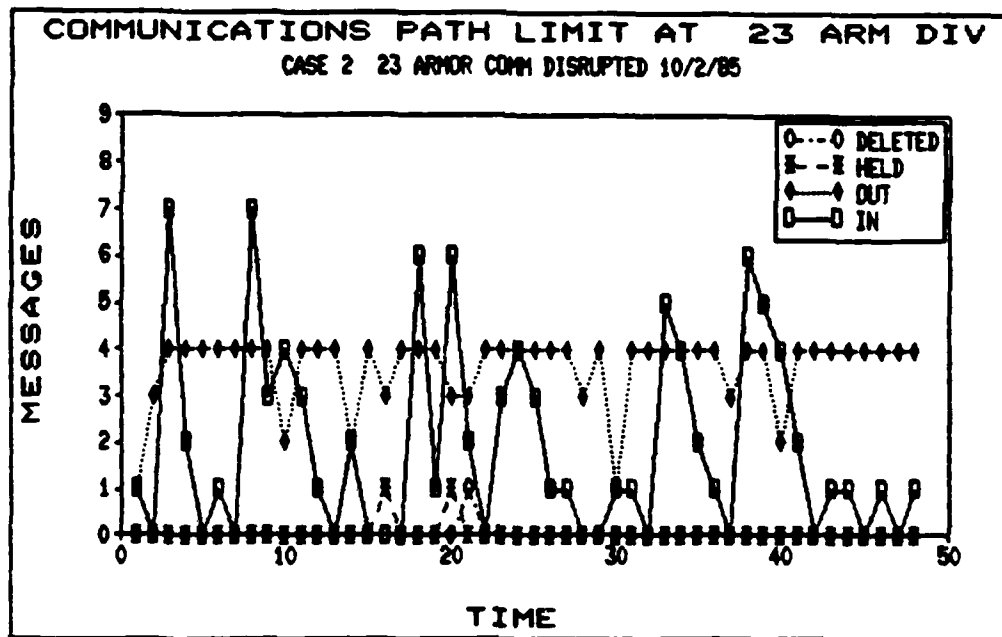
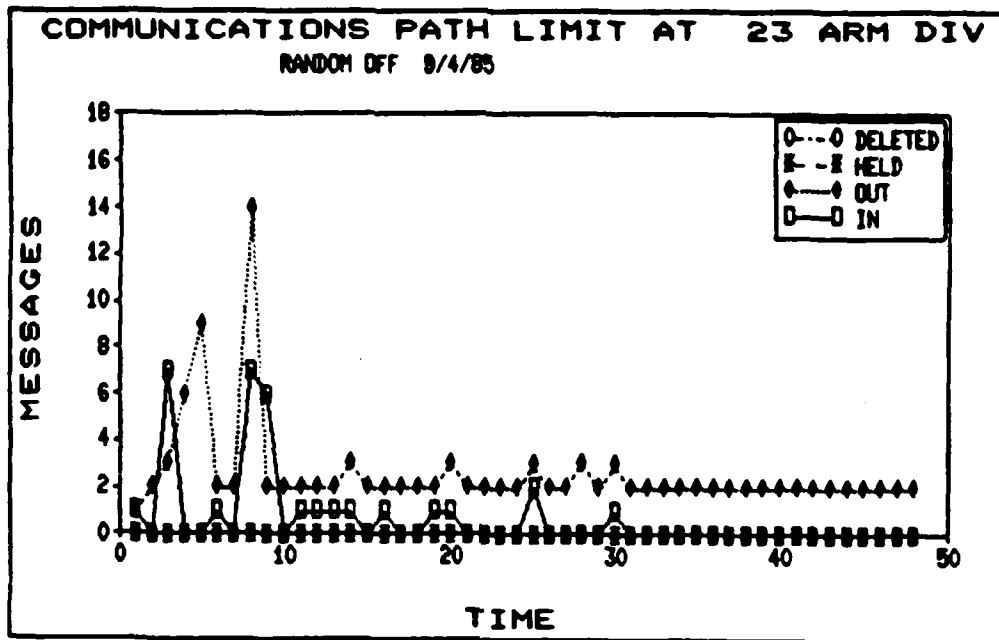

Figure S-3. TIME T GRAPH COMMUNICATIONS PATH LIMIT AT 23RD ARMORED DIVISION, CASES 1 AND 2

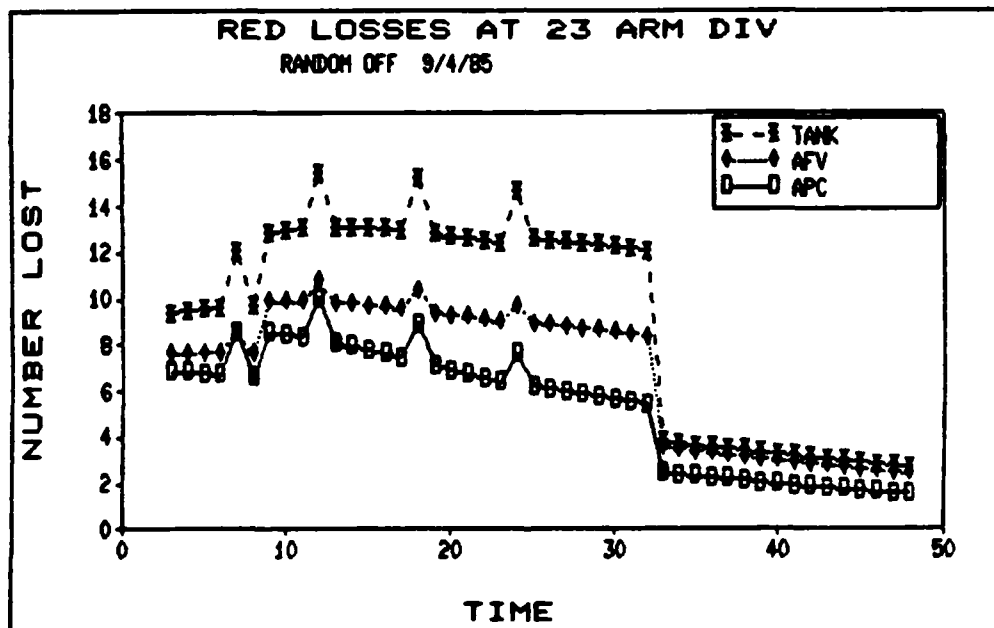
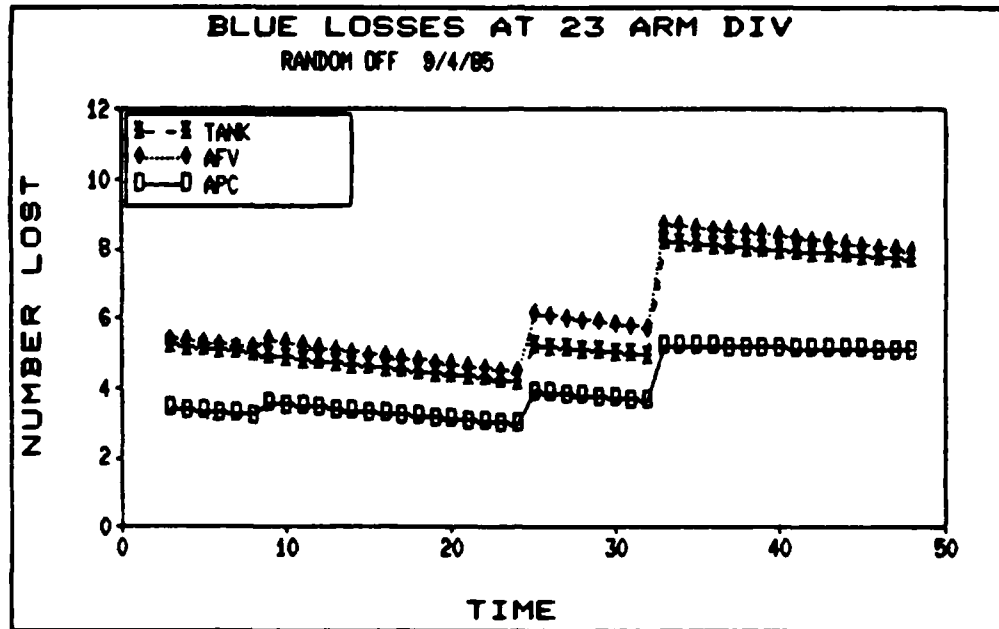

Figure S-4. TIME T LOSSES FOR BLUE AND RED (BASE CASE) AT 23RD ARMORED DIVISION

## DATA DEVELOPMENT

One of the primary tasks in the development of data for C<sup>3</sup>EVAL model is the design of the decision rules. Each decision rule has three parts: The rule parameters, the data required for the rule to be invoked and the guidelines for the results of the rule. Rules are assigned rule numbers to allow cross reference between the parts and used internally by the model to integrate message data segments with the appropriate rule when it is processed. Each rule is applied to a set of nodes in the scenario by assigning all nodes in the set a node type number and assigning that number as the process originator type in the rule parameters. Similarly, the required data (Message In) and results data (Message Out) data sets identify the originator and destination nodes using the node type as a key element. Setting up the decision rule file to provide continuity for node type, rule number, message-in type, message-out type and communications paths has been set-up as a formal procedure described in this report. Data for the procedure has been developed from Field Manuals, studies, and NATO STANAGs.

The types and capacities of the communications paths are based on the doctrine of the service that is being represented. The U.S. Army Field Manuals specify, for example, the number of communications links available to the commander, for operations (G-3), and intelligence (G-2). The scenario may, for example, specify that TRITAC equipments are or are not available. Between these sources, it is possible to determine the path's connecting nodes.

## D. FUTURE DEVELOPMENT

Suggestions are included for future development of the model. These include:

1. Logistics C<sup>3</sup>
2. Nuclear C<sup>3</sup>
3. New Theaters and Scenarios
4. Improved command nodes and decision making
5. Improved versimiltude in simulation, e.g., random processes
6. Extension of the pre- and post-processors.

## I. INTRODUCTION

### A. OBJECTIVES

The defined objective of this phase of the C<sup>3</sup>EVAL model development program is to "extend the model so that it may be used to display the combat consequences of changes in command and control processes and changes in communications network structure and capacity, where changes result from C<sup>3</sup> deficiencies identified in the period OJCS/C<sup>3</sup>S Performance Evaluation." The guidance provided also led to the preliminary development of an input processor and a graphics support package.

### B. BACKGROUND

The effort reported here is a continuation of the program started in 1983 with an investigation to see if a means could be provided that would satisfy the needs of JCS/C<sup>3</sup>S to do C<sup>3</sup> evaluations and to support the TFCA program. The second year of effort was devoted to a careful survey of existing models and simulations. This was extended to an evaluation of the use of the Warfare Environment Simulator (WES) of the Naval Ocean Systems Center (NOSC) and the formulation of a concept for JCS/C<sup>3</sup>S use. In the third year, the concept was implemented in the development of the first version of the C<sup>3</sup>EVAL model. Only preliminary rules and tests were conducted with this first version.

The requirements that made it necessary to undertake the development of a new model were several. The analysis method was originally intended to provide means for supplying a command/control/communications (C<sup>3</sup> input to the Total Force Capability

Assessment (TFCA) of the Joint Analysis Directorate (JAD). This need is still one that must be satisfied. However, the model is also to provide an analysis tool to JCS/C<sup>3</sup>S to assess Joint Staff C<sup>3</sup> system performance evaluation and thus an important criterion for the model is that it be usable by the Joint Staff. It thus must require only a minimum of support and should permit a quick turnaround on test cases.

The model has been designed to assess C<sup>3</sup> in terms of the flow and use of information. This means that while it treats communications it must also represent in some way the command and control processes and the interaction of C<sup>3</sup> with operations and combat. The model is an aggregated model for JCS evaluations and treats the flow and use of information at the higher levels of command and not the details of decision and action at the individual fire unit or aircraft level. The model must also be flexible in that it should be adaptable to a wide variety of command structures and scenarios. The C<sup>3</sup>EVAL model has been designed and developed to meet these conditions. Currently the data that has been installed is for a Central European scenario with focus on U.S. forces and the NATO command structure through which they act.

### C. APPROACH

This report on the work of the last year is in three volumes. The first volume contains a general description of the model and of the improvements that have been made. There is a discussion of the data used and the methods for its preparation. Examples of the capabilities of the model are given. The second volume is a briefing about the model and its capabilities. The briefing provides a complete summary, but is designed so that portions may be deleted and thus presented in a shorter time. This is followed by an examination of improvements that could be made that would readily extend the existing model and scenario

use. The final volume is a programmer's manual. Included are separate listings of the input processor, code, and the output postprocessor.

## II. C<sup>3</sup>EVAL MODEL

### A. INTRODUCTION

The purpose of this chapter is to describe the C<sup>3</sup>EVAL model in its current configuration. The additions that have been made to the model in the last year receive particular emphasis. In this chapter a general description of the model is provided.

### B. GENERAL DESCRIPTION

The major elements of the C<sup>3</sup>EVAL model are as follows:

- 1) Node and path structure: There are programmed rules for the operation of the nodes.
- 2) Action models: The models of combat that interact with the C<sup>3</sup>hierarchy.
- 3) Data structures: The data for node and path designations, time T inputs, combat data and decision rules.
- 4) Pre-processor: A means to provide for more user friendly input of data.
- 5) Post-processor: A means for developing graphics presentations of the results of a model run.

The node and communications path structure are chosen by the user so that any desired arrangement of the nodes and paths can be represented. Once a selection has been made, however, and rules have been chosen for the operation of the nodes, changes can be made only with considerable care. The level of aggregation is also user chosen. This is reflected in the characteristics of the combat units, in the time interval chosen and, naturally, in the number of nodes. Changes in time interval affect the

decision rules and the combat data used. The current version has divisions as the smallest ground combat unit and flights of aircraft for the smallest air-to-ground unit.

### C. DATA INPUT

The data input structure contains all the data necessary for the operation of the model. The design is such that there are but few data in the model so that the user has complete access to the inputs so that the user can control the cases to be run as desired. The full schedule of data inputs are as follows:

1) Nodes: The designation of the nodes, their commander (whom do they report to), their subordinates (who reports to the node), coordinating nodes, alternative nodes for sending messages when normal lines of communications are unavailable.

2) Node limits: Input and output limits to represent constraints on the capabilities of the nodes to either receive or process messages. Node limits can be specified by time interval.

3) Communications networks: The specifications of the numbers of paths, their kinds and their capacities that connect each node with other nodes. Communications capacities can be specified by time interval.

4) External messages: All scenario inputs that include messages that report, for example, EW events, changes in the number of weapons available to combat units, or changes in posture of combat units.

5) Combat data: The numbers of weapons assigned to each combat unit and their posture.

6) Aircraft data: Types of aircraft, numbers of aircraft, and availability by time period.

7) Helicopter data: Characteristics and numbers by time period.

8) Rules: These are the representation of the decision processes by which messages are generated. Rules are specific to

the node type, organization and doctrine of the C<sup>3</sup> system being considered.

Of these data categories, the first has been implemented with a data dictionary and instructions in an input-processor to facilitate data input by the user.

#### D. SIMULATION DESCRIPTION

The model is designed to be able to represent any command structure that is an arrangement of command nodes and communications paths with an interaction with operations and, in particular, with combat operations. The working model as it is currently structured represents a slice of the command structure in Central Europe as shown in Figure II-1. The structure of nodes and paths has been extended from that which existed for the original development and test of the model. The level of aggregation has been changed from brigades as the smallest unit to divisions. This smallest ground unit is the combat unit. The levels of command have been extended above corps to CENTAG, AFCENT/AAFCE and SHAPE. The representation of corps has been changed so that there are nodes for Corps Main, Corps Tac and Corps Rear. The TACP at division and the ASOC at Corps Tac have been combined into the nodes for division and Corps Tac. This means that there is no delay between the Air Force and Army units. The message-generating capability of these units for sending messages to appropriate Air Force or Army units has not been altered and each can still perform its appropriate functions. In addition, the Corps Tac/ASOC and Corps Main have been added for another corps area so that the addition of another corps is facilitated. The user can pick any arrangement of nodes and paths that may be desired. This is a part of the flexibility of the model. The command structure may represent that of a lic. Service, joint or combined force, provided that the rule structure and messages can be specified. The user may establish as

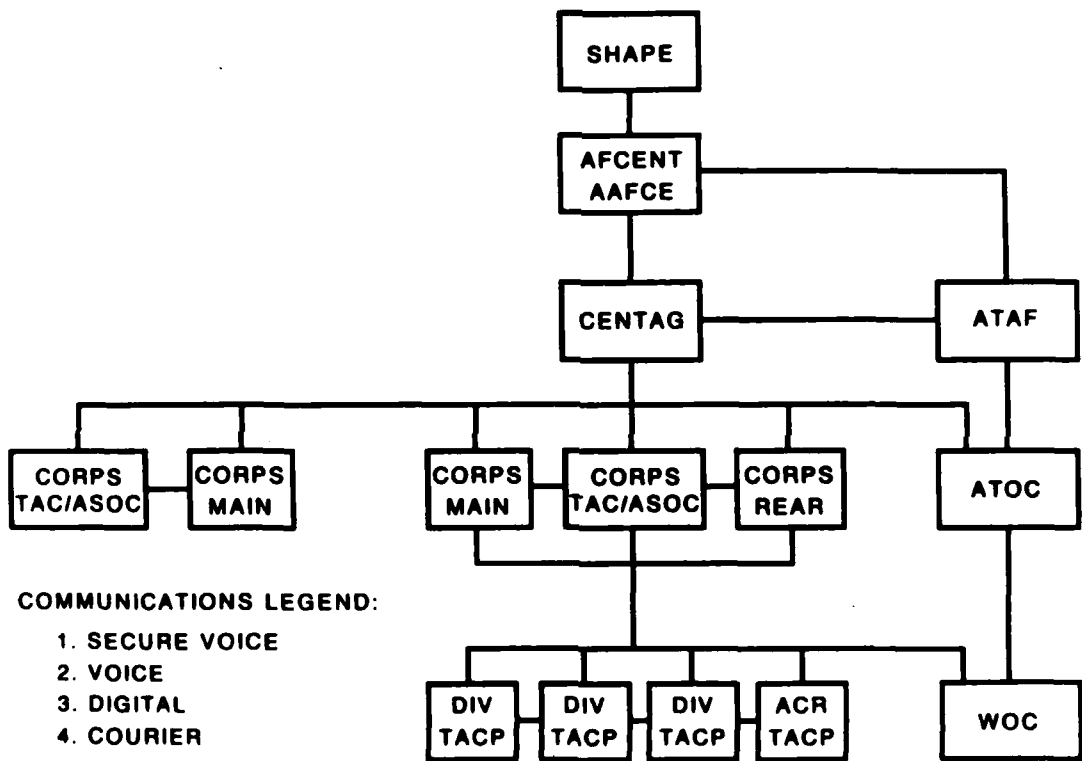

8-30-83-2L

Figure II-1. COMMAND STRUCTURE IN CENTRAL EUROPE

many nodes as desired. The limits will be determined partly at least by the effect on turn-around time. It is probably worth noting that in the use of the model that the point may be reached that when particular problems are to be investigated, only that portion of the structure relevant to the particular problem should be retained. This would mean that turn-around time for that investigation would remain low. Care must be taken in such simplifications of structure since it could lead to serious alterations in the behavior of the system and the flow of messages. A straightforward example of such a change would be the absence of some of the alternative paths for message delivery.

The user establishes the number and description of the paths that connect the nodes. While it is emphasized that there is aggregation of the communication paths, there is considerable flexibility in their designation and use. Figure II-2 shows the current path connections for V Corps Tac. There are a total of 32 distinct paths that are identified as secure voice, open voice, digital and courier. The capacity of the path is defined by the number of characters that can be transmitted within the designated time interval (in this case, within one-half hour). This means that when voice is the mode being used, the capacity of the path will be limited to the number of characters that can be spoken within the one-half hour and not by the capability of the system to transmit millions of bits per second. The paths can be designated for specific use, although this has not been done in the current work. An example of such a designation would be the identification of paths 5, 6 and 7 as part of the Air Force Tactical Air Net. The Air Force messages that would use this net would have to be so designated.

The paths represent the total capacity available of the specified mode of transmission between two nodes. They do not specifically represent a particular communications link except in

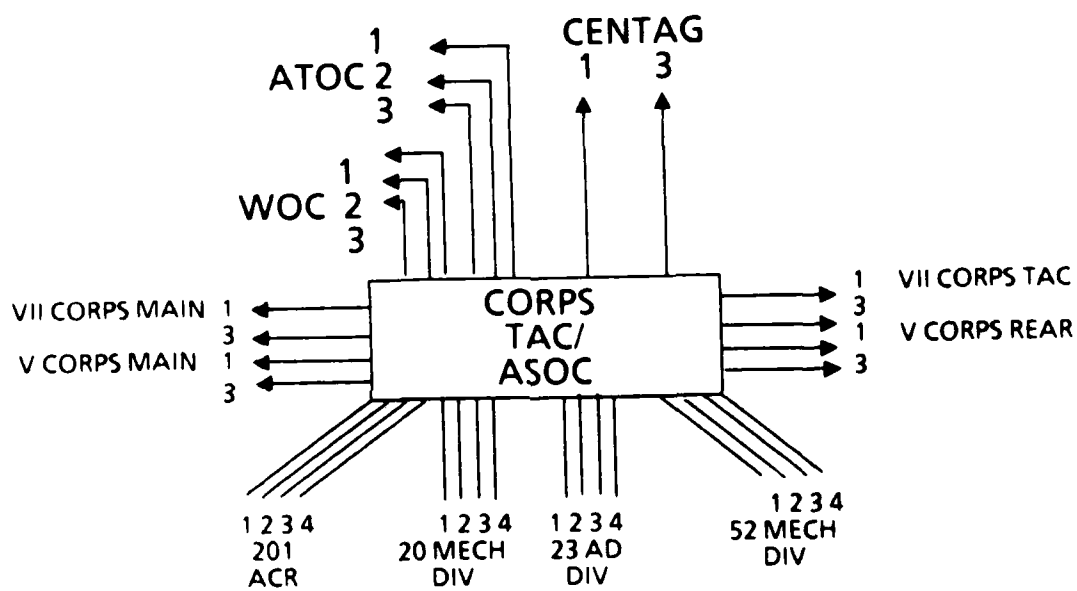

- 1 SECURE VOICE
- 2 VOICE
- 3 DATA
- 4 COURIER

Figure II-2. PATH CONNECTIONS WITH V CORPS TAC

the fact that they include that link with all other links available of the specified kind between the two nodes. If there are switches between the two nodes, they are not separately identifiable in the model's current configuration. If the communications capacity is diminished in a given series of time intervals by jamming, unreliability of a switch or combat damage to a switch, this is represented by a reduction in capacity input by the user. The nature of changes in the communications system due to changes in message switches can be determined from a communications network model to provide data for input to the C<sup>3</sup>EVAL model.

Each node has the same internal structure (Figure II-3). Each node can be designated as belonging to a generic unit type, i.e., division or wing operations center (WOC) and when rules are developed for that generic type, all nodes designated to be of that type will operate according to those rules. Each command unit has three files on the input side that may contain messages. The messages in these three input files are reviewed each time interval. The three input files are (1) the file of messages from other command nodes/units, (2) the file of messages input by the user (the external file) that are scenario-specified messages and (3) the file of messages held from a previous time interval for one of three reasons. The first reason is to represent the fact that it may take more than one time interval to process a specific kind of message, e.g., the process time for certain types of reports may normally take two hours to produce. In this case, the messages will be held in the future file for four time intervals. The second is that scenarios' messages may be held in the future messages file if the capacity of the available communications paths is exceeded before that particular message could be sent. In that case, the message will be held in the future message file and an attempt will be made to send it during the next time interval. If it still cannot be sent, the process

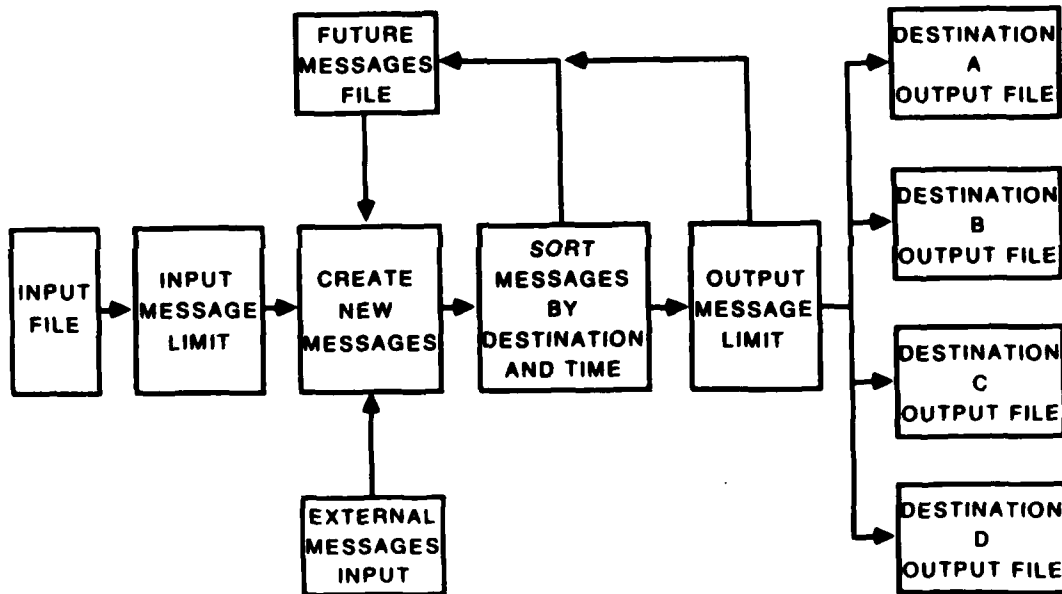

4-5-64-10L

Figure II-3. NODE INTERNAL STRUCTURE

will be repeated until the designated age of the message has been exceeded and the message will be destroyed/killed. The output record will indicate how many and which messages have been destroyed/killed and how many have been held. Finally, messages may also be held in the future message file when they have not been sent, due to the output message limiter. Specific messages may be held for a period of time determined by a random draw if "random" has been turned on and the message is one of those that have been designated.

The first process to which messages are subjected may be the input message limit. This is a new feature added during the current program. This limitation may be set by the user for specified numbers of time periods by node. It is intended to represent such events as a limitation on the ability to receive messages due to events such as damage to antennas or the unit being on the move. The limitation is designed to pass priority one messages and a specified number of lower priority messages. The input file messages are sorted as they come in.

The "create new messages" process is central to the operation of the model of the command node. New messages may be generated because it is time for that message to occur, i.e., it is a periodic message. A new message may be created because a certain message has arrived. The new message in either case may require the existence of one or several specified messages in the file before the new message is created. The new message will be created according to the rules that have been established in the rule data file. Rules are discussed under the rule data development.

An important part of the additions made during the current work is the process for the reallocation of corps controlled combat resources. This includes the corps approval of requests for CAS/BAI with the ASOC passing on approved requests to the ATOC and WOC. The allocations are first made for the day and are

sent by corps to division. This action is evident in the equipment lists of the division by weapons type. For corps artillery and helicopter resources the assignment is from the scenario input and are made to division as external messages with inputs to the combat matrix. Reallocations of these resources within the division take place within the combat matrix as posture or intensity of the battle changes, and are not visible as identifiable decisions with messages at the level of aggregation of the model.

When additional resources are required above those allocated to the division, a request is made to corps. The process that has been installed in the current work is such that an air request is triggered when the force ratio at division exceeds an amount designated by the user. This air request is sent to Corps Tac. The division also supplies Corps Tac with spot reports on the attrition suffered by the division. If random is on, these reports will be increased or decreased by a random amount that is the same for all items in the weapons type list. The division also sends spot intelligence reports of attrition of the opposing Red forces. These are also randomized when Blue's are randomized.

The information on which the corps makes decisions is thus different from that at division, since the reports on either friendly or enemy losses will be delayed by at least one time interval and may be in error by the random factor. The tables of equipment at corps may also differ from those at division. Currently the table of equipment used at division for calculations is the "ground truth." This is a convenient way to retain a baseline for comparison purposes. If a different set of values was desired by the user, it would not be difficult to base division calculations on values that were delayed or "randomized" from ground truth. The corps basis for calculations is a table of equipment of Red and Blue that is input by the user that represents the corps perception. For Red forces this list is currently a generic description of Red forces. If the division

has reported that it is being attacked by an armored division, the corps estimates will be based on that report whether it is correct or not. Based on the force ratio calculated, Corps Tac will agree or not with the allocation of air resources to the division. If corps agrees, the ASOC will forward the request to the WOC. The WOC will fulfill the request depending on the availability of resources.

There is also a representation of resource allocation and reallocation at division level. The primary allocation of corps resources is made by scenario input for the 24-hour period. The reallocation of those resources at division is by the change of posture, which can result in changes of rate of fire. These changes can occur due to changes in combat intensity, due to external (scenario) messages or from messages received from corps.

Messages that are to be sent within the current time interval are moved through the output message limiter. This limiter has been added as a part of the current work effort. The output limitation is to represent limits on the capability of the command node to generate messages. This output limitation could, for example, represent damage done to the command post and thus reflect reduced capability. Similar reduction in capability could occur when the command post is on the move. The output limit restricts the number of messages by priority.

Messages that are to be sent within the current time interval are moved to a destination file. Each unit has a destination file for each unit that it may communicate with during the run. The first step in the process determines how messages will be sent is to compare the capacity required by all messages to be sent on their primary transmission path with the total capacity of the path. Capacity is measured in terms of messages and hence number of characters that can be sent during the time interval. Capacity can be determined by the physical properties of the path, as with TTY, or by a standard capability such as the number

of characters that can be transmitted, as by voice. When the required capacities are insufficient, the priorities of the messages are compared. Those messages that cannot be sent are bumped to the alternate communication types, on which the same process is followed. If the messages still cannot be sent, the messages in the hold queues are assessed to determine if they can be sent through alternative destinations where they would be forwarded. If this is done, the message is flagged so it can be traced. The flag also tells the alternate destination not to do anything to the message except to try to send it on to its original destination. When all this is completed, the process is repeated. This is to cover the possibility that if a message assigned to its first alternate destination is bumped by a message that is being re-routed, it is checked for its alternative routing.

The "action models" are to represent aspects of the military combat and support operations which affect the C<sup>3</sup> system and which are affected by that system. The representation of ground force engagement processes that are included in the current version of the model uses a matrix method of calculation of the attrition processes. This method is similar to the dynamic model used in the TFCA games. The matrix method allows for the calculation of attrition by fires of N Blue weapons on M Red weapons with allocation of fire and engagement rates according to input data. The kill probabilities are also specified. Changes in the number of weapons available could also cause the initiation of a message as, for example, when the force ratio reaches a certain level a request is made for supplemental close air support.

The airbase model contains representations of a WOC and CRC. The WOC controls the allocation of available aircraft on the ground to the requests for air support that it has received via messages. The CRC receives control of sorties once they are airborne. The CRC processs calculates the time over target,

modifies the appropriate unit combat matrix to include the sorties, calculates attrition to the enroute aircraft and schedules them for control by the WOC after they land after accounting for attrition in the combat area. Only one mission type is flown in the present configuration, CAS/BAI.

#### E. GRAPHICS POST-PROCESSOR

Another major addition to C<sup>3</sup>EVAl during the current work is a post-processor for graphic summaries. The first step will be for the user to assign a title that is printed on each graph. Output summaries are available from a menu as follows:

- (1) Quit
- (2) Communications path limit
- (3) Input limit
- (4) Output limit
- (5) Combat support
- (6) Losses

The user then selects the number of units to be graphed. This will be between one and five, the constraint being that more would be too confusing on a graphic presentation. The selection is made from the list of unit command nodes that have been included in the model. Currently this list includes:

- |                    |                   |
|--------------------|-------------------|
| (1) SHAPE          | (8) 52 Mech       |
| (2) AFCENT/AAFCE   | (9) WOC           |
| (3) VII Corps Main | (10) ATOC         |
| (4) VII Corps Tac  | (11) 4ATAF        |
| (5) CENTAG         | (12) 23 Arm Div.  |
| (6) V Corps Rear   | (13) V Corps Main |
| (7) V Corps Tac    | (14) 20 Mech      |
|                    | (15) 201 ACR      |

The user is asked "which units do you want to graph?" The user should usually select no more than three, or the graph will

become too crowded.

In the following examples of all the available graphics are given. Two cases are shown so that it can be seen that changes in C<sup>3</sup> does result in changes in information flow and use and on combat operations. No analysis of these effects has been attempted, however.

In the following two examples, each of the output graphics are given. The purpose is twofold: (1) to portray the nature of the graphics, and (2) to demonstrate the effects that changes in the command, control and communications system can have on the flow and use of information. The first of the demonstration cases assumes that all nodes are operating at full capability, all communications paths are available and the "random" switch is off. This latter assumption means that there is a list of messages that will not be activated. They represent event-caused messages that the user does not wish to specifically indicate in the scenario but which are messages that would be expected to be sent during the course of a day. They include, for example, counter-intelligence reports, possibly EW events and others. The second case, designated on the curves as "Case II," includes considerable disruption in the operations of the C<sup>3</sup> system. In Case 2 the random is on, so that there are significantly more messages in the system.

Case 2 is different than the previous case because of the following changes:

- A. Random process is turned on (indicated above).
- B. External messages have been added at times 18, 22, 32, 38, 44 and 46. These include additional air requests at times 23, 32, 38, 44 and 46.
- C. Limits
  - (2) 23rd Armored Division has input limits of 2 and 4 instead of 17 and 22 messages.

- (3) 23rd Armored Division has output limits of 4 and 6 instead of 17 and 19.

D. Paths

- (4) At time 8 the paths between 20th Mech Div and 23rd Armored Division are reduced to only 500 characters on path type 3.
- (5) At time 12 the paths between 23rd Armored and 52nd Mech are reduced to 300 characters on type 1, 500 characters on type 3 and 500 characters on type 4. Also, all paths from 23d Armored to V Corps Tac are cut completely. 23rd Armored is reduced to 200 characters on type 1 and 100 characters on type 3 paths to V Corps Rear.
- (6) At time 22, 20th Mech reestablished path type 1 to 23rd Armored, but only at a reduced capacity; however, it loses path type 3 completely.
- (7) At time 32 the paths between 23rd Armored and 52nd Mech are changed to 2,000 characters on type 1, 300 characters on type 3 and none for type 4. In addition, 23rd Armored gets path type 1 at a rate of 1,000 characters back to V Corps Tac.
- (8) Also at time 32, 23rd Armored reestablishes full communications with V Corps Rear and 20th Mech.

The first of the graphics to be shown is Figure II-4, summary graphs for Communications Path Limit. This shows the summary of messages sent at V Corps Tac, 52nd Mech and the 23rd Armored Division. Note first that there are many more messages in the system for Case 2 and that for this case there are large numbers of messages held or deleted because of the limits on the capability of the nodes and the capacity of some of the communications paths. If greater detail at one of the nodes is desired, it is possible to obtain the Time T graph at that node. In these graphs the "Time" is the half hour time interval. The 48 time

intervals shown thus represent one day. Figure II-5 shows the Time T graph for the Communications Path Limit.

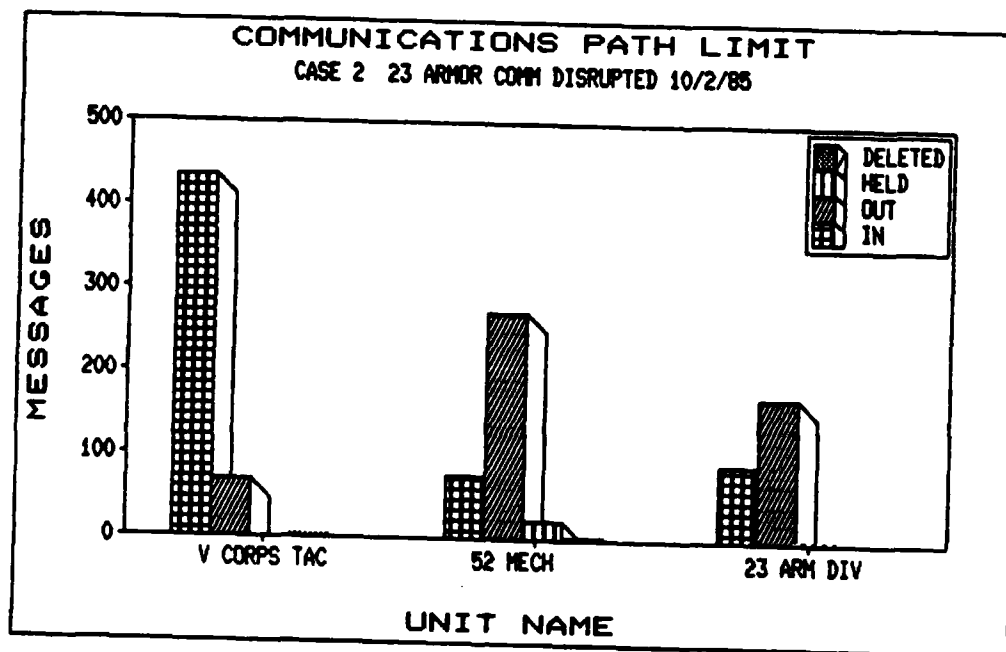
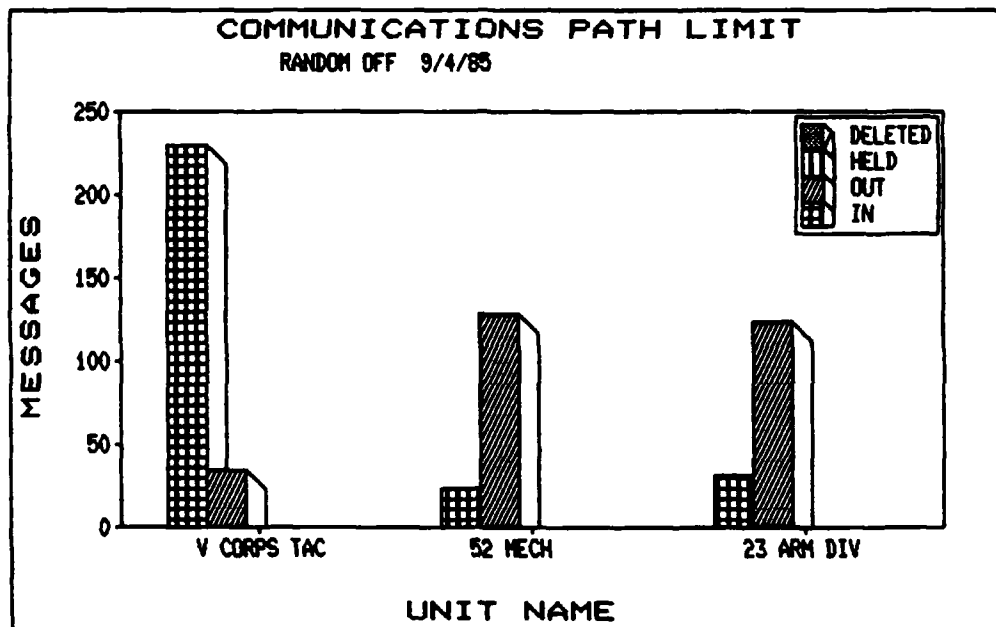

Figure II-4. SUMMARY GRAPHS FOR COMMUNICATIONS PATH LIMIT

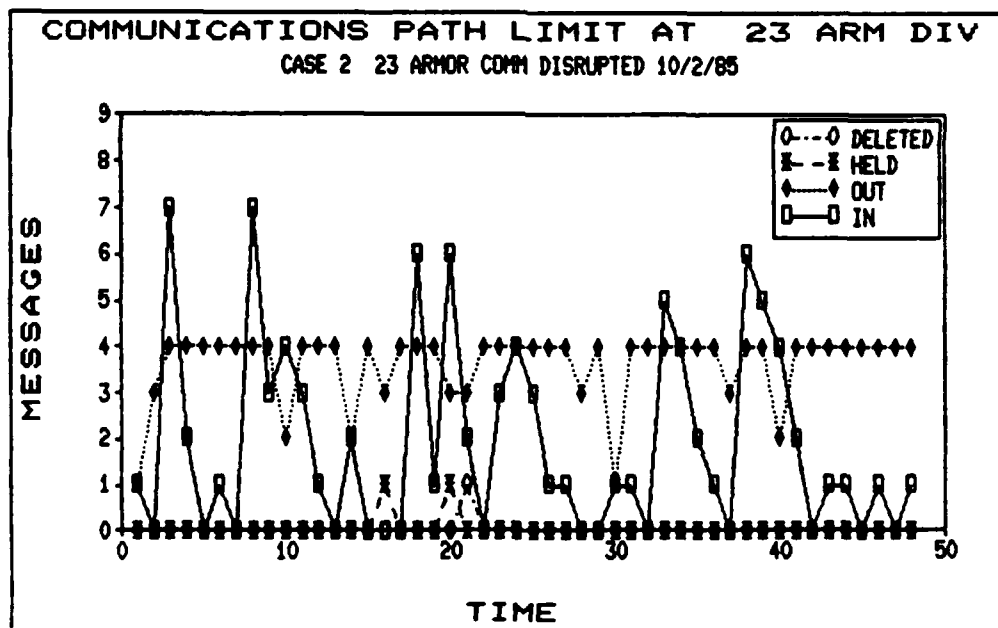
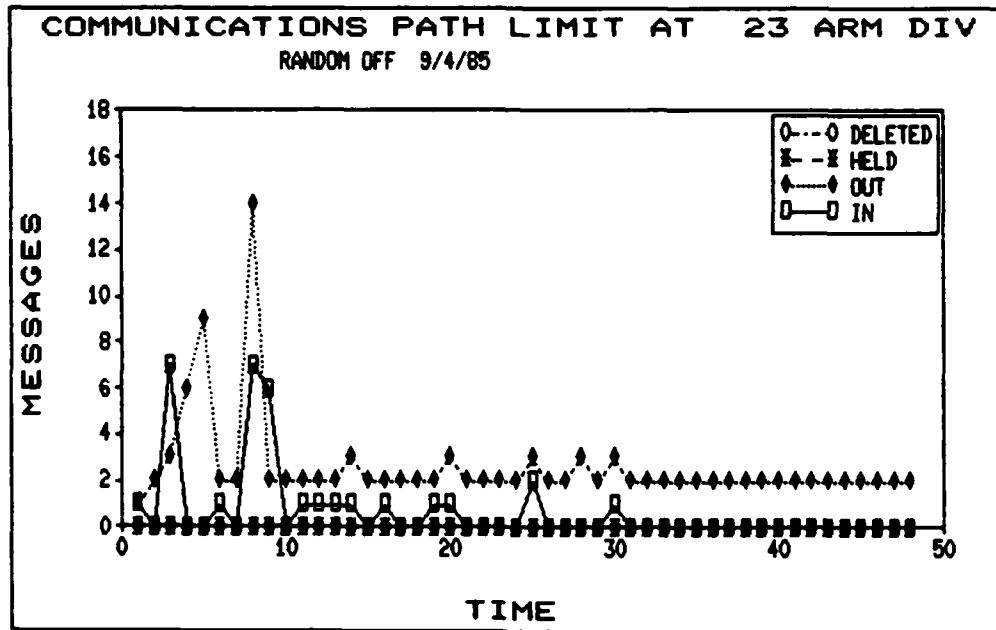

Figure II-5. TIME T GRAPH COMMUNICATIONS PATH LIMIT AT 23RD ARMORED DIVISION, CASES 1 AND 2

Communications with that node have been disrupted as described in the scenario. The next of the examples (Figure II-6) is the summary input limit graphs. With the random on, the number of messages is again shown to be much greater. The primary effect on the 23rd Armored Division is the number of messages that are held or deleted. In the Time T history (Figure II-7), the times at which the "Deleted" and "Held" messages occurred can be seen. The impact of the additional messages results in a significantly higher workload at the C<sup>2</sup> nodes.

Figure II-8 shows the summary graph for the Output Limit. This is accompanied by the Time T graph (Figure II-9) for the Output Limit for the 23rd Armored Division. The impact of the output limitation on the 23rd Armored Division node results in a high message delay or loss rate. These are all of the graphs that are currently available that show the message flows. The remainder will illustrate the impact of the C<sup>3</sup> changes on combat support and losses on each side.

According to the menu, the next of the choices is for combat support. The summary graph for CAS and helicopters is shown in Figure II-10. This is accompanied by the Time T plot, Figure II-11. The arrival of the additional CAS sorties is clear.

The plots of losses of the two sides are the last major set of graphics available. The user can choose the combat unit for which graphics are desired and the combat systems to be plotted. It is recommended that no more than three combat systems should be chosen for plotting at one time or the graph will be too crowded. The graphics for losses are presented in Figure II-10 through Figure II-15. The presentation gives all summary graphs for the base case, then the summary graphs for Case 2. These are followed by the Time T graphics in the same order.

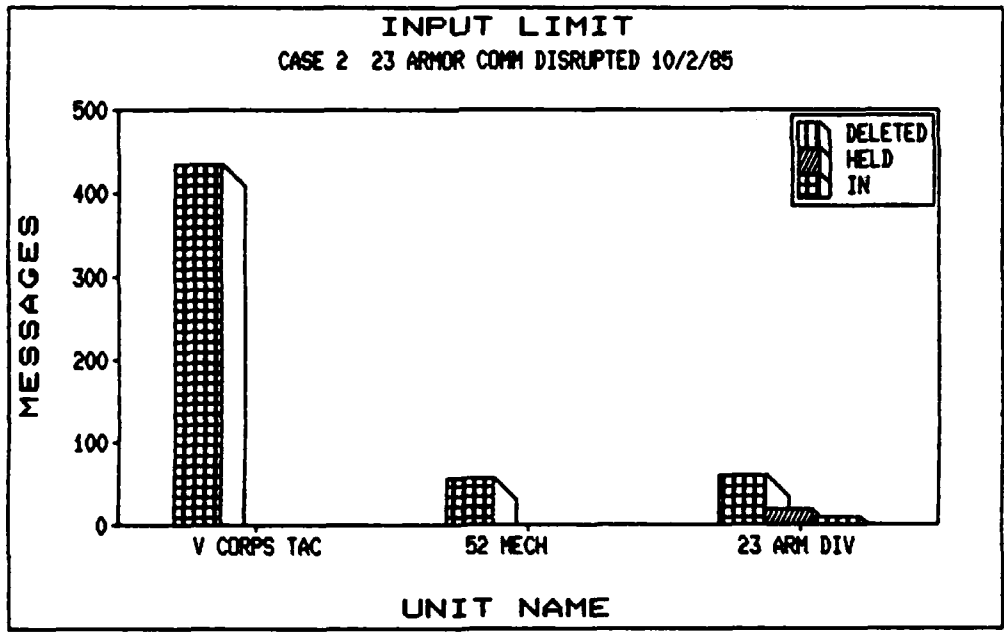
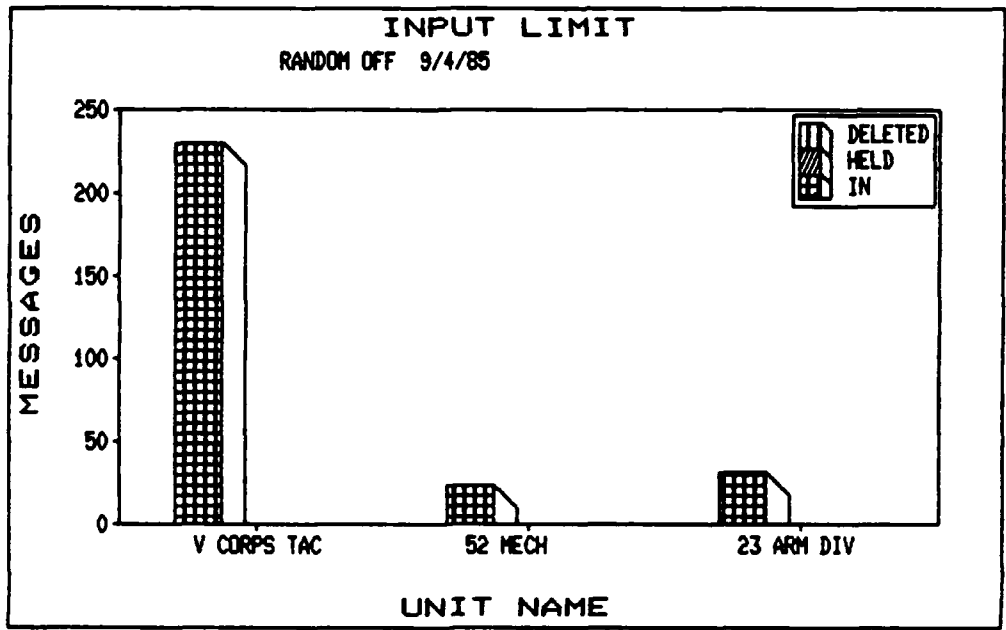

Figure II-6. SUMMARY GRAPHS FOR INPUT LIMIT

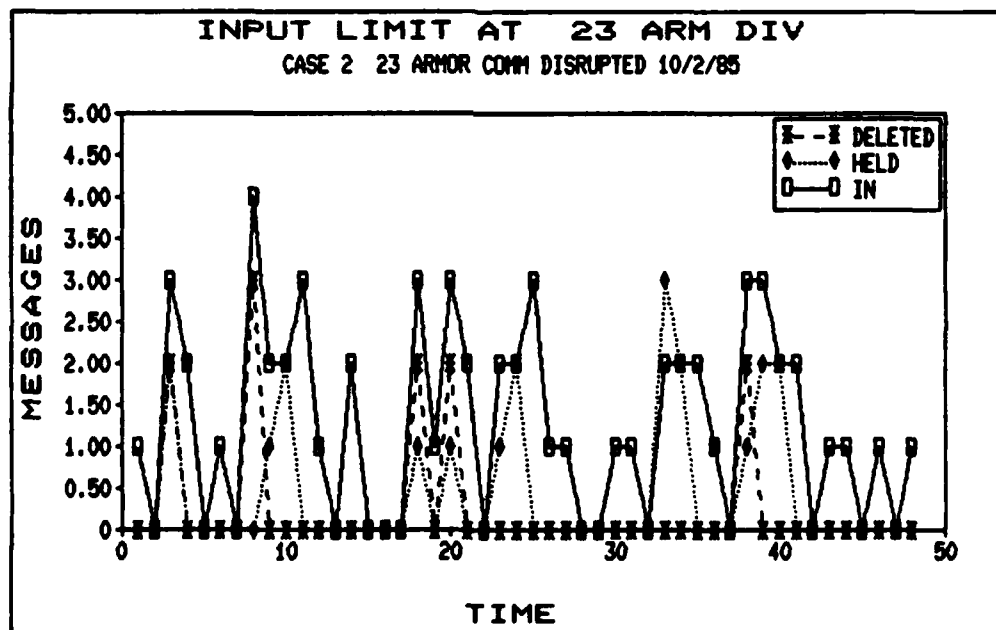
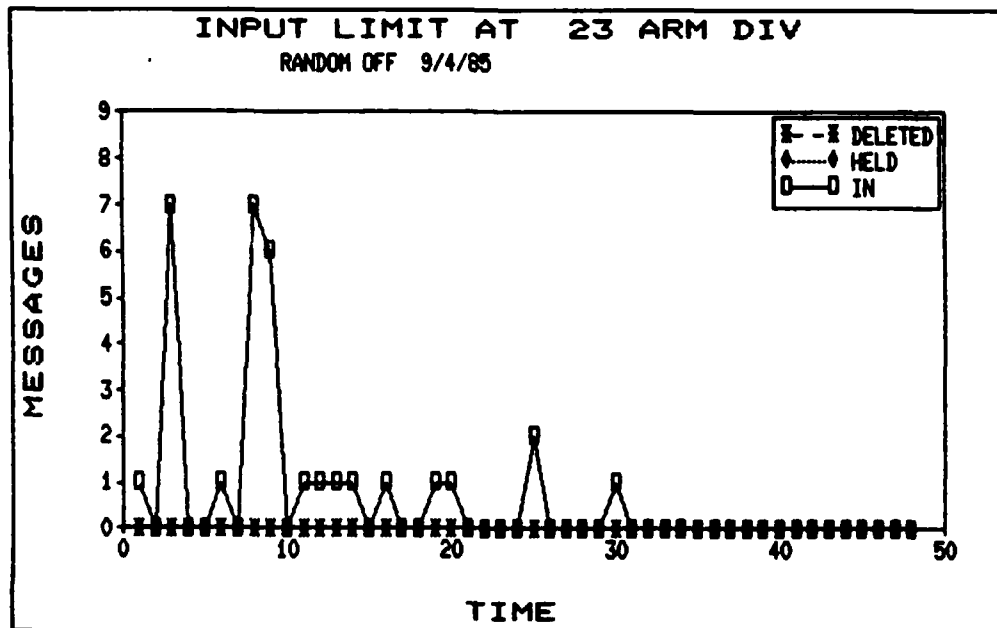

Figure II-7. TIME T GRAPH FOR INPUT LIMIT AT THE 23RD ARMORED DIVISION

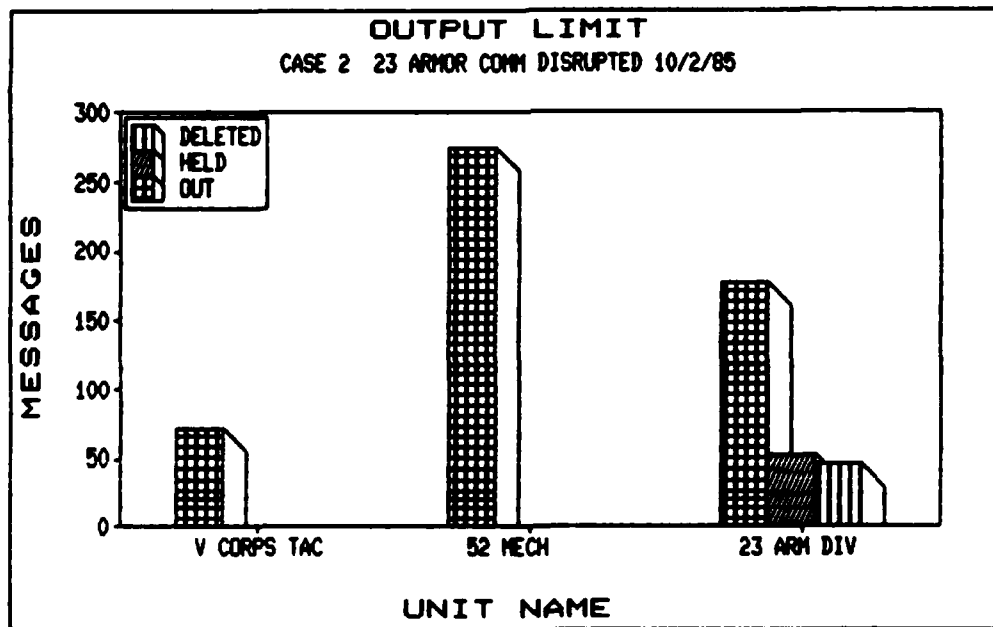
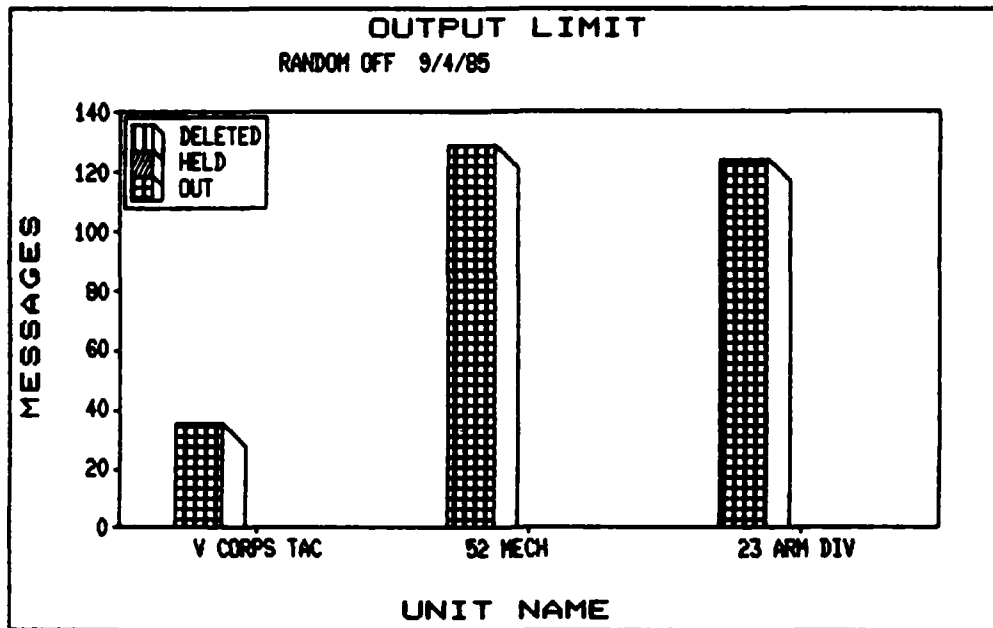

Figure II-8. SUMMARY GRAPH FOR THE OUTPUT LIMITATION DEMONSTRATION

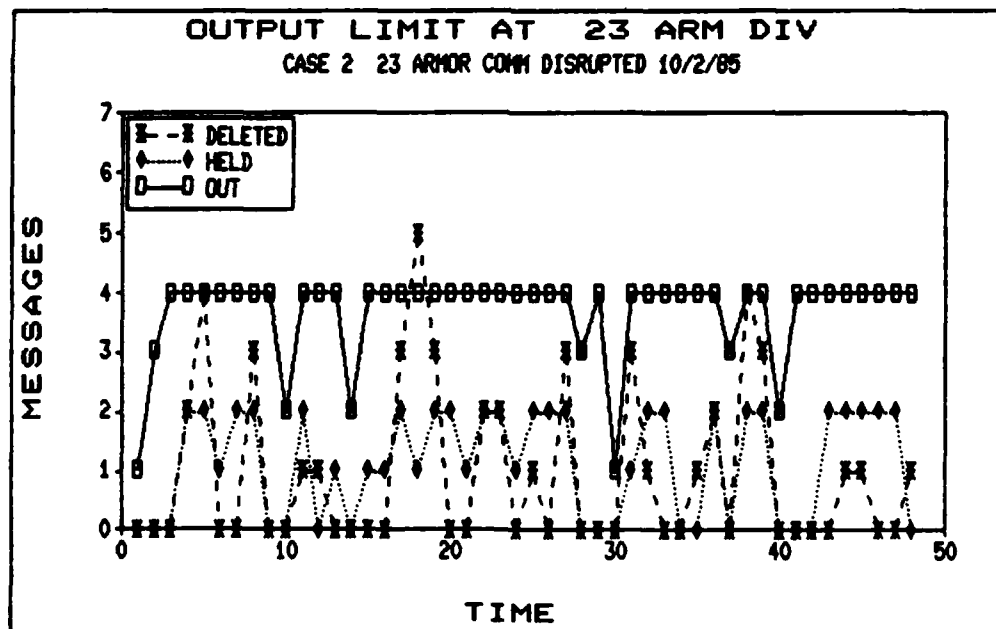
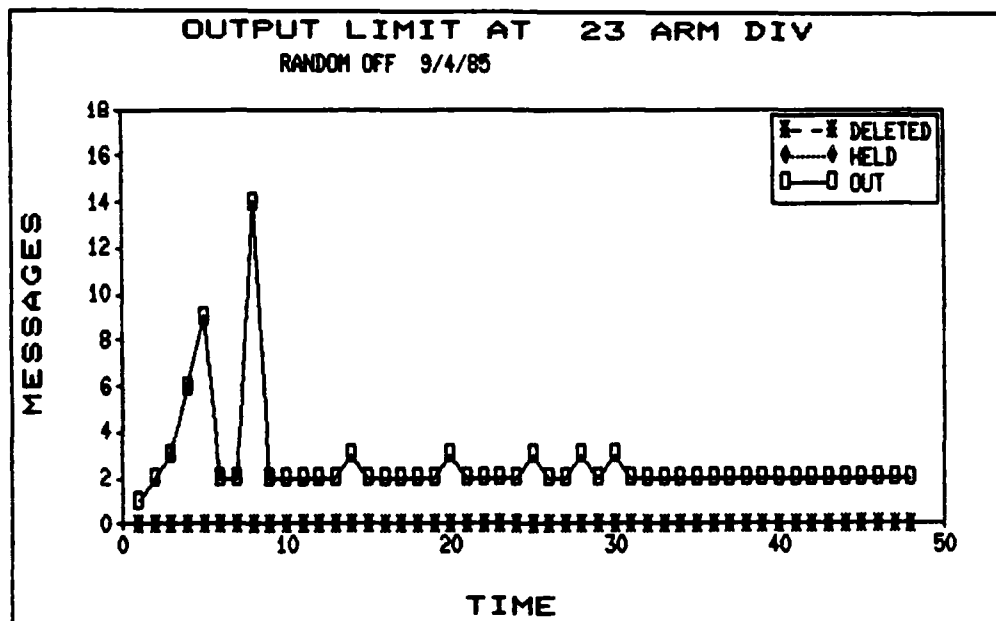

Figure II-9. TIME T GRAPHS FOR THE 23RD ARMORED DIVISION, OUTPUT LIMIT DEMONSTRATION

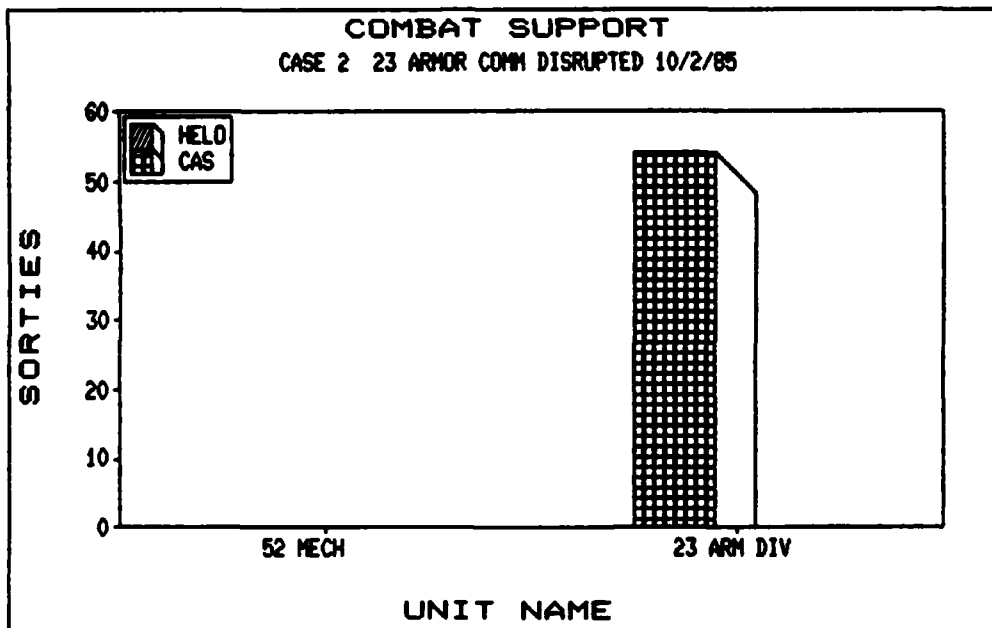
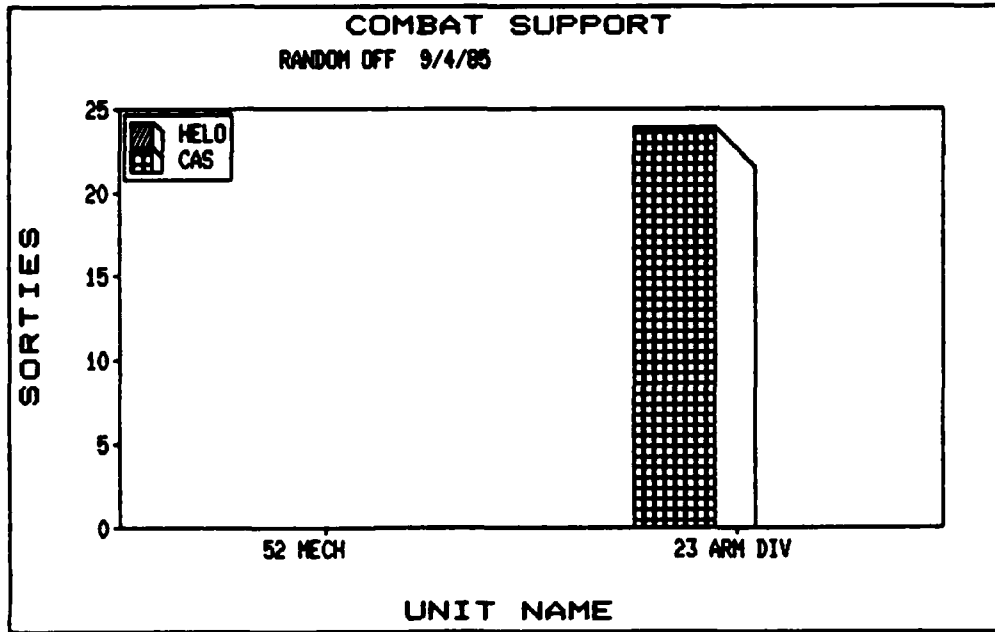

Figure II-10. SUMMARY GRAPH OF COMBAT SUPPORT

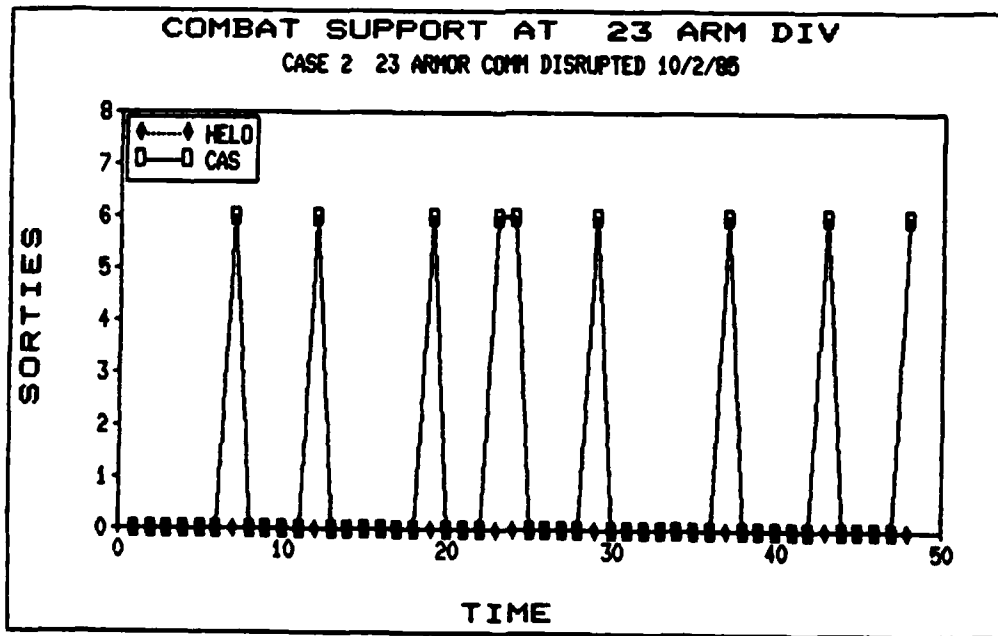
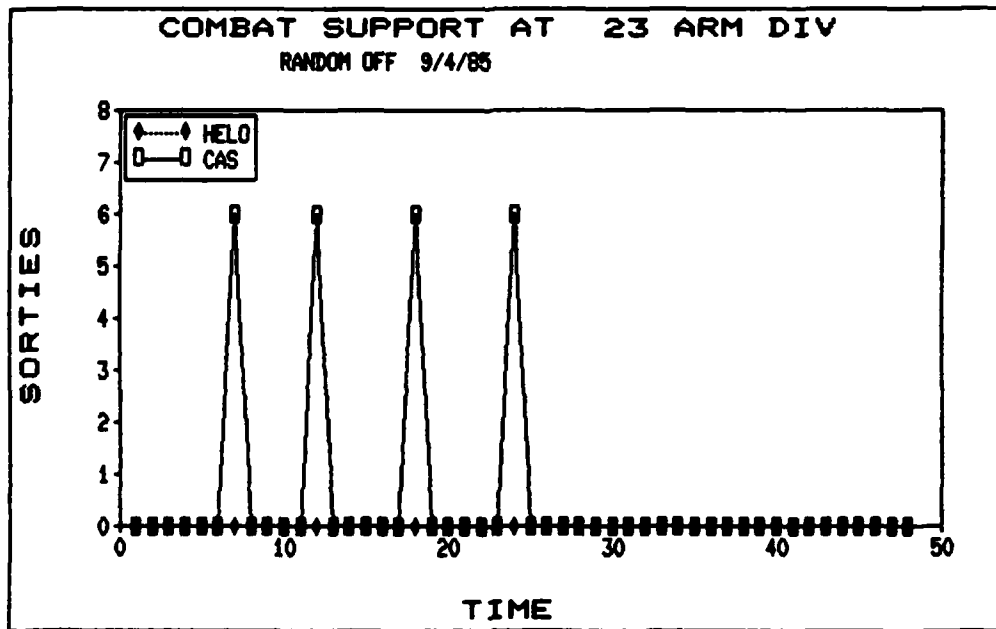

Figure II-11. TIME T PLOTS OF COMBAT SUPPORT/CAS SORTIES

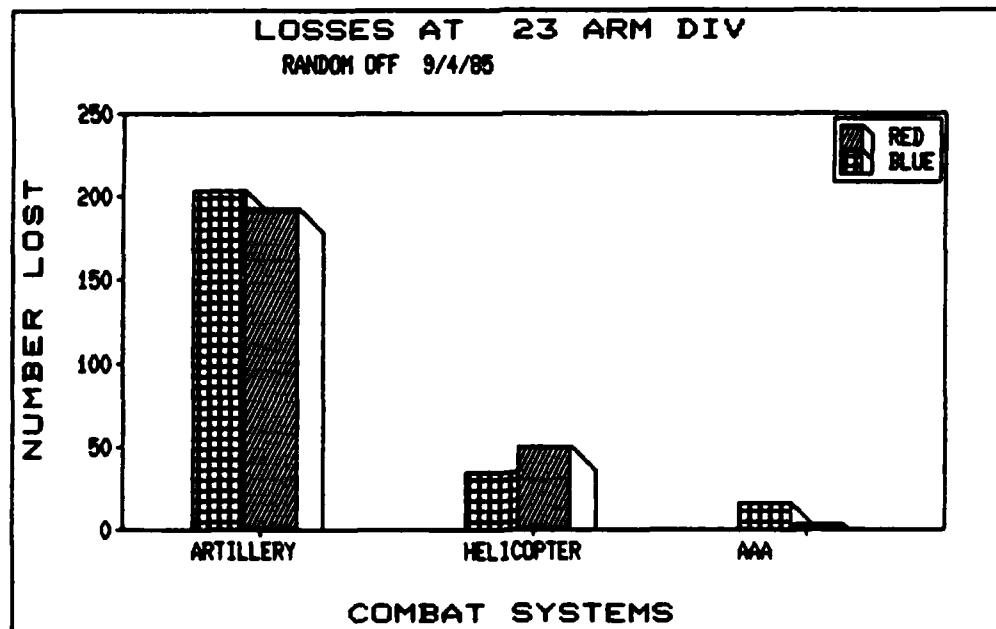
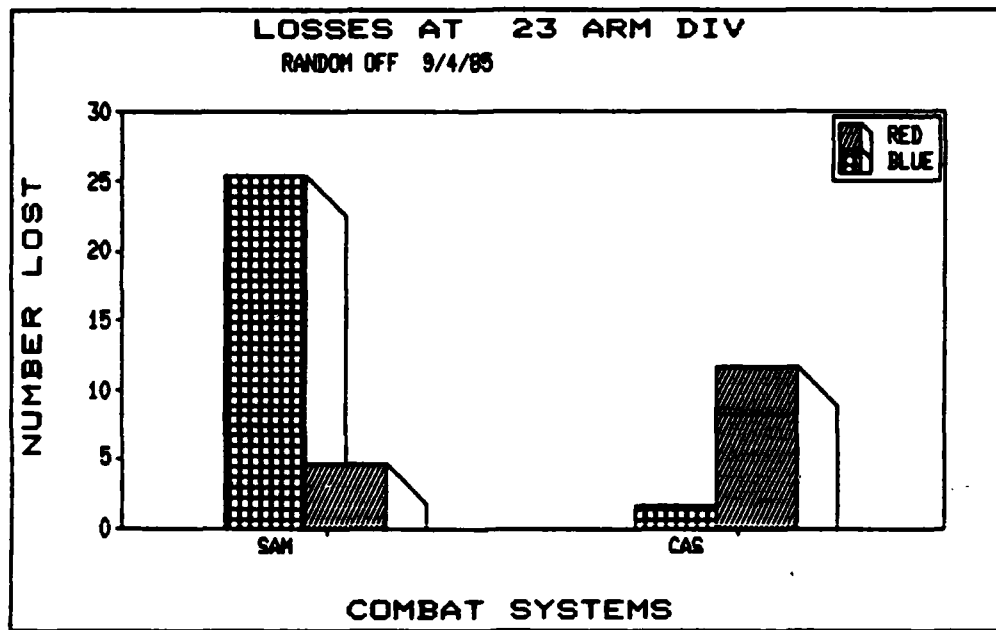

Figure II-12a. SUMMARY GRAPHS OF LOSSES AT THE 23RD ARMORED DIVISION (BASE CASE)

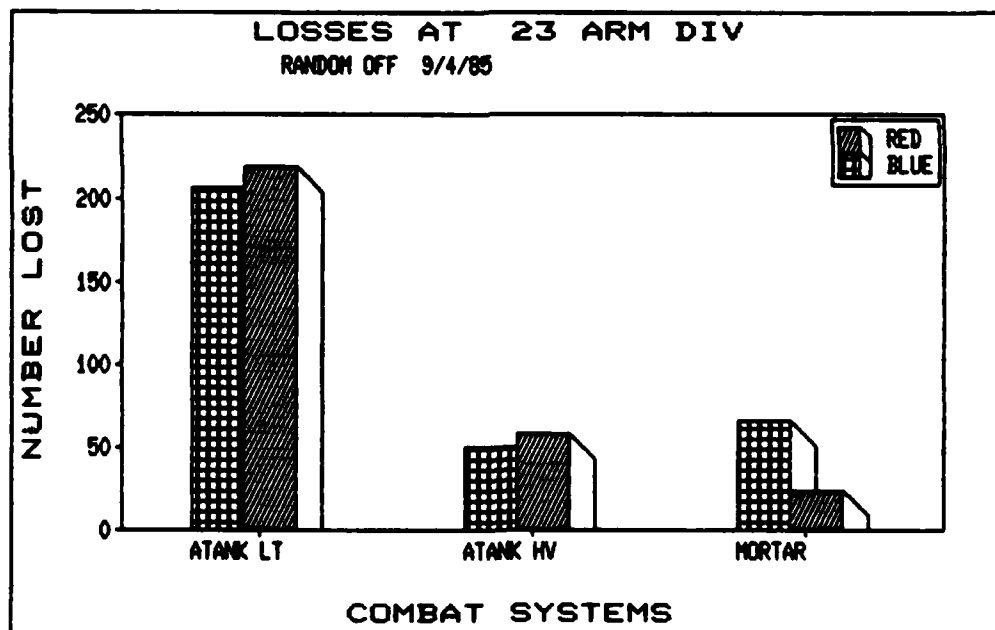
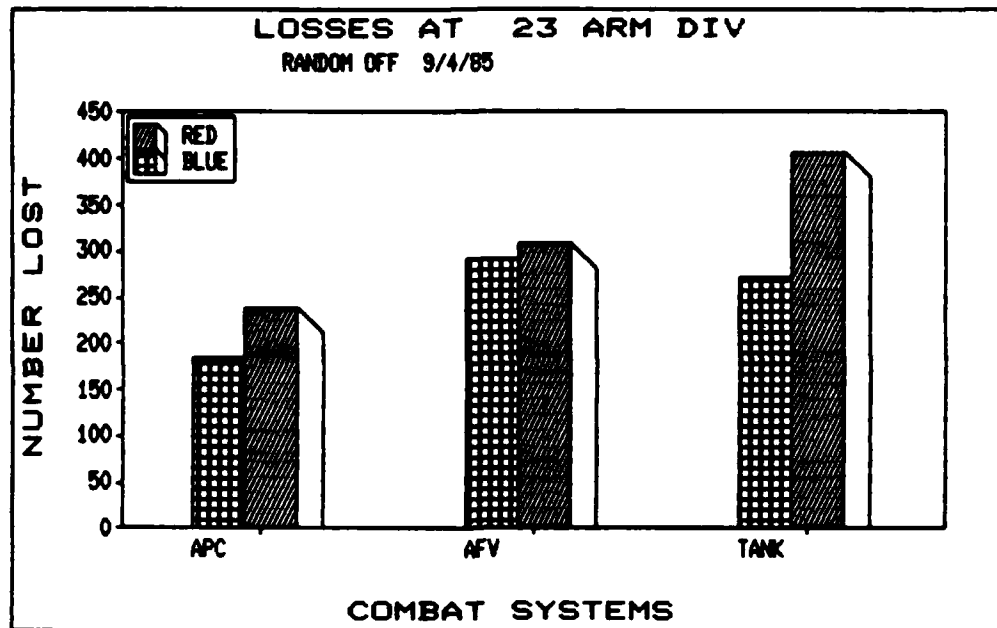

Figure II-12b. SUMMARY GRAPHS OF LOSSES AT THE 23RD ARMORED DIVISION (BASE CASE)

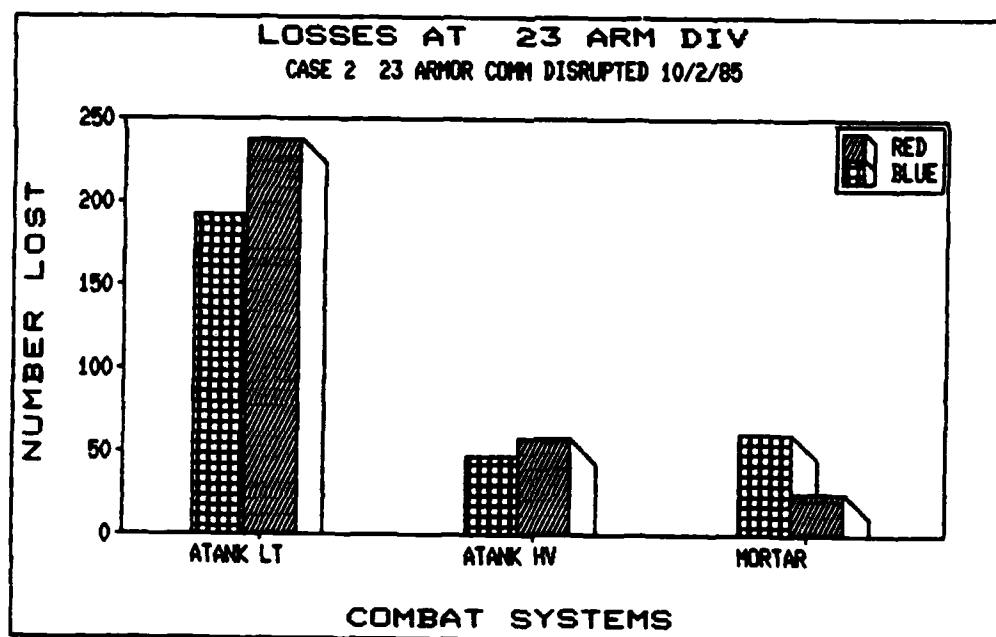
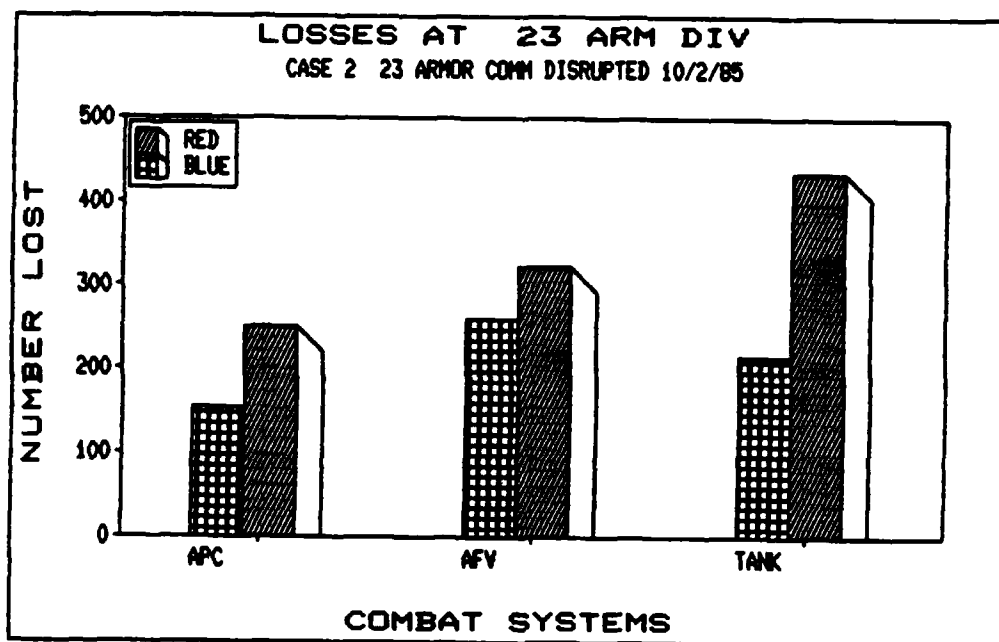

Figure II-13a. SUMMARY GRAPHS FOR LOSSES AT THE 23RD ARMORED DIVISION (CASE 2)

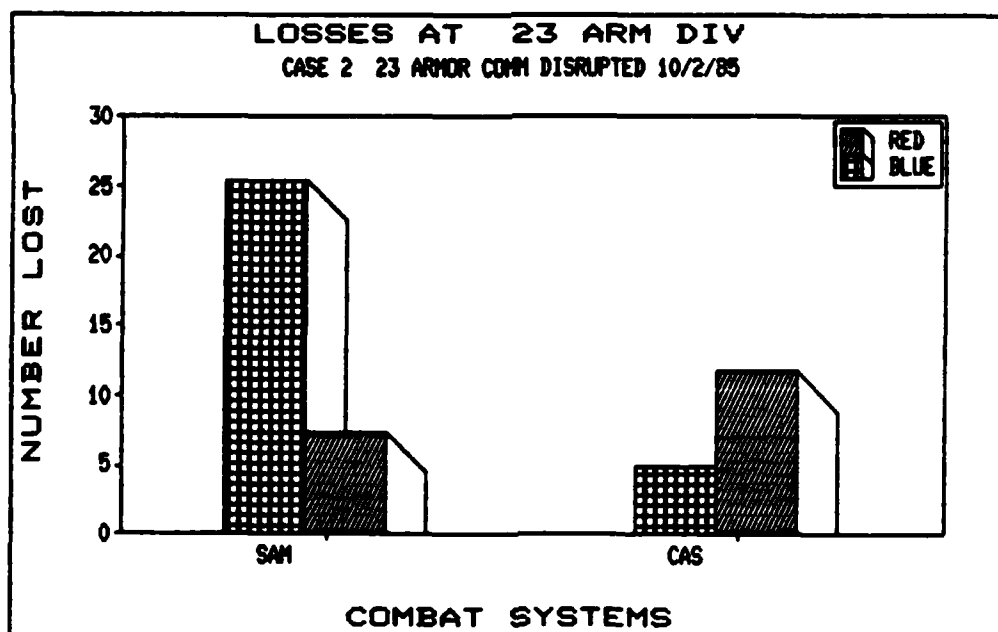
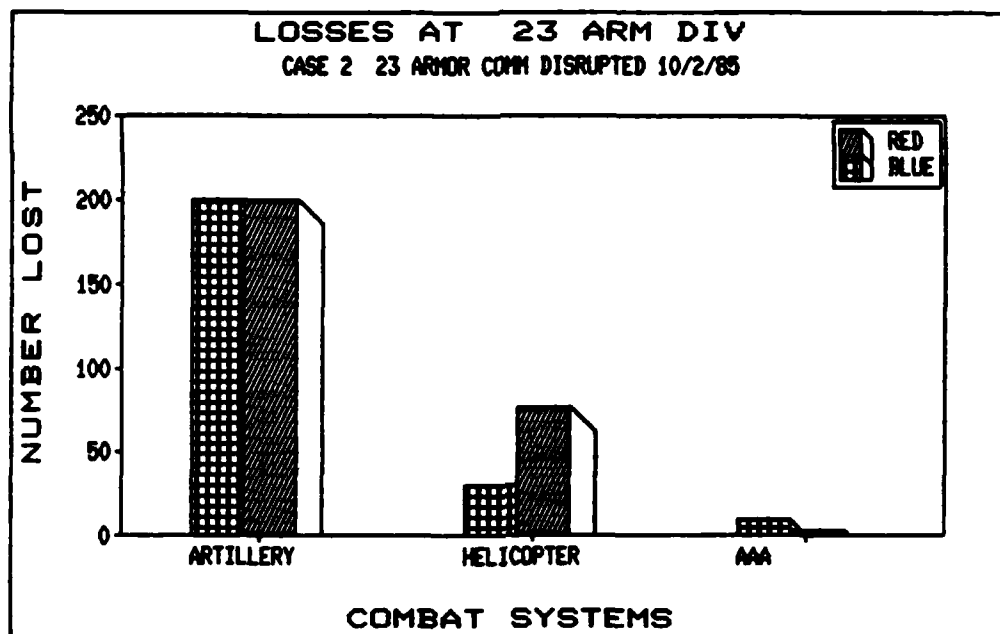

Figure II-13b. SUMMARY GRAPHS FOR LOSSES AT THE 23RD ARMORED DIVISION (CASE 2)

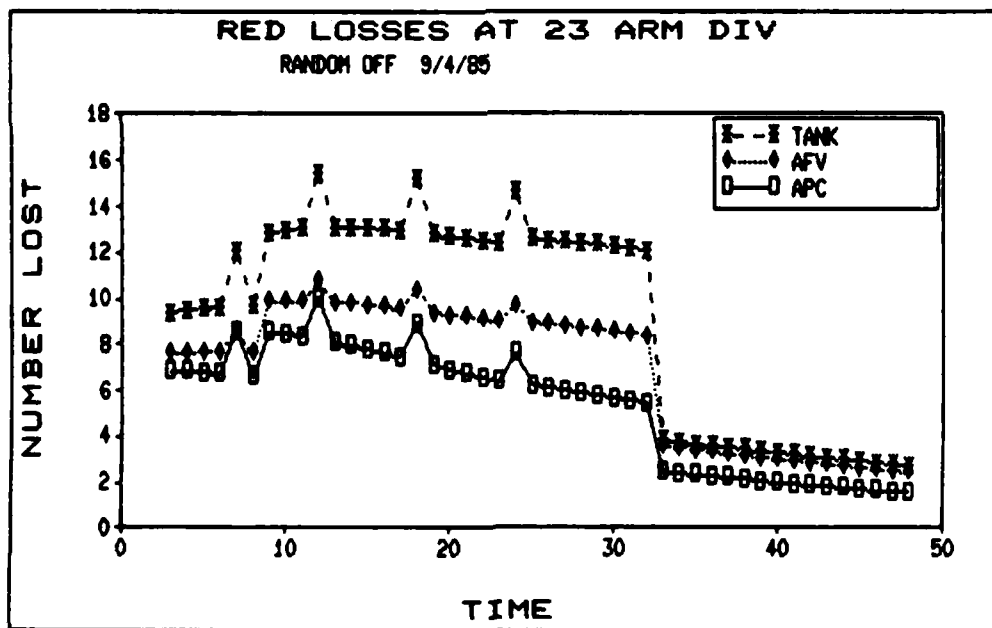
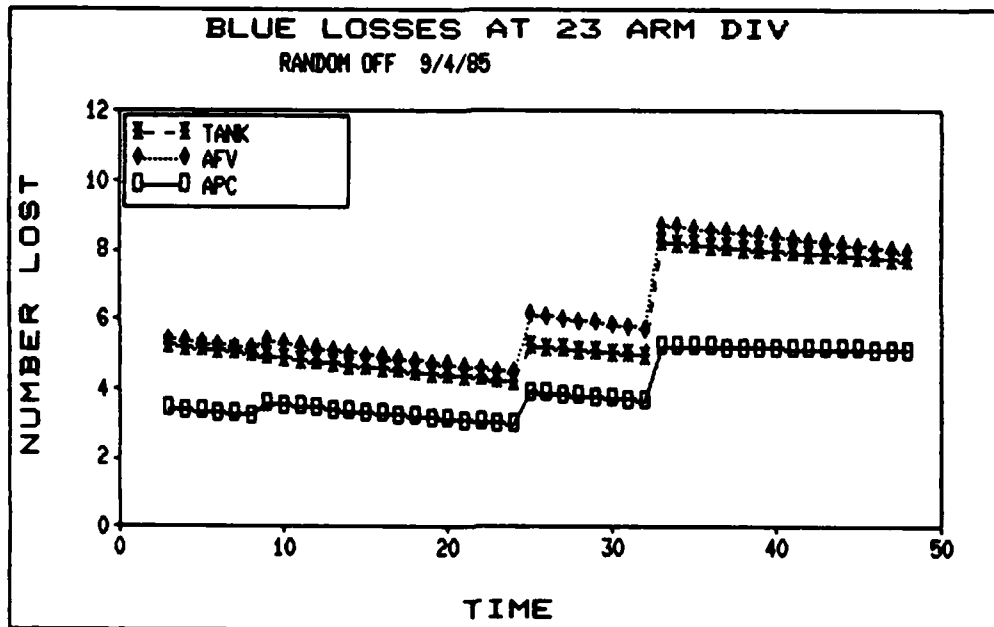

Figure II-14a. TIME T LOSSES FOR BLUE AND RED (BASE CASE) AT 23RD ARMORED DIVISION

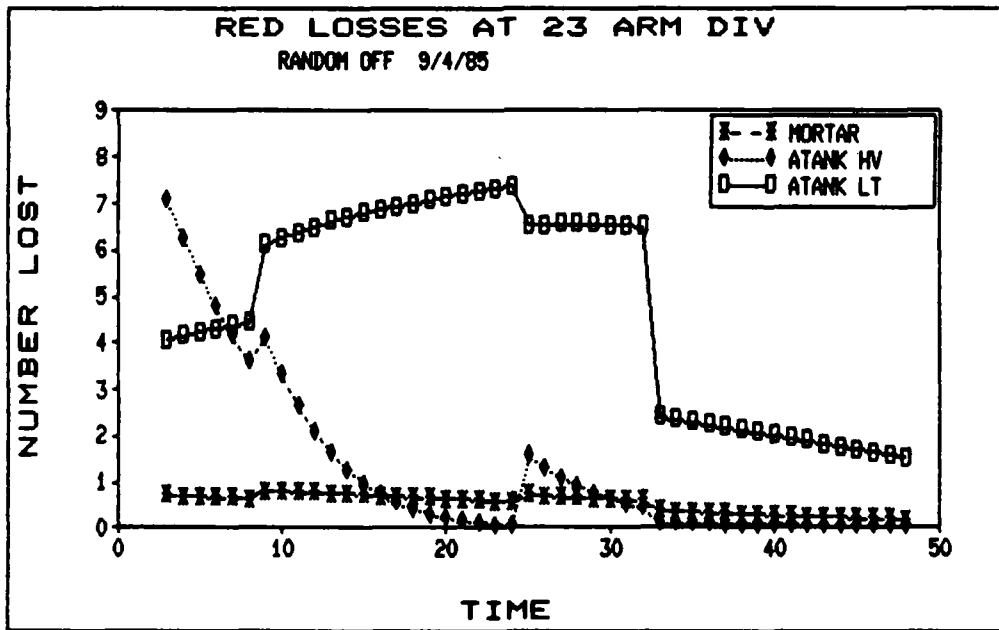
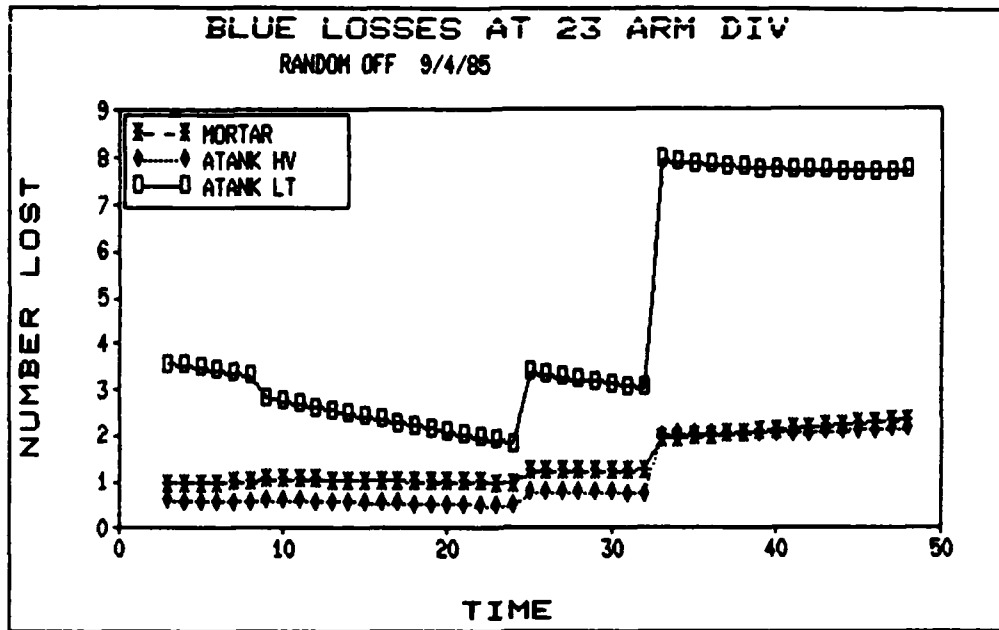

Figure II-14b. TIME T LOSSES FOR BLUE AND RED (BASE CASE) AT 23RD ARMORED DIVISION

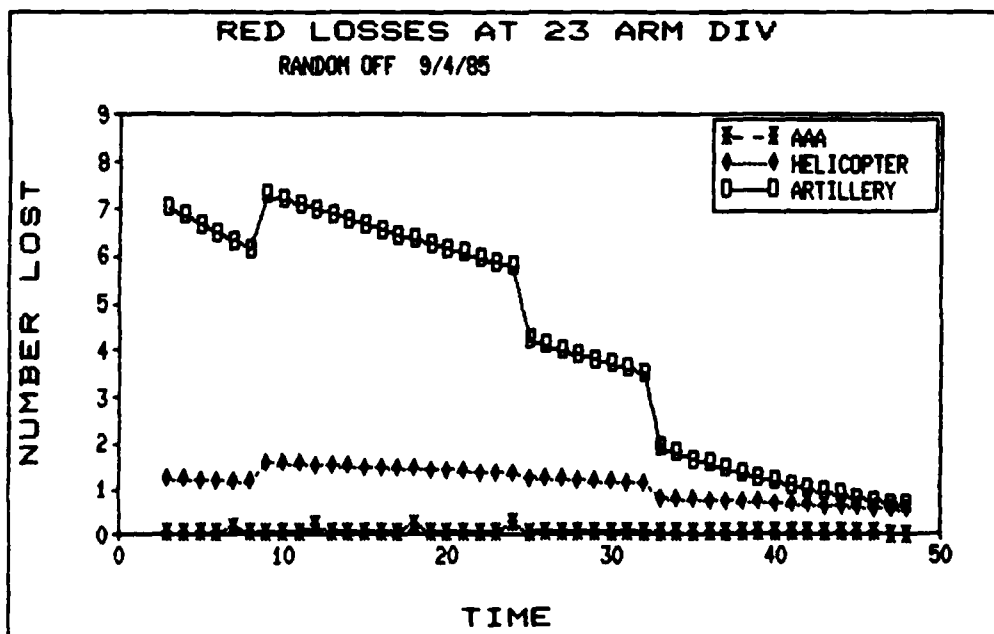
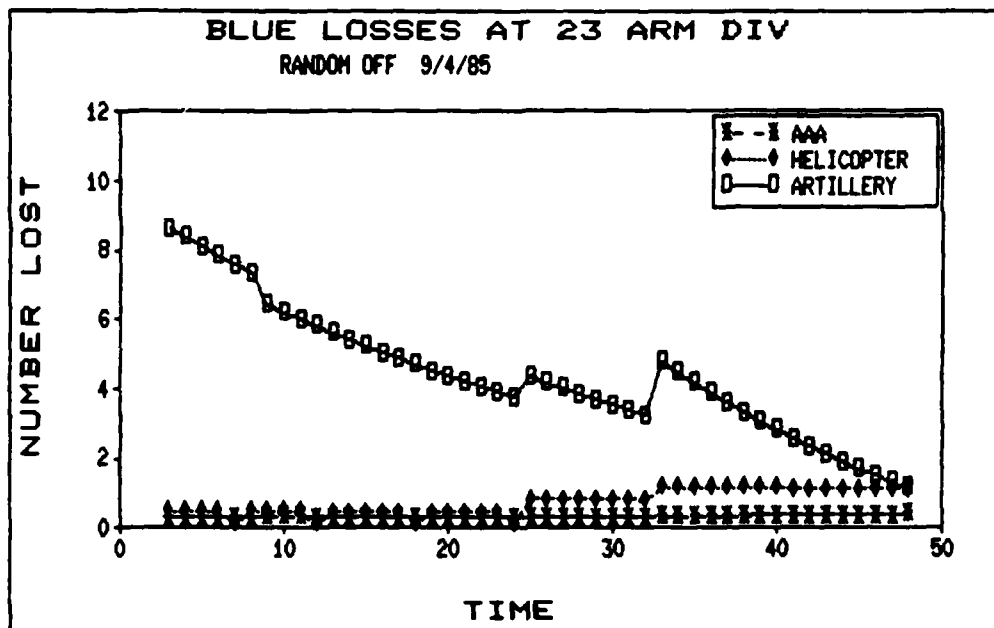

Figure II-14c. TIME T LOSSES FOR BLUE AND RED (BASE CASE) AT 23RD ARMORED DIVISION

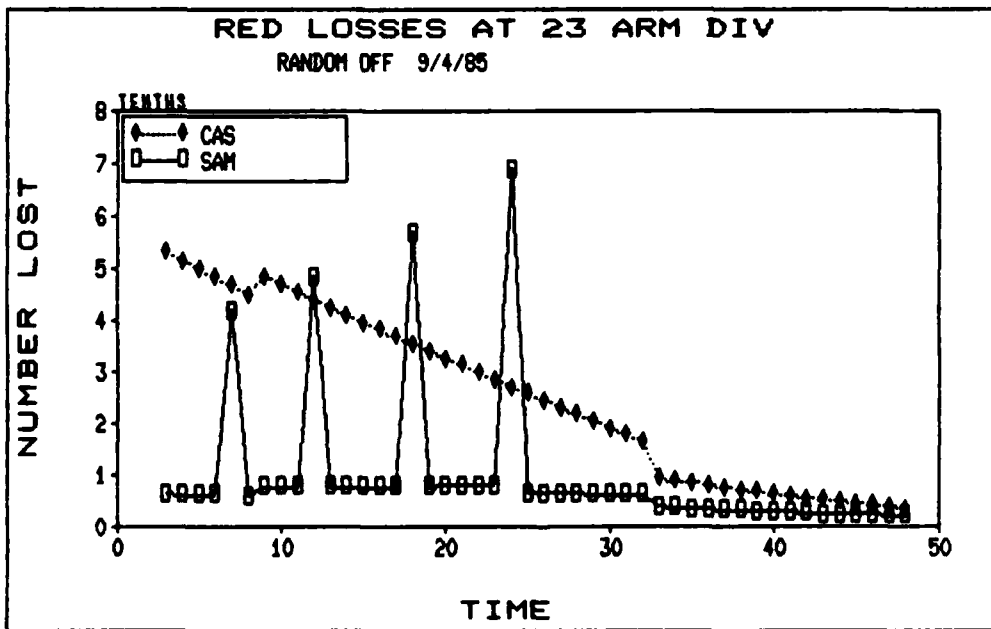
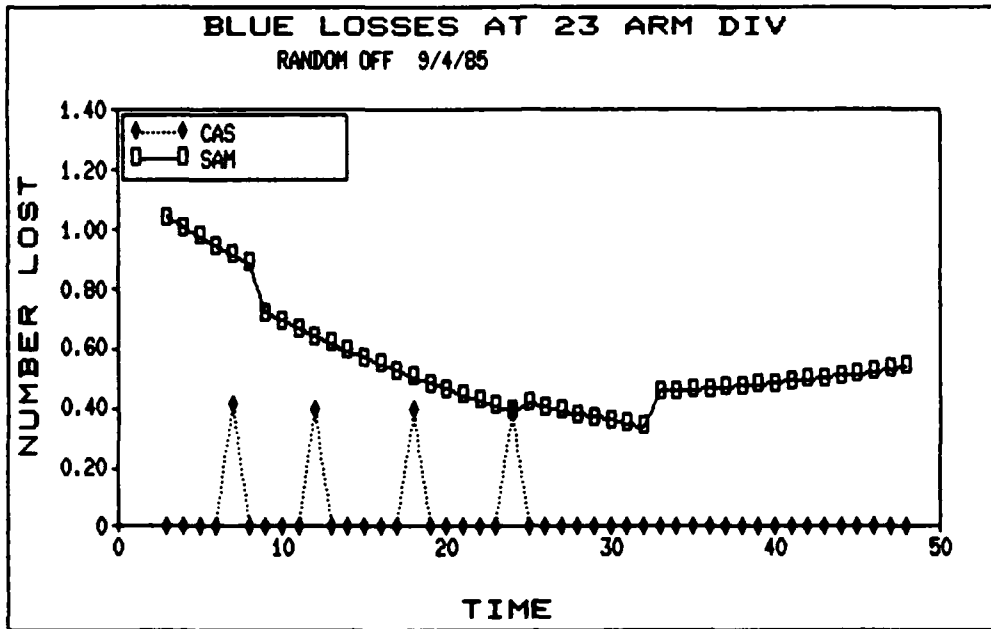

Figure II-14d. TIME T LOSSES FOR BLUE AND RED (BASE CASE) AT 23RD ARMORED DIVISION

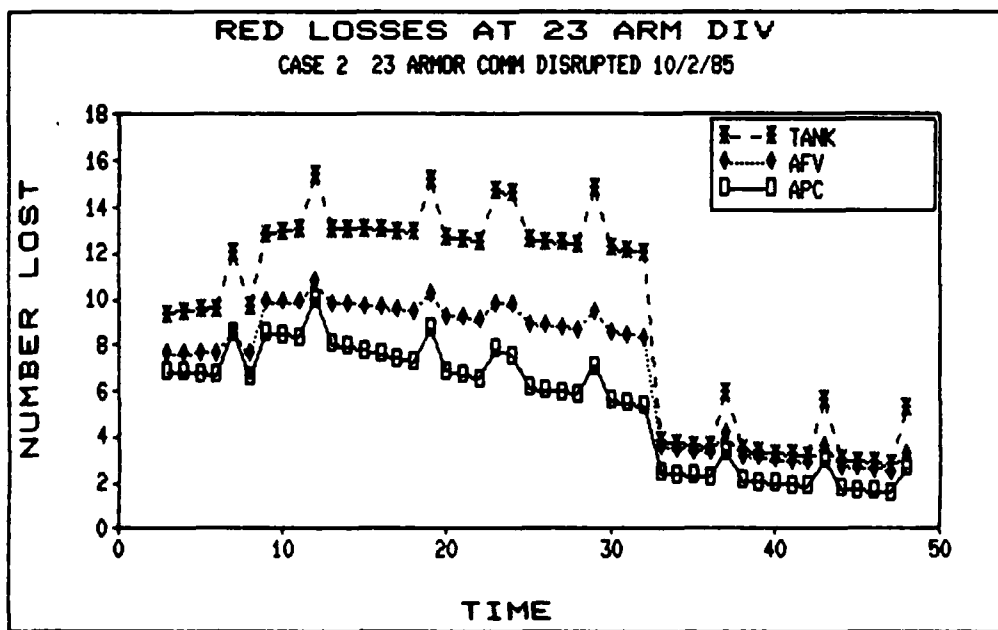
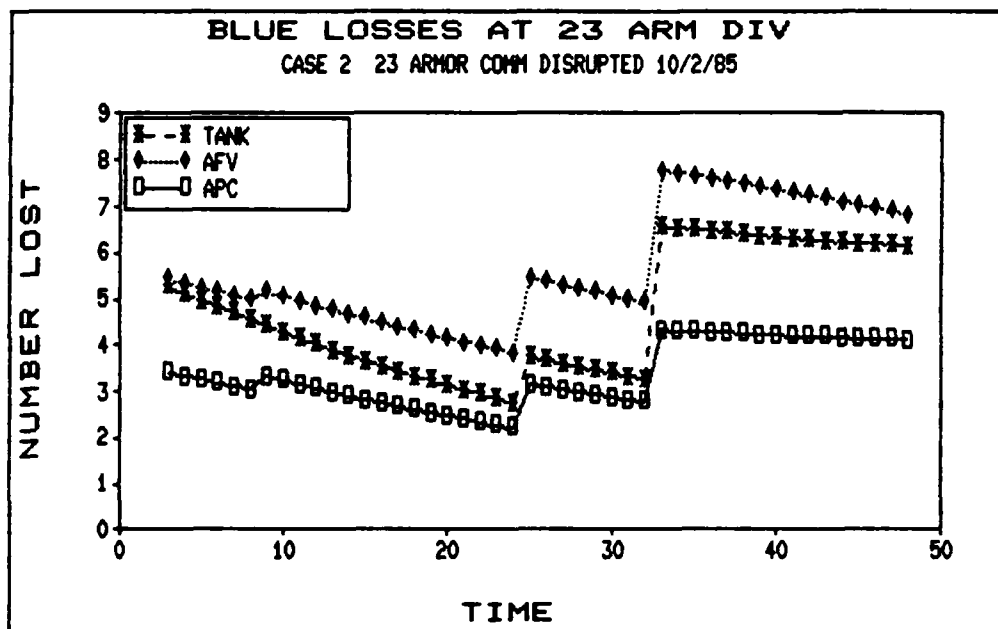

Figure II-15a. TIME T LOSSES FOR BLUE AND RED (CASE II) AT 23RD ARMORED DIVISION

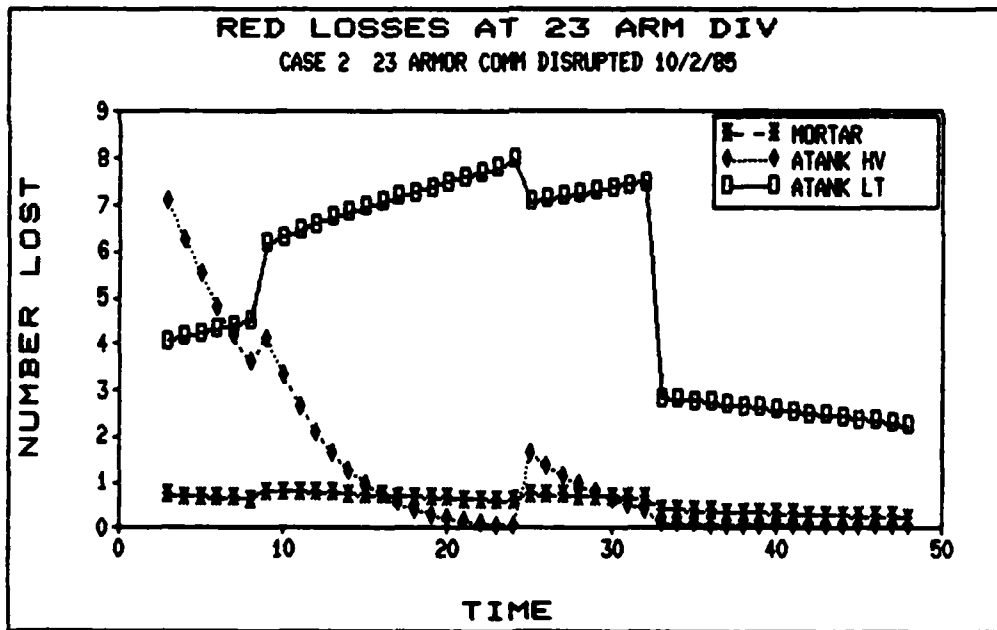
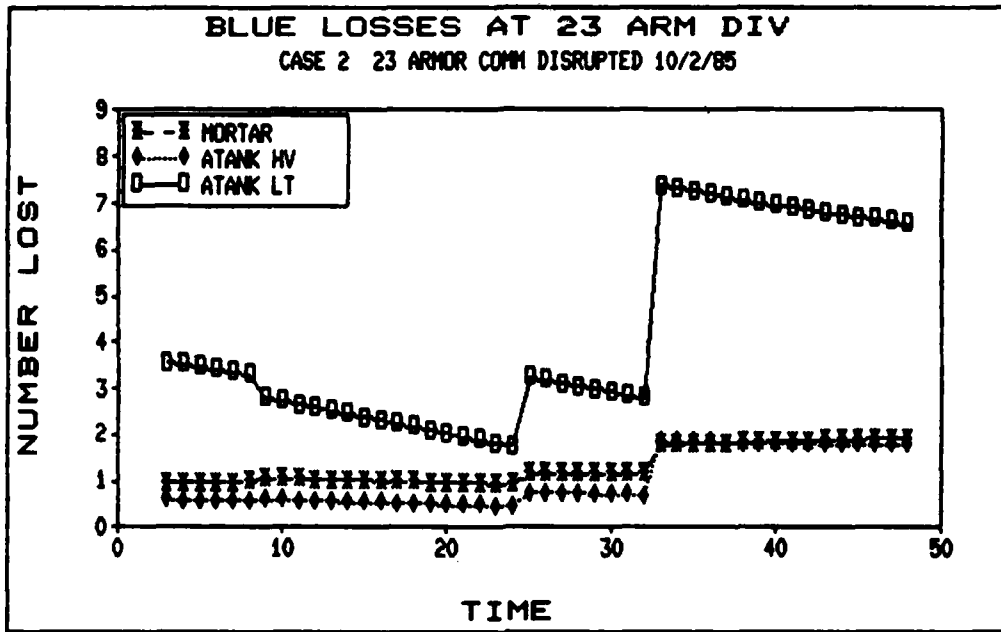

Figure II-15b. TIME T LOSSES FOR BLUE AND RED (CASE II) AT 23RD ARMORED DIVISION

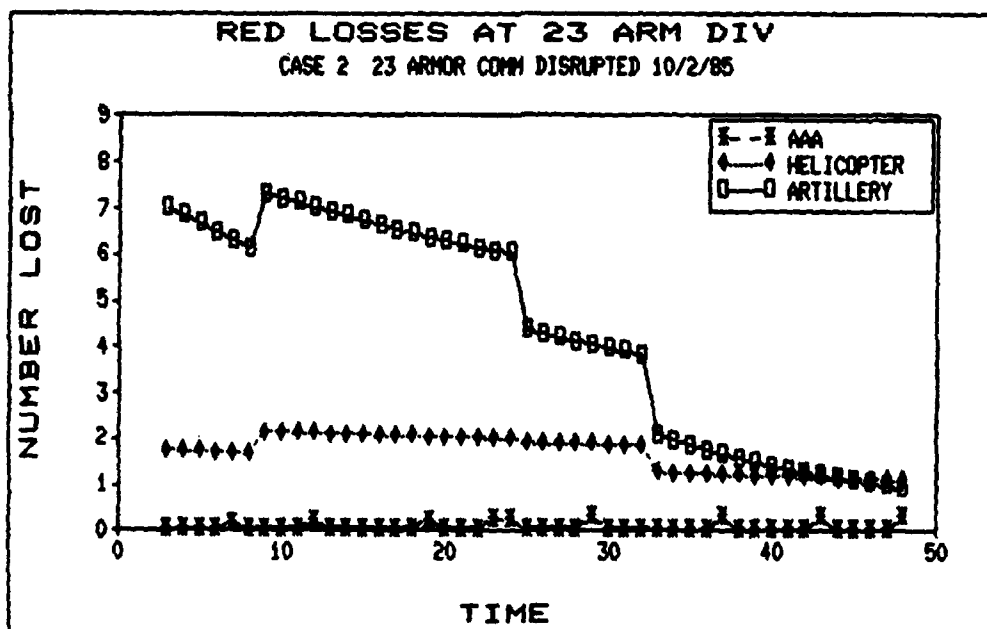
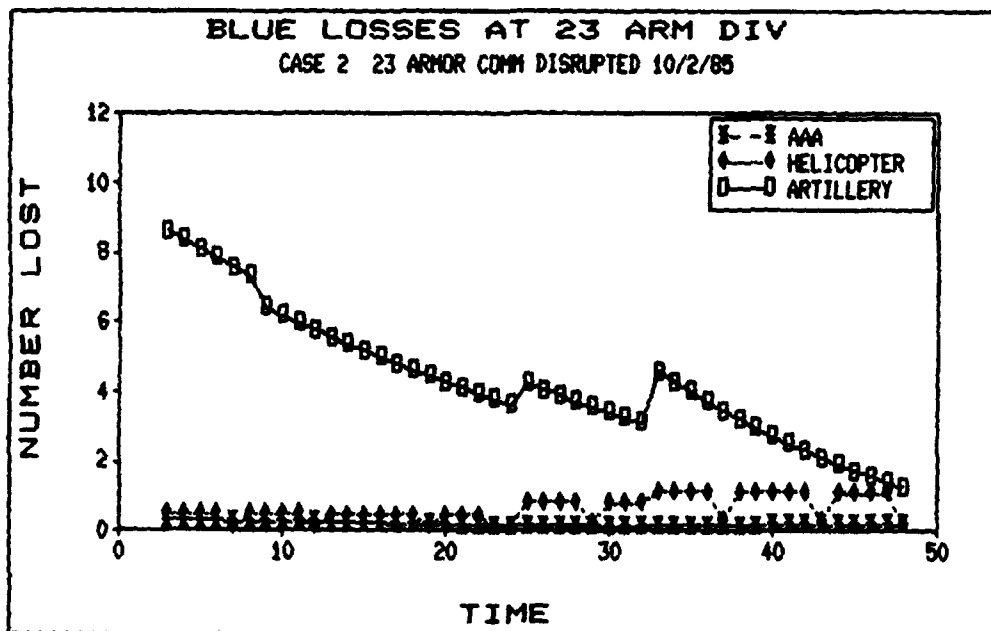

Figure II-15c. TIME T LOSSES FOR BLUE AND RED (CASE II)  
AT 23RD ARMORED DIVISION

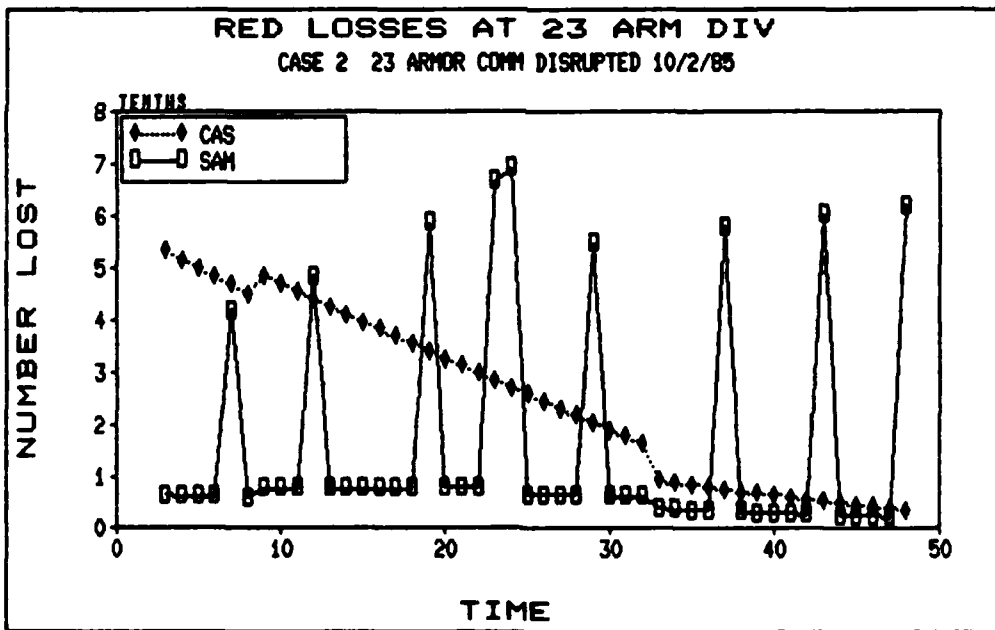
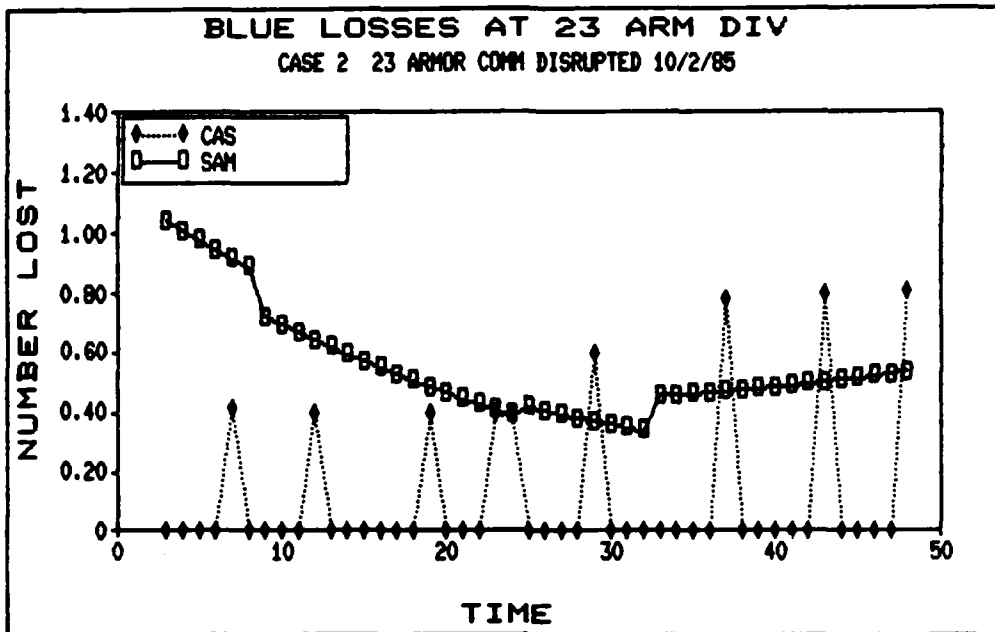

Figure II-15d. TIME T LOSSES FOR BLUE AND RED (CASE IV) AT 23RD ARMORED DIVISION

## F. ADDITIONS AND TESTS

In the discussion so far there have been descriptions of additions to the model that have been made during the current year. As a part of these additions and as a part of the continuing improvement of the model, there are other identifiable modifications. These include:

1) The identification of unit subordinates and commanders--this means that when units report to a commander at a higher command level the appropriate reports will always go to that commander. Similarly, when a commander is to receive certain reports from his subordinate commands, that unit will know the units that are subordinate to it.

2) Changes in postures, forces, path capacities, and units move in and out of combat as specified in the scenario or external messages.

3) Command post processing restructured to handle multiple message type processing and non-message type processing such as CAS allocation, helicopter allocation and the potential for other types of decision rules.

4) Enhanced decision rule sets.

5) Enhanced trace of events.

6) Input files increased for automatic responses to messages indications, for example, that a message has been received (echo), events, time T and summaries.

It was important to conduct an extensive test program to assure that the modifications operate as they were intended to operate and to eliminate bugs in the program. In the following, the nature of the test program is described by the major categories in which the testing was done.

a. COMMUNICATIONS NETWORK

Changes: The number of communications types between any two nodes in the data base was increased to four. The corps node was separated into main, tac and rear nodes, with the ASOC being colocated with Corps Tac. The division-level nodes were created as the combat-level units and nodes were added at Echelon Above Corps (EAC). The capacities of any path may be modified through the run.

<u>Tests</u>	<u>Results</u>
Path capacity set to zero and restored during run	Messages were transmitted on appropriate alternative communications types.
All path capacities from a division to Corp Tac set to zero	Messages were sent to appropriate alternates en route.
All path capacities to Corps Tac were set low	Messages to Corps Tac were delayed and deleted.

b. NODE OPERATIONS

Changes: Decision rules were input from file C<sup>3</sup>Rule. Input messages were limited. Output messages were limited. Node changes created commander's status of subordinates perceptions and the ability to approve CAS requests in accordance with allocation plan. It also created the commander's force ratio calculation for subordinates and modified air requests to reflect the processes for discrimination of preplanned and immediate request processing. New capabilities created commander's use of generic unit table of equipment for estimating TOE strengths.

TestsResults

Rules read from C <sup>3</sup> RULE	Echo of rules and node operation identical to previous runs.
Input limits set to zero	Messages held and/or deleted.
Input kill limit set less than hold limit	Kill limit set equal to hold limit.
Input more priority one messages than input limits	All priority one messages were accepted.
Output limits set to zero	Messages held and deleted.
Output kill limit set less than hold out limit	Kill limit set equal to hold Limit.
Created more priority one output messages than limits allow	Output held and killed correct number and priority messages.
Input enemies combat units	Unit names and strength of enemy in commander's status printout. Force ratio calculated and subordinate ordered accordingly
Unit loss reports created	Messages received by commander and strengths modified.
Communications paths limited	Commander's status of subordinates was updated late.
Allocation of CAS plan for preplanned sorties	Sorties allocated within plan.
Allocation of CAS plan for immediate sorties	Sorties allocated within plan.
Multiple CAS requests arrive at the same time at Corps Tac	Corps Tac adds requests together for allocated type and forwards individual requests for non-allocated type. Return messages contained correct number of sorties and correct number of sorties in combat matrix.
Requests for CAS exceed WOC's availability	All available aircraft sent, correct number scheduled later and dropped due to time limits.

c. TIME T INPUT

Changes: External messages, combat system strengths, combat unit postures, CAS allocation parameters, communication path limits, node input limits, node output limits and message type start times are available for input at Time T.

Tests

Results

Data sets created containing each input results

Time T values entered, echoed, stored internally and results modified accordingly.

d. OUTPUT ENHANCEMENTS

Changes: New output data created include new rule printout, limits printout, modified message tracking on on events file, selected data from CAS requests, commander's perceptions, CAS scheduling data, data set preambles and summary data of message flows and combat support. Some of these changes required some data structure modifications.

Tests

Results

Each new output element was activated by a data set developed to determine its correctness

Output data cross-checked with debug values created during the run and manual determination of result. Internal data structures were checked with debug operating. Summary data was compared to event data for accuracy and completeness.

e. RANDOM PROCESSES

Changes: Random effects were included for modification of values in combat loss reports, scheduling of force ratio generated CAS request messages, delay of messages to be sent by divisions and creation of messages in response to combat operations. All random effects are selected by a single-

user flag.

Tests

Results

Operation of random flag

All random operations were operating when flag was on and none operated with it off.

Combat loss values

All system losses at a given time and combat side were modified by the same random number and the random number was always within its distribution limits.

Force ratio generated  
CAS request

Creation of the requests were at the correct time (first time the ratio met the limit) and the random delays of the messages were within the desired distribution.

Delay of messages

The messages indicated at the division were delayed in accordance with their distributions.

Event messages

All messages indicated as random occurrences were created with times in accordance with their distributions.

**G. PREPROCESSOR DEVELOPMENT**

Changes: The menu functions of exit, instructions, preamble, simulation control, node dictionary and node were developed to operate in create and edit modes.

Tests

Results

Create Time T file

The contents of the file were printed and compared to the data in the events file.

Create Loss T file

This file is binary. A special program was written to print the contents. This printout was compared to the data in the events and Time T files.

Time T graphs

The data on the graphs created by this test were compared to the Time T and events files.

Summary graphs

The data on the graphs created by this test were compared to the printout of the Loss T and events files.

### III. DATA

#### A. INTRODUCTION

In this chapter some of the major data inputs to the model will be discussed. These are not in the order of the data input menu. The first of these data categories is the development of rules for the nodes. The rules are central to the operation of the C<sup>3</sup>EVAL model. The next section will briefly examine the assumptions made and the data used for establishing the capacities of the communications paths. The final section of this chapter discusses combat data briefly.

#### B. DEVELOPMENT OF DECISION RULES FOR C<sup>3</sup>EVAL

Decision rules represent the processes that occur in command posts (nodes) in the C<sup>3</sup>EVAL model. Each decision rule has three parts: the rule parameters, the data required for the rule to be invoked and the guidelines for the results of the rule.

Rules are assigned rule numbers to allow cross reference between the parts and used internally by the model to integrate message data segments with the appropriate rule when it is processed. Each rule is applied to a set of nodes in the scenario by assigning all nodes in the set a node type number and assigning that number as the process originator type in the rule parameters. Similarly, the required data (Message In) and results data (Message Out) data sets identify the originator and destination nodes using the node type as a key element. Setting up the decision rule file to provide continuity for node type, rule number, message-in type, message-out type and communications paths can appear to be a formidable task. This section presents a three-step approach to solving this problem.

1. Establish a node-type numbering scheme. This is generally based on the echelon of the units that will be represented by nodes. For the example, the following numbering scheme was used. (Note that ground units were assigned a three-digit number and air units were assigned four digits.)

250 Regiment  
300 Division  
400 Corps Main  
450 Corps Tac  
490 Corps Rear  
500 CENTAG  
600 AFCENT/AAFCE  
700 SHAPE  
5000 ATOC  
6000 4ATAF  
7000 WOC (WOC assignment required by code.)

2. Select from the list of general message types that are to be modeled (intelligence reports, casualty reports, request for CAS, etc.) one type and identify the first node type in the sequence of reporting in the network. Enter the node type number in the chart such as shown in Figure III-1 first node box and identify the source to initiate a report. (The alternatives are external message, periodic, random and combat generated.) Enter the initiation type and the destinations for this process at the first node type as shown in Figure III-1. Select each destination and repeat the process using the output from the previous node type in lieu of initialization. Repeat the process until all nodes that use the initial message or any of its siblings have been entered. Figure III-1 shows CAS re-quests that are generated by combat at regiment type nodes create output to Corps Tac nodes which output approved requests to the WOC. Next add rule numbers and message numbers as shown in Figure III-2. The rule number is the top number in the box and the node type is the lower number. The output message number is placed on the arrow.

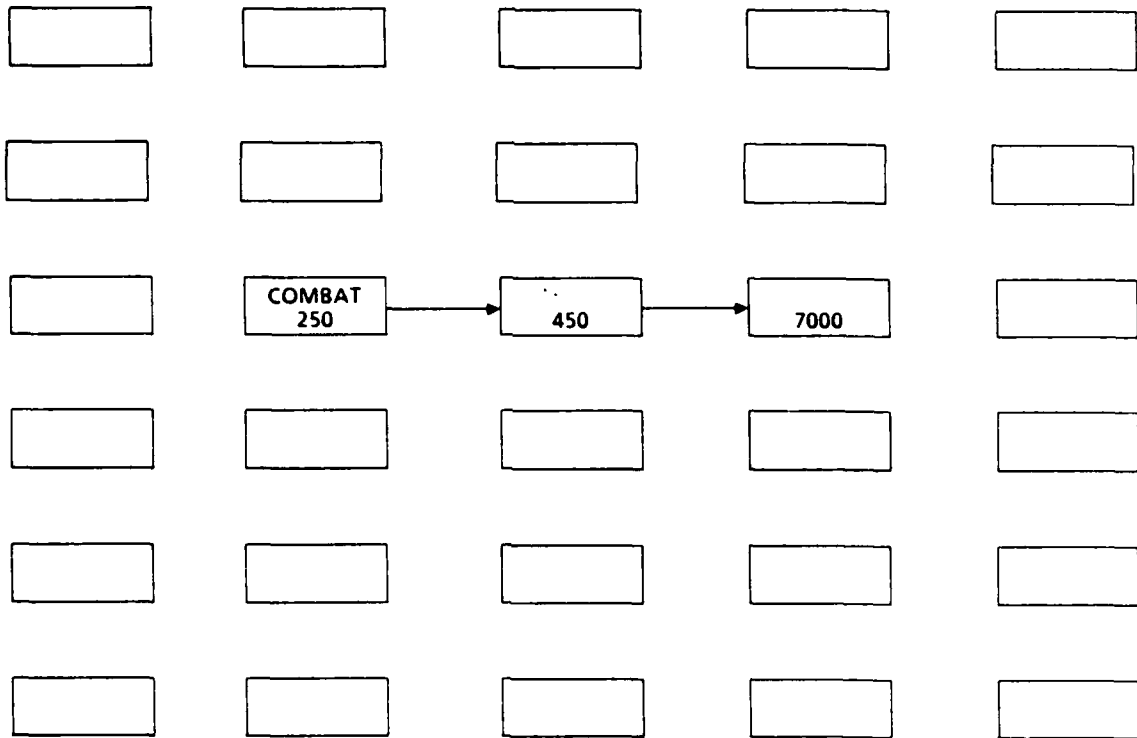

Figure III-1. IMMEDIATE REQUEST FOR CAS NODE NUMBERS

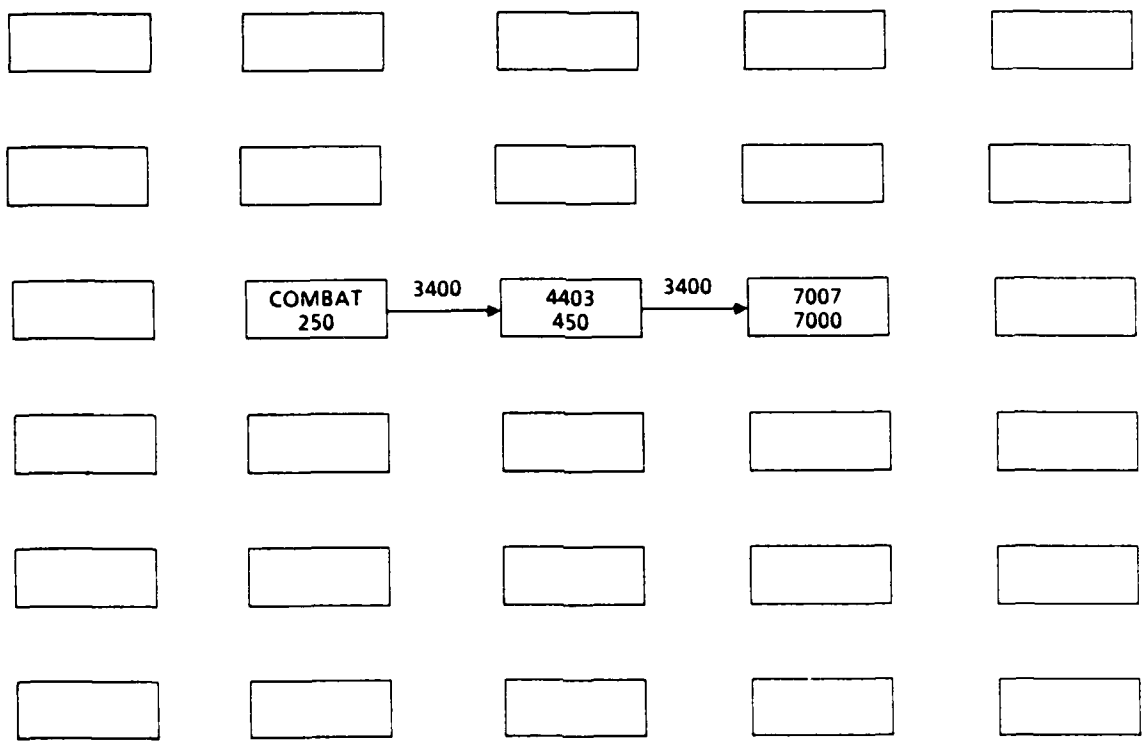

Figure III-2. RULE NUMBERS AND MESSAGE NUMBERS FOR IMMEDIATE REQUEST FOR CAS

This step normally is not the final result. In this case, it is necessary also to handle immediate requests generated by combat by division-type nodes as well as preplanned (by external messages) for the regiments and divisions. All of the approved requests are to be treated the same (same rule) at the WOC, so process 7007 brings all of these together. It is also helpful to note that the WOC is the node for AIROPS which provides sorties as available. The AIROPS process then sends return messages (number 7000) back through the network to the requesting unit which has special processes to delete the data content portion of the message. This is represented in Figure III-3, which has expanded the original regiment immediate requests to the overall flow of CAS messages. Figure III-3 also shows that preplanned sorties (3000) are passed to the ATOC and then to the 4ATAF, etc., while immediate request notifications are sent via CENTAG to EAC. The absence of process numbers at 500 and 700 nodes indicate that the 3200 and 3401 messages will go through the network to the node and through the input limits, but will not initiate a process at these nodes.

3. The final step is to convert Figure III-3 into computer input form. This is facilitated by using the Rule, Input and Output forms in Figures III-4, III-5 and III-6. Figures III-7, III-8 and III-9 show the completion of these forms for the Corps Tac node.

### C. COMMUNICATION PATH CAPACITIES

The user may choose the number and types of communications paths. The capacities of these paths may be specified in numbers of different rates. The first number generally encountered is the bit rate or the bits per second. In many cases, however, the capacity available for sending particular types of messages will be less than that permitted by the maximum data rate. An example of this is the use of a digital channel for transmitting voice. The transmission of teletype with no storage before transmission means that the transmission rate will be established by the typing rate. These

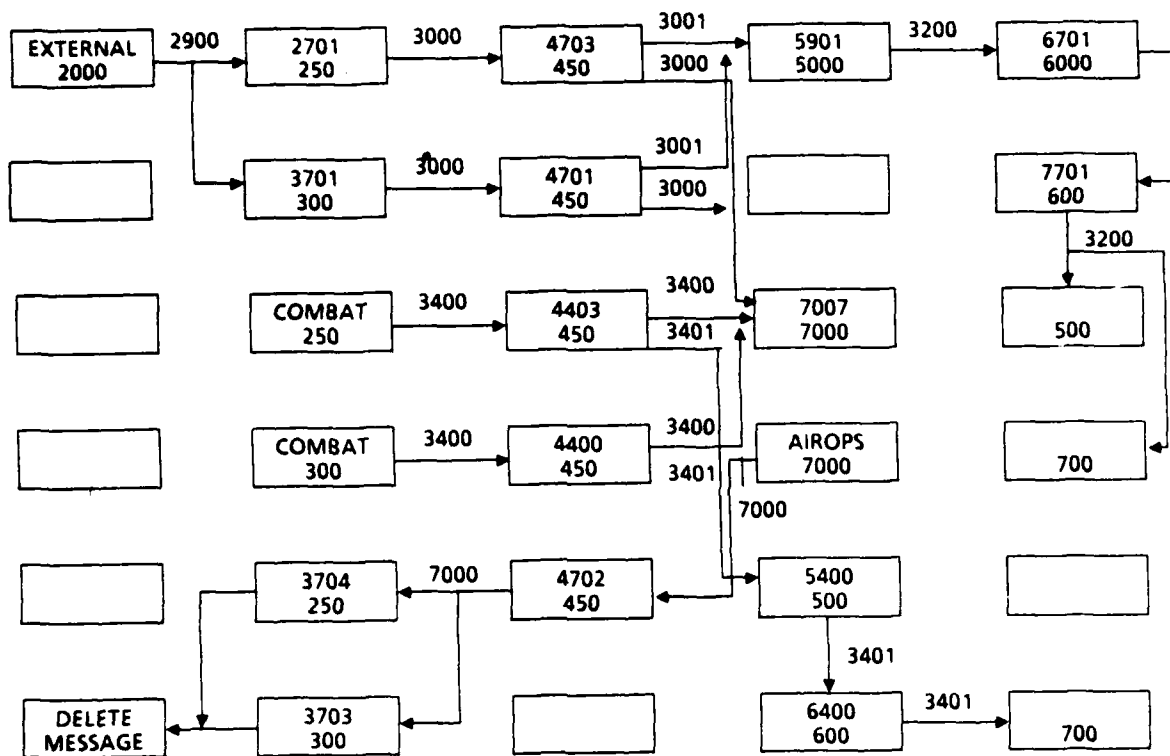

Figure III-3. CAS MESSAGES, GENERAL PROCESS TITLE

RNO	O TYPE	TIME	MIN	FLAG	COMMENT

Figure III-4. RULE DATA FORM

RNO	ITYPE	MSG	AGE	USE	COMMENT

Figure III-5. INPUT MESSAGES REQUIRED TO INITIALIZE

NO	DTYPE	MSG	PRI	LINK	CAP	LINK	CAP	LINK	CAP	C	O	ALT 2	ALT 3	A	COMMENT

Figure III-6. OUTPUT MESSAGES BASED ON DECISION RULES

RNO	O TYPE	TIME	MIN	FLAG	COMMENT
4703	450	1	1	0	ASOC IAR
4701	450	1	1	0	ASOC IAR
4403	450	1	1	0	CORPS AIR
4400	450	1	1	0	CORPS AIR
4702	450	1	1	0	ASOC IAS

Figure III-7. RULE DATA CAS MESSAGES AT CORPS

RNO	ITYPE	MSG	AGE	USE	COMMENT
4703	250	3000	2	0	IAR
4701	300	3000	2	0	IAR
4403	250	3400	2	0	IAR
4400	300	3400	2	0	IAR
4702	7000	7000	2	0	IAS

Figure III-8. INPUT MESSAGES REQUIRED TO INITIALIZE

NO	DTYPE	MSG	PRI	LINK	CAP	LINK	CAP	LINK	CAP	C	O	ALT 2	ALT 3	A	COMMENT
4703	5000	3001	1	3	500	1	500	2	500	0	1	7000	450	2	IAR
4703	7000	3000	1	2	500	1	500	3	500	0	1	5000	450	2	IAR
4701	5000	3001	1	3	500	1	500	2	500	0	1	7000	450	2	IAR
4701	7000	3000	1	2	500	1	500	3	500	0	1	5000	450	2	IAR
4403	7000	3400	1	3	1500	1	1500	0	0	0	1	0	0	1	IAR
4403	500	3401	3	3	1500	1	1500	0	0	0	1	0	0	1	IAR
4400	7000	3400	1	3	500	1	500	0	0	0	1	0	0	1	IAR
4400	500	3401	3	3	500	1	500	0	0	0	1	0	0	1	IAR
4702	250	7000	3	3	500	2	500	0	0	0	1	400	300	4	IAS
4702	300	7000	3	3	500	2	500	0	0	0	1	400	300	4	IAS

Figure III-9. EXAMPLE OF OUTPUT MESSAGES

modifications must be considered when specifying path capacities.

For purposes of the model, the path capacities are expressed in characters, and it is assumed that there are eight bits per character. The model does not require that characters be used, but it is essential that both path capacity and message length are expressed in the same units. Since the time interval chosen for the model application is one-half hour, the capacity is necessarily defined as characters/one-half hour or characters/time interval. Based on the scenario chosen and the data available from US Army and US Air Force sources, the basic capacities for internodal US paths are:

Voice	9,000 characters/one-half hour				
TTY	17,000	"	"	"	"
Data rate (Army)	$3.6 \times 10^6$	"	"	"	"
Data rate (AF)	$1.8 \times 10^6$	"	"	"	"

Army encrypted data rate is the same as that specified for the Air Force. When NATO or German national paths are used, the capacities must be separately determined for those paths.

In the selection of capacities for the paths, the assumption has been made that when there is a statement as to the resources available in the doctrine, this will be the capacity available. The representation, for example, of division communications is a doctrinal system based on US Army Field Manual FM 11-50, "Combat Communications Within the Division." This means that the data will not exactly reflect the division capabilities in the 5th Corps area since the actual communications are tailored to the specific division. The doctrine specifies the number of paths available for the Commander, Operations and Intelligence, for example, and indicates whether they are dedicated voice, TTY or other. Standard practice for the use of multichannel paths is also specified.

At corps the doctrinal capacities are also used. The scenario specifies that TRITAC equipment is available. The scenario also specifies the netting of the communications within the corps and the major paths to NATO commands. The paths for the model are determined primarily from the doctrine that indicates the paths available and their type for Commander, Operations and Intelligence. This means that paths available, for example, from the German Postal Telephone and Telegraph (PTT) are not specified.

Air Force communications paths were determined from Tactical Air Force Interoperability Group (TAFIG) documents. Path capacities were established primarily on the basis of the connections made with the specified nodes in the TAFIG documents. These are the available documented capacities and not necessarily those that are actually in use with US forces in Central Europe.

When specifying the capacities available at the higher levels of command (4ATAF, CENTAG, AFCENT/AAFCE and SHAPE), reference was made to available documentation. The capacities are best estimates assuming that the nodes are the wartime locations. It is appreciated that many of the communications paths are netted and no specific allowance has been made for this in the data currently in the model. In order to establish the characteristics of the nets that are being used, a separate network model should be used to determine the necessary values for the aggregated paths used in C<sup>3</sup>EVAL and for the degradation capacities to be used when wartime damage is to be postulated in the scenario. If verification is desired of the assumptions made about the paths that are available, contact should be made directly with the appropriate commands in Europe.

#### **D. COMBAT DATA**

The remaining data set that is to be considered in this report is the combat data. For purposes of the development of the model

undertaken, the units identified are fictitious. Generic data is used for equipment in the units that appear. These data are available from unclassified sources. The data used for rates of fire, allocations of fire and probabilities of kill are also unclassified.

## IV. FUTURE DEVELOPMENT

### A. INTRODUCTION

The final chapter of this report presents some suggestions for the further development of the model. The suggestions made here are logical extensions of the work that has been done. It should be noted that the total of the work suggested is appreciably greater than that which could be done at the current level of effort.

The first of the suggestions is the addition of logistics to the current model and the requirements for the addition of nuclear command and control. Possible additions to the command nodes and alternate scenarios is considered in Section C. Treatment of additions to other forces and force activities are examined. Finally, program improvements and additions to the pre- and post-processors are considered.

### B. LOGISTICS AND NUCLEAR

These two representations are considered together since there are some important similarities. In both cases, the recommendations are for structure within the U.S. area and the NATO control immediately above that. The features that would be added for logistics are as follows:

**NODES:** USEUCOM/USAREUR, USAFE and an aggregated supply node. These additions are required since logistics is a national responsibility.

**COMMUNICATIONS PATHS:** Additional paths connecting corps, division, CENTAG, USEUCOM/USAREUS, USAFE, WOC, ATOC 4ATAF, AFCENT/AAFCE and supply depot including specially denoted logistics paths.

**ACTION MODE:** Modification to include maintenance of supply level at division. The rate of consumption of supplies is proportional to the posture or intensity of combat. Combat capability will be reduced as supply levels are reduced below specified amounts. The primary records will be of ammunition and POL requirements. Resupply rate of the supply point would be degraded if the node is attacked.

**RULES:** At division, thresholds will be set that will trigger requests for supplies at appropriate points. At corps level requests for supplies will be approved/disapproved. Messages and the appropriate rules for logistics will be added. The existing rule/message structure will be modified where existing messages are also sent to USEUCOM/USAREUR and USAFE. Appropriate delays in the arrival of supplies from depots will be required. Reductions in node C<sup>2</sup> capability would be represented with the existing input and output limiters.

**ESTIMATED WORKMONTHS (WM):** 6

**ADDITIONAL POSSIBILITIES:** It may be desired to consider separate supply nodes for Army and Air Force (e.g., Kaiserslautern and Morbach), a corps supply node, and a "port." If the supplies are to be interdicted, there must be an interaction with an air operations model that does not now exist. These additions would require additional manmonths.

The features for nuclear C<sup>3</sup> are as follows assuming logistics has been done:

**NODES:** USEUCOM/USAREUR, USAFE and an aggregated Special ammunition Supply Point (SASP).

**COMMUNICATIONS PATHS:** Additional paths connecting corps, division, CENTAG, USEUCOM/USAREUR, USAFE, WOC, ATOC, 4ATAF, AFCENT/AAFCE and the SASP. The paths would include specially denoted paths for national and NATO nuclear communications as specified.

**ACTION MODELS:** The effects of the use of nuclear weapons on ground combat units would be represented by a percentage attrition of the unit equipment.

RULES: The periodic and special messages and the rules for their processing would be added. It is assumed that nuclear events would be as scenario outputs.

ESTIMATED WORK MONTHS: 4

It can be seen that the nuclear addition has significant overlap with logistics in the nodes that are added. If the logistics component has been installed and is operating, then the manpower requirement to add nuclear processes will be somewhat reduced. It is recommended that the logistics be added first.

### C. COMMAND NODE AND SCENARIO EXTENSION

The first addition considered in this section is a natural extension of the existing model. The additions include the completion of the headquarters and division/ACR nodes for VII Corps and corps controlled helicopter operations. As a part of this extension, the re-allocation decision structure would be extended to the higher levels of command. The additions would be as follows:

NODES: VII Corps, divisions/ACR and a helicopter airfield.

COMMUNICATIONS PATHS: Those required by the addition of VII Corps. It may be desirable to add specially designated communications paths above those presently included. Communications for helicopter operations would be required.

ACTION MODELS: The requirement would be for the data for the VII Corps units and the operation of helicopters as with CAS/BAI aircraft.

RULES: Modify the CENTAG rule system for re-allocation approval/disapproval. CENTAG will also make comparisons of force needs on the basis of information received from subordinate commands, i.e., reports of attrition suffered by Blue and Red. Reallocation would specifically include the approval/disapproval of air resources from one corps to another. Helicopter operations would require addition to the rules at corps to include these resources as a part of the reallocation process.

ESTIMATED WORK MONTHS: 6

A major addition would be the inclusion of a more complete representation of air operations. The processes for assignments to specific missions and the use of multipurpose aircraft for alternative missions would require the inclusion of additional types of aircraft in addition to the two types currently included. The addition of types is in itself not difficult, but the additional rules structure would be more complex. The needs for representing air operations more completely are as follows:

**NODES:** Disaggregate the WOC to include three WOC nodes and an Air Defense Operations Center (ADOC).

**COMMUNICATIONS PATHS:** Paths to WOCs and ADOC with other Air Force nodes and with Army operations as required. It is suggested that the CRC continue to be represented in the same node as the ATOC or ADOC. A node for control of ground-to-air defense operations would be added.

**ACTION MODELS:** A representation of the air battle in the air defense of friendly territory would be included. Accounting for losses to ground-to-air defenses would be necessary. Reconnaissance missions could supply intelligence inputs to the system. Interdiction and offensive counterair missions would require accounting for attrition suffered, but would be treated as a specified number of time intervals during which the aircraft performed their specified missions. Attrition would be a percentage of the aircraft on the mission, although randomness may be introduced into this calculation. Airbase operations would be degraded if the airbase is attacked by a reduction in the sortie generation rate. Interdiction by Red air forces of logistics or nuclear supplies would require degradation of response time and loss of supplies.

ESTIMATED WORK MONTHS: 10

Other additions or modifications are possible that range from rather small changes to a setup for a different command structure and scenario situation such as PACCOM environment. If the rules and

structure are to be used extensively in evaluating C<sup>3</sup>, there should be an attempt made to verify with people in the theater.

#### D. ADDITIONAL MODIFICATIONS

In addition to the addition of major operational representations to the model, there are a number of improvements that can be made. These range from process representations to improvements in the pre- and post-processors. They will be considered briefly in the following test.

1. ECHO: An automatic echo to the sender from the received to notify that a message has been received and hold original until received or sent again. (WM: 5).

2. RANDOM: Extend the random processes to include randomness in additional processes.

- Conversion of fraction killed to random draws for CAS and helicopters destroyed.

- Aircraft repair time.

- Weather operations at WOC or airfield (WM: 1).

3. CAS: Divert CAS/BAI sorties on way to target and modify force ratio calculation at division (WM: 2.5).

4. PREPROCESSOR: Add six items not completed on menu (WM: 3).

5. POSTPROCESSOR: Graphics to same scale with Red and Blue on same chart

- Base case and excursion on same chart.

- ATAF and CENTAG perceptions.

- Loss reports plotted as integers (WM: 2.5).

There are in addition a number of "clean-up" jobs to be done that will require about one work month of effort.

PROPOSED  
DISTRIBUTION  
IDA PAPER P-1882

C<sup>3</sup> EVAL MODEL DEVELOPMENT AND TEST  
Volume I  
Overview

75 Copies

Copies

DEPARTMENT OF DEFENSE

Office Joint Chiefs of Staff  
Washington, DC 20301-5000

ATTN: Dr. Robert Fallon, Office of Director, Command Control and Communications Systems	12
Dr. William G. Lese, JAD	1
LTC Joseph M. Cummings, USA, JAD	2
CPT W. L. Butler, USN, J-3	1
LTC J. P. Morrison, USAF, J-4	1
CDR T. R. Sheffield, USN, J-5	1
Directorate of Information and Resource Management	20

Office of the Under Secretary of Defense  
for Research and Engineering  
Room 3D139, The Pentagon  
Washington, DC 20301

ATTN: Mr. James Bain, C <sup>3</sup> I	1
--	---

Director  
Defense Intelligence Agency  
Washington, DC 20301-6111

ATTN: Mr. A. J. Straub, (Pompino Plaza 1023)	1
--	---

Office of the Secretary of Defense  
OUSDRE (DoD-IDA Management Office)  
1801 N. Beauregard Street  
Alexandria, VA 22311

ATTN: Col T. L. Ricketts	1
--------------------------	---

Defense Technical Information Center Cameron Station Alexandria, VA 22314	2
---	---

DEPARTMENT OF THE ARMY

Deputy Chief of Staff for Operations and Plans  
Room 3C542, The Pentagon  
Washington, DC 20310-0403

ATTN: Maj W. E. Ward, USA 1  
Mr. Hunter Woodall, DCS/RDA 1

DEPARTMENT OF THE NAVY

Chief of Naval Operations  
Department of the Navy  
Room 4E549, The Pentagon  
Washington, DC 20350

ATTN: CDR D. L. McKinney, USN NOP 1

Commander  
Naval Postgraduate School  
Monterey, CA 93940

ATTN: Prof Michael G. Sovereign, Chairman 2  
Command, Control and Communications

HQ, U. S. Marine Corps  
Columbia Pike and Arlington Ridge Road  
Arlington, VA 22204

ATTN: LTC T. L. Wilkerson, Office of the Deputy Chief of Staff 1  
Plans, Policy and Operations (MD-P)

Commander  
Naval Postgraduate School  
Monterey, CA 93940

ATTN: Prof Michael G. Sovereign 1  
Chairman, Command, Control and Communications

DEPARTMENT OF THE AIR FORCE

Deputy Chief of Staff, Operations, Plans & Readiness  
Department of the Air Force  
Washington, DC 20330

ATTN: LTC M. H. Long, AFXOX 2

CIVILIAN CONTRACTORS

Applications Research Corporation  
330 S. Ludlow Street  
Dayton, OH 45402

ATTN: Mr. Rodney B. Beach 1

Institute for Defense Analyses  
1801 N. Beauregard Street  
Alexandria, VA 22311

22

ATTN:	Gen W. Y. Smith	1
	Mr. S. J. Deitchman	1
	Mr. R. Pirie	1
	Mr. A. R. Barbeau	1
	Dr. William J. Schultis	1
	Dr. Harry Williams	1
	Mr. Robert F. Robinson	1
	Mr. Joseph W. Stahl	1
	Dr. J. Bracken	1
	Mr. J. L. Freeh	1
	Mr. E. Kerlin	1
	Mr. A. O. Kresse	1
	Dr. D. L. Ockerman	1
	Dr. E. S. Parkin	1
	Dr. F. R. Riddell	1
	Dr. V. A. Utgoff	1
	Miss E. Doherty	1
	Control and Distribution	5

END

Dtjic

7-86