

AD-R168 871

TESTING AND QUALIFICATION OF A TWELVE-CELL OXIDATION  
APPARATUS FOR CONDUCTING (U) DAVID W TAYLOR NAVAL SHIP  
RESEARCH AND DEVELOPMENT CENTER ANN. R J BOWEN ET AL.  
MAR 86 DTNSRDC/SME-86/01

1/1

UNCLASSIFIED

F/G 21/4

NL



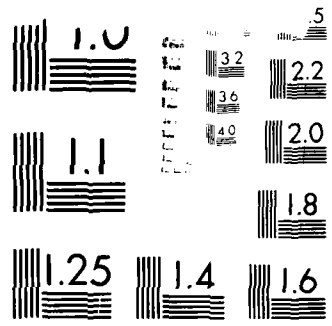

MICROCOPY RESOLUTION TEST CHART

12

ABCA/3/US/F-2/86

DTNSRDC/SME-86/01

TESTING AND QUALIFICATION OF A TWELVE-CELL OXIDATION APPARATUS  
FOR CONDUCTING ASTM D2274 STABILITY TESTS

# DAVID W. TAYLOR NAVAL SHIP RESEARCH AND DEVELOPMENT CENTER



Bethesda, Maryland 20084

**AD-A168 871**

**OTIC FILE COPY**

TESTING AND QUALIFICATION OF A TWELVE-CELL  
OXIDATION APPARATUS FOR CONDUCTING  
ASTM D2274 STABILITY TESTS

by

Robert J. Bowen and Edmund W. White

APPROVED FOR PUBLIC RELEASE;  
DISTRIBUTION UNLIMITED.

*Handwritten signature*

SHIP MATERIALS ENGINEERING DEPARTMENT  
RESEARCH AND DEVELOPMENT REPORT

March 1986

DTNSRDC/SME-86/01

# MAJOR DTNSRDC ORGANIZATIONAL COMPONENTS

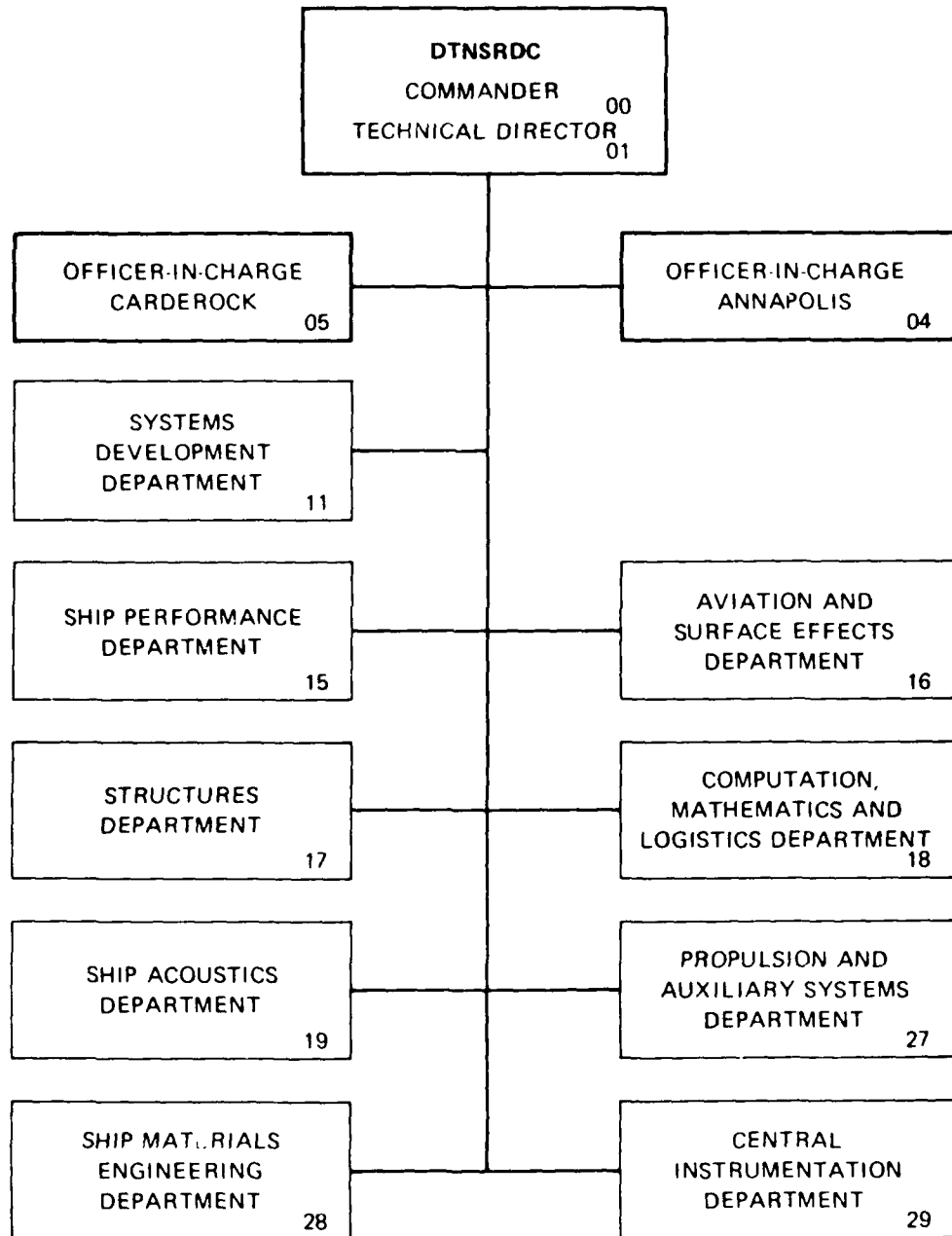

REPORT DOCUMENTATION PAGE

1a REPORT SECURITY CLASSIFICATION UNCLASSIFIED			1b RESTRICTIVE MARKINGS		
2a SECURITY CLASSIFICATION AUTHORITY			3 DISTRIBUTION / AVAILABILITY OF REPORT APPROVED FOR PUBLIC RELEASE; DISTRIBUTION UNLIMITED.		
2b DECLASSIFICATION / DOWNGRADING SCHEDULE			4 PERFORMING ORGANIZATION REPORT NUMBER(S) DTNSRDC/SME-86/01		
4 PERFORMING ORGANIZATION REPORT NUMBER(S) DTNSRDC/SME-86/01			5 MONITORING ORGANIZATION REPORT NUMBER(S)		
6a NAME OF PERFORMING ORGANIZATION David W. Taylor Naval Ship R&D Center		6b OFFICE SYMBOL (if applicable) DTNSRDC	7a NAME OF MONITORING ORGANIZATION David W. Taylor Naval Ship R&D Center (Code 2759)		
6c ADDRESS (City, State, and ZIP Code) Bethesda, MD 20084-5000			7b ADDRESS (City, State, and ZIP Code) Bethesda, MD 20084-5000		
8a NAME OF FUNDING / SPONSORING ORGANIZATION Office of the Chief of Naval Research		8b OFFICE SYMBOL (if applicable) ONCR 1263	9 PROCUREMENT INSTRUMENT IDENTIFICATION NUMBER Basic WR N0003785 WR 55005		
8c ADDRESS (City, State, and ZIP Code) Washington, DC 20362			10. SOURCE OF FUNDING NUMBERS		
		PROGRAM ELEMENT NO 63724N	PROJECT NO WR55005	TASK NO RD0838	WORK UNIT ACCESSION NO. DN578153
11 TITLE (Include Security Classification) Testing and Qualification of a Twelve-Cell Oxidation Apparatus for Conducting ASTM D2274 Stability Tests					
12 PERSONAL AUTHOR(S) Robert J. Bowen and Edmund W. White					
13a TYPE OF REPORT R&D		13b TIME COVERED FROM _____ TO _____		14. DATE OF REPORT (Year, Month, Day) March 1986	15 PAGE COUNT
16 SUPPLEMENTARY NOTATION					
17 COSATI CODES			18 SUBJECT TERMS (Continue on reverse if necessary and identify by block number)		
FIELD	GROUP	SUB-GROUP	Fuel Stability Apparatus Fuel		
			D2274 Apparatus Navy Fuel		
19 ABSTRACT (Continue on reverse if necessary and identify by block number)					
<p>A new twelve-cell oxidation apparatus for conducting fuel stability tests using ASTM D2274 Oxidation Stability of Distillate Fuel Oil (Accelerated Method) was subjected to an extensive qualification procedure. It was tested for physical integrity and temperature responsiveness and the twelve oxygen flowmeters and the temperature controls were calibrated. Finally, several batches of fuel were tested to compare operators, determine the standard deviation among replicates, and ascertain location effects. Insertion of 12 cells containing 350-ml fuel each at 18°C (65°F) resulted in a 6°C (11°F) drop in bath temperature with the original bath temperature recovered in approximately 20-25 minutes. The fuel in the tubes reached set point temperature within 1°C (2°F) in about 30 minutes.</p> <p style="text-align: right;">(Continued on reverse side)</p>					
20 DISTRIBUTION / AVAILABILITY OF ABSTRACT <input type="checkbox"/> UNCLASSIFIED/UNLIMITED <input checked="" type="checkbox"/> SAME AS RPT <input type="checkbox"/> DTIC USERS			21. ABSTRACT SECURITY CLASSIFICATION UNCLASSIFIED		
22a NAME OF RESPONSIBLE INDIVIDUAL Robert J. Bowen and Edmund W. White			22b TELEPHONE (Include Area Code) (301) 267-2860	22c OFFICE SYMBOL DTNSRDC/SME-86/01	



TABLE OF CONTENTS

	Page
LIST OF FIGURES. . . . .	iii
LIST OF TABLES . . . . .	iv
LIST OF ABBREVIATIONS . . . . .	v
ABSTRACT . . . . .	1
ADMINISTRATIVE INFORMATION . . . . .	1
INTRODUCTION AND BACKGROUND . . . . .	1
DESCRIPTION OF APPARATUS . . . . .	3
PROCEDURES FOR QUALIFICATION AND CALIBRATION . . . . .	3
TESTING FOR PHYSICAL INTEGRITY AND OPERABILITY . . . . .	3
TESTING FOR TEMPERATURE RESPONSIVENESS . . . . .	5
CALIBRATION OF INSTRUMENTS . . . . .	5
CONDUCTING TRIAL RUNS . . . . .	7
DISCUSSION OF RESULTS . . . . .	9
PHYSICAL INTEGRITY AND OPERABILITY . . . . .	9
TEMPERATURE RESPONSIVENESS . . . . .	9
CALIBRATION . . . . .	13
RESULTS OF TRIAL RUNS . . . . .	13
Comparison Between Operators . . . . .	13
Comparison Between Filter Systems . . . . .	14
Comparison Among Locations . . . . .	15
CONCLUSIONS . . . . .	16
ACKNOWLEDGMENTS . . . . .	17

LIST OF FIGURES

1 - Photograph of Twelve-Cell Oxidation Apparatus . . . . .	4
--	---

	Page
2 - Schematic Diagram Showing Connections to Each Cell . . . . .	6
3 - Schematic Diagram Showing Designation of Locations . . . . .	8
4 - Effect of Cell Insertion on Bath Temperature . . . . .	11
5 - Temperature Response of Fuel in Cell . . . . .	12

LIST OF TABLES

1 - Selected Properties of Arkansas Fuel . . . . .	7
2 - Comparison of Results from Two Operators . . . . .	13
3 - Two Methods of Determining Filterable Insolubles: Gooch Versus Membrane Filtration . . . . .	14
4 - Average Total Insolubles for Different Locations . . . . .	16

## LIST OF ABBREVIATIONS

API	American Petroleum Institute
ASTM	American Society for Testing and Materials
g	Gram
hp	Horsepower
hr	Hour
L/hr	liters per hour
$\mu$ m	Micrometer
mg	Milligram
ml	Milliliter
mm	Millimeter
o.d.	Outside diameter
vol	Volume
wt	Weight

## ABSTRACT

A new twelve-cell oxidation apparatus for conducting fuel stability tests using ASTM D2274 Oxidation Stability of Distillate Fuel Oil (Accelerated Method) was subjected to an extensive qualification procedure. It was tested for physical integrity and temperature responsiveness and the twelve oxygen flowmeters and the temperature controls were calibrated. Finally, several batches of fuel were tested to compare operators, determine the standard deviation among replicates, and ascertain location effects. Insertion of 12 cells containing 350-ml fuel each at 18°C (65°F) resulted in a 6°C (11°F) drop in bath temperature with the original bath temperature recovered in approximately 20-25 minutes. The fuel in the tubes reached set point temperature within 1°C (2°F) in about 30 minutes. The major conclusions were that the apparatus is acceptable for running D2274 accelerated stability tests and it provides a bath of uniform temperature with no location difference of statistical significance.

## ADMINISTRATIVE INFORMATION

The work described in this report was conducted during Fiscal Year 1985 as part of the Navy Energy Program - Fuels Chemistry. The work was performed under Program Element 63724N, Task Area Z0838 and was funded under the basic WR 0003785WR55005 by the Naval Material Command, Code 08E (Dr. Alan Roberts/Wayne Vreath). This program was block-funded to the David W. Taylor Naval Ship Research and Development Center with Dr. C. F. Krolick (Code 2750) as the Block Program Manager, with Mr. R. Strucko (Code 2759) as Program Engineer, and with Dr. E. W. White (Code 2832) as the Technical Manager for the Center. Mr. Robert J. Bowen was the primary laboratory chemist, although others participated.

## INTRODUCTION AND BACKGROUND

In early 1984, the volume of existing and anticipated work requiring testing in conformance with ASTM D2274 Oxidation Stability

of Distillate Fuel Oil (Accelerated Method)\* ASTM D943 Oxidation Characteristics of Inhibited Mineral Oils, which use the same basic oxidation apparatus, necessitated the acquisition of a new unit. The new apparatus, received in September 1984, was able to accommodate twelve oxidation cells in contrast to the eight cell capacity of the Center's other units.

Upon completion of the basic physical and electrical installation of the heating bath, laboratory personnel undertook the assembly of the glassware and accessory equipment, and subjected the assembled apparatus to qualification testing. Qualification testing, as used in this report, encompasses four activities, specifically:

1. Testing for physical integrity - primarily for absence of leaks from the liquid and oxygen systems; and for the operability of the fluid circulation systems and of the electric heating system.

2. Testing for temperature responsiveness, i.e., determining how quickly the electric heating system returns the bath temperature to its set point after cooling induced by the introduction of the twelve oxidation cells containing fuel at room temperature.

3. Calibrating the twelve oxygen flow meters and of the temperature measurement and control devices.

4. Conducting several runs to provide an overall check of the system operability, to compare operators, to determine the standard deviation or variance among replicates, and to ascertain whether there are cell location effects.

This report describes the apparatus and the procedures used in its qualification, presents the data obtained in the testing, and provides a discussion of results.

---

\*"1984 Annual Book of ASTM Standards," Vol. 05.02 Petroleum Products and Lubricants, American Society for Testing and Materials, Philadelphia, PA (1984).

## DESCRIPTION OF APPARATUS

In ASTM D2274, a 350 ml\* volume of filtered fuel is aged for 16 hr at 95°C (203°F) in a 45 mm o.d. (1-3/4 in.) x 600 ml (23-5/8 in.) oxidation cell while oxygen is bubbled through the fuel at 3 L/hr. After aging and cooling to room temperature, the total amount of insoluble (filterable insolubles plus adherent insolubles) is determined. The heating bath must be capable of controlling the temperature of the fuel in the oxidation cells within 0.2°C (0.4°F) and the oxygen flowmeters (one for each oxidation cell) must have an accuracy of  $\pm 0.3$  L/hr.

A photograph of the twelve cell oxidation unit is shown in Figure 1. Major specification details are also listed. A schematic diagram showing the arrangements of the oxygen and cooling water systems and the general assembly of each cell is shown in Figure 2.

To bring the heating bath to the desired temperature and to control that temperature within the  $\pm 0.2^\circ\text{C}$  ASTM D2274 limits, the manufacturer provided a 230 volt, 50/60 Hz, 16 ampere system containing a thermostatically-controlled, 750-watt heater; two 1500-watt heaters that can be turned on or off by a toggle switch, a 1/20 hp stirrer, and a thermistor probe with a solid state controller.

To control the oxygen flow to each oxidation cell, the manufacturer mounted highly accurate flowmeters on a common manifold and a sensitive needle valve to each cell. With this arrangement, an accuracy of  $3 \pm 0.01$  L/hr is claimed.

## PROCEDURES FOR QUALIFICATION AND CALIBRATION

### TESTING FOR PHYSICAL INTEGRITY AND OPERABILITY

The first step in qualifying the apparatus consisted of three checks of integrity and of mechanical operability:

1. The heating bath was filled with about 72 liters of low viscosity silicone oil and the operator checked for any leaks.

---

\*A complete list of abbreviations is given on page v.

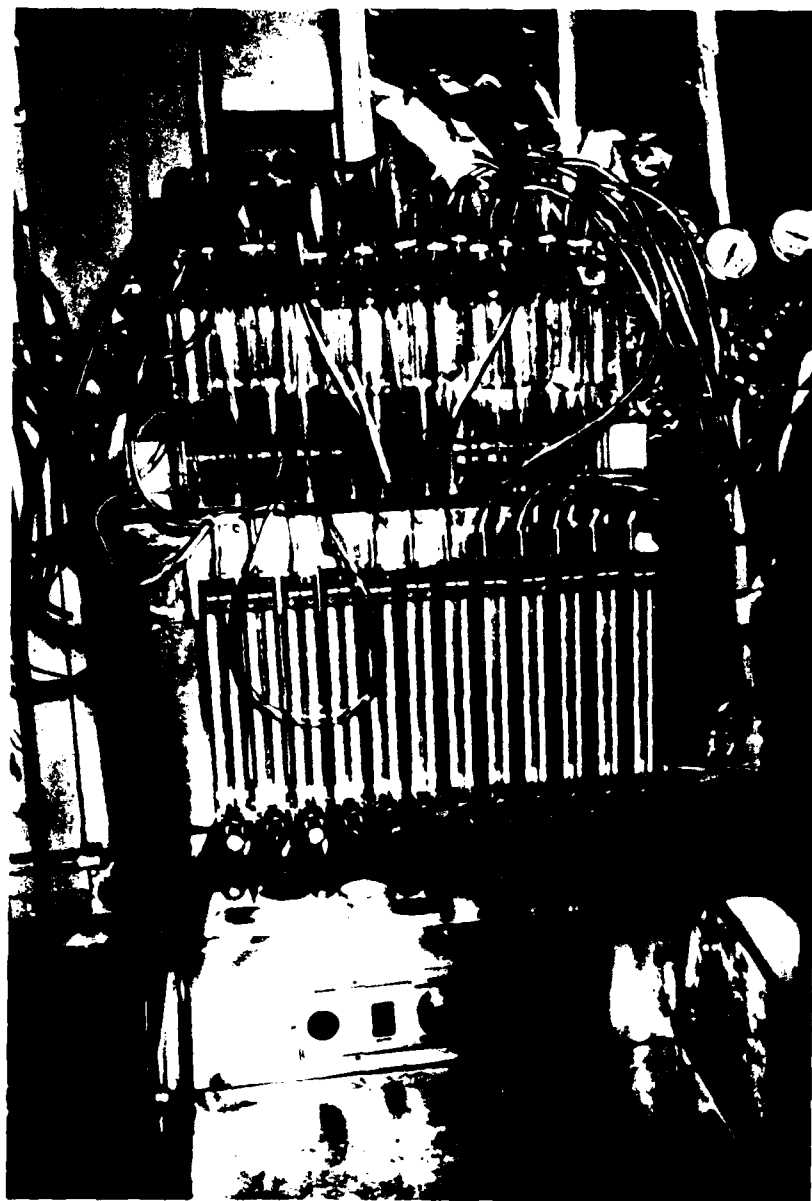

Supplier: Koehler Instrument Company, Inc.  
Bohemia, New York

Model: K122-12A      Serial: 320      NIN: 167-737538

Dimensions:      57 x 48 x 81 cm (22-1/2 x 19 x 32 in)  
Tank Capacity:      71.9 liters (19 gal), approximately  
Net Weight:      58.9 kg (130 lb), including glassware

Figure 1 - Photograph of Twelve-Cell Oxidation Apparatus

2. The electrical system was turned on and the operator checked that the stirrer and the electric heaters in the heating bath were operating.

3. Valves in the oxygen supply system were opened and the various connections in the system were checked for leaks with soap solution.

#### TESTING FOR TEMPERATURE RESPONSIVENESS

Tests were conducted to determine how quickly all three heaters, would bring the bath oil up to the 95°C (203°F) operating temperature. Once the bath had reached temperature, a type-T copper-constantan thermocouple probe with a Doric Minitrend 205 digital read-out was used to ascertain uniformity of bath temperature by testing the four corners of the bath and comparing those values with the mid-bath temperature.

To test the effect of placing samples in the bath, twelve oxidation cells, each containing 350 ml of fuel at about 18°C (65°F), were placed in the bath. Then bath temperatures were measured at 2 to 5 min intervals to establish the temperature recovery response curve. Simultaneously, the temperature of the fuel in one of the mid-bath cells, through which oxygen was flowing at a rate of 3 L/hr, was measured to determine how fast it approached the 95°C operating temperature.

#### CALIBRATION OF INSTRUMENTS

The oxygen flow meters furnished by the supplier were Brooks type R-2-15-AAA rotameters with a 0 - 150 scale. A calibration curve provided with the rotameters showed they were capable of measuring oxygen flows of 0 - 4.2 L/hr under standard conditions of one atmosphere of pressure and 70°F (about 21°C).

The oxygen rotameter calibration curves showed that they should deliver 3.0 L/hr at a scale setting of 120, which is the volume flow rate specified in the ASTM D2274 procedure. This was checked on all twelve rotameters using a Hewlett-Packard soap-film flow meter as a secondary standard.

Figure 2a - Oxygen Flow System for Each Cell

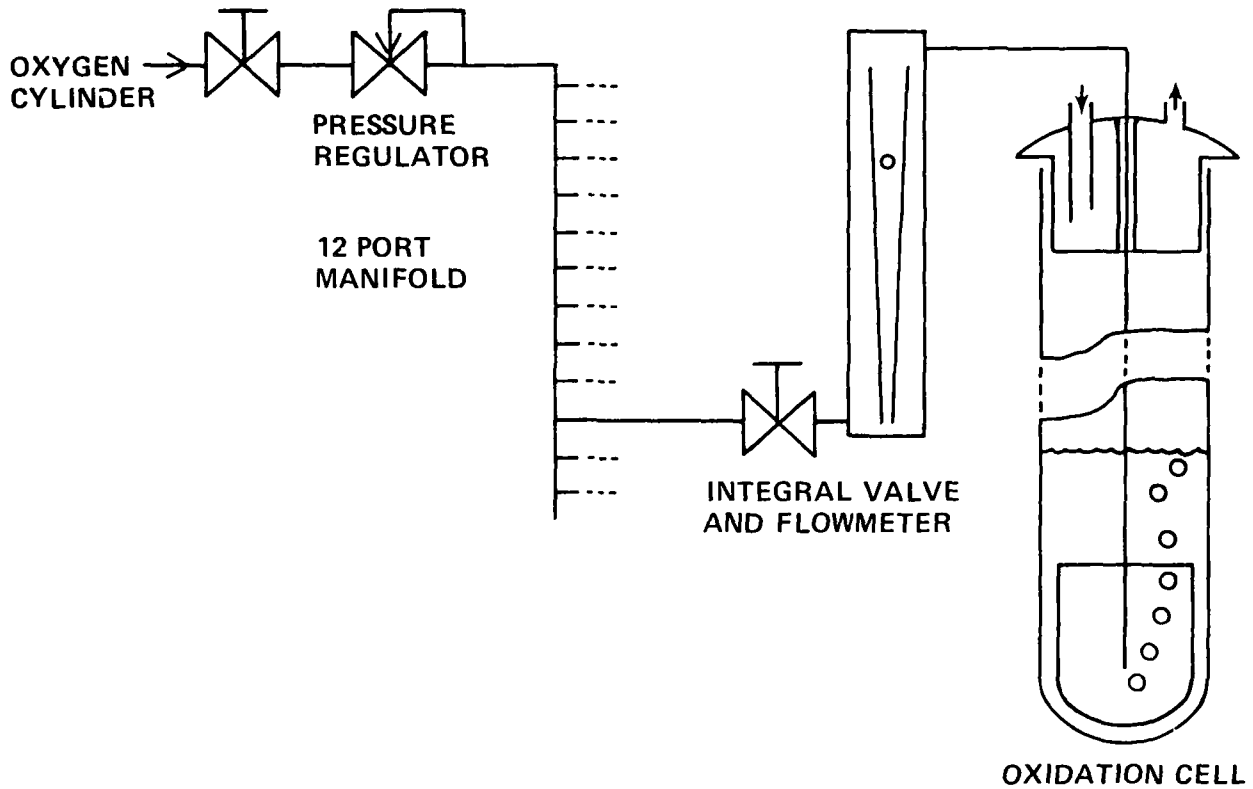

Figure 2b - Cell Arrangement and Coolant Flow Path in Twelve Cell Bath

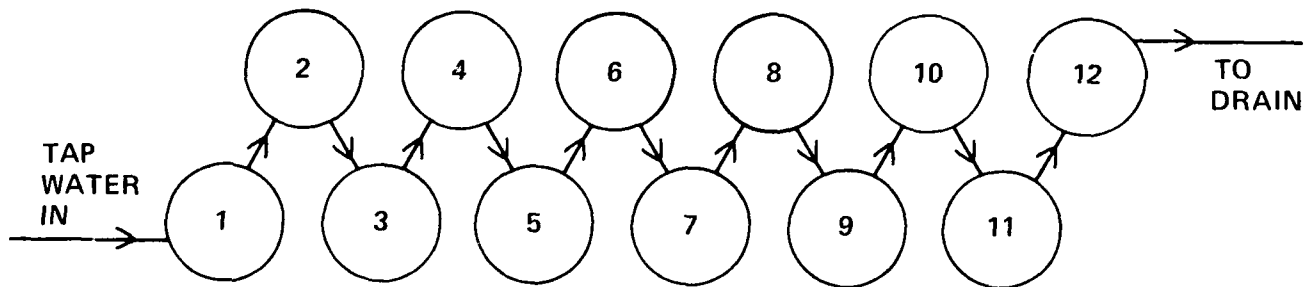

Figure 2 - Schematic Diagram Showing Connections to Each Cell

The temperature setting on the thermostatically-controlled, 750-watt heater is a ten-turn potentiometer. Tests were run to determine the setting of this device. Bath temperatures were originally determined by placing a partial-immersion, 0 - 110°C, mercury glass thermometer through the port provided for this purpose by the manufacturer. Later, the copper-constantan thermocouple with the Doric digital read-out was substituted. The Doric instrument had been calibrated by the Center's Central Instrumentation Department.

#### CONDUCTING TRIAL RUNS

Several trial runs were made to test the apparatus over the normal operating period (16 hr), to compare operators and procedures, and to ascertain whether cell location in the bath made any difference. The fuel used was a military diesel fuel that had been acquired some months earlier after prior extended storage at a facility in Arkansas. Some fuel properties are shown in Table 1.

TABLE 1 - SELECTED PROPERTIES OF ARKANSAS FUEL

Physical Properties	
Gravity, degree, API at 15.6°C	35.0
ASTM Color	2.0
Viscosity, cSt at 40°C	2.3
Pour Point, °C	-31
Cloud Point, °C	-21
Demulsibility Time, min.	2
Flash Point, °C	77
Distillation	
50% point, °C	256
90% point, °C	302
End Point, °C	330
Chemical Properties	
Sulfur Content (Wt %)	0.40
Carbon Residue on 10% bottoms, (Wt %)	0.05
Water and Sediment, (% Vol)	0.002
Ash Content (Wt %)	0.003
Acid Number, mg KOH/g	0.02
Accelerated Stability, mg/100 ml	3.2

Two operators each ran twelve-cell replicates. One operator, an experienced laboratory chemist, used membrane filters in each filtration step. The second, a chemistry student from a local university, used membrane filters in working up six of the cells and the current ASTM D2274 glass-fiber filter paper technique in working up the other six cells.

The various trial results were compared statistically. Standard deviations were obtained for each operator's results, for each of the two types of filtration, and for each of three locations (see Figure 3). These were then used to test the null hypothesis by the Student-t technique to determine if the differences were significant.

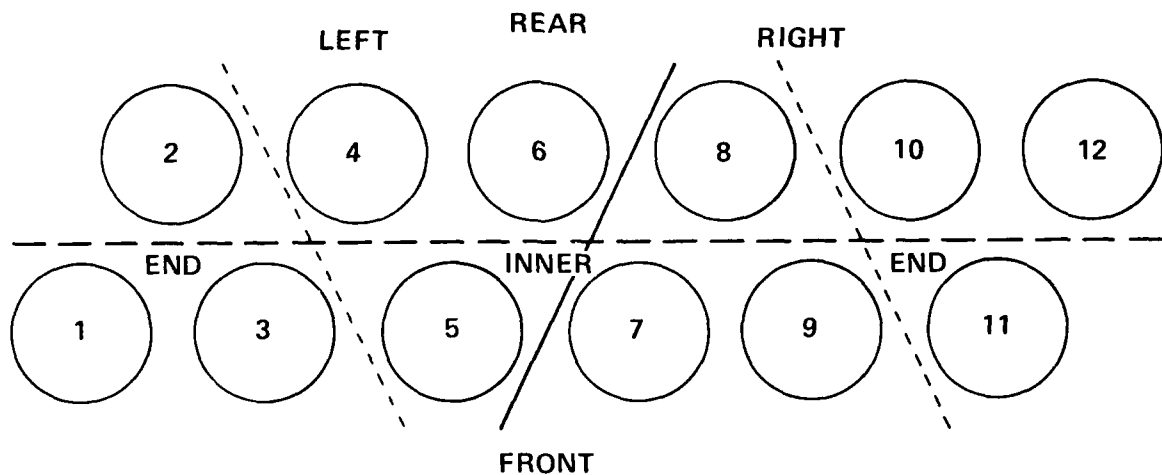

Figure 3 - Schematic Diagram Showing Designation of Locations

## DISCUSSION OF RESULTS

### PHYSICAL INTEGRITY AND OPERABILITY

After the heating bath had been filled with silicone heat transfer oil, a visual examination showed the apparatus to be free of leaks. The electrical system was found to be operable, i.e., all three of the electrical heaters were functional and the circulating system stirrer was operating. A test of the oxygen system connections using soap solution showed them to be free of leaks. In short, the apparatus passed the tests for physical integrity and operability.

### TEMPERATURE RESPONSIVENESS

The heating bath can be brought from a room temperature of about 18°C (65°F) to an operating temperature of 95°C in about an hour when all three heating elements are used. With only the two 1500 watt units in use, it takes about 2 hr; and with only the 750 watt, thermostatically-controlled heater in operation, it takes between 3 and 4 hr. When time permits, the operators prefer to use only the 750 watt heater, because the other heaters are not thermostatically-controlled. Hence, the bath temperature can overshoot the desired set point when the auxiliary heating elements are employed if not monitored closely.

After the bath had reached 95°C (203°F) as measured by a partial-immersion, glass thermometer, the uniformity of temperature was checked using a thermocouple probe. The probe recorded temperatures of slightly over 93°C (200°F) both at the middle of the bath and at each of the four corners. This showed a good uniformity of temperature throughout the bath, and also revealed a discrepancy between the temperatures measured by the glass thermometer and those indicated by the thermocouple probe.

The results given by the thermocouple probe were deemed the more reliable for several reasons. First, the Doric instrument had been calibrated and thermocouples in general are quite accurate.

Second, the glass thermometer was a partial immersion type in which the exposed stem is supposed to be exposed to room temperature surroundings. In the current use, the stem was exposed to high temperatures above the heating oil surface and would thus be expected to read higher than it should. The thermocouple system has been adopted for all subsequent use of the apparatus.

Figure 4 shows the effect on the bath oil temperature of inserting twelve oxidation cells (each containing 350 ml of fuel at about 18°C (65°F)). The temperature measured by the thermocouple probe dropped rapidly from slightly over 93°C (200°F) to a low of about 87°C (189°F) after seven minutes. Then, the 750 watt heater began to raise the bath oil temperature to the set point at an average rate of 0.3°C (0.5°F) per min. After 20 min from the insertion of the cells, the bath temperature had regained about two-thirds of the lost temperature and had reached slightly over 91°C (196°F). Measurements were stopped at this point, but extrapolation of the temperature curve indicates full recovery would have been attained in about 1/2 hr.

Figure 5 shows the temperature variation of the fuel in one of the oxidation cells near the center of the cluster. The fuel temperature, which started at about 18°C (65°F), rose rapidly. By the time the bath oil had dropped to its lowest temperature, i.e., after seven minutes, the temperature of the fuel in the oxidation cell had climbed to about 77°C (170°F). Within 30 min, the fuel temperature had reached slightly above 92°C (198°F), i.e., within about 1°C (2°F) of the bath temperature. A similar temperature level after 42 min indicated that this is the equilibrium temperature. The 1/2 hr required for the fuel to reach the test temperature is a small fraction of the full 16-hr test period and will not produce any major effect on the results.

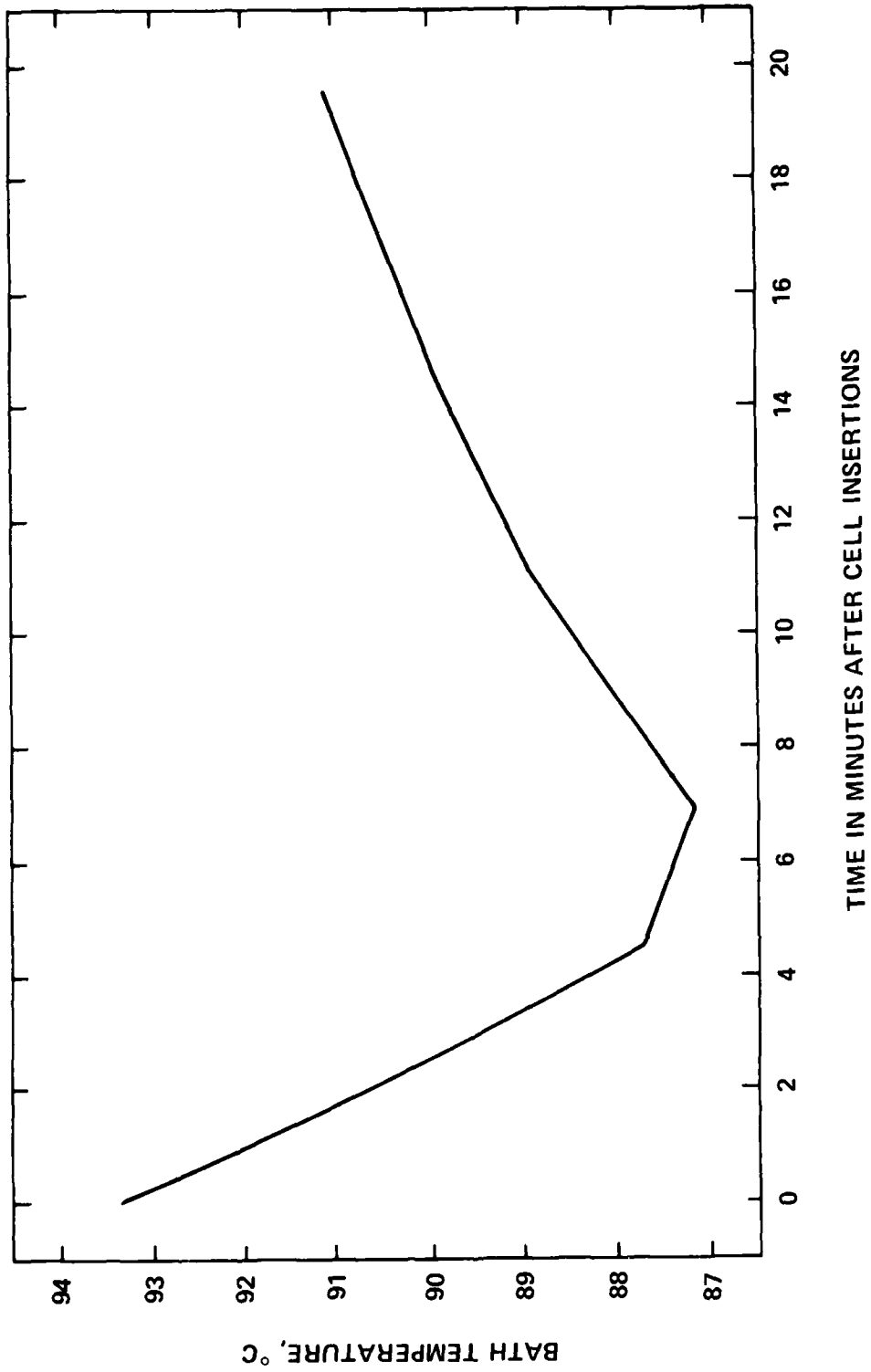

Figure 4 - Effect of cell insertion on bath temperature

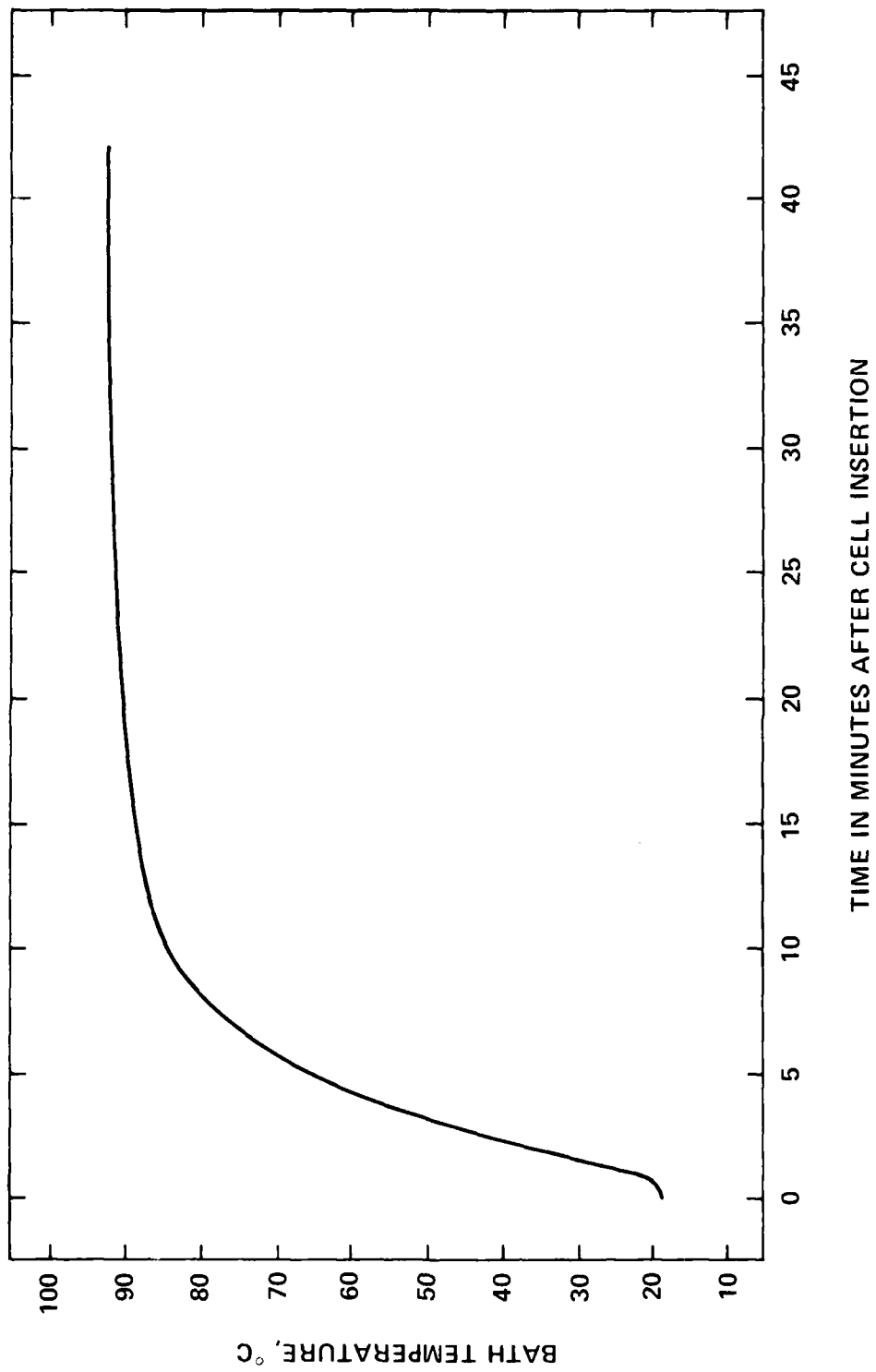

Figure 5 - Temperature response of fuel in cell

ASTM D2274 is slightly ambiguous regarding the temperature of the fuel in the oxidation cell. It mentions both aging at 95°C and aging in a bath at 95°C. The slight discrepancy between the bath temperature and the fuel temperature noted in the previous paragraph indicates that different interpretations of D2274 could lead to slightly different fuel aging temperatures at two different laboratories. A clarification of intent should be provided in the next draft of ASTM D2274.

#### CALIBRATION

Flow rates at a scale setting of 120 on the Brooks rotameters were found by use of the soap film flow meter to be  $3.0 \pm 0.1$  l/hr.

#### RESULTS OF TRIAL RUNS

##### Comparison Between Operators

The overall results obtained by the two operators are summarized in Table 2. The data of the first operator are based on twelve data points in each case. The second operator experienced some breakage, so the data for the filterable insolubles are based on only ten data points. The data for the adherent insolubles and for the total insolubles are based on only nine data points.

TABLE 2 - COMPARISON OF RESULTS FROM TWO OPERATORS

Item	Range	Mean	Standard
		mg/100 ml	
First Operator			
Adherent Insolubles	0.63 - 1.32	0.99	0.20
Filterable Insolubles	2.75 - 3.07	2.85	0.09
Total Insolubles	3.48 - 4.09	3.84	0.19
Second Operator			
Adherent Insolubles	0.73 - 1.33	1.00	0.19
Filterable Insolubles	2.67 - 3.80	3.22	0.31
Total Insolubles	3.58 - 4.89	4.19	0.38

Several interesting points are noted. First, both operators obtained essentially the same values for the average adherent insolubles, (0.99 mg/100 ml for the first operator and 1.00 mg/100 ml for the second) and the standard deviation associated with these values (0.20 and 0.19, respectively) were almost identical.

Second, the average levels of filterable insolubles differed greatly (2.85 mg/100 ml for the first operator versus 3.22 mg/100 ml for the second operator). Naturally, this led to a major difference in the average total insolubles obtained by the two operators (3.84 mg/100 ml for the first operator versus 4.19 mg/100 ml for the second). A Student-t test of the null hypothesis indicates that the two results are significantly different (98% confidence level), even though the difference between the means is only about 9%.

#### Comparison Between Filter Systems

The second operator obtained five data points with the Gooch filter system specified in the existing D2274 and four data points with a Millipore membrane filter. Table 3 summarizes the results obtained by the two procedures.

TABLE 3 - TWO METHODS OF DETERMINING FILTERABLE INSOLUBLES  
GOOCH VERSUS MEMBRANE FILTRATION

Item	Range	Average	Standard
		mg/100 ml	
Standard Deviation			
Gooch Glass-Fiber Paper			
Adherent Insolubles	0.73 - 1.14	0.96	0.19
Filterable Insolubles	3.17 - 3.80	3.31	0.28
Total Insolubles	3.94 - 4.89	4.24	0.39
Membrane Filter			
Adherent Insolubles	0.89 - 1.33	1.05	0.20
Filterable Insolubles	2.67 - 3.51	3.09	0.35
Total Insolubles	3.58 - 4.49	4.13	0.41

Adherent gum determinations, which are not affected by the filter system used, are approximately the same--0.96 mg/100 ml in the conventional D2274 procedure and 1.05 mg/100 ml in the membrane procedure--with standard deviations of 0.19 and 0.20 mg/100 ml, respectively.

As expected, differences of larger magnitude do appear in the values of the filterable insolubles. Surprisingly, the membrane filter with a nominal 1.2  $\mu\text{m}$  pore size captured a smaller average quantity (3.09 mg/100 ml) of filterable material than the 3.31 mg/100 ml captured by the coarser 1.6  $\mu\text{m}$  glass-fiber filter paper specified in the D2274 procedure. However, the glass-fiber filter medium is used in a double layer so the effective porosity was probably less than 1.6  $\mu\text{m}$ . Moreover, the difference between the two means is not statistically significant.

The resultant total insolubles obtained by the two procedures are, on average, quite similar--4.24 mg/100 ml by the conventional procedure and 4.13 mg/100 ml by the membrane filtration procedure, with standard deviations of 0.39 and 0.41 mg/100 ml, respectively. The Student-t test indicates that these differences are not statistically significant at the 95% confidence level.

#### Comparisons Among Locations

The sets of twelve data points obtained by the first operator have been used to evaluate possible differences that might result from the chance location of an oxidation cell in different parts of the heating bath. The three major points of comparison were those of the front bank of cells versus the rear bank; the cells left of the mid-point versus those right of the mid-point; and the end cells versus those in the interior (See Figure 3). The average level of total insolubles for each of these groups of oxidation cells is shown in Table 4.

TABLE 4 - AVERAGE TOTAL INSOLUBLES FOR DIFFERENT LOCATIONS

Location	Range	Average	Standard Deviation
	mg/100 ml		
Front bank	3.75 - 4.09	3.91	0.15
Rear bank	3.48 - 4.06	3.77	0.21
Right side	3.48 - 4.09	3.85	0.23
Left side	3.58 - 4.06	3.83	0.16
End group	3.48 - 3.88	3.79	0.15
Inner group	3.58 - 4.09	3.89	0.22

Table 4 indicates that the averages of the total insolubles for each pair of locations are very close. The front-rear comparison shows 3.91 mg/100 ml for the front bank versus 3.77 mg/100 ml for the rear bank of cells. The right-left comparison yields 3.85 mg/100 ml for the right half versus 3.83 mg/100 ml for the left half. The six end cells yielded total insolubles averaging 3.79 mg/100 ml versus 3.89 mg/100 ml for the six interior cells. The Student-t evaluations show that none of these differences is significant at the 95% confidence level.

#### CONCLUSIONS

The major conclusions that can be reached from the information contained in this report are that:

1. The apparatus is acceptable for running ASTM D2274 stability tests as judged by its physical integrity, mechanical operability, ability to control oxygen flow rates, and responsiveness to temperature change caused by insertion of oxidation cells.

2. The apparatus provides a bath of uniform temperature with no location difference of statistical significance.

3. The use of Millipore membrane vs glass fiber filters for the filtration required in ASTM D2274 yields total insoluble levels that are not statistically different.

4. Differences in the results obtained by two operators are probably significant at the 98% confidence level. This supports information obtained in previous work that the operator technique may be the major factor in differences in reproducibility between labs.

#### ACKNOWLEDGEMENTS

The authors wish to thank Miss Donna Smith, DTNSRDC (Code 2832) for her assistance in obtaining data included in this report.

INITIAL DISTRIBUTION

Copies		CENTER DISTRIBUTION		
		Copies	Code	Name
2	OCNR (Code 1263) Dr. A. Roberts W. Vreatt	1	275	Dr. C.F. Krolick
1	NAVSEA (Code 05M4)	3	2759	R. Strucko
2	NAVPETOFF L. Long	1	2804	Dr. G. Bosmajian
		1	2809	A. A. Malec
1	NAVSESSES PHILA (Code 053)	3	283	H. H. Singerman
1	NAPC C. J. Nowack (Code PE 33)	1	2832	J. Dray
		10	2832	Dr. E.W. White
3	NRL (Code 6180) Dr. R. Hazlett Dr. D. Hardy Dr. R. Morris	1	2832	R. J. Bowen
		1	2832	M. Klinkhammer
1	DFSC C. Martin (Code T)	1	522.1	TIC
		2	5231	Office Services
12	DTIC			
2	NIPER D. W. Brinkman K. O. Sterling			
1	SWRI L. Stavinoha S. Westbrook G. Lee			
1	U.S.A. BRADC M. LePera (Code STRBE-VF)			
25	IEP/ABCA/3/UK			
15	IEP/ABCA/3/Canada			
10	IEP/ABCA/3/Australia			

DTNSRDC ISSUES THREE TYPES OF REPORTS

1. DTNSRDC REPORTS, A FORMAL SERIES, CONTAIN INFORMATION OF PERMANENT TECHNICAL VALUE. THEY CARRY A CONSECUTIVE NUMERICAL IDENTIFICATION REGARDLESS OF THEIR CLASSIFICATION OR THE ORIGINATING DEPARTMENT.

2. DEPARTMENTAL REPORTS, A SEMIFORMAL SERIES, CONTAIN INFORMATION OF A PRELIMINARY, TEMPORARY, OR PROPRIETARY NATURE OR OF LIMITED INTEREST OR SIGNIFICANCE. THEY CARRY A DEPARTMENTAL ALPHANUMERICAL IDENTIFICATION.

3. TECHNICAL MEMORANDA, AN INFORMAL SERIES, CONTAIN TECHNICAL DOCUMENTATION OF LIMITED USE AND INTEREST. THEY ARE PRIMARILY WORKING PAPERS INTENDED FOR INTERNAL USE. THEY CARRY AN IDENTIFYING NUMBER WHICH INDICATES THEIR TYPE AND THE NUMERICAL CODE OF THE ORIGINATING DEPARTMENT. ANY DISTRIBUTION OUTSIDE DTNSRDC MUST BE APPROVED BY THE HEAD OF THE ORIGINATING DEPARTMENT ON A CASE BY CASE BASIS.

END

Dtjic

7-86