

MICROCOPY

21183

2

Quarterly Technical Summary

AD-A169 063

Weather Radar Studies

30 September 1985

Lincoln Laboratory

MASSACHUSETTS INSTITUTE OF TECHNOLOGY

LEXINGTON, MASSACHUSETTS

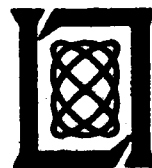

Prepared for the Federal Aviation Administration.

Document is available to the public through
the National Technical Information Service,
Springfield, VA 22161.

DTIC
ELECTE
JUN 30 1986

A

D

86 6 27 047

NTIC FILE COPY

This document is disseminated under the sponsorship of the Department of Transportation in the interest of information exchange. The United States Government assumes no liability for its contents or use thereof.

1. Report No. DOT/FAA-PM-86-06	2. Government Accession No. <i>A169062</i>	3. Recipient's Catalog No.	
4. Title and Subtitle Weather Radar Studies		5. Report Date 30 September 1985	6. Performing Organization Code
7. Author(s) David M. Bernella		8. Performing Organization Report No.	
9. Performing Organization Name and Address Massachusetts Institute of Technology Lincoln Laboratory P.O. Box 73 Lexington, MA 02173-0073		10. Work Unit No. (TRAIS)	11. Contract or Grant No. DT-FA01-80-Y-10546
12. Sponsoring Agency Name and Address Department of Transportation Federal Aviation Administration Systems Research and Development Service Washington, DC 20591		13. Type of Report and Period Covered Quarterly Technical Summary 1 July — 30 September 1985	
15. Supplementary Notes The work reported in this document was performed at Lincoln Laboratory, a center for research operated by Massachusetts Institute of Technology, under Air Force Contract F19628-85-C-0002.		14. Sponsoring Agency Code	
16. Abstract <p>FAA-funded Doppler weather radar activities during the period 1 July to 30 September 1985 are reported.</p> <p>The test-bed Doppler weather radar system making measurements in Olive Branch, Mississippi, was fully operational. Additionally, the University of North Dakota C-band Doppler weather radar completed its 1985 measurements. Weather measurements were conducted on a number of frontal showers and thunderstorms and on numerous scattered airmass thunderstorms. Some 68 microbursts were observed during the radar operation with the bulk of the microbursts occurring in July to mid September. Thirty-six gust fronts were observed as well.</p> <p>The University of North Dakota Citation aircraft made airborne turbulence microburst and gust front measurements on nine days in the period 30 July to 19 August. The aircraft lost 500 ft of altitude and encountered downdrafts of 50 knots in penetrating the downdraft region of one microburst.</p> <p>The Lincoln mesonet was fully operational throughout the period. The 1984 peak wind speed data from the mesonet and the Memphis International Airport LLWSAS data have been analyzed to determine ground level wind-shear characteristics in the Memphis area.</p> <p>Doppler weather radar data from the National Center for Atmospheric Research JAWS program and the National Severe Storms Laboratory are being analyzed to develop low-altitude wind-shear detection algorithms. Analysis of the data collected in the 1983 Boston area coordinated aircraft-Doppler weather radar turbulence experiment was largely completed. The 1983 data showed a high false alarm rate for the current NEXRAD/CWP turbulence product for the 1983 Boston area storms.</p> <p>Work continued on the development of weather radar products for the Central Weather Processor with particular emphasis on the correlation tracking and extrapolated weather map algorithms and an algorithm to generate the vertical cross sections along a user specified axis.</p>			
17. Key Words <p>weather radar aviation weather products low-altitude wind shear turbulence NEXRAD Doppler radar Central Weather Processor</p>		18. Distribution Statement <p>Document is available to the public through the National Technical Information Service, Springfield, VA 22161.</p>	
19. Security Classif. (of this report) Unclassified	20. Security Classif. (of this page) Unclassified	21. No. of Pages 60	22. Price

ABSTRACT

FAA-funded Doppler weather radar activities during the period 1 July to 30 September 1985 are reported.

The test-bed Doppler weather radar system making measurements in Olive Branch, Mississippi, was fully operational. Additionally, the University of North Dakota C-Band Doppler weather radar completed its 1985 measurements. Weather measurements were conducted on a number of frontal showers and thunderstorms and on numerous scattered air mass thunderstorms. Some 68 microbursts were observed during the radar operation with the bulk of the microbursts occurring in July to mid September. Thirty-six gust fronts were observed as well.

The University of North Dakota Citation aircraft made airborne turbulence microburst and gust front measurements on nine days in the period 30 July to 19 August. The aircraft lost 500 ft of altitude and encountered downdrafts of 50 knots in penetrating the downdraft region of one microburst.

The Lincoln mesonet was fully operational throughout the period. The 1984 peak wind speed data from the mesonet and the Memphis International Airport LLWSAS data have been analyzed to determine ground level wind-shear characteristics in the Memphis area.

Doppler weather radar data from the National Center for Atmospheric Research JAWS program and the National Severe Storms Laboratory are being analyzed to develop low-altitude wind-shear detection algorithms. Analysis of the data collected in the 1983 Boston area coordinated aircraft-Doppler weather radar turbulence experiment was largely completed. The 1983 data showed a high false alarm rate for the current NEXRAD/CWP turbulence product for the 1983 Boston area storms.

Work continued on the development of weather radar products for the Central Weather Processor with particular emphasis on the correlation tracking and extrapolated weather map algorithms and an algorithm to generate the vertical cross sections along a user specified axis.

TY
3

Accession For	
NTIS GRA&I	<input checked="" type="checkbox"/>
DTIC TAB	<input type="checkbox"/>
Unannounced	<input type="checkbox"/>
Justification	
By _____	
Distribution _____	
Availability Codes	
Av. _____	_____
Dist _____	Spec _____
A1	

TABLE OF CONTENTS

Abstract	iii
List of Illustrations	vii
List of Tables	vii
I. INTRODUCTION	1
II. TEST-BED DEVELOPMENT	3
A. Radome	4
B. Antenna	4
C. Antenna Pedestal	4
D. Transmitter/ Receiver	5
E. Signal Processor	5
1. Overview	5
2. Signal Processor Status	7
F. Data Acquisition and Analysis (DAA) Processor	8
1. Overview	8
2. DAA Hardware Status	9
3. DAA Software Status	10
a. Lags to Factors	11
b. Factors to Moments	12
c. Clutter Map	12
d. Resampling	12
e. Control Processing	13
G. Radar/Antenna Controller	13
H. Main Minicomputer	15
I. Test-Bed Enhancements	18
1. Apollo Displays	20
2. Increase PRF and Scan Rates	20
3. Streamline Diagnostic and Calibration Routines	21
III. SITE PLANNING AND OPERATION	23
A. Memphis Sites	23
1. Lincoln Radar Site	23
2. University of North Dakota (UND) Site	23
3. Mesonet Sites	23
B. Huntsville Site Planning	23
C. Memphis Operations	25
1. Lincoln Radar Measurements	25
2. Mesonet Operations	25
3. Low-Level Wind-Shear Alert System (LLWSAS)	
Data Recording	26

4. UND Radar Site Operations	26
5. Aircraft Support	27
6. Additional Weather Data	27
IV. EXPERIMENTAL DATA REDUCTION AND ALGORITHM DEVELOPMENT	29
A. Perkin-Elmer (P.E) Computer Systems	29
B. Radar Data Analysis Software Development	29
1. Translators	30
2. Utilities	30
3. Graphics	30
4. Software Maintenance	31
C. Mesonet/LLWSAS Data Analysis	31
D. Low-Altitude Wind-Shear (LAWS) Detection Algorithm Development	32
E. Turbulence Detection Algorithm Assessment	36
F. Clutter Environment Assessment	37
V. USE OF WEATHER RADAR DATA WITHIN THE CENTRAL WEATHER PROCESSOR (CWP)	41
A. Federal Meteorological Handbook Support	41
B. CWP Program Office Support	41
VI. SPECIFICATION OF NEXRAD PRODUCTS FOR USE IN THE CENTRAL WEATHER PROCESSOR	43
References	47
Principal Contributors	47
Glossary	49

LIST OF ILLUSTRATIONS

Figure No.		Page
II-1	FL-2 Test-Bed Block Diagram	4
II-2	Block Diagram of Instantaneous AGC for the FL-2 Test-Bed	6
II-3	Signal Processor Architecture	7
II-4	DAA Processor Block Diagram	8
II-5	DAA Data Flow for Basic Data Processing	11
II-6	Real-Time Control Computer and Its Interfaces	16
II-7	Real-Time Program Data Flow	19
III-1	Huntsville, Alabama, Area Site Map	24
IV-1	General Microburst Detection Algorithm	32
IV-2	Status of Feature Calculation Techniques	33
IV-3	Divergent Outflow Algorithm	34
IV-4	Winds/dBz 1841Z 26 June 1985 — Hickory Ridge Microburst	35
IV-5	Average Number of Gates per Cartesian Square	38
IV-6	SCR vs Range After CMAP Filter for 0 dBz Signal, Radar-Cross-Section Density, and Representative Weibull Slopes	40

LIST OF TABLES

Table No.		Page
II-1	DAA Processing Element (PE) Status (as of 30 September 1985)	9
II-2	Timing Considerations	12

WEATHER RADAR STUDIES

I. INTRODUCTION

The principal areas of emphasis for the weather radar program over the period July through September 1985 have been:

- (a) Continued development of a transportable Doppler weather radar test-bed to be utilized in a series of experimental programs during 1985-87.
- (b) Reduction of data from the coordinated Doppler weather radar-aircraft experiments in the Boston, Massachusetts, area during the summer of 1983.
- (c) Continuation of the first set of transportable test-bed experiments in the Memphis, Tennessee, area.
- (d) Analyses in support of terminal weather surveillance by Doppler weather radar.
- (e) Development of detailed specifications for certain Central Weather Processor (CWP) products to be generated by the Next Generation Weather Radar (NEXRAD) system.

Progress in each of the above areas is described in the sections which follow.

II. TEST-BED DEVELOPMENT

The FAA-Lincoln Laboratory transportable test-bed (FL-2) is a NEXRAD-like Doppler radar that can be used for the following functions:

- (1) Resolving the principal uncertainties in algorithms for detection and display of en route and terminal hazardous weather regions.
- (2) Obtaining feedback from operationally oriented users on the utility of strawman end products for improving safety and efficiency of airspace utilization.
- (3) Investigating Doppler weather radar-CWP interface issues.
- (4) Providing a data base for FAA specification of NEXRAD, terminal weather radar and NEXRAD/CWP interfaces.

During the 1985 experiments, the transportable test-bed radar, is being used in the following modes:

- (1) As a terminal Doppler weather radar to detect low-altitude wind shear (LAWS) and other hazards in an 'Off-airport' mode using sector planned position indicator (PPI) scans with occasional range height indicator (RHI) scans to focus on microburst/downburst detection in midair stage as well as outflow detection.
- (2) As a NEXRAD 'network' sensor with a 5-min volume scan and principal focus on products of particular interest to the FAA such as turbulence, layered reflectivity, and LAWS.
- (3) For 'scientific' data acquisition [as in the Joint Airport Weather Studies (JAWS) Project and National Severe Storms Laboratory (NSSL) Spring Programs] characterized by scientist-controlled scan patterns based on real-time three-moment displays.

Figure II-1 shows a block diagram of the test-bed.

The test-bed activity during this quarter focused on correcting some problems that surfaced during the early data taking exercises, adding some refinements to the system and gathering as much significant Doppler weather data as possible.

A. RADOME

The antenna radome is an inflatable 55-foot diameter Dacron bag, manufactured by Birdair Corporation, Buffalo, New York. The radome is kept inflated by a dual blower pressure system that is controlled by an external anemometer. The radome commenced use at the Olive Branch, Mississippi, field site in August 1984. An unplanned deflation occurred in August 1984 as a result of lightning damage to the blower power system. Since that time, the radome has operated satisfactorily.

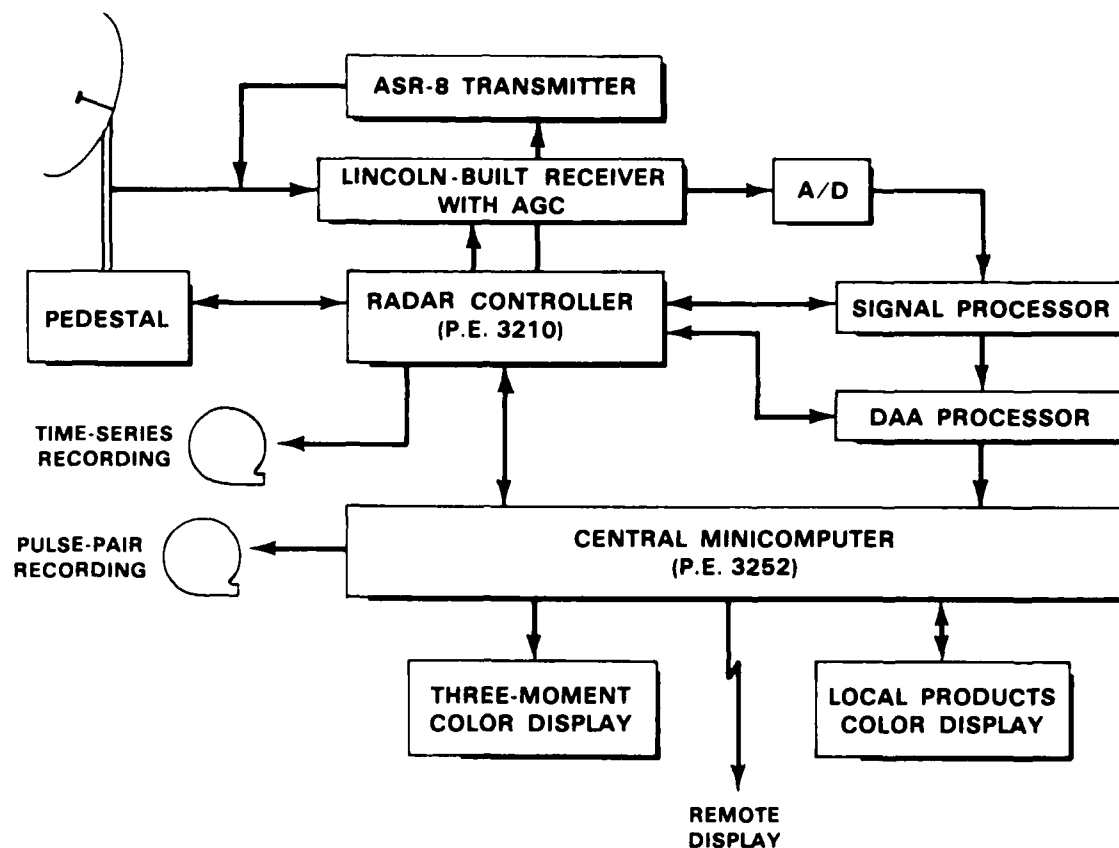

136143-N-02

Figure II-1. FL-2 test-bed block diagram.

B. ANTENNA

The 33-foot diameter parabolic reflector antenna has a primary illumination from the feed horn designed to yield a 1° beamwidth with first sidelobes < -25 dB. The dish was fabricated and tested by Hayes and Walsh, Cohasset, Massachusetts, and installed at the Olive Branch site in 1984. The antenna has performed satisfactorily since that time.

C. ANTENNA PEDESTAL

Antenna pointing is accomplished by a Scientific-Atlanta pedestal that was modified by the in-house Control Systems Group, to meet the NEXRAD Technical Requirement (NTR) of 15 deg s^{-2} acceleration in both axes, 30 deg s^{-1} peak azimuth velocity and 15 deg s^{-1} peak elevation velocity. The mount modifications included regearing, forced-flow oil lubrication for the gear box and servo system changes.

The pedestal became operational at the Olive Branch site during the summer of 1984 with final modifications being completed during this past quarter. The antenna servo system has been performing correctly since the completion of those changes.

During the summer, extreme heat in the area of the azimuth gear box caused excessive thinning of the lubricating oil. Heat sinks were attached to the outside of the gear box with a flexible duct providing a source of cooling air from a fan placed near the base of the pedestal. This solution cured the overheating problem.

D. TRANSMITTER/RECEIVER

The test-bed uses a production line ASR-8 transmitter and receiver, on loan from the U.S. Navy, with the Lincoln-developed 'instantaneous' automatic gain control (AGC) shown in Figure II-2. After some additional filtering was added to the modulator, the transmitter met the objective of an integrated instability residue less than -50 dB.

The klystron transmitter tube failed on 5 July. Inspection showed that interelement arcing occurred within the tube, leading to a hard short circuit. A replacement klystron was secured from the FAA depot in Oklahoma City and the defective unit returned to them for rebuilding.

Although coherent oscillator (COHO) leakage into the AGC module was reduced to near-noise level, some effects from the leakage still can be noted. Removal of the fast-timing circuitry from the AGC channel should eliminate the leakage completely. A new fast-timing chassis has been constructed for that purpose. Installation should occur during the next reporting period.

E. SIGNAL PROCESSOR

1. Overview

The test-bed Signal Processor (SP) is a Lincoln-Laboratory-built system whose basic tasks include AGC normalization, clutter suppression and autocorrelation lag (0, 1, 2) estimation. The AGC is applied independently to every range cell (800 for first trip processing) for every pulse. Clutter suppression is achieved by the use of a 39-pulse variable coefficient, Finite Impulse Response (FIR) filter producing >50 dB suppression of near-stationary clutter. The three autocorrelator outputs are:

$$R_0 \propto \sum_{i=1}^N |\psi_i|^2$$

$$R_1 \propto \sum_{i=1}^N \psi_i \psi_i^* - 1$$

$$R_2 \propto \sum_{i=1}^N \psi_i \psi_i^* - 2$$

The number of pulses (N) integrated is approximately the number contained in one beamwidth of scan, which in turn is a function of the scan rate and PRF. The overall

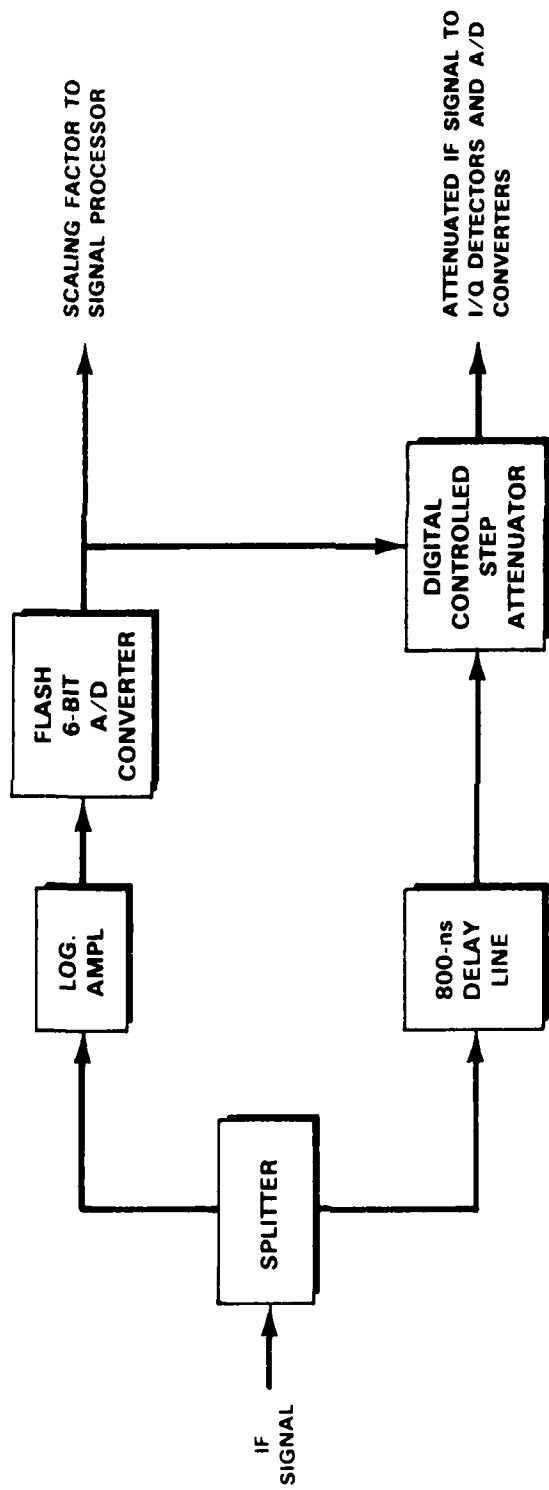
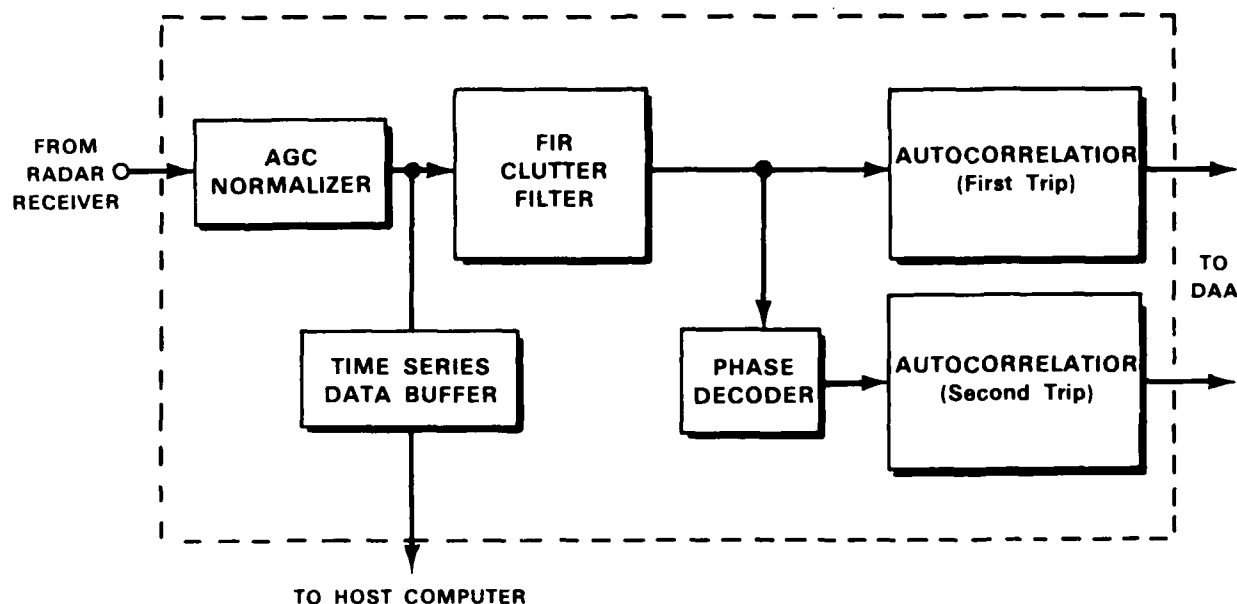

Figure II-2. Block diagram of instantaneous AGC for the FL-2 test-bed.

architecture of the SP is shown in Figure II-3. The second trip processing has not yet been implemented in the present hardware, although the phase decoder has been designed and built. No functional changes have been made to the SP system during this reporting period.

Other tasks carried out in the SP include a Pulse Interference Detector (PID), a radar-return signal simulator to produce known inputs to the SP, a Single Gate Processor (SGP) sampler for diagnostic purposes and a phase decoder to provide for decorrelating unwanted second trip radar returns.



135661-N-02

Figure II-3. Signal processor architecture.

2. Signal Processor Status

A second SP has been constructed and integrated with the development Data Acquisition and Analysis (DAA) processor and the Perkin-Elmer (P.E.) 3240 computer at the Lexington facility. This SP will provide a facility for testing SP features at the Laboratory and also provide more realistic inputs to the DAA processor at the Laboratory. This SP presently is being debugged and should become operational within the next reporting period. A new radar signal simulator has been designed and also should be completed during the next quarter.

F. DATA ACQUISITION AND ANALYSIS PROCESSOR

1. Overview

The DAA processor is a Lincoln Laboratory-built multiprocessor used to perform real-time processing of Doppler weather radar data. Figure II-4 shows a high-level block diagram of the DAA. Two DAA processor systems currently are operational. One is at the weather radar test-bed, currently in Olive Branch, Mississippi, for operational use, and the other is at the Lexington facility for hardware/software development.

A third DAA is under construction at the Laboratory. This third DAA will help alleviate conflicts arising from DAA usage for both hardware and software debugging. The core of the third DAA, a DAA chassis, a monitor board and a multiport memory board, all have been built. The multiport memory board is complete and working correctly. The chassis and monitor board still are being debugged.

One of the project's continuing goals is to make the Laboratory-based DAA as close to the test-bed DAA as possible. This similarity allows the staff to perform realistic software and hardware tests with the Laboratory DAA. Progress has been made toward realizing this goal by

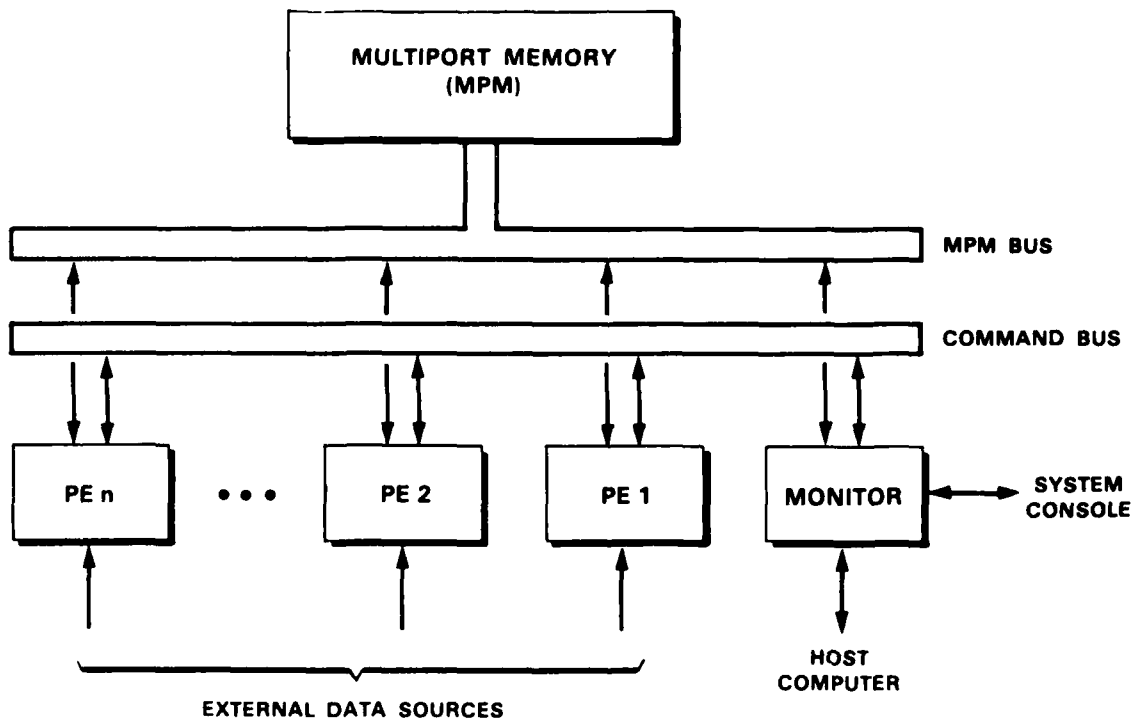

Figure II-4. DAA processor block diagram.

building an exact copy of the test-bed Input Multiplexer board. This board needs to be debugged and installed in the Lexington DAA.

2. DAA Hardware Status

Fourteen DAA Processing Element (PE) boards have been built. Testing and modifications of the PE boards to increase their speed and processing capabilities continues. Table II-1 shows the status and location of each PE board.

TABLE II-1				
DAA Processing Element (PE) Status (as of 30 September 1985)				
PE No.	Location	Revision	Status	Problem
1	Lincoln	Rev. 5	Not Working	Local Memory
2	Lincoln	Rev. 5	Not Working	Local Memory
3	Lincoln	Rev. 5	Not Working	Local Task FIFO (First in, first out)
4	Lincoln	Rev. 5	Working	
5	Lincoln	Rev. 5	Not Working	Local Task FIFO
6	Lincoln	Rev. 5	Working	
7	Memphis	Rev. 3	Working	
8	Memphis	Rev. 3	Working	
9	Lincoln	Rev. 5	Not Working	Local Task FIFO
10	Lincoln	Rev. 5	Working	
11	Memphis	Rev. 5	Working	
12	Lincoln	Rev. 5	Working	
13	Lincoln	Rev. 5	Working	
14	Lincoln	Rev. 5	Not Working	Local Task FIFO

All of the boards, except boards 7 and 8, have been updated to revision 5. Eight boards are working correctly. The remaining six boards have passed low-level exercises performed on a microprocessor-based test box and are undergoing high level tests that involve system integration.

Several improvements have been made to the high-level tests for all the DAA boards. These improvements include:

- (1) A multiport memory (MPM) arithmetic logic unit (ALU) functional diagnostic program that presents the ALU status on a Hewlett-Packard display.
- (2) A repetitive MPM memory diagnostic program.
- (3) A PE Hardware Modification Diagnostic program that presents PE status on a Hewlett-Packard display.
- (4) A new display panel for the Laboratory-based DAA that shows all of the PE and monitor board states simultaneously. This display panel is also useful as a software debugging tool.

These improvements will facilitate hardware debugging at the system level.

Efforts will continue to provide fully-functioning DAA hardware modules to support the full software system functions (a total of six PE boards, one MPM, and one Monitor board per system).

3. DAA Software Status

Software development for the DAA has centered around the components needed to support data collection operations. These components include: The computation of weather parameter estimates from autocorrelation measurements, a clutter map and the resampling of polar data to a Cartesian grid. The specific software modules are shown below.

Software Module	Purpose
Lags to Factors	Convert autocorrelation estimates to intermediate quantities
Factors to Moments	Calculate final weather parameter estimates (reflectivity, velocity, spectrum width, S/N ratio)
Clutter Map	Minimizes the display of residual clutter
Resampling	Transform polar tilt data to a Cartesian grid
Control Processing	Collection and dissemination of control information and generation of basic status display.

The data flow between these modules is shown in Figure II-5.

Presently installed in the Memphis test-bed is Version 1 of the DAA real-time software. This version provides raw 'lags' data from the signal processor autocorrelation estimates for recording. Version 2, which provides 'factors' data, also has been installed and tested and can be used to record factors data at an 8 radials/s processing rate.

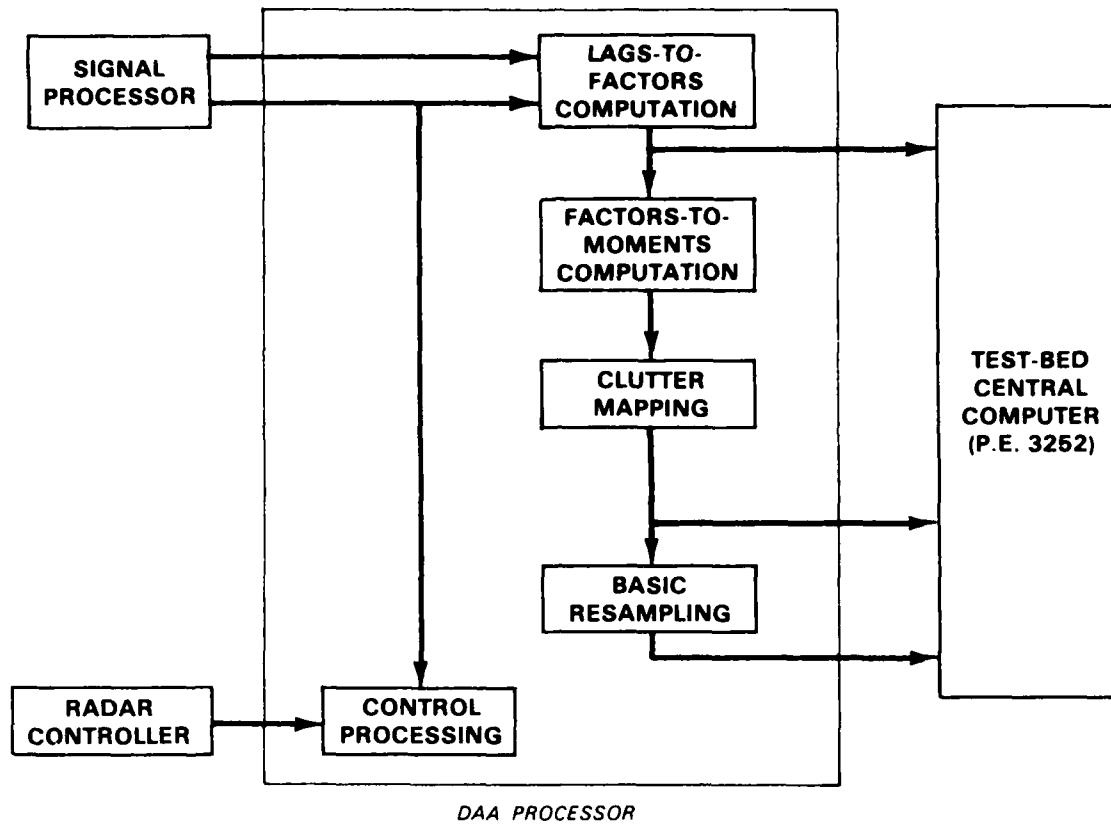

Figure II-5. DAA data flow for basic data processing.

Each DAA software processing module has to operate in 'real-time'. Table II-2 shows the timing goals for the DAA and the present processing rates for each software module.

The worst case timing scenario requires the DAA to process 37.5 radials/s while a typical timing scenario will require the DAA to process approximately 18 radials/s. The present processing rates and status of each software module are discussed individually in the sections below:

a. Lags to Factors

The latest version (Version 2) of the lags to factors code was installed in the test-bed and factors were recorded on tape. As seen in Table II-2, this version of the lags to factors code is capable of processing 8 radials/s. Analysis of the software to determine how to increase throughput revealed three areas of concern: normalization, division, and shifting required by scaling.

TABLE II-2		
Timing Considerations		
Timing Goals		
Worst Case = $1200(\text{PRF})/32(\text{N}) = 37.5 \text{ Radials/s}$		
Software Module Timing (for single processing element)		
Lags to Factors (current)		8 Radials/s
Lags to Factors (New Normalization Scheme)		24 Radials/s
Factors to Moments		Under Development
Clutter Map		55 Radials/s
Resampling	PPI	10 Radials/s
	RHI	3.3 Radials/s
New Resampling		20 Radials/s
Algorithms	PPI	20 Radials/s

A new software normalization scheme was added to the code, and timing tests indicated that the throughput increased to 24 radials/s. Future plans are to build a hardware normalizer and to divide the lags to factors code among two processing elements. Analysis of this plan indicates an increase to 31 radials/s can be expected.

b. Factors to Moments

A first pass algorithm for the factors to moments module has been designed and is undergoing refinements.

c. Clutter Map

Timing tests in the Lexington development system revealed that the clutter map editor algorithm operating on a single PE can process 55 radials/s, which is faster than required.

d. Resampling

A FORTRAN program on the Perkin-Elmer has been created that allows flexible user control of the generation, download, and display of test data radials and the resulting resampled fields. The current status is as follows:

- (a) *PPI*: Timing tests run at Lexington indicate that the PPI resampling code can process 10 radials/s. A new resampling algorithm has been developed, coded, and

debugged. Timing tests indicate that with this algorithm, the PPI resampling throughput is increased to 20 radials/s for a single PE.

(b) *RHI*: Efforts to increase the throughput of the RHI resampling code continued. These efforts included the following tasks:

- (1) Coding, debugging, and installing a program module in the RHI code that calculates the number of subdivisions necessary to resample a RHI tilt successfully.
- (2) Modifications to the curvature of the earth computational module.
- (3) Modifications to the altitude clipping module.

Timing tests at Lexington indicate that these changes increased the throughput to 3.3 radials/s for a single PE. Future plans call for modifying the RHI resampling code to use the new PPI resampling algorithm.

e. Control Processing

Monitor board software was modified to make data transfer between the Multiport Memory and the Perkin-Elmer minicomputer (P.E.), more efficient while in the direct memory access (DMA) mode.

Efforts will continue on modifying existing software modules where necessary to approach worst case real-time processing constraints. This includes dividing the lags to factors code between two processors and modifying the code to utilize a hardware normalizer preprocessor, refining the new PPI resampler algorithm, and applying the new algorithm to the RHI resampling method.

Initial investigation of the factors to moments algorithm indicates a capability for processing in real-time.

G. RADAR/ANTENNA CONTROLLER

The principal objective of the antenna control software is to achieve a fast update for weather measurements consistent with the mount and servo limitations on peak acceleration and system bandwidth. The antenna control software for the Scientific Atlanta pedestal was modified to encompass new scan patterns as well as changes in the dynamic response of the antenna mount and the servo amplifier characteristics. This software development required close interaction between the weather radar project software development personnel and the Lincoln Laboratory Control Systems Engineering Group personnel who designed and implemented the mount analog servo control system.

The control program was written in Ratfor, a preprocessor which translates a rational set of programming constructs into FORTRAN source code. While the particular Ratfor preprocessor chosen is neither the latest nor the most sophisticated version available, it is known to be bug-free and provides sufficient structure to accomplish the task.

Work this quarter focused on coding and testing a continuous azimuth rotation scan, faster sector scans and finalizing the Sun pointing mode used for system calibration. The Pedestal Control Program is now fully operational.

Several modifications have been made to the Pedestal Control Program in this quarter. Major among these are:

- (1) Improved diagnostic information for post measurement analysis.
- (2) Azimuth and elevation tachometer outputs that provide direct angular rate data now are recorded, and calibration 'constants' have been added for use with the tachometer outputs.
- (3) Faster Sector Scans have been implemented by forcing all acceleration and deceleration to occur inside the weather measurement sector.
- (4) Continuous rotation azimuth scans.

A brief description of each of these follows:

Improved Mount Diagnostic Data: Each scan sequence 'request' from the Radar Control Program that receives requests from the P.E.-3250 computer now is tagged automatically with the date and time at which the request is accepted by the Control Program before being recorded on the log tape. This facilitates locating the appropriate data on the log tape when anomalous performance is encountered.

Angular Rate Data Usage: The pedestal angular velocity is used by the Pedestal Control Program both to determine when it is safe to switch from rate mode to position mode while either stopping or moving to a specified position and to determine the direction in which to move toward a specified azimuth.

Two 12-bit A/D channels have been added to the Radar Controller Interface to allow the software to determine the azimuth and elevation rates by measuring tachometer voltages in lieu of the relatively crude velocity estimates determined by dividing the change in position by the corresponding change in time. The raw azimuth and elevation tach readings are recorded on the log tape and a scale factor, offset, and noise floor have been provided for calibration of each tach.

Faster Sector Scans: Azimuth sector scans previously were performed by accelerating and decelerating outside the data area and moving at a constant rate inside the weather data sector. Elevation sector scans were performed in the same manner to the extent possible without encountering the elevation software limits at -2 and $+92$ degrees.

Because it is not required that the scan rate always be kept constant during data collection, acceleration and deceleration may be kept inside the data area with motion beginning and ending at the data area limits. Scanning in this manner saves the deceleration acceleration time but loses some time to the elevation stepping function. The time saved while moving the swept axis is generally more than that required to move the stepped axis and therefore the overall time for a tilt usually is decreased.

By forcing all acceleration and deceleration to occur inside the weather data sector, the time required to perform an Azimuth or Elevation Sector Scan has been reduced and is now acceptable based on timing of candidate TDR, RHI, and PPI sector scans. A problem that caused downward scanning to occur at a very slow rate near zero elevation also has been corrected by the implementation of a new deceleration algorithm.

Continuous Azimuth Rotation Scan: A continuous azimuth rotation mode was requested and implemented in the current version of the Pedestal Control Program.

Before the first tilt of the first scan, the azimuth axis is accelerated to the desired rate outside the data area and azimuth motion is continuous in the specified direction until all tilts of the requested scan have been completed.

If a single scan is requested, azimuth motion is discontinued at the end of that scan; if a scan is requested to be performed continuously or for a specified number of iterations, motion is continuous between the last tilt of each scan and the first tilt of the next. While in this case the start/stop azimuth precesses in the direction of rotation from tilt to tilt, data still, however is collected over a full rotation at each tilt and the precessing is compensated for in the subsequent processing.

H. MAIN MINICOMPUTER

The Real-Time Control Program (RTCP) executes in the main P.E.-3252 minicomputer in the test-bed system (see Figure II-6). The program also, with some restrictions, can be executed in the P.E.-3240 minicomputer located in Annex II at the Lincoln Laboratory facility in Lexington, Massachusetts. The ability to execute the program on a similar computer in Lexington greatly facilitates software development by enabling it to be carried out in parallel with the operations being performed at the field site test-bed.

The principal functions presently performed by the RTCP are:

- (1) Operator control of:
 - (a) radar operations (scan sequences),
 - (b) record/playback of DAA output (weather data), and
 - (c) three-moment displays (zoom, pan, etc.).
- (2) Computer control of record/playback of DAA output data.
- (3) Display of:
 - (a) system status,
 - (b) diagnostic messages, and
 - (c) moments (weather products).

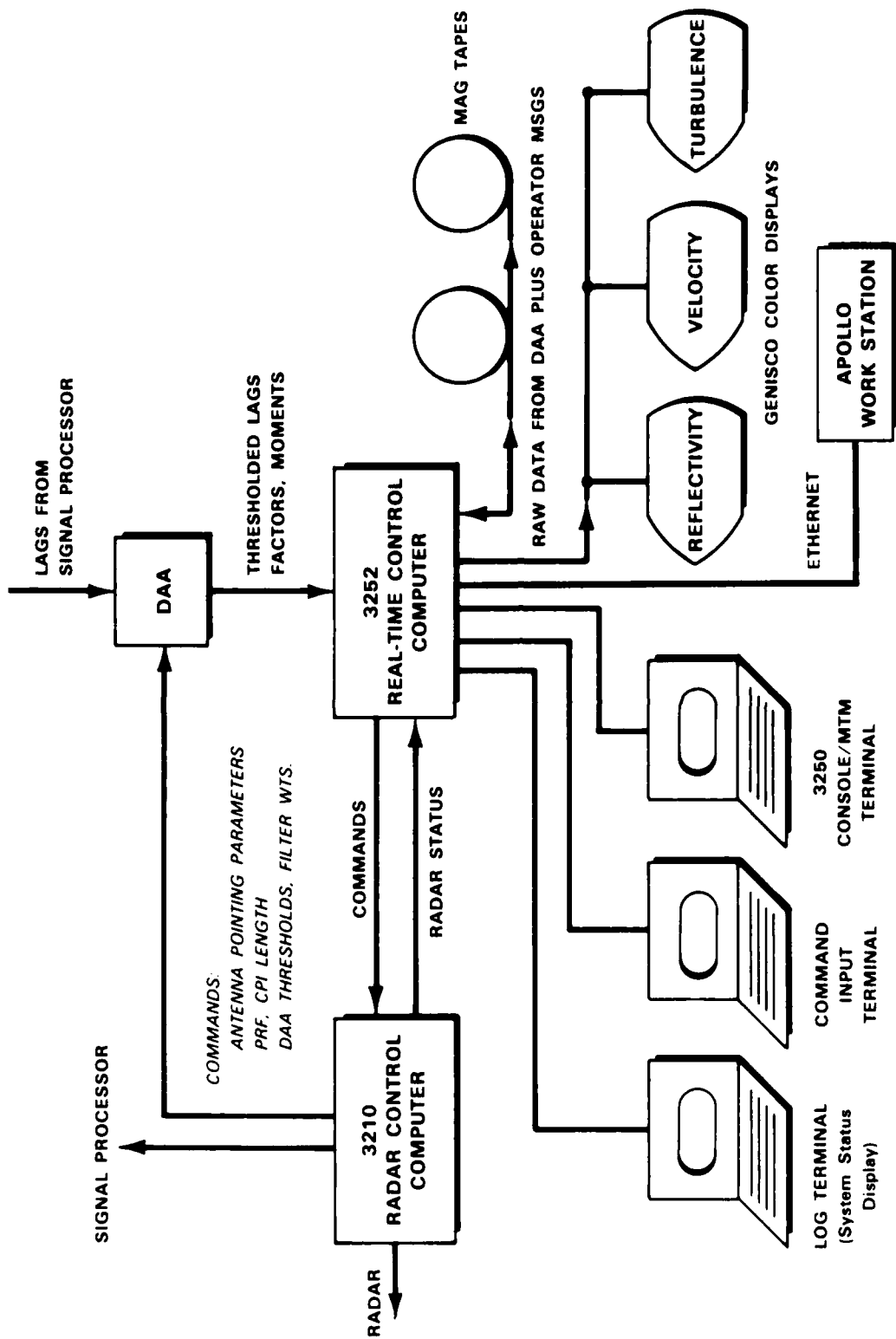

Figure 11-6. Real-time control computer and its interface.

74888-6

(4) Processing of DAA data for weather product display:

- (a) factors-moments computations,
- (b) polar-to-Cartesian transformation.

The two functions in item 4 above are interim tasks that in the near future will be performed in the DAA. This will permit a large portion of the P.E.-3252 central computer resources to be available for weather algorithms such as microburst and gust front detection, etc.

An overview of the external interfaces to the RTCP is shown in Figure II-6. The program presently receives thresholded autocorrelation lags or factors (factors are ratios of the lags) from the DAA, records the incoming data on magnetic tape, computes the corresponding spectral moments (reflectivity, mean, velocity and turbulence), and displays these moments on three color monitors.

The maximum processing load to the computer is approximately 20,000 range/angle cell/s (i.e., 800 range gates \times 25 beamwidths/s). At present, the actual data rate input to the computers is usually less than 5,000 cells/s because of recording limitations and some data thresholding in the DAA.

The present tape recording system can record between 5,000 and 10,000 spatial cells per second depending upon the degree of thresholding invoked and whether lags or factors are being processed.

A new faster data recording system presently is being configured to allow recording at the full 20,000 cell/s data rate.

The control function of the real-time program presently is implemented using the three terminals shown in the lower left hand corner of Figure II-6. The first is a dynamic display of messages generated by the various tasks in the system. The second terminal is used by the system operator to enter commands such as start/stop recording, zoom, etc., into the system. The third terminal is used by the operator to create and edit radar scan sequence command files. This distribution of control and status display over three terminals has proven cumbersome. Hence, a future task will be to simplify this interface to permit operation from a single terminal/display.

Radar control is exercised via a low-speed (9600 baud) link between the P.E.-3250 and the P.E.-3210 computers. The data link between the computers is under control of the RTCP and messages may be sent from the RTCP to the 3210 at any time. The messages to the 3210 include initialization parameters for the SP, control parameters for the DAA, antenna scan parameters for each tilt, and commands to initiate or terminate a previously specified scan.

Three separate color monitors are used to provide simultaneous displays of reflectivity, velocity, and turbulence in Cartesian coordinates. Depending upon whether the radar is scanning in azimuth or elevation, either Cartesian PPI (ground plane) or

RHI (vertical plane) displays are created. Overlays of state boundaries, mesonet locations, and aircraft location are superimposed on the Cartesian PPI displays. The displays may be both zoomed and panned under operator control.

A simplified data flow diagram of the RTCP is shown in Figure II-7. The principal tasks and their corresponding function are described below. The communication tasks are shown separately in the lower half of the figure.

- ROUTER — Manages data from the DAA, writes this data on tape, and simultaneously distributes it to the POLAR task
- POLAR — Perform lags-to-moments or factors-to-moment computation on the data derived from the DAA and resamples the resulting radial moment data into Cartesian coordinates. The output of POLAR is three resampled Cartesian images (reflectivity, velocity, turbulence) for display.
- BPD (Base Products Display) — Converts the three-moment image files generated by POLAR into pseudo-color display code for display, generates various overlays, and drives the three displays.
- TBS (Trackball server) — Positions trackball cursor on the display and computes position data.

These programs are data driven. The ROUTER task waits until the DAA has data available to send to the 3252. When the DAA data is available, ROUTER reads the data into memory, writes the previous input block of data to tape, and copies that block into a data queue for subsequent processing by the POLAR task.

The POLAR task runs asynchronously with respect to ROUTER. It polls the data queue being filled by ROUTER and if data is available, it performs the required processing. If the queue is empty, POLAR suspends itself briefly before again examining the status of the queue.

The BPD task converts each image to pseudo-color on a pixel-by-pixel basis, does zooming and panning of the resulting display images and outputs them to the corresponding color display monitors. BPD also generates and outputs overlay images of state boundaries, mesonet locations and aircraft beacon responses on all three monitors. The remaining tasks deal exclusively with operator control and internal communications.

I. TEST-BED ENHANCEMENTS

The FL-2 test-bed functioned well enough to gather a significant number of data tapes (~400) on Memphis area low-altitude wind-shear events during the past reporting period. Several minor fixes and improvements were incorporated during this time. However, in order to increase

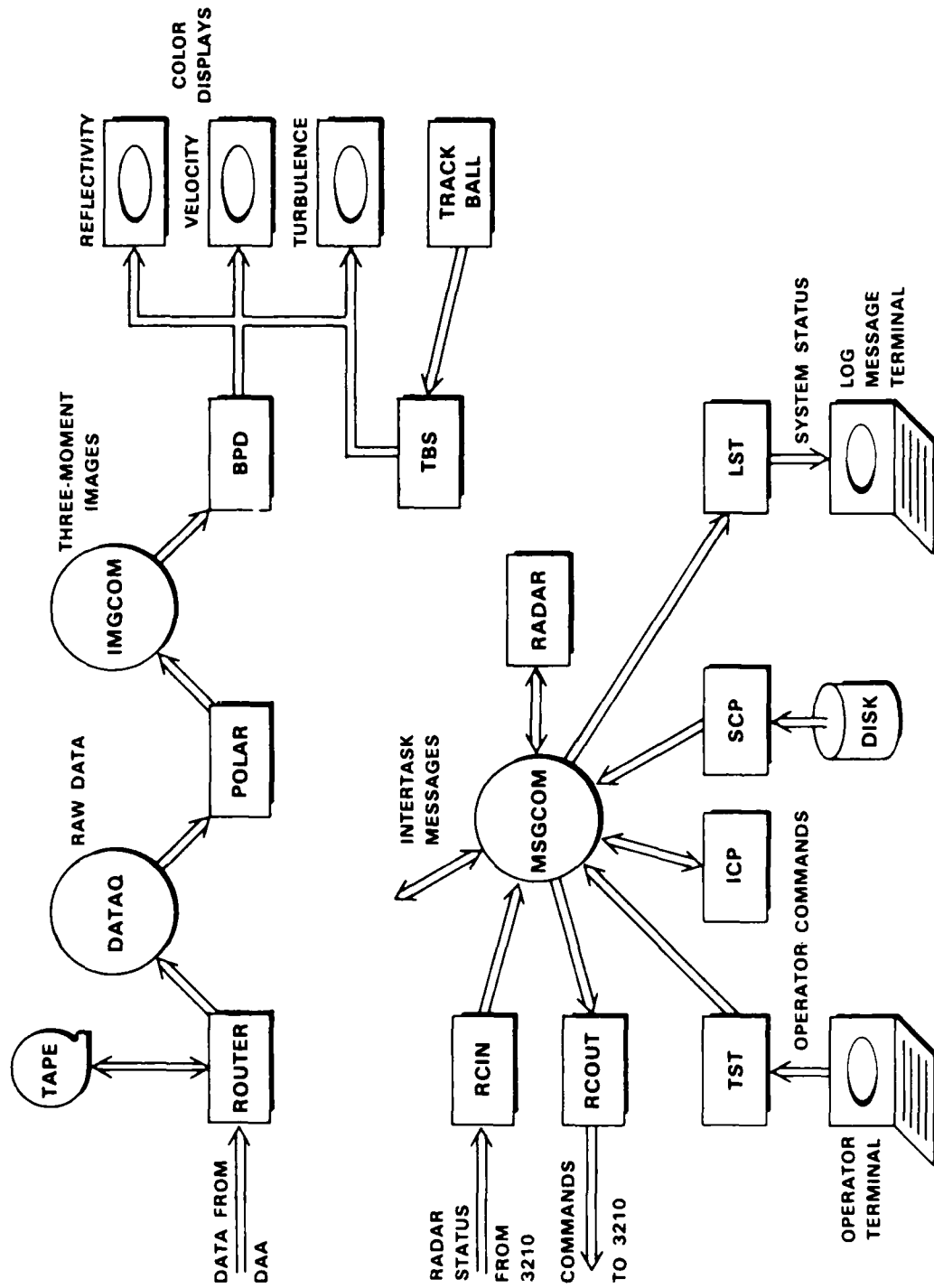

Figure 11-7. Real-time program data flow.

the radar volume scan rates and provide faster system calibration, a number of major improvements are planned for implementation during the coming months. Listed below are some of the key items to be accomplished.

- (1) New Apollo display/control work stations.
- (2) Increase PRF and scan rates.
- (3) Streamline the diagnostic and calibration procedures.

1. Apollo Displays

As was described in the last quarterly report¹, present plans call for incorporating Apollo work stations with color and monochrome monitors into the FL-2 test-bed for product display and control function usage. Figure II-6 shows the overall test-bed display configuration for 1986.

Software development efforts related to the test-bed work station network proceeded during the quarter with two primary areas of emphasis: the capability for process-level communications among the P.E. superminicomputer and the Apollo work stations, and development of weather product display and data management capabilities for the work stations.

The real-time nature of the FL-2 test-bed environment necessitates a stream-oriented, process-level communications link between the P.E. superminicomputer and the Apollo work stations. This capability is intrinsic to the UNIX-like operating system employed by the Apollo devices. The P.E., however, does not inherently possess this capability.

The Internet Systems Corporation of Sunrise, Florida, markets an Ethernet communications package for the P.E.s that utilizes Transmission Control Protocol/Internet Protocol (TCP/IP) protocols. That software typically is provided with high-level interfaces for file transfer protocol (FTP) and remote login (TELNET). Internet has been granted a contract to enhance that software package by providing the process-level TCP/IP communications interfaces that are required. The Weather Project has shipped an Apollo DN-550 color work station and a DSP-80 server with an Ethernet controller to the Internet installation, so that end-to-end testing of the software may be performed prior to delivery.

The initial weather product display and management software for the Apollo work stations has been subcontracted to Dr. John Anderson at the University of Illinois. Dr. Anderson has been provided with an Apollo DN-550 color work station. An initial display capability has been implemented and progress is continuing in the development of the data base management software. We hope to have the new display work station capability operational in time for the Cooperative Huntsville Meteorological Experiment (COHMEX) operations next summer in Huntsville, Alabama.

2. Increase PRF and Scan Rates

The present system is limited in PRF scan rate by the data recording capacity of the existing 1600 bpi 75 ips (interest per second) nine-track digital tape recorders. Three steps are

planned to alleviate this constraint and allow data taking at the full NEXRAD/TDR potential load of 1500 PRF and 25/s rotation rate.

Step one will be to record 'factors' (i.e., compressed ratios of lags) instead of lags. This requires that the DAA do the lags-to-factors processing internally instead of passing the lags to the central computer for processing. This phase of work has been completed and is in final checkout.

The second step will be to do the factors-to-moments processing in the DAA, thus further relieving the central computer resources for other tasks such as algorithm computation. This phase is targeted to be completed by the time the radar is operational again in Huntsville, Alabama, in March 1986.

The third step involves replacing the 1600 bpi tape drives with dual density 1600/6250 bpi/125 ips drives. This not only will remove all future restrictions on data recording capacity but also will provide for fewer tapes to be recorded during a normal recording session. The new tape drives are scheduled to be delivered in February 1986.

3. Streamline Diagnostic and Calibration Routines

A number of special purpose diagnostic and calibration routines have been written as the need arose during construction and checkout of the basic FL-2 radar. As the system has grown and matured during the past year, it often has become necessary to modify or reconfigure these for various other checkout tasks. Documentation of these programs is sketchy or nonexistent making it cumbersome for new people to make efficient use of them.

During the hiatus between closing down operations at Memphis and starting up again in Huntsville, it is hoped that the existing programs can be restructured, enhanced, and combined with necessary new programs to provide a comprehensive set of diagnostic/calibration routines in an efficient user-friendly package.

III. SITE PLANNING AND OPERATION

A. MEMPHIS SITES

1. Lincoln Radar Site

No changes were made to the test-bed at the Olive Branch, Mississippi, site during the quarter. However, specifications for site breakdown and restoration to a soybean field after Thanksgiving were prepared and sent to various contractors. The contracts for the site work will be let early in the next quarter with the work completed by the end of January 1986.

2. University of North Dakota (UND) Site

The University of North Dakota completed its radar operations in the Memphis area on 23 September 1985. The radar was packed and shipped back to Grand Forks, North Dakota, for their winter operations. The antenna tower, provided by Lincoln Laboratory, was packed in preparation for its move to Huntsville, Alabama, where it will be used during the 1986 Cooperative Huntsville Meteorological Experiment (COHMEX).

3. Mesonet Sites

No changes were made to the mesonet sites during the quarter.

B. HUNTSVILLE SITE PLANNING

Huntsville, Alabama, has been chosen as the 1986 FAA/Lincoln Laboratory Operational Weather Studies (FLOWS) experimental site. During the month of June and July (and possibly parts of May and August) 1986, the FLOWS effort will be joined by two other large data collection efforts in the Cooperative Huntsville Meteorological Experiment. The other projects are MIST (Microburst and Severe Thunderstorm Project), proposed and organized by T. Fujita and R. Wakimoto, and SPACE (Satellite, Precipitation, and Cloud Experiment) coordinated by J. Arnold at the NASA Marshall Space Flight Center. This mutual effort will provide a unique opportunity for Lincoln Laboratory and the FAA to utilize multiple Doppler radars, several aircraft, special surroundings, and surface data from nearly 100 mesonet stations to help define the low-altitude wind-shear characteristics in the southeastern portion of the U.S. as typified by the Huntsville area.

In addition to the FL-2 radar (presently located near the Memphis, Tennessee, municipal airport), a second Lincoln-developed radar (FL-3) has been proposed to be located in the Huntsville area during 1986. FL-3 will be used to evaluate enhancements to the weather detection capability of the ASR-9 radar weather. If FL-3 becomes operational in time, it will participate also in the COHMEX experiments.

The two site locations for the FL-2 and FL-3 radars are shown in Figure III-1. These locations are approximately 1-1/4 miles from the existing ASR-7 and proposed ASR-9 locations. The sites have been selected and are under contract from the landowners.

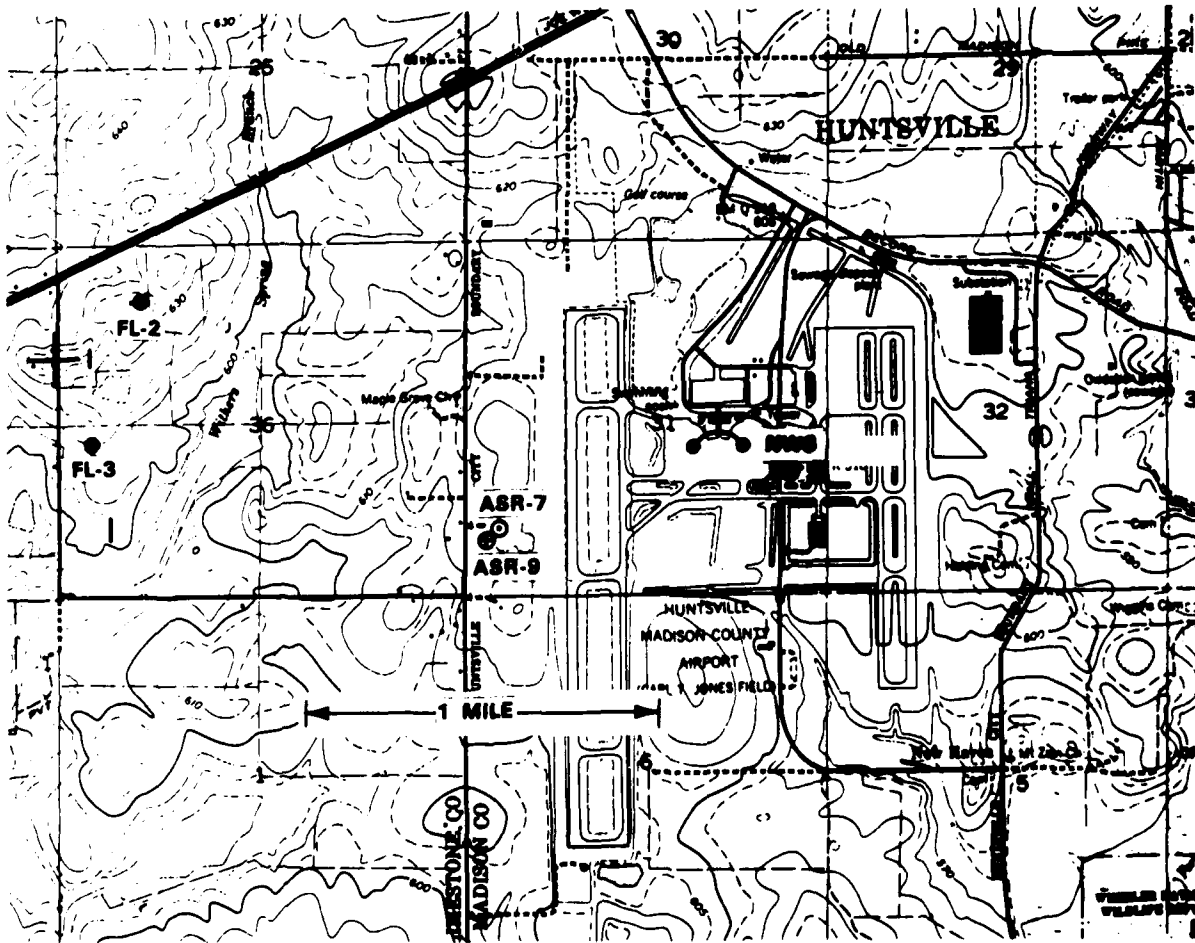

74888-8

Figure III-1. Huntsville, Alabama, area site map.

Both sites have been laid out and construction level drawings produced for contractor use in grading, road building, foundation construction, and electrical distribution. Contractor responses to the request for proposals are due in mid-November with construction due to be completed by the first of the year.

Present plans are to stop all data taking operations on 25 November 1985 and start disassembly of FL-2 in Memphis. Depending on the weather, the Memphis site will be closed down by 15 December. Also depending upon the weather, plans call for the reassembly of the radar in Huntsville to start on 6 January 1986 so that FL-2 measurements in Huntsville can commence in March.

C. MEMPHIS OPERATIONS

1. Lincoln Radar Measurements

The FL-2 radar was operational throughout most of the quarter, collecting data during 44 periods on 34 days for totals of 145 h, 11 min, and 380 data tapes. The longest operational period occurred on 15 and 16 August when the remnants of Hurricane Dannie came through the mid-South region. We operated most of the time from 0800 CDT on the 15th through 1637 CDT on the 16th.

July through September proved to be very active months for producing gust fronts and microbursts. A total of 68 microbursts or wind-shear events and 36 gust fronts were detected (compared to 25 and 42, respectively, from April through June). No microbursts at all were detected during the last three weeks of the quarter, but there were four gust fronts.

One of the interesting new events seen during the quarter was ring gustfronts. These gustfronts often formed around slow-moving microbursts, emanating outward from the initial center of the downburst location. Occasionally these ring gust fronts were quite long lasting, sometimes persisting even after the parent cell had disappeared from the radar display.

2. Mesonet Operations

Lincoln Laboratory continues to operate a 30-station mesonet in the Memphis area. These stations record 1-min averages of temperature, relative humidity, barometric pressure, wind speed and direction, and precipitation. At 30-min intervals, the data are telemetered to a GOES satellite and then transmitted to Synergetics International Corporation, Boulder, Colorado, for recording to tape. Lincoln receives the taped data approximately weekly.

The mesonet sites operated routinely during the quarter, but there were a number of minor problems. Wind sensors at a couple of stations needed the O-rings on their shafts replaced. As they age, these rings crack and break, causing the inner and outer shafts to rub, producing poor measurements of winds at low to moderate wind speeds.

Temperature and humidity sensors also needed replacing at a couple of stations during the quarter. Humidity sensors tend to become contaminated at some stations, resulting in poor humidity measurements. As they cannot be cleaned, the sensors must be replaced.

Barometric pressures continue to be problematic at times for some stations. Stations 2, 4, and 13 began giving erroneously high pressures about the middle of the quarter. The cause of this may be partly related to the instruments themselves and partly to the processing electronics at each station. Changing the data collection platforms (DCPs) at two of these sites seemed to take care of their problems. At the third site, however, this did not help.

Another problem with the pressure data was discovered during the quarter. This one shows up as very noisy pressure estimates (only at some stations) whenever the wind is low. With perfectly calm winds, the pressure traces are fine. When the wind is just a couple of meters per second, the pressures become quite noisy. As the wind speed increases, the noisiness decreases (but does not disappear). The cause of this variation is as yet unknown but thought to be somehow induced by the processing done within the DCPs. Further study of this problem is under way.

Finally, one station was damaged by lightning on 10 July but was repaired and operational by the next day, while another had the cable running from the rain gauge to the main station cut by the lawnmower of a well-intentioned land owner.

3. Low-Level Wind-Shear Alert System (LLWSAS) Data Recording

Lincoln has been recording the Memphis International Airport Low-Level Wind-Shear Alert System data continuously since the summer of 1984 on a Lincoln-developed recording system. Site personnel go to the Memphis tower weekly to change data tapes. The LLWSAS recording system operated reliably throughout the quarter.

4. UND Radar Site Operations

The University of North Dakota operates an Enterprise Electronics Corporation C-band Doppler radar with a Sigmet Corporation signal processor in support of Lincoln Laboratory's operations in the Memphis area. This radar is located about five miles south of the Memphis International Airport.

Coordination of scanning between the FL-2 and UND sites is accomplished by radio with telephone available as a backup. The data tapes from the UND measurements are copied on the FL-2 site P.E. computers. The original tapes are sent to UND and the copies to Lincoln for subsequent analysis.

The UND radar operated throughout the period at approximately the same times as the FL-2 radar. They collected 115 tapes on 28 days of operation totaling 101 h, 45 min. The last operational day for the UND radar was 23 September 1985. It since has been shipped back to Grand Forks, North Dakota, for their winter operations.

5. Aircraft Support

The UND Citation (NEXRAD1) aircraft returned to Memphis on 30 July and stayed until 19 August. This aircraft is equipped with;

- (1) a comprehensive meteorological sensing package (temperature, dew point, liquid water content, radiometers, cloud droplet spectrum, ice crystal and water drop measurements, icing rate, and cloud photographs),
- (2) turbulence sensing equipment (INS, 3-axis accelerometer, and differential pitot tube), and
- (3) automatic cameras on both sides of the aircraft.

Real-time control of the aircraft during experiments is accomplished by VHF radio discussion between the FL-2 site personnel observing real-time displays (with aircraft positions shown as an overlay to turbulence, reflectivity, and Doppler velocity maps) and UND personnel aboard the aircraft. The aircraft data tapes are being checked and copied at UND and will be shipped to Lincoln for subsequent analysis.

During the quarter, NEXRAD1 made nine flights totaling 23 h, 33 min, in support of our operations, primarily flying into regions where turbulence was detected on the radar. In addition to turbulence measurements, however, we succeeded in getting NEXRAD1 to penetrate gustfronts on two separate days and also a microburst. This latter was particularly noteworthy. On this flight, the aircraft made several passes through a microburst at about 2500 ft altitude. On one of the passes, it lost 500 ft of altitude and encountered a downdraft of about 50 knots. This data set already is being examined at Lincoln and should provide valuable information about the workings of microbursts and the hazards they pose for aircraft.

6. Additional Weather Data

The National Weather Service daily weather maps and GOES satellite image data are received and archived daily at the site. Soundings (from Little Rock, Arkansas; Jackson, Mississippi; and/or Nashville, Tennessee) and other meteorological information are obtained from WSI Corporation and used in making the daily forecasts and weather outlooks. Additionally, the UND site personnel are preparing detailed meteorological summaries for each day on which operations are conducted.

IV. EXPERIMENTAL DATA REDUCTION AND ALGORITHM DEVELOPMENT

A. PERKIN-ELMER (P.E.) COMPUTER SYSTEMS

The system configuration has been stable over the quarter, with both machines possessing two 474 Mbyte Fujitsu disk drives, two dual density (800/1600 bpi) tape drives, and eight Mbytes of main memory. Both P.E.-3240 computer systems experienced heavy use during this quarter. While the machines exhibited symptoms of overloading on occasion, hardware problems were not a limiting factor. It should be noted, however, that tape drive problems overwhelmingly dominated the hardware problems experienced.

The Versatec electrostatic printer/plotter (V80) finally has been repaired. What was thought to be a driver problem (I/O errors followed by system 'hangs') has turned out to be a hardware problem in the V80 itself. The plotting mode is now in regular (sometimes intensive) use, with occasional print operations being performed on the unit. Part of the reason for the delay in pinpointing the hardware problem was that our V80 maintenance agreement is with P.E., and the local office has no previous experience with this unit.

The data analysis effort has been seriously hampered by an inadequate computational capability for software development and for batch processing of the experimental data. It was concluded that the improvements needed to meet the FAA schedules would necessitate:

- (1) upgrading of the P.E. used for data analysis to have greater memory and additional arithmetic processing units (APUs), and
- (2) a network of highly capable engineering work stations with multiwindowed bit mapped displays, 68020 CPUs or the equivalent, several megabytes of RAM and access to at least a gigabyte of online disk storage.

The work station network will communicate with the P.E. computers over an Ethernet so that data and/or programs can be transferred easily between the various systems. Discussions were held with various work station vendors and P.E. to assess the various options. Requests for quotations will be issued early in the next quarter and the orders should be placed by December 1986.

B. RADAR DATA ANALYSIS SOFTWARE DEVELOPMENT

The Lincoln Laboratory radar data analysis software development effort centers around a compact, highly versatile common format tape (CFT) for radar data and an equally versatile format for use with data that is naturally described in a Cartesian (CAR) coordinate system. A series of translators allows conversion of radar data obtained in a variety of formats in CFT; then all the utilities and analysis programs developed to date can be used to study that data. This philosophy allows us to accept data in any new format with little extra effort, and insures that the further development of common format utilities widely benefit the entire project.

Progress this quarter on radar data analysis software development was focused on four general categories: translators to produce Common Format (CFT) radar data tapes, utilities to allow analysis of CFT data including work on the multiple Doppler analysis program, graphics capabilities for display of the analyses, and continued software maintenance.

1. Translators

A translator from University of North Dakota (UND) radar format to the Lincoln Common Weather Radar Data Format has been implemented. This is basically a modification of the UND to Universal format translator written by UND, with corrections and enhancements. This translator is capable of translating reflectivity, velocity, spectrum width, and signal-to-noise ratio for both PPI and RHI scans. By modifying the translator to output CFT data directly, rather than intermediate Universal data, processing time per tape has been halved.

A mature version of the FL-2 test-bed radar to CFT translator has been released. This translator is much faster (and more correct) than the original. Part of the difficulty with this particular translation process stems from the necessity to compute moments from lags, and the fact that some data is lost during the real-time recording process. It is expected that this translator will be modified as the capabilities of the real-time software and hardware are improved.

2. Utilities

The RESAMP program, which resamples tilts into Cartesian fields, has been updated. It now has the ability to threshold products against a signal-to-noise field. Future enhancements will take advantage of the changes in CAR.

A program for synthesizing three-dimensional wind fields from multiple Doppler radar data has been implemented. This program is capable of combining data from as many as seven radars, and providing a full wind field in the Lincoln Cartesian format. Use of this program requires considerable computer resources, both in memory and CPU time.

Enhancements to the BSCAN program, which prints out radial data in range-vs-azimuth tabular format, have continued. The purpose of these modifications is twofold: to improve program speed, and to improve user options and interaction.

3. Graphics

The capability for examining CAR data graphically is now quite mature. The program CARGRAF is capable of displaying Cartesian data as contour levels, or as fields of vectors, or both simultaneously. Output from this program is in the form of NCAR metacode, for which translators have been written both for the Tektronix 4015 terminal and the Versatec V80 plotter.

4. Software Maintenance

There is a fine line, in some cases, between 'software maintenance' and 'enhancements'. It has been found consistently that significant amounts of time are spent each quarter maintaining existing software, even if such maintenance cannot truly constitute program enhancement. The Weather Project computer programmers currently support many (perhaps hundreds of) lines of Fortran code; keeping this amount of software working in a dynamic computer, user, and specification environment is a major effort.

It so happened this quarter that, for nearly all affected programs, desired enhancements coincided well with maintenance needs.

C. MESONET/LLWSAS DATA ANALYSIS

The wind data, continuously collected by the mesonet and LLWSAS networks, will be compared with Doppler radar data collected during thunderstorms. The results will be used to (1) confirm low altitude wind-shear (LAWS) and other possibly hazardous weather events detected by the radar, and (2) provide an indication of undetected wind-shear events. The additional meteorological data collected by the network will be used to diagnose the relationship between the temperature, pressure, relative humidity, rainfall, and winds during these events and thus to gain a better understanding of the causes and circumstances of low altitude wind shear.

A software package consisting of many different programs to process and analyze mesonet and LLWSAS data has been refined to eliminate inefficiencies (especially in the data I/O) and then implemented. The data from both mesonet (30 stations) and LLWSAS (6 stations) is translated into our Common Instrument Data Format (CIDF) and all other programs and allows us to confine the input format for analysis programs to CIDF and thus to be able to accept data in any new format with little extra effort.

With this refined software package and the addition of a few other analysis programs, we were able in this third quarter of 1985 to analyze more in depth the 49 microbursts (which was the preliminary estimate) that impacted the mesonet stations during the 1984 data recording period. We found these numbers to be overestimated. It appears that there were approximately 61 times in which an individual station detected true microbursts. This is about 33% less than the previous 102 estimated cases where an individual station was impacted by a microburst. Also, the actual number of microbursts has decreased to less than 30 (40% less than the original estimate) for 1984.

An in-depth analysis was performed on approximately 45% of the 1984 microbursts. This analysis involved checking the full synoptic and upper air situations as well as looking at various atmospheric stability parameters to see if any relationship could be found throughout the various cases that would suggest some type of large-scale pattern for microburst development. The results of this study along with other topics regarding the Memphis, Tennessee, mesonet will appear in a report that now is being compiled by M.M. Wolfson, J.T. DiStefano, and B.E. Forman.

During this quarter, some key radar detection issues were assessed using the mesonet data. The proximity of rain cores to microburst centers help to give confirming evidence of shear-based detection. The wet vs dry microburst signature also shows up clearly using mesonet data. These issues will help give support to the radar data during the whole 1985 data collection season. One issue that we found could not be resolved by mesonet data alone is that of microburst symmetry due to insufficient spatial resolution of the mesonet data.

Meanwhile, the translation of 1985 mesonet and LLWSAS data continues, and the search for microbursts that impacted the mesonet during 1985 is also under way.

D. LOW-ALTITUDE WIND-SHEAR (LAWS) DETECTION ALGORITHM DEVELOPMENT

The low-altitude wind-shear (LAWS) detection algorithm development effort is aimed at producing an automatic procedure for recognizing hazardous wind-shear events from Doppler weather radar measurements. Preliminary real-time algorithm testing will take place during the 1986 experiment at Huntsville, with a major real-time operational demonstration scheduled for Denver in 1988.

Figure IV-1 illustrates the general approach taken to the detection problem. In this approach, the various radar observable features that are thought to indicate the presence of a microburst are computed, then used to form a final hazard warning decision. The low-altitude features (divergent outflow, reflectivity maxima, etc.) are available in both on- and off-airport siting scenarios, and are directly linked to the actual hazard to aviation. The upper altitude features (rotation, convergence, sinking core), are only available when the radar is sited away from the region to be protected, and serve more as precursors to the outflow event than as an actual indicator.

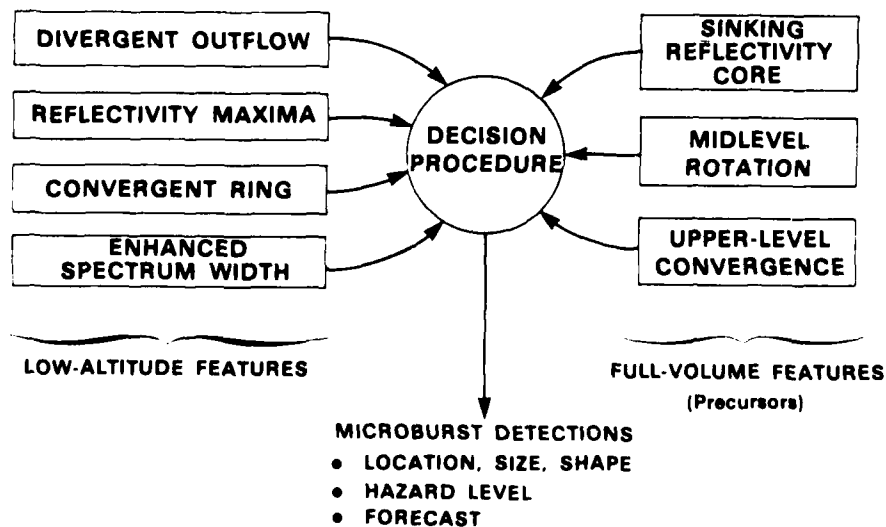

Figure IV-1. General microburst detection algorithm.

Figure IV-2 shows the status of the various feature calculation modules, in both the 'analysis' and 'real-time' contexts. Since the details of the procedures for calculating these features is an area of active investigation, flexible utilities must be available for experimenting with alternative techniques. Once effective techniques have been obtained, they must be implemented in a form that is amenable to operational execution in the FL-2 test-bed system.

FEATURE	ANALYSIS UTILITY	REAL-TIME IMPLEMENTATION
VELOCITY:		
DIVERGENT OUTFLOW	OPERATIONAL	OPERATIONAL
ROTATION	OPERATIONAL	IN PROGRESS
CONVERGENCE ALOFT	OPERATIONAL	IN PROGRESS
CONVERGENT RING	—	—
REFLECTIVITY:		
SURFACE MAXIMA	OPERATIONAL	—
SURFACE GROWTH	IN PROGRESS	—
FALLING CORE	IN PROGRESS	—
TURBULENCE:		
SURFACE MAXIMA	OPERATIONAL	—
ENHANCED RING	—	—

Figure IV-2. Status of feature calculation techniques.

The divergent outflow feature has received the most attention to date, and an initial algorithm has been implemented. Figure IV-3 gives a block diagram of this procedure, which begins by smoothing the measured radial velocity information and calculating an estimate of the radial shear of the radial velocity. Segments of positive radial shear (i.e., divergence) then are located, and associated into two-dimensional regions of significant divergence. The determination of 'significance' is based on threshold tests of the length and velocity change over each segment.

Initial experience with this algorithm has been very encouraging. Figure IV-4 shows the output of the algorithm (the region of perceived divergence) superimposed on a dual-Doppler windfield. The windfield was obtained from coordinated measurements of the FL-2 and UND radars on 26 June 1985, using a multiple-Doppler wind synthesis utility that has been implemented at Lincoln. The figure shows the windfield as a set of vectors, with reflectivity contours labelled in dBz. The large rectangle surrounding the outflow region was determined automatically from the FL-2 measurements using the algorithm of Figure IV-3. This result shows the algorithm identifying the outflow region quite well. Work is under way to apply the algorithm to numerous cases to refine and characterize its performance.

74888-10

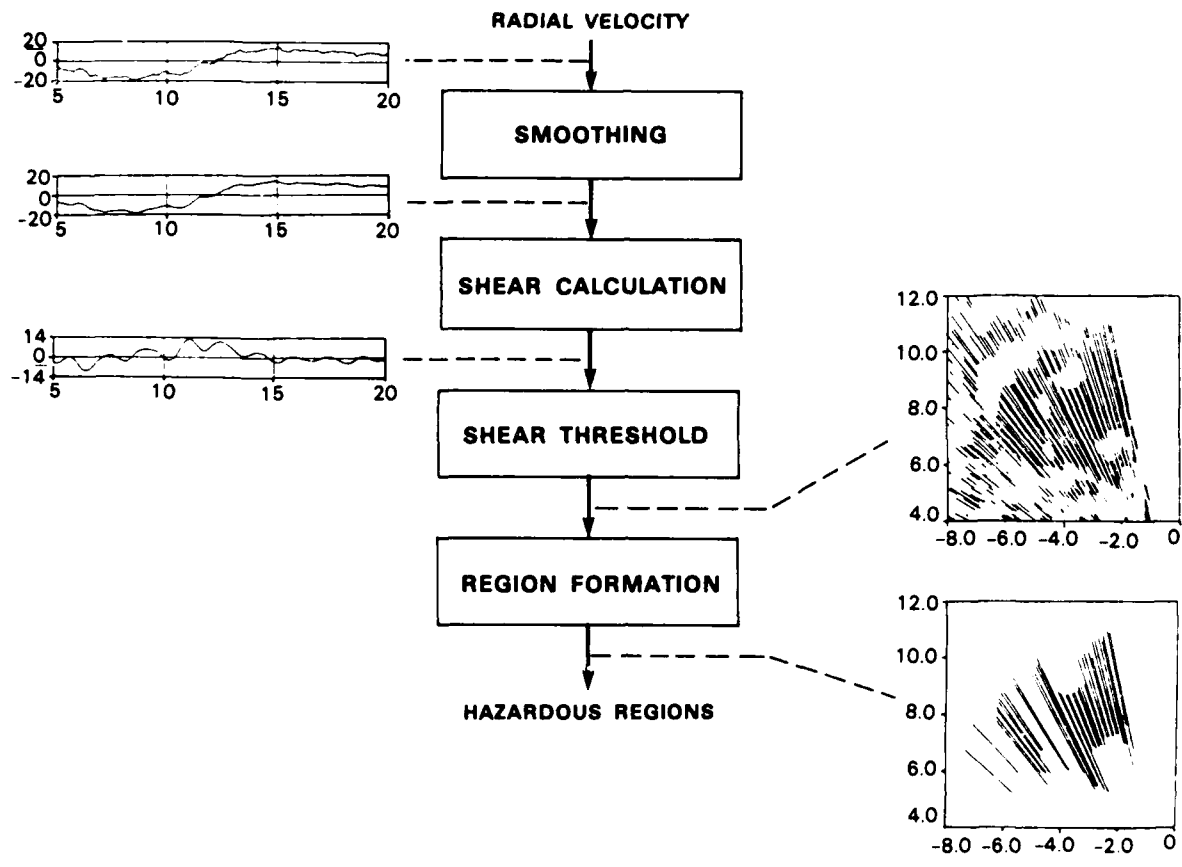

Figure IV-3. Divergent outflow algorithm.

During the next quarter, additional feature calculation modules will be implemented and applied to existing microburst cases. For each characteristic, the following parameters must be determined:

- spatial size (area)
- altitude and location
- magnitude of feature value
- dependability as indicator or precursor
- variation of characteristics with time
- spatial and temporal relation of feature with region of hazard

To assist in the determination of these characteristics, data from the FLOWS 1985 collection period will be used, along with all appropriate data available from the JAWS and CLAWS

74888-12

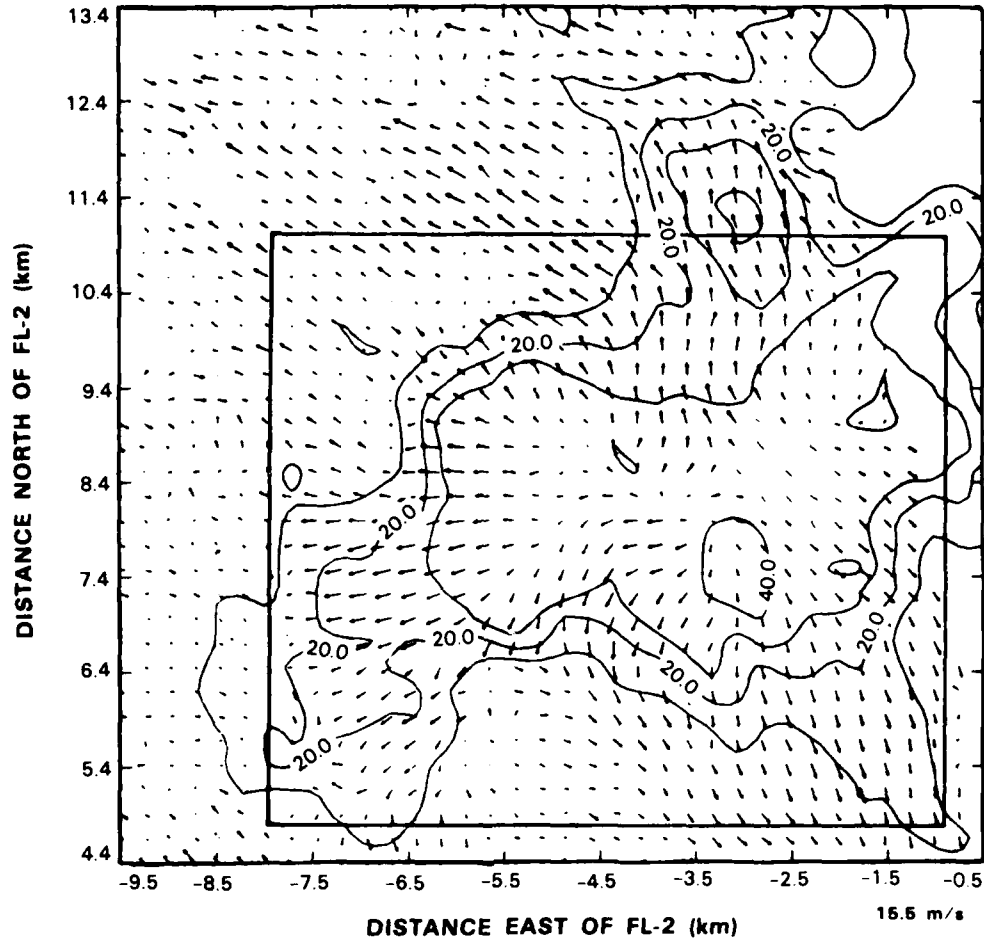

Figure IV-4. Winds/dBz 1841Z 26 June 1985 — Hickory Ridge Microburst.

projects. The use of JAWS and CLAWS data in the characterization of automatic algorithm is complicated by:

- (1) lack of upper-altitude information in the JAWS scan patterns
- (2) lack of clutter filter in both sets, and
- (3) lack of any edited cases from CLAWS.

A preliminary examination of several cases will be required to assess the ability of JAWS and CLAWS data to provide adequate information for algorithm development and performance assessment.

E. TURBULENCE DETECTION ALGORITHM ASSESSMENT

The turbulence detection algorithm work during the quarter focused on completing the analysis of data from the 1983 coordinated Doppler weather radar-aircraft experiments in the Boston, Massachusetts, area. The principal objective of the current analysis is to determine how accurately the current NEXRAD spectrum-width-based turbulence algorithm together with the layering algorithm required to generate turbulence maps [for distribution by the Central Weather Processor (CWP)] estimates the turbulence encountered by an aircraft.

Analysis of the remaining flights from 1983 were completed and preparation of a project report describing the results commenced. The results were quite similar to those reported in the previous Quarterly Technical Summary¹:

- (1) The radar estimates of the current NEXRAD turbulence indicator, kinetic dissipation rate ($\epsilon^{1/3}$), generally far exceeded the estimates based on aircraft data. The $\epsilon^{1/3}$ provided by the current NEXRAD algorithm^{2,3} are generally larger than those provided by an earlier, simpler algorithm by Labitt².
- (2) The aircraft estimates of $\epsilon^{1/3}$, whether based on pitot tube static pressure or vertical acceleration variances¹, generally suggested considerably higher levels of turbulence than did the pilot reports or aircraft vertical accelerations.
- (3) The derived gust velocity values inferred from the aircraft vertical acceleration measurements¹, underestimated the moderate turbulence encountered by the aircraft.
- (4) The vertical and horizontal spatial averaging required to generate the desired CWP spatial layers (e.g., 4 km \times 4 km resolution in horizontal plane with vertical thicknesses of 3 to 8 km) occasionally worsened the agreement between radar and aircraft data, but did not appear to be the principal contributor to the discrepancies.

It should be noted that the generally light turbulence (e.g., vertical accelerations less than 0.3 g) was encountered in the bulk of the flights with the peak vertical accelerations less than 0.75 g (corresponding to moderate turbulence). Most of the previous published reports on turbulence detection using Doppler weather radars have focused on case studies where severe turbulence was encountered by the aircraft.

The high false alarm rate for the current NEXRAD turbulence detection algorithm suggested by these results has prompted a re-examination of some of the basic assumptions used in deriving the algorithm. At the end of the quarter, work commenced on analyzing the spatial spectra of the aircraft-encountered turbulence to see to what extent Kolmogorov's low end spatial isotropy appears to hold for these particular storms. A number of inconsistencies were found in the aircraft velocity data, and discussions will be held with the University of North Dakota next quarter to resolve these issues.

These studies also have highlighted the need for a more careful assessment of the aircraft dynamics in developing an operationally useful turbulence product. We plan to hold discussions with aerodynamics experts over the next six months to better understand the difference between the Citation pilot reports and the turbulence severity scales suggested in the literature^{5,6}.

F. CLUTTER ENVIRONMENT ASSESSMENT

Efforts have been taken to quantify analytically the effect of a clutter map filter (CMF). This filter takes advantage of the high radar resolution at close range relative to the size of the weather phenomena of concern and the discrete nature of large clutter sources. In particular, a stored spacial map of the clutter residue power is used to edit the range gates that are translated from polar form to a displayable Cartesian form. Close to the radar, there are many range gates per Cartesian square due to the small cross range extent of a radar range gate. The distributed nature of the weather target allows the deletion of some range samples within a Cartesian grid cell* without significantly affecting the weather estimates. Therefore, the CMF can be viewed as a spacial threshold for the detection of weather signals. Figure IV-5 demonstrates the large number of range gates that are included in a resampled estimate. In this example, the beamwidth was 1 degree with range gates spacing of 120 meters and Cartesian grid cell dimension of 400 meters.

The minimum detectable signal within a Cartesian square is defined by the smallest range sampled threshold within that same square. Therefore, the clutter residue from a CMF for a Cartesian sample is equal to the lowest range sampled clutter value within that square sample. The net improvement using a CMF can be quantified by comparing the average clutter level to the minimum clutter level within a Cartesian bin.

An analytical assessment of the effect of a CMF can be obtained using statistics of extremes. Each range sampled clutter value can be viewed as a sample from an independent random process with a distribution function $P(\cdot)$.

* The discussion here focuses on a Cartesian resampled output field. However, the concept can be applied as well to polar data provided the algorithm that operates on the data can tolerate missing data values along a radial.

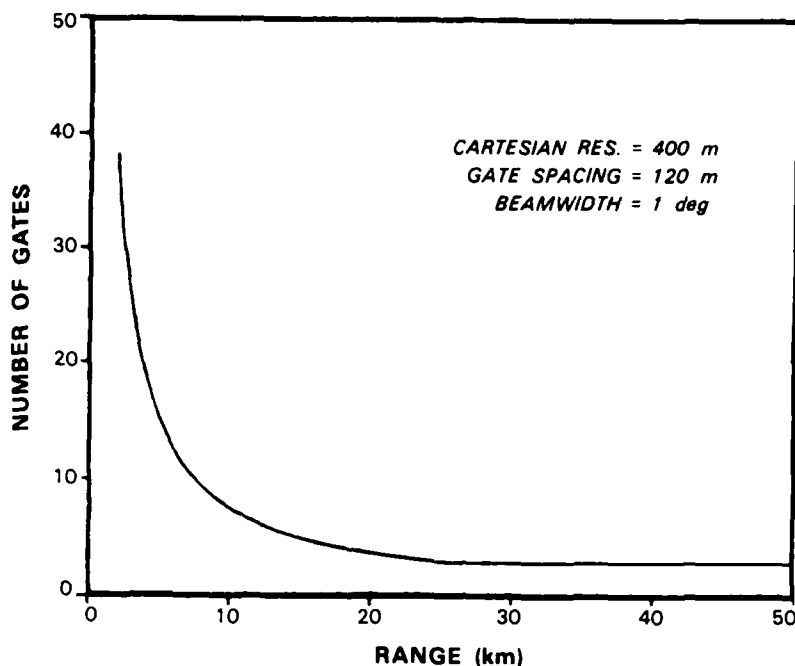

74888-13

Figure IV-5. Average number of gates per Cartesian square.

At a given range, there are N range samples per Cartesian square. The improvement due to a CMF is the difference between the minimum value of the N samples to the average of the N samples. This is the same as comparing the mean value of the distribution P with the mean of its first order statistic (or its expected lowest value).

We have used the Weibull Distribution function for the magnitude of the radar cross section density,

$$P(\sigma^{\circ}) = 1 - \exp(-\sigma^{\circ b}/\alpha) \quad (1)$$

with mean,

$$\bar{\sigma}^{\circ} = \alpha^a \Gamma(1 + a) \quad (2)$$

as the cumulative distribution function (CDF) $P(\cdot)$ for several reasons. First, many groups at Lincoln Laboratory feel that this is a reasonable CDF to use for low depression angle clutter. Second, it is versatile; this CDF forms a straight line on a Rayleigh probability scale with slope,

$$a = 1/b \quad , \quad (3)$$

which approximates the measured data well. Finally, the Weibull CDF is one of the few CDFs that have convenient asymptotic order statistics.

It can be shown that the first order statistics of a Weibull CDF with n samples are,

$$F_1(\sigma^\circ) = 1 - \exp -\sigma^\circ b / \frac{\alpha}{n} \quad (4)$$

with mean of,

$$\sigma^\circ = n^{-a} \bar{\sigma}^\circ \quad (5)$$

Equation (4) indicates that the shape of the minimum distribution is the same as the shape of the prefiltered distribution. In other words, the characteristics of the clutter are not altered. The mean of the curve is reduced by a function of n as in Equation (5).

This analysis is centered around the fact that there are N range samples to chose from in a Cartesian bin. The number N is a function of range, however,

$$N = \frac{\Delta X^2}{r_g r \theta} \quad (6)$$

Furthermore, the equivalent reflectivity factor of clutter is also a function of range:

$$I = K \sigma / r \quad (7)$$

To highlight the improvement due to a CMF, we have combined all range dependencies into one graph.

Figure IV-6 summarizes the effect of a CMF on signal-to-clutter ratio. The signal-to-clutter ratio (SCR) for 0 dBz weather signal and a mean clutter radar cross section density of -40 dB is displayed with representative clutter slopes, a. We find a large initial clutter reduction at close range. At longer range, the reduction in effective clutter level due to the range advantage of weather (Equation 6) is not large enough to offset the loss in CMF improvement from fewer range gates/Cartesian cell.

As the variance of the clutter increases, the CMF becomes more effective. This is due to the fact that clutter patches with high variances typically have a high terrain (or building) relief in which large clutter sources shadow the clutter from cells at greater ranges.

Figure IV-6 suggests that for a -40 dB mean clutter cross section with a Weibull slope of 2, the SCR for a 0 dBz weather target should be increased by 20 dB to at least -40 dB SCR everywhere within 10 km of the radar. The use of a high pass time series filter (such as the test-bed FIR filter) to suppress the clutter by some 50 dB in cascade with the CMF to reduce the clutter residue would increase the SCR to +10 dB for the postulated clutter environment. This level of clutter rejection should enable us to detect accurately and estimate 0 dBz low-level weather events within 10 km of the radar. Simulations of a CMF will be performed in the next quarter.

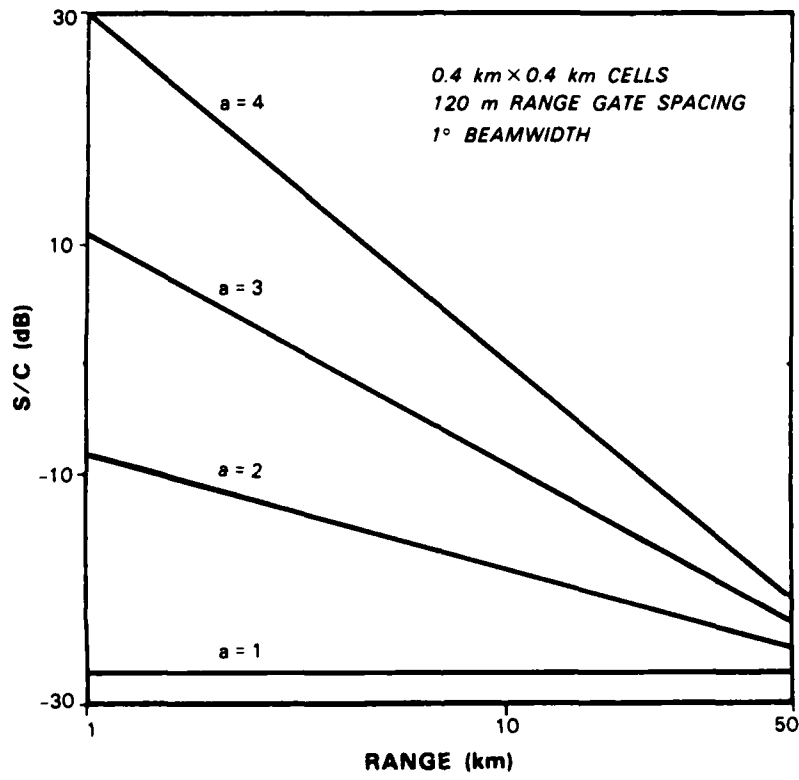

74888-14

Figure IV-6. SCR vs range after CMAP filter for 0 dBz signal, radar-cross-section density, and representative Weibull slopes.

V. USE OF WEATHER RADAR DATA WITHIN THE CENTRAL WEATHER PROCESSOR (CWP)

A. FEDERAL METEOROLOGICAL HANDBOOK SUPPORT

A new volume of the Federal Meteorological Handbook, designated as FMH-11, is being prepared to serve as the operational handbook for the NEXRAD System. The task of writing this document has been delegated to five Working Groups, each of which has responsibility for certain portions of FMH-11 and is comprised of representatives from DoT, DoC, DoD, the IOTF, and technical advisors from institutions such as Lincoln Laboratory. A representative from Lincoln Laboratory is serving on Working Group E (WGE), which has been tasked to write the sections of FMH-11 specifying operational modes, scanning strategies, product mixes, product shedding priorities and mode selection/deselection criteria.

The second meeting of WGE was held in mid-July in Olive Branch, Mississippi. Lincoln Laboratory served as coordinator for this meeting and provided a site tour of the FL-2 radar for the attendees — IOTF: J. Fornear and D. Forsythe; AWS: C. Bjerkaas; NWS: P. Ahnert; MITRE: F. Amodeo; and LL: M. Goldberg.

The meeting consisted primarily of discussions of the feasibility of the proposed WGE scanning strategies within the NEXRAD context. Analyses prepared by WGE members regarding scanning strategy interactions with Doppler estimates, RDA data rates, RPG computational requirements, RPG storage requirements and meteorological surveillance requirements were presented. It was decided that the WGE proposals essentially were consistent with the NEXRAD Technical Requirements (NTR) and that they also were likely to be consistent with contractor-specific implementation details to which WGE was not privy. Some changes, primarily of an editorial nature, were made to the WGE document in preparation for the November FMH-11 meeting.

In order to maintain consistency between the NTR and the FMH-11, WGE submitted an appropriately modified version of its FMH-11 document to the user agencies as a revised version of Appendix I for the Limited Production Phase NTR. (Appendix I is the portion of the NTR that details scanning strategies and mode selection/deselection criteria.)

B. CWP PROGRAM OFFICE SUPPORT

Lincoln personnel participated in the Jet Propulsion Laboratory system review in Pasadena, California, 29 July-3 August, as well as in several Radar Working Group (RWG) meetings. The principal focus in the radar processing area at these meetings was processing of the current Radar Remote Weather Display System (RRWDS) reflectivity data, with particular emphasis on clutter mitigation. Clutter contamination is particularly troublesome for FAA use of RRWDS since the current NWS radars do not have any MTI filtering and often have significant clutter contamination in the vicinity of an airport.

VI. SPECIFICATION OF NEXRAD PRODUCTS FOR USE IN THE CENTRAL WEATHER PROCESSOR

During the third quarter of 1985, reflectivity tracking and extrapolation studies were concentrated upon the implementation and evaluation of a first-cut algorithm for producing the NEXRAD Storm Extrapolation Map (SEM) product. A report was written, detailing the performance and computational requirements of this algorithm, and was distributed to the NEXRAD Joint System Program Office (JSPO) and to the FAA's Weather Processors Office. In addition, the JSPO was provided with both a product description and a functional specification for the SEM.

The Lincoln SEM algorithm produces extrapolated maps of thresholded reflectivity regions on the basis of tracking information from either the STORM POSITION FORECAST [008] or CROSS-CORRELATION TRACKING [034] algorithms, as dictated by the prevailing meteorology, and an extrapolation time interval supplied by the user. The SEM produces its maps by combining the following four operations:

- (1) Storm Identification, in which an input Cartesian reflectivity field is segmented into contiguous regions of reflectivity above a specified threshold (e.g., 30 dBz);
- (2) Centroid to Storm Association, in which volumetric, mass weighted centroids from the STORM CENTROIDS [005] algorithm are associated with the regions identified in (1);
- (3) Velocity to Centroid Association, in which tracking information from the selected tracker is associated with the centroids/storms identified in (2); and
- (4) Storm Displacement, in which an extrapolated map is created by advecting the velocity-tagged storms identified in (3) for the user-specified extrapolation time interval.

For an arbitrary number of extrapolations from a given time, steps 1-3 need only be performed once; step 4 is performed for each extrapolation. With the NEXRAD LAYER COMPOSITE REFLECTIVITY product as the Cartesian input field and three extrapolation intervals (10, 20, and 30 min), total running times, excluding I/O operations, are on the order of 0.6 seconds.

During the course of the performance evaluations, it became apparent that the 4-km resolution of the LAYER COMPOSITE product was too coarse to support a functional extrapolation capability over the time scales of interest. As the translation of reflectivity pixels must occur in integral multiples of the Cartesian resolution, the LAYER COMPOSITE product only provides for a 2-km positioning accuracy in either dimension, for a maximum possible error of 2.8 km relative to the tracking information. Earlier evaluations conducted at Lincoln with analogous algorithms have indicated that a functional extrapolation capability may be obtained with resolutions on the order of 1 to 2 km. Current studies therefore are focusing on techniques that either will ingest higher resolution reflectivity data (e.g., COMPOSITE REFLECTIVITY with 1-km resolution) or oversample the current 4-km data, while retaining the displayed resolution of the product at 4 km.

The NEXRAD Process Definition Language (PDL) description of the Binary Correlation Tracker (BCT) algorithm was validated by PROFS in September for functionality. A meteorological assessment of that algorithm is scheduled at PROFS for the beginning of 1986. The SASC documentation for the BCT is essentially complete.

Professor Robert Crane of Dartmouth University presented some preliminary results from the growth and decay study subcontracted to him by Lincoln.

All active tracking and extrapolation software at Lincoln has been converted to the I/O standards of the project's Cartesian format (CAR). This will allow the tracking and prediction effort to make use of the general utilities and support provided for CAR.

Arbitrary Vertical Cross Section Product. During this quarter, most of the work on the Arbitrary Vertical Cross Section (AVX) product was focused on developing a functional specification and a working program. This product allows the user to view the storm features (e.g., reflectivity, radial velocity, or spectrum width) along a user specified vertical cut. This product was suggested by CWSU meteorologists at the Boston ARTCC as being of particular use in squall line situations. Such squall lines are a significant problem for air traffic control because the aircraft cannot easily fly around the phenomena. The NEXRAD JSPO decided to define this product with a functional specification. Therefore, we have not developed PDL for the AVX product.

While constructing a functional specification of the AVX product, a number of issues arose. First the method of interpolating between noncontiguous beams was considered. A few possible methods are linear averaging vertically, horizontally, or between nearest neighbors. The best interpolation method may be a function of the weather phenomena. With vertically homogeneous weather, a vertical interpolation would yield the best results. However, horizontally homogeneous weather would require horizontal interpolation.

Second, the horizontal extent of the width of the AVX was considered. This also may be a function of the weather. A thin width may be tolerated when looking at gust fronts; however, a wider width may be needed when looking at a line of storm cells. The best solution to these problems will be obtained through practice. In the future, we will be looking at these issues by using a data analysis version of the AVX product.

A version of the AVX product generation algorithm that uses polar radar data was designed and implemented to yield an AVX data analysis product. It has been used with some of the data that has been collected and translated from the test site in Olive Branch, Mississippi. The interpolation option has not yet been built into the program. During the next quarter, we will work on developing this product into a more general data analysis utility. This will include making the program more user friendly and developing more user options.

It has been determined that the main time consuming sections of the code are the beam filling section and the I/O section. When converting the polar radar data to Cartesian form, holes appear between contiguous beams. Beam filling accounts for the finite width of the radar beam and eliminates these artifacts.

In the future, we will work on optimizing our algorithm. This will include considering alternative methods in storing and retrieving the large amount of data recorded during a single volume scan. We also will work on optimizing the critical loop in the beam filling section. This may include restructuring the algorithm in this section.

REFERENCES

1. Weather Radar Studies Quarterly Technical Summary, Lincoln Laboratory, MIT (30 June 1985).
2. M. Labitt, "Coordinated Radar and Aircraft Observations of Turbulence," Project Report ATC-108, Lincoln Laboratory, MIT (1981), FAA-RD-81-44.
3. A.R. Bohne, "Radar Detection of Turbulence in Precipitation Environments," J. Atmos. Sci. **39**, 1819-1837 (1982).
4. A.R. Bohne, "Radar Detection of Turbulence in Thunderstorms," Air Force Geophysics Laboratory Report, AFGL-TR-81-0102 (March 1981).
5. W. Lewis, R.G. Oliver, A. DelaMarche, and T.Y. Lee "Test and Evaluation of the Radar Thunderstorm Turbulence Detection System (Phase I)," FAA Technical Center Report DOT/FAA/RD-82/22 (July 1982).
6. P. MacCready, "Standardization of Gustiness from Aircraft," J. of Appl. Meteorol. **3**, 439-449 (1964).

PRINCIPAL CONTRIBUTORS

The principal contributors to this report were M.M. Wolfson, M.W. Merritt, W.H. Drury, M.H. Goldberg, J.T. DiStefano, A.F. Dockrey, L. Henshaw, F.X. Groezinger, Jr., T.H. Einstein, D.M. Bernella, R.E. Rinehart, D.R. Mann, and M.E. Weber.

GLOSSARY

A/D	Analog-to-Digital (signal conversion)
AGC	Automatic Gain Control
ALU	Arithmetic Logic Unit
APU	Arithmetic Processing Unit
ARTCC	Air Route Traffic Control Center
AVX	Arbitrary Vertical Cross Section
AWS	Air Weather Service
BCT	Binary Correlation Tracker
BPD	Base Products Display
CAR	Cartesian Format
CDF	Cumulative Distribution Function
CFT	Common Radar Format Data Tape
CIDF	Lincoln Laboratory Common Instrument Data Format
CLAWS	Classify, Locate, and Avoid Wind Shear
CMAP	Clutter Map
CMF	Clutter Map Filter
COHMEX	Cooperative Huntsville Meterological Experiment
COHO	Coherent Oscillator
CWP	Central Weather Processor
CWSU	Central Weather Service Unit
DAA	Data Acquisition and Analysis (Processor)
dBz	Unit of Weather Reflectivity
DCP	Data Collection Platform (implies transmitter to GOES satellite)
DMA	Direct Memory Access
FAA	Federal Aviation Administration
FIFO	First In, First Out (data buffer)
FIR	Finite Impulse Response
FLWS	FAA/Lincoln Laboratory Operational Weather Studies
FL-2	FAA/Lincoln Laboratory Test-Bed Doppler Radar
FTP	File-Transfer Protocol
GOES	Geostationary Operational Experimental Satellite
INS	Inertial Navigation System
IOTF	Interim Operational Test Facility
JAWS	Joint Airport Weather Studies
JSPO	Joint System Program Office (for NEXRAD program)

LAWS	Low-Altitude Wind Shear
LLWSAS	Low-Level Wind-Shear Alert System
MB	Megabyte
Mesonet	Refers to a network of automatic weather stations with a close, i.e., a 'mesoscale' spacing. Lincoln's spacing might be called 'microscale.'
MIST	Microburst and Severe Thunderstorm Project
MPM	Multiport Memory
MTI	Moving Target Indicator
NASA	National Aeronautics and Space Administration
NCAR	National Center for Atmospheric Research, Boulder, Colorado
NEXRAD	Next Generation Weather Radar
NSSL	National Severe Storms Laboratory, Norman, Oklahoma
NTR	NEXRAD Technical Requirements
NWS	National Weather Service
PDL	Process Definition Language
PE	Processing Element
P.E.	Perkin-Elmer
PID	Pulse Interference Detector
PPI	Planned Position Indicator
PRF	Pulse Repetition Frequency
PROFS	Prototype Regional Observing and Forecasting System
RDA	Radar Data Acquisition
RHI	Range Height Indicator
RPG	Radar Data Acquisition
RRWDS	Radar Remote Weather Display System
RTCP	Real-Time Control Program
RWG	Radar Working Group
SASC	Systems and Applied Sciences Corporation
SCR	Signal-to-Clutter Ratio
SEM	Storm Extrapolation Map
SGP	Single Gate Processing
SP	Signal Processor
SPACE	Satellite, Precipitation, and Cloud Experiment
TBS	Trackball Server
TCP/IP	Transmission Control Protocol/Internet Protocol
TDR	Terminal Doppler Weather Radar

UND
UNIX
WGE

University of North Dakota
'Generic' operating system developed by Bell Laboratories
Working Group E

