

AD-A169 562

IN-LINE AND TRANSVERSE FORCES ON SMOOTH AND ROUGH  
CYLINDERS IN OSCILLATOR. (U) NAVAL POSTGRADUATE SCHOOL  
MONTEREY CA T SARPKAYA 04 JUL 86 MPS69-86-003

1/2

UNCLASSIFIED

NSF-CEE-8210264

F/G 20/4

NL

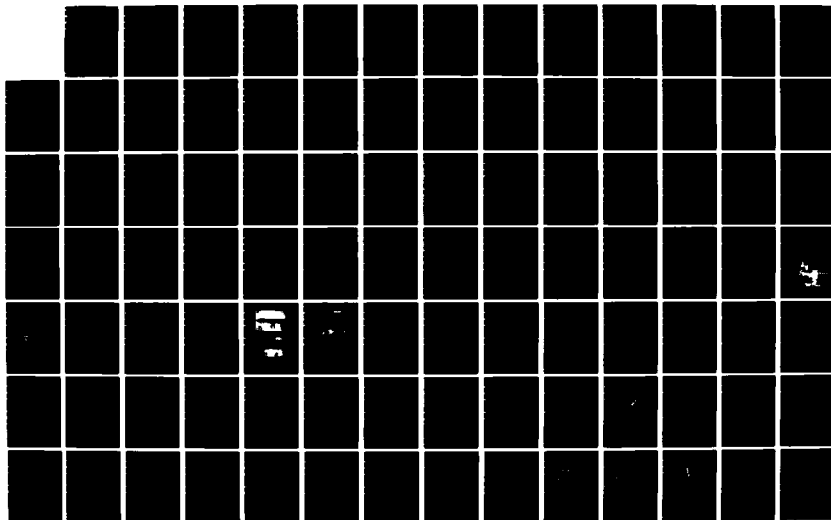

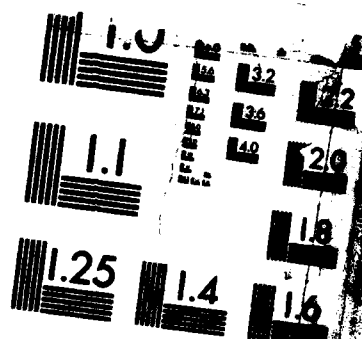

MICROCOPY RESOLUTION TEST CHART  
NATIONAL BUREAU OF STANDARDS-1963-A

2

NPS69-86-003

# NAVAL POSTGRADUATE SCHOOL

## Monterey, California

AD-A169 562



IN-LINE AND TRANSVERSE FORCES ON  
SMOOTH AND ROUGH CYLINDERS IN  
OSCILLATORY FLOW AT HIGH REYNOLDS NUMBERS

TURGUT SARP KAYA

4 JULY 1986

INTERIM REPORT FOR PERIOD JULY 1985 - JULY 1986

OTIC FILE COPY

APPROVED FOR PUBLIC RELEASE; DISTRIBUTION UNLIMITED.

PREPARED FOR:

NATIONAL SCIENCE FOUNDATION  
WASHINGTON, D. C. 20550

86 7 14 019

**NAVAL POSTGRADUATE SCHOOL**  
Monterey, California

Rear Admiral R. H. Shumaker  
Superintendent

D. A. Schrady  
Provost

The work reported herein was supported by the National Science Foundation through Grant No. CEE-8210248.

Reproduction of all or part of this report is authorized.

This report was prepared by:



**TURGUT SARPKAYA**  
Distinguished Professor of  
Mechanical Engineering

Reviewed by:

Released by:



Paul J. Marto, Chairman  
Department of Mechanical  
Engineering



John N. Dyer, Dean of  
Science and Engineering

UNCLASSIFIED

SECURITY CLASSIFICATION OF THIS PAGE

A169562

## REPORT DOCUMENTATION PAGE

1a REPORT SECURITY CLASSIFICATION UNCLASSIFIED		1b RESTRICTIVE MARKINGS	
SECURITY CLASSIFICATION AUTHORITY		3 DISTRIBUTION / AVAILABILITY OF REPORT Approved for public release; distribution unlimited.	
2b DECLASSIFICATION / DOWNGRADING SCHEDULE		5 MONITORING ORGANIZATION REPORT NUMBER(S)	
4 PERFORMING ORGANIZATION REPORT NUMBER(S) NPS69-86-003		7a NAME OF MONITORING ORGANIZATION NATIONAL SCIENCE FOUNDATION	
6a NAME OF PERFORMING ORGANIZATION Naval Postgraduate School	6b OFFICE SYMBOL (if applicable) 69SL	7b ADDRESS (City, State, and ZIP Code) Washington, D. C. 20550	
6c ADDRESS (City, State, and ZIP Code) Monterey, California 93943-5000		9 PROCUREMENT INSTRUMENT IDENTIFICATION NUMBER CEE-8210264	
8a NAME OF FUNDING / SPONSORING ORGANIZATION NATIONAL SCIENCE FOUNDATION	8b OFFICE SYMBOL (if applicable)	10 SOURCE OF FUNDING NUMBERS	
8c ADDRESS (City, State, and ZIP Code) 1800 G. Street Washington, D. C. 20550		PROGRAM ELEMENT NO	PROJECT NO
11 TITLE (Include Security Classification) IN-LINE AND TRANSVERSE FORCES ON SMOOTH AND ROUGH CYLINDERS IN OSCILLATORY FLOW AT HIGH REYNOLDS NUMBERS		TASK NO	WORK UNIT ACCESSION NO
12 PERSONAL AUTHOR(S) TURGUT SARP KAYA			
TYPE OF REPORT Interim	13b TIME COVERED FROM 7/85 TO 7/86	14 DATE OF REPORT (Year, Month, Day) 1986 July 4	15 PAGE COUNT 173
16 SUPPLEMENTARY NOTATION			
17 COSATI CODES		18 SUBJECT TERMS (Continue on reverse if necessary and identify by block number)	
FIELD	GROUP	Oscillating flow, Wave forces, Drag and inertia, Unsteady flow, Time-dependent flow	
19 ABSTRACT (Continue on reverse if necessary and identify by block number) This report presents the results of an extensive experimental investigation of the in-line and transverse forces acting on smooth, sand-roughened, and marine-roughened circular cylinders ( $k/D = 1/50$ ) of identical length-to-diameter ratio ( $L/D = 2$ ) placed in a sinusoidally oscillating flow. The drag, inertia, and the maximum force coefficients have been determined through the use of the Fourier analysis. The transverse force (lift) has been analysed in terms of its root-mean-square value. In addition, the amplitude of the first ten harmonics have been determined. The results are presented in both graphical and tabulated form in terms of the Reynolds number, Keulegan-Carpenter number, relative roughness and the frequency parameter $\beta (= Re/K)$ .			
20 DISTRIBUTION / AVAILABILITY OF ABSTRACT <input checked="" type="checkbox"/> UNCLASSIFIED UNLIMITED <input type="checkbox"/> SAME AS RPT <input type="checkbox"/> DTIC USERS		21 ABSTRACT SECURITY CLASSIFICATION UNCLASSIFIED	
NAME OF RESPONSIBLE INDIVIDUAL Prof. Turgut Sarpkaya		22b TELEPHONE (Include Area Code) (408) 646-3425	22c OFFICE SYMBOL Code 69SL

DD FORM 1473, 84 MAR

83 APR edition may be used until exhausted  
All other editions are obsolete

SECURITY CLASSIFICATION OF THIS PAGE

UNCLASSIFIED

## SUMMARY

This report presents the results of an extensive experimental investigation of the in-line and transverse forces acting on smooth, sand-roughened, and marine-roughened circular cylinders ( $k/D = 1/50$ ) of identical length-to-diameter ratio ( $L/D = 2$ ) placed in a sinusoidally oscillating flow. The drag, inertia, and the maximum force coefficients have been determined through the use of the Fourier analysis. The transverse force (lift) has been analysed in terms of its root-mean-square value. In addition, the amplitude of the first ten harmonics have been determined.

The results have shown that:

1. The smooth-cylinder data presented herein agree quite well with those presented by Sarpkaya [1,2] in 1976 and by Rodenbusch and Gutierrez [7] in 1983;

2. Bearman et al.'s [11] drag coefficients are somewhat lower in the range of comparison (i.e., for  $K < 20$ ) than those of Rodenbusch and Gutierrez [7];

3. The drag, inertia, and the maximum force coefficients for smooth cylinders are at best a very weak function of the Reynolds number ( $Re$ ) for  $Re$  larger than about 100,000;

4. The rms value of the lift coefficient for smooth cylinders reaches a peak value of about 1.6. For Keulegan-Carpenter numbers ( $K$ ) larger than about 13, the dependence of  $C_{Lrms}$  on  $\beta (= Re/K)$  decreases rapidly with increasing  $\beta$ ;

5. The analysis of the amplitude of the first ten harmonics of the lift force for smooth cylinders has shown that all harmonics are present, to varying degrees of importance, in the lift force. However, the second and fourth harmonics dominate the drag-inertia dominated regime. The amplitude of all harmonics, with the exception of the second and the fourth, decreases rapidly with increasing  $\beta$ ;

6. For rough cylinders ( $k/D = 1/50$ ), the drag and inertia coefficients become independent of  $\beta$  or of the Reynolds number for  $\beta$  larger than about 4000;

7. The drag coefficient exhibits pronounced secondary peaks in the neighborhood of  $K = 17, 24, \text{ and } 32$ . These are directly related to the harmonics of the lift force;

8. The rough-cylinder data presented herein agree quite well with those reported by Sarpkaya [2] in 1976 and show that the effect of roughness, particularly on the drag coefficient, is indeed very profound. The rough-cylinder drag-coefficient

data of Rodenbusch and Gutierrez [7] are somewhat lower than those obtained in the present investigation. Their inertia coefficients for  $K > 12$  are somewhat larger. The reasons for these differences are not clear. However, the facts, presented herein show that they are not attributable either to the differences in  $\beta$  or to the blockage effects in the U-tunnel;

9. The maximum force coefficient does not depend on either the relative roughness or  $\beta$  for  $K < 7$ ;

10. The rms value of the lift coefficient reaches a peak value of about 1.8 and is practically independent of  $\beta$ . The secondary oscillations in the rms value of the lift coefficient occur at  $K \approx 17, 24, 32, \text{ and } 41$ . These are the same  $K$  values at which similar oscillations with relatively smaller amplitudes occur in the drag coefficient;

11. The analysis of the harmonics of the lift force for rough cylinders shows that all harmonics, with the exception of the second, are of the same order of magnitude. In the drag-inertia dominated regime, primarily the second harmonic and to a lesser but equal extent the first, third, and fourth harmonics dominate the lift. The third and fifth harmonics in the neighborhood of  $K = 17$ ; the fourth, sixth, and eighth harmonics in the vicinity of  $K = 24$ ; and the fifth and seventh harmonics in the neighborhood of  $K = 32$  dominate the lift force.

12. The use of relatively short test cylinders with identical length-to-diameter ratio ( $L/D = 2$ ) brought into sharper focus the variation of all force coefficients and effectively removed the ambiguities associated with the use of test cylinders with different  $L/D$  ratios.

### ACKNOWLEDGEMENTS

The work described in this report represents part of a research program supported by the **National Science Foundation** under Agreement No. CEE-8210246. This support is gratefully acknowledged.

A special note of thanks is extended to Mr Jack Mc Kay for his most skilful and dedicated work in the design, construction and smooth operation of the test facilities.



Accession For	
NTIS GR831	A
NTIS T	
Un	
By	
Distrib	
Avail	
Dist	
A-1	

## TABLE OF CONTENTS

I.	INTRODUCTION - - - - -	11
II.	OSCILLATING FLOW SYSTEM - - - - -	17
	A. U-SHAPED WATER TUNNEL AND ITS EVOLUTION - - -	17
	B. FORCE MEASUREMENTS - - - - -	21
	C. ACCELERATION, ELEVATION, AND VELOCITY MEASUREMENTS - - - - -	23
	D. DATA ACQUISITION SYSTEM - - - - -	24
	E. CIRCULAR CYLINDERS - - - - -	24
III.	FORCE COEFFICIENTS AND GOVERNING PARAMETERS - - -	27
	A. IN-LINE FORCE - - - - -	27
	B. TRANSVERSE FORCE - - - - -	28
	C. REMARKS REGARDING THE DATA - - - - -	29
IV.	PRESENTATION AND DISCUSSION OF THE RESULTS - - -	30
	A. REMARKS - - - - -	30
	B. SMOOTH CYLINDER DATA - - - - -	30
	C. ROUGH CYLINDER DATA - - - - -	37
	V. CONCLUSIONS - - - - -	44
	REFERENCES - - - - -	47
	FIGURES - - - - -	50-106
APPENDIX A:	IN-LINE FORCE COEFFICIENTS FOR SMOOTH CYLINDERS ( $k/D = 0$ ),      BETA =	
	= 2300 - - -	107
	= 3435 - - -	109
	= 4720 - - -	112
	= 6555 - - -	115
	= 11,525 - - -	117

APPENDIX B:	RMS VALUE OF THE LIFT FORCE FOR SMOOTH		
	CYLINDERS ( $k/D = 0$ ),	BETA =	2300 - - - 119
		=	3435 - - - 120
		=	4720 - - - 122
		=	6555 - - - 123
APPENDIX C:	HARMONICS OF THE LIFT FORCE FOR SMOOTH		
	CYLINDERS ( $k/D = 0$ ),	BETA =	2300 - - - 124
		=	3435 - - - 126
		=	4720 - - - 130
		=	6555 - - - 132
APPENDIX D:	IN-LINE FORCE COEFFICIENTS FOR ROUGH		
	CYLINDERS ( $k/D = 1/50$ ),	BETA =	2412 - - - 134
		=	3598 - - - 137
		=	4924 - - - 140
		=	6836 - - - 143
		=	9354 - - - 145
		=	14,200 - - - 146
	IN-LINE FORCE COEFFICIENTS FOR		
	MARINE-ROUGHENED CYLINDERS ( $k/D = 1/50$ )		
	POSITION A:	BETA =	8100 - - - 147
		=	10,964 - - - 147
		=	13,724 - - - 148
		=	13,890 - - - 148
	POSITION B:	=	13,122 - - - 149
		=	13,517 - - - 149
APPENDIX E:	RMS VALUE OF THE LIFT FORCE FOR ROUGH		
	CYLINDERS ( $k/D = 1/50$ ),	BETA =	2412 - - - 150
		=	3598 - - - 151
		=	4924 - - - 152
		=	6836 - - - 153
APPENDIX F:	HARMONICS OF THE LIFT FORCE FOR ROUGH		
	CYLINDERS ( $k/D = 1/50$ ),	BETA =	2412 - - - 154
		=	3598 - - - 158
		=	4924 - - - 162
		=	6836 - - - 164
INITIAL DISTRIBUTION LIST	- - - - -	- - - - -	166

## LIST OF FIGURES

1.	A sketch of the exterior of the water tunnel - - - - -	50
2a.	Cross-section of the U-shaped water tunnel - - - - -	51
2b.	A photograph of the U-shaped water tunnel - - - - -	51
3.	Air supply system - - - - -	52
4.	Details of the three-way valve - - - - -	53
5.	Force transducer and its housing - - - - -	54
6a.	Three-piece test cylinder - - - - -	55
6b.	Three-piece smooth and rough cylinders - - - - -	56
7.	Marine-roughened cylinder - - - - -	57
8.	Sample in-line force trace, $K = 9.23$ , $k/D = 0$ , $\beta = 11,525$ -	58
9.	Sample in-line force trace, $K = 9.79$ , $k/D = 0$ , $\beta = 4720$ -	59
10.	Sample in-line force trace, $K = 11.51$ , $k/D = 0.02$ , $\beta = 6836$	60
11.	Sample in-line force trace, $K = 15.81$ , $k/D = 0$ , $\beta = 11,525$ -	61
12.	Sample transverse force trace, $K=14.74$ , $k/D=0.02$ , $\beta = 4924$ -	62
13.	Sample transverse force trace, $K=17.48$ , $k/D = 0$ , $\beta = 3435$ -	63
14.	Sample transverse force trace, $K=17.62$ , $k/D=0.02$ , $\beta = 4924$ -	64
15.	Sample transverse force trace, $K=24.12$ , $k/D=0.02$ , $\beta = 4924$ -	65
16.	Drag and inertia coefficients for a smooth cylinder as a function of $K$ , $\beta = 2300$ - - - - -	66
17.	Drag and inertia coefficients for a smooth cylinder as a function of $K$ , $\beta = 3435$ - - - - -	67
18.	Drag and inertia coefficients for a smooth cylinder as a function of $K$ , $\beta = 4720$ - - - - -	68
19.	Drag and inertia coefficients for a smooth cylinder as a function of $K$ , $\beta = 6555$ - - - - -	69
20.	Drag and inertia coefficients for a smooth cylinder as a function of $K$ , $\beta = 11525$ - - - - -	70

21.	Drag coefficient for two smooth cylinders as a function of K, o, $\beta = 6555$ ; +, $\beta = 11525$ - - - - -	71
22.	Inertia coefficient for two smooth cylinders as a function of K, *, $\beta = 6555$ ; x, $\beta = 11525$ - - - - -	72
23.	Comparison of the present data with those reported in 1976 [1,2] for K = 20, o and *: present data; ● and +: 1976 data - - - - -	73
24.	Comparison of the present drag coefficients with those obtained by Sarpkaya [1,2], Rodenbusch & Gutierrez [7], and Bearman et al. [11] - - - - -	74
25.	Comparison of the present inertia coefficients with those obtained by Sarpkaya [1,2], Rodenbusch & Gutierrez [7], and Bearman et al. [11] - - - - -	75
26.	Maximum force coefficient for smooth cylinders as a function of K, o, $\beta = 2300$ ; x, $\beta = 3435$ ; #, $\beta = 4720$ ; *, $\beta = 6555$ ; +, $\beta = 11525$ - - - - -	76
27.	RMS lift coefficient for smooth cylinders as a function of K, o, $\beta = 2300$ ; x, $\beta = 3435$ ; #, $\beta = 4720$ ; and *, $\beta = 6555$ - - - -	77
28.	Amplitude of the harmonics of the lift force for a smooth cylinder, $\beta = 2300$ - - - - -	78
29.	Amplitude of the harmonics of the lift force for a smooth cylinder, $\beta = 3435$ - - - - -	79
30.	Amplitude of the harmonics of the lift force for a smooth cylinder, $\beta = 4720$ - - - - -	80
31.	Amplitude of the harmonics of the lift force for a smooth cylinder, $\beta = 6555$ - - - - -	81
32.	Drag and inertia coefficients for a rough cylinder as a function of K, $\beta = 2412$ , $k/D = 1/50$ - - - - -	82
33.	Drag and inertia coefficients for a rough cylinder as a function of K, $\beta = 3598$ , $k/D = 1/50$ - - - - -	83
34.	Drag and inertia coefficients for a rough cylinder as a function of K, $\beta = 4924$ , $k/D = 1/50$ - - - - -	84
35.	Drag and inertia coefficients for a rough cylinder as a function of K, $\beta = 6836$ , $k/D = 1/50$ - - - - -	85
36.	Drag and inertia coefficients for a rough cylinder as a function of k, $\beta = 9354$ , $k/D = 1/50$ - - - - -	86

37.	Drag and inertia coefficients for a rough cylinder as a function of $K$ , $\beta = 14200$ , $k/D = 1/50$ - - - - -	87
38.	Drag and inertia coefficients for two rough cylinders as a function of $K$ , $o (C_d)$ and $* (C_m)$ for $\beta = 6836$ ; $+ (C_d)$ and $x (C_m)$ for $\beta = 14200$ - - - - -	88
39.	Comparison of drag and inertia coefficients for four rough cylinders, $o (C_d)$ , $* (C_m)$ for $\beta = 4924, 6836, 9354$ , and $14200$	89
40.	Comparison of drag coefficients for six rough cylinders, $*$ , $\beta = 2412$ ; $+$ , $\beta = 3598$ ; $\#$ , $\beta = 4924$ ; $\phi$ , $\beta = 6836$ ; $o$ , $\beta = 9354$ ; $x$ , $\beta = 14200$ - - - - -	90
41.	Comparison of inertia coefficients for six rough cylinders, $*$ , $\beta = 2412$ ; $+$ , $\beta = 3598$ ; $\#$ , $\beta = 4924$ ; $\phi$ , $\beta = 6836$ ; $o$ , $\beta = 9354$ ; $x$ , $\beta = 14200$ - - - - -	91
42.	$C_d$ versus $Re$ for $K = 20$ (from [2]); $\bullet$ , present data for $k/D = 1/50$ - - - - -	92
43.	$C_d$ versus $Re$ for $K = 30$ (from [2]); $\bullet$ , present data for $k/D = 1/50$ - - - - -	92
44.	Drag coefficient for the marine-roughened cylinder (position A), $o$ , $\beta = 8100$ ; $x$ , $\beta = 10964$ ; $\#$ , $\beta = 13724$ ; $*$ , $\beta = 13890$ - - - - -	93
45.	Inertia coefficient for the marine-roughened cylinder (position A), $o$ , $\beta = 8100$ ; $x$ , $\beta = 10964$ ; $\#$ , $\beta = 13724$ ; $*$ , $\beta = 13890$ - - - - -	94
46.	Drag coefficient for the marine-roughened cylinder (position B), $o$ , $\beta = 13122$ ; $+$ , $\beta = 13517$ - - - - -	95
47.	Inertia coefficient for the marine-roughened cylinder (position B), $o$ , $\beta = 13122$ ; $+$ , $\beta = 13517$ - - - - -	96
48.	Comparison of the present drag coefficient data with those obtained by Rodenbusch and Gutierrez [7]. Sand-roughened cylinders: $o$ , $\beta = 9354$ and $14200$ ; marine-roughened cylinders: $x$ , $\beta = 13122$ and $13517$ ; Rodenbusch & Gutierrez: $\#$ , $\beta = 7000$ to $140,000$ - - - - -	97
49.	Comparison of the present inertia coefficient data with those obtained by Rodenbusch and Gutierrez [7]. Sand-roughened cylinders: $o$ , $\beta = 9354$ and $14200$ ; marine-roughened cylinders: $x$ , $\beta = 13122$ and $13517$ ; Rodenbusch & Gutierrez: $\#$ , $\beta = 7000$ to $140,000$ - - - - -	98

50.	Maximum force coefficient for rough cylinders as a function of K, o, $\beta = 2412$ ; x, $\beta = 3598$ ; # $\beta = 4924$ ; +, $\beta = 6836$ ; *, $\beta = 9354$ ; $\phi$ , $\beta = 14200$ - - - - -	99
51.	Maximum force coefficient for a smooth and sand-roughened cylinder, smooth cylinder: x, $\beta = 11525$ ; rough cylinder: o, $\beta = 14200$ - - - - -	100
52.	RMS lift coefficient for rough cylinders as a function of K, o, $\beta = 2412$ ; x, $\beta = 3598$ ; #, $\beta = 4924$ ; and *, $\beta = 6836$ - - - -	101
53.	RMS lift coefficient for a smooth and sand-roughened cylinder, smooth cylinder: o, $\beta = 6555$ ; rough cylinder: *, $\beta = 6836$ - -	102
54.	Amplitude of the harmonics of the lift force for a rough cylinder, $\beta = 2412$ - - - - -	103
55.	Amplitude of the harmonics of the lift force for a rough cylinder, $\beta = 3598$ - - - - -	104
56.	Amplitude of the harmonics of the lift force for a rough cylinder, $\beta = 4924$ - - - - -	105
57.	Amplitude of the harmonics of the lift force for a rough cylinder, $\beta = 6836$ - - - - -	106

**LIST OF TABLES**

Table 1. Some Details of the Related Investigations - - 16

Table 2. Characteristics of the Test Cylinders - - - - 27

Table 3. Ideal Values of the Inertia Coefficient for  
Various Values of  $\beta$  for Smooth and Sand-  
Roughened Cylinders - - - - - 33

## I. INTRODUCTION

In 1976, Sarpkaya [1,2]<sup>†</sup> reported the results of a comprehensive series of experiments with a sinusoidally oscillating planar flow about smooth and rough cylinders and introduced the parameter  $\beta$  ( $= Re/K = D^2/\nu T$ ) into the analysis of separated time-dependent flows\*. His data and his re-analysis of the Keulegan-Carpenter data, through the use of  $\beta$ , demonstrated clearly the dependence of the force-transfer coefficients (lift, drag and inertia) on the Reynolds number, Keulegan-Carpenter number, and the relative roughness. During the past ten years, these data have stimulated a great deal of research activity and gave rise to a number of questions: Are these data applicable to the design of offshore structures; what is the effect of the orbital motion of the fluid particles; do the data apply to horizontal cylinders; why are the drag coefficients for rough cylinders so large; are there blockage effects; do the in-line and transverse forces vary significantly from cycle to cycle; what is the effect of the spanwise coherence; does Morison's equation hold true for all values of  $K$  ( $= 2\pi A/D = U_m T/D$ ), (first introduced by Schlichting [3] in 1932) and  $Re$  ( $= U_m D/\nu$ ); why is the added mass coefficient sometimes negative; what happens at very low  $K$  values, etc.? These

---

<sup>†</sup> A complete list of references is given on page 47.

\*  $\beta$  has been used previously in connection with the analysis of unseparated oscillating flows (see e.g., [3]).

questions were in general valid and required a great deal of additional research for their clarification and resolution (see Sarpkaya and Isaacson [4] for additional details).

A number of projects have been undertaken, both in the laboratory and the field, since 1976. A large scale experiment (Ocean Test Structure experiments, referred to hereafter as the OTS tests) was undertaken by Exxon Production Research Company to evaluate the then present (1979) wave force calculation procedures for fixed, space-frame structures [5]. The Reynolds numbers and Keulegan-Carpenter numbers encountered in the OTS tests were somewhat less than those used in extreme wave design. As with all field experiments, the environmental conditions (wave and current kinematics) could not be specified with great precision for the OTS tests so that some conditions of interest were not observed. The force coefficients exhibited large scatter particularly for  $K < 20$ . The scatter decreased considerably in the range  $20 < K < 45$ . The drag coefficients were significantly larger than those previously observed in the field, especially for barnacle-covered cylinders. Heideman, Olsen, and Johansson [5] attributed the scatter in the drag and inertia coefficients to random wake encounters with the current meters. They have concluded that Morison's equation with constant coefficients can be made to fit measured local forces and kinematics satisfactorily over individual half wave cycles and that most of the scatter in the drag coefficient can be explained by the random-wake-encounter concept. Another major

field investigation is that conducted at the Christchurch Bay (CB) by the National Maritime Institute of England. The wave force data obtained from the CB tower have been analyzed by Bishop [6] through the use of a mean-square method.

For the depth station nearest to the sea surface, Bishop found:  $C_m = 1.8$  and  $C_d = 0.66$  for  $K > 30$ , increasing  $C_d$  and  $C_m$  with decreasing  $K$  in the range  $5 < K < 30$ , and  $C_m = 2$  for  $K < 5$ . Bishop noted that  $C_d$  and  $C_m$  exhibited considerable variation in the range  $5 < K < 15$ . The reasons offered for this variation were: (i) even the shortest averaging period (40 seconds) was long enough to average out the variations of the force coefficients caused by vortex shedding and wake return, and (ii) the effect of the tidal current acting in conjunction with the vortex shedding in the mid  $K$  range. Bishop attributed the low variability of the force coefficients at high  $K$  values as a proof of the validity of a simple superposition of the current component to the wave particle velocity.

The CB tower study has demonstrated once again, like the great many other ocean-based experiments before it, that it is possible to obtain force coefficients which will be valuable for the design of structures but it would not be possible to isolate and interpret the significance of various major parameters on the force coefficients. Clearly, it is necessary to treat the two types of studies (laboratory and ocean) with respect to their ultimate objectives. The laboratory experiments are for the purpose of understanding the underlying

mechanisms, whereas the ocean experiments are utilitarian in character and the force coefficients derived from them reflect the combined effect of all the influences including the shortcomings of the speculative generalizations of the MOJS equation.

In 1983, Rodenbusch and Gutierrez [7] reported the results of a joint industry study, carried out in the Maritime Dynamics Laboratory of the Swedish Maritime Research Center (SSPA). A circular cylinder of 1 meter nominal diameter and 3 m long was subjected to various types of forced oscillations in a large basin. A circular plate 5 m in diameter was attached to the top of the test cylinder to promote two-dimensional flow about the cylinder by reducing the effect of the free-surface disturbances. The plate served this purpose quite well at low speeds. But "at speeds above 2 m/s, the flow over the top of the plate produced a drop in the water level near the trailing edge so that the water flowing out from under the plate produced a noticeable stern wave" [8,9]. Forces acting on the central 1 m section were used to deduce the force-transfer coefficients. For rough cylinder tests, the surface was covered uniformly with approximately 6000 roughness elements. The individual roughness elements were right conical frusta of 2 cm height ( $k/D = 0.02$ ) with 1.5 cm top diameter and 3 cm bottom diameter. The roughnesses were located on 4 cm centers in horizontal rows, with each row offset by 2 cm and separated by 3.5 cm. The cylinder diameter was assumed to be 1.04 m, i.e.,

$[D(\text{rough}) = D(\text{smooth}) + 2k]$  in the calculation of the force coefficients through the use of Morison's equation. The force coefficients obtained in the SSPA tests, with planar sinusoidal motion of the cylinder, were compared by Sarpkaya [10] with those obtained in a sinusoidally oscillating flow about smooth and rough cylinders [1,2]. Rodenbusch and Källström [8] and Rodenbusch [9] presented the data obtained in simulated random two-dimensional flows and described a model for the calculation of wave loads on pile template offshore platforms in random directional waves.

In 1985, Bearman, Chaplin, Graham, Kostense, Hall, and Klopman [11] described the results obtained from the measurement of in-line and transverse forces on a small element of a vertical and horizontal cylinder in waves at Keulegan-Carpenter numbers up to 20 and Reynolds numbers up to  $5 \times 10^5$ . The drag and inertia coefficients showed no obvious dependence on  $Re$  and  $\beta$  in the range  $4 < K < 20$ ,  $1.46 \times 10^5 < Re < 5.05 \times 10^5$ ,  $2 \times 10^4 < \beta < 5.49 \times 10^4$ , and  $0.11 < e < 0.65$  where the ellipticity  $e$  is defined as the ratio of **rms** vertical velocity to **rms** horizontal velocity.

A number of other investigations either with oscillating cylinders in an initially still water or with stationary cylinders in wave flumes have been conducted. A critical discussion of these is presented by Hogben, Miller, Searle, and Ward [12], Sarpkaya and Isaacson [4], Sarpkaya and Collins [13], Lin and Nath [14] and by Sarpkaya [10,16,17] and will not be repeated here for sake of brevity.

The degree of spanwise correlation of the wave forces on slender structures has been of special concern for a number of reasons: the interpretation of the data obtained from the measurement of **total** forces (vice sectional forces), the understanding of the reasons for the stochastic behavior of the transverse force, the determination of the hydroelastic response of risers, cables, etc.

In the studies cited above, the length-to-diameter ratio (L/D) of the force-sensing element was as follows:

**Table 1. Some Details of Related Investigations.**

<u>Experiment</u>	<u>Type of motion</u>	<u>L/D</u>
Sarpkaya [1,2]	Planar sinusoidal	5.55-18
OTS [5]	Ocean waves	0.5
CB tests [6]	Ocean waves	≈ 0.6
SSPA tests [7-9]	Planar sinusoidal (and other motions)	1
Bearman et al. [11]	Laboratory waves	0.5
Present study	Planar sinusoidal	2

Tørum and Reed [18] studied the spanwise correlation of transverse forces at different elevations on a pile due to waves in a model basin. The results have shown that the transverse force is very irregular at a given elevation and that at any probability level, the force peak distribution of different combinations of individual force histories yields a force smaller than the sum of the individual force distributions,

i.e., there are significant amplitude and phase modulations in velocity and pressure along the cylinder. This is in part due to variations in both the strength and frequency of vortex segments along the cylinder and in part due to the phase shifts between various sections along the vortex, separated by a correlation length (the equivalent length over which the velocity fluctuations at similar points in the wake may be described as perfectly correlated).

## II. OSCILLATING FLOW SYSTEM

### A. U-SHAPED WATER TUNNEL AND ITS EVOLUTION

A U-shaped water tunnel is used to study the time-dependent resistance on various types of bluff bodies. The tunnel consists of thirteen modules to facilitate construction, transportation and assembly. Each module is made of 3/8 inch aluminum plates which are reinforced with 1/2 in. x 4 in. x 22 in. aluminum flanges welded to the plates. The modules were assembled using an air drying silicon-rubber seal between the module frames. The flanges were held together with one inch steel bolts spaced six inches apart. The interior of each module was precision machined so that the largest misalignment was approximately 0.04 inches. Figure 1 is a sketch showing the front view of the tunnel exterior.

The inside cross-section of the two vertical tunnel legs is 6 ft x 3 ft. and that of the horizontal section is 4.67 ft x 3 ft. The size of these areas is dictated by such conditions

as the available ceiling height, pressures to be encountered, amplitude and period of the oscillations, desired range of Reynolds and Keulegan-Carpenter numbers, boundary layer thickness on the walls, etc.

A sketch of the tunnel interior is shown in Fig. 2. The length of the horizontal test section was made twice as large as the maximum amplitude to ensure fully developed uniform flow at the test section. The corners of the tunnel are streamlined to prevent flow separation.

The ancillary equipment for the tunnel consists of plumbing for filling and draining the tunnel with hot and cold water (50° to 160°F), a heat exchanger and an air supply system.

The tunnel was put in operation on **4 July 1975** in essentially the form as described above with the following exceptions. The dimensions of the horizontal section originally were 3 ft. by 3 ft. The oscillations were created by closing a butterfly valve system (mounted on top of one of the legs of the tunnel) and creating a differential water level between the two legs by introducing sufficient amounts of air (at about 50 psi) into the closed chamber and then releasing it quickly by opening the butterfly valves. This action set the fluid in the tunnel in oscillatory motion with a natural period of  $T = 5.272$  seconds. The damping of the motion was such that the amplitude of oscillation decreased about 0.13 inches per cycle for the largest amplitude and about 0.06 inches per cycle for amplitudes smaller than about half the maximum. This system worked

well for a number of reasons. First, over a period of 4 complete cycles of oscillation at any mean amplitude, the velocity at the test section changed only about 1%. Secondly, the amplitude, velocity, and acceleration signals were absolutely free from noise and required no filter.

Subsequently, the work on the hydroelastic oscillations of cylinders in sinusoidal flow demonstrated the need for a device which will restore the energy lost due to damping of the motion. Furthermore, it was decided to increase the size of the test section to minimize possible blockage effects.

In July 1978, the dimensions of the test section were changed to 4.67 ft by 3 ft by cutting horizontally the vertical walls of the 35 ft section (see Fig. 2) and welding to them two 20-inch high vertical plates. The corners were again streamlined and the tunnel was provided with large windows for easy access and flow visualization. Furthermore, a new air system was designed and constructed to maintain the amplitude of oscillation constant at a prescribed level as long as desired.

Figure 3 shows the layout of the air supply system. A three horsepower motor drives a centrifugal fan and supplies air to the tunnel. The air from the fan passes through an air control box and into a duct. The control box has two gate valves, one at the box entrance and one on top of the box. The entrance valve is raised and lowered vertically by a threaded rod attached to a manually operated gear and allows for a fine adjustment of the air flow. The top valve is opened and closed

by sliding the hatch horizontally and provides a coarse adjustment of the air flow.

The air then flows through the vertical duct to the three-way valve. The control valve permits the air to flow into the tunnel at prescribed time intervals. Figure 4 shows the details of the three-way control valve. The valve body is a drum which is two feet in diameter and four feet long. Four openings were cut into the drum as shown in Fig. 4. The vane inside the drum is used to direct the motion of the air to-and-from the tunnel. The vane rocks about a mean position by means of a connecting rod through a sprocket wheel and chain mechanism (see Fig. 3). The chain is driven by a variable speed motor and gear. The speed of the motor is controlled by an electronic feed-back control system. It increases or decreases the speed of the motor so as to maintain the period of oscillation within  $\pm 0.001$  second about the natural period of the fluid in the tunnel. To insure smooth and uniform rotation of the system, one flywheel is attached to the drive shaft of the connecting rod and another flywheel is attached to the motor drive shaft. Air flows from the duct into the entrance port (marked A in Fig. 4) and is directed by the vane into the tunnel (port B) or to the atmosphere (port D). The vane also provides a smooth flow path for the air escaping from the tunnel (port C) when the supply air is vented to the atmosphere. The plastic flap which rides on the vane further streamlines the path of the escaping air out of the port C.

To oscillate the fluid in the tunnel, the three-way control-valve motor is activated and the centrifugal fan is turned on. The vane rocks back and forth (at a period of  $T = 5.3512 \pm 0.0010$  seconds, where 5.3512 seconds is the natural period of the tunnel for the amount of water admitted into the tunnel), supplying the air to the tunnel and then exhausting it to the atmosphere. The amplitude is controlled by the amount of air supplied to the tunnel by opening or closing the gate valves on the control box. The amplitude, once set, remains constant as long as desired with a maximum variation of less than 0.2% per setting over at least 1000 cycles of oscillation. The small variation is primarily due to the voltage fluctuations at the generating plant.

#### **B. FORCE MEASUREMENTS**

Depending on the type of bluff body and its arrangement, one or two force transducers (shear gages) are used to measure the instantaneous force. The force transducers can measure both the in-line and transverse forces. The force transducer element is manufactured by BLH Electronics, Inc., under the trade name of LBP-1. There are a number of these gages which can offer a variety of load capacities. One typical gage has a 50 pound capacity with an overload capacity of 200 percent. With a 50 pound load, the gage deflection is about 0.01 inches.

The bellows which protects the strain gages is water-proofed by filling the bellows with liquid silicon without

bringing the rubber into contact with air during the filling operation. Then the ends of the bellows are sealed air tight with clamps. The silicon rubber remains in its liquid form and protects the gages when they are subjected to approximately 20 feet of water pressure at temperatures ranging from 50° to 160° F.

The transducer element is mounted on aluminum pedestal blocks. This assembly is then placed inside a gage housing located on the side of the tunnel (see Fig. 5). The probe end of the pedestal block is inserted into a self-aligning bearing located on the end of the bluff body, for example a circular cylinder.

Gage calibration is accomplished by hanging loads from the test body after rotating the gages to sense only a vertical force. Directional sensitivity of the gages was carefully checked by applying upward loads on the test body through the use of a simple pulley system. Following the calibrations in air, the tunnel is filled with hot water (150° F) and the calibration of the gages is checked once again using the buoyant force acting on the water-tight test body (the buoyant force is both calculated and measured precisely prior to the installation of the test body in the tunnel). Repeated calibrations in air as well as in hot water (at various temperatures) have shown that the gages are linear up to the rated load capacity, produce exactly the same signal for upward and downward loads in air and in hot water (under 20 ft water pressure), and can

sense loads as small as 0.02 pounds with proper amplification of the signal. The cross talk between the vertical and side loads is found to be less than 0.2 percent.

The natural frequency of vibration for the gage housing and bluff body assembly is very high, on the order of 100 Hertz. This is much higher than the largest vortex shedding frequency encountered during the experiments.

### **C. ACCELERATION, ELEVATION, AND VELOCITY MEASUREMENTS**

During the past ten years, various methods have been used to determine the characteristics of the ambient flow at the test section. These consisted of (i) the visual observation and recording of the maximum and minimum water levels in both legs of the tunnel; (ii) the use of calibrated platinum capacitance wires in both legs of the tunnel; (iii) the measurement of the instantaneous acceleration by means of a differential-pressure transducer (see [1,2] for additional details) connected to two pressure taps on the legs of the tunnel; (iv) the measurement of the path of neutrally buoyant particles through the use of motion picture films; (v) measurement of the path of a few particles falling in the Stokes regime again through the use of motion picture films; and (vi) the measurement of the velocity in the test section through the use of an LDV system at selected amplitudes of flow oscillation. These methods yielded the ambient flow acceleration, velocity, and displacement with an error less than 0.05%. The signals generated by

the capacitance wires and differential pressure transducers were entirely free from noise and were never filtered.

#### **D. DATA ACQUISITION SYSTEM**

The actual electronic circuitry will vary from one experiment to another depending upon the type of bluff body tested and the type of conditions to which the body is subjected. The following circuits are described for a typical circular cylinder experiment.

The outputs of the two force transducers are amplified by carrier and low-gain amplifiers and then sent to a multichannel recorder for simultaneous analog recording and to a computer system via an A/D converter for analysis and magnetic recording of the digitized data.

The signal sampling rate was chosen to be 720 samples per cycle per channel (i.e., about 135 samples/second/channel or a sample for every 0.5 degrees). The data were recorded for 50 cycles of flow oscillation for each specific experiment and stored on floppy disks and analyzed partly during the experiments (for a quick look) and partly after the experiments (for more detailed analysis of the data).

#### **E. CIRCULAR CYLINDERS**

Four circular cylinders with diameters of 4.5, 5.5, 6.5, and 7.5 inches were tested. Each cylinder was made of three pieces: two fixed dummy ends and one active central piece with

$L/D = 2$  (see Fig. 6). A spacing of approximately  $1/32$  in. was maintained between the active and dummy pieces. The active segment was mounted concentrically on a supporting cylinder whose ends were in turn connected to two force transducers. The ends of the active cylinder were sealed so that the space between the supporting cylinder and the active segment was kept unflooded. The cylinders were first mirror polished and maintained clean during the smooth cylinder experiments. The cylinder surface was wiped clean at the end of each day in order to prevent the development of water marks on the surface. Subsequently, all three parts of a given cylinder were covered with sieved sand so as to maintain a relative surface roughness of  $k/D = 0.02$ . The sand was applied on the cylinder surface with an epoxy resin [1,2]. The cylinder diameter was taken to be  $D(\text{rough}) = D(\text{smooth}) + 1.2 k = 1.024 D$ .

In addition to the foregoing, a marine-roughened cylinder\* was also tested (see Fig. 7). It had a clean diameter of 6.125 inches and an apparent diameter of 8 inches. The roughness consisted mainly of rigid excrescences and there were very little or no flexible roughness elements on it. Portions of the roughness were damaged while the pipe was hanging from a temporary platform in the ocean.

The roughness height was measured at as many locations as possible and the relative roughness was found to be approxi-

---

\* The marine-roughened pipe was kindly provided by Dr. John C. Heideman and the Amoco Production Company.

mately  $k/D = 1/50$ . During most of the experiments the barnacles were alive and uttered a high frequency sound. The intensity of this sound increased when the barnacles were subjected to additional lighting while photographing the pipe. The barnacles remained alive for an additional 48 hours even though the water temperature in the tunnel was raised to about 120 degrees during the first series of tests.

The full 3-ft length of the pipe was used to measure the in-line forces, i.e.,  $L/D = 3$ . The gap between the tunnel wall and one end of the pipe was  $1/32$  inch. The pipe was held at a given position relative to the flow direction (called position A). Following a series of experiments, the pipe was rotated 90 degrees (called position B) and the experiments were repeated. The purpose of this decision was to explore the differences in the force coefficients due to the unevenness of the rigid excrescences. In position A, the damaged parts of the roughness were at the bottom of the cylinder (i.e., at the  $-90$  degree position relative to the ambient flow direction). In position B, the damaged section faced the flow and the top and bottom parts of the cylinder were relatively free from damage. Although the entire data obtained with this pipe are reported herein, only those obtained in position B are compared with those obtained with the sand-roughened cylinders.

The following table summarizes the characteristics of all the cylinders used:

**Table 2. Characteristics of the Test Cylinders.**

**S m o o t h C y l i n d e r s**

<u>Cylinder Name</u>	<u>Diameter</u>	<u>L/D</u>	<u>Ht/D</u>	<u>W/L</u>	<u><math>\beta = D^2/\nu T</math></u>
AS	4.500"	2	12.4	4.00	2300
BS	5.500"	2	10.2	3.27	3435
CS	6.500"	2	8.6	2.77	4720
DS & DSH	7.500"	2	7.5	2.40	6555 & 11525

Ht = height of the test section = 56 inches.

W = width of the test section = 36 inches.

L = length of the active central section = 2 D.

**R o u g h C y l i n d e r s**

<u>Cylinder Name</u>	<u>Diameter</u>	<u>L/D</u>	<u>Ht/D</u>	<u>W/L</u>	<u><math>\beta = D^2/\nu T</math></u>
AR	4.61"	1.95	12.15	4.00	2412
BR	5.63"	1.95	9.95	3.27	3598
CR & CRH	6.66"	1.95	8.41	2.77	4924 & 9354
DR & DRH	7.68"	1.95	7.29	2.40	6836 & 14200
Marine Roughened Cylinder: Pos. A	8 (+)	3	7	3	8100, 10964 13724, 13890
Position B	8	3	7	3	13122, 13517

**III. FORCE COEFFICIENTS AND GOVERNING PARAMETERS**

**A. IN-LINE FORCE**

Data reduction for the forces in-line with the direction of flow oscillation is based on Morison's equation and the Fourier analysis of the force records (sample force traces are shown in Figs. 8-11):

and

$$C_d = -(3/4) \int_0^{2\pi} [F(t) \cos\theta / (\rho U_m^2 D)] d\theta \quad (2)$$

$$C_m = (2K/\pi^3) \int_0^{2\pi} [F(t) \sin\theta / (\rho U_m^2 D)] d\theta \quad (3)$$

in which  $F(t)$  represents the fifty-cycle-averaged measured force per unit length;  $C_d$  and  $C_m$ , the drag and inertia coefficients; and  $U(t)$ , the velocity of the ambient flow [ $U(t) = -U_m \cos\theta$ , with  $\theta = 2\pi t/T$ ]. The method of least squares yields identical  $C_m$  values and slightly different  $C_d$  values.

Two additional coefficients have also been evaluated. These are:

$$C_f(\text{max}) = (\text{Maximum of } F(t) \text{ in a cycle}) / (0.5 \rho D U_m^2) \quad (4)$$

and

$$C_a^2(\text{rms}) = (1/T) \int_0^T F^2(t) dt / (0.5 \rho D U_m^2)^2 \quad (5)$$

## B. TRANSVERSE FORCE (LIFT)

The lift force or the transverse force may be normalized in a number of ways (sample force traces are shown in Figs. 12-15). The fact that the lift force is often random in nature (even for bodies subjected to steady flow) has made the use of its **rms** value most desirable. However, it does not give any idea about the frequency about which the transverse force may

be most dominant. It is for this reason that in the present investigation both the rms value and the first ten harmonics of the normalized lift force were calculated from

$$C_L(\text{rms}) = (\text{rms value of the lift force}) / (0.5 \rho DU_m^2) \quad (6)$$

and

$$F_L(t) = (0.5 \rho DU_m^2) \sum_{n=1}^{10} C_L(n) \cos(n\theta - \phi_n) \quad (7)$$

in which  $C_L(n)$  is the amplitude of the  $n$ -th harmonic and  $\phi_n$  is the phase angle.

The in-line and transverse force coefficients cited above are assumed to be functions of  $K$ ,  $k/D$ , and  $\beta$  (or  $Re$ ) for the cylinder with  $L/D = 2$ .

### C. REMARKS REGARDING THE DATA

The investigation described herein was designed for the purpose of obtaining data which could serve as reference to all concerned. Thus, no effort has been spared in the acquisition and subsequent analysis of the data. Throughout the investigation, conscious attention has been devoted to the integrity of the experimental procedures, methods of evaluation, and the data reported herein.

The raw data (in-line and transverse force versus time) have been preserved on floppy disks. All test cylinders and their components have also been preserved for future use or retesting.

#### IV. PRESENTATION AND DISCUSSION OF RESULTS

##### A. REMARKS

The data are presented in terms of the governing parameters both in graphical and tabulated form (see Appendices). Unless stated, **none of the results have been corrected for tunnel blockage.**

##### B. SMOOTH CYLINDER DATA

The drag and inertia coefficients for five values of  $\beta$  are shown in Figs. 16-20 (see Appendix A for the tabulated data). It is clear from the perusal of either one of these figures that  $C_d$  decreases rapidly as  $K$  increases from very small values and reaches a minimum between  $K \approx 2$  and  $K \approx 3$ , depending on the value of  $\beta$ .

Stokes [19] was the first to show that the force acting on a cylinder or sphere oscillating sinusoidally in a viscous fluid is dependent on both  $K$  and  $Re$  (or  $\beta$ ). In the case of a **fixed** circular cylinder in a sinusoidally oscillating flow Stokes force may be expressed in terms of the MOJS equation by noting that over a flow cycle  $\cos\theta |\cos\theta|$  may be approximated by  $(8/3^{1/2})\cos\theta$ . Then one has (see also Rosenhead [20], p. 392),

$$C_d = (3^{-3/2}K) [(\pi\beta)^{-1/2} + (\pi\beta)^{-1} + O(\pi\beta)^{-3/2}] \quad (8)$$

and

$$C_m = 2 + 4(\pi\beta)^{-1/2} + O(\pi\beta)^{-3/2} \quad (9)$$

Equations (8) and (9) are valid only for large values of  $\beta$ . Wang [21] extended this analysis to  $O[(\pi\beta)^{-3/2}]$  using the

method of inner and outer expansions. His solution, valid for  $K \ll 1$ ,  $\text{Re} \cdot K \ll 1$ , and  $\beta \gg 1$ , may be reduced to

$$C_d = (3\pi^3/2K) [(\pi\beta)^{-1/2} + (\pi\beta)^{-1} - (1/4)(\pi\beta)^{-3/2}] \quad (10)$$

and

$$C_m = 2 + 4(\pi\beta)^{-1/2} + (\pi\beta)^{-3/2} \quad (11)$$

The expressions (10) and (11) differ from (8) and (9) only in the last terms. Stokes and Wang's solutions yield virtually identical results in the range of their validity, i.e., for large  $\beta$ .

Relatively few experiments have been carried out with sinusoidally oscillating cylinders at low Keulegan-Carpenter numbers. Honji [22] oscillated a circular cylinder in water at rest in the range  $70 < \beta < 700$  and  $0 < K < 4$ , and investigated the stability of the flow. He has delineated three regions in the  $(K, \beta)$ -plane: a region (corresponding to relatively small  $K$ ) in which no streaks formed because the flow remained attached, stable and two-dimensional; a second region in which the flow became unstable to axially periodic vortices; and a third region in which no clear streaks formed because the flow became turbulent.

Subsequently, Hall [23] carried out a stability analysis of that flow, valid only in the limit  $\beta \rightarrow \infty$  and  $K \rightarrow 0$ , and showed that 'oscillatory viscous flows interacting with rigid boundaries of convex curvature can become unstable to Taylor-Görtler vortices'. His analysis confirmed Honji's data.

Hall's critical Keulegan-Carpenter number may be written as

$$K_{Cr} = Re_{Cr}/\beta = 5.778\beta^{-1/4}(1 + 0.205\beta^{-1/4} + \dots) \quad (12)$$

according to which the critical Reynolds number  $Re_{Cr}$  increases with increasing  $\beta$ .

Subsequently, Sarpkaya [24] presented in-line force data for one rough and three smooth cylinders over a large range of  $\beta$  (1035 to 5500) and has shown that (i) the theoretical values of the inertia coefficient agree quite well with those obtained experimentally for  $K$  smaller than that corresponding to the inception of boundary-layer transition; (ii) the drag coefficient predicted by the Stokes-Wang analysis agrees well with that obtained experimentally for  $K < K_{Cr}$  at which the flow becomes unstable (Honji instability); (iii) the critical regime is followed either by separation and transition or by transition and delayed separation. In either case, separation and minimum drag occur almost simultaneously; (iv) roughness precipitates instability and transition to turbulence in the boundary layers. Its net effect is to increase  $C_d$ , relative to the Stokes-Wang prediction, and to delay separation.

The purpose of the present study was not a further investigation of the stability of the flow at very low  $K$  values. Thus, the experiments were confined to  $K$  values larger than about 1. According to Eq. (12), the critical values of  $K$  and  $Re$  for  $\beta = 2300$  are about 0.86 and 1976, respectively. Thus,

the instability and the rapid change in  $C_D$  [24] are not evident in Figs. 16-20 for which the lowest  $K$  is about 1.0. The comparison of the Stokes-Wang prediction with the present measurements shows that (see Figs. 16-20) the instability has occurred at smaller  $K$  values and the drag coefficient jumped to higher values. The delay in separation due to transition in the boundary layer leads to minimum  $C_D$  values which occur at slightly larger  $K$  values with increasing  $\beta$  (for additional discussion the reader is referred to [24]).

Figures 16-20 also show that the inertia coefficient is slightly large than 2, at least for  $K$  smaller than that corresponding to the minimum drag, and nearly identical to that given by Eq. (11). The ideal values of  $C_m$  are as follows:

**Table 3. Ideal Values of the Inertia Coefficient for Various Values of  $\beta$  for Smooth and Sand-Roughened Cylinders**

$\beta = 2300$	$C_m = 2.047$	$\beta = 2412$	$C_m = 2.046$
$= 3435$	$= 2.039$	$= 3598$	$= 2.038$
$= 4720$	$= 2.033$	$= 4924$	$= 2.032$
$= 6555$	$= 2.028$	$= 6836$	$= 2.027$
$= 11525$	$= 2.020$	$= 9354$	$= 2.023$
		$= 14200$	$= 2.019$

These may be compared with the tabulated data (Appendices A & D) to see that the measured and calculated values of  $C_m$  agree fairly well in the range of  $K$  values noted above.

In the range of  $K$  values between approximately 3 and 12,  $C_D$  increases and  $C_m$  decreases as the effects of flow separation and vortex shedding become increasingly important, eventually

leading to a very interesting half Karman vortex street in the transverse direction in the range  $8 < K < 13$  (Bearman [25], Sarpkaya [10, 26], Williamson [27]). Subsequently,  $C_m$  increases, rapidly at first and then slowly, and  $C_d$  decreases with increasing  $K$ .

The drag and inertia coefficients are compared in Figs. 21 and 22 for  $\beta = 6555$  and  $\beta = 11525$ . It is noted from Fig. 21, as well as from Figs. 16-20, that  $C_d$  does not depend (within the range of the experimental errors) on  $\beta$  for  $\beta > 2300$  and  $K$  smaller than about 1.5. The dependence of boundary-layer transition and separation on  $K$  becomes evident for  $K$  larger than about 1.5. For  $K$  larger than about 3, larger values of  $\beta$  yield smaller  $C_d$  and larger  $C_m$  values. The dip in  $C_m$  in the range  $10 < K < 15$  becomes less and less significant as  $\beta$  increases (e.g.,  $C_m = 0.5$  at  $K = 14$  for  $\beta = 2300$  and  $C_m = 1.4$  at  $K = 11$  for  $\beta = 11525$ ). This behavior of the inertia coefficient for smooth cylinders is opposite to that for the rough cylinders, as will be shown later.

For  $K > 15$ , the two values of  $\beta$  (corresponding to  $Re = 98,300$  and  $172,875$ , both for  $K = 15$ ) yield nearly identical  $C_d$  values. This does not mean that  $C_d$  becomes independent of  $Re$  for all values of  $Re$ . It simply means that  $C_d$  becomes nearly insensitive to changes in  $Re$  in the range of  $Re$  values from  $6555.K$  to  $11525.K$  for  $K > 15$  for the data shown in Fig. 21. Similar observations may be made regarding  $C_m$  on the basis of Fig. 22.

Figure 23 shows, for  $K = 20$ , a comparison of the data obtained in 1976 by Sarpkaya [1,2] with those deduced from Figs. 16-20. The agreement between the two sets of data is quite good. The present values of  $C_D$  are slightly larger than the previous ones. This is attributed to the better correlation of the flow along the shorter length ( $L = 2.D$ ) of the present test cylinders. Similar comparisons may be made by the reader at other  $K$  values using the tabulated data reported in 1976 [1] and in the present investigation.

Figures 24 and 25 show the drag and inertia coefficients, respectively, for four sets of data (Rodenbusch and Gutierrez [7], Sarpkaya [1,2], Bearman et al. [11], and the present data). The following observations may be made: (i) the present data (in the range  $10^5 < Re < 4 \times 10^5$ ) agree reasonably well with those reported by Sarpkaya [1,2] in 1976 and by Rodenbusch & Gutierrez [7] in 1983; (ii) Bearman et al.'s [11] drag coefficients are somewhat lower in the range of comparison (i.e., for  $K < 20$ ) than those of Rodenbusch & Gutierrez. The reasons for this difference are not clear. However, one is tempted to attribute them to the effect of the orbital motion and to the presence of currents in wave channels. Sarpkaya and Storm [28] have shown that the effect of current is to reduce the drag coefficient relative to the no-current case, particularly for  $K < 20$ ; and (iii) the agreement between the present data, Sarpkaya's 1976 data and Rodenbusch & Gutierrez's 1983 data for  $K$  larger than about 15 support the view that  $C_D$  is at best a

very weak function of  $Re$  for  $Re$  larger than about  $10^5$  (in Fig. 24,  $Re$  ranges from  $10^5$  to  $18.8 \times 10^5$ ).

Figure 26 shows the present  $C_{fmax}$  data as a function of  $K$  for all values of  $\beta$  (from 2,300 to 6,555) for the smooth cylinders (see Appendix A for the tabulated data).

For  $K < 9$ ,  $C_{fmax}$  is independent of  $\beta$  in the range of  $\beta$  values noted above. For  $K > 9$ , the maximum in-line force coefficient depends on  $\beta$  as well as on  $K$ . However, the dependence of  $C_{fmax}$  on  $\beta$  decreases rapidly with increasing  $\beta$ . In other words, for large values of  $\beta$ ,  $C_{fmax}$  depends only on  $K$  within the range of  $\beta$  values encountered in the present investigation.

The rms value of the lift coefficient for smooth cylinders is shown in Fig. 27\* (see Appendix B for the tabulated data). In the range  $2300 < \beta < 11525$ ,  $C_{Lrms}$  reaches a peak value of about 1.6. For  $K$  larger than about 13, the dependence of  $C_{Lrms}$  on  $\beta$  decreases rapidly with increasing  $\beta$ . The data shown in Fig. 27 are quite similar to those reported in 1976 [1].

The amplitudes of the first five harmonics of the lift force for the smooth cylinders are shown in Figs. 28-31 (see Appendix C for the tabulated data). Clearly, all harmonics are present, to varying degrees of importance, in the lift force. However, the second and fourth harmonics dominate the drag/inertia dominated regime. The third harmonic is relatively

---

\* The lift data for smooth cylinders were obtained only at  $\beta = 2300, 3435, 4720, \text{ and } 6555$  (i.e., with water at room temperatures only).

strong in the neighborhood of  $K = 18$ . One additional observation to be made is that the importance of all harmonics, with the exception of the second and the fourth, decreases rapidly with increasing  $\beta$  (see Fig. 31). Thus, the transverse force should be well represented by its second and fourth harmonics in the drag/inertia dominated regime at sufficiently high Reynolds numbers (say  $Re$  larger than about 50,000).

### C. ROUGH CYLINDER DATA

The drag and inertia coefficients for the sand-roughened cylinders ( $k/D = 1/50$ ) are shown in Figs. 32 through 37 for  $\beta$  from 2412 to 14200 (see Appendix D for the tabulated data). Several facts emerge from these figures. The drag coefficient decreases with  $K$  for  $K$  smaller than about 2 and then rises to a maximum near  $K = 10$ . Subsequently,  $C_D$  decreases with increasing  $K$  within the range of  $K$  values encountered. The said decrease in  $C_D$  is not smooth and there are several humps or increases and decreases in  $C_D$ . The first of these increases occurs at  $K \approx 17$ , the second at  $K \approx 24$ , and the third at  $K \approx 32$ . The amplitude of these secondary oscillations in  $C_D$  decreases with increasing  $K$ . Repeated experiments have shown that these oscillations are not only real but also are directly related to the harmonics of the lift force. It will be shown later that the first, third, and fifth harmonics at  $K \approx 17$ , the fourth, sixth, and eighth harmonics at  $K \approx 24$ , and the fifth, seventh, and ninth harmonics at  $K \approx 32$  are very prominent. This

is reflected in the variation of the drag coefficient in the said range of  $K$  values.

The inertia coefficient starts out at values slightly larger than 2, then decreases rather rapidly at  $K \approx 7$ , and then increases, rapidly at first and then gradually. Figures 31-34 also show that  $C_m$  decreases with increasing  $\beta$  (from 2412 to 4924) in the range  $10 < K < 15$ . As noted earlier, this is contrary to the variation of  $C_m$  with  $\beta$  for the smooth cylinder.

The dependence on  $\beta$  of the drag and inertia coefficients for the rough cylinders will be discussed through the use of Figs. 38-41. Figure 38 is a combined plot of the drag and inertia coefficients for  $\beta = 6836$  and  $\beta = 14,200$ . The corresponding sets of data (including the magnitude and position of the secondary oscillations in  $C_d$ ) are nearly coincident.\* It is clear that  $C_d$  and  $C_m$  do not depend on  $\beta$  for the two values of  $\beta$  noted above. In other words, the drag and inertia coefficients in Fig. 38 vary only with  $K$  and are independent of the Reynolds number.

One is now in a position to explore the dependence or lack of dependence of the force coefficients on  $\beta$  over a larger range of  $\beta$ .

---

\* This is more remarkable than it may appear at first sight. It is recalled that the experiments at  $\beta = 6836$  were carried out in water at room temperature and those at  $\beta = 14,200$  in hot water at nearly twice the room temperature. Furthermore, each experiment was repeated twice at different times over a one month period.

Figure 39 shows  $C_d$  and  $C_m$  for four values of  $\beta$  (4924, 6836, 9354, and 14,200; see Table 2 for the cylinders used). Once again it is noted that the force coefficients do not depend on  $\beta$  in the range of  $\beta$  values noted. The differences between the four sets of data are no more than the scatter in any one set.

Figure 40 shows the entire drag-coefficient data for all values of  $\beta$  (from 2412 to 14,200) for the sand-roughened cylinders. This figure and the tabulated data (see Appendix D) show that  $C_d$  values for  $\beta = 2412$  are lower than the rest. The  $C_d$  values for  $\beta = 3598$  are sandwiched between those for  $\beta = 2412$  and the rest. One may, therefore, conclude that for rough cylinders ( $k/D = 1/50$ ) the drag coefficient becomes independent of  $\beta$  or of the Reynolds number for  $\beta$  larger than about 4,000 ( $\pm 200$ ). Even though the data at large  $\beta$  were obtained for  $K$  smaller than about 40, there is no reason to expect that  $C_d$  will become dependent on  $Re$  for  $K > 40$  as long as the Reynolds number is kept larger than about 4,000.  $K$ , for  $k/D = 1/50$ .

Figure 41 shows the inertia coefficient for all values of  $\beta$  (from 2412 to 14,200). This figure and the tabulated data show that  $C_m$  becomes independent of  $\beta$  for  $\beta$  larger than about 4,000. It is also noted that the dependence of the inertia coefficient on  $\beta$  (or on the Reynolds number) for  $\beta < 4000$  is relatively weaker than that of the drag coefficient. Furthermore, variations in  $C_m$  with  $\beta$  for  $K$  larger than about 15 are obscured by the scatter in the data in the drag dominated regime (where the precise value of  $C_m$  is not of special concern).

Figures 42 and 43 show, for  $K = 20$  and  $K = 30$  respectively, the comparison of the drag coefficients obtained in the present investigation with those reported in 1976 by Sarpkaya [2]. For  $K = 20$  and  $k/D = 1/50$ , the two sets of data agree quite well and show that  $C_D$  becomes independent of  $Re$  for  $Re$  larger than about 80,000 (i.e., for  $\beta > 4000$ ). For  $K = 30$ , the mean of the present data is slightly lower (about 3%) than that reported in 1976. The drag coefficient becomes independent of  $Re$  for  $Re > 120,000$  (i.e., for  $\beta > 4000$ ). Figures 42 and 43 also show that for smaller relative roughnesses,  $C_D$  and  $C_m$  become independent of  $\beta$  at larger values of  $\beta$ , i.e., at larger  $Re$  for a given  $K$ .

Figures 46 and 47 show  $C_D$  and  $C_m$  for the marine-roughened cylinder (in position A) for various values of  $\beta$ . The relatively large scatter in  $C_m$  is attributed to the damage in roughness near the separation region on one side of the cylinder.

Figures 46 and 47 show  $C_D$  and  $C_m$  for the same cylinder in position B. The scatter in  $C_m$  is relatively smaller. The magnitude of  $C_D$  in the drag-inertia dominated regime is somewhat larger than that shown in Fig. 44. The said difference is attributed to the orientation of the damaged roughness in the two cases.

Figures 48 and 49 show a comparison of the drag and inertia coefficients for three sets of data: the present sand-roughened cylinder data (for  $\beta = 9354$  and  $\beta = 14,200$  only, for

sake of clarity); the marine-roughened cylinder data (for the position B); and the rough cylinder data of Rodenbusch and Gutierrez [7], all for  $k/D = 1/50$ . The sand-roughened and marine-roughened cylinder data agree quite well. Six of the  $C_D$  values\* of Rodenbusch and Gutierrez are somewhat lower than those obtained in the present investigation. Furthermore, their  $C_m$  values for  $K > 12$  are somewhat larger. The reasons for these differences are not clear. However, the facts presented herein show that they are not attributable either to the differences in  $\beta$  or to the blockage effects in the U-tunnel. It is tempting to think that the vibrations of the large test cylinder, the condition of the free surface in the test basin, the filtering of the data and the regularity of the shape and distribution of the roughness elements in the SSPA tests [7] may be partly responsible for the said differences<sup>†</sup>.

Figure 50 shows  $C_{fmax}$  as a function of  $K$  for all values of  $\beta$  (from 2412 to 14,200) for the sand-roughened cylinders (see Appendix D for the tabulated data). For  $K < 7$ ,  $C_{fmax}$  is inde-

---

\* The six data points are at:  $K = 3.14$  for  $Re = 440,000$  and  $\beta = 140,000$ ;  $K = 6.28$  for  $Re = 440,000$  and  $\beta = 70,000$ ;  $K = 12.56$  for  $Re = 880,000$  and  $\beta = 70,000$ ;  $K = 25.12$  for  $Re = 1,880,000$  and  $\beta = 75,000$ ;  $K = 31.4$  for  $Re = 880,000$  and  $\beta = 28,000$ ; and  $K = 31.4$  for  $Re = 1,750,000$  and  $\beta = 56,000$ .

---

<sup>†</sup> The increase of  $D(\text{smooth})$  by  $2k$  in [7] rather than by  $1.2k$  (as in the present study) in calculating  $D(\text{rough})$  lowers  $C_D$  by only 2% and thus cannot account for the differences noted above.

pendent of  $\beta$  in the range of  $\beta$  values noted above. For  $K > 7$ , the maximum in-line force coefficient depends on  $\beta$  as well as on  $K$ . However, the dependence of  $C_{fmax}$  on  $\beta$  is rather weak and decreases rapidly with increasing  $\beta$ . For  $\beta > 2412$ , it is difficult to make a distinction between a negligible dependence on  $\beta$  and a small scatter in the data.

The  $C_{fmax}$  values for a smooth ( $\beta = 11,525$ ) and a sand-roughened cylinder ( $\beta = 14,200$ ) are compared in Fig. 51. This figure and Figs. 26 and 50 show conclusively that (i) the maximum force coefficient does not depend on either the relative roughness or  $\beta$  for  $K < 7$ ; (ii)  $C_{fmax}$  for the rough cylinder is considerably larger than that for the smooth cylinder for  $K > 7$ ; and (iii) as noted earlier,  $C_{fmax}$  for the smooth cylinder continues to be independent of  $\beta$  up to  $K = 9$ .

The rms value of the lift coefficient for sand-roughened cylinders is shown in Fig. 52\* (see Appendix E for the tabulated data). In the range  $2412 < \beta < 6836$ ,  $C_{Lrms}$  reaches a peak value of about 1.8 and is practically independent of  $\beta$  ( $C_{Lrms}$  for  $\beta = 2412$  is slightly lower than the rest). The secondary oscillations in the rms value of the lift coefficient occur at  $K \approx 17, 24, 32, \text{ and } 41$ . These are the same  $K$  values at which similar oscillations with relatively smaller amplitudes occur in  $C_d$  (see Figs. 32-40).

---

\* The lift data for the sand-roughened cylinders were obtained only at  $\beta = 2412, 3598, 4924, \text{ and } 6836$  (i.e., with water at room temperatures only).

Figure 53 shows a comparison of the  $C_{Lrms}$  values of a smooth ( $\beta = 6555$ ) and a rough cylinder ( $\beta = 6836$ ) for nearly identical  $\beta$  values. Clearly,  $C_{Lrms}$  for the rough cylinder remains high and its maximum occurs at a lower  $K$  relative to the smooth cylinder. The implications of these are that the separation occurs at a smaller angle at a given time relative to that for the smooth cylinder and the vortices are stronger and better correlated.

The amplitude of the first five harmonics of the lift force for the sand-roughened cylinders are shown in Figs. 54-57 (see Appendix F for the tabulated data). Clearly, all harmonics are present, to varying degrees of importance, in the lift force. In the drag-inertia dominated regime, primarily the second harmonic and to a lesser but equal extent the first, third, and fourth harmonics dominate the lift. The third and fifth harmonics in the neighborhood of  $K = 17$ ; the fourth, sixth, and eighth harmonics in the vicinity of  $K = 24$ ; and the fifth and seventh harmonics in the neighborhood of  $K = 32$  dominate the lift. What is rather remarkable is that all harmonics, with the exception of the second, are of the same order of magnitude (see also the tabulated data in Appendix F). A comparison of Figs. 54-57 with Figs. 28-31 shows that the effect of roughness is to increase significantly the importance of higher order harmonics in the transverse force. It is suggested that the roughness increases the wall shear, the boundary layer thickness, and the spanwise coherence, decreases the

separation angle, and increases the vorticity flux and hence the strength and the lifespan of the vortices relative to those for the smooth cylinder. The measurement of the vortex strength and the separation angle as a function of time is at best very difficult. The consequences of roughness, as reflected indirectly in the time-invariant in-line and transverse force coefficients, cannot yet be predicted theoretically. The application of the discrete vortex model to oscillating flow about a smooth cylinder will be the subject of another report.

## V. CONCLUSIONS

The results presented herein warrant the following conclusions:

1. The smooth-cylinder data presented herein agree quite well with those presented by Sarpkaya [1,2] in 1976 and by Rodenbusch and Gutierrez [7] in 1983;

2. Bearman et al.'s [11] drag coefficients are somewhat lower in the range of comparison (i.e., for  $K < 20$ ) than those of Rodenbusch and Gutierrez [7];

3. The drag, inertia, and the maximum force coefficients for smooth cylinders are at best a very weak function of the Reynolds number ( $Re$ ) for  $Re$  larger than about 100,000;

4. The rms value of the lift coefficient for smooth cylinders reaches a peak value of about 1.6. For Keulegan-Carpenter numbers ( $K$ ) larger than about 13, the dependence of  $C_{Lrms}$  on  $\beta$  ( $= Re/K$ ) decreases rapidly with increasing  $\beta$ ;

5. The analysis of the amplitude of the first ten harmonics of the lift force for smooth cylinders has shown that all harmonics are present, to varying degrees of importance, in the lift force. However, the second and fourth harmonics dominate the drag-inertia dominated regime. The amplitude of all harmonics, with the exception of the second and the fourth, decreases rapidly with increasing  $\beta$ ;

6. For rough cylinders ( $k/D = 1/50$ ), the drag and inertia coefficients become independent of  $\beta$  or of the Reynolds number for  $\beta$  larger than about 4000;

7. The drag coefficient exhibits pronounced secondary peaks in the neighborhood of  $K = 17, 24, \text{ and } 32$ . These are directly related to the harmonics of the lift force;

8. The rough-cylinder data presented herein agree quite well with those reported by Sarpkaya [2] in 1976 and show that the effect of roughness, particularly on the drag coefficient, is indeed very profound. The rough-cylinder drag-coefficient data of Rodenbusch and Gutierrez [7] are somewhat lower than those obtained in the present investigation. Their inertia coefficients for  $K > 12$  are somewhat larger. The reasons for these differences are not clear. However, the facts, presented herein show that they are not attributable either to the differences in  $\beta$  or to the blockage effects in the U-tunnel;

9. The maximum force coefficient does not depend on either the relative roughness or  $\beta$  for  $K < 7$ ;

10. The rms value of the lift coefficient reaches a peak value of about 1.8 and is practically independent of  $\beta$ . The secondary oscillations in the rms value of the lift coefficient occur at  $K \approx 17, 24, 32,$  and  $41$ . These are the same  $K$  values at which similar oscillations with relatively smaller amplitudes occur in the drag coefficient;

11. The analysis of the harmonics of the lift force for rough cylinders shows that all harmonics, with the exception of the second, are of the same order of magnitude. In the drag-inertia dominated regime, primarily the second harmonic and to a lesser but equal extent the first, third, and fourth harmonics dominate the lift. The third and fifth harmonics in the neighborhood of  $K = 17$ ; the fourth, sixth, and eighth harmonics in the vicinity of  $K = 24$ ; and the fifth and seventh harmonics in the neighborhood of  $K = 32$  dominate the lift force.

12. The use of relatively short test cylinders with identical length-to-diameter ratio ( $L/D = 2$ ) brought into sharper focus the variation of all force coefficients and effectively removed the ambiguities associated with the use of test cylinders with different  $L/D$  ratios.

## REFERENCES

1. Sarpkaya, T., "Vortex Shedding and Resistance in Harmonic Flow About Smooth and Rough Circular Cylinders at High Reynolds Numbers," **Technical Report No. NPS-59SL76021**, Feb. 1976, Naval Postgraduate School, Monterey, CA.
2. Sarpkaya, T., "In-Line and Transverse Forces on Smooth and Sand-Roughened Circular Cylinders in Oscillating Flow at High Reynolds Numbers," **Technical Report No. NPS-69SL76062**, June 1976, Naval Postgraduate School, Monterey, CA.
3. Schlichting, H., "Berechnung ebener Periodischer Grenzschichtströmungen," **Phys. Z.**, Vol. 33, 1932, pp. 327-335.
4. Sarpkaya, T. and Isaacson, M., Mechanics of Wave Forces on Offshore Structures, Van Nostrand Reinhold, New York, N. Y., 1981.
5. Heideman, J. C., Olsen, O. A., and Johansson, P. I., "Local Wave Force Coefficients," **Civil Engineering in the Oceans IV, ASCE**, 1979, pp. 684-699.
6. Bishop, J. R., "Wave Force Investigations at the Second Christchurch Bay Tower," **National Maritime Institute Report No. R177**, OT-0-82100, 1982.
7. Rodenbusch, G. and Gutierrez, C. A., "Forces on Cylinders in Two-Dimensional Flow," **Technical Report, Vol. 1, BRC 13-83**, May 1983, Bellaire Research Center (Shell Development Co.), Houston, TX.
8. Rodenbusch, G. and Källström, C., "Forces on a Large Cylinder in Random Two-Dimensional Flows," **OTC-5096**, May 1986, Houston, TX.
9. Rodenbusch, G., "Random Directional Wave Forces on Template Offshore Platforms," **OTC-5098**, May 1986, Houston, TX.
10. Sarpkaya, T., "Past Progress and Outstanding Problems in Time-Dependent Flow About Ocean Structures," in Proc. of **Separated Flow Around Marine Structures**, Trondheim, Norway 1985, pp. 1-36, The Norwegian Institute of Technology, Trondheim, Norway.
11. Bearman, P. W., Chaplin, J. R., Graham, J. M. R., Kostense, J. R., Hall, P. F., and Klopman, G., "The Loading of a Cylinder in Post-critical Flow Beneath Periodic and Random Waves," Prof. of **BOSS 1985**, Elsevier Sci. Pub., Amsterdam, 1985, pp. 213-225.

12. Hogben, N., Miller, B. L., Searle, J. W., and Ward, G., "Estimation of Fluid Loading on Offshore Structures," **Proc. Institution of Civil Engineers**, Vol. 63, Part 2, 1977, pp. 515-562.
13. Sarpkaya, T. and Collins, N. J., Discussion of "Drag and Inertia Forces on a Cylinder in Periodic Flow" (by C. J. Garrison et al., Jour. Waterways etc. Div. ASCE, Proc. Paper No. 12913), **Jour. of Waterways etc. Div., ASCE**, WW1, 1978, pp. 96-98.
14. Lin, C.-W. and Nath, J. H., "Fluid Forces on Smooth and Rough Circular Cylinders," **An Interim Report to NSF**, Dec. 1980, Oregon State Univ., Corvallis, Oregon.
15. Chakrabarti, S. K., "Impact of Analytical, Model and Field Studies on the Design of Offshore Structures," In **Proc. of International Symposium in Ocean Engineering Ship Handling**, Swedish Maritime Research Center, SSPA, 1980, pp. 6.1-6.79, Gothenburg, Sweden.
16. Sarpkaya, T., "A Critical Assessment of Morison's Equation and Its Applications," in **Proc. of the International Conference on Hydrodynamics in Ocean Engineering**, Trondheim, Norway, 1981, pp. 447-467, The Norwegian Institute of Technology, Norway.
17. Sarpkaya, T., "Morison's Equation and the Wave Forces on Offshore Structures," **Naval Civil Engineering Lab., Report No. CR82.008**, 1981, Port Hueneme, CA.
18. Tørum, A. and Reed, K., "On the Spanwise Correlation of Wave Forces on Slender Structures," **OTC-4226**, May 1982, Houston, TX.
19. Stokes, G. G., "On the Effect of the Internal Friction of Fluids on the Motion of Pendulums," **Trans. Cambridge Phil. Soc.**, Vol. 9, 1851, pp. 8-106.
20. Rosenhead, L. (ed.), **Laminar Boundary Layers**, Clarendon, London, 1963.
21. Wang, C.-Y., "On High-Frequency Oscillating Viscous Flows," **Jour. of Fluid Mechanics**, Vol. 32, 1968, pp. 55-68.
22. Honji, H., "Streaked Flow Around an Oscillating Circular Cylinder," **Jour. of Fluid Mechanics**, Vol. 107, 1981, pp. 509-520.
23. Hall, P., "On the Stability of Unsteady Boundary Layers on a Circular Cylinder Oscillating Transversely in a Viscous Fluid," **Jour. of Fluid Mech.**, Vol. 146, 1984, pp. 347-367.

24. Sarpkaya, T., "Force on a Circular Cylinder in Viscous Oscillating Flow at Low Keulegan-Carpenter Numbers," **Jour. of Fluid Mechanics**, Vol. 165, 1986, pp. 61-71.
25. Bearman, P. W., "Vortex Trajectories in Oscillating Flow," in **Proc. of Separated Flow Around Marine Structures**, Trondheim, Norway, 1985, pp. 133-153, The Norwegian Institute of Technology, Trondheim, Norway.
26. Sarpkaya, T., "On Fluid Loading of Offshore Structures- After Ten Years of Basic and Applied Research," in the **Proc. of Offshore Operations Symposium**, 1986, New Orleans, Louisiana, PD-Vol. 1, pp. 153-164, ASME, N. Y.
27. Williamson, C. H. K., "Sinusoidal Flow Relative to Circular Cylinders," **Jour. of Fluid Mechanics**, Vol. 155, 1985, pp. 141-174.
28. Sarpkaya, T. and Storm, M., "In-line Force on a Cylinder Translating in Oscillating Flow," **Applied Ocean Research**, Vol. 7, No. 4, 1985, pp. 188-196.

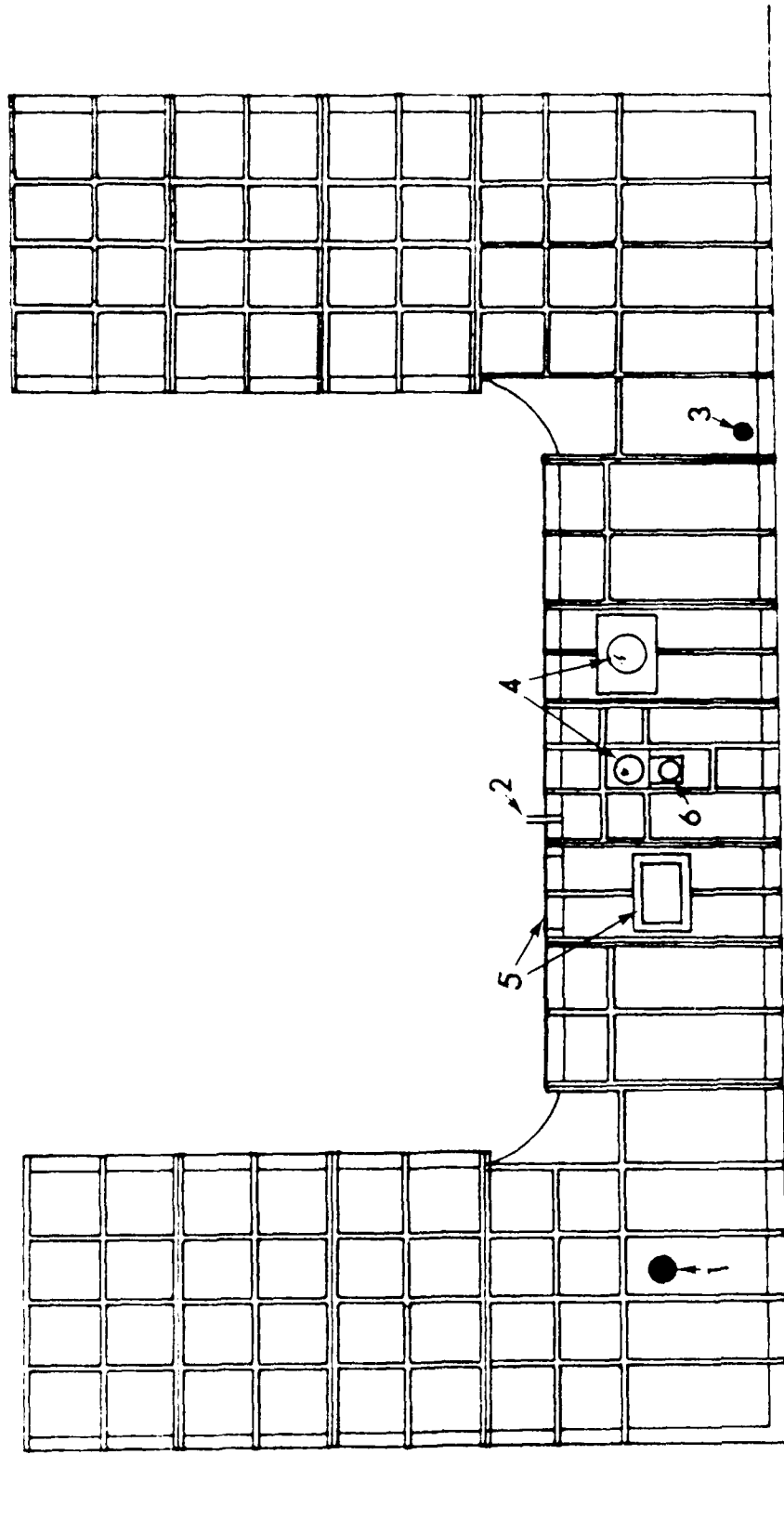

Fig. 1 A sketch of the exterior of the water tunnel (not to scale).  
1 & 3: inlets, 4 & 5: windows, 2: air vent; 6: location of test body.

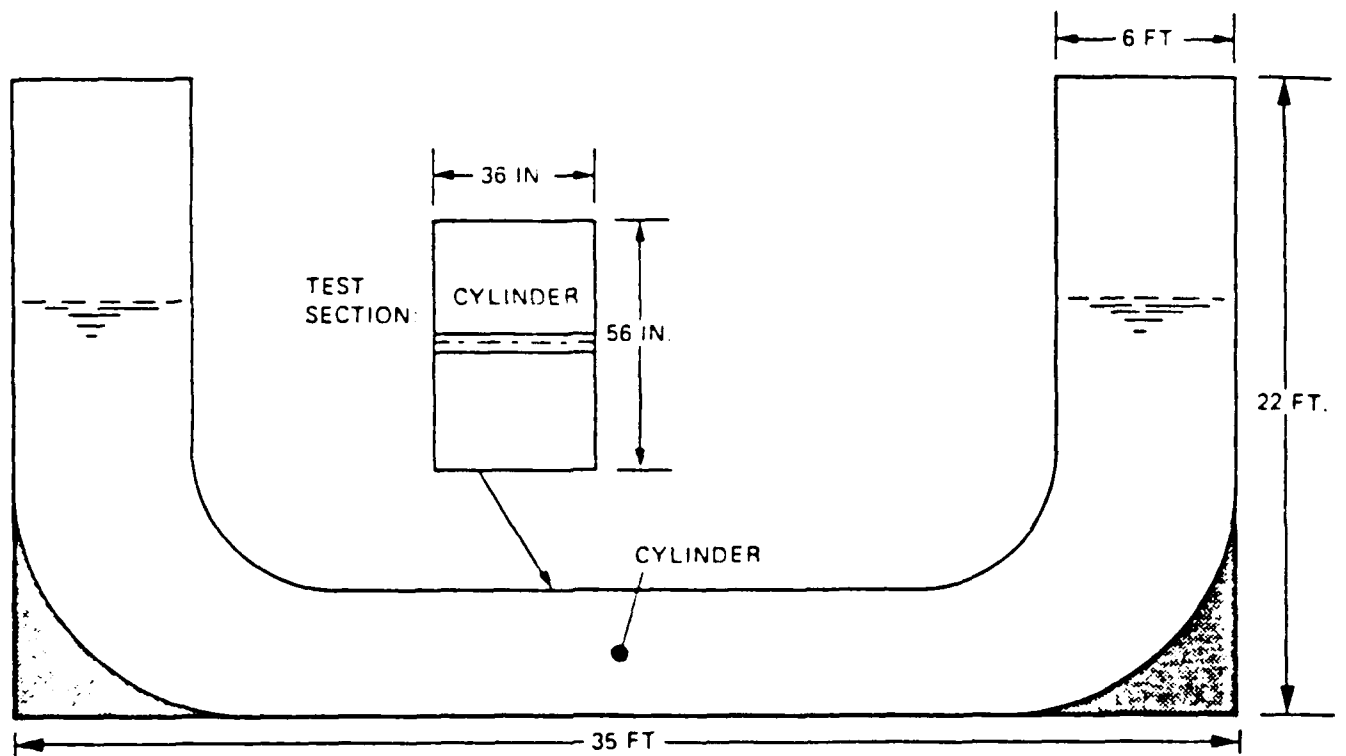

Fig. 2a Cross-section of the U-shaped water tunnel.

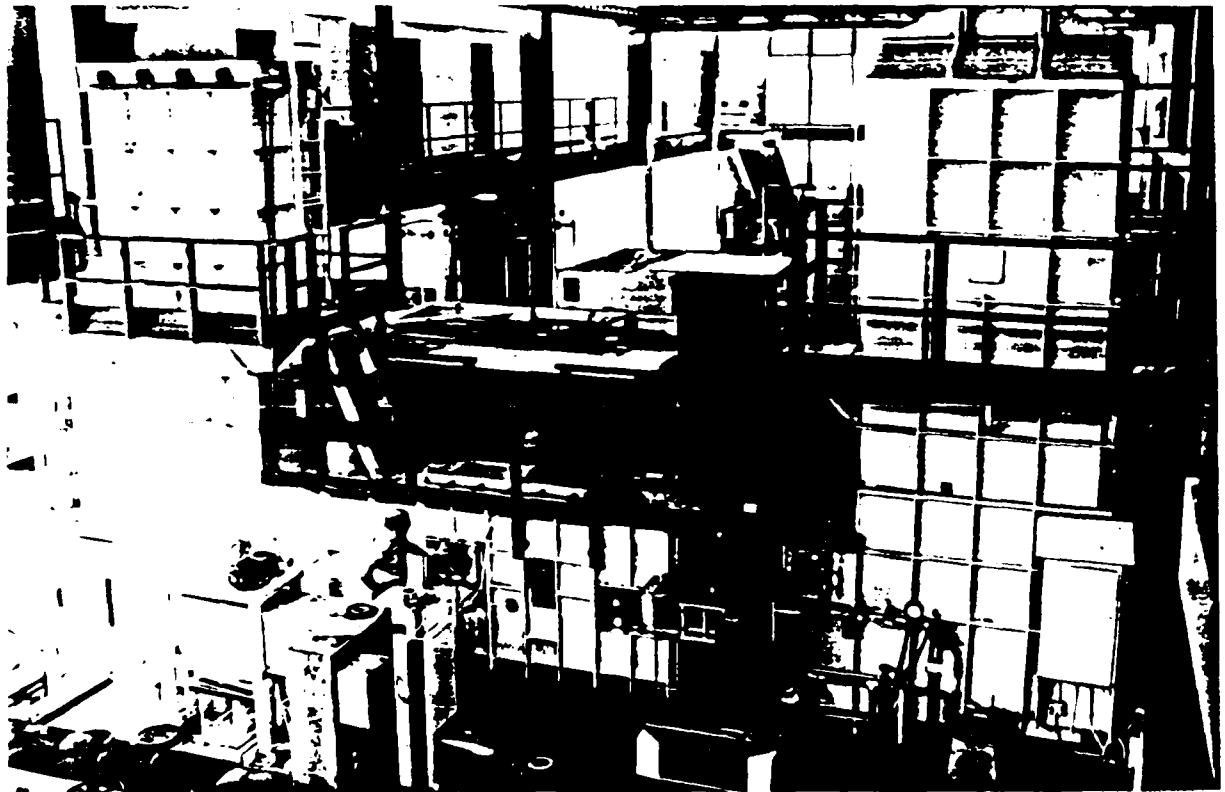

Fig. 2b A photograph of the U-shaped water tunnel.

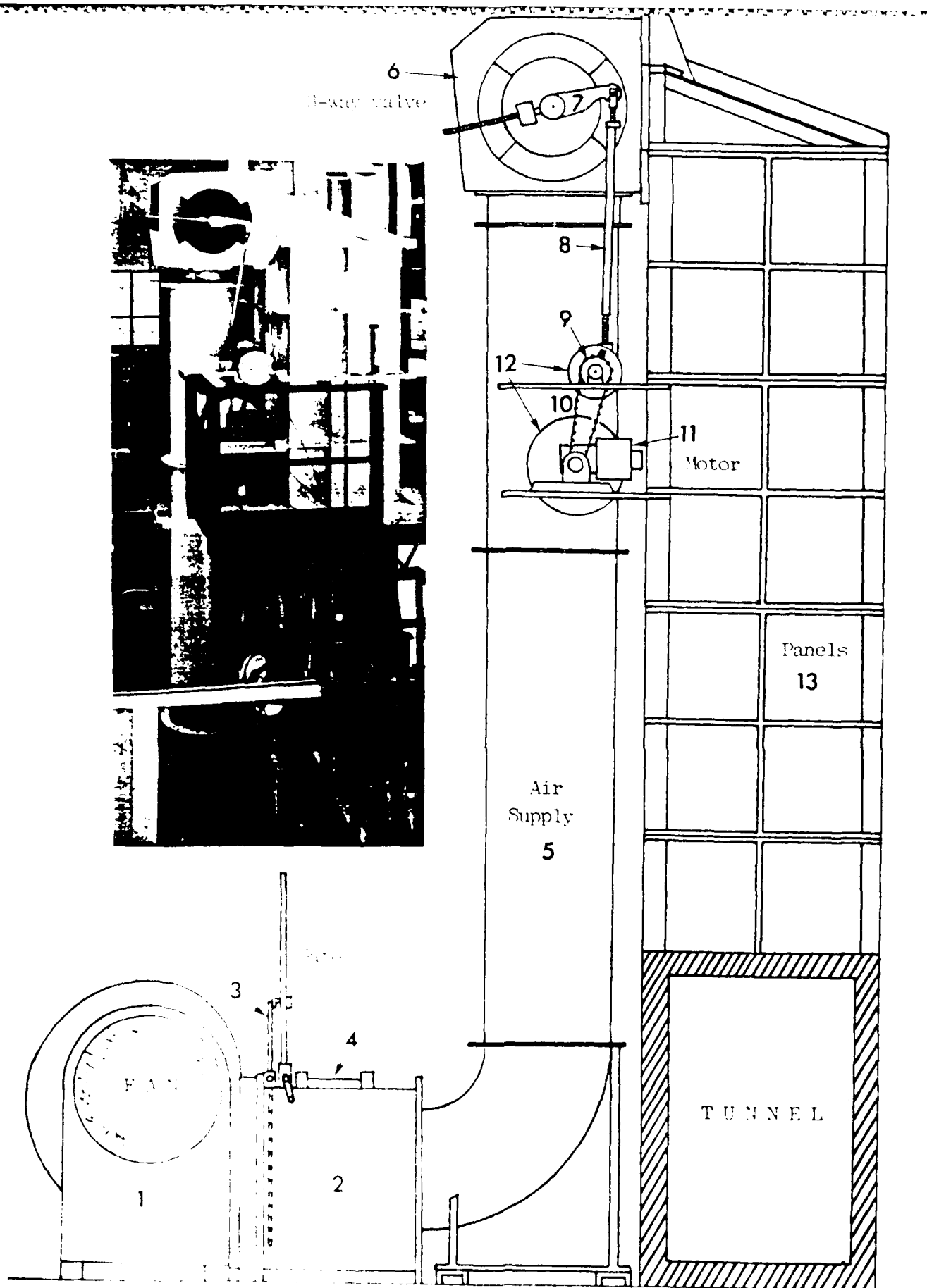

Fig. 5. Air supply system.

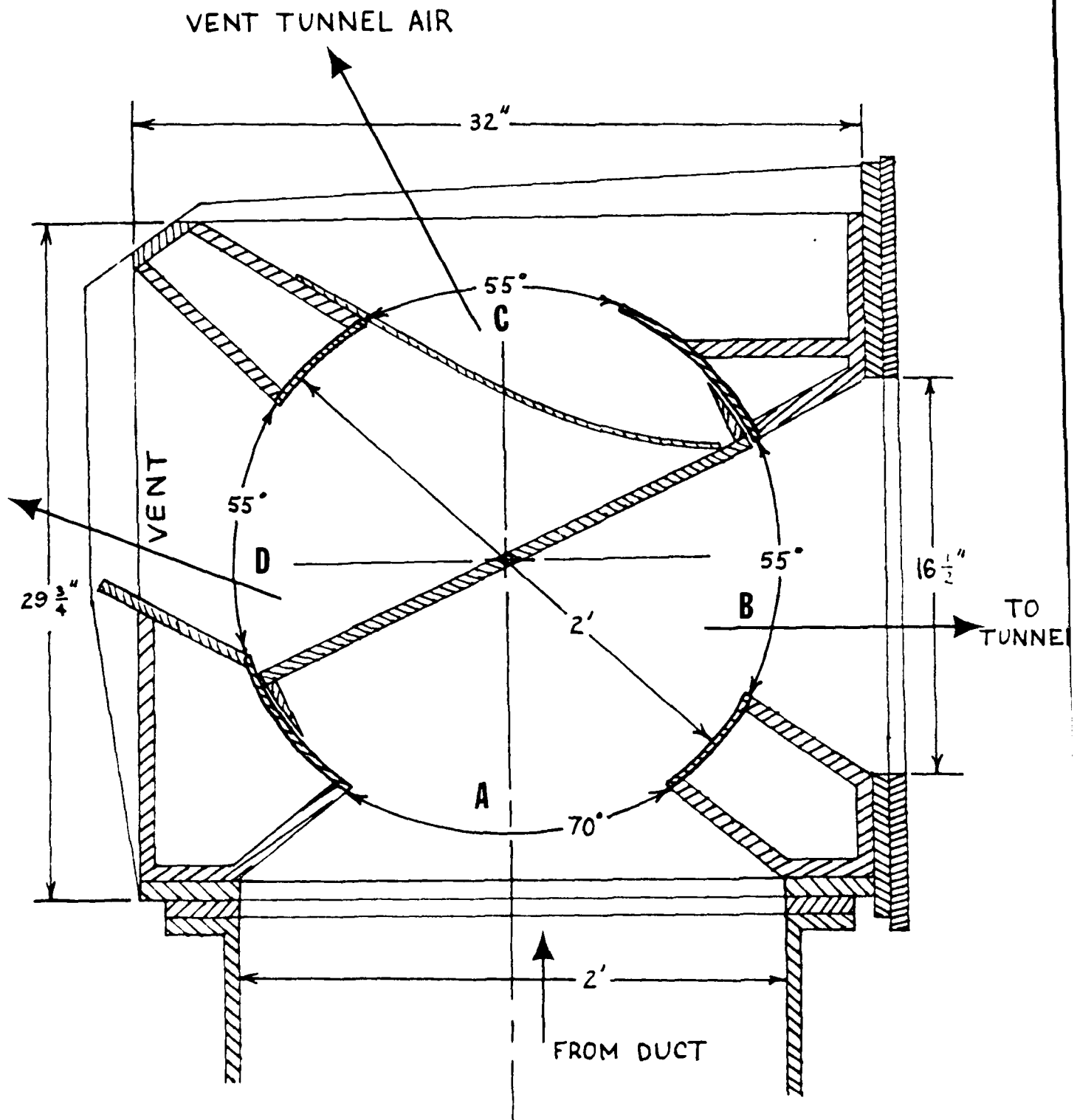

Fig. 4 Details of the three-way valve.

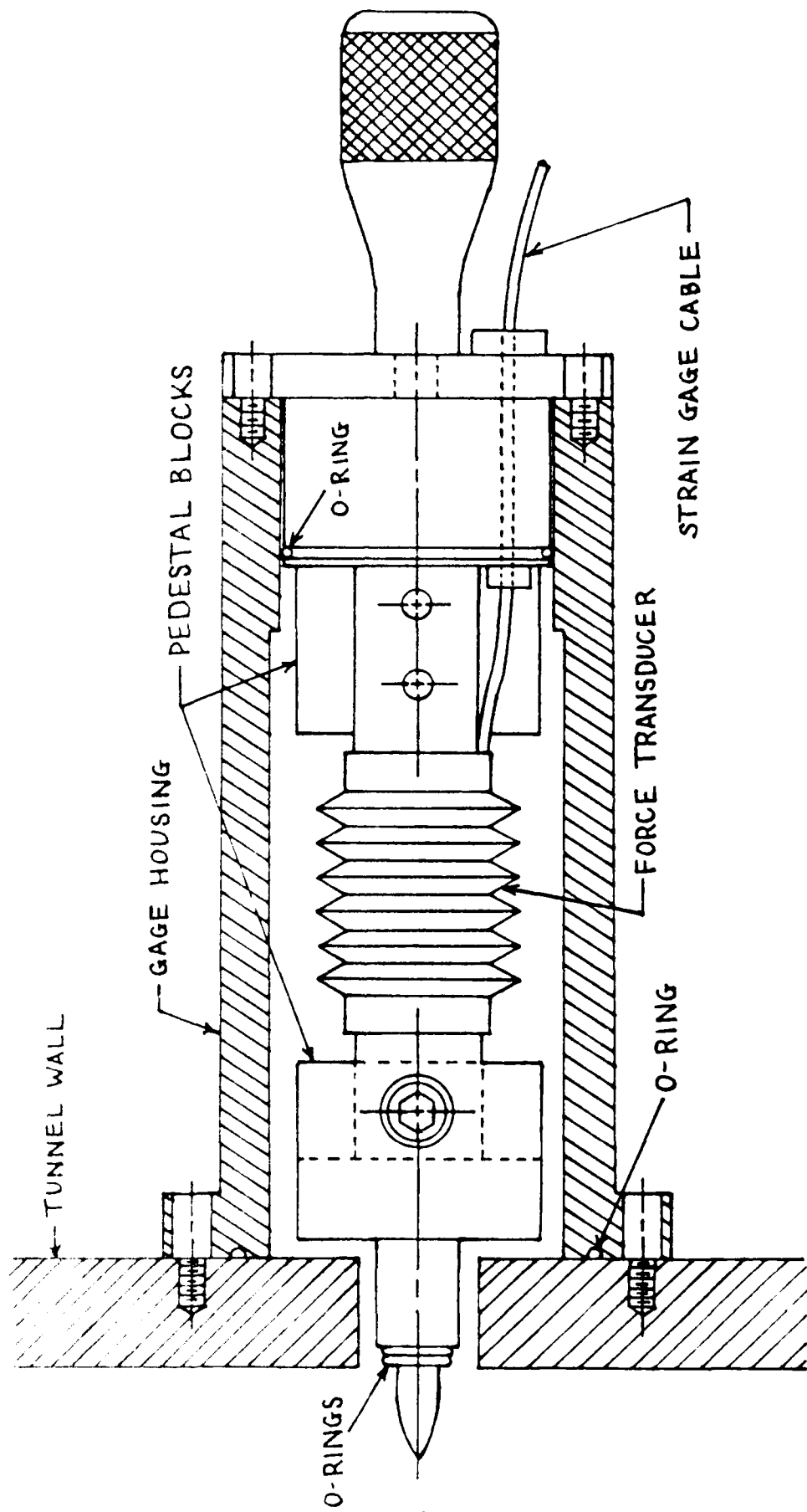

Fig. 5 Force transducer and its housing.

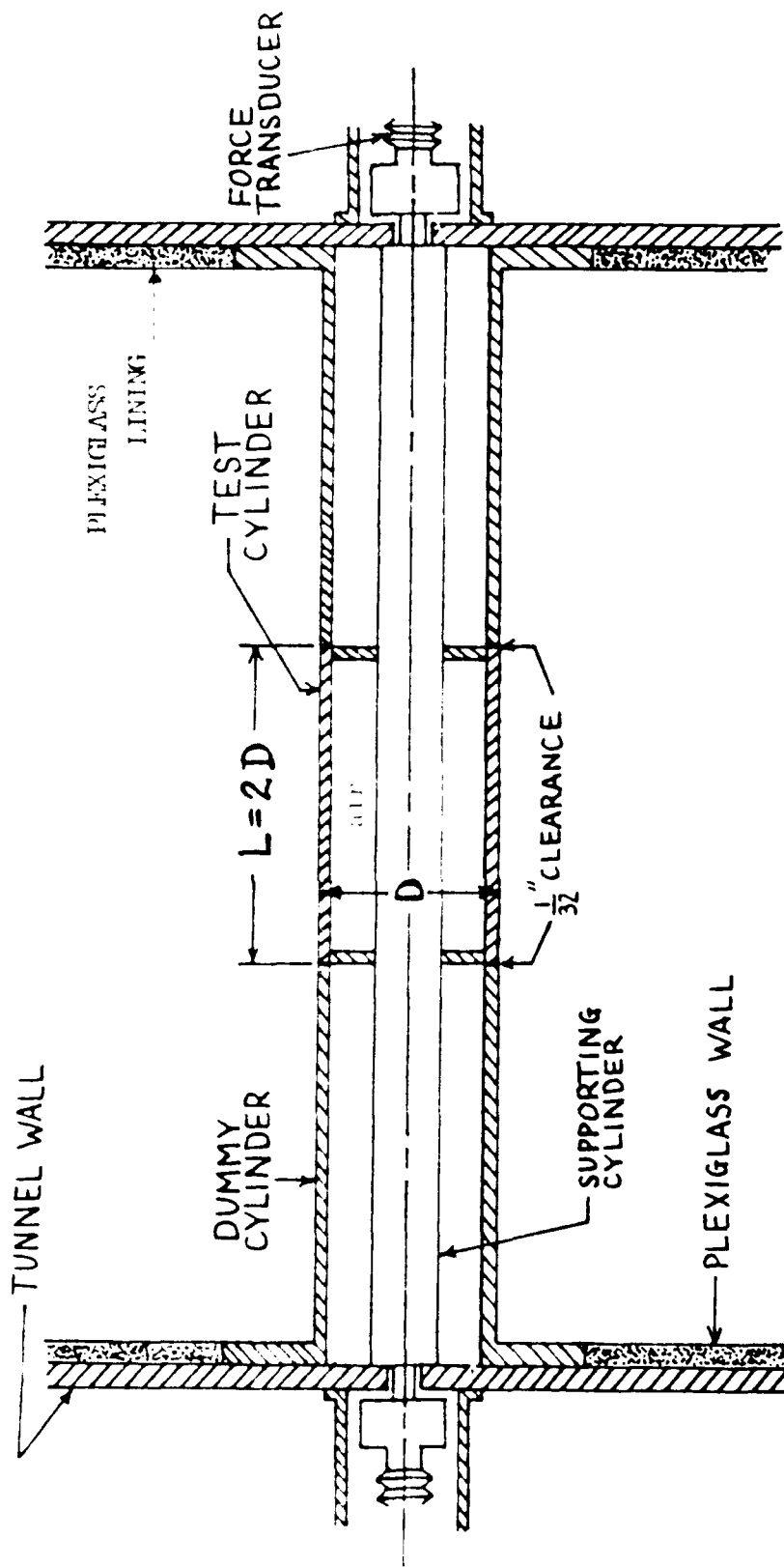

Fig. 6a Three-piece test cylinder.



Fig. 6b Three-piece smooth and rough cylinders.



Fig. 7 Marine-roughened cylinder  
Top: Position A; Bottom: Position B.

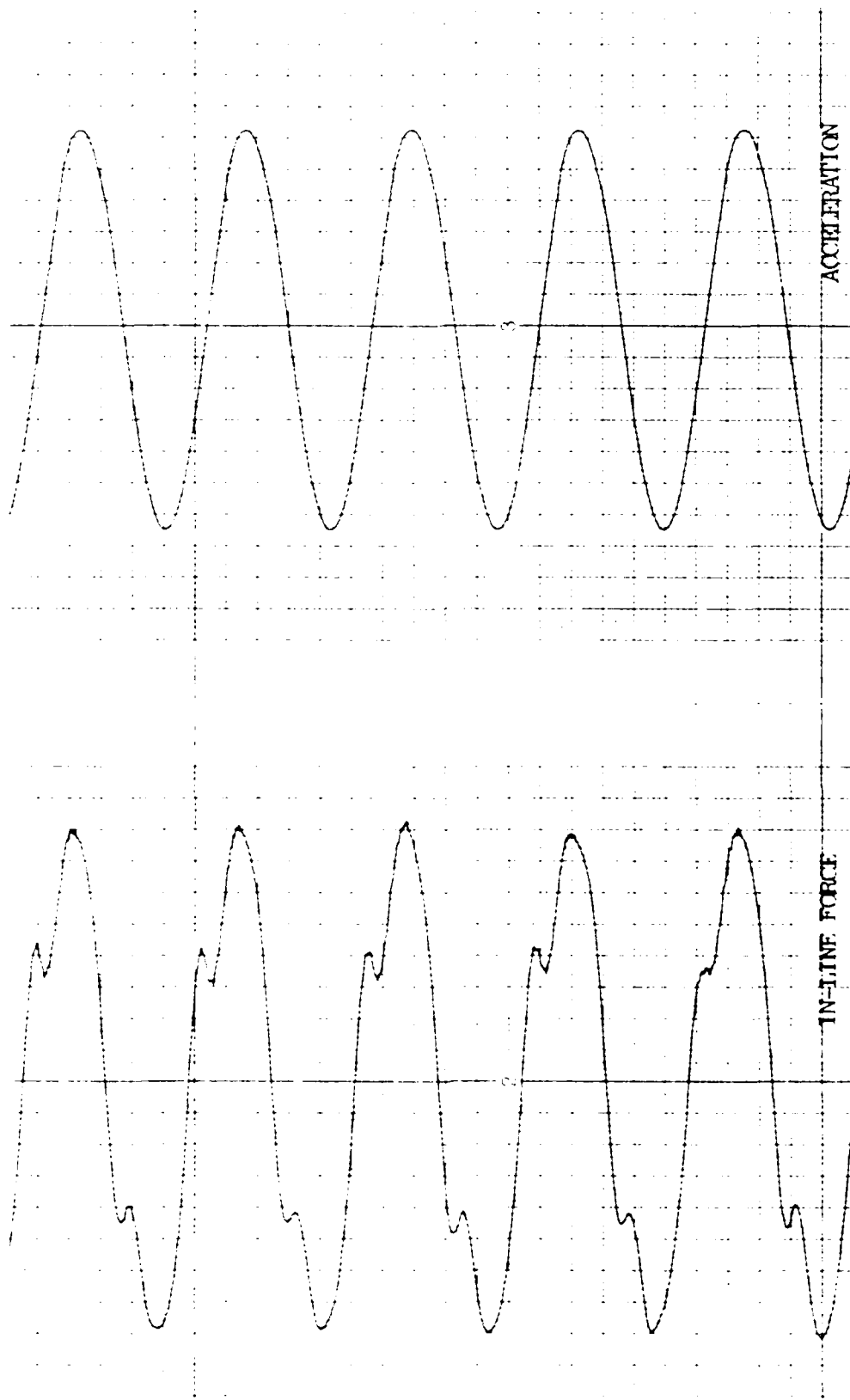

Fig. 8 Sample in-line force trace,  $K = 9.23$ ,  $k/D = 0$ ,  $\beta = 11,525$ .

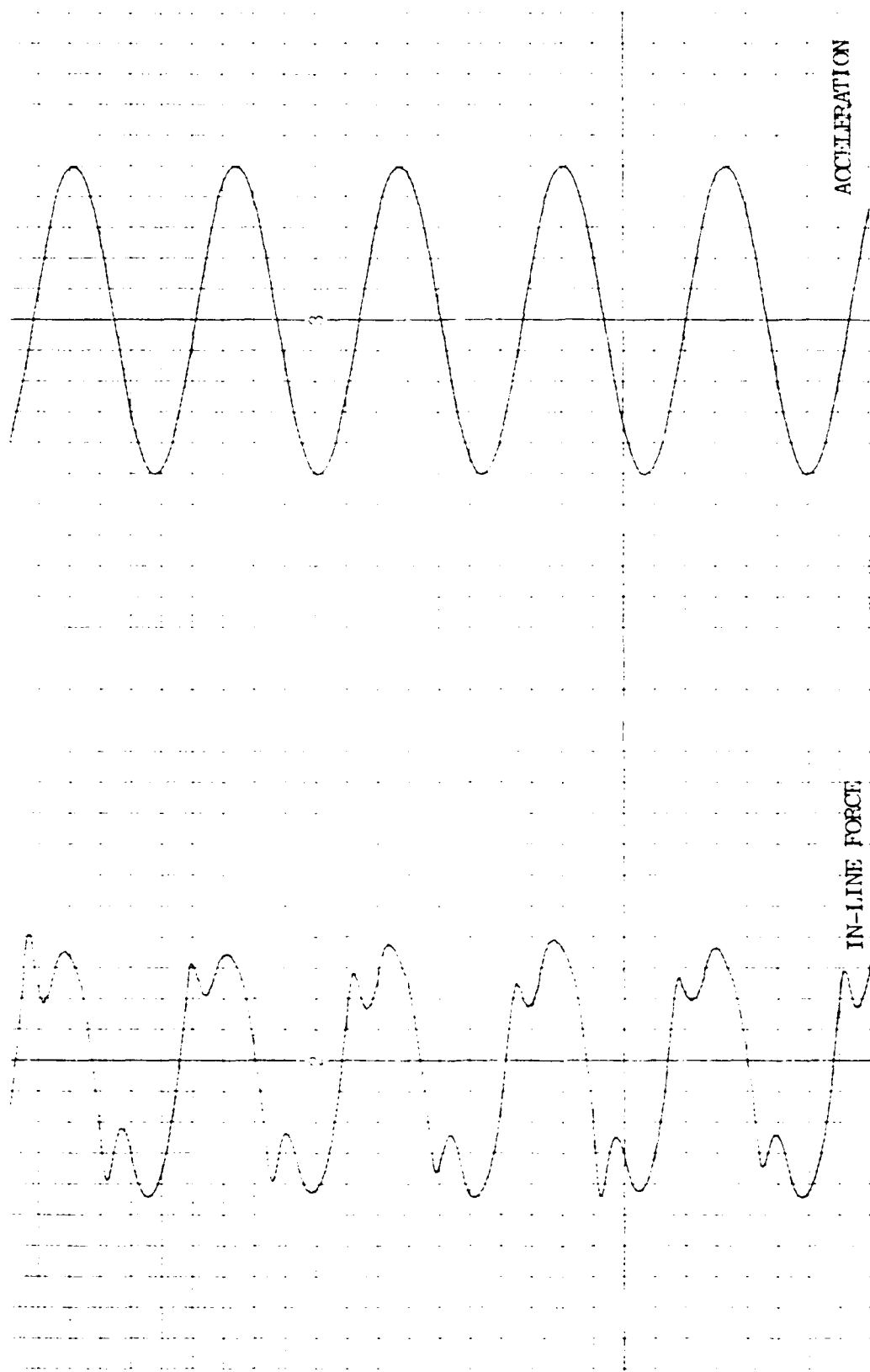

Fig. 9 Sample in-line force trace,  $K = 9.79$ ,  $k/D = 0$ ,  $\beta = 4720$ .

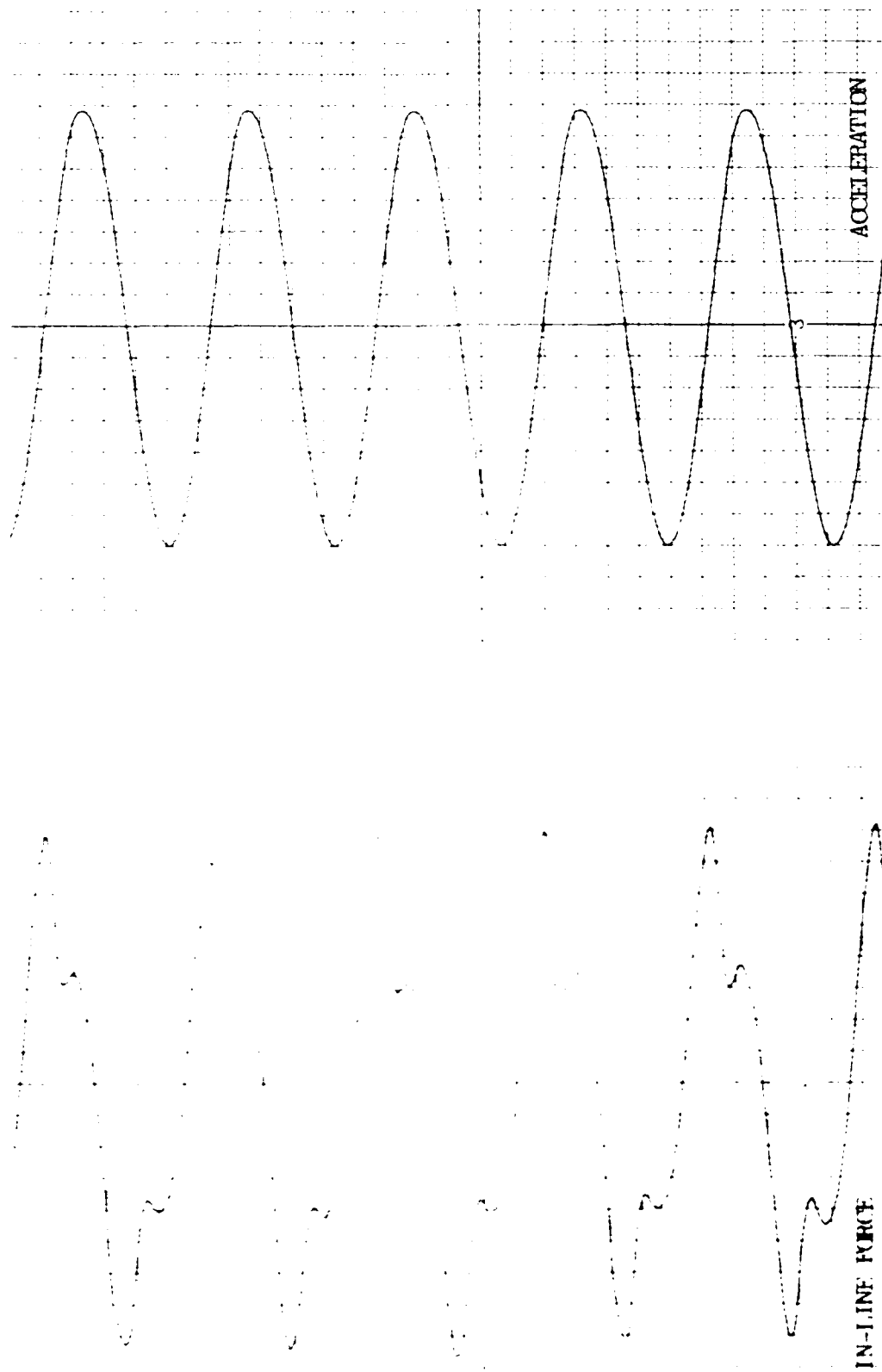

Fig. 10 Sample in-line force trace,  $K = 11.51$ ,  $k/D = 1/50$ ,  $\beta = 6836$ .

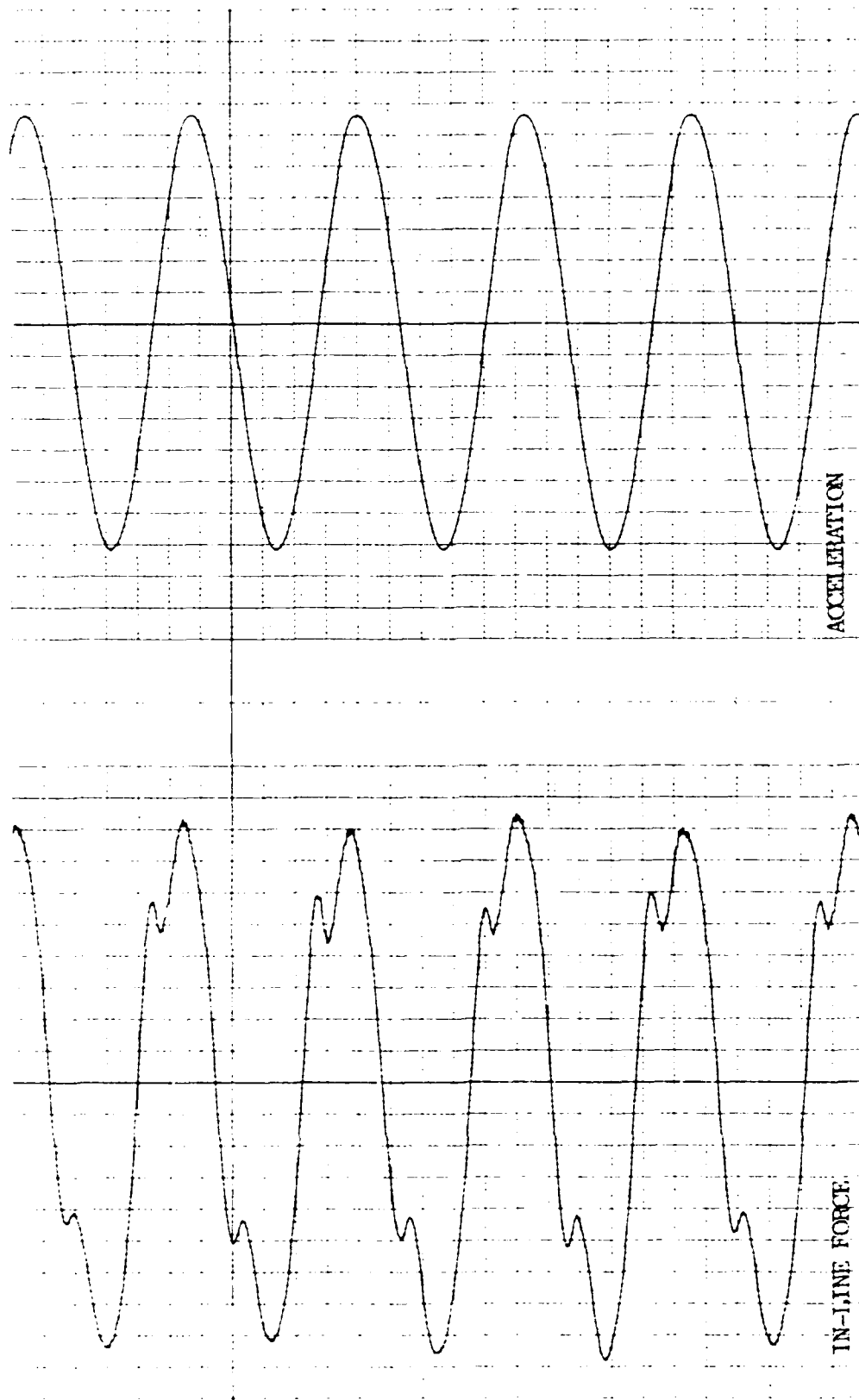

Fig. 11 Sample in-line force trace,  $K = 15.81$ ,  $k/D = 0$ ,  $\beta = 11,525$ .

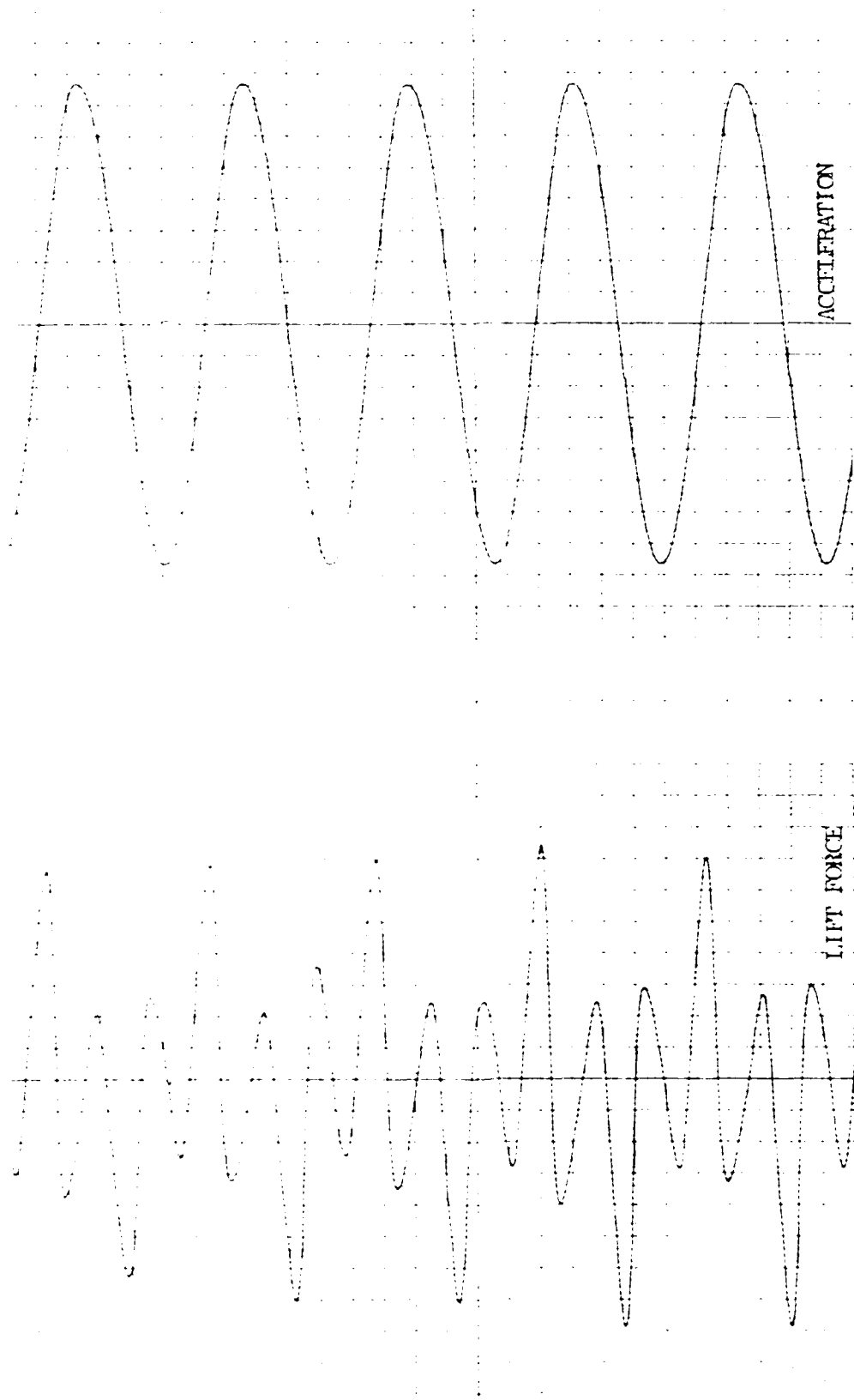

Fig. 12 Sample transverse force trace,  $K = 14.74$ ,  $k/D = 1/50$ ,  $\beta = 4924$ .

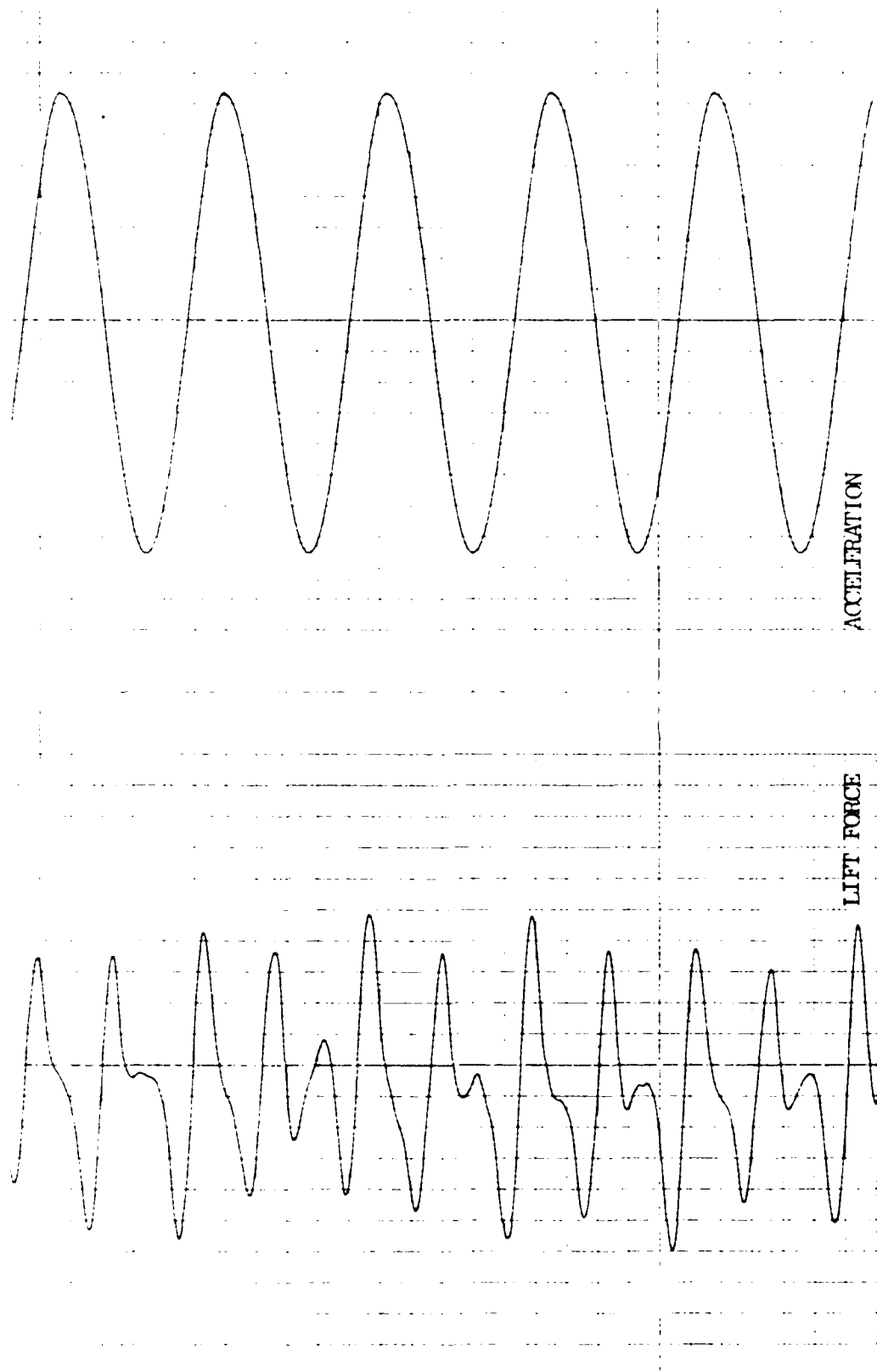

Fig. 13 Sample transverse force trace,  $K = 17.48$ ,  $k/D = 0$ ,  $\beta = 3435$ .

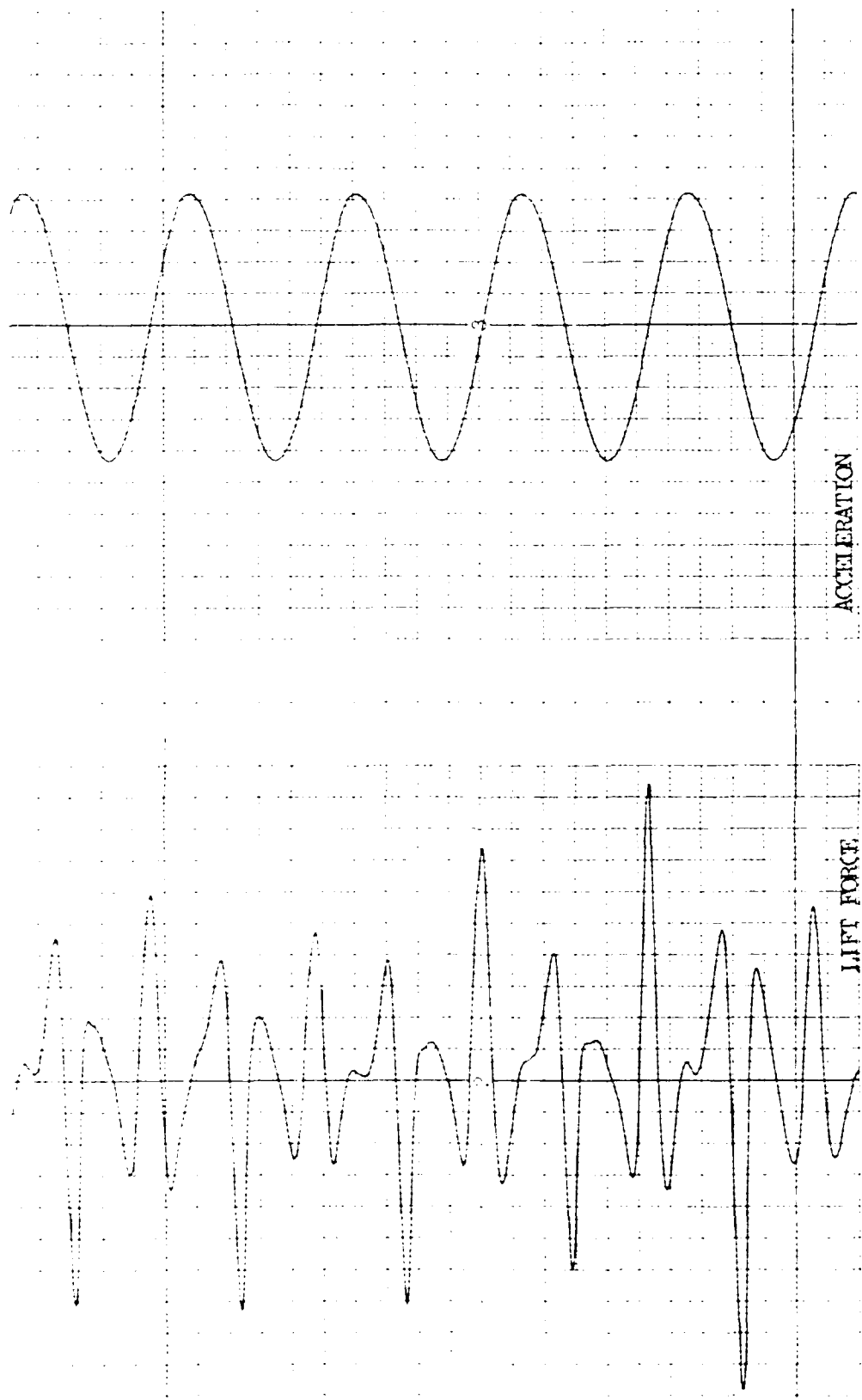

Fig. 14 Sample transverse force trace,  $K = 17.62$ ,  $k/D = 1/50$ ,  $\beta = 4924$ .

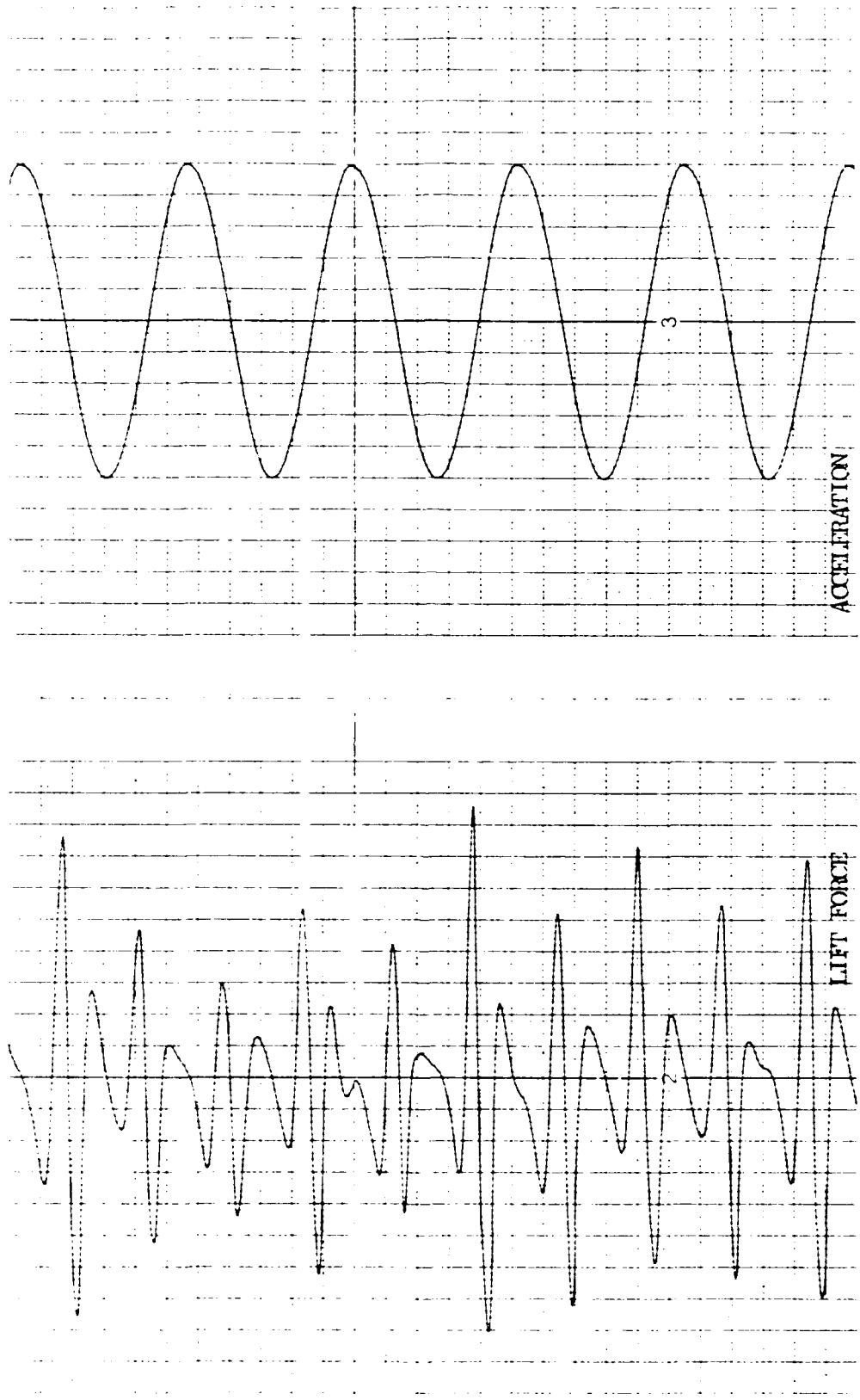

Fig. 15 Sample transverse force trace,  $K = 24.12$ ,  $k/D = 1/50$ ,  $\beta = 4924$ .

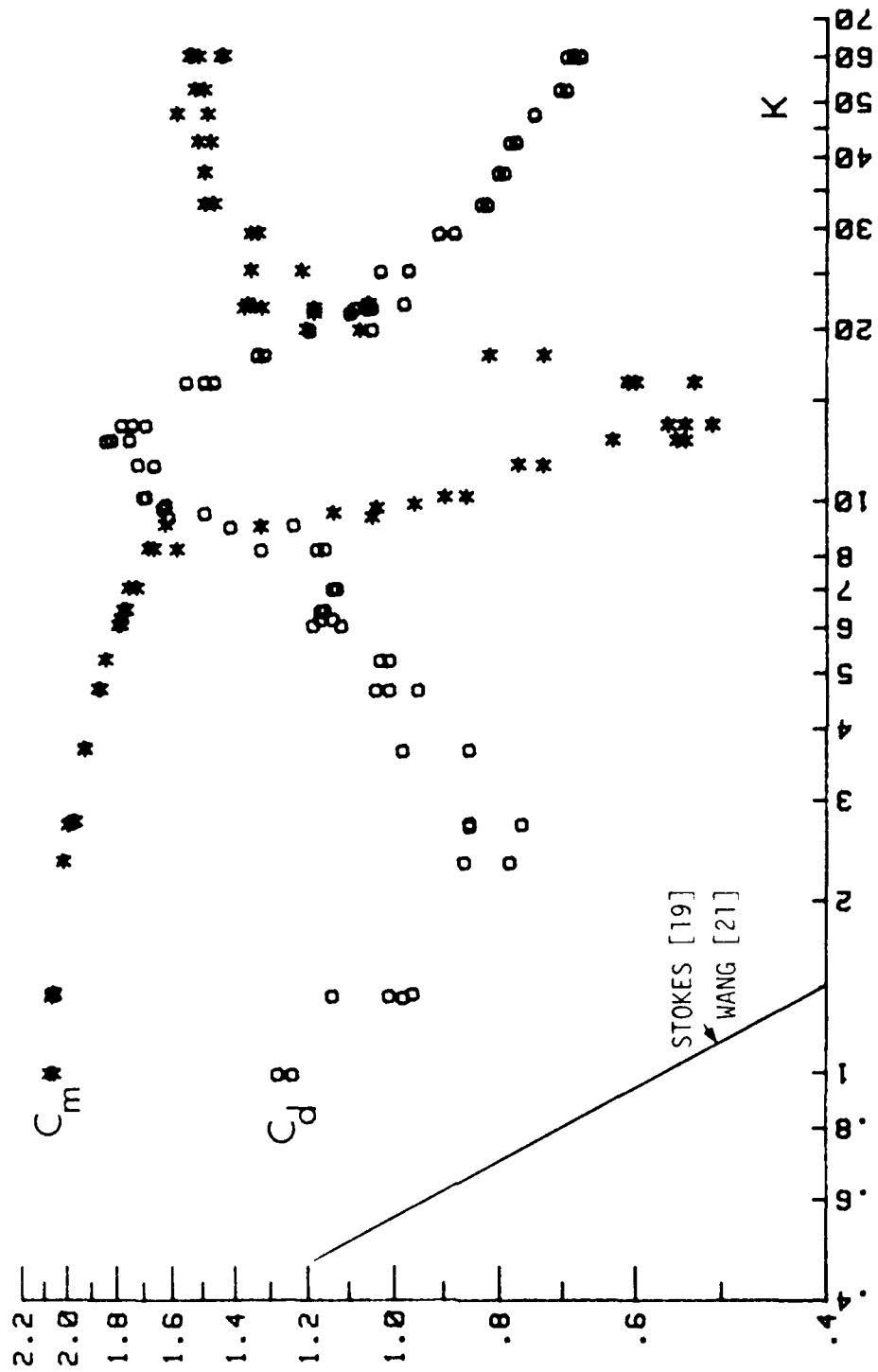

Fig. 16 Drag and inertia coefficients for a smooth cylinder as a function of K.

$\beta = 2300.$

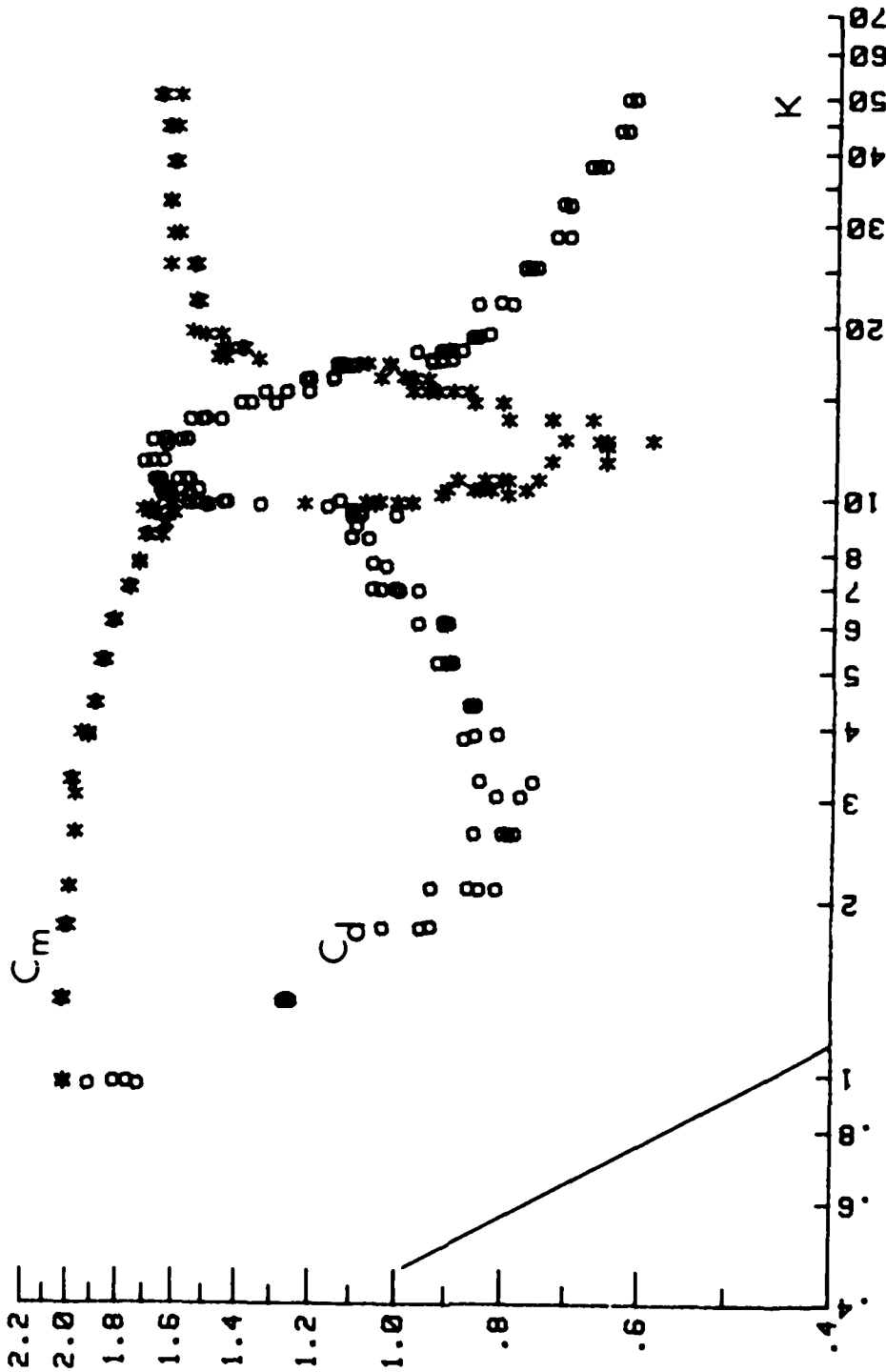

Fig. 17 Drag and inertia coefficients for a smooth cylinder as a function of  $K$ ,  
 $\beta = 3435$ .

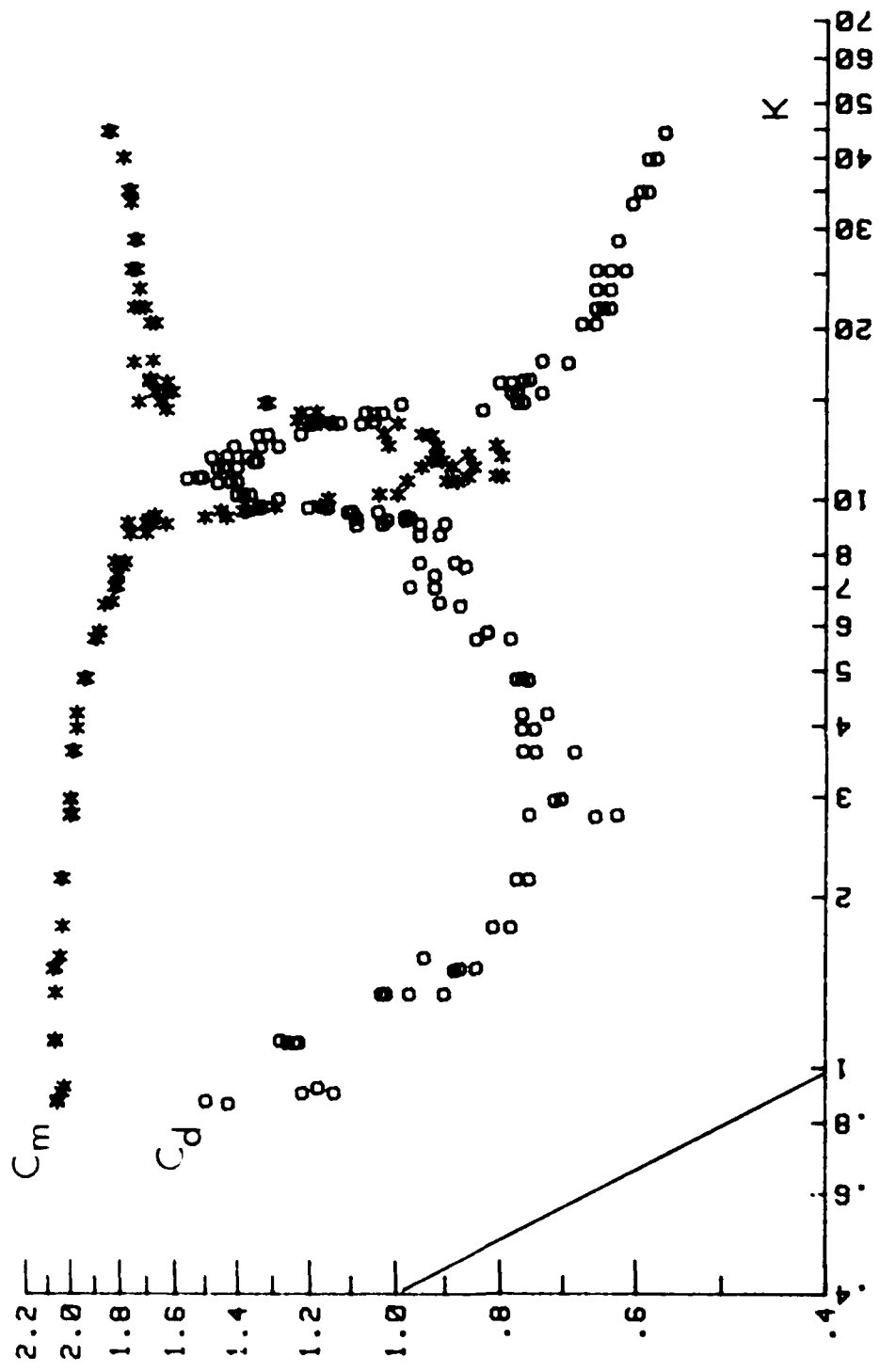

Fig. 18 Drag and inertia coefficients for a smooth cylinder as function of  $K$ ,  
 $\beta = 4720$ .

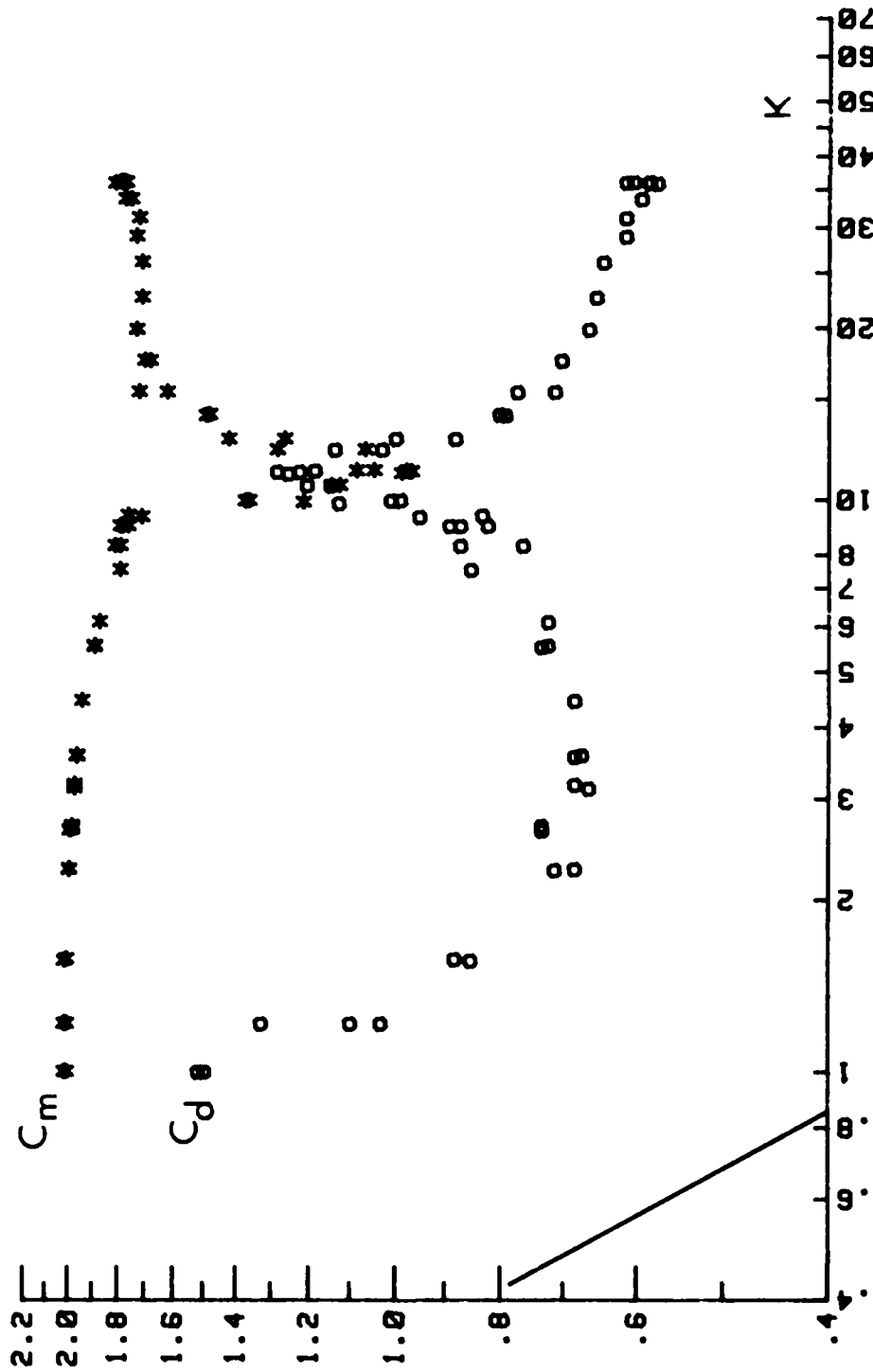

Fig. 19 Drag and inertia coefficients for a smooth cylinder as a function of  $K$ .  
 $\beta = 6555$ .

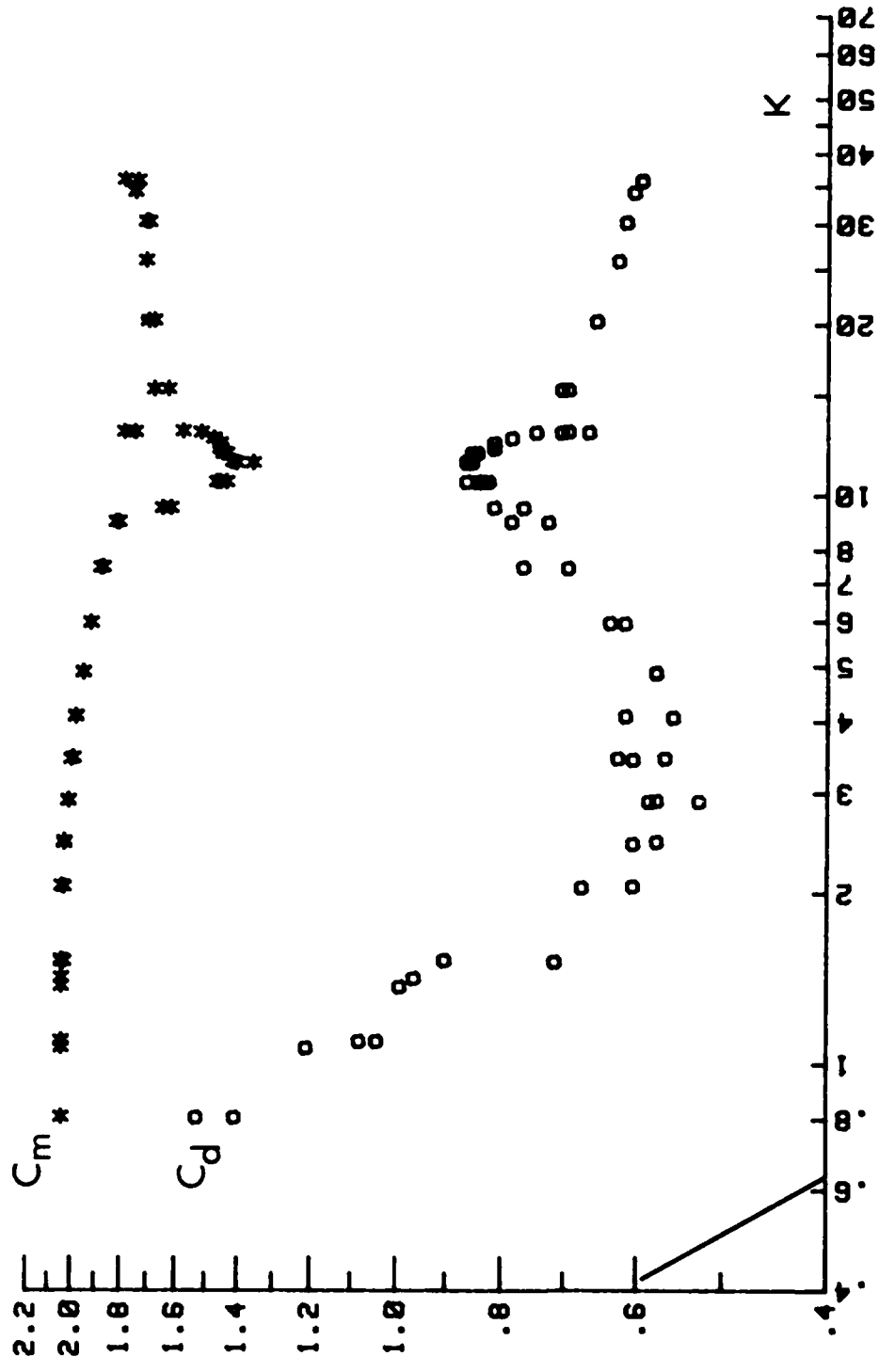

Fig. 20 Drag and inertia coefficients for a smooth cylinder as a function of K,  $\beta = 11525$ .

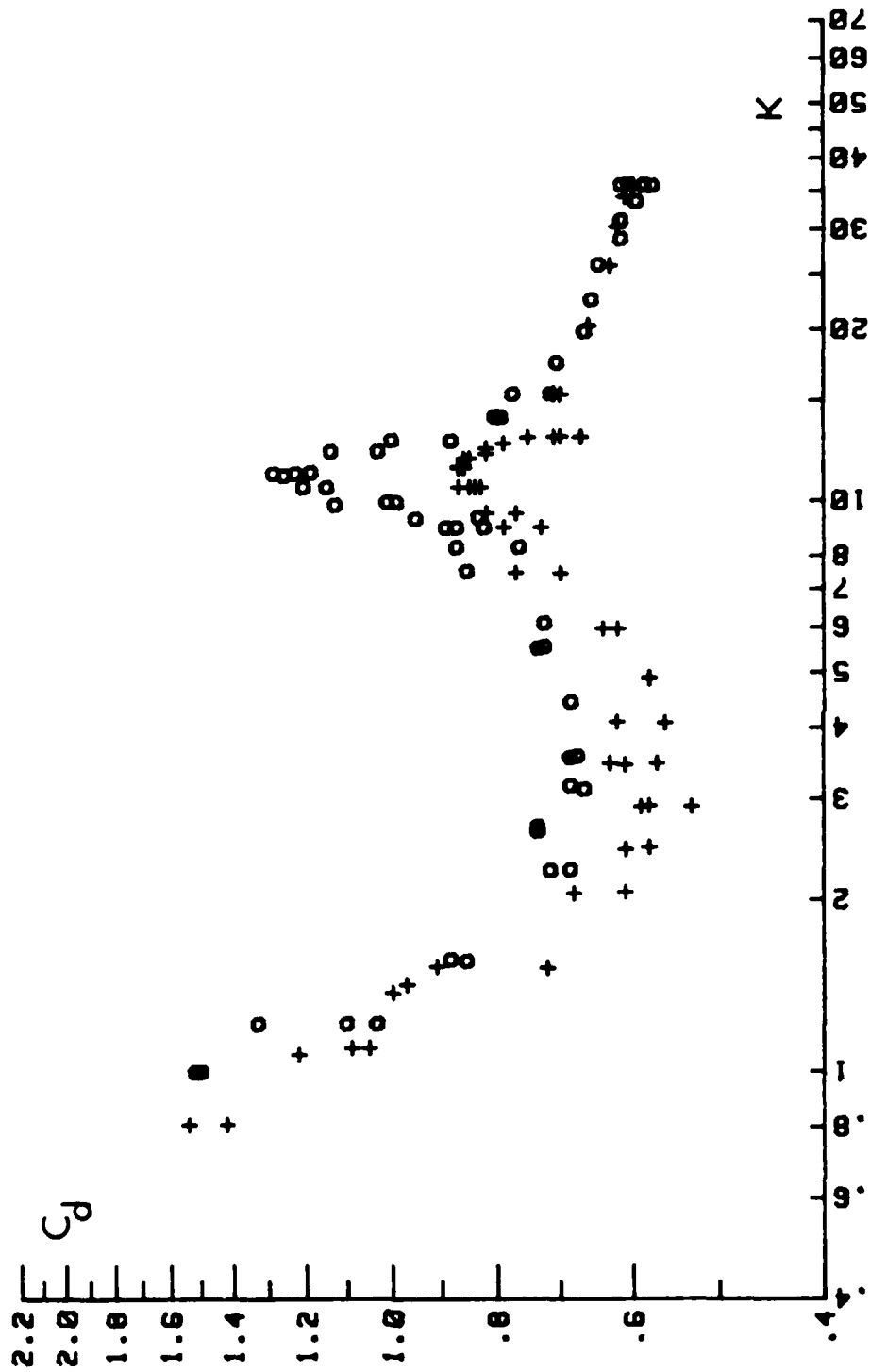

Fig. 21 Drag coefficient for two smooth cylinders as a function of  $K$ ,

$\circ$ ,  $\beta = 6555$ ;  $+$ ,  $\beta = 11525$ .

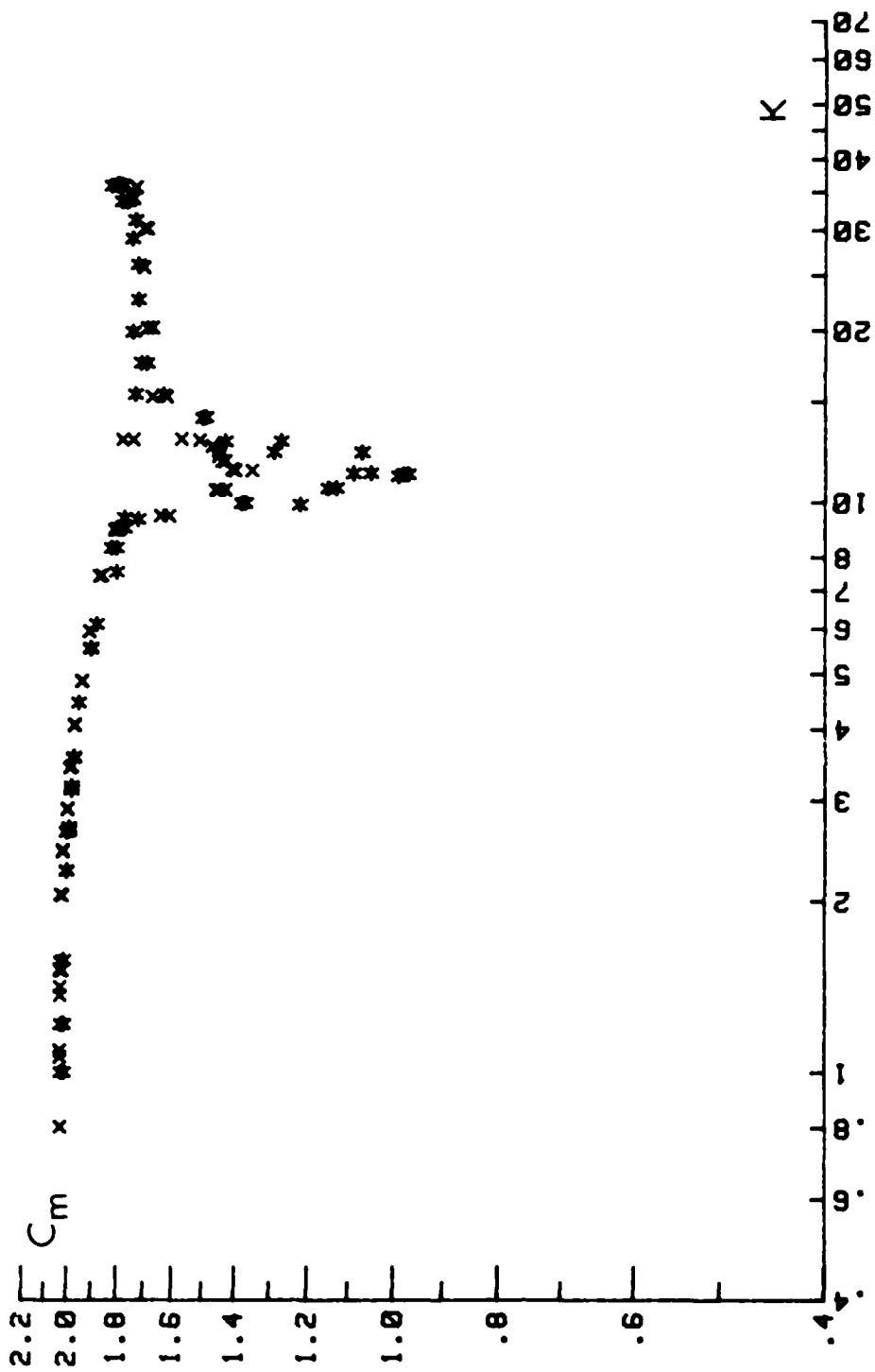

Fig. 22 Inertia coefficient for two smooth cylinders as a function of  $K$ ,

\*,  $\beta = 6555$ ; x,  $\beta = 11525$ .

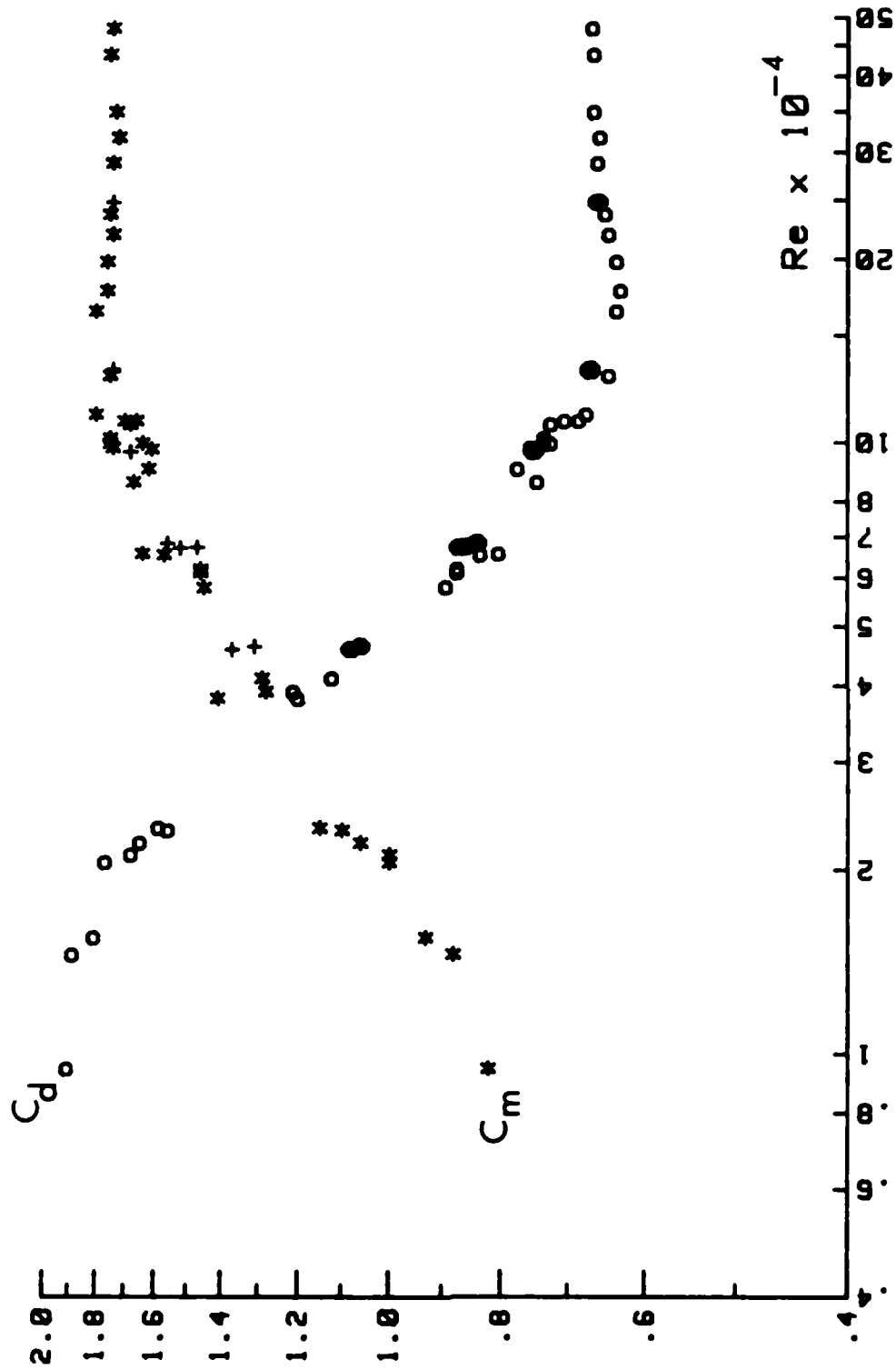

Fig. 23 Comparison of the present data with those reported in 1976 [1,2] for  $K = 20$ ,

● and +: Present data; ○ and #: 1976 data.

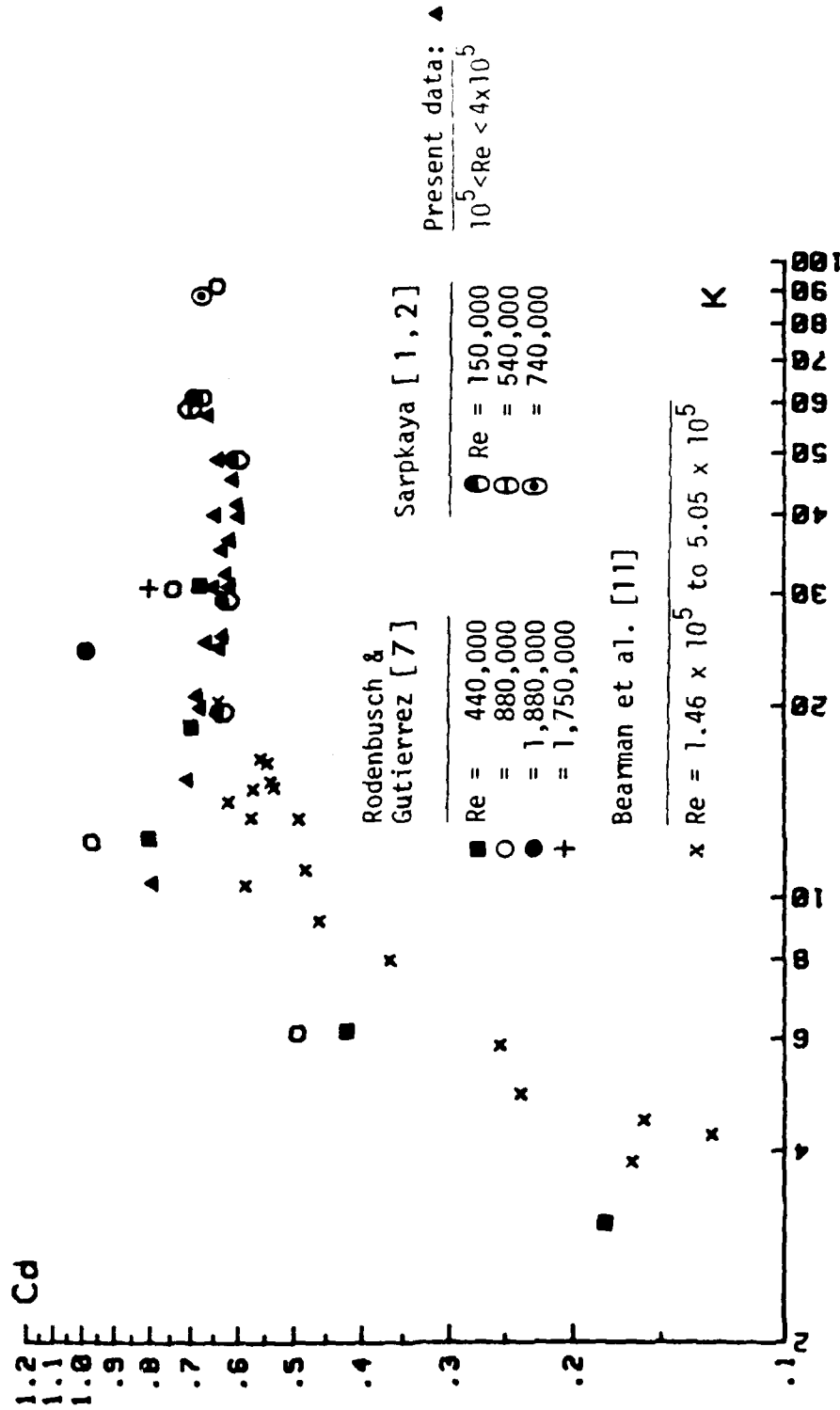

Fig. 24 Comparison of the present drag coefficients with those obtained by Sarpkaya [1,2], Rodenbusch & Gutierrez [7], and Bearman et al. [11].

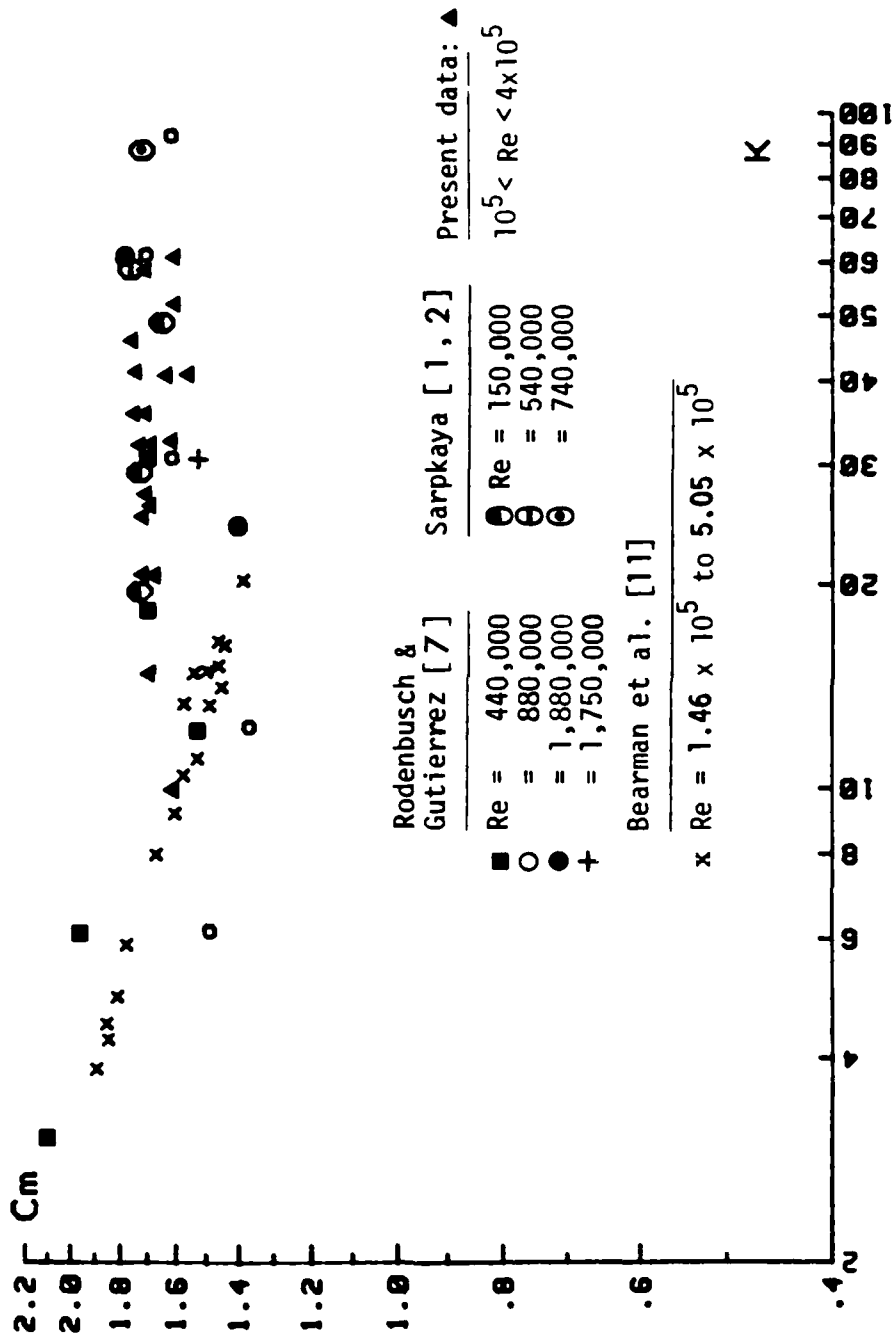

Fig. 25 Comparison of the present inertia coefficients with those obtained by Sarpkaya [1,2], Rodenbusch & Gutierrez [7], and Bearman et al. [11].

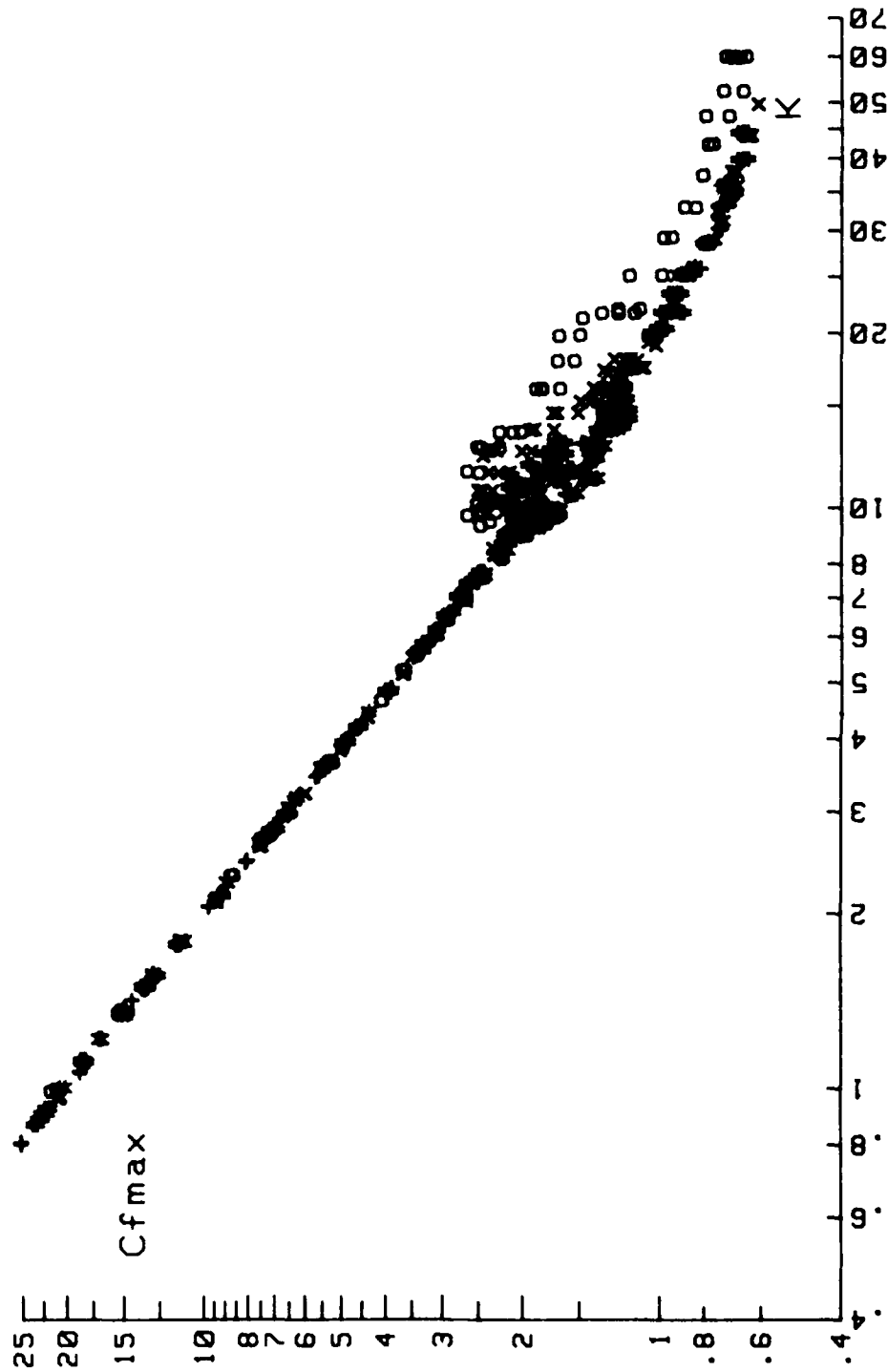

Fig. 26 Maximum force coefficient for smooth cylinders as a function of K.  
 o.  $\beta = 2300$ ; x,  $\beta = 3435$ ; #,  $\beta = 4720$ ; \*,  $\beta = 6555$ ; +,  $\beta = 11525$ .

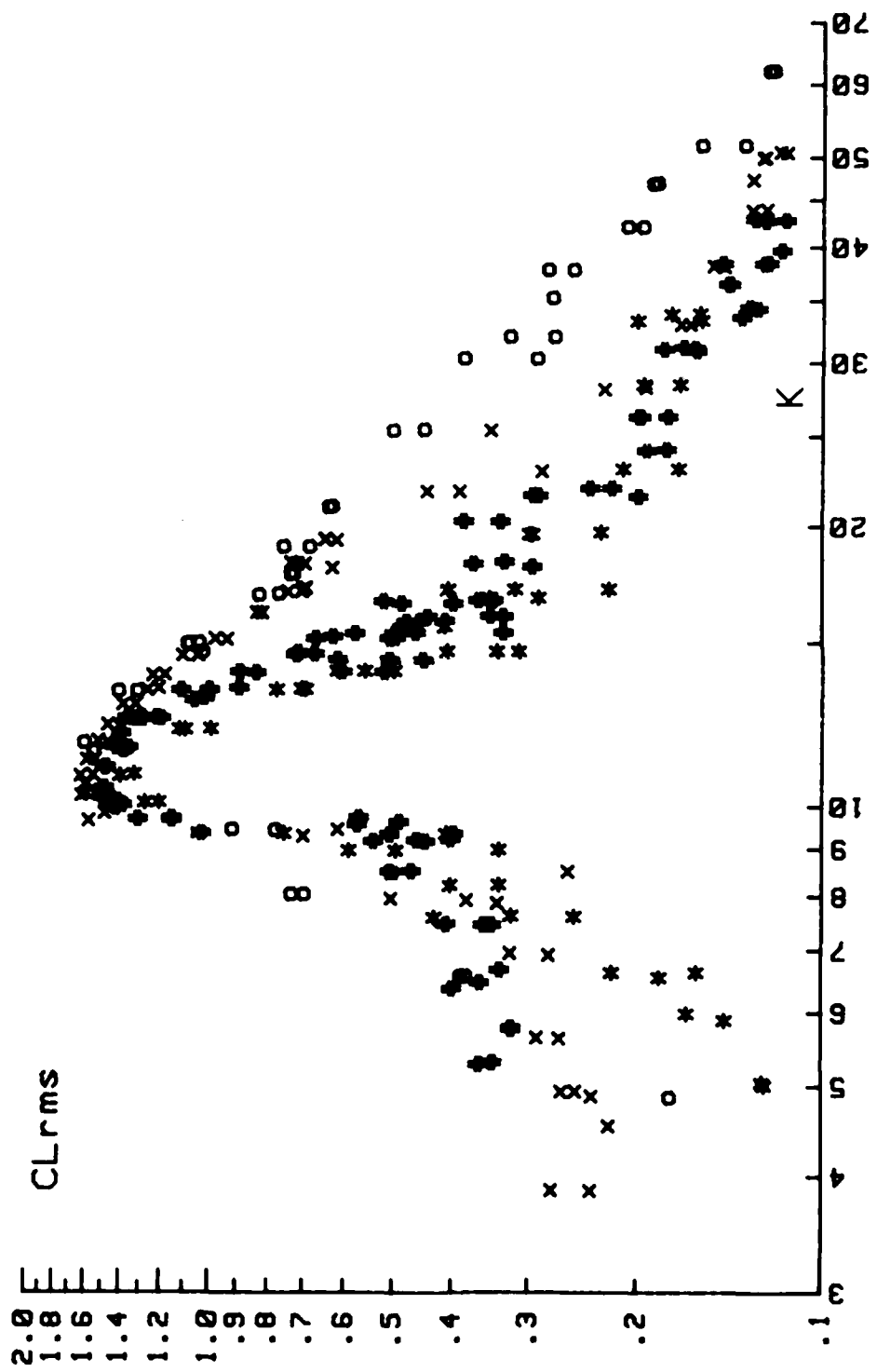

Fig. 27 RMS lift coefficient for smooth cylinders as a function of  $K$ .  
 o,  $\beta = 2300$ ; x,  $\beta = 3435$ ; #,  $\beta = 4720$ ; and \*,  $\beta = 6555$ .

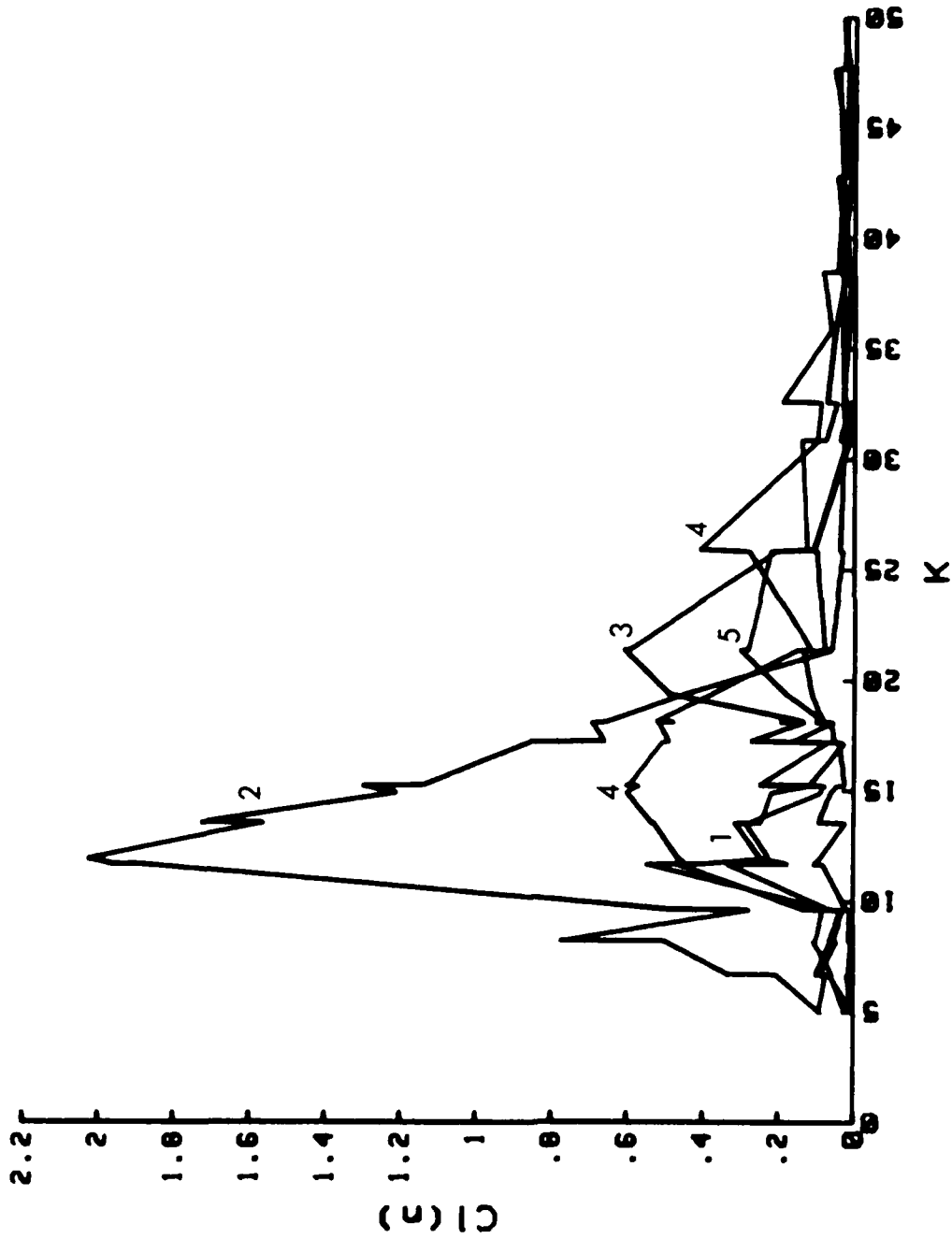

Fig. 28 Amplitude of the harmonics of the lift force for a smooth cylinder,  
 $\beta = 2300$ .

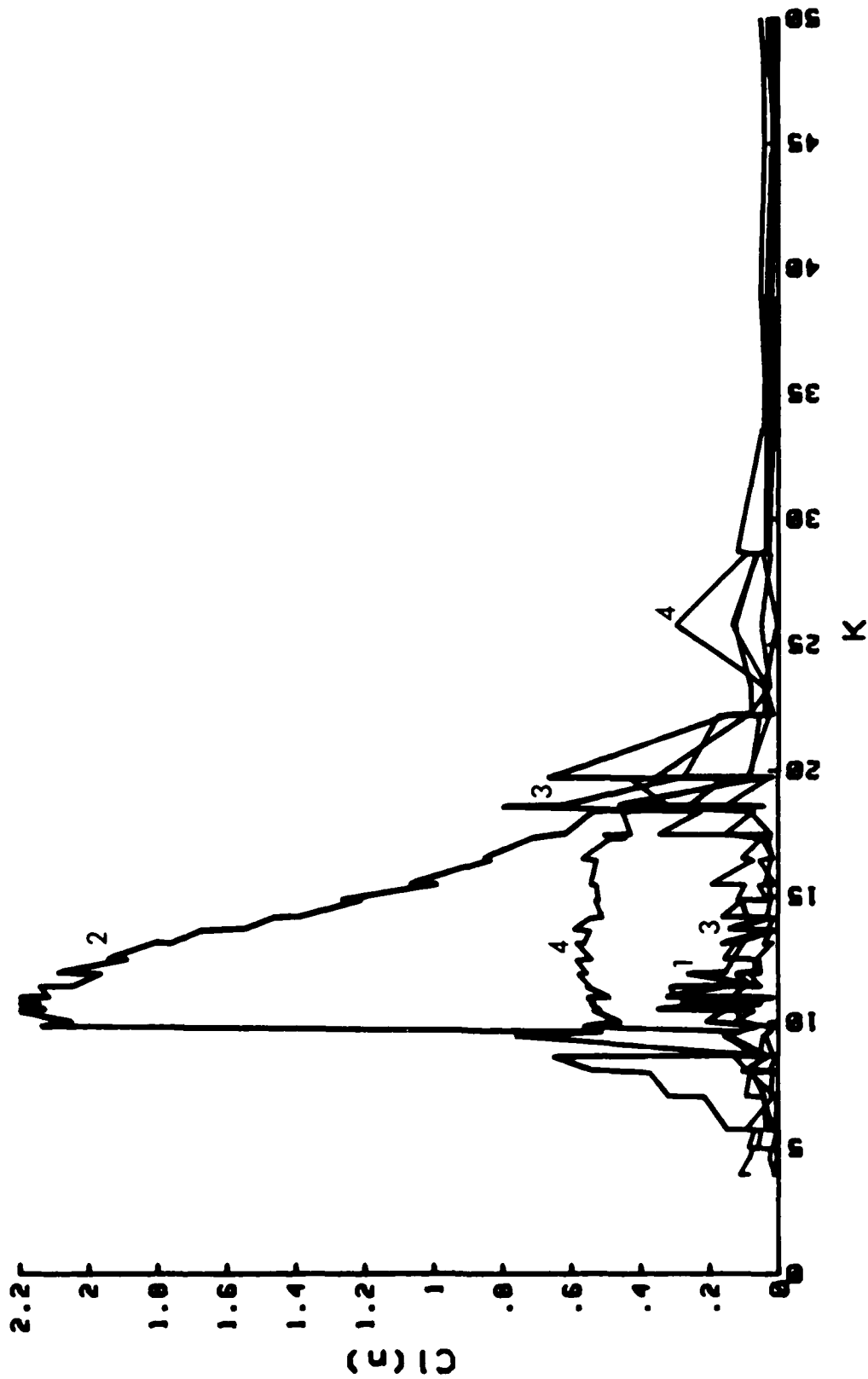

Fig. 29 Amplitude of the harmonics of the lift force for a smooth cylinder,  
 $\beta = 3435$ .

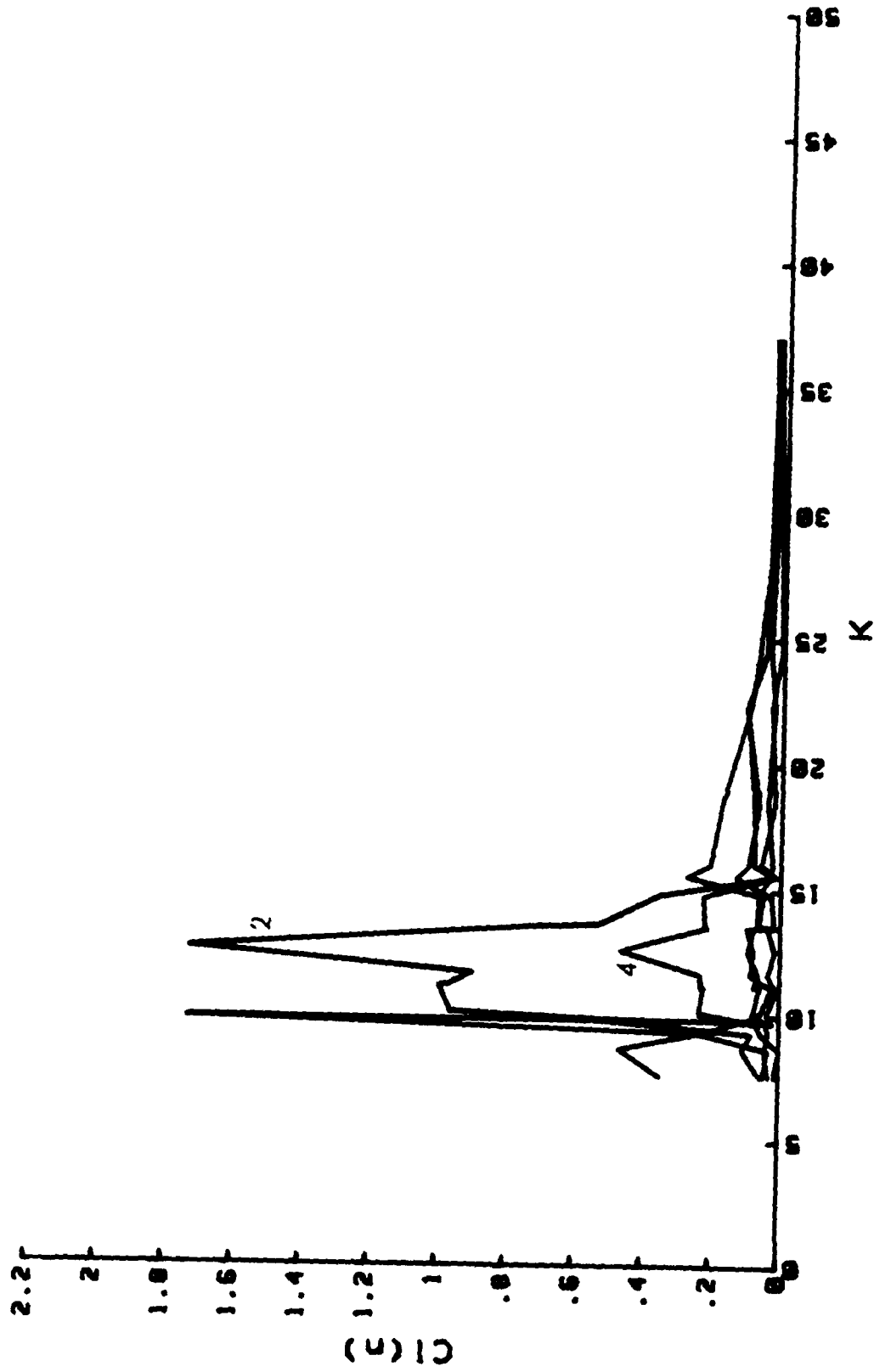

Fig. 30 Amplitude of the harmonics of the lift force for a smooth cylinder.  
 $\beta = 4720$ .

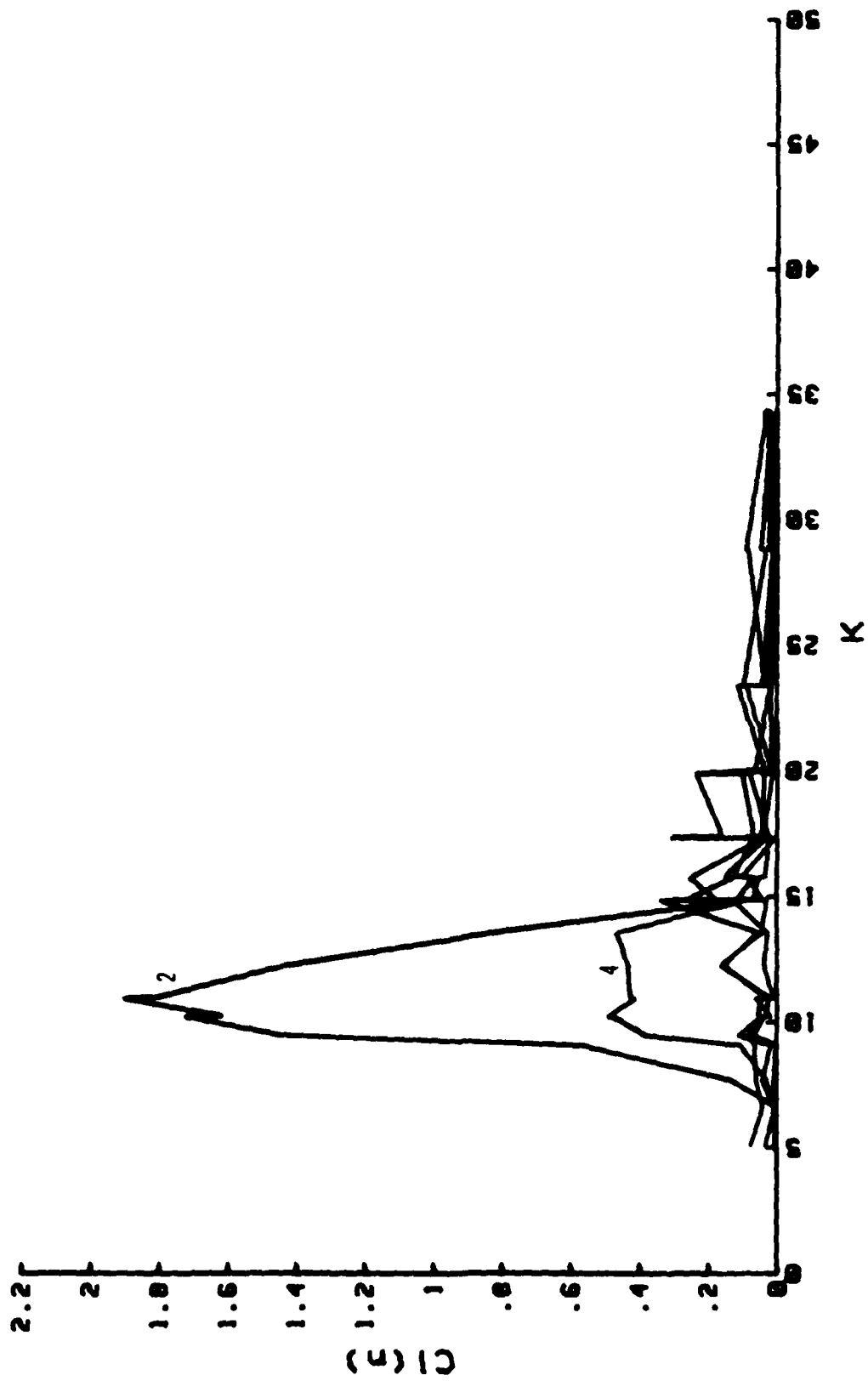

Fig. 31 Amplitude of the harmonics of the lift force for a smooth cylinder,  
 $\beta = 6555$ .

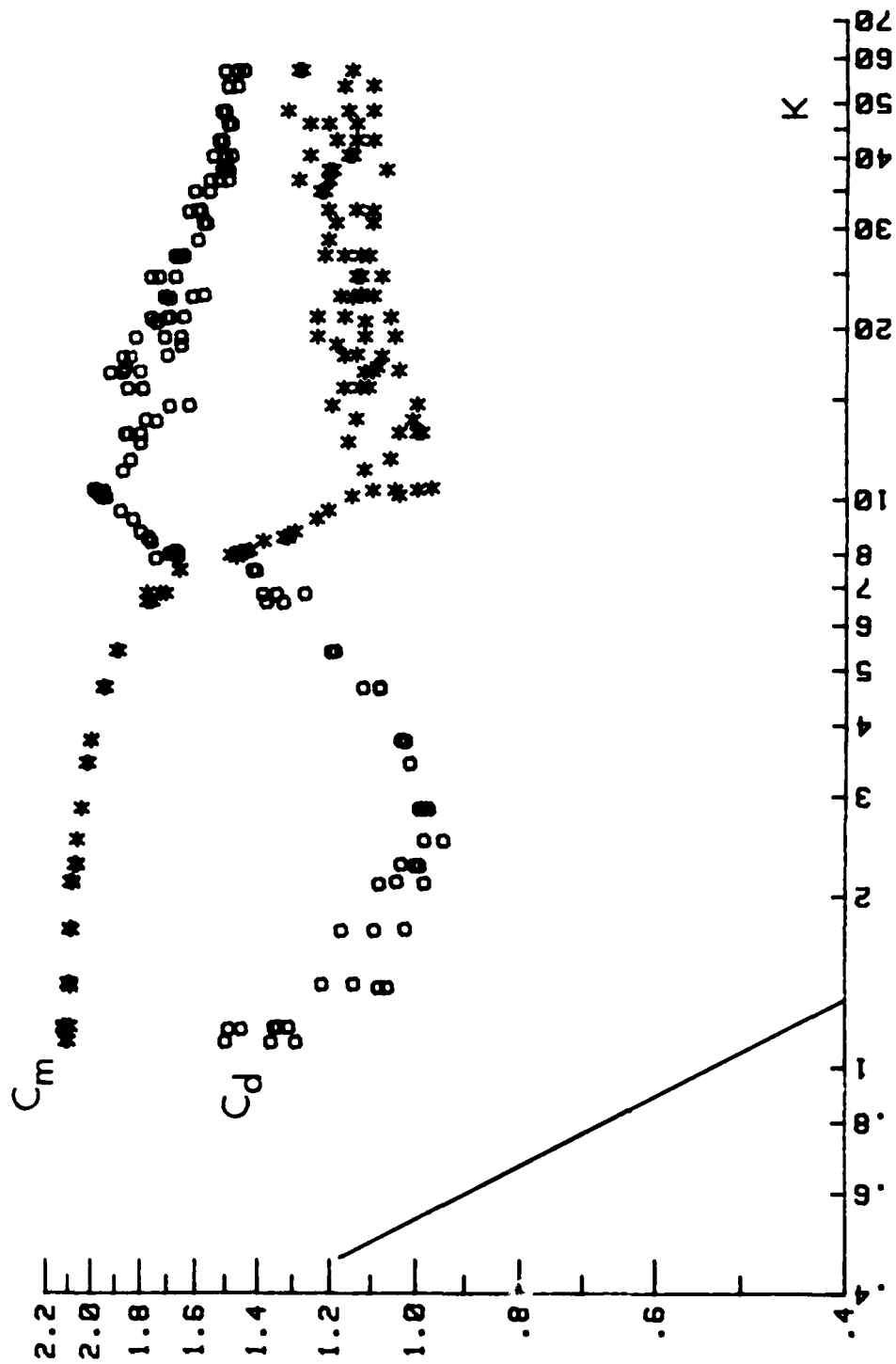

Fig. 32 Drag and inertia coefficients for a rough cylinder as a function of K,  
 $\beta = 2412, k/D = 1/50.$

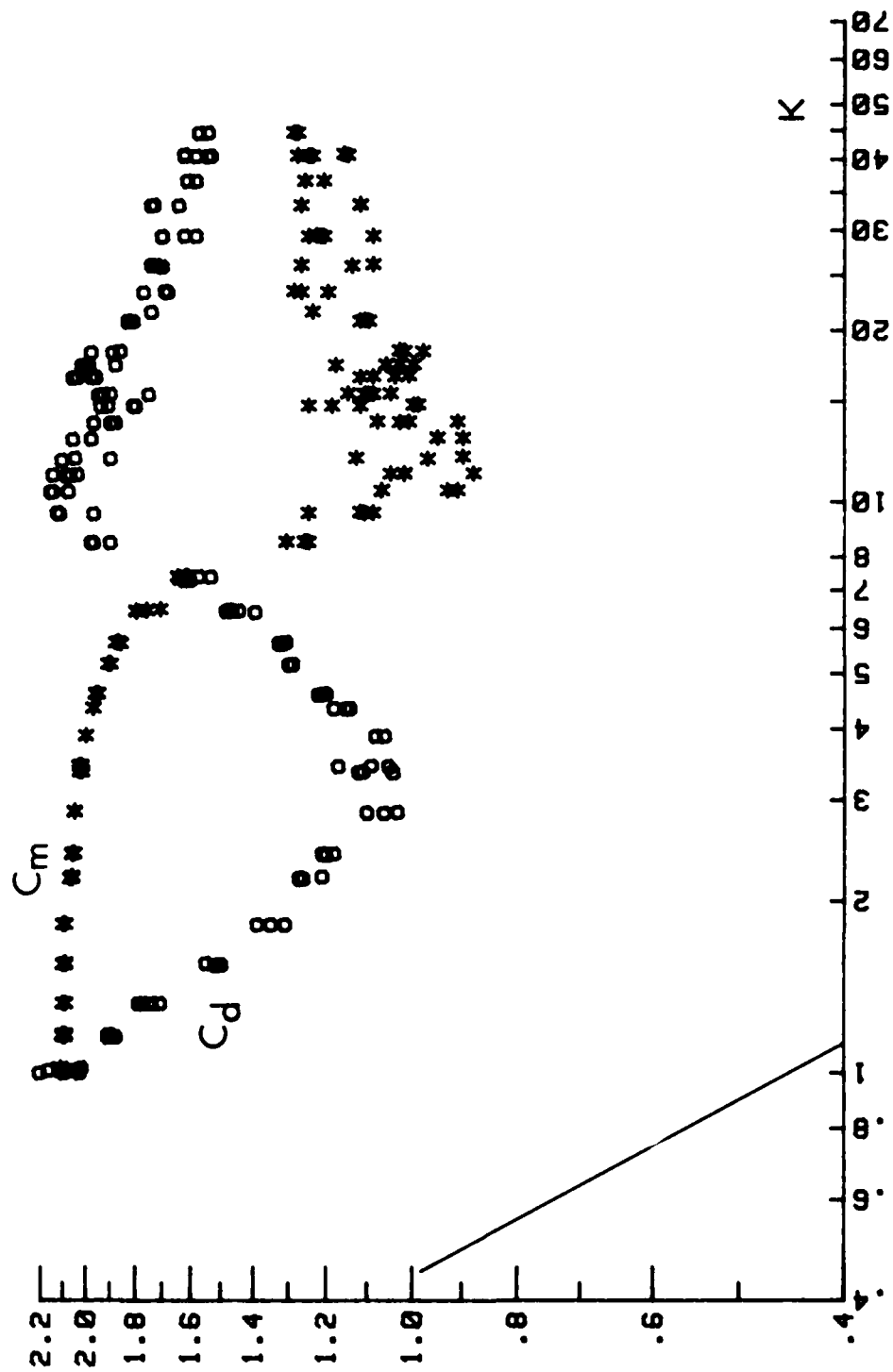

Fig. 33 Drag and inertia coefficients for a rough cylinder as a function of  $K$ .  
 $\beta = 3598$ ,  $k/D = 1/50$ .

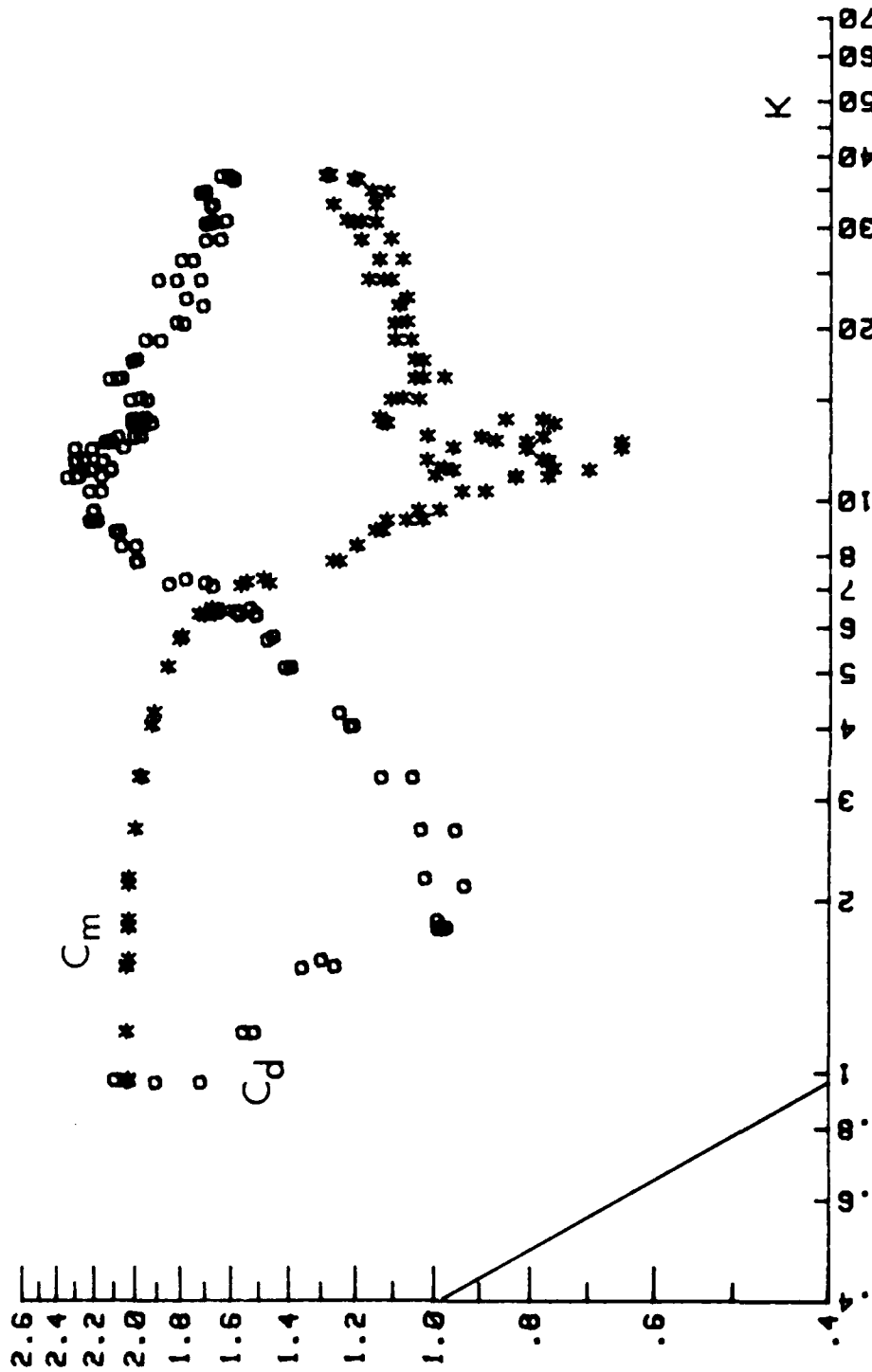

Fig. 34 Drag and inertia coefficients for a rough cylinder as a function of  $K$ ,  
 $\beta = 4924$ ,  $k/D = 1/50$ .

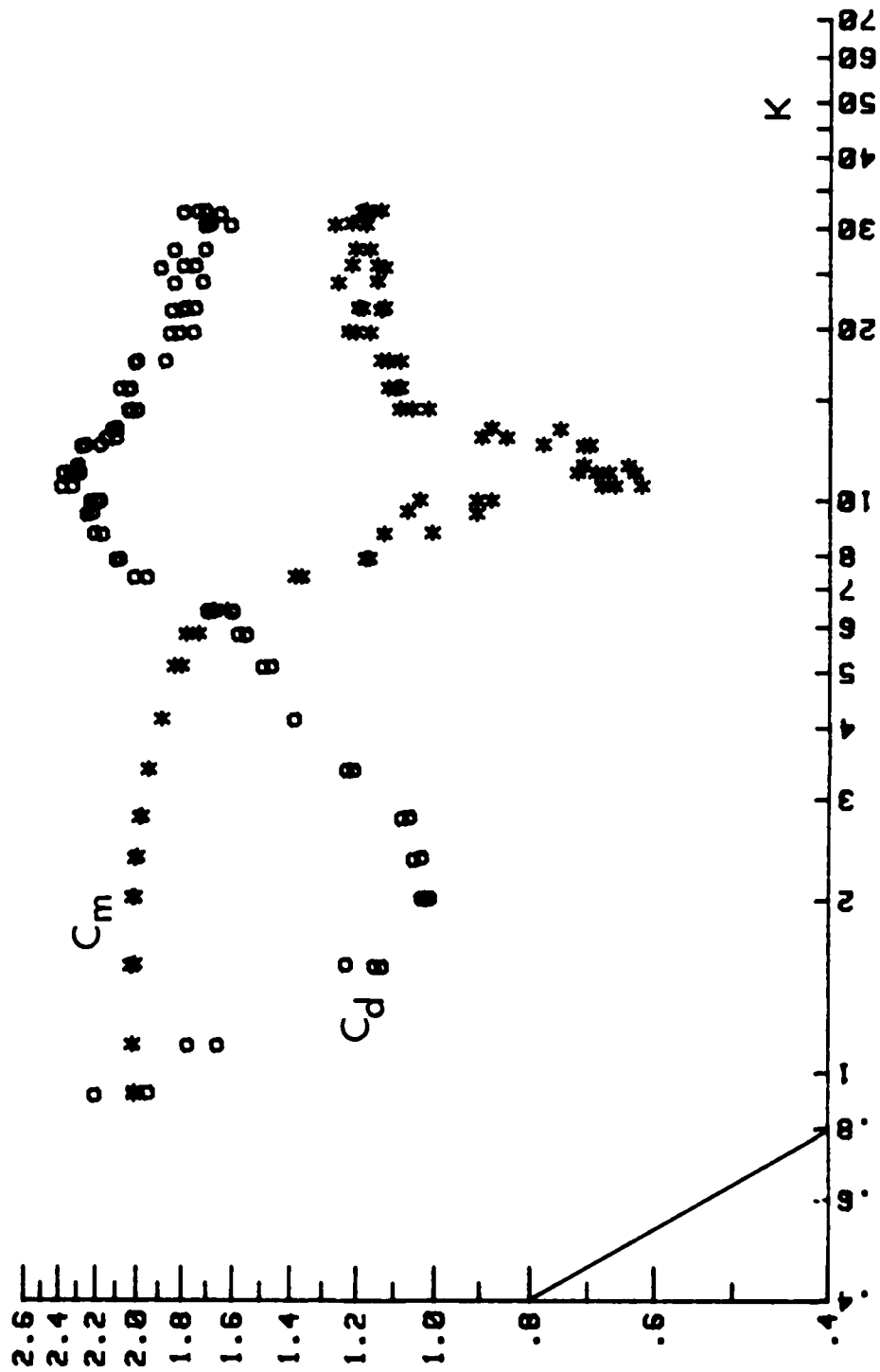

Fig. 35 Drag and inertia coefficients for a rough cylinder as a function of  $K$ ,  
 $\beta = 6836$ ,  $k/D = 1/50$ .

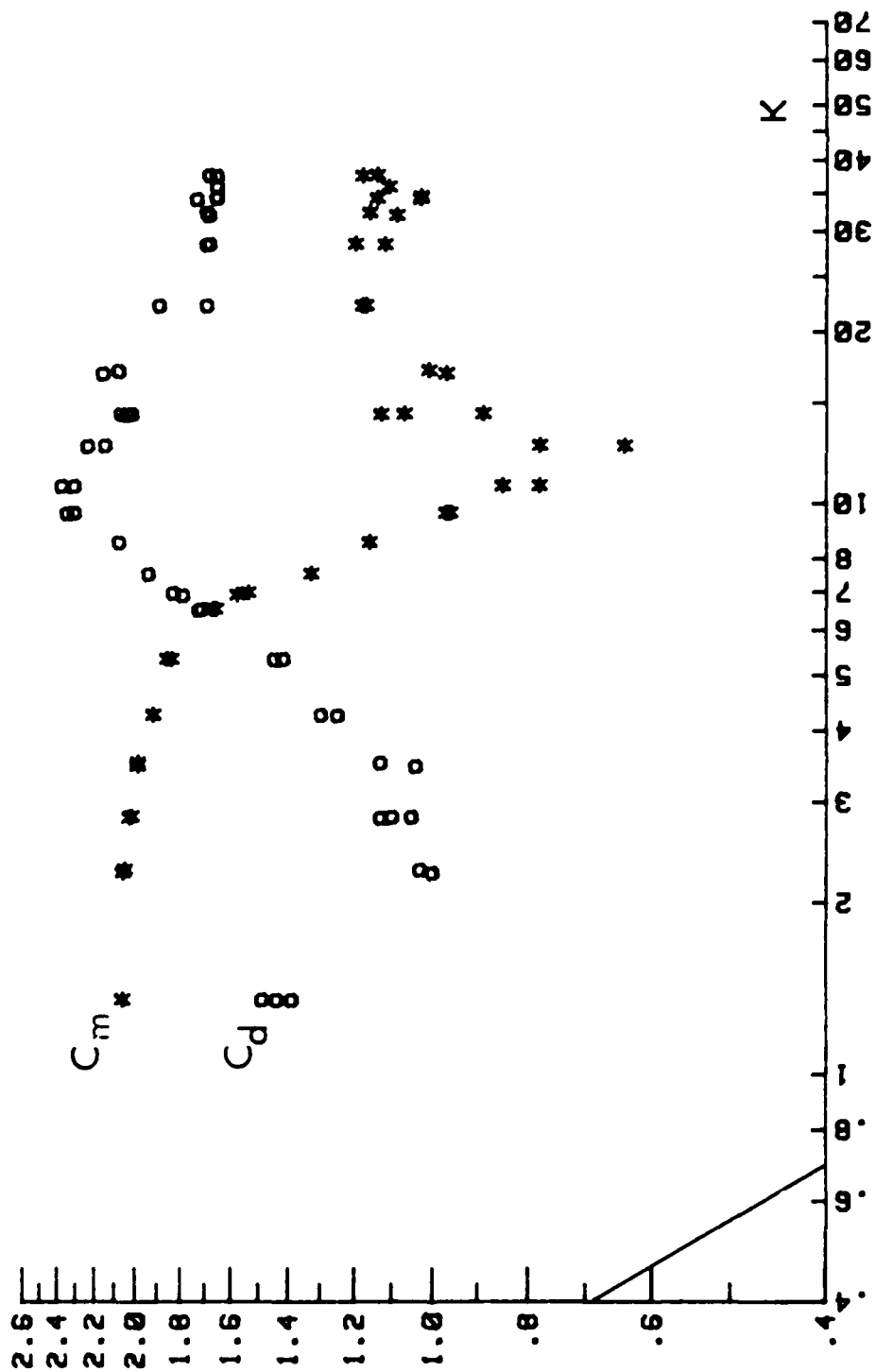

Fig. 36 Drag and inertia coefficients for a rough cylinder as a function of  $K$ ,  
 $\beta = 9351$ ,  $k/D = 1/50$ .

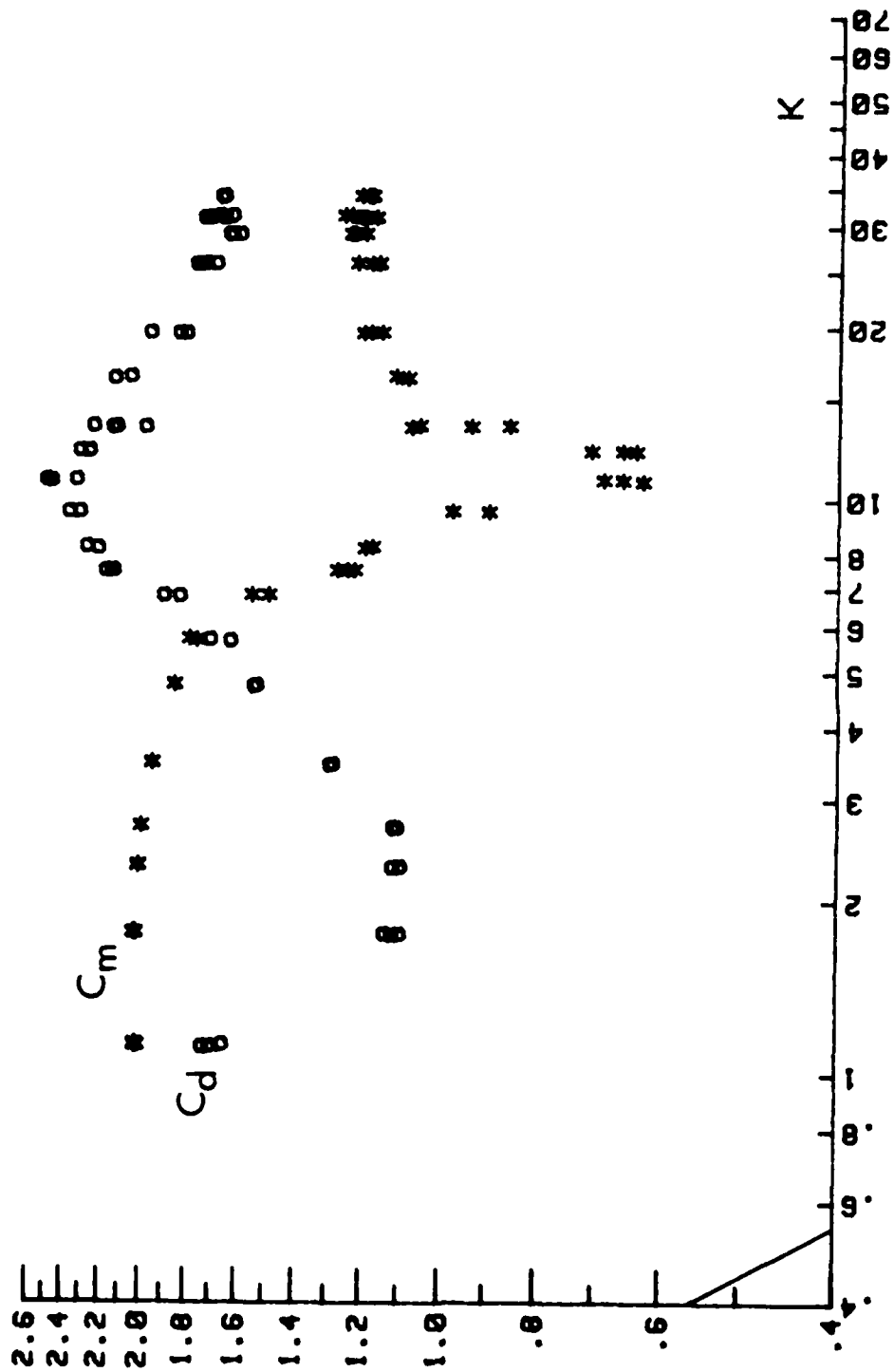

Fig. 37 Drag and inertia coefficients for a rough cylinder as a function of  $K$ ,  
 $\beta = 14200$ ,  $k/D = 1/50$ .

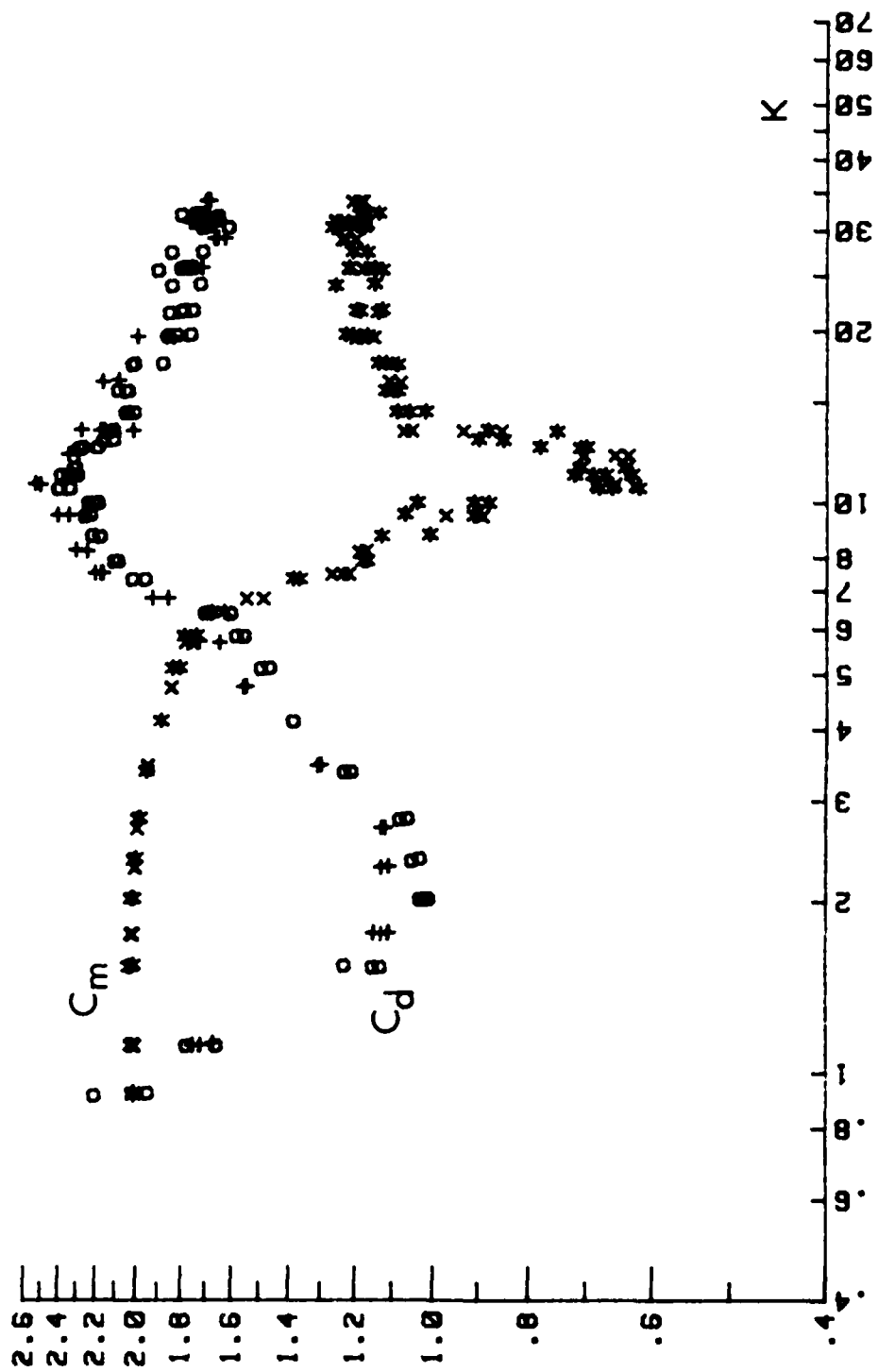

Fig. 38 Drag and inertia coefficients for two rough cylinders as a function of  $K$ ,  
 o ( $C_m$ ) and \* ( $C_d$ ) for  $\beta = 6836$ ; + ( $C_m$ ) and x ( $C_d$ ) for  $\beta = 14200$ .

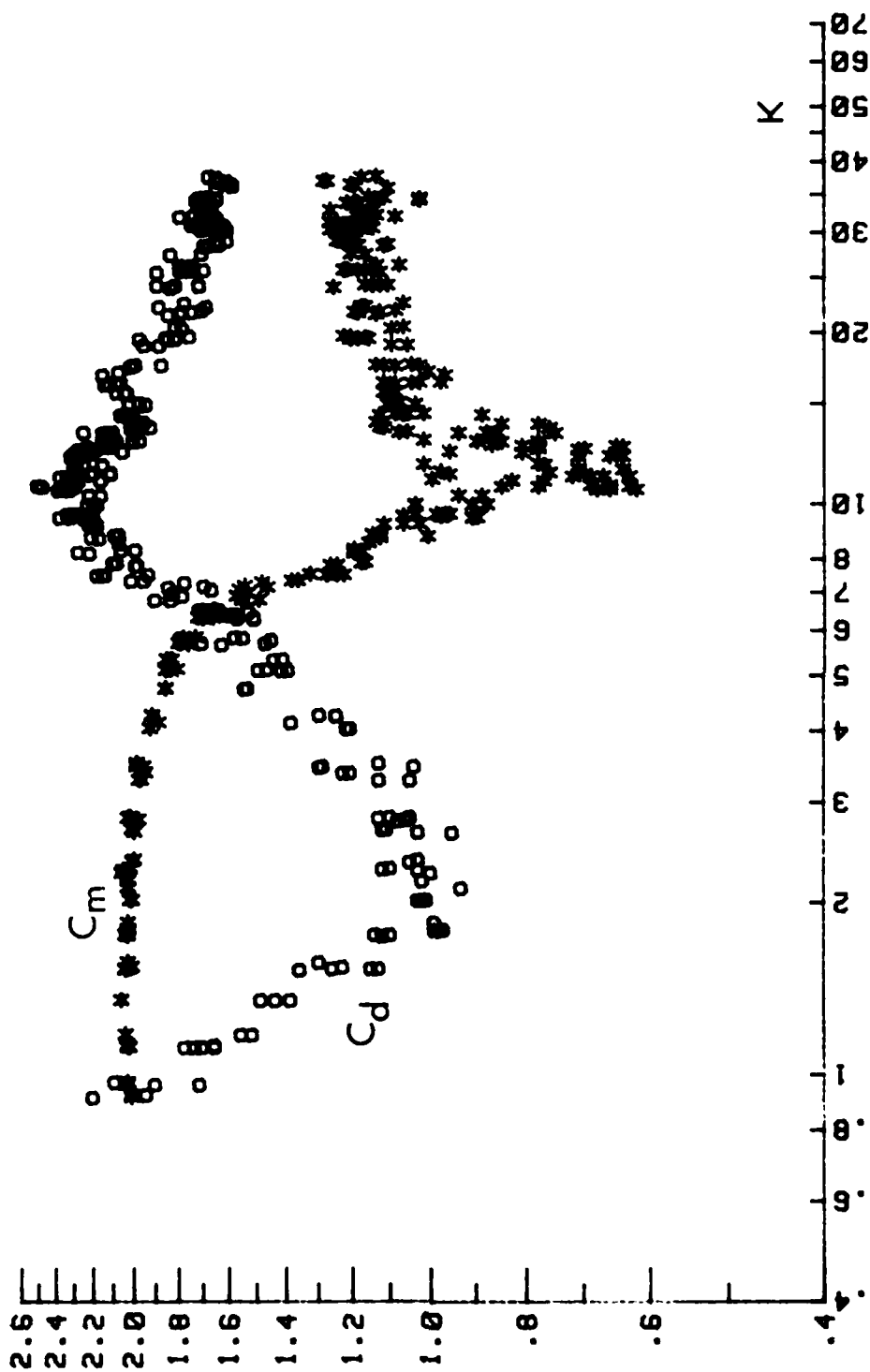

Fig. 39 Comparison of drag and inertia coefficients for four rough cylinders.  
 o ( $C_d$ ), \* ( $C_m$ ) for  $\beta = 4924, 6836, 9354, \text{ and } 14200$ .

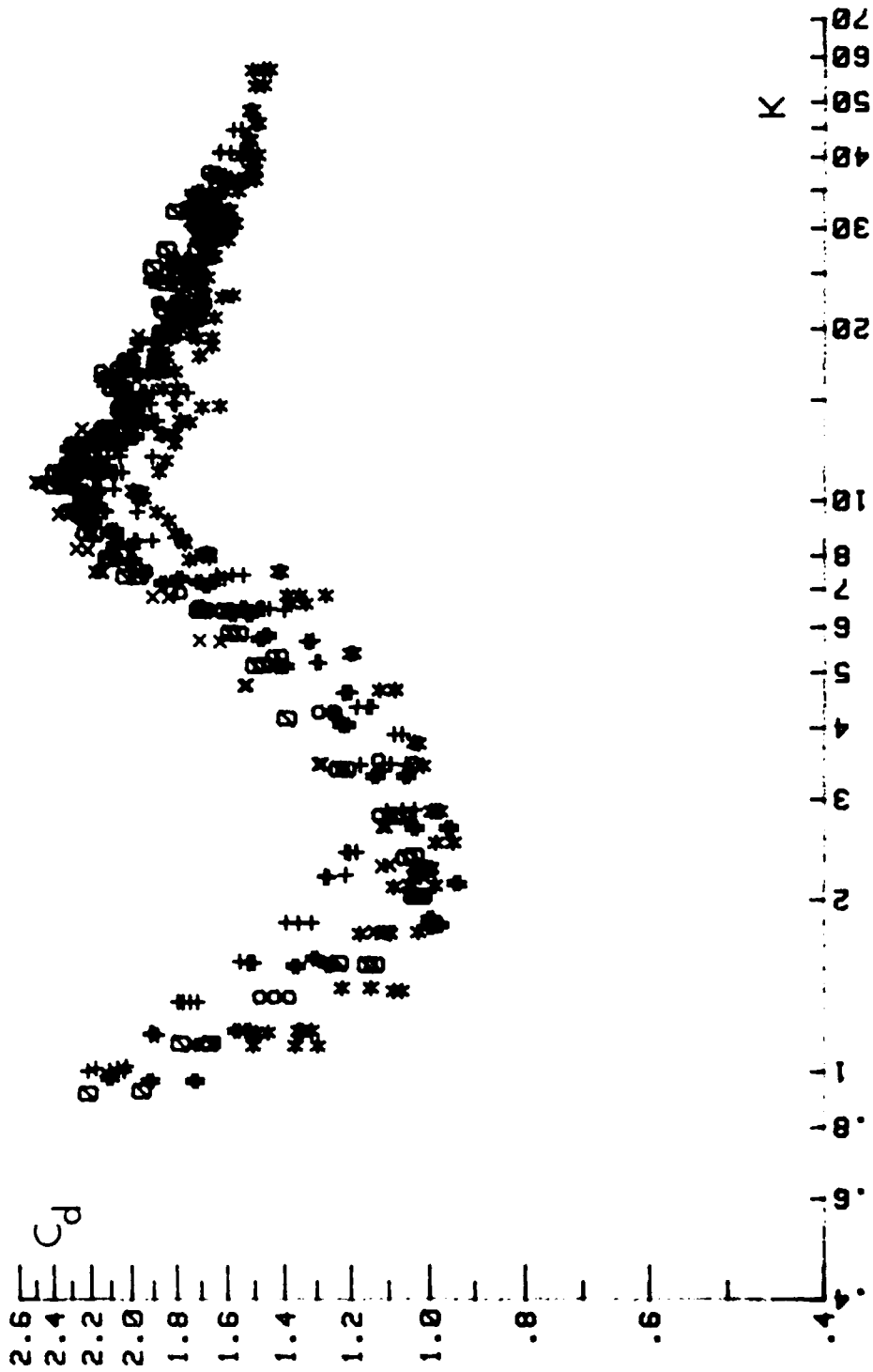

Fig. 40 Comparison of drag coefficients for six rough cylinders,

$*$ ,  $\beta = 2112$ ;  $+$ ,  $\beta = 3598$ ;  $\#$ ,  $\beta = 4924$ ;  $\circ$ ,  $\beta = 6836$ ;  $x$ ,  $\beta = 9354$ ;  $\beta = 14200$ .

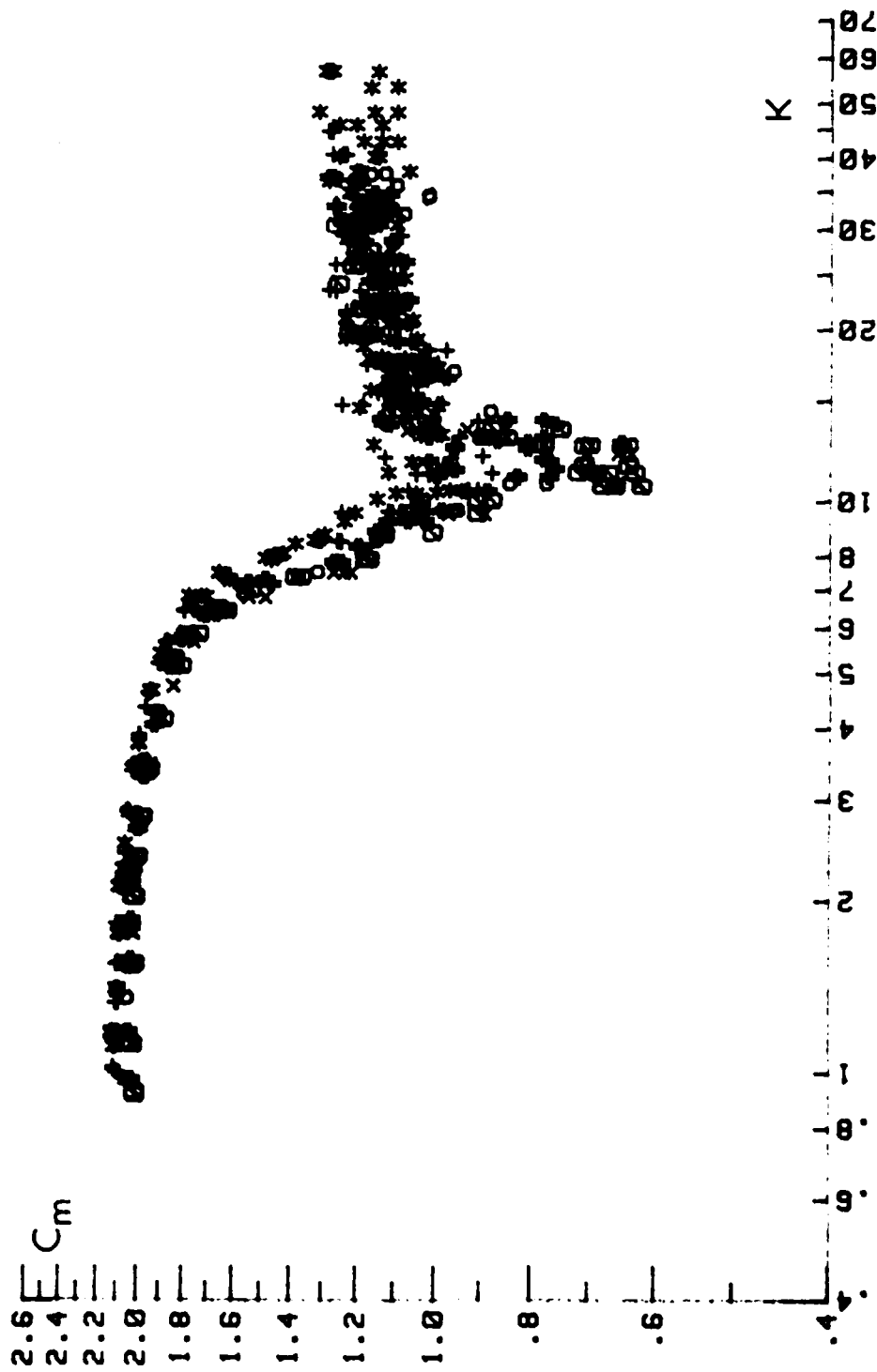

Fig. 41 Comparison of inertia coefficients for six rough cylinders.

\*,  $\beta = 2412$ ; +,  $\beta = 3598$ ; #,  $\beta = 4924$ ;  $\phi$ ,  $\beta = 6836$ ; o,  $\beta = 9354$ ; x,  $\beta = 14200$ .

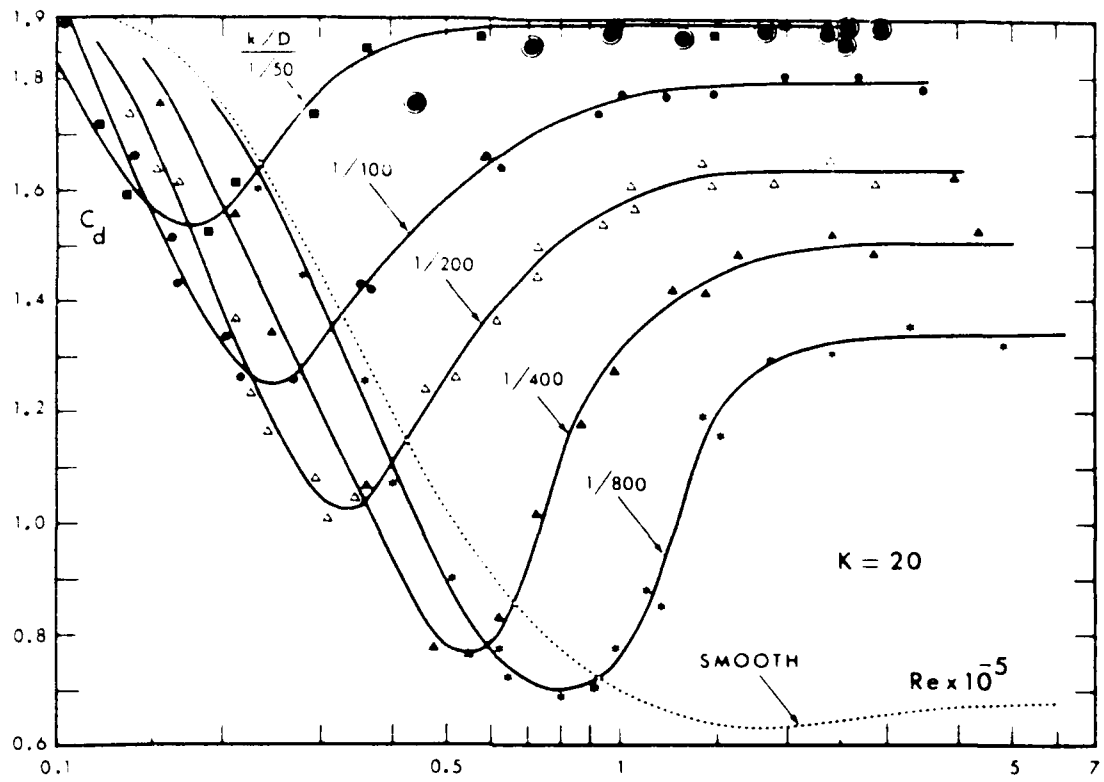

Fig. 42  $C_d$  versus  $Re$  for  $K = 20$  (from [2]);  $\bullet$ , present data for  $k/D=1/50$ .

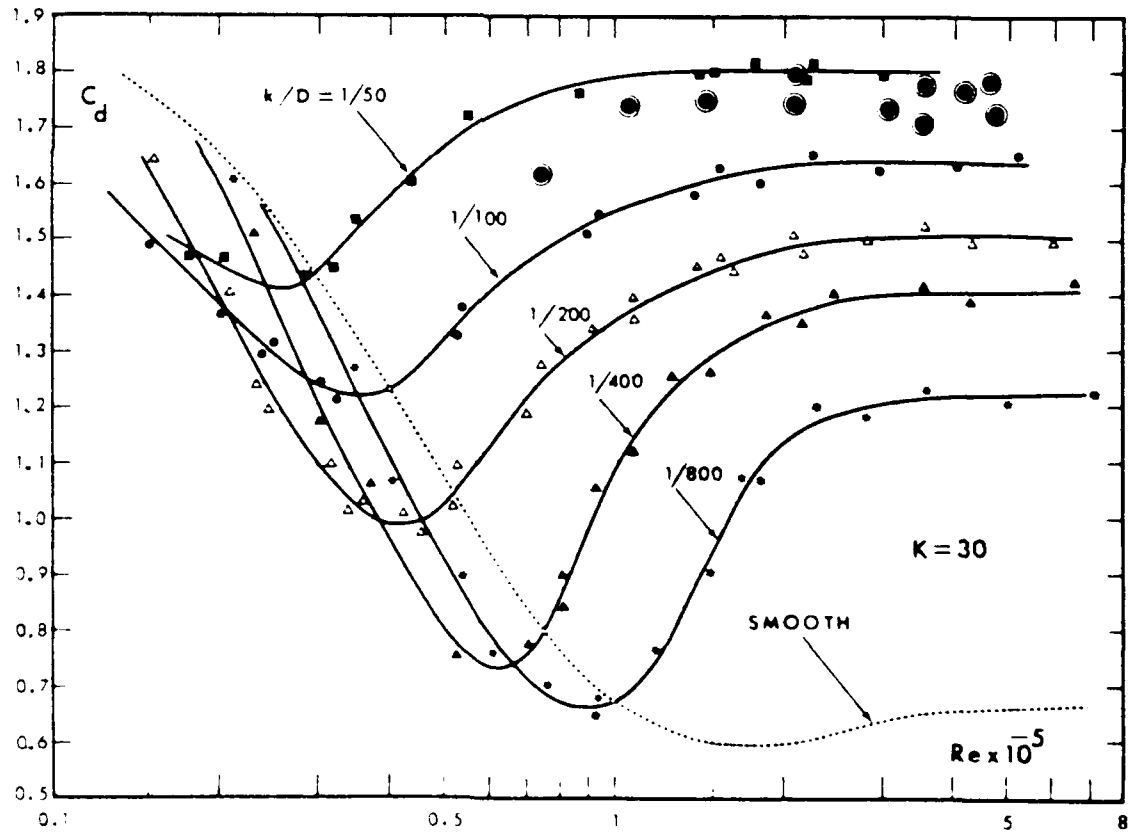

Fig. 43  $C_d$  versus  $Re$  for  $K = 30$  (from [2]);  $\bullet$ , present data for  $k/D=1/50$ .

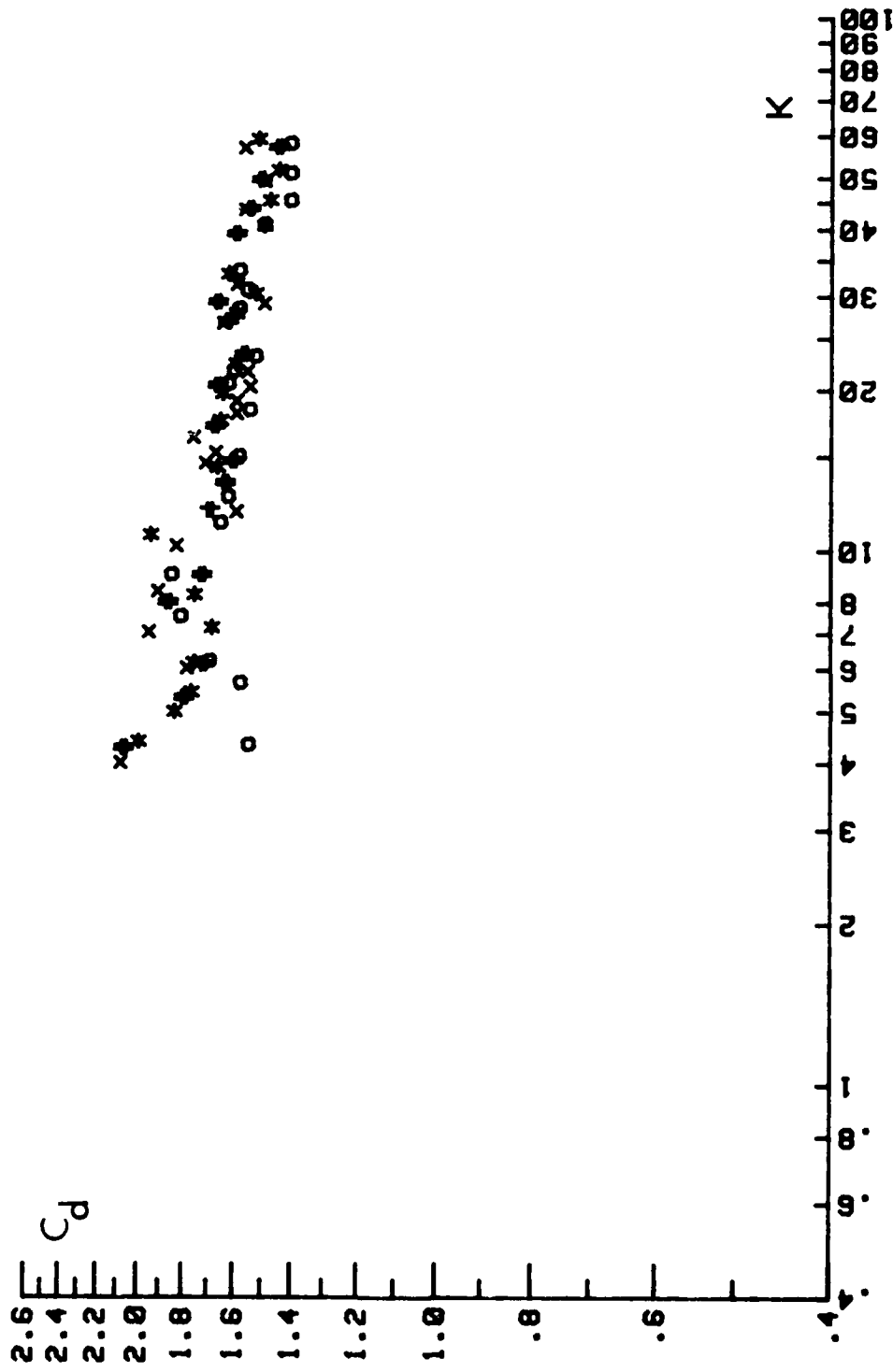
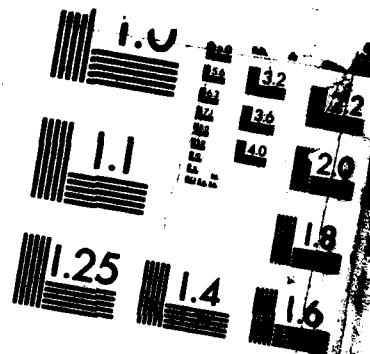

Fig. 44 Drag coefficient for the marine-roughened cylinder (position A),

o,  $\beta = 8100$ ; x,  $\beta = 10964$ ; #,  $\beta = 13724$ ; \*,  $\beta = 13890$ .





MICROCOPY RESOLUTION TEST CHART  
NATIONAL BUREAU OF STANDARDS-1963-A

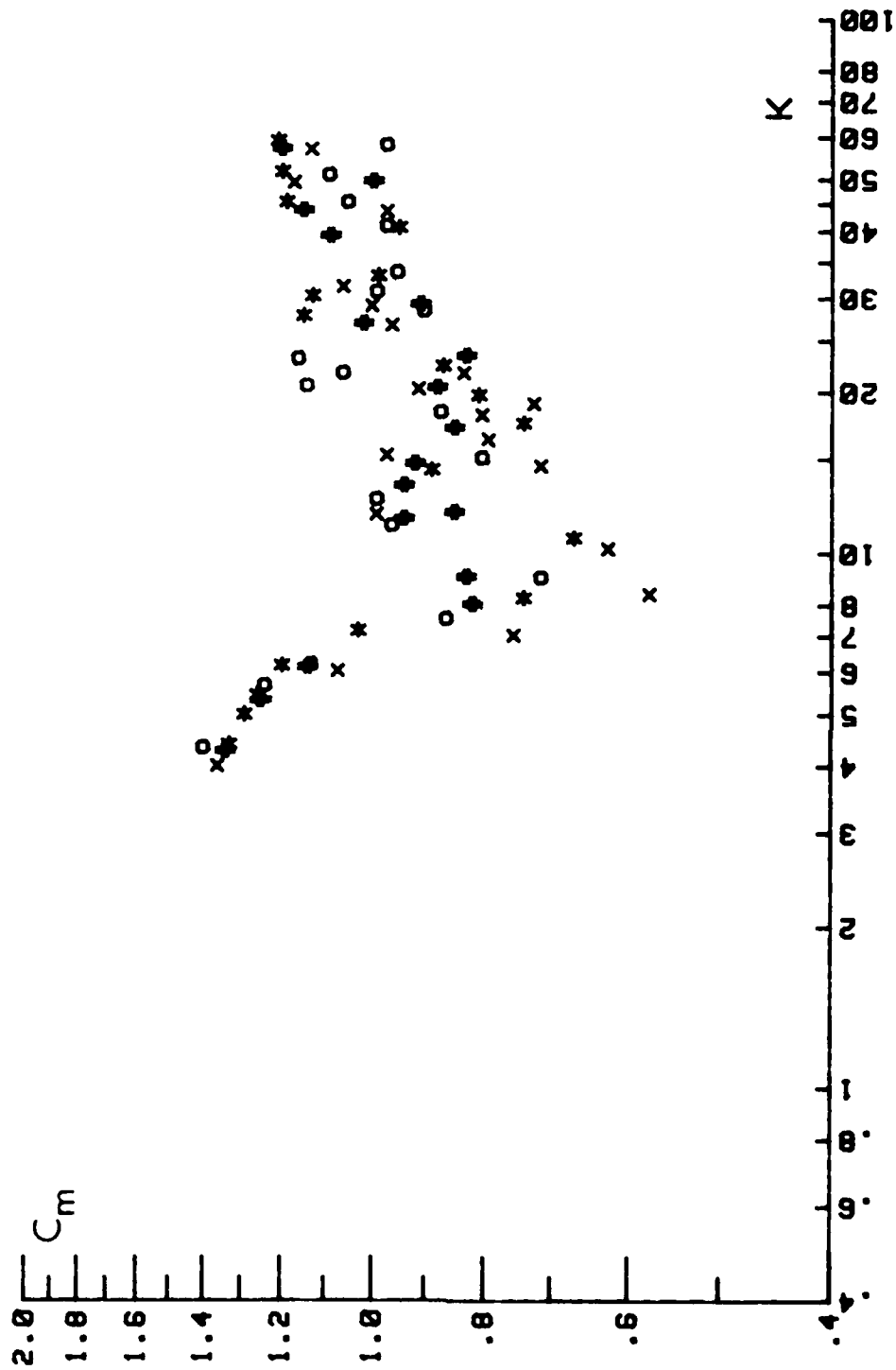

Fig. 45 Inertia coefficient for the marine-roughened cylinder (position A),  
 o,  $\beta = 8100$ ; x,  $\beta = 10964$ ; #,  $\beta = 13724$ ; \*,  $\beta = 13890$ .

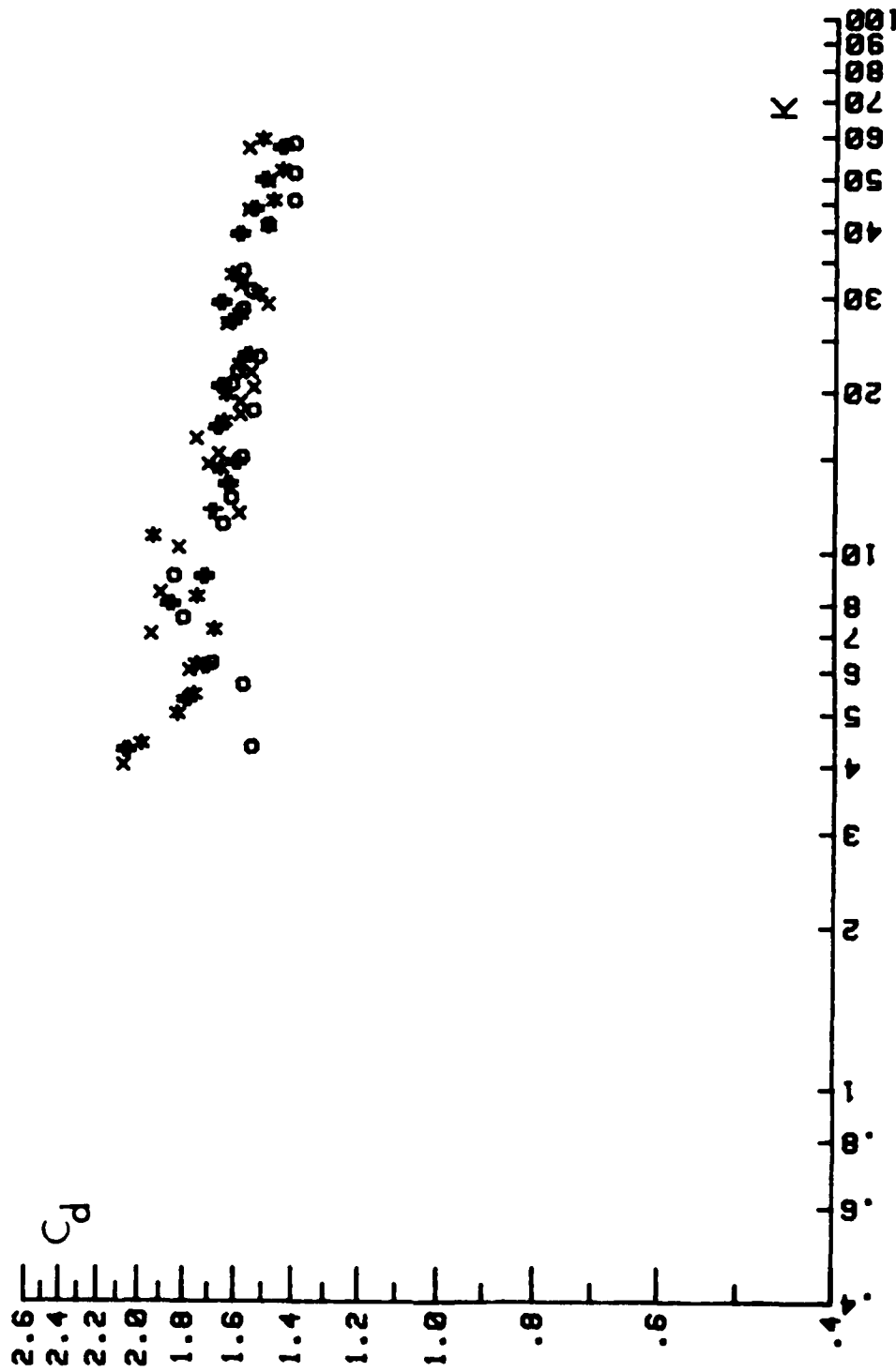

Fig. 44 Drag coefficient for the marine-roughened cylinder (position A),  
 o,  $\beta = 8100$ ; x,  $\beta = 10964$ ; #,  $\beta = 13724$ ; \*,  $\beta = 13890$ .

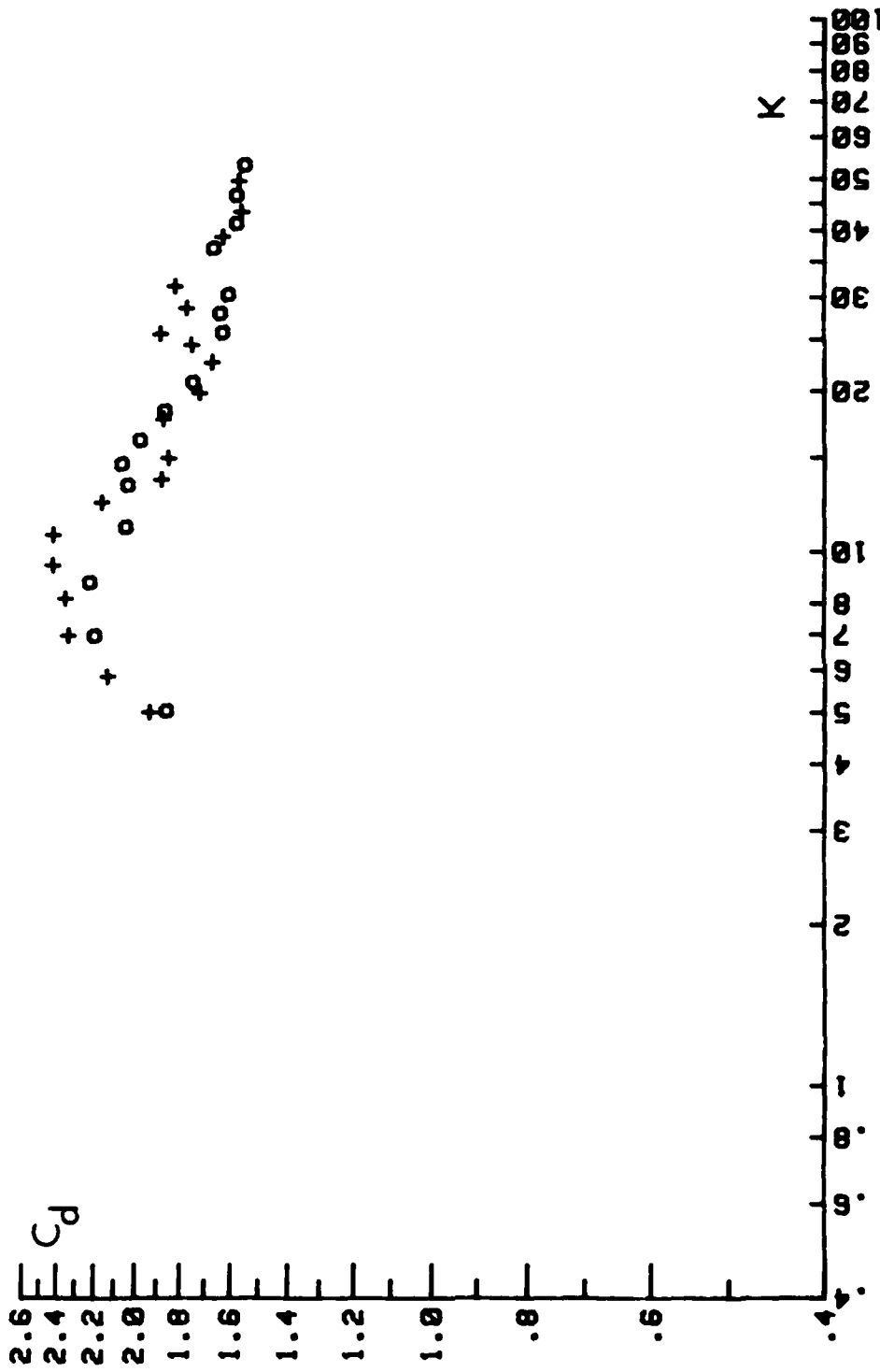

Fig. 46 Drag coefficient for the marine roughened cylinder (position B),

o,  $\beta = 13122$ ; +,  $\beta = 13517$ .

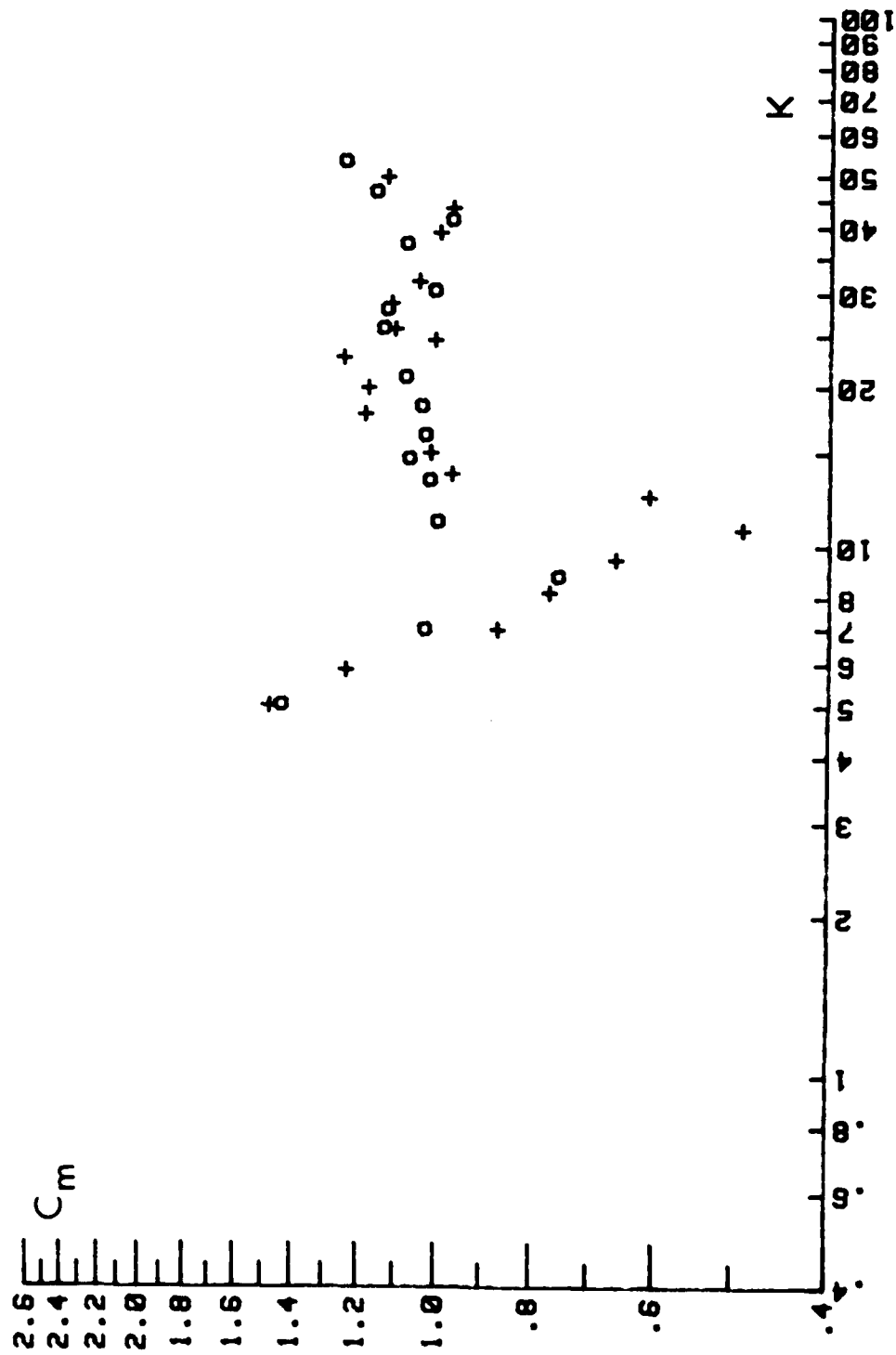

Fig. 47 Inertia coefficient for the marine-roughened cylinder (position B),  
 o,  $\beta = 13122$ ; +,  $\beta = 13517$ .

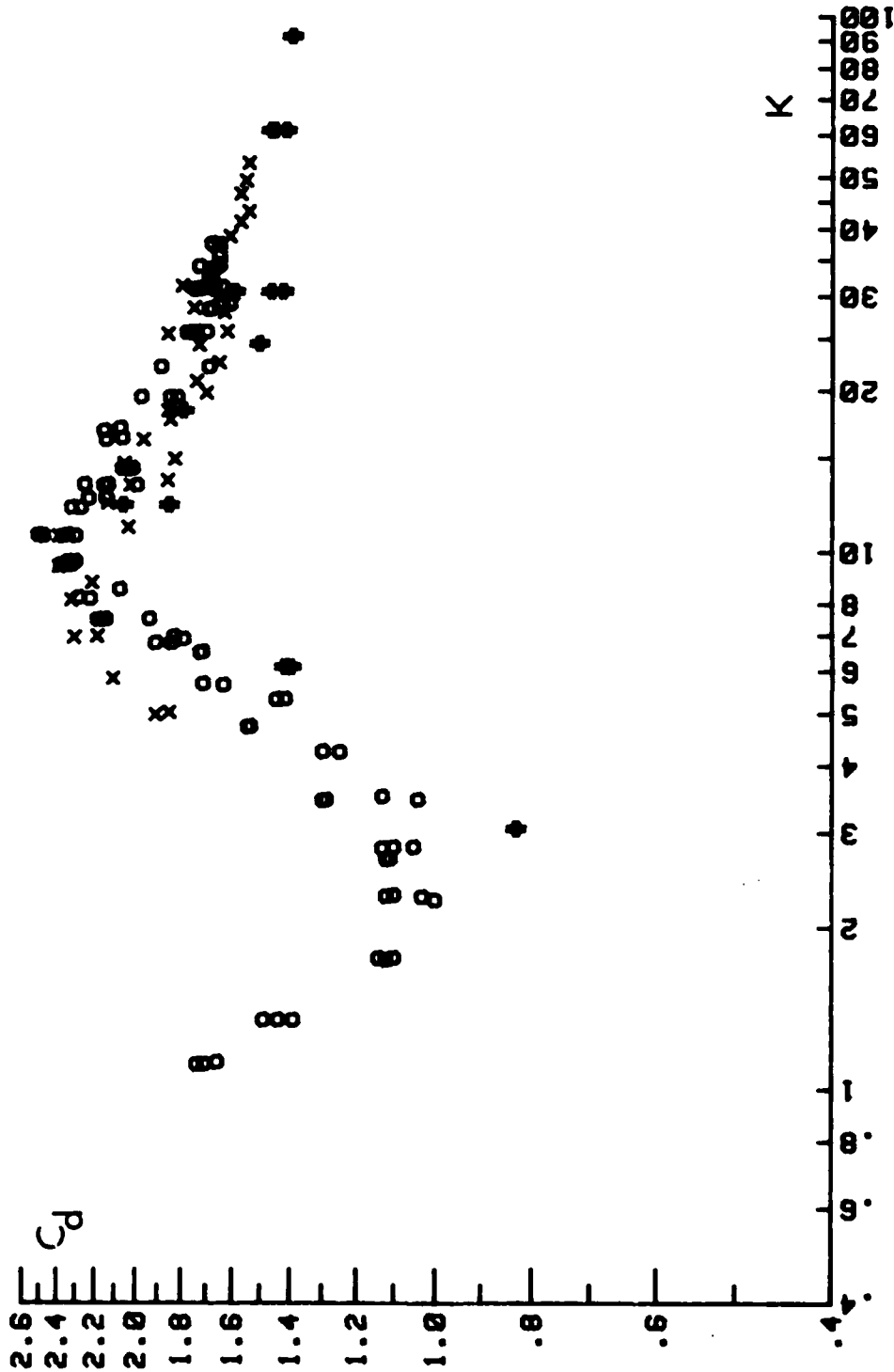

Fig. 48 Comparison of the present drag coefficient data with those obtained by Rodenbusch and Gutierrez [7]: Sand-roughened cylinders: o,  $\beta = 9354$  and 14200; marine-roughened cylinders: x,  $\beta = 13122$  and 13517; Rodenbusch & Gutierrez: #,  $\beta = 7000$  to 140,000.

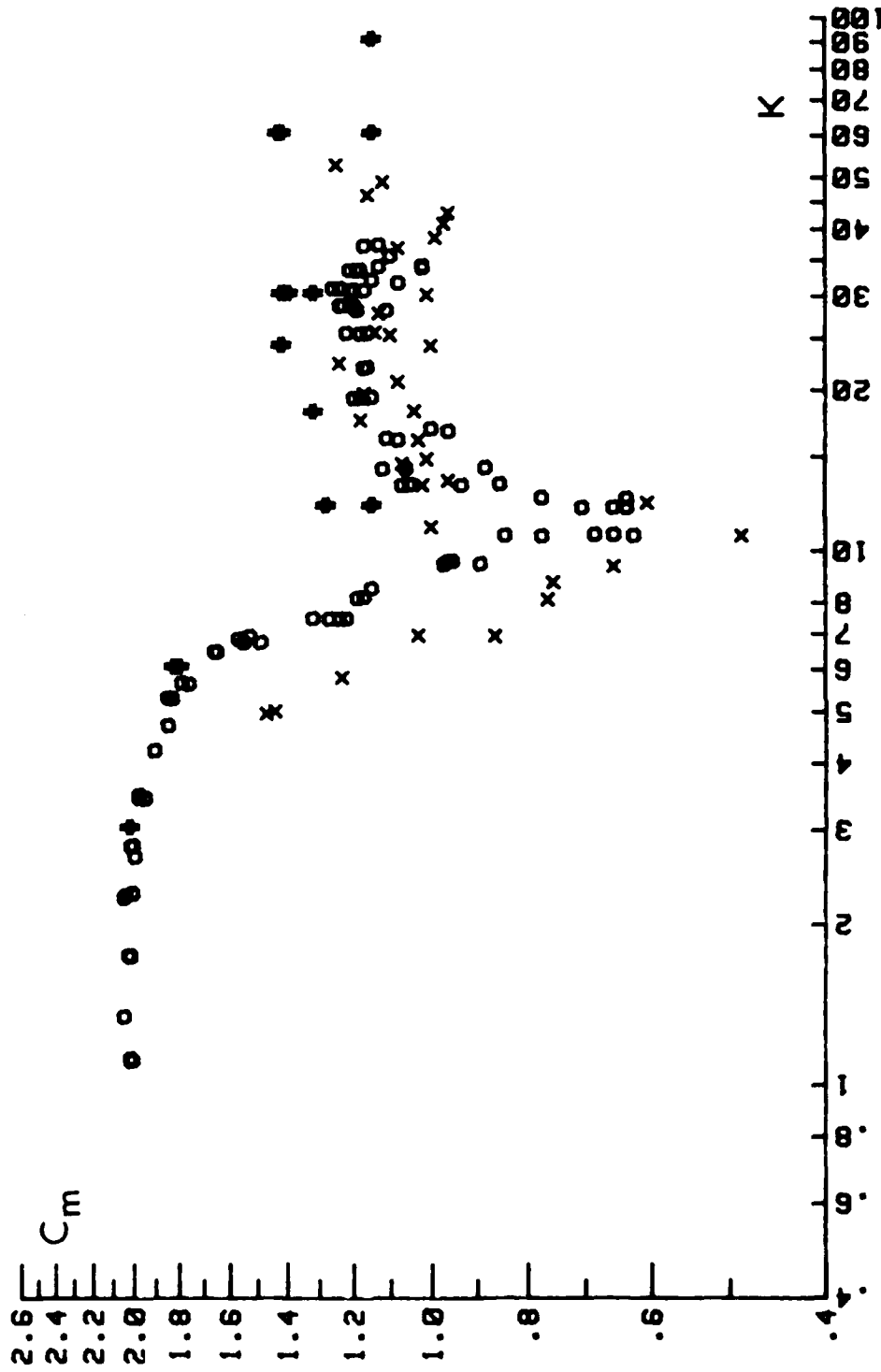

Fig. 49 Comparison of the present inertia coefficient data with those obtained by Rodenbusch and Gutierrez [7]: Sand-roughened cylinders: o,  $\beta = 9354$  and 14200; marine-roughened cylinders: x,  $\beta = 13122$  and 13517; Rodenbusch & Gutierrez: +,  $\beta = 7000$  to 140,000.

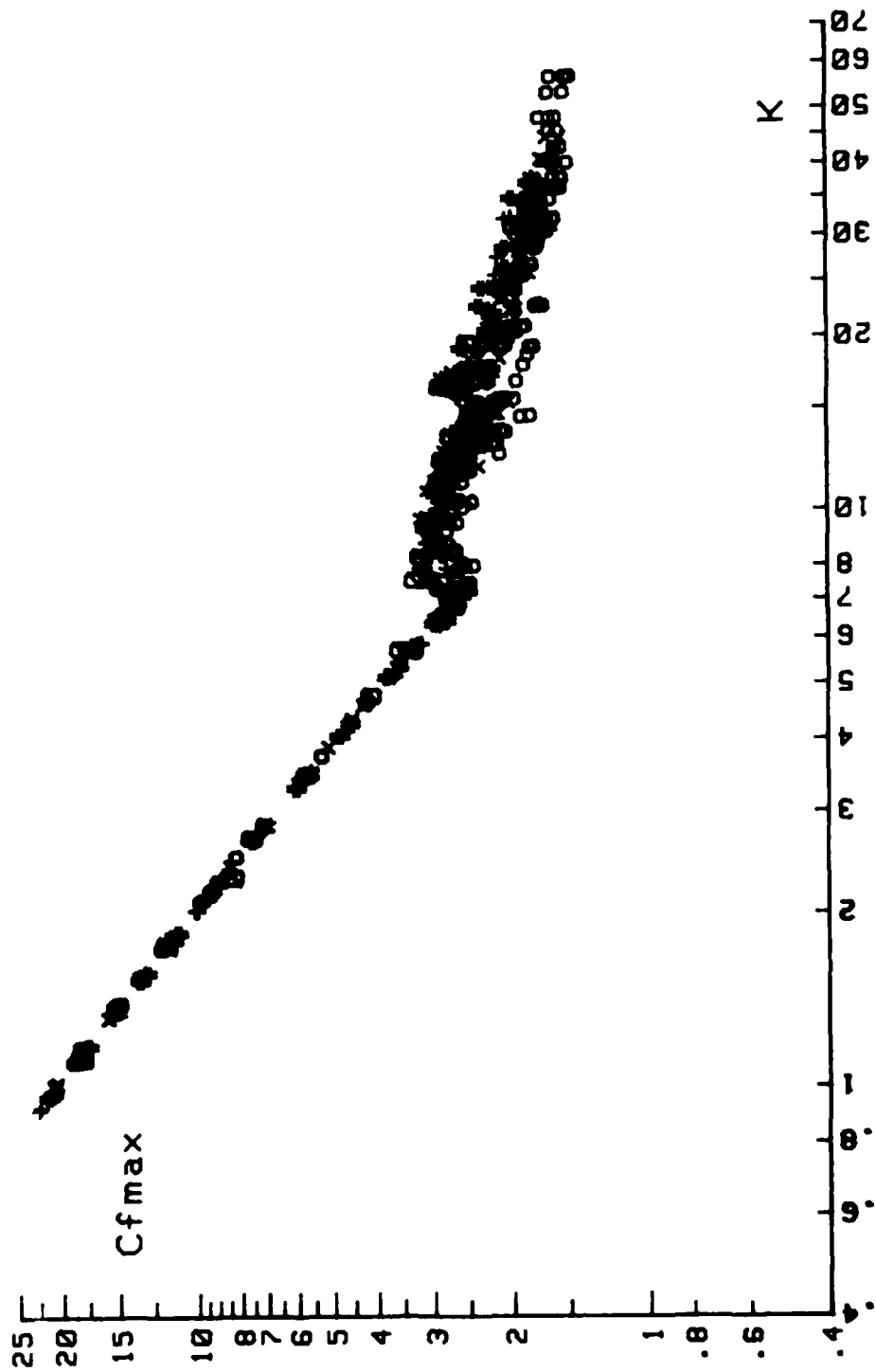

Fig. 50 Maximum force coefficient for rough cylinders as a function of K,  
 o,  $\beta = 2412$ ; x,  $\beta = 3598$ ; #,  $\beta = 4924$ ; +,  $\beta = 6836$ ; \*,  $\beta = 9354$ ;  $\phi$ ,  $\beta = 14200$ .

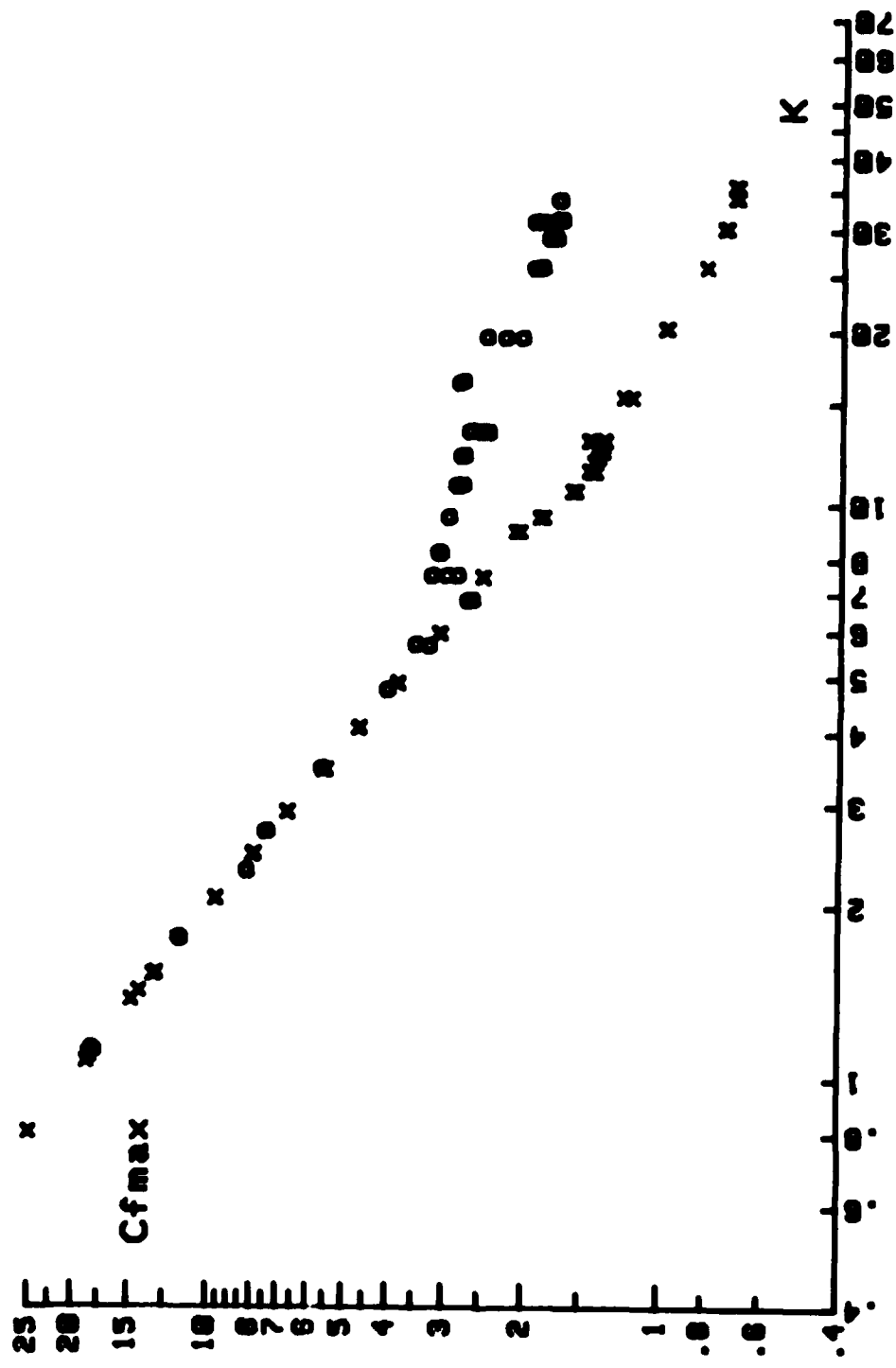

FIG. 51 Maximum force coefficient for a smooth and sand-roughened cylinder, smooth cylinder: x,  $\beta = 11525$ ; rough cylinder: o,  $\beta = 14200$ .

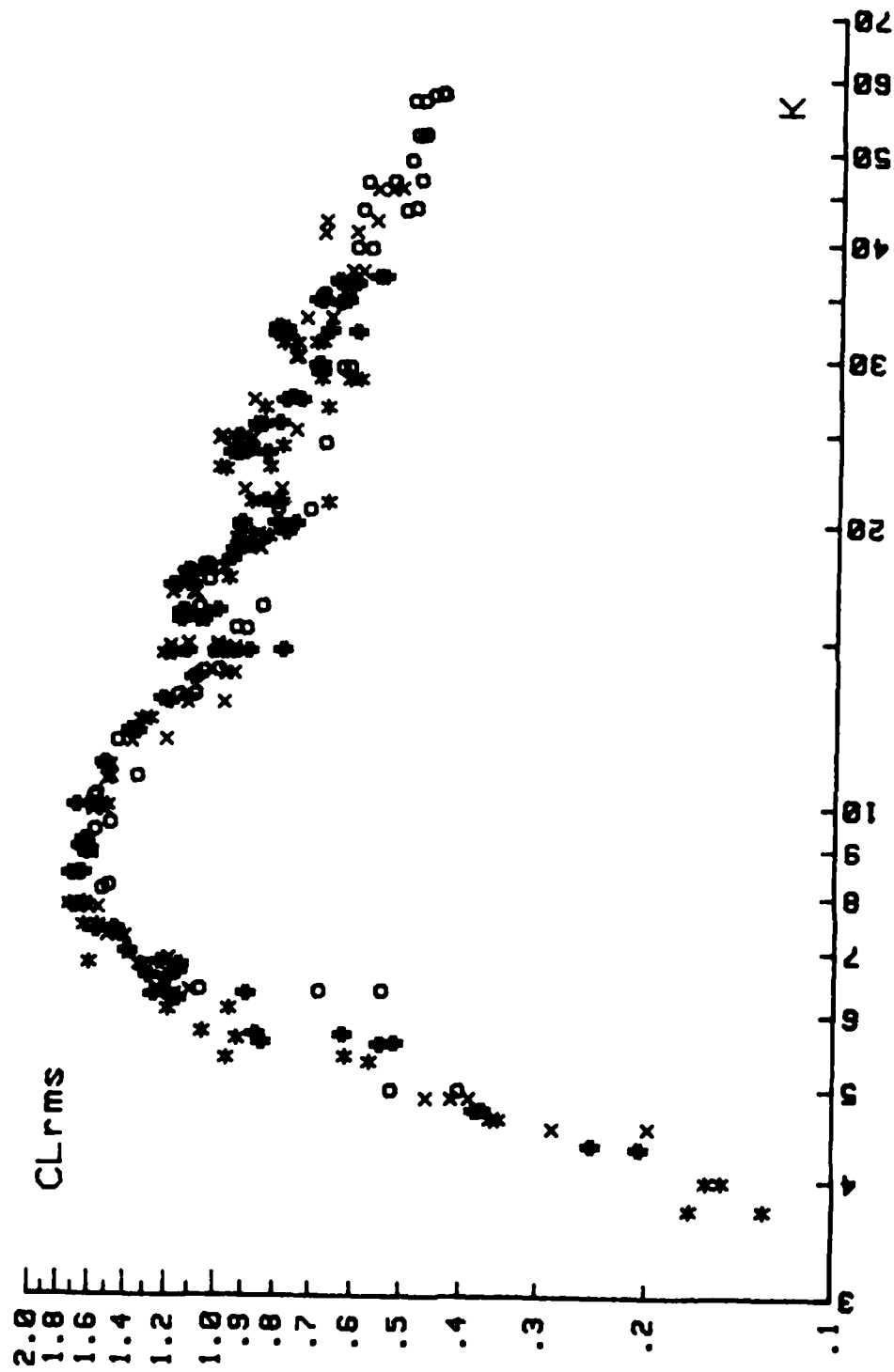

Fig. 52 RMS lift coefficient for rough cylinders as a function of  $K$ ,  
 o,  $\beta = 2412$ ; x,  $\beta = 4924$ ; and \*,  $\beta = 6836$ .

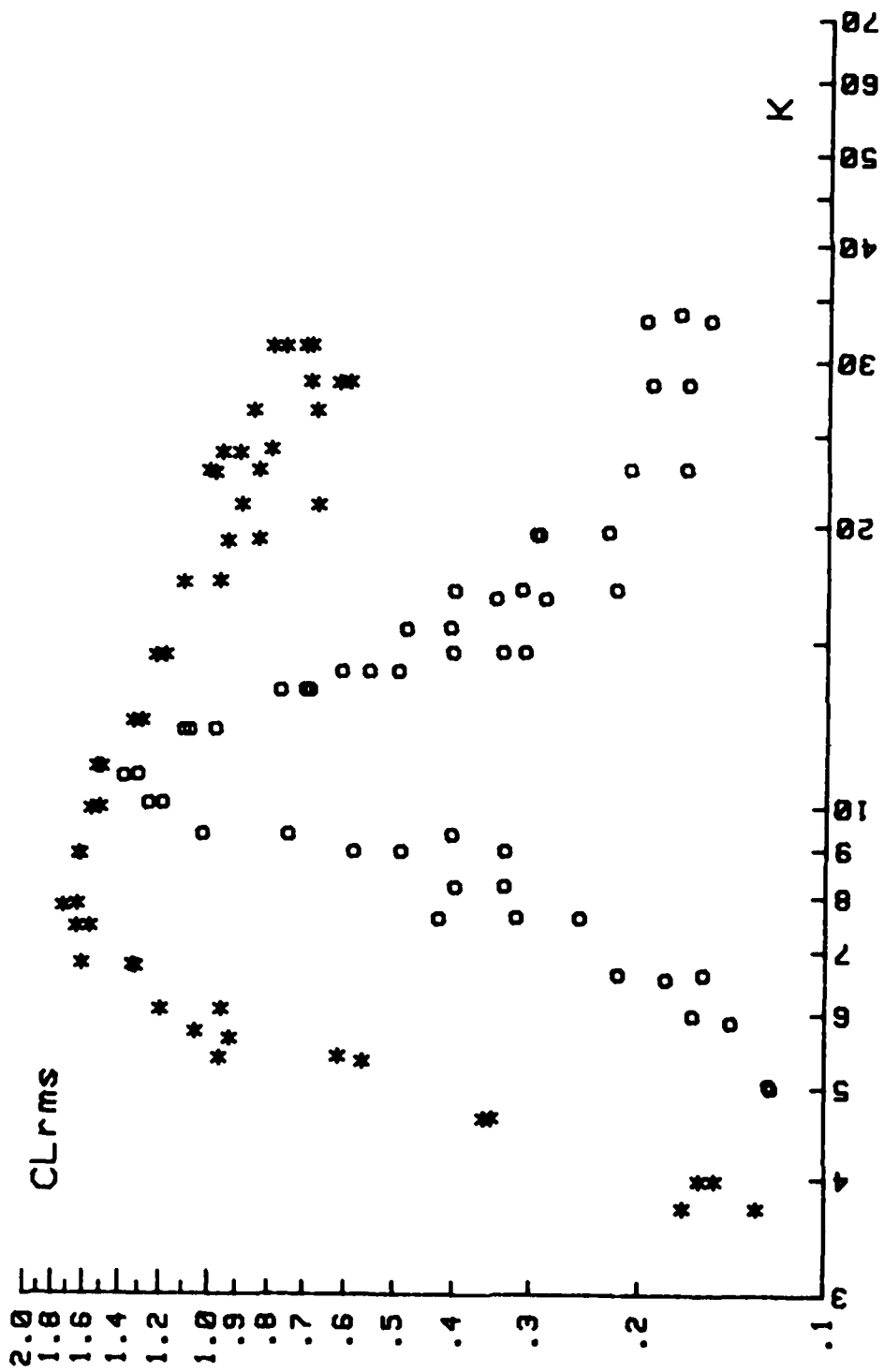

Fig. 53 RMS lift coefficient for a smooth and sand-roughened cylinder.  
 smooth cylinder: o,  $\beta = 6555$ ; rough cylinder: \*,  $\beta = 6836$ .

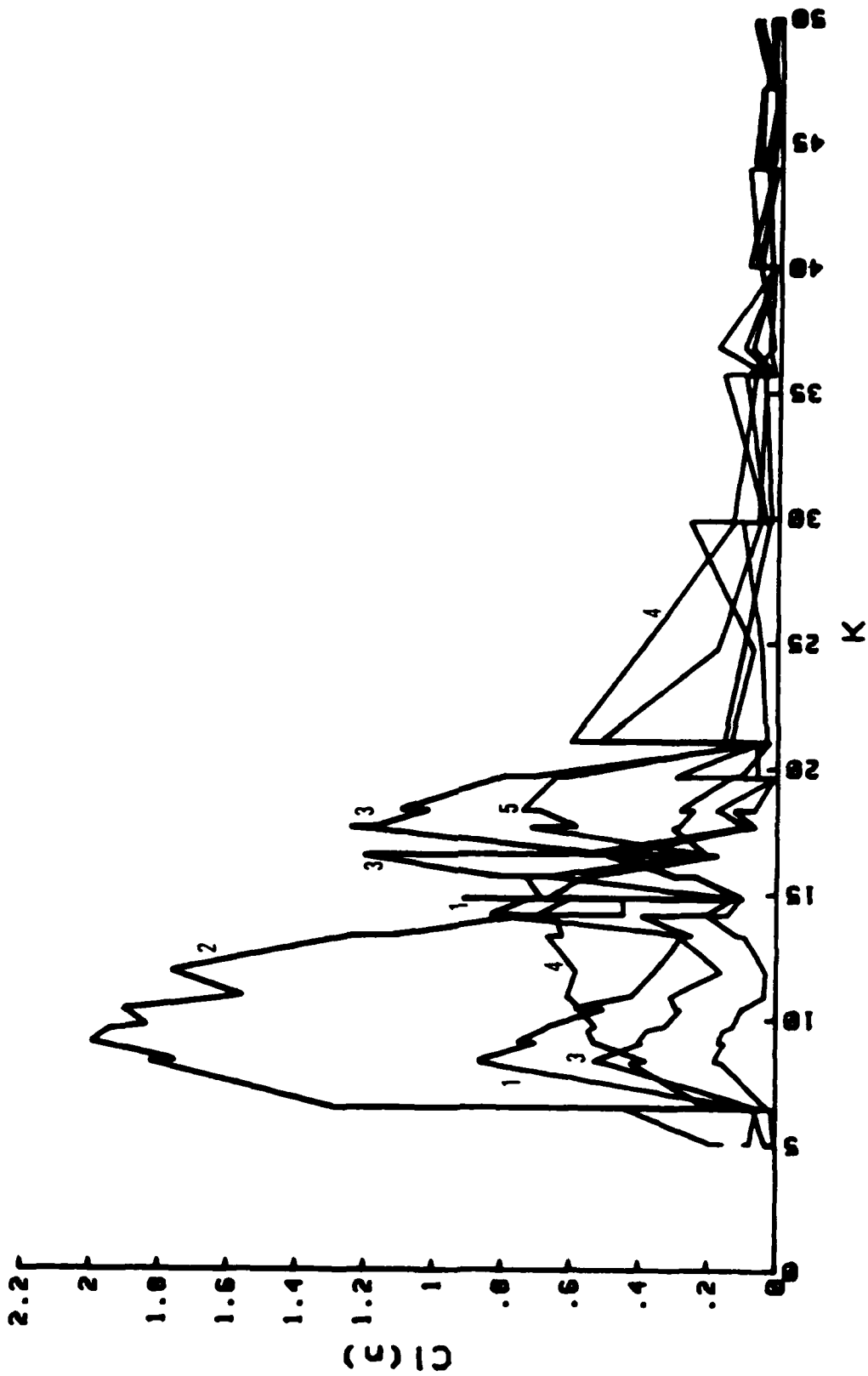

Fig. 54 Amplitude of the harmonics of the lift force for a rough cylinder,  $\beta = 2412$ .

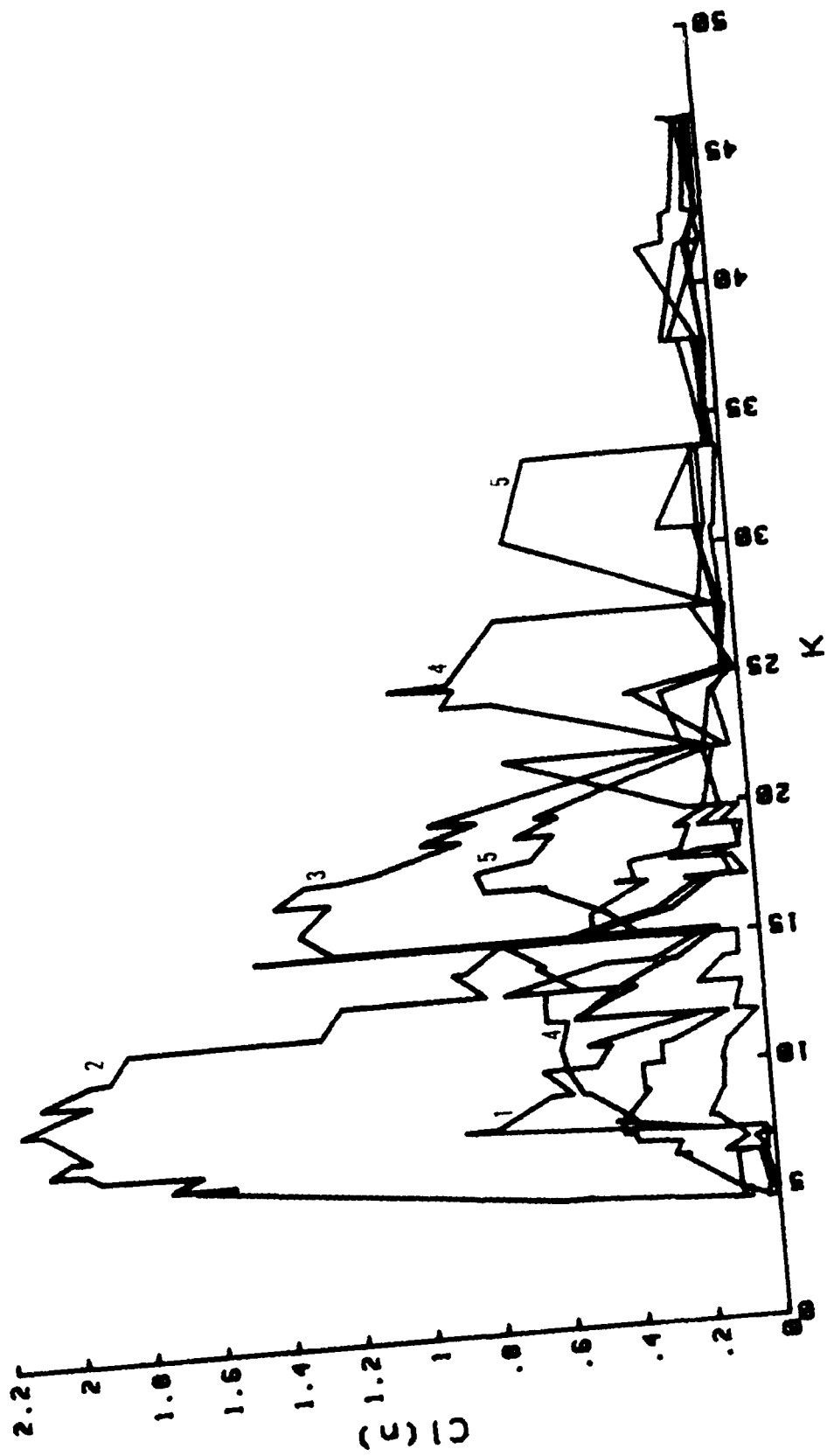

FIG. 55 Amplitude of the harmonics of the lift force for a rough cylinder,  $\beta = 3598$ .

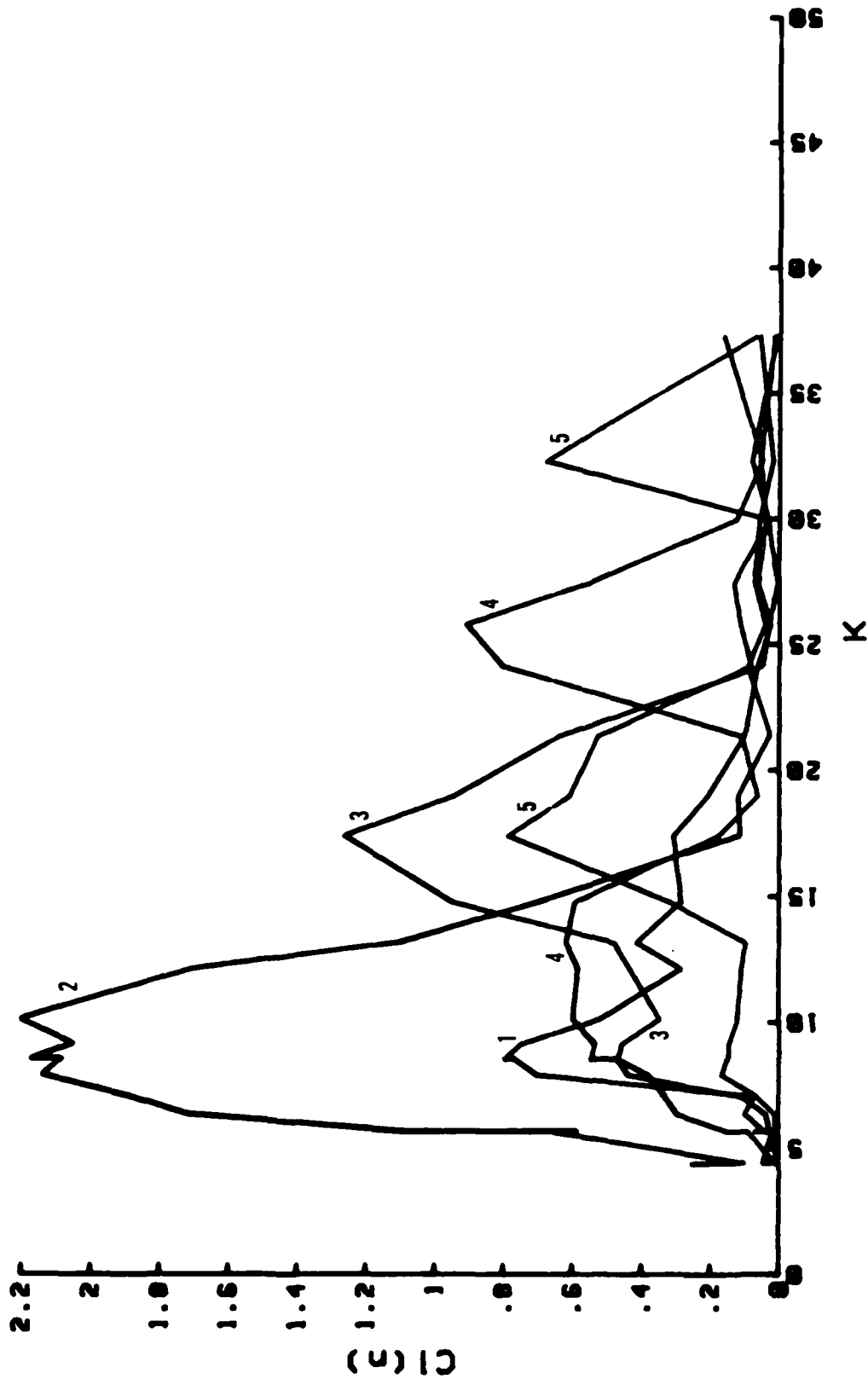

Fig. 56 Amplitude of the harmonics of the lift force for a rough cylinder,  $\beta = 4924$ .

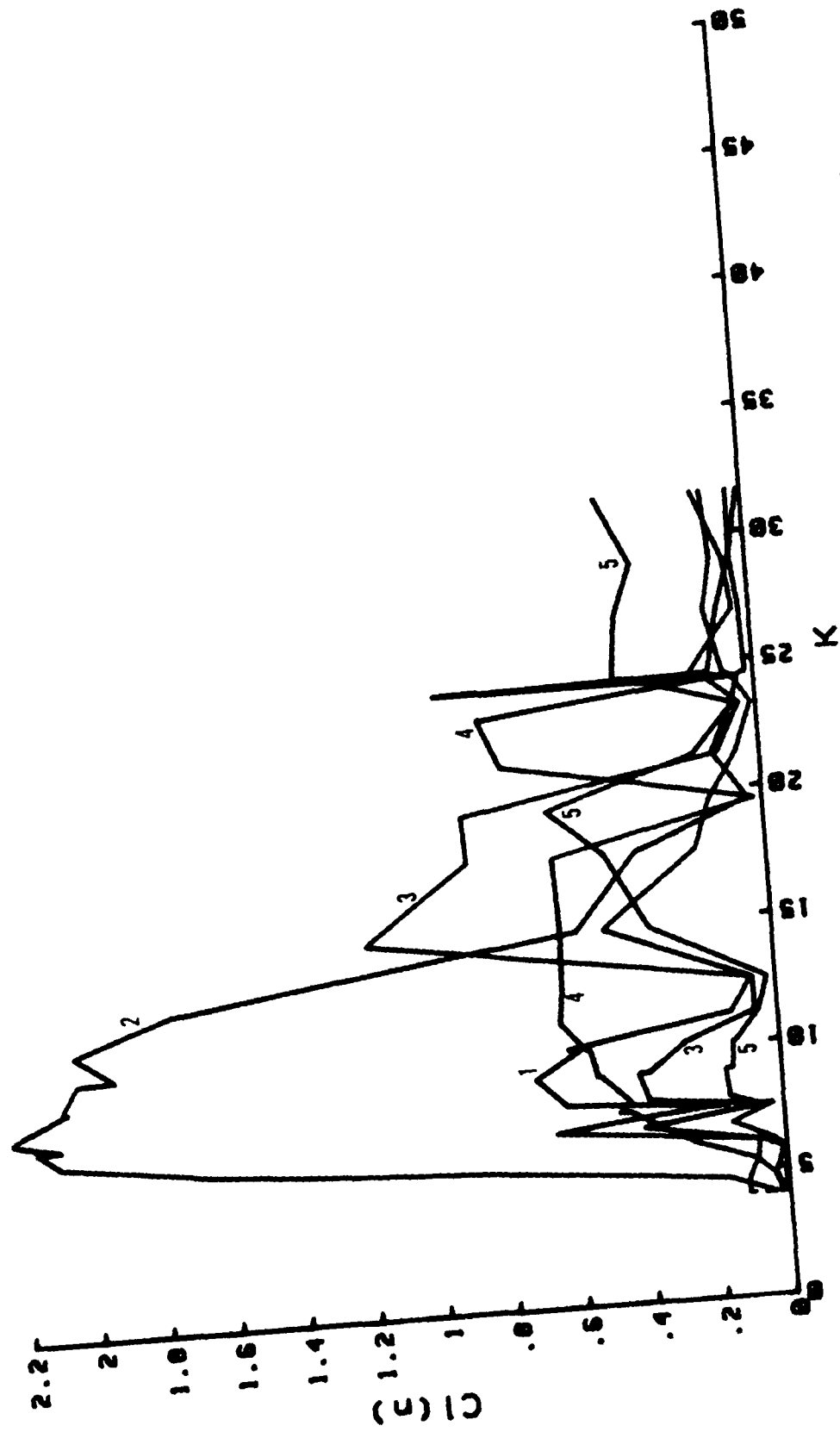

Fig. 57 Amplitude of the harmonics of the lift force for a rough cylinder,  $\beta = 6836$ .

APPENDIX A:  
 IN-LINE FORCE COEFFICIENTS FOR SMOOTH CYLINDERS  
 BETA = 2300 ,  $k/D = 0$

#	K	Cd	Cm	Cfmax	Carms
1	1.02	1.29	2.08	22.02	14.30
2	1.02	1.25	2.06	21.41	14.11
3	1.39	.99	2.07	15.73	10.41
4	1.40	1.02	2.07	15.41	10.35
5	1.40	1.15	2.06	15.41	10.28
6	1.41	.97	2.06	15.48	10.22
7	2.40	.79	2.02	8.91	5.90
8	2.40	.87	2.02	8.78	5.90
9	2.78	.86	2.00	7.59	5.05
10	2.80	.77	1.99	7.42	4.96
11	2.81	.86	1.98	7.34	4.94
12	2.82	.86	1.97	7.27	4.92
13	3.76	.99	1.93	5.31	3.63
14	3.78	.86	1.93	5.43	3.59
15	4.80	1.05	1.87	4.19	2.80
16	4.80	1.02	1.87	4.17	2.79
17	4.80	.96	1.88	4.19	2.79
18	5.41	1.04	1.85	3.71	2.47
19	5.41	1.02	1.85	3.76	2.47
20	6.22	1.13	1.80	3.19	2.13
21	6.23	1.20	1.79	3.17	2.13
22	6.38	1.15	1.79	3.13	2.08
23	6.38	1.18	1.79	3.13	2.08
24	6.60	1.18	1.78	3.02	2.01
25	6.61	1.17	1.77	2.98	2.00
26	7.22	1.14	1.76	2.76	1.84
27	7.22	1.15	1.73	2.72	1.81
28	8.44	1.34	1.59	2.27	1.54
29	8.46	1.19	1.67	2.26	1.55
30	8.48	1.17	1.69	2.29	1.56
31	9.25	1.43	1.33	2.00	1.38
32	9.33	1.25	1.63	2.05	1.42
33	9.62	1.63	1.05	2.54	1.32
34	9.78	1.51	1.14	2.42	1.28
35	9.98	1.65	1.04	2.71	1.30
36	10.12	1.64	.96	2.52	1.27
37	10.43	1.72	.90	2.47	1.27
38	10.45	1.71	.86	2.58	1.25
39	11.85	1.68	.73	2.55	1.18
40	11.89	1.74	.77	2.71	1.24
41	13.09	1.86	.54	2.52	1.24
42	13.11	1.84	.55	2.57	1.23
43	13.12	1.77	.63	2.30	1.19
44	13.94	1.80	.56	2.30	1.19
45	13.94	1.76	.51	2.15	1.16
46	13.95	1.71	.54	2.06	1.13
47	16.55	1.51	.61	1.91	1.01
48	16.55	1.57	.53	1.86	1.03
49	16.55	1.48	.60	1.69	.98

..... CONTINUED

APPENDIX A:  
 IN-LINE FORCE COEFFICIENTS FOR SMOOTH CYLINDERS  
 BETA = 2300 , k/D = 0

#	K	Cd	Cm	Cfmax	Carms
50	15.55	1.51	.61	1.85	1.01
51	13.48	1.35	.73	1.71	.91
52	13.49	1.33	.82	1.57	.90
53	20.42	1.21	1.08	1.70	.85
54	20.48	1.06	1.21	1.53	.78
55	21.91	1.11	1.19	1.51	.79
56	22.33	1.10	1.19	1.26	.77
57	22.34	1.07	1.38	1.16	.78
58	22.35	1.06	1.33	1.37	.78
59	22.70	1.07	1.06	1.26	.74
60	22.71	.99	1.37	1.13	.74
61	25.92	1.04	1.22	1.19	.72
62	25.98	.98	1.36	1.01	.70
63	30.15	.92	1.36	1.00	.65
64	30.20	.89	1.34	.96	.62
65	33.96	.83	1.50	.85	.59
66	34.02	.84	1.47	.90	.59
67	38.59	.80	1.50	.82	.56
68	38.62	.81	1.50	.82	.56
69	43.66	.79	1.48	.80	.53
70	43.74	.78	1.52	.78	.53
71	48.89	.75	1.49	.72	.50
72	48.92	.75	1.59	.81	.51
73	53.95	.70	1.50	.67	.47
74	54.04	.71	1.53	.74	.47
75	61.72	.68	1.52	.68	.45
76	61.77	.70	1.45	.70	.46
77	61.83	.69	1.55	.71	.45
78	61.92	.68	1.44	.66	.44
79	61.97	.69	1.54	.73	.45

THERE ARE 79 DATA PAIRS STORED AS (X,Y) IN FILES: ASDCD..ASDCM..ASDCF  
 .....and ASDCA

APPENDIX A:  
 IN-LINE FORCE COEFFICIENTS FOR SMOOTH CYLINDERS  
 BETA = 3435 , k/D = 0

#	K	Cd	Cm	Cfmax	Carms
1	.99	1.74	2.02	21.35	14.24
2	.99	1.93	2.02	21.15	14.26
3	1.00	1.78	2.02	20.98	14.14
4	1.00	1.83	2.02	21.20	14.17
5	1.38	1.28	2.02	15.31	10.23
6	1.38	1.26	2.03	15.34	10.25
7	1.39	1.27	2.02	15.08	10.19
8	1.39	1.27	2.02	15.09	10.20
9	1.85	1.04	2.00	11.16	7.55
10	1.85	.96	2.02	11.48	7.65
11	1.86	.94	2.01	11.44	7.58
12	2.16	.82	2.00	9.59	6.47
13	2.16	.85	2.00	9.52	6.46
14	2.17	.87	2.00	9.55	6.46
15	2.17	.94	2.00	9.66	6.48
16	2.69	.80	1.98	7.69	5.16
17	2.70	.79	1.98	7.69	5.15
18	2.70	.81	1.98	7.65	5.15
19	2.70	.86	1.98	7.61	5.15
20	3.13	.78	1.98	6.56	4.43
21	3.13	.82	1.98	6.69	4.44
22	3.32	.76	2.00	6.13	4.22
23	3.33	.85	1.99	6.10	4.20
24	3.94	.88	1.93	5.13	3.46
25	3.99	.86	1.93	5.07	3.41
26	4.01	.82	1.96	5.07	3.44
27	4.50	.87	1.90	4.44	3.00
28	4.50	.86	1.91	4.45	3.00
29	4.50	.87	1.91	4.46	3.00
30	5.33	.90	1.87	3.75	2.50
31	5.34	.93	1.86	3.75	2.50
32	5.34	.91	1.88	3.74	2.51
33	5.35	.91	1.87	3.73	2.50
34	6.23	.92	1.83	3.18	2.12
35	6.24	.91	1.84	3.16	2.13
36	6.25	.97	1.83	3.17	2.12
37	6.28	.92	1.83	3.14	2.11
38	7.12	1.01	1.77	2.72	1.84
39	7.13	.97	1.77	2.74	1.83
40	7.15	1.05	1.77	2.80	1.84
41	7.17	1.07	1.78	2.81	1.85
42	7.18	1.02	1.78	2.73	1.84
43	7.85	1.04	1.74	2.50	1.67
44	7.94	1.07	1.74	2.46	1.66
45	8.77	1.08	1.66	2.19	1.47
46	8.80	1.12	1.72	2.37	1.53
47	8.83	1.12	1.71	2.23	1.51
48	9.21	1.11	1.65	2.12	1.42
49	9.60	1.12	1.62	2.08	1.36

..... CONTINUED

APPENDIX A:  
 IN-LINE FORCE COEFFICIENTS FOR SMOOTH CYLINDERS  
 BETA = 3435 ,  $k/I = 0$

#	K	Cd	Cm	Cfmax	Carms
50	9.61	1.12	1.68	2.14	1.40
51	9.62	1.10	1.69	2.16	1.39
52	9.63	1.02	1.71	2.08	1.39
53	9.68	1.12	1.63	2.02	1.36
54	9.77	1.10	1.73	2.10	1.40
55	9.81	1.12	1.70	2.06	1.38
56	9.96	1.18	1.51	1.90	1.28
57	9.99	1.52	1.06	1.99	1.26
58	10.01	1.36	1.23	1.72	1.24
59	10.06	1.58	.98	2.07	1.26
60	10.10	1.56	.98	2.48	1.24
61	10.10	1.55	1.01	2.44	1.24
62	10.11	1.46	1.08	2.01	1.21
63	10.12	1.47	1.05	2.15	1.23
64	10.14	1.56	1.05	2.25	1.27
65	10.19	1.15	1.62	1.98	1.31
66	10.40	1.67	.80	2.07	1.23
67	10.41	1.58	.92	2.04	1.22
68	10.59	1.61	.83	2.46	1.21
69	10.61	1.67	.77	2.27	1.23
70	10.61	1.65	.86	2.51	1.25
71	10.62	1.68	.85	2.14	1.25
72	10.63	1.55	.91	2.38	1.19
73	11.03	1.68	.80	2.12	1.22
74	11.05	1.62	.81	2.56	1.20
75	11.05	1.59	.84	2.50	1.20
76	11.05	1.58	.89	2.50	1.20
77	11.06	1.70	.75	2.38	1.21
78	11.37	1.74	.65	2.31	1.21
79	11.90	1.71	.65	2.18	1.19
80	11.91	1.67	.73	2.42	1.18
81	12.69	1.66	.65	2.49	1.15
82	12.93	1.71	.66	2.05	1.15
83	12.94	1.61	.66	1.95	1.10
84	12.97	1.66	.65	2.33	1.14
85	12.98	1.59	.71	2.42	1.12
86	12.99	1.67	.59	2.34	1.14
87	14.06	1.58	.80	1.96	1.10
88	14.07	1.48	.73	1.74	1.02
89	14.11	1.54	.67	1.92	1.05
90	14.11	1.53	.73	1.92	1.06
91	15.03	1.39	.81	1.71	.98
92	15.03	1.32	.86	1.54	.94
93	15.04	1.42	.81	1.75	.99
94	15.71	1.35	.87	1.52	.95
95	15.73	1.29	.90	1.45	.91
96	15.73	1.29	.93	1.45	.92
97	15.74	1.29	.95	1.52	.93
98	15.75	1.23	.98	1.39	.89
99	16.56	1.24	.95	1.42	.89

..... CONTINUED

APPENDIX A:  
 IN-LINE FORCE COEFFICIENTS FOR SMOOTH CYLINDERS  
 BETA = 3435 , k/D = 0

<u>#</u>	<u>K</u>	<u>Cd</u>	<u>Cm</u>	<u>Cfmax</u>	<u>Carms</u>
100	16.56	1.23	.99	1.36	.89
101	16.60	1.17	1.05	1.23	.86
102	16.61	1.23	.98	1.42	.89
103	16.71	1.17	1.00	1.32	.86
104	17.50	1.14	1.03	1.24	.84
105	17.52	1.12	1.10	1.24	.83
106	17.59	1.15	1.08	1.26	.85
107	17.60	1.16	1.03	1.32	.85
108	17.82	.95	1.36	1.35	.80
109	17.91	.93	1.46	1.18	.80
110	17.96	.91	1.46	1.18	.79
111	17.96	.95	1.48	1.12	.82
112	17.98	.93	1.48	1.10	.81
113	18.53	.98	1.47	1.14	.82
114	18.60	.93	1.40	1.21	.78
115	18.61	.89	1.45	1.22	.77
116	18.62	.91	1.41	1.28	.77
117	18.63	.92	1.45	1.18	.78
118	19.66	.87	1.52	1.04	.75
119	19.68	.86	1.47	1.04	.74
120	19.89	.84	1.56	1.08	.75
121	22.43	.86	1.54	.97	.71
122	22.45	.80	1.55	.97	.68
123	22.57	.82	1.55	.95	.69
124	25.94	.78	1.56	.94	.63
125	25.97	.77	1.56	.89	.62
126	25.99	.76	1.64	.88	.64
127	26.06	.78	1.55	.91	.63
128	29.43	.73	1.61	.81	.58
129	29.43	.71	1.63	.81	.58
130	29.46	.73	1.61	.80	.58
131	33.39	.71	1.64	.76	.55
132	33.41	.71	1.64	.76	.55
133	33.62	.72	1.64	.76	.55
134	39.14	.68	1.63	.69	.51
135	39.18	.66	1.62	.71	.49
136	39.21	.67	1.63	.70	.50
137	45.14	.63	1.65	.65	.46
138	45.16	.64	1.64	.66	.46
139	45.19	.64	1.62	.65	.46
140	45.23	.64	1.65	.64	.46
141	51.23	.62	1.57	.62	.44
142	51.26	.63	1.51	.62	.44
143	51.28	.62	1.58	.62	.44

THERE ARE 143 DATA PAIRS STORED AS (X,Y) IN FILES: BSDCD..BSDCM..BSDCF  
 .....and BSDCA

APPENDIX A:  
 IN-LINE FORCE COEFFICIENTS FOR SMOOTH CYLINDERS  
 BETA = 4720 ,  $k_D = 0$

#	K	Cd	Cm	Cfmax	Carms
1	.89	1.44	2.06	23.51	15.09
2	.90	1.51	2.06	22.97	15.88
3	.93	1.23	2.04	22.57	15.33
4	.93	1.15	2.04	22.34	15.27
5	.95	1.19	2.03	22.09	14.89
6	1.14	1.24	2.07	18.38	12.65
7	1.14	1.25	2.07	18.46	12.63
8	1.14	1.27	2.07	18.38	12.65
9	1.15	1.29	2.07	18.50	12.59
10	1.39	1.04	2.07	15.04	10.41
11	1.39	1.03	2.07	15.16	10.42
12	1.39	.91	2.07	15.00	10.43
13	1.39	.98	2.07	15.01	10.41
14	1.53	.89	2.08	13.53	9.44
15	1.54	.85	2.07	13.59	9.41
16	1.54	.88	2.07	13.44	9.40
17	1.61	.95	2.05	12.77	8.90
18	1.82	.79	2.04	11.43	7.84
19	1.82	.82	2.04	11.38	7.84
20	2.21	.78	2.05	9.23	6.48
21	2.21	.76	2.04	9.25	6.46
22	2.85	.66	2.01	7.16	4.94
23	2.87	.63	2.01	7.12	4.90
24	2.87	.76	2.00	7.02	4.89
25	3.04	.72	2.01	6.64	4.63
26	3.06	.71	2.01	6.59	4.60
27	3.70	.69	2.00	5.43	3.79
28	3.70	.75	2.00	5.39	3.78
29	3.71	.77	1.99	5.40	3.78
30	4.06	.75	1.98	4.94	3.43
31	4.06	.77	1.98	4.89	3.43
32	4.31	.77	1.98	4.61	3.23
33	4.32	.73	1.98	4.59	3.22
34	4.95	.76	1.95	3.97	2.79
35	4.97	.78	1.94	3.99	2.77
36	4.98	.77	1.95	3.98	2.77
37	5.83	.85	1.90	3.38	2.33
38	5.85	.79	1.91	3.36	2.32
39	5.99	.83	1.89	3.31	2.26
40	6.01	.83	1.89	3.30	2.25
41	6.70	.88	1.87	2.97	2.02
42	6.78	.92	1.84	2.89	1.97
43	7.21	.93	1.83	2.76	1.86
44	7.23	.98	1.82	2.78	1.85
45	7.58	.93	1.82	2.65	1.77
46	7.82	.87	1.80	2.52	1.69
47	7.97	.96	1.79	2.48	1.67
48	7.98	.89	1.83	2.47	1.69
49	8.93	.96	1.77	2.21	1.50

..... CONTINUED

APPENDIX A:  
 IN-LINE FORCE COEFFICIENTS FOR SMOOTH CYLINDERS  
 BETA = 4720 , k/D = 0

<u>#</u>	<u>K</u>	<u>Cd</u>	<u>Cm</u>	<u>Cfmax</u>	<u>Carms</u>
50	8.94	.92	1.71	2.17	1.45
51	9.28	1.10	1.64	2.19	1.40
52	9.32	1.04	1.71	2.13	1.43
53	9.32	.96	1.70	2.11	1.40
54	9.34	.91	1.78	2.08	1.44
55	9.48	1.03	1.69	2.09	1.39
56	9.48	.99	1.70	2.06	1.39
57	9.55	.98	1.51	1.87	1.28
58	9.55	1.10	1.44	1.83	1.29
59	9.62	.99	1.68	2.00	1.36
60	9.79	1.11	1.39	1.79	1.24
61	9.79	1.12	1.38	1.76	1.24
62	9.80	1.05	1.46	1.80	1.25
63	9.95	1.17	1.34	1.74	1.22
64	9.95	1.35	1.17	1.81	1.22
65	9.96	1.22	1.30	1.70	1.22
66	10.01	1.35	1.18	1.69	1.22
67	10.31	1.30	1.16	1.79	1.18
68	10.49	1.42	1.04	1.86	1.19
69	10.49	1.38	1.00	2.22	1.15
70	10.49	1.40	1.04	2.16	1.18
71	11.02	1.48	.88	1.99	1.14
72	11.08	1.42	.98	1.88	1.13
73	11.08	1.44	.90	2.09	1.12
74	11.21	1.58	.86	2.13	1.14
75	11.25	1.53	.80	1.96	1.13
76	11.28	1.54	.81	2.05	1.14
77	11.68	1.48	.85	1.84	1.10
78	11.72	1.42	.95	2.15	1.11
79	11.75	1.46	.89	1.82	1.10
80	12.02	1.36	.93	1.75	1.04
81	12.02	1.37	.91	1.58	1.04
82	12.21	1.50	.80	1.94	1.09
83	12.25	1.39	.92	1.73	1.05
84	12.29	1.45	.86	1.73	1.07
85	12.76	1.35	.92	1.74	1.01
86	12.76	1.43	.81	1.63	1.02
87	12.77	1.30	1.02	1.79	1.02
88	13.33	1.36	.93	1.64	1.01
89	13.38	1.33	.95	1.69	1.00
90	13.41	1.24	1.03	1.40	.97
91	13.98	1.21	1.00	1.35	.92
92	13.99	1.09	1.18	1.30	.91
93	14.03	1.16	1.15	1.26	.93
94	14.04	1.14	1.20	1.37	.95
95	14.14	1.06	1.24	1.22	.91
96	14.58	1.06	1.23	1.22	.90
97	14.62	1.04	1.23	1.13	.88
98	14.64	1.08	1.19	1.19	.89
99	14.76	.84	1.64	1.32	.93

..... CONTINUED

APPENDIX A:  
 IN-LINE FORCE COEFFICIENTS FOR SMOOTH CYLINDERS  
 BETA = 4720 ,  $k/D = 0$

#	K	Cd	Cm	Cfmax	Carms
100	15.15	1.00	1.33	1.20	.88
101	15.18	1.00	1.32	1.18	.88
102	15.23	.77	1.66	1.26	.90
103	15.23	.78	1.74	1.32	.93
104	15.83	.78	1.64	1.24	.87
105	15.84	.74	1.68	1.22	.87
106	15.86	.79	1.62	1.20	.86
107	16.51	.81	1.64	1.21	.85
108	16.52	.79	1.70	1.24	.86
109	16.66	.77	1.70	1.21	.85
110	16.72	.76	1.70	1.22	.85
111	17.89	.70	1.76	1.17	.81
112	18.03	.74	1.69	1.13	.79
113	20.95	.66	1.68	.98	.69
114	20.95	.68	1.70	1.01	.70
115	22.32	.64	1.72	.90	.66
116	22.32	.66	1.76	.99	.68
117	22.32	.65	1.74	.96	.67
118	24.08	.64	1.74	.91	.64
119	24.08	.66	1.74	.95	.64
120	26.04	.64	1.76	.89	.61
121	26.04	.62	1.77	.87	.61
122	26.04	.66	1.75	.86	.62
123	29.37	.63	1.76	.80	.57
124	29.37	.63	1.75	.79	.56
125	34.18	.61	1.77	.72	.51
126	35.83	.59	1.78	.70	.50
127	35.87	.60	1.77	.69	.50
128	40.98	.59	1.80	.67	.47
129	41.05	.58	1.80	.65	.47
130	45.58	.57	1.85	.67	.44
131	45.66	.57	1.86	.65	.44

THERE ARE 131 DATA PAIRS STORED AS (X,Y) IN FILES: CSDCD..CSDCM..CSDCF  
 .....and CSDCA

APPENDIX A:  
 IN-LINE FORCE COEFFICIENTS FOR SMOOTH CYLINDERS  
 BETA = 6555 , k/D = 0

#	K	Cd	Cm	Cfmax	Carms
1	1.03	1.53	2.01	20.24	13.65
2	1.03	1.51	2.02	20.82	13.77
3	1.25	1.34	2.02	16.80	11.31
4	1.25	1.04	2.02	16.91	11.29
5	1.25	1.04	2.02	17.07	11.30
6	1.25	1.11	2.01	16.96	11.29
7	1.61	.86	2.02	12.96	8.74
8	1.62	.89	2.01	12.97	8.71
9	2.32	.72	2.00	8.92	6.03
10	2.33	.69	2.00	8.95	6.02
11	2.72	.74	2.00	7.58	5.13
12	2.73	.74	1.99	7.58	5.12
13	2.77	.74	1.99	7.47	5.03
14	3.22	.67	1.98	6.35	4.30
15	3.27	.69	1.98	6.27	4.24
16	3.66	.69	1.97	5.55	3.77
17	3.68	.68	1.97	5.54	3.75
18	4.58	.69	1.95	4.38	3.00
19	5.69	.74	1.90	3.50	2.37
20	5.72	.73	1.90	3.46	2.36
21	6.29	.73	1.88	3.13	2.13
22	7.76	.86	1.80	2.53	1.70
23	8.55	.88	1.80	2.31	1.56
24	8.55	.77	1.82	2.29	1.56
25	9.26	.88	1.79	2.18	1.45
26	9.26	.90	1.77	2.15	1.44
27	9.26	.83	1.80	2.13	1.44
28	9.60	.96	1.72	2.07	1.38
29	9.66	.84	1.77	2.02	1.38
30	10.18	1.14	1.22	1.67	1.14
31	10.24	1.00	1.38	1.73	1.15
32	10.25	1.02	1.37	1.69	1.16
33	10.89	1.16	1.15	1.53	1.07
34	10.90	1.22	1.13	1.85	1.10
35	11.43	1.27	.99	1.63	1.04
36	11.52	1.24	.98	1.46	1.00
37	11.52	1.30	.97	1.70	1.05
38	11.56	1.20	1.09	1.38	1.03
39	11.57	1.20	1.05	1.46	1.01
40	12.59	1.15	1.07	1.38	.96
41	12.59	1.04	1.29	1.42	.99
42	13.15	.89	1.43	1.38	.95
43	13.15	1.01	1.27	1.33	.94
44	14.46	.80	1.50	1.27	.88
45	14.51	.81	1.49	1.25	.87
46	15.88	.78	1.63	1.23	.86
47	15.90	.72	1.73	1.25	.87
48	18.02	.71	1.69	1.12	.78
49	18.05	.71	1.71	1.17	.79

..... CONTINUED

APPENDIX A:  
 IN-LINE FORCE COEFFICIENTS FOR SMOOTH CYLINDERS  
 BETA = 6555 ,  $k/D = 0$

<u>#</u>	<u>K</u>	<u>Cd</u>	<u>Cm</u>	<u>Cfmax</u>	<u>Carms</u>
50	20.43	.67	1.74	1.04	.72
51	20.45	.67	1.74	1.05	.72
52	23.28	.66	1.72	.93	.65
53	26.83	.65	1.72	.84	.60
54	29.78	.62	1.74	.76	.56
55	32.10	.62	1.73	.73	.53
56	34.65	.60	1.76	.71	.51
57	34.65	.60	1.78	.71	.51
58	36.91	.58	1.82	.71	.49
59	36.97	.59	1.79	.68	.49
60	37.06	.62	1.78	.72	.50
61	37.09	.61	1.79	.72	.50
62	37.11	.59	1.80	.71	.42

THERE ARE 62 DATA PAIRS STORED AS (X,Y) IN FILES: DSDCD..DSDCM..DSDCF  
 .....and DSDCA

APPENDIX A:  
 IN-LINE FORCE COEFFICIENTS FOR SMOOTH CYLINDERS  
 BETA = 11525 , k/D = 0

#	K	Cd	Cm	Cfmax	Carms
1	.83	1.54	2.04	25.32	17.15
2	.83	1.42	2.04	25.21	17.09
3	1.10	1.22	2.04	18.82	12.91
4	1.13	1.05	2.04	18.61	12.62
5	1.13	1.09	2.04	18.56	12.61
6	1.41	1.00	2.04	15.01	10.14
7	1.46	.97	2.04	14.43	9.76
8	1.56	.72	2.03	13.32	9.10
9	1.56	.72	2.04	13.44	9.14
10	1.57	.91	2.04	13.23	9.06
11	2.11	.68	2.03	9.80	6.72
12	2.12	.61	2.04	9.77	6.72
13	2.52	.61	2.03	8.15	5.61
14	2.54	.58	2.03	8.08	5.58
15	2.99	.59	2.01	6.84	4.71
16	2.99	.53	2.01	6.83	4.70
17	3.00	.58	2.01	6.82	4.68
18	3.54	.61	2.00	5.71	3.92
19	3.56	.57	1.99	5.64	3.90
20	3.56	.63	1.99	5.63	3.91
21	4.19	.56	1.98	4.77	3.31
22	4.21	.62	1.98	4.74	3.29
23	5.01	.58	1.95	3.92	2.74
24	5.03	.58	1.95	3.91	2.73
25	6.13	.62	1.92	3.15	2.22
26	6.14	.64	1.92	3.17	2.21
27	7.68	.77	1.87	2.55	1.76
28	7.67	.70	1.88	2.54	1.76
29	9.23	.73	1.82	2.11	1.44
30	9.23	.79	1.81	2.16	1.45
31	9.77	.77	1.65	1.91	1.28
32	9.78	.82	1.62	1.87	1.27
33	10.86	.85	1.46	1.61	1.09
34	10.86	.84	1.47	1.62	1.09
35	10.86	.83	1.44	1.59	1.07
36	10.86	.87	1.44	1.62	1.08
37	11.74	.87	1.36	1.44	.99
38	11.74	.86	1.41	1.47	1.00
39	11.80	.87	1.42	1.49	1.01
40	12.20	.86	1.45	1.44	.99
41	12.20	.85	1.44	1.45	.99
42	12.43	.82	1.46	1.42	.97
43	12.71	.82	1.46	1.39	.96
44	12.96	.79	1.48	1.39	.94
45	13.27	.75	1.52	1.37	.93
46	13.29	.71	1.75	1.49	1.02
47	13.30	.67	1.79	1.49	1.02
48	13.30	.67	1.75	1.47	1.00
49	13.34	.70	1.58	1.38	.94

..... CONTINUED

APPENDIX A:  
 IN-LINE FORCE COEFFICIENTS FOR SMOOTH CYLINDERS  
 BETA = 11525 ,  $k/D = 0$

<u>n</u>	<u>K</u>	<u>Cd</u>	<u>Cm</u>	<u>Cfmax</u>	<u>Carms</u>
50	15.81	.70	1.68	1.25	.85
51	15.81	.71	1.63	1.20	.84
52	20.85	.66	1.70	1.01	.69
53	20.87	.66	1.68	1.00	.69
54	26.62	.63	1.71	.82	.59
55	31.14	.62	1.70	.75	.54
56	31.19	.62	1.71	.74	.54
57	35.18	.61	1.75	.70	.51
58	35.21	.61	1.75	.71	.51
59	36.84	.60	1.74	.70	.49
60	36.96	.60	1.79	.71	.50

THERE ARE 60 DATA PAIRS STORED AS (X,Y) IN FILES: DSDHCD..DSDHCM..DSDHCF  
 .....and DSDHCA

APPENDIX B:  
 RMS VALUE OF THE LIFT FORCE FOR SMOOTH CYLINDERS  
 $\text{BETA} = 2300$  ,  $k/D = 0$

<u>#</u>	<u>K</u>	<u>C/rms</u>	<u>#</u>	<u>K</u>	<u>C/rms</u>
1	4.953	.179	2	6.684	.385
3	6.684	.393	4	8.191	.71
5	8.191	.745	6	9.599	.791
7	9.621	.93	8	11.661	1.568
9	11.661	1.571	10	11.911	1.627
11	13.538	1.336	12	13.538	1.434
13	14.914	1.041	14	15.221	1.095
15	15.227	1.102	16	15.25	1.056
17	17.184	.843	18	17.235	.782
19	18.1	.748	20	18.105	.741
21	18.139	.744	22	19.362	.697
23	19.368	.769	24	21.365	.65
25	21.387	.642	26	25.838	.51
27	25.909	.454	28	30.858	.297
29	30.858	.391	30	32.565	.278
31	32.579	.329	32	35.864	.28
33	38.466	.285	34	38.495	.259
35	42.803	.199	36	42.832	.211
37	47.652	.192	38	47.752	.189
39	52.416	.16	40	52.487	.136
41	63.138	.124	42	63.167	.122

THERE ARE 42 DATA PAIRS STORED AS (X,Y) IN FILE NO: ASLCL

APPENDIX B:  
 RME VALUE OF THE LIFT FORCE FOR SMOOTH CYLINDERS  
 $\beta R = 3435$  ,  $k/D = 0$

#	K	Clrms	#	K	Clrms
1	3.937	.241	2	3.939	.279
3	4.62	.225	4	4.974	.24
5	5.027	.269	6	5.034	.255
7	5.734	.271	8	5.743	.295
9	7.042	.282	10	7.077	.326
11	8.008	.343	12	8.063	.385
13	8.107	.512	14	8.638	.511
15	8.665	.263	16	9.462	.712
17	9.615	.626	18	9.828	1.597
19	10.008	1.504	20	10.462	1.643
21	10.518	1.614	22	10.736	1.617
23	10.759	1.612	24	10.976	1.651
25	11	1.574	26	11.426	1.611
27	11.435	1.562	28	11.921	1.49
29	11.968	1.545	30	12.426	1.424
31	12.458	1.49	32	13.102	1.407
33	13.112	1.342	34	13.575	1.286
35	13.639	1.232	36	14.084	1.26
37	14.107	1.205	38	14.783	1.06
39	14.788	1.122	40	15.395	.95
41	15.423	.993	42	16.441	.832
43	16.451	.85	44	17.321	.756
45	17.326	.717	46	17.442	.714
47	17.484	.706	48	18.382	.64
49	18.563	.71	50	18.572	.73
51	18.618	.748	52	19.683	.63
53	19.718	.658	54	19.741	.657
55	22.184	.397	56	22.231	.449
57	23.331	.291	58	25.809	.353
59	28.599	.23	60	28.715	.197
61	33.578	.167	62	33.578	.173
63	38.788	.147	64	38.846	.153
65	44.612	.132	66	44.739	.125
67	48.167	.132	68	50.864	.127
69	50.934	.126	70	51.536	.116
71	51.629	.119	72	0	0

THERE ARE 71 DATA PAIRS STORED AS (X,Y) IN FILE NO: BSLCL

APPENDIX B:

RMS VALUE OF THE LIFT FORCE FOR SMOOTH CYLINDERS

BETA = 3435 , k/D = 0

<u>#</u>	<u>K</u>	<u>Cm</u>	<u>#</u>	<u>K</u>	<u>Cm</u>
101	31.648	.169	102	34.105	.136
103	34.849	.128	104	34.986	.132
105	37.022	.143	106	37.041	.142
107	38.989	.146	108	38.999	.125
109	39.038	.123	110	40.311	.117
111	43.365	.124	112	43.463	.115
113	43.551	.129	114	0	0

THERE ARE 113 DATA PAIRS STORED AS (X,Y) IN FILE NO: CSLCL

APPENDIX B:  
 RMS VALUE OF THE LIFT FORCE FOR SMOOTH CYLINDERS  
 $BETA = 4720$  ,  $K/D = 0$

#	K	Clrms	#	K	Clrms
1	5.364	.362	2	5.388	.344
3	5.848	.321	4	5.873	.321
5	6.472	.401	6	6.563	.361
7	6.774	.335	8	7.569	.345
9	7.569	.357	10	7.588	.411
11	8.642	.508	12	8.659	.469
13	9.319	.445	14	9.319	.541
15	9.35	.46	16	9.354	.404
17	9.48	.509	18	9.48	.4
19	9.503	1.032	20	9.711	.575
21	9.781	.491	22	9.82	1.154
23	9.84	1.311	24	9.867	1.154
25	9.883	.572	26	10.106	1.424
27	10.165	1.44	28	10.184	1.39
29	10.208	1.399	30	10.627	1.489
31	10.29	1.416	32	10.349	1.449
33	10.376	1.498	34	10.572	1.499
35	11.183	1.486	36	11.195	1.48
37	11.672	1.386	38	11.676	1.382
39	11.747	1.361	40	11.751	1.428
41	12.166	1.398	42	12.604	1.291
43	12.607	1.326	44	12.628	1.204
45	12.647	1.367	46	12.655	1.224
47	12.659	1.294	48	13.203	1.062
49	13.274	1.024	50	13.536	1.12
51	13.556	1.006	52	13.618	.9
53	14.139	.844	54	14.163	.521
55	14.17	.611	56	14.174	.898
57	14.593	.449	58	14.605	.509
59	14.609	.619	60	14.785	.724
61	14.813	.676	62	14.864	.718
63	15.392	.509	64	15.396	.672
65	15.427	.498	66	15.463	.63
67	15.584	.58	68	15.592	.5
69	15.6	.332	70	15.623	.462
71	16.05	.456	72	16.054	.414
73	16.054	.478	74	16.242	.332
75	16.254	.442	76	16.257	.349
77	16.755	.401	78	16.798	.487
79	16.837	.349	80	16.876	.521
81	16.904	.365	82	16.907	.345
83	18.376	.298	84	18.511	.372
85	18.599	.331	86	20.547	.336
87	20.557	.386	88	21.869	.2
89	21.917	.292	90	21.937	.298
91	22.338	.24	92	22.338	.221
93	24.51	.194	94	24.57	.18
95	26.626	.198	96	26.636	.2
97	26.646	.179	98	31.364	.161
99	31.511	.182	100	31.589	.162

CONTINUED

APPENDIX B:  
 RMS VALUE OF THE LIFT FORCE FOR SMOOTH CYLINDERS  
 BETA = 6555 ,  $k/D = 0$

<u>#</u>	<u>K</u>	<u>Clrms</u>	<u>#</u>	<u>K</u>	<u>Clrms</u>
1	5.09	.124	2	5.13	.125
3	5.98	.144	4	6.08	.166
5	6.65	.184	6	6.73	.16
7	6.73	.22	8	7.72	.43
9	7.73	.254	10	7.74	.322
11	8.35	.405	12	8.36	.337
13	9.11	.497	14	9.11	.593
15	9.12	.337	16	9.5	.411
17	9.5	1.042	18	9.5	.757
19	10.25	1.278	20	10.26	1.212
21	10.95	1.403	22	11	1.331
23	12.28	1.1	24	12.29	1.123
25	12.31	.998	26	13.55	.781
27	13.57	.7	28	13.59	.711
29	14.2	.621	30	14.2	.56
31	14.21	.502	32	14.89	.34
33	14.89	.41	34	14.89	.313
35	15.78	.488	36	15.83	.414
37	17	.35	38	17.01	.291
39	17.35	.409	40	17.37	.318
41	17.39	.223	42	19.91	.298
43	19.92	.301	44	20.03	.23
45	23.42	.212	46	23.42	.172
47	28.85	.171	48	28.86	.196
49	33.79	.201	50	33.82	.158
51	34.36	.177	52	34.42	.159

THERE ARE 52 DATA PAIRS STORED AS (X,Y) IN FILE NO: DSLCL

APPENDIX C:  
HARMONICS OF THE LIFT FORCE FOR SMOOTH CYLINDERS  
ETA = 2300 , k/D = 0

<u>F</u>	<u>CL(1)</u>	<u>CL(2)</u>	<u>CL(3)</u>	<u>CL(4)</u>	<u>CL(5)</u>
4.953	.092	.088	.003	.023	.005
6.684	.074	.207	.065	.062	.017
6.684	.102	.334	.09	.056	.012
8.191	.061	.504	.046	.107	.006
8.191	.065	.775	.055	.099	.013
9.599	.033	.271	.029	.08	.007
9.521	.068	.488	.065	.132	.018
11.651	.549	1.889	.333	.467	.082
11.651	.407	1.959	.172	.441	.106
11.911	.221	2.025	.247	.464	.089
13.538	.287	1.558	.315	.53	.021
13.538	.278	1.725	.243	.536	.093
14.914	.085	1.206	.216	.602	.06
15.221	.08	1.3	.119	.567	.044
15.227	.075	1.218	.098	.603	.031
15.25	.118	1.135	.249	.592	.022
17.134	.025	.857	.068	.506	.037
17.235	.054	.657	.274	.488	.16
18.1	.061	.694	.13	.517	.051
18.105	.089	.659	.195	.475	.1
18.139	.082	.65	.133	.522	.078
19.362	.113	.449	.49	.376	.179
21.365	.135	.057	.61	.149	.302
21.337	.059	.081	.591	.112	.278
25.838	.028	.099	.202	.277	.217
25.909	.037	.105	.105	.407	.122
30.353	.026	.012	.018	.094	.138
30.353	.014	.039	.018	.074	.096
32.555	.003	.013	.03	.045	.086
32.579	.031	.027	.028	.073	.191
35.854	.016	.028	.031	.051	.061
38.455	.012	.033	.031	.024	.082
38.495	.013	.039	.03	.02	.042
42.803	.033	.011	.008	.046	.03
42.832	.02	.033	.024	.007	.007
47.652	.01	.044	.018	.055	.003
47.752	.03	.016	.023	.023	.023
52.416	.015	.046	.026	.037	.024
52.437	.024	.034	.035	.032	.014
53.138	.033	.038	.013	.031	.021
53.157	.036	.031	.022	.027	.004

THERE ARE 41 SINGLE POINTS IN FILES: ...ASLHK...ASCL1  
...ASCL2...ASCL3...ASCL4...ASCL5

APPENDIX C:  
HARMONICS OF THE LIFT FORCE FOR SMOOTH CYLINDERS  
 $\beta = 2300$  ,  $k/D = 0$

<u>f</u>	<u>CL(6)</u>	<u>CL(7)</u>	<u>CL(8)</u>	<u>CL(9)</u>	<u>CL(10)</u>
4.953	.003	.002	.002	.001	.001
6.684	.013	.003	.003	.001	0
6.684	.009	.002	.002	.002	.001
8.191	.008	.011	.001	.006	.001
8.191	.011	.007	.011	.006	.003
9.599	.019	.004	.013	.005	.003
9.621	.024	.017	.006	.001	.003
11.661	.059	.032	.021	.008	.007
11.661	.061	.029	.018	.006	.007
11.911	.048	.041	.011	.019	.009
13.538	.086	.031	.011	.009	.001
13.538	.086	.068	.016	.032	.011
14.914	.089	.017	.006	.007	.01
15.221	.084	.023	.008	.003	.001
15.227	.078	.029	.011	.019	.008
15.25	.067	.024	.013	.009	.008
17.134	.063	.012	.003	.006	.004
17.235	.092	.056	.021	.009	.012
18.1	.089	.022	.024	.01	.007
18.105	.087	.028	.012	.006	.004
18.139	.074	.029	.017	.016	.007
19.362	.037	.01	.026	.004	.016
21.365	.075	.067	.03	.012	.016
21.387	.056	.072	.013	.017	.014
25.838	.109	.089	.02	.032	.014
25.909	.186	.05	.043	.008	.008
30.858	.051	.075	.032	.014	.02
30.858	.056	.091	.026	.037	.021
32.565	.044	.037	.034	.009	.019
32.579	.121	.122	.051	.007	.005
35.864	.067	.057	.025	.025	.039
38.466	.096	.048	.1	.005	.031
38.495	.061	.041	.078	.036	.032
42.803	.01	.058	.005	.045	.019
42.832	.023	.007	.028	.005	.016
47.652	.011	.022	.008	.015	.028
47.752	.049	.003	.039	.021	.012
52.416	.019	.021	.031	.029	.021
52.437	.012	.027	.024	.026	.016
63.138	.016	.017	.01	.023	.019
63.167	.001	.021	.016	.01	.016

THERE ARE 41 SINGLE POINTS IN FILES: ...ASLHK...ASCL6  
...ASCL7...ASCL8...ASCL9...ASCL10

APPENDIX C:  
HARMONICS OF THE LIFT FORCE FOR SMOOTH CYLINDERS  
 $\beta/\alpha = 3435$  ,  $k/D = 0$

<u>F</u>	<u>CL(1)</u>	<u>CL(2)</u>	<u>CL(3)</u>	<u>CL(4)</u>	<u>CL(5)</u>
3.937	.084	.015	.011	.005	.001
3.939	.115	.013	.017	.003	.001
4.82	.084	.028	.006	.003	.003
4.874	.077	.023	.01	.001	.002
5.027	.054	.059	.004	.004	.003
5.034	.088	.061	.019	.007	.003
5.734	.07	.051	.007	.005	.002
5.743	.095	.152	.038	.018	.01
7.042	.016	.216	.044	.044	.007
7.077	.007	.319	.096	.043	.022
8.003	.085	.374	.083	.077	.019
8.063	.018	.434	.016	.107	.003
8.107	.089	.541	.094	.092	.025
8.633	.045	.653	.029	.128	.01
8.665	.054	.069	.065	.029	.017
9.462	.046	.764	.161	.148	.039
9.615	.02	.511	.114	.11	.034
9.823	.021	2.14	.061	.565	.012
10.008	.112	2.049	.211	.457	.127
10.462	.119	2.223	.154	.538	.073
10.518	.349	2.126	.353	.517	.153
10.736	.139	2.226	.096	.544	.051
10.759	.275	2.144	.28	.532	.126
10.976	.043	2.236	.058	.554	.015
11	.303	2.113	.324	.488	.134
11.426	.314	2.145	.149	.557	.098
11.435	.049	2.043	.077	.545	.054
11.921	.264	1.964	.123	.579	.081
11.968	.151	2.091	.066	.554	.051
12.435	.128	1.888	.065	.585	.055
12.513	.129	1.945	.158	.54	.064
13.165	.097	1.803	.123	.585	.017
13.112	.123	1.762	.165	.561	.044
13.639	.015	1.672	.01	.543	.02
13.704	.118	1.544	.143	.593	.031
14.151	.04	1.458	.019	.541	.013
14.174	.093	1.387	.164	.508	.036
14.354	.109	1.208	.104	.531	.023
14.359	.031	1.267	.121	.521	.024
15.463	.057	.989	.098	.527	.027
15.496	.009	1.063	.197	.546	.041
16.441	.055	.834	.072	.528	.023
16.529	.014	.856	.107	.57	.018
17.321	.047	.712	.048	.484	.034
17.326	.051	.705	.072	.444	.021

CONTINUED

APPENDIX C:  
 HARMONICS OF THE LIFT FORCE FOR SMOOTH CYLINDERS  
 BETA = 3435 , k/D = 0

<u>f</u>	<u>CL&lt;1&gt;</u>	<u>CL&lt;2&gt;</u>	<u>CL&lt;3&gt;</u>	<u>CL&lt;4&gt;</u>	<u>CL&lt;5&gt;</u>
17.442	.097	.648	.141	.506	.085
17.484	.019	.617	.348	.426	.156
18.382	.084	.534	.224	.451	.07
18.563	.08	.201	.747	.147	.39
18.572	.064	.039	.799	.047	.418
18.618	.15	.463	.619	.327	.254
19.533	.027	.043	.292	.429	.154
19.718	.039	.061	.668	.015	.308
19.741	.084	.091	.655	.276	.357
22.134	.056	.028	.147	.175	.091
22.231	.039	.088	.076	.015	.034
23.331	.04	.026	.08	.039	.033
25.889	.004	.052	.126	.299	.136
28.599	.044	.023	.064	.094	.062
28.715	.026	.038	.031	.03	.12
33.578	.015	.034	.028	.024	.048
33.578	.012	.043	.025	.037	.031
38.738	.013	.035	.022	.021	.052
38.846	.02	.053	.019	.035	.029
44.612	.005	.042	.011	.021	.019
44.739	.015	.041	.013	.005	.01
48.157	.015	.043	.013	.028	.025
50.854	.017	.058	.013	.034	.017
50.934	.017	.044	.018	.032	.025
51.536	.006	.039	.009	.031	.008
51.629	.004	.053	.014	.03	.024

THERE ARE 71 SINGLE POINTS IN FILES:...BSLHK...BSCL1  
 ...BSCL2...BSCL3...BSCL4...BSCL5

APPENDIX C:  
HARMONICS OF THE LIFT FORCE FOR SMOOTH CYLINDERS  
 $\text{ITER} = 3435$ ,  $k/D = 0$

	CL(6)	CL(7)	CL(8)	CL(9)	CL(10)
3.937	.001	.003	.004	.002	.002
3.939	.002	.003	.003	0	.001
4.62	.002	.003	.001	.001	.001
4.974	.002	0	.002	.002	.001
5.027	.001	.002	0	0	.001
5.234	.003	.001	.002	.001	.001
5.734	.002	.002	.002	.001	.001
5.743	.004	.002	.001	.001	.001
7.042	.004	.003	.002	.003	.001
7.077	.005	.003	0	.001	.001
8.003	.015	.004	.005	.002	.003
8.051	.013	.002	.003	.001	.002
8.107	.009	.008	.006	.003	.003
8.533	.016	.002	.008	.001	.001
8.655	.005	.006	.003	.001	.004
8.452	.025	.01	.011	.006	.003
9.615	.015	.001	.002	.003	.002
9.823	.145	.014	.047	.005	.015
10.033	.077	.057	.02	.017	.006
10.452	.124	.033	.031	.01	.007
10.513	.122	.064	.041	.027	.016
10.736	.11	.025	.029	.005	.01
10.753	.111	.054	.03	.02	.01
10.975	.13	.014	.033	.006	.007
11	.095	.049	.024	.014	.011
11.426	.119	.046	.036	.018	.012
11.435	.114	.031	.034	.018	.014
11.921	.115	.036	.031	.015	.011
11.953	.117	.022	.027	.01	.007
12.435	.11	.034	.029	.013	.009
12.513	.109	.028	.026	.01	.01
13.155	.111	.023	.024	.009	.007
13.112	.099	.029	.023	.016	.004
13.639	.096	.006	.023	.002	.004
13.734	.104	.015	.025	.009	.01
14.151	.089	.005	.012	.005	.004
14.174	.079	.015	.004	.006	.004
14.354	.068	.009	.008	.006	.007
14.359	.079	.005	.011	.004	.006
15.458	.071	.013	.019	.005	.007
15.436	.084	.015	.017	.013	.009
16.441	.091	.01	.013	.003	.01
16.529	.125	.004	.015	.002	.008
17.321	.101	.019	.031	.008	.016
17.325	.099	.014	.021	.002	.013

..... CONTINUED

APPENDIX C:  
HARMONICS OF THE LIFT FORCE FOR SMOOTH CYLINDERS  
ETA = 3435 , k/D = 0

<u>f</u>	<u>CL(6)</u>	<u>CL(7)</u>	<u>CL(8)</u>	<u>CL(9)</u>	<u>CL(10)</u>
17.442	.086	.02	.016	.011	.008
17.434	.074	.015	.032	.004	.017
18.332	.112	.006	.02	.007	.01
18.553	.044	.107	.019	.034	.012
18.572	.011	.129	.009	.056	.009
18.618	.086	.047	.016	.009	.009
19.633	.23	.027	.063	.005	.01
19.718	.019	.051	.005	.011	.005
19.741	.137	.094	.05	.021	.017
22.134	.063	.034	.013	.015	.007
22.231	.022	.011	.018	.011	.005
23.331	.062	.029	.03	.013	.007
25.309	.131	.063	.02	.007	.005
28.599	.035	.069	.018	.038	.022
28.715	.017	.096	.009	.028	.007
33.578	.042	.025	.033	.006	.008
33.578	.032	.033	.003	.017	.014
38.738	.006	.022	.004	.02	.008
38.846	.027	.016	.011	.01	.028
44.612	.01	.007	.012	.025	.008
44.739	.016	.011	.011	.01	.02
48.157	.015	.015	.005	.013	.006
50.854	.012	.013	.021	.007	.017
50.934	.006	.012	.012	.013	.01
51.536	.012	.005	.017	.005	.011
51.629	.021	.015	.02	.016	.01

THERE ARE 71 SINGLE POINTS IN FILES:...BSLHK...BSCL6  
...BSCL7...BSCL8...BSCL9...BSCL10

APPENDIX C:  
HARMONICS OF THE LIFT FORCE FOR SMOOTH CYLINDERS  
BETA = 4720 ,  $k^2 D = 0$

<u>F</u>	<u>CL(1)</u>	<u>CL(2)</u>	<u>CL(3)</u>	<u>CL(4)</u>	<u>CL(5)</u>
7.569	.031	.347	.047	.055	.015
8.659	.045	.469	.035	.11	.001
9.119	.033	.229	.237	.083	.056
9.84	.041	1.734	.099	.548	.071
9.781	.062	.441	.095	.099	.024
9.71	.037	.29	.105	.063	.021
10.106	.079	.965	.055	.237	.037
11.133	.06	.999	.021	.224	.008
11.195	.079	.967	.036	.233	.02
11.672	.064	.897	.088	.234	.036
12.604	.096	1.729	.079	.469	.017
13.536	.077	.705	.099	.212	.037
13.556	.035	.629	.014	.219	.011
13.618	.069	.527	.066	.222	.02
14.813	.064	.352	.05	.227	.027
15.592	.034	.012	.276	.013	.131
16.054	.026	.059	.206	.08	.096
18.511	.042	.021	.174	.083	.067
22.338	.026	.035	.095	.106	.109
24.57	.04	.008	.072	.049	.052
31.539	.021	.016	.016	.04	.028
37.022	.022	.032	.02	.031	.037

THERE ARE 22 SINGLE POINTS IN FILES: ...CSLHK...CSCL1  
...CSCL2...CSCL3...CSCL4...CSCL5

APPENDIX C:  
HARMONICS OF THE LIFT FORCE FOR SMOOTH CYLINDERS  
ETA = 4720 , k/D = 0

<u>F</u>	<u>CL(6)</u>	<u>CL(7)</u>	<u>CL(8)</u>	<u>CL(9)</u>	<u>CL(10)</u>
7.569	.009	.005	.003	0	0
8.859	.016	.001	.005	.003	.001
9.119	.02	.013	.002	.004	.001
9.84	.136	.041	.043	.023	.011
9.781	.006	.007	.003	.006	.002
9.71	.013	.01	.006	.004	.001
10.106	.048	.016	.011	.007	.003
11.133	.05	.006	.013	.003	.003
11.135	.048	.008	.012	.005	.005
11.672	.046	.01	.008	.003	.001
12.604	.087	.008	.014	.002	.004
13.536	.033	.01	.002	.002	.002
13.556	.032	.006	.004	.003	.002
13.618	.038	.007	.003	.003	.001
14.813	.05	.001	.006	.002	.002
15.592	.015	.035	.008	.009	.005
16.054	.036	.028	.01	.008	.005
18.511	.036	.018	.014	.02	.006
22.338	.06	.07	.018	.025	.003
24.57	.057	.043	.041	.014	.015
31.539	.016	.059	.016	.047	.004
37.022	.047	.039	.032	.011	.015

THERE ARE 22 SINGLE POINTS IN FILES:...CSLHK...CSCL6  
...CSCL7...CSCL8...CSCL9...CSCL10

APPENDIX C:  
 HARMONICS OF THE LIFT FORCE FOR SMOOTH CYLINDERS  
 BETA = 6555 , k/D = 0

<u>f</u>	<u>CL(1)</u>	<u>CL(2)</u>	<u>CL(3)</u>	<u>CL(4)</u>	<u>CL(5)</u>
5.092	.076	.034	.003	.007	.002
6.253	.041	.006	.009	.009	.007
7.733	.062	.138	.043	.033	.01
9.112	.066	.571	.019	.109	.003
9.502	.086	1.449	.113	.382	.069
10.249	.035	1.726	.046	.481	.04
10.252	.058	1.615	.02	.495	.031
10.948	.05	1.905	.061	.412	.025
11.009	.023	1.802	.036	.428	.009
12.232	.165	1.417	.156	.435	.038
13.538	.043	.814	.055	.468	.027
14.838	.028	.089	.339	.084	.13
14.838	.072	.119	.177	.264	.041
15.777	.052	.063	.254	.126	.084
15.828	.032	.124	.245	.153	.1
17.35	.023	.073	.037	.031	.006
17.357	.035	.096	.085	.31	.035
17.393	.041	.043	.066	.158	.024
19.912	.015	.037	.104	.238	.081
19.921	.047	.042	.233	.136	.136
20.031	.018	.005	.037	.064	.018
23.416	.017	.022	.116	.018	.09
23.416	.045	.035	.096	.016	.034
28.346	.016	.013	.033	.011	.086
28.355	.018	.026	.05	.012	.092
30.818	.026	.021	.021	.006	.036
34.351	.033	.032	.003	.022	.037

THERE ARE 27 SINGLE POINTS IN FILES:... DSLHK...DSCL1...  
 DSCL2...DSCL3...DSCL4...DSCL5

APPENDIX C:  
HARMONICS OF THE LIFT FORCE FOR SMOOTH CYLINDERS  
 $\beta = 6555$  ,  $k/D = 0$

<u>F</u>	<u>CL(6)</u>	<u>CL(7)</u>	<u>CL(8)</u>	<u>CL(9)</u>	<u>CL(10)</u>
5.092	.001	.001	0	.001	0
6.853	.003	.003	.001	.001	.001
7.733	.002	.004	.002	.003	.002
9.112	.007	.005	.003	.003	.002
9.502	.082	.038	.026	.02	.01
10.249	.104	.019	.032	.01	.008
10.252	.111	.019	.032	.013	.007
10.948	.084	.004	.013	.001	.003
11.009	.082	.005	.018	.002	.001
12.232	.076	.02	.017	.006	.005
12.538	.109	.004	.011	.002	.006
14.338	.043	.021	.006	.008	.003
14.338	.105	.017	.017	.006	.005
15.777	.075	.013	.03	.009	.014
15.828	.082	.032	.025	.01	.01
17.35	.011	.01	.009	.012	.009
17.367	.156	.006	.037	.009	.013
17.393	.09	.007	.023	.005	.01
19.912	.152	.039	.047	.009	.012
19.921	.085	.046	.033	.012	.007
20.031	.05	.019	.006	.01	.006
20.415	.027	.08	.03	.025	.015
20.415	.03	.017	.033	.007	.017
20.346	.031	.052	.03	.014	.011
20.355	.014	.073	.015	.017	.003
20.319	.045	.038	.043	.004	.013
24.351	.051	.013	.037	.015	.008

THERE ARE 27 SINGLE POINTS IN FILES: ...DSLHK...DSCL6  
...DSCL7...DSCL8...DSCL9...DSCL10

APPENDIX D:  
 IN-LINE FORCE COEFFICIENTS FOR ROUGH CYLINDERS  
 BETA = 2412 ,  $k/D = 1/50$

#	K	Cd	Cm	Cfmax	Carms
1	1.14	1.30	2.10	19.38	12.85
2	1.14	1.51	2.10	18.76	12.84
3	1.14	1.37	2.11	19.33	12.88
4	1.20	1.50	2.11	18.13	12.30
5	1.20	1.46	2.12	18.58	12.37
6	1.21	1.36	2.09	18.19	12.06
7	1.21	1.35	2.11	18.71	12.16
8	1.21	1.32	2.12	18.44	12.20
9	1.42	1.07	2.09	15.73	10.26
10	1.42	1.09	2.09	15.13	10.27
11	1.44	1.15	2.09	15.06	10.15
12	1.44	1.15	2.09	15.33	10.17
13	1.44	1.23	2.09	15.35	10.19
14	1.44	1.18	2.10	15.43	10.20
15	1.79	1.10	2.08	12.14	8.15
16	1.79	1.03	2.09	12.34	8.18
17	1.80	1.09	2.09	12.02	8.12
18	2.16	.99	2.08	10.11	6.75
19	2.17	1.05	2.09	9.99	6.73
20	2.18	1.00	2.08	9.89	6.69
21	2.33	1.01	2.06	9.24	6.20
22	2.33	1.04	2.07	9.26	6.21
23	2.34	.95	2.06	9.24	6.17
24	2.58	.99	2.06	8.33	5.61
25	2.58	.98	2.06	8.39	5.60
26	2.93	.99	2.04	7.29	4.89
27	2.93	1.00	2.04	7.30	4.90
28	2.93	1.02	2.04	7.33	4.90
29	3.52	1.02	2.01	5.99	4.04
30	3.52	1.03	2.02	6.01	4.05
31	3.85	1.04	2.00	5.39	3.67
32	3.87	1.09	2.00	5.42	3.66
33	4.77	1.13	1.95	4.32	2.92
34	4.78	1.09	1.94	4.27	2.90
35	4.79	1.21	1.95	4.27	2.91
36	5.54	1.20	1.89	3.65	2.49
37	5.55	1.34	1.90	3.61	2.49
38	6.77	1.39	1.78	2.94	2.00
39	6.78	1.39	1.76	2.89	2.00
40	6.78	1.40	1.77	2.88	2.01
41	6.99	1.36	1.71	2.76	1.91
42	7.00	1.28	1.73	2.78	1.92
43	7.01	1.42	1.78	2.82	1.94
44	7.68	1.43	1.66	2.57	1.76
45	7.70	1.76	1.66	2.53	1.76
46	8.09	1.68	1.47	2.71	1.68
47	8.16	1.71	1.49	2.67	1.65
48	8.25	1.70	1.45	2.48	1.63
49	8.26	1.68	1.44	2.60	1.62

..... CONTINUED

APPENDIX D:  
 IN-LINE FORCE COEFFICIENTS FOR ROUGH CYLINDERS  
 BETA = 2412 ,  $k/D = 1/50$

#	K	Cd	Cm	Cfmax	Carms
50	8.26	1.69	1.46	2.59	1.62
51	8.32	1.78	1.43	2.63	1.60
52	8.65	1.79	1.39	2.73	1.58
53	8.76	1.79	1.32	2.71	1.54
54	8.79	1.82	1.33	2.76	1.54
55	8.99	1.85	1.30	2.82	1.53
56	9.47	1.90	1.24	2.86	1.48
57	9.80	1.96	1.21	2.71	1.47
58	10.36	1.98	1.15	2.77	1.45
59	10.40	1.99	1.04	2.63	1.41
60	10.61	1.97	1.10	2.71	1.43
61	10.62	2.00	1.05	2.86	1.43
62	10.63	2.01	1.00	2.50	1.41
63	10.70	1.89	.97	2.67	1.41
64	11.53	1.86	1.12	2.63	1.37
65	12.05	1.82	1.06	2.52	1.32
66	12.91	1.88	1.16	2.17	1.30
67	13.40	1.87	.99	2.20	1.30
68	13.40	1.82	1.00	2.32	1.28
69	13.40	1.76	1.04	2.25	1.26
70	14.10	1.80	1.01	2.10	1.22
71	14.18	1.71	1.14	2.15	1.25
72	14.98	1.64	1.20	1.94	1.19
73	15.03	1.81	1.00	1.85	1.13
74	16.08	1.81	1.17	2.01	1.21
75	16.10	1.87	1.11	2.11	1.21
76	16.10	1.94	1.13	2.17	1.24
77	17.16	1.89	1.12	2.47	1.29
78	17.19	1.82	1.10	2.29	1.25
79	17.26	1.88	1.04	1.99	1.18
80	17.48	1.89	1.09	2.32	1.24
81	18.29	1.86	1.08	2.38	1.24
82	18.30	1.72	1.17	2.28	1.24
83	18.40	1.67	1.14	1.92	1.15
84	19.17	1.84	1.19	1.88	1.10
85	19.78	1.73	1.05	2.13	1.19
86	19.78	1.67	1.12	1.86	1.13
87	19.80	1.76	1.24	1.82	1.11
88	21.04	1.78	1.12	1.99	1.14
89	21.40	1.72	1.06	2.07	1.16
90	21.44	1.71	1.17	1.93	1.12
91	21.44	1.66	1.24	2.03	1.12
92	21.49	1.71	1.24	1.90	1.10
93	23.17	1.73	1.15	2.00	1.11
94	23.32	1.63	1.10	1.73	1.12
95	23.32	1.63	1.18	1.79	1.06
96	23.33	1.59	1.13	1.80	1.06
97	23.47	1.78	1.13	1.77	1.03
98	25.26	1.69	1.08	1.99	1.14
99	25.26	1.75	1.13	2.04	1.09

..... CONTINUED

APPENDIX D:  
 IN-LINE FORCE COEFFICIENTS FOR ROUGH CYLINDERS  
 BETA = 2412 , k/D = 1/50

<u>#</u>	<u>K</u>	<u>Cd</u>	<u>Cm</u>	<u>Cfmax</u>	<u>Carms</u>
100	25.26	1.68	1.14	2.13	1.13
101	27.45	1.67	1.11	1.83	1.07
102	27.49	1.69	1.13	1.94	1.07
103	27.49	1.66	1.17	1.92	1.09
104	27.51	1.61	1.22	1.83	1.07
105	29.33	1.58	1.21	1.80	1.03
106	31.39	1.59	1.10	1.75	1.00
107	31.40	1.64	1.19	1.70	1.01
108	32.96	1.61	1.10	1.70	1.03
109	33.09	1.60	1.14	1.65	1.02
110	33.10	1.57	1.21	1.64	1.02
111	35.73	1.62	1.22	1.67	.99
112	35.74	1.54	1.23	1.75	1.03
113	37.40	1.57	1.21	1.61	.97
114	37.40	1.51	1.21	1.58	.99
115	37.40	1.51	1.29	1.60	.95
116	38.92	1.52	1.20	1.57	.95
117	38.94	1.53	1.07	1.64	.95
118	38.95	1.56	1.21	1.58	.96
119	41.29	1.52	1.15	1.65	.98
120	41.35	1.50	1.16	1.63	.95
121	41.35	1.53	1.26	1.53	.95
122	43.92	1.53	1.10	1.63	.95
123	43.96	1.54	1.14	1.62	.95
124	43.99	1.51	1.19	1.58	.96
125	47.00	1.50	1.14	1.67	.95
126	47.02	1.51	1.21	1.60	.94
127	47.03	1.53	1.26	1.60	.94
128	49.50	1.53	1.16	1.76	.95
129	49.51	1.52	1.10	1.67	.95
130	49.56	1.51	1.32	1.62	.95
131	54.73	1.48	1.17	1.69	.94
132	54.87	1.52	1.10	1.56	.92
133	58.32	1.48	1.15	1.67	.95
134	58.44	1.46	1.28	1.53	.92
135	58.44	1.46	1.29	1.55	.91

THESE ARE 136 DATA PAIRS STORED AS (X,Y) IN FILES: ARDCD..ARDCM..ARDCF  
 .....and ARDCR

APPENDIX D:  
 IN-LINE FORCE COEFFICIENTS FOR ROUGH CYLINDERS  
 BETA = 3598 ,  $k/D = 1/50$

#	K	Cd	Cm	Cfmax	Carms
1	1.03	2.22	2.09	21.22	14.28
2	1.03	2.04	2.10	21.33	14.29
3	1.03	2.11	2.10	21.11	14.22
4	1.04	2.07	2.11	21.36	14.21
5	1.04	2.18	2.11	21.08	14.18
6	1.05	2.03	2.11	21.00	14.05
7	1.19	1.89	2.09	18.27	12.31
8	1.19	1.92	2.10	18.34	12.33
9	1.20	1.92	2.09	18.15	12.23
10	1.20	1.91	2.10	18.27	12.32
11	1.36	1.72	2.09	16.05	10.79
12	1.36	1.80	2.09	16.09	10.79
13	1.36	1.75	2.10	16.02	10.83
14	1.36	1.78	2.10	16.14	10.84
15	1.59	1.52	2.09	13.61	9.21
16	1.59	1.51	2.10	13.69	9.23
17	1.59	1.53	2.10	13.61	9.22
18	1.60	1.56	2.09	13.73	9.17
19	1.87	1.32	2.09	11.62	7.85
20	1.87	1.40	2.09	11.68	7.87
21	1.87	1.36	2.10	11.68	7.88
22	2.25	1.27	2.06	9.54	6.43
23	2.25	1.28	2.07	9.52	6.44
24	2.26	1.28	2.06	9.43	6.39
25	2.27	1.22	2.06	9.43	6.37
26	2.48	1.21	2.06	8.60	5.82
27	2.49	1.22	2.05	8.60	5.78
28	2.49	1.19	2.06	8.58	5.81
29	2.94	1.07	2.05	7.28	4.89
30	2.94	1.07	2.05	7.28	4.90
31	2.94	1.11	2.05	7.28	4.91
32	2.95	1.04	2.05	7.23	4.88
33	3.46	1.12	2.02	6.10	4.13
34	3.46	1.13	2.02	6.10	4.14
35	3.46	1.05	2.03	6.11	4.14
36	3.54	1.18	2.02	5.95	4.05
37	3.54	1.06	2.03	5.93	4.05
38	3.55	1.10	2.02	5.93	4.03
39	4.00	1.07	2.00	5.21	3.54
40	4.00	1.09	2.00	5.23	3.54
41	4.47	1.15	1.97	4.63	3.15
42	4.47	1.16	1.97	4.63	3.16
43	4.47	1.19	1.97	4.64	3.16
44	4.73	1.23	1.96	4.38	2.98
45	4.74	1.22	1.95	4.33	2.96
46	4.74	1.21	1.96	4.34	2.97
47	5.34	1.30	1.90	3.78	2.60
48	5.34	1.31	1.90	3.77	2.60
49	5.34	1.30	1.91	3.82	2.61

..... CONTINUED

APPENDIX D:  
 IN-LINE FORCE COEFFICIENTS FOR ROUGH CYLINDERS  
 BETA = 3598 , K D = 1.50

#	K	Cd	Cm	Cfmax	Carms
50	5.80	1.33	1.86	3.44	2.38
51	5.82	1.34	1.88	3.50	2.40
52	5.84	1.32	1.87	3.46	2.37
53	6.59	1.41	1.80	3.03	2.09
54	6.62	1.48	1.76	2.91	2.06
55	6.62	1.50	1.80	3.04	2.10
56	6.63	1.46	1.76	2.97	2.06
57	6.65	1.49	1.71	2.98	2.03
58	7.50	1.64	1.62	2.64	1.83
59	7.50	1.62	1.64	2.62	1.84
60	7.60	1.65	1.62	2.61	1.82
61	7.60	1.55	1.65	2.57	1.80
62	7.61	1.59	1.62	2.52	1.78
63	8.73	1.99	1.25	3.02	1.60
64	8.74	1.92	1.31	2.80	1.59
65	8.75	2.00	1.26	2.97	1.60
66	9.82	2.14	1.11	2.96	1.55
67	9.82	1.99	1.25	2.76	1.53
68	9.83	2.14	1.09	2.98	1.54
69	9.86	2.15	1.12	2.99	1.56
70	10.73	2.18	.91	2.56	1.48
71	10.73	2.17	.93	2.77	1.48
72	10.74	2.10	1.07	2.73	1.49
73	11.47	2.11	1.02	2.85	1.46
74	11.48	2.09	1.05	2.70	1.45
75	11.49	2.17	.88	2.71	1.46
76	11.51	2.06	1.02	2.70	1.43
77	12.19	2.13	.97	2.53	1.45
78	12.27	1.92	1.13	2.41	1.34
79	12.30	2.07	.90	2.75	1.41
80	13.27	2.08	.90	2.74	1.39
81	13.28	2.00	.95	2.60	1.36
82	13.29	2.00	.95	2.59	1.36
83	14.15	1.99	1.03	2.33	1.33
84	14.17	1.92	1.01	2.41	1.29
85	14.18	1.99	.91	2.33	1.33
86	14.18	1.90	1.08	2.25	1.28
87	15.15	1.82	1.12	2.22	1.33
88	15.15	1.82	1.19	2.17	1.26
89	15.15	1.96	1.25	2.22	1.33
90	15.18	1.93	1.00	2.38	1.29
91	15.19	1.83	.99	2.30	1.23
92	15.86	1.97	1.09	2.31	1.30
93	15.86	1.96	1.10	2.34	1.29
94	15.88	1.77	1.05	2.06	1.21
95	15.88	1.95	1.11	2.21	1.28
96	15.93	1.92	1.15	2.13	1.28
97	17.01	2.08	1.12	2.68	1.37
98	17.02	2.06	1.04	2.64	1.36
99	17.03	1.98	1.09	2.53	1.31

..... CONTINUED

APPENDIX D:  
 IN-LINE FORCE COEFFICIENTS FOR ROUGH CYLINDERS  
 BETA = 3598 ,  $k/D = 1/50$

<u>n</u>	<u>K</u>	<u>Cd</u>	<u>Cm</u>	<u>Cfmax</u>	<u>Carms</u>
100	17.07	2.00	1.01	2.35	1.29
101	17.84	2.04	1.06	2.50	1.34
102	17.85	2.02	1.18	2.77	1.35
103	17.86	2.01	1.06	2.39	1.31
104	17.87	2.04	1.00	2.57	1.33
105	17.91	1.90	1.03	2.23	1.24
106	18.83	1.91	.98	2.52	1.26
107	18.84	2.00	1.02	2.41	1.30
108	18.92	1.88	1.03	2.16	1.22
109	21.31	1.85	1.10	2.30	1.20
110	21.32	1.83	1.12	2.15	1.19
111	21.39	1.85	1.11	2.25	1.20
112	22.17	1.76	1.24	1.98	1.15
113	23.99	1.79	1.20	2.15	1.16
114	24.00	1.70	1.27	1.98	1.11
115	24.11	1.71	1.29	2.10	1.12
116	26.63	1.72	1.14	1.85	1.10
117	26.77	1.74	1.27	1.91	1.12
118	26.79	1.76	1.09	1.99	1.13
119	30.06	1.72	1.09	1.91	1.09
120	30.09	1.72	1.25	1.89	1.09
121	30.11	1.72	1.21	2.00	1.10
122	30.15	1.60	1.22	1.83	1.02
123	30.18	1.64	1.23	1.89	1.05
124	34.11	1.76	1.12	1.91	1.11
125	34.11	1.66	1.27	1.74	1.05
126	34.18	1.75	1.12	1.84	1.10
127	37.60	1.60	1.26	1.50	1.00
128	37.71	1.63	1.21	1.74	1.03
129	41.71	1.60	1.24	1.59	1.00
130	41.73	1.55	1.25	1.64	.98
131	41.73	1.56	1.28	1.72	.98
132	41.75	1.64	1.15	1.73	1.03
133	41.96	1.64	1.16	1.75	1.03
134	45.80	1.59	1.28	1.70	1.00
135	45.85	1.56	1.29	1.58	.97

THERE ARE 135 DATA PAIRS STORED AS (X,Y) IN FILES: BRDCD., BRDCM., BRDCF  
 .....and BRDCA

APPENDIX D:  
 IN-LINE FORCE COEFFICIENTS FOR ROUGH CYLINDERS  
 $\text{Re} = 4924$  ,  $k/D = 1/50$

#	K	$C_d$	$C_m$	$C_{fmax}$	$C_{arms}$
1	.99	1.92	2.03	21.43	14.38
2	.99	1.73	2.04	21.67	14.45
3	1.00	2.11	2.03	21.15	14.26
4	1.21	1.57	2.04	17.58	11.82
5	1.21	1.53	2.04	17.61	11.80
6	1.57	1.37	2.04	13.46	9.11
7	1.58	1.27	2.04	13.45	9.07
8	1.62	1.31	2.03	13.02	8.77
9	1.84	1.00	2.03	11.40	7.72
10	1.85	.99	2.03	11.38	7.66
11	1.85	.98	2.03	11.37	7.68
12	1.90	1.00	2.03	11.08	7.49
13	2.19	.94	2.03	9.59	6.49
14	2.25	1.03	2.03	9.33	6.31
15	2.74	1.04	2.00	7.58	5.14
16	2.74	.96	2.00	7.57	5.12
17	3.38	1.06	1.98	6.07	4.13
18	3.38	1.14	1.97	6.07	4.12
19	4.16	1.23	1.93	4.84	3.31
20	4.16	1.22	1.93	4.86	3.32
21	4.38	1.26	1.92	4.59	3.14
22	5.26	1.43	1.86	3.82	2.61
23	5.26	1.41	1.86	3.81	2.61
24	5.37	1.49	1.81	3.43	2.33
25	5.95	1.47	1.80	3.33	2.29
26	6.48	1.53	1.71	3.00	2.07
27	6.50	1.59	1.67	2.94	2.04
28	6.51	1.53	1.73	2.97	2.08
29	6.59	1.60	1.64	2.82	1.99
30	6.56	1.55	1.68	2.83	2.00
31	7.29	1.69	1.57	2.60	1.84
32	7.36	1.87	1.47	2.87	1.81
33	7.40	1.72	1.55	2.52	1.83
34	7.50	1.80	1.49	2.71	1.78
35	8.04	2.02	1.27	3.17	1.68
36	8.04	2.01	1.25	3.18	1.67
37	8.55	2.02	1.20	3.10	1.67
38	8.57	2.09	1.20	2.86	1.62
39	9.09	2.12	1.13	3.00	1.58
40	9.10	2.10	1.15	2.95	1.58
41	9.48	2.21	1.12	3.05	1.60
42	9.48	2.25	1.07	3.08	1.60
43	9.49	2.23	1.03	3.14	1.58
44	9.86	2.23	1.04	2.98	1.59
45	9.86	2.23	.99	2.93	1.54
46	10.67	2.19	.94	2.89	1.50
47	10.67	2.25	.89	2.84	1.52
48	11.29	2.37	.83	2.91	1.57
49	11.31	2.31	.77	2.76	1.52

..... CONTINUED

APPENDIX D:  
 IN-LINE FORCE COEFFICIENTS FOR ROUGH CYLINDERS  
 BETA = 4924 , k/D = 1/50

#	K	Cd	Cm	Cfmax	Carms
50	11.34	2.32	.83	2.83	1.53
51	11.35	2.19	1.00	2.73	1.50
52	11.63	2.24	.70	2.76	1.47
53	11.63	2.14	.96	2.93	1.47
54	11.69	2.23	.76	2.63	1.48
55	11.71	2.14	.98	2.36	1.47
56	12.05	2.33	.77	2.59	1.53
57	12.06	2.32	.77	2.77	1.53
58	12.07	2.18	1.02	2.76	1.48
59	12.13	2.28	.78	2.50	1.51
60	12.67	2.33	.65	2.55	1.52
61	12.67	2.24	.81	2.34	1.48
62	12.74	2.08	.96	2.51	1.40
63	13.01	2.14	.65	2.56	1.46
64	13.04	2.17	.81	2.50	1.44
65	13.08	2.15	.87	2.48	1.44
66	13.28	2.11	.78	2.57	1.40
67	13.29	2.03	.90	2.33	1.36
68	13.31	2.00	1.02	2.50	1.35
69	13.99	2.02	1.12	2.48	1.36
70	14.00	2.04	.76	2.48	1.36
71	14.05	1.95	1.13	2.29	1.32
72	14.24	2.01	.78	2.61	1.33
73	14.26	2.04	.85	2.52	1.35
74	14.32	1.98	1.14	2.41	1.34
75	15.40	2.05	1.04	2.48	1.35
76	15.40	1.97	1.11	2.37	1.31
77	15.51	2.00	1.08	2.35	1.32
78	16.78	2.15	1.05	2.84	1.42
79	16.81	2.11	1.03	2.76	1.39
80	16.83	2.09	.98	2.52	1.35
81	18.01	2.04	1.03	2.43	1.33
82	18.10	2.02	1.05	2.56	1.32
83	19.56	1.91	1.06	2.37	1.24
84	19.58	1.98	1.10	2.60	1.30
85	20.92	1.81	1.10	2.18	1.18
86	21.05	1.84	1.07	2.27	1.19
87	22.51	1.73	1.09	2.20	1.12
88	23.18	1.80	1.07	2.36	1.17
89	24.93	1.92	1.13	2.33	1.23
90	24.93	1.84	1.11	2.22	1.18
91	24.97	1.74	1.17	2.04	1.12
92	27.04	1.77	1.14	1.86	1.13
93	27.04	1.82	1.08	2.06	1.17
94	29.27	1.72	1.19	2.07	1.10
95	29.42	1.66	1.11	1.93	1.06
96	31.38	1.72	1.21	1.90	1.09
97	31.42	1.70	1.15	1.91	1.08
98	31.55	1.69	1.19	1.89	1.08
99	31.72	1.64	1.23	1.66	.98

..... CONTINUED

APPENDIX D:  
 IN-LINE FORCE COEFFICIENTS FOR ROUGH CYLINDERS  
 BETA = 4924 , k/D = 1.50

<u>#</u>	<u>K</u>	<u>Cd</u>	<u>Cm</u>	<u>Cfmax</u>	<u>Carms</u>
100	33.72	1.70	1.15	1.84	1.08
101	33.78	1.69	1.27	1.83	1.07
102	35.52	1.74	1.12	1.87	1.09
103	35.68	1.72	1.16	2.00	1.09
104	37.33	1.61	1.20	1.75	1.01
105	37.52	1.61	1.21	1.73	1.01
106	38.00	1.66	1.29	1.83	1.04
107	38.04	1.63	1.28	1.74	1.03

THERE ARE 107 DATA PAIRS STORED AS (X,Y) IN FILES: CRDCD..CRDCM..CRDCF  
 .....and CRDCA

APPENDIX D:  
 IN-LINE FORCE COEFFICIENTS FOR ROUGH CYLINDERS  
 BETA = 6836 ,  $k/D = 1/50$

#	K	Cd	Cm	Cfmax	Carms
1	.94	2.22	2.01	22.64	15.06
2	.95	1.96	2.01	22.45	15.09
3	1.15	1.67	2.02	18.50	12.34
4	1.15	1.79	2.02	18.38	12.35
5	1.58	1.14	2.03	13.36	8.98
6	1.58	1.16	2.02	13.39	9.00
7	1.59	1.24	2.01	13.37	8.85
8	2.08	1.03	2.02	10.05	6.80
9	2.08	1.04	2.02	10.18	6.82
10	2.08	1.02	2.01	10.07	6.79
11	2.43	1.06	2.01	8.58	5.80
12	2.45	1.04	2.00	8.53	5.74
13	2.87	1.09	1.99	7.18	4.87
14	2.88	1.07	1.98	7.15	4.84
15	3.48	1.24	1.95	5.84	3.98
16	3.48	1.22	1.95	5.86	3.98
17	4.26	1.40	1.89	4.68	3.21
18	5.27	1.51	1.84	3.79	2.60
19	5.28	1.48	1.81	3.68	2.55
20	6.00	1.57	1.79	3.26	2.28
21	6.01	1.60	1.74	3.20	2.23
22	6.58	1.62	1.68	2.37	2.04
23	6.60	1.72	1.68	3.02	2.06
24	6.60	1.70	1.63	2.33	2.01
25	7.56	1.98	1.39	2.72	1.78
26	7.56	2.04	1.37	3.04	1.80
27	8.12	2.13	1.18	3.21	1.68
28	8.13	2.11	1.17	2.31	1.66
29	8.98	2.20	1.13	3.12	1.63
30	9.02	2.24	1.01	3.07	1.60
31	9.75	2.28	.91	3.10	1.57
32	9.81	2.25	1.07	3.09	1.60
33	10.28	2.26	.91	2.96	1.56
34	10.28	2.21	1.04	2.88	1.56
35	10.28	2.23	.88	2.90	1.53
36	10.91	2.42	.62	2.71	1.57
37	10.91	2.36	.66	2.88	1.55
38	10.91	2.42	.68	2.85	1.58
39	11.51	2.37	.67	2.75	1.55
40	11.51	2.32	.72	2.89	1.54
41	11.51	2.35	.69	2.87	1.55
42	11.51	2.41	.63	2.78	1.57
43	11.84	2.33	.64	2.79	1.52
44	11.86	2.33	.71	2.80	1.55
45	12.83	2.31	.71	2.66	1.52
46	12.87	2.29	.70	2.72	1.50
47	12.89	2.21	.78	2.82	1.47
48	13.25	2.18	.85	2.65	1.44
49	13.27	2.13	.90	2.59	1.41

..... CONTINUED

APPENDIX D:  
 IN-LINE FORCE COEFFICIENTS FOR ROUGH CYLINDERS  
 BETA = 6836 , k/D = 1/50

#	K	Cd	Cm	Cfmax	Carms
50	13.71	2.15	.75	2.61	1.41
51	13.78	2.13	.98	2.49	1.41
52	14.81	2.06	1.06	2.54	1.38
53	14.82	2.03	1.02	2.44	1.34
54	14.83	2.07	1.09	2.50	1.37
55	16.16	2.07	1.10	2.62	1.37
56	16.16	2.06	1.09	2.46	1.34
57	16.17	2.11	1.12	2.65	1.39
58	17.96	2.04	1.09	2.52	1.33
59	18.05	2.03	1.14	2.63	1.35
60	18.06	1.90	1.12	2.21	1.25
61	20.18	1.88	1.17	2.19	1.22
62	20.23	1.84	1.21	2.05	1.21
63	20.28	1.78	1.23	2.16	1.17
64	22.14	1.87	1.14	2.25	1.21
65	22.27	1.82	1.19	2.12	1.18
66	22.37	1.77	1.20	2.19	1.16
67	22.38	1.81	1.13	2.20	1.17
68	24.70	1.86	1.26	2.17	1.20
69	24.87	1.74	1.15	1.97	1.13
70	26.28	1.92	1.13	2.17	1.22
71	26.51	1.82	1.15	2.09	1.17
72	26.56	1.77	1.22	1.97	1.13
73	28.26	1.86	1.17	2.15	1.19
74	28.34	1.73	1.21	1.92	1.13
75	31.24	1.73	1.27	1.88	1.10
76	31.26	1.63	1.18	1.75	1.03
77	31.46	1.71	1.22	1.86	1.09
78	32.74	1.67	1.18	1.77	1.06
79	32.92	1.82	1.19	2.08	1.15
80	33.09	1.76	1.14	2.01	1.11
81	33.15	1.73	1.18	1.88	1.10

THERE ARE 81 DATA PAIRS STORED AS (X,Y) IN FILES: DRDCD..DRDCM..DRDCF  
 .....and DRDCA

APPENDIX D:  
 IN-LINE FORCE COEFFICIENTS FOR ROUGH CYLINDERS  
 BETA = 9354 , k/D = 1/50

<u>#</u>	<u>k</u>	<u>Cd</u>	<u>Cm</u>	<u>Cfmax</u>	<u>Carms</u>
1	1.39	1.40	2.06	15.32	10.35
2	1.39	1.45	2.06	15.16	10.35
3	1.39	1.50	2.06	14.96	10.36
4	2.32	1.01	2.06	8.99	6.21
5	2.35	1.04	2.05	8.95	6.14
6	2.90	1.14	2.03	7.06	4.92
7	2.91	1.11	2.02	7.03	4.90
8	2.91	1.06	2.02	7.02	4.90
9	3.57	1.05	1.99	5.61	3.92
10	3.62	1.14	1.99	5.62	3.90
11	4.38	1.26	1.92	4.56	3.13
12	4.39	1.31	1.92	4.58	3.16
13	5.49	1.46	1.84	3.61	2.51
14	5.50	1.43	1.86	3.57	2.50
15	6.71	1.74	1.66	2.81	2.03
16	6.72	1.73	1.67	2.80	2.03
17	7.11	1.81	1.58	2.64	1.91
18	7.18	1.85	1.54	2.63	1.89
19	7.75	1.96	1.33	3.08	1.81
20	8.80	2.10	1.16	2.95	1.61
21	9.90	2.37	.97	3.19	1.63
22	9.91	2.33	.96	3.03	1.60
23	11.05	2.40	.78	2.95	1.60
24	11.05	2.33	.85	3.08	1.56
25	12.97	2.26	.64	2.82	1.50
26	13.00	2.17	.78	2.62	1.44
27	14.74	2.06	1.13	2.28	1.35
28	14.77	2.04	1.07	2.35	1.34
29	14.78	2.09	.89	2.51	1.39
30	17.36	2.18	.97	2.87	1.43
31	17.56	2.10	1.01	2.71	1.37
32	22.86	1.91	1.18	2.24	1.23
33	22.86	1.71	1.17	1.99	1.11
34	29.25	1.71	1.12	1.87	1.09
35	29.31	1.70	1.20	1.90	1.09
36	32.93	1.70	1.09	1.82	1.07
37	33.26	1.71	1.16	1.79	1.08
38	35.16	1.75	1.03	1.85	1.10
39	35.31	1.67	1.14	1.75	1.05
40	35.47	1.67	1.03	1.75	1.05
41	36.96	1.67	1.11	1.82	1.04
42	38.63	1.67	1.18	1.79	1.03
43	38.77	1.70	1.14	1.80	1.06

THESE ARE 43 DATA PAIRS STORED AS (X,Y) IN FILES: CRDHCD..CRDHCM..CRDHCF  
 .....and CRDHCA

APPENDIX D:  
 IN-LINE FORCE COEFFICIENTS FOR ROUGH CYLINDERS  
 SETA = 14200 , k D = 1.50

#	K	Cd	Cm	Cfmax	Carms
1	1.15	1.75	2.02	18.11	12.22
2	1.15	1.72	2.03	18.32	12.35
3	1.16	1.67	2.03	18.32	12.27
4	1.80	1.13	2.03	11.70	7.89
5	1.91	1.15	2.03	11.79	7.94
6	1.81	1.11	2.04	11.82	8.00
7	2.36	1.13	2.02	8.36	6.00
8	2.37	1.11	2.02	8.37	5.98
9	2.77	1.13	2.01	7.64	5.10
10	2.77	1.12	2.01	7.56	5.15
11	3.56	1.31	1.96	5.76	3.93
12	3.57	1.30	1.96	5.76	3.91
13	4.88	1.56	1.86	4.13	2.81
14	4.89	1.55	1.86	4.13	2.82
15	5.84	1.65	1.77	3.84	2.33
16	5.87	1.73	1.80	3.53	2.38
17	6.99	1.86	1.56	2.75	1.94
18	6.99	1.93	1.50	2.69	1.92
19	7.73	2.17	1.28	3.07	1.78
20	7.73	2.18	1.23	2.90	1.75
21	7.73	2.21	1.25	3.31	1.78
22	8.45	2.25	1.20	3.17	1.71
23	8.49	2.31	1.18	3.21	1.73
24	9.77	2.41	.90	3.05	1.63
25	9.77	2.35	.98	3.04	1.64
26	11.06	2.51	.63	2.93	1.65
27	11.11	2.37	.69	2.94	1.57
28	11.11	2.54	.66	2.84	1.64
29	12.48	2.30	.64	2.82	1.51
30	12.49	2.35	.66	2.87	1.54
31	12.49	2.30	.71	2.82	1.52
32	13.74	2.02	1.08	2.49	1.37
33	13.74	2.18	.94	2.59	1.44
34	13.77	2.16	1.06	2.75	1.43
35	13.78	2.28	.86	2.73	1.50
36	16.72	2.17	1.09	2.90	1.44
37	16.83	2.09	1.12	2.84	1.39
38	20.04	1.84	1.21	2.10	1.21
39	20.06	1.87	1.19	2.29	1.22
40	20.07	2.00	1.16	2.52	1.31
41	26.48	1.78	1.17	1.98	1.14
42	26.48	1.80	1.19	1.94	1.16
43	26.53	1.72	1.23	1.95	1.10
44	26.54	1.76	1.17	1.90	1.13
45	29.86	1.63	1.24	1.77	1.05
46	29.86	1.67	1.21	1.80	1.07
47	29.86	1.66	1.25	1.84	1.07
48	31.90	1.75	1.18	1.98	1.10
49	31.90	1.76	1.22	1.91	1.11
50	31.90	1.77	1.21	1.98	1.12
51	31.90	1.69	1.18	1.80	1.06
52	32.17	1.66	1.27	1.72	1.05
53	32.17	1.71	1.25	1.76	1.08
54	34.30	1.70	1.22	1.75	1.07
55	34.30	1.70	1.20	1.75	1.07
56	34.30	1.69	1.19	1.74	1.06

THERE ARE 56 DATA PAIRS STORED AS (X,Y) IN FILES: IRDHCD..DRDHIM..DRDHCF  
 .....300 DRDHCF

APPENDIX D:  
 IN-LINE FORCE COEFFICIENTS FOR MARINE ROUGHENED CYLINDER  
 BETA = 8100 ,  $k/D = 1/50$  , (Position A)

#	K	Cd	Cm	Cfmax
1	4.47	1.56	1.41	3.21
2	5.84	1.59	1.25	2.33
3	6.41	1.71	1.14	1.88
4	7.78	1.83	.87	1.91
5	9.31	1.87	.72	1.92
6	11.64	1.67	.97	1.67
7	13.03	1.64	1.00	1.70
8	15.51	1.60	.81	1.60
9	18.95	1.56	.88	1.59
10	21.23	1.64	1.15	1.68
11	22.44	1.62	1.07	1.70
12	23.88	1.54	1.17	1.54
13	29.33	1.60	.91	1.59
14	31.82	1.57	1.00	1.58
15	34.59	1.60	.96	1.64
16	42.26	1.51	.98	1.54
17	46.77	1.42	1.06	1.49
18	52.57	1.42	1.10	1.48
19	59.84	1.42	.98	1.47

THERE ARE 19 DATA PAIRS STORED AS (X,Y) IN FILES: A18KCD..A18KCM..A18KCF

APPENDIX D:  
 IN-LINE FORCE COEFFICIENTS FOR MARINE ROUGHENED CYLINDER  
 BETA = 10964 ,  $k/D = 1/50$  , (Position A)

#	K	Cd	Cm	Cfmax
1	4.13	2.10	1.37	3.64
2	6.22	1.80	1.08	2.24
3	7.26	1.97	.76	1.90
4	8.66	1.93	.58	1.77
5	10.53	1.85	.63	1.88
6	12.20	1.61	1.00	1.69
7	15.04	1.73	.72	1.66
8	15.74	1.69	.98	1.97
9	16.82	1.78	.80	1.71
10	18.65	1.61	.81	1.52
11	19.67	1.61	.73	1.74
12	20.92	1.56	.92	1.63
13	22.34	1.57	.84	1.53
14	27.53	1.66	.97	1.53
15	29.95	1.51	1.01	1.65
16	32.52	1.61	1.07	1.61
17	44.90	1.58	.98	1.51
18	50.85	1.51	1.18	1.54
19	58.66	1.58	1.14	1.58

THERE ARE 19 DATA PAIRS STORED AS (X,Y) IN FILES: A38KCD..A38KCM..A38KCF

APPENDIX D:  
 IN-LINE FORCE COEFFICIENTS FOR MARINE ROUGHENED CYLINDER  
 BETA = 13724 ,  $k/D = 1/50$  , (Position A)

#	K	Cd	Cm	Cfmax
1	4.39	2.07	1.34	3.03
2	5.46	1.80	1.25	2.57
3	6.30	1.72	1.14	2.02
4	9.23	1.87	.82	1.60
5	9.26	1.73	.83	1.57
6	11.93	1.71	.94	1.23
7	12.23	1.70	.85	1.85
8	13.77	1.64	.94	1.73
9	15.13	1.61	.92	1.96
10	17.60	1.68	.85	1.89
11	20.98	1.67	.88	1.82
12	24.00	1.57	.83	1.55
13	27.67	1.63	1.02	1.62
14	30.03	1.67	.91	1.65
15	40.33	1.60	1.09	1.61
16	44.97	1.55	1.15	1.50
17	50.99	1.51	1.00	1.47
18	58.66	1.45	1.20	1.29

THERE ARE 18 DATA PAIRS STORED AS (X,Y) IN FILES: A58KCD..A58KCM..A58KCF

APPENDIX D:  
 IN-LINE FORCE COEFFICIENTS FOR MARINE ROUGHENED CYLINDER  
 BETA = 13890 ,  $k/D = 1/50$  , (Position A)

#	K	Cd	Cm	Cfmax
1	4.51	2.00	1.33	2.90
2	5.13	1.84	1.29	2.44
3	5.58	1.77	1.26	2.50
4	6.34	1.76	1.20	2.22
5	7.37	1.69	1.03	1.47
6	8.49	1.76	.74	1.77
7	10.99	1.95	.67	2.08
8	14.71	1.67	.89	1.82
9	18.01	1.66	.74	1.84
10	20.23	1.65	.81	1.71
11	23.00	1.60	.87	1.58
12	28.57	1.60	1.15	1.55
13	31.13	1.53	1.13	1.50
14	33.90	1.63	.99	1.49
15	41.72	1.50	.95	1.33
16	46.55	1.48	1.19	1.33
17	53.05	1.45	1.20	1.45
18	60.67	1.52	1.21	1.48

THERE ARE 18 DATA PAIRS STORED AS (X,Y) IN FILES: A78KCD..A78KCM..A78KCF

APPENDIX D:  
 IN-LINE FORCE COEFFICIENTS FOR MARINE ROUGHENED CYLINDER  
 BETA = 13122 ,  $k/D = 1/50$  , (Position B)

#	K	Cd	Cm	Cfmax
1	5.19	1.87	1.45	2.97
2	7.19	2.21	1.04	2.42
3	9.05	2.24	.76	2.56
4	11.47	2.06	1.01	2.07
5	13.74	2.05	1.03	1.14
6	15.07	2.08	1.08	2.33
7	16.71	1.99	1.04	2.12
8	18.93	1.88	1.05	1.90
9	21.47	1.76	1.09	1.73
10	26.57	1.64	1.15	1.47
11	28.85	1.65	1.14	1.65
12	31.27	1.62	1.02	1.52
13	38.26	1.68	1.09	1.77
14	42.54	1.59	.98	1.53
15	48.01	1.59	1.17	1.56
16	54.79	1.56	1.26	1.43

THERE ARE 16 DATA PAIRS STORED AS (X,Y) IN FILES: A98KCD..A98KCM..A98KCF

APPENDIX D:  
 IN-LINE FORCE COEFFICIENTS FOR MARINE ROUGHENED CYLINDER  
 BETA = 13517 ,  $k/D = 1/50$  , (Position B)

#	K	Cd	Cm	Cfmax
1	5.14	1.93	1.48	2.99
2	6.00	2.13	1.24	2.41
3	7.16	2.33	.87	2.46
4	8.40	2.35	.77	2.45
5	9.69	2.42	.66	2.49
6	11.05	2.42	.49	2.45
7	12.73	2.16	.61	2.20
8	14.02	1.88	.97	1.95
9	15.38	1.85	1.02	1.87
10	18.21	1.87	1.19	1.92
11	20.42	1.72	1.18	1.54
12	23.28	1.67	1.25	1.47
13	25.11	1.75	1.01	1.63
14	26.29	1.88	1.11	1.95
15	29.41	1.77	1.12	1.84
16	32.31	1.82	1.05	1.75
17	39.99	1.63	1.00	1.62
18	44.49	1.56	.97	1.64
19	50.85	1.57	1.13	1.51

THERE ARE 19 DATA PAIRS STORED AS (X,Y) IN FILES: A11KCD..A11KCM..A11KCF

APPENDIX E:  
 RMS VALUE OF THE LIFT FORCE FOR ROUGH CYLINDERS  
 $\beta = 2412$  ,  $kD = 1/50$

#	K	Crms	#	K	Crms
1	5.064	.408	2	5.066	.525
3	6.45	.691	4	6.461	.547
5	6.472	1.077	6	8.262	1.554
7	8.34	1.517	8	9.046	1.626
9	9.079	1.643	10	9.557	1.602
11	9.718	1.513	12	10.383	1.608
13	10.43	1.599	14	10.913	1.374
15	11.895	1.484	16	13.319	1.187
17	13.341	1.113	18	14.123	1.082
19	14.167	1.022	20	14.793	.955
21	14.798	1.036	22	14.826	.995
23	15.591	.921	24	15.714	.956
25	16.529	1.099	26	16.584	.868
27	17.534	1.151	28	17.673	1.06
29	18.315	1.066	30	18.337	1.081
31	19.66	.895	32	19.66	.92
33	21.039	.732	34	21.05	.827
35	24.771	.694	36	29.864	.633
37	29.864	.65	38	35.739	.642
39	35.739	.703	40	36.814	.625
41	40.066	.588	42	40.094	.621
43	43.973	.518	44	44.015	.609
45	44.252	.499	46	47.197	.598
47	47.267	.542	48	47.434	.49
49	49.765	.509	50	52.988	.495
51	53.114	.485	52	53.142	.481
53	57.649	.503	54	57.733	.484
55	58.612	.45	56	58.612	.467
57	58.752	.453	58	0	0

THERE ARE 57 DATA PAIRS STORED AS (X,Y) IN FILE NO: ARLCL

APPENDIX E:  
 RMS VALUE OF THE LIFT FORCE FOR ROUGH CYLINDERS  
 BETA = 3598 ,  $k/D = 1/50$

#	K	Clrms	#	K	Clrms
1	4.613	.287	2	4.624	.201
3	4.963	.419	4	4.969	.392
5	4.972	.46	6	6.386	1.184
7	6.459	1.118	8	6.474	1.265
9	6.982	1.211	10	7.054	1.405
11	7.366	1.431	12	7.368	1.465
13	7.377	1.524	14	7.889	1.631
15	7.891	1.576	16	9.028	1.621
17	9.051	1.637	18	10.027	1.544
19	10.04	1.612	20	10.82	1.538
21	10.87	1.514	22	11.885	1.407
23	11.944	1.236	24	13.054	1.142
25	13.067	.997	26	14.022	.994
27	14.04	.963	28	14.955	.961
29	14.964	1.021	30	15.027	1.223
31	15.091	1.025	32	15.096	1.144
33	15.969	1.087	34	17.097	1.115
35	17.111	1.124	36	17.124	1.215
37	17.856	1.169	38	17.916	1.156
39	18.138	1.048	40	18.188	1.005
41	19.107	.878	42	19.107	.953
43	19.799	.887	44	19.83	.953
45	22.059	.936	46	22.105	.816
47	24.333	.929	48	24.345	.915
49	25.015	.913	50	25.015	1.032
51	25.129	1.021	52	25.209	.935
53	27.54	.906	54	25.551	.775
55	30.576	.777	56	30.644	.768
57	33.668	.747	58	33.725	.68
59	37.842	.632	60	37.853	.607
61	41.526	.702	62	41.673	.623
63	42.754	.699	64	42.867	.579
65	46.313	.546	66	46.37	.576
67	46.472	.526	68	0	0

THERE ARE 67 DATA PAIRS STORED AS (X,Y) IN FILE NO: BRCLL

APPENDIX E:  
RMS VALUE OF THE LIFT FORCE FOR ROUGH CYLINDERS  
 $\beta = 4924$  ,  $k/D = 1/50$

#	K	Clrms	#	K	Clrms
1	4.385	.205	2	4.419	.245
3	4.806	.379	4	4.816	.369
5	5.652	.542	6	5.674	.514
7	5.676	.843	8	5.783	.623
9	5.795	.862	10	6.302	1.16
11	6.375	1.265	12	6.392	.896
13	6.4	1.207	14	6.645	1.2
15	6.67	1.29	16	6.745	1.158
17	6.859	1.154	18	6.901	1.238
19	7.079	1.397	20	7.449	1.573
21	7.483	1.471	22	7.902	1.708
23	7.917	1.672	24	8.552	1.723
25	8.567	1.671	26	8.571	1.657
27	9.108	1.645	28	9.143	1.666
29	9.305	1.643	30	10.126	1.697
31	10.134	1.615	32	11.238	1.535
33	11.238	1.534	34	12.19	1.396
35	12.142	1.365	36	13.074	1.212
37	13.164	1.24	38	13.172	1.129
39	13.861	1.107	40	13.932	1.091
41	14.744	1.21	42	14.82	.9
43	14.851	.792	44	14.774	.983
45	14.786	1.134	46	15.972	1.16
47	15.987	1.074	48	16.294	1.145
49	16.317	1.16	50	16.356	1.015
51	17.396	1.178	52	17.419	1.2
53	17.427	1.126	54	17.993	1.123
55	18.031	1.137	56	18.559	.968
57	18.973	.955	58	19.135	.935
59	19.192	.905	60	19.835	.789
61	20.286	.932	62	20.286	.764
63	20.286	.932	64	20.315	.817
65	21.371	.812	66	21.447	.855
67	24.019	.947	68	24.086	.971
69	24.115	.853	70	24.144	.926
71	25.084	.951	72	25.833	.867
73	25.852	.887	74	25.938	.815
75	27.445	.796	76	27.503	.752
77	27.637	.776	78	29.412	.699
79	29.959	.701	80	29.969	.705
81	29.998	.7	82	32.301	.823
83	32.339	.798	84	32.502	.61
85	32.579	.677	86	32.723	.8
87	32.886	.822	88	34.92	.653
89	35.064	.696	90	35.083	.635
91	35.179	.708	92	36.648	.616
93	36.648	.616	94	36.676	.654
95	36.907	.656	96	37.252	.553
97	37.262	.565	98	0	0

THERE ARE 97 DATA PAIRS STORED AS (X,Y) IN FILE NO: CRLCL

APPENDIX E:  
 RMS VALUE OF THE LIFT FORCE FOR ROUGH CYLINDERS  
 BETA = 6836 ,  $k/D = 1/50$

#	K	Clrms	#	K	Clrms
1	3.776	.17	2	3.776	.129
3	4.042	.16	4	4.044	.151
5	4.707	.357	6	4.709	.347
7	5.416	.563	8	5.456	.961
9	5.481	.617	10	5.724	.925
11	5.82	1.053	12	6.15	1.199
13	6.156	.955	14	6.837	1.32
15	6.853	1.333	16	6.882	1.613
17	7.532	1.646	18	7.54	1.565
19	7.928	1.73	20	7.964	1.642
21	9.012	1.627	22	9.022	1.635
23	10.08	1.563	24	10.117	1.514
25	11.178	1.507	26	11.188	1.532
27	12.512	1.341	28	12.535	1.298
29	14.715	1.231	30	14.735	1.189
31	17.624	1.114	32	17.699	.973
33	19.528	.946	34	19.62	.842
35	21.358	.676	36	21.375	.9
37	23.121	.995	38	23.213	1.015
39	23.279	.843	40	24.294	.905
41	24.302	.967	42	24.502	.805
43	26.964	.862	44	26.981	.68
45	28.952	.601	46	28.894	.625
47	28.977	.696	48	31.588	.766
49	31.588	.804	50	31.663	.71
51	31.696	.695	52	0	0

THERE ARE 51 DATA PAIRS STORED AS (X,Y) IN FILE NO: DRLCL

APPENDIX F:  
HARMONICS OF THE LIFT FORCE FOR ROUGH CYLINDERS  
ETA = 2412 , K/D = 1.50

<u>F</u>	<u>CL(1)</u>	<u>CL(2)</u>	<u>CL(3)</u>	<u>CL(4)</u>	<u>CL(5)</u>
5.064	.094	.153	.022	.026	.004
5.066	.074	.192	.001	.032	.005
6.45	.056	.442	.015	.067	.004
6.461	.087	.043	.000	.014	.007
6.472	.076	1.29	.05	.196	.024
8.262	.864	1.825	.499	.426	.158
8.34	.867	1.749	.532	.378	.182
9.046	.7	1.992	.39	.525	.151
9.079	.753	1.995	.403	.533	.169
9.557	.677	1.941	.376	.55	.155
9.713	.657	1.833	.323	.524	.124
10.333	.502	1.903	.279	.575	.102
10.43	.586	1.844	.293	.572	.098
10.913	.419	1.554	.31	.61	.035
11.395	.352	1.764	.161	.585	.031
13.319	.273	1.233	.288	.669	.093
13.341	.251	1.111	.246	.624	.115
14.123	.395	.731	.833	.644	.2
14.167	.2	.833	.444	.697	.14
14.793	.125	.721	.447	.606	.104
14.798	.37	.581	.917	.643	.233
14.826	.096	.664	.126	.688	.108
15.631	.239	.554	.666	.733	.236
15.714	.3	.535	.838	.651	.297
16.529	.439	.171	1.208	.231	.496
16.534	.207	.468	.504	.56	.21
17.634	.306	.086	1.246	.108	.72
17.673	.284	.061	1.163	.09	.583
18.315	.243	.127	1.017	.171	.693
18.337	.285	.065	1.099	.178	.745
18.66	.131	.006	.793	.005	.644
18.66	.107	.06	.706	.299	.603
21.039	.023	.061	.022	.049	.071
21.05	.16	.032	.519	.139	.606
24.771	.102	.047	.174	.072	.397
29.364	.028	.106	.051	.26	.127
29.364	.022	.058	.037	.132	.036
35.739	.044	.039	.097	.068	.162
35.739	.017	.013	.019	.095	.036
36.314	.081	.031	.105	.018	.182
40.066	.017	.017	.013	.059	.014
40.094	.057	.025	.064	.066	.092
43.973	.024	.04	.015	.095	.025
44.015	.03	.075	.055	.068	.075
44.252	.047	.061	.027	.079	.021

..... CONTINUED

APPENDIX F:  
HARMONICS OF THE LIFT FORCE FOR ROUGH CYLINDERS  
BETA = 2412 , k/D = 1/50

<u>f</u>	<u>CL(1)</u>	<u>CL(2)</u>	<u>CL(3)</u>	<u>CL(4)</u>	<u>CL(5)</u>
47.197	.008	.052	.009	.057	.016
47.267	.026	.044	.03	.026	.05
47.434	.028	.025	.023	.019	.041
49.765	.025	.017	.062	.031	.081
52.988	.005	.02	.027	.03	.014
53.114	.015	.032	.033	.018	.025
53.142	.045	.018	.021	.005	.07
57.649	.024	.035	.011	.053	.01
57.733	.016	.005	.009	.03	.014
58.612	.002	.003	.001	.002	0
58.612	.025	.022	.011	.01	.019
58.752	.029	.015	.006	.034	.006

THERE ARE 57 SINGLE POINTS IN FILES:...ARLHK...ARCL1  
...ARCL2...ARCL3...ARCL4...ARCL5

APPENDIX F:  
HARMONICS OF THE LIFT FORCE FOR ROUGH CYLINDERS  
ETA = 2412 , k/D = 1/50

<u>f</u>	<u>CL(6)</u>	<u>CL(7)</u>	<u>CL(8)</u>	<u>CL(9)</u>	<u>CL(10)</u>
5.054	.001	.001	.002	.002	.004
5.066	.005	.001	.002	.001	.001
6.45	.002	.002	.004	.005	.003
6.451	.005	.004	.004	.002	.004
6.472	.024	.013	.003	.002	.002
8.262	.119	.059	.044	.027	.015
8.34	.11	.067	.05	.028	.019
9.046	.131	.082	.049	.034	.02
9.079	.14	.086	.055	.034	.02
9.557	.133	.078	.05	.029	.018
9.713	.118	.061	.042	.022	.012
10.333	.132	.067	.046	.025	.015
10.43	.133	.058	.041	.025	.014
10.913	.18	.029	.057	.015	.013
11.895	.151	.04	.035	.017	.007
13.319	.195	.024	.054	.019	.007
13.341	.164	.041	.036	.029	.003
14.123	.2	.029	.072	.021	.024
14.157	.196	.048	.06	.027	.003
14.793	.161	.022	.044	.018	.005
14.798	.14	.016	.071	.044	.03
14.826	.166	.035	.029	.016	.001
15.691	.252	.062	.082	.012	.026
15.714	.22	.077	.062	.012	.031
16.529	.061	.114	.041	.054	.032
16.534	.183	.038	.043	.006	.025
17.634	.04	.28	.013	.094	.011
17.673	.043	.167	.016	.058	.015
18.315	.119	.291	.057	.108	.018
18.337	.11	.291	.053	.085	.035
19.66	.031	.263	.031	.092	.023
19.66	.169	.255	.073	.094	.031
21.039	.034	.038	.026	.012	.012
21.05	.091	.29	.027	.114	.01
24.771	.066	.201	.035	.07	.021
29.854	.393	.083	.208	.047	.067
29.854	.138	.025	.06	.008	.015
35.739	.158	.272	.221	.183	.149
35.739	.023	.015	.089	.026	.055
36.314	.151	.36	.123	.233	.056
40.066	.143	.031	.167	.033	.092
40.094	.158	.126	.233	.106	.134
43.973	.141	.073	.352	.078	.259
44.015	.075	.169	.312	.226	.285
44.252	.168	.06	.268	.093	.187

.... CONTINUED

APPENDIX F:  
HARMONICS OF THE LIFT FORCE FOR ROUGH CYLINDERS  
BETA = 2412 , k/D = 1/50

<u>f</u>	<u>CL(6)</u>	<u>CL(7)</u>	<u>CL(8)</u>	<u>CL(9)</u>	<u>CL(10)</u>
47.197	.05	.007	.204	.049	.211
47.257	.028	.01	.2	.058	.175
47.434	.038	.072	.066	.14	.054
49.755	.024	.102	.007	.283	.043
52.938	.035	.011	.037	.025	.077
53.114	.05	.054	.045	.082	.059
53.142	.033	.034	.03	.147	.057
57.649	.092	.029	.067	.059	.237
57.733	.054	.074	.029	.036	.115
58.612	.001	.005	.002	.004	.013
58.612	.072	.039	.03	.098	.131
58.752	.038	.006	.036	.055	.089

THERE ARE 57 SINGLE POINTS IN FILES:...ARLHK...ARCL6  
...ARCL7...ARCL8...ARCL9...ARCL10

APPENDIX F:  
HARMONICS OF THE LIFT FORCE FOR ROUGH CYLINDERS  
ETA = 3598 , K/D = 1/50

<u>F</u>	<u>CL(1)</u>	<u>CL(2)</u>	<u>CL(3)</u>	<u>CL(4)</u>	<u>CL(5)</u>
4.813	.108	.128	.034	.028	.003
4.824	.111	.075	.028	.014	.004
4.953	.09	.542	.027	.093	.006
4.959	.097	.523	.008	.073	.002
4.972	.106	.613	.024	.101	.005
6.086	.112	1.655	.048	.265	.03
6.459	.057	1.536	.052	.242	.025
6.474	.146	1.724	.019	.288	.026
6.982	.075	1.626	.057	.264	.021
7.054	.084	1.922	.032	.39	.011
7.066	.103	1.959	.026	.396	.026
7.363	.102	1.986	.043	.393	.048
7.377	.176	2.068	.166	.426	.113
7.889	.08	1.997	.447	.429	.161
7.891	.783	1.942	.42	.387	.181
9.023	.622	2.075	.341	.515	.131
9.051	.56	2.139	.359	.533	.134
10.027	.646	1.929	.361	.575	.126
10.04	.487	2.079	.299	.574	.132
10.82	.442	1.929	.3	.586	.113
10.87	.512	1.87	.267	.585	.104
11.835	.171	1.814	.102	.562	.019
11.944	.544	1.262	.534	.624	.085
13.054	.359	1.2	.414	.621	.062
13.067	.407	.788	.74	.522	.186
14.022	.262	.881	.443	.64	.106
14.04	.238	.839	.305	.613	.064
14.955	.131	.738	.169	.729	.062
14.964	.207	.615	.139	.507	.114
15.027	.637	.303	1.442	.249	.475
15.091	.112	.519	.252	.475	.146
15.096	.474	.519	1.214	.549	.347
15.969	.474	.239	1.307	.286	.428
17.097	.304	.114	1.209	.149	.62
17.111	.4	.13	1.259	.201	.592
17.124	.339	.062	1.371	.021	.772
17.856	.355	.089	1.28	.063	.793
17.916	.336	.114	1.179	.24	.772
18.138	.21	.073	1.067	.152	.661
18.138	.205	.041	1.059	.036	.631
19.107	.175	.023	.825	.05	.562
19.107	.219	.089	.942	.152	.674
19.799	.119	.028	.776	.067	.546
19.83	.132	.087	.916	.186	.614
22.059	.092	.12	.174	.691	.103

... CONTINUED

APPENDIX F:

HARMONICS OF THE LIFT FORCE FOR ROUGH CYLINDERS

BETA = 3598 , k/D = 1/50

<u>f</u>	<u>CL(1)</u>	<u>CL(2)</u>	<u>CL(3)</u>	<u>CL(4)</u>	<u>CL(5)</u>
22.105	.118	.041	.171	.1	.054
24.333	.088	.079	.23	.712	.307
24.345	.082	.068	.213	.055	.331
25.015	.018	.033	.028	.813	.069
25.015	.038	.013	.081	.863	.053
25.129	.017	.051	.021	1.002	.026
25.209	.05	.015	.046	.83	.047
27.54	.025	.122	.042	.679	.05
27.551	.042	.03	.048	.096	.055
30.576	.094	.046	.093	.068	.65
30.644	.062	.035	.083	.201	.64
33.668	.067	.012	.085	.077	.563
33.725	.03	.048	.018	.04	.037
37.842	.035	.02	.055	.049	.096
37.853	.026	.026	.124	.045	.145
41.526	.059	.049	.018	.194	.081
41.673	.011	.056	.045	.117	.053
42.754	.028	.02	.026	.117	.012
42.857	.022	.054	.02	.089	.016
46.313	.024	.035	.018	.062	.058
46.37	.02	.077	.019	.078	.04
46.472	.003	.008	.01	.026	.106

THERE ARE 67 SINGLE POINTS IN FILES:...BRLHK...BRCL1  
 ...BRCL2...BRCL3...BRCL4...BRCL5

APPENDIX F:  
HARMONICS OF THE LIFT FORCE FOR ROUGH CYLINDERS  
 $\beta = 35.38$  ,  $k D = 1.50$

<u>F</u>	<u>CL(6)</u>	<u>CL(7)</u>	<u>CL(8)</u>	<u>CL(9)</u>	<u>CL(10)</u>
4.813	.006	.004	.004	.001	.002
4.824	.005	.002	0	.001	.001
4.853	.013	.002	.002	.003	.001
4.869	.01	.002	.002	.002	.002
4.872	.014	.004	.005	.001	.002
5.136	.035	.012	.008	.004	.002
5.459	.027	.011	.006	.002	.003
5.474	.047	.009	.013	.005	.004
5.882	.038	.006	.016	.002	.008
7.054	.084	.006	.029	.003	.009
7.166	.085	.02	.029	.014	.008
7.263	.078	.024	.028	.014	.01
7.277	.096	.06	.032	.023	.011
7.889	.101	.066	.035	.023	.01
7.891	.078	.068	.038	.021	.016
9.023	.11	.058	.039	.022	.016
9.051	.116	.059	.038	.021	.011
10.027	.127	.068	.05	.026	.016
10.04	.124	.068	.045	.027	.015
10.82	.133	.063	.045	.026	.014
10.87	.132	.063	.044	.022	.015
11.335	.138	.02	.04	.012	.007
11.944	.186	.026	.052	.021	.009
13.054	.179	.02	.052	.017	.01
13.067	.158	.036	.052	.005	.012
14.022	.153	.006	.047	.019	.011
14.04	.162	.011	.041	.006	.007
14.955	.173	.035	.053	.03	.024
14.964	.103	.073	.021	.041	.01
15.027	.105	.081	.077	.06	.043
15.031	.139	.057	.05	.043	.014
15.036	.138	.068	.079	.025	.051
15.969	.079	.078	.051	.05	.038
17.097	.099	.167	.051	.058	.021
17.111	.069	.152	.018	.061	.02
17.124	.039	.27	.033	.114	.03
17.856	.02	.301	.015	.097	.018
17.916	.155	.319	.08	.118	.041
18.138	.096	.273	.055	.097	.024
18.138	.019	.255	.017	.093	.012
19.137	.026	.206	.011	.063	.013
19.137	.083	.267	.036	.08	.019
19.739	.05	.191	.025	.051	.013
19.93	.092	.269	.045	.098	.029
22.059	.403	.047	.142	.043	.05

.... CONTINUED

APPENDIX F:  
HARMONICS OF THE LIFT FORCE FOR ROUGH CYLINDERS  
BETA = 3598 , k/D = 1/50

<u>f</u>	<u>CL(6)</u>	<u>CL(7)</u>	<u>CL(8)</u>	<u>CL(9)</u>	<u>CL(10)</u>
22.105	.019	.017	.009	.019	.013
24.333	.476	.167	.186	.048	.056
24.345	.594	.129	.258	.029	.117
25.015	.681	.036	.298	.027	.111
25.015	.733	.025	.316	.018	.104
25.129	.787	.017	.324	.009	.102
25.209	.727	.026	.324	.037	.101
27.54	.744	.05	.382	.035	.147
27.551	.05	.081	.016	.039	.034
30.576	.045	.574	.041	.241	.014
30.644	.276	.552	.127	.234	.029
33.668	.109	.581	.04	.288	.026
33.725	.032	.1	.018	.065	.022
37.842	.067	.238	.069	.203	.034
37.853	.068	.345	.054	.263	.036
41.526	.335	.08	.521	.047	.281
41.673	.207	.17	.385	.2	.266
42.754	.2	.093	.398	.126	.314
42.867	.135	.042	.283	.045	.197
46.313	.016	.113	.184	.187	.172
46.37	.048	.045	.35	.067	.302
46.472	.062	.135	.163	.25	.127

THERE ARE 67 SINGLE POINTS IN FILES:...BRLHK...BRCL6  
...BRCL7...BRCL8...BRCL9...BRCL10

APPENDIX F:  
HARMONICS OF THE LIFT FORCE FOR ROUGH CYLINDERS  
BETA = 4924 , k/D = 1/50

<u>F</u>	<u>CL(1)</u>	<u>CL(2)</u>	<u>CL(3)</u>	<u>CL(4)</u>	<u>CL(5)</u>
4.385	.037	.253	.003	.045	.004
4.413	.049	.099	.006	.011	.006
5.652	.02	.655	.019	.089	.005
5.674	.071	.582	.018	.09	.012
5.675	.042	1.091	.028	.15	.009
6.373	.1	1.716	.039	.297	.012
7.079	.07	1.892	.112	.332	.067
7.917	.705	2.142	.439	.381	.167
8.571	.772	2.081	.471	.473	.149
8.552	.799	2.174	.467	.547	.148
9.143	.749	2.049	.455	.536	.146
10.126	.517	2.206	.344	.599	.12
12.119	.281	1.7	.432	.584	.108
13.172	.415	1.1	.479	.62	.096
14.736	.284	.694	.951	.593	.317
17.419	.308	.112	1.266	.175	.789
18.973	.209	.118	.945	.061	.609
21.371	.1	.025	.635	.108	.525
24.146	.063	.092	.047	.807	.083
25.804	.026	.041	.029	.914	.114
27.445	.062	.072	.004	.553	.133
29.959	.041	.058	.033	.124	.031
32.301	.056	.018	.08	.049	.679
37.252	.015	.057	.008	.162	.067

THERE ARE 24 SINGLE POINTS IN FILES:...CRLHK...CRCL1  
...CRCL2...CRCL3...CRCL4...CRCL5

APPENDIX F:  
HARMONICS OF THE LIFT FORCE FOR ROUGH CYLINDERS  
BETA = 4924 , k/D = 1/50

<u>f</u>	<u>CL(6)</u>	<u>CL(7)</u>	<u>CL(8)</u>	<u>CL(9)</u>	<u>CL(10)</u>
4.185	.008	.003	.002	0	.001
4.419	.002	.001	.002	0	.001
5.652	.017	.003	.001	0	.001
5.874	.013	.003	.004	.002	.002
5.875	.02	.004	.003	.001	0
6.873	.051	.011	.014	.005	.005
7.079	.046	.029	.01	.014	.007
7.917	.083	.059	.034	.017	.013
8.571	.105	.064	.035	.023	.012
8.552	.141	.079	.053	.034	.02
9.143	.13	.075	.05	.028	.017
10.126	.137	.062	.05	.024	.016
12.119	.158	.038	.046	.016	.012
13.172	.189	.015	.056	.005	.016
14.736	.176	.072	.077	.019	.04
17.419	.11	.333	.057	.123	.029
18.973	.012	.246	.023	.079	.016
21.371	.047	.207	.043	.066	.019
24.146	.572	.01	.22	.026	.068
25.804	.763	.087	.327	.06	.117
27.445	.601	.093	.283	.019	.101
29.959	.051	.067	.05	.036	.026
32.301	.087	.695	.078	.334	.045
37.252	.344	.077	.402	.056	.176

THERE ARE 24 SINGLE POINTS IN FILES:...CRLHK...CRCL6  
...CRCL7...CRCL8...CRCL9...CRCL10

APPENDIX F:  
HARMONICS OF THE LIFT FORCE FOR ROUGH CYLINDERS  
BETA = 6836 , k/D = 1/50

<u>F</u>	<u>CL(1)</u>	<u>CL(2)</u>	<u>CL(3)</u>	<u>CL(4)</u>	<u>CL(5)</u>
4.042	.1	.071	.029	.014	.002
4.044	.119	.038	.018	.009	.003
4.709	.114	.174	.039	.034	.01
5.415	.086	.779	.02	.093	.006
5.82	.082	1.343	.011	.178	.006
6.15	.078	1.661	.07	.255	.034
6.882	.661	2.093	.406	.357	.153
7.532	.21	2.159	.03	.442	.03
7.54	.159	2.085	.084	.474	.076
7.923	.627	2.24	.388	.438	.157
9.012	.708	2.06	.414	.522	.163
9.022	.711	2.081	.38	.531	.138
10.03	.574	2.03	.273	.548	.133
10.117	.611	1.918	.275	.561	.123
11.138	.132	2.035	.064	.629	.055
12.512	.067	1.742	.063	.615	.022
14.735	.489	.563	1.174	.611	.355
17.699	.202	.376	.864	.619	.47
19.528	.155	.038	.871	.021	.627
21.375	.069	.14	.121	.751	.193
23.279	.015	.071	.048	.81	.064
24.294	.063	.049	.14	.134	.317
24.302	.049	.066	.052	.932	.196
24.502	.09	.023	.19	.13	.41
26.931	.135	.03	.05	.094	.391
28.977	.105	.046	.068	.047	.335
31.633	.119	.042	.145	.009	.426

THERE ARE 27 SINGLE POINTS IN FILES:...DRLHK...DRCL1  
...DRCL2...DRCL3...DRCL4...DRCL5

APPENDIX F:  
HARMONICS OF THE LIFT FORCE FOR ROUGH CYLINDERS  
BETA = 6836 , k/D = 1/50

<u>F</u>	<u>CL(6)</u>	<u>CL(7)</u>	<u>CL(8)</u>	<u>CL(9)</u>	<u>CL(10)</u>
4.042	.003	.002	.001	0	.001
4.044	.001	.002	.001	.001	.001
4.709	.003	.005	.003	.001	.001
5.416	.017	.004	.003	.004	.002
5.82	.015	.004	.003	.002	.003
6.15	.036	.013	.009	.006	.002
6.882	.061	.054	.024	.014	.009
7.532	.07	.016	.01	.008	.006
7.54	.124	.051	.049	.024	.019
7.923	.085	.065	.032	.022	.013
9.012	.131	.076	.048	.031	.018
9.022	.122	.07	.046	.024	.016
10.03	.119	.054	.036	.018	.012
10.117	.121	.072	.043	.027	.015
11.138	.157	.033	.041	.022	.012
12.512	.155	.016	.049	.008	.014
14.735	.153	.061	.083	.017	.053
17.639	.3	.124	.108	.05	.021
19.528	.002	.245	.004	.083	.007
21.375	.465	.099	.146	.032	.035
23.279	.503	.032	.186	.046	.057
24.234	.119	.139	.056	.033	.03
24.302	.718	.139	.286	.046	.078
24.502	.087	.199	.039	.049	.032
26.931	.085	.308	.048	.144	.029
28.977	.166	.295	.132	.118	.069
31.633	.045	.466	.062	.211	.047

THERE ARE 27 SINGLE POINTS IN FILES:...DRLHK...DRCL6  
...DRCL7...DRCL8...DRCL9...DRCL10

INITIAL DISTRIBUTION LIST

1. National Science Foundation 20  
Washington, D. C. 20550  
Attn: Dr. Steven Traugott
2. Library, Code 0212 2  
Naval Postgraduate School  
Monterey, CA 93943-5000
3. Research Administration, Code 012 1  
Naval Postgraduate School  
Monterey, CA 93943-5000
4. Defense Technical Information Center 2  
Cameron Station  
Alexandria, VA 22314
5. Prof. T. Sarpkaya, Code 69SL 20  
Mechanical Engineering  
Naval Postgraduate School  
Monterey, CA 93943-5000
6. Chairman, Dept. of Mechanical 2  
Engineering, Code 69  
Naval Postgraduate School  
Monterey, CA 93943-5000
7. Dr. Peter W. Bearman 1  
Department of Aeronautics  
Imperial College  
Prince Consort Road  
London SW7 2BY, ENGLAND
8. Dr. John R. Bishop 1  
National Maritime Institute  
St. John's Street  
Hytke  
Southampton SO4 6YS, ENGLAND
9. Dr. Leon E. Borgman 1  
University of Wyoming  
Laramie, WY 82070
10. British Hydromechanics Research Association 1  
Cranfield, Bedford,  
ENGLAND

11. California Institute of Technology 1  
Library  
Pasadena, CA 91109
12. Dr. Subrata K. Chakrabarti 1  
Chicago Bridge & Iron Co.,  
Route 59  
Plainfield, IL 60544
13. Commander 1  
DTNSR&DC  
Bldg. 19, Rm: 129B  
Bethesda, MD 20084
14. Commander 1  
Naval Sea Systems Command  
Washington, D. C. 20362
15. Commanding Officer (L31) 1  
Naval Civil Engineering Laboratory  
Port Hueneme, CA 93043
16. Prof. Charles Dalton 1  
College of Engineering  
Office of the Dean  
University of Houston  
Houston, TX 77004
17. Department of Ocean Engineering 1  
MIT  
Cambridge, MA 02139
18. Department of Ocean Engineering 1  
University of Hawaii  
2565 The Mall  
Honolulu, Hawaii 96822
19. Director 1  
Naval Research Laboratory  
Washington, D. C. 20375-5000
20. Florida Atlantic University 1  
Ocean Engineering Dept.  
Boca Raton, Florida 33432
21. Dr. Yoshimi Goda 1  
Marine Hydrodynamics Division  
Port and Harbour Institute  
Ministry of Transport  
Nagase, Yokosuka, JAPAN

- 22. Harvard University 1  
Gordon McKay Library  
Pierce Hall  
Cambridge, MA 02138
- 23. Prof. Yuichi Iwagaki 1  
Civil Engineering Dept.  
Kyoto University  
9 Shimogamo Zenbucho, Sakyo-ku  
Kyoto, JAPAN
- 24. Library of Congress 1  
Science & Technology Division  
Washington, D. C. 20540
- 25. Massachusetts Institute of Technology 1  
Library  
Cambridge, MA 02139
- 26. Dr. David J. Maull 1  
Engineering Department  
University of Cambridge  
Trumpington Street  
Cambridge, ENGLAND
- 27. Dr. John A. Mercier 1  
CONOCO  
P. O. Box 2197  
Houston, TX 77001
- 28. Prof. John H. Nath 1  
Dept. of Civil Engineering  
Oregon State University  
Corvallis, Oregon 97331-2302
- 29. National Science Foundation 2  
Engineering Division Library  
1800 G. Street, N. W.  
Washington, D. C. 20550
- 30. Ocean Engineering Dept. 1  
Woods Hole Oceanographic Inc.  
Woods Hole, MA 02543
- 31. Office of Naval Research 1  
800 N. Quincy Street  
Arlington, VA 22217
- 32. Science Applications, Inc. 1  
134 Holiday Court, Suite 318  
Annapolis, MD 21401

33. Southwest Research Institute 1  
P. O. Drawer 28510  
San Antonio, TX 78284  
Attn: Dr. H. Abramson
34. St. Anthony Falls Hydraulics Laboratory 1  
University of Minnesota  
Mississippi River at 3rd Ave., S.E.  
Minneapolis, Minnesota 55414
35. The River & Harbour Laboratory 1  
The Norwegian Institute of Technology  
7034 Trondheim - NTH, NORWAY
36. Univ. of California 1  
Technical Library  
Berkeley, CA 94720
37. Prof. R. G. Dean 1  
Univ of Florida  
Gainesville, Florida 32611
38. Dr. Michael Graham 1  
Dept. of Aeronautics  
Imperial College  
Prince Consort Road  
London SW7 2BY, ENGLAND
39. Dr. Robert E. Haring 1  
Exxon Production Research Co.,  
Box 2189  
Houston, TX 77001
40. Dr. John C. Heideman 1  
Exxon Production Research Co.,  
P. O. Box 2189  
Houston, TX 77001
41. Dr. Wayne W. Jamieson 1  
National Research Council  
Montreal Road, M-32  
Ottawa, Ontario K1A 0R6, CANADA
42. Dr. Peter L. Monkmeier 1  
Univ. of Wisconsin, Madison  
1261C Engineering Bldg.  
Madison, WI 53706
43. Dr. William J. Nordell 1  
Naval Civil Engineering Laboratory  
Port Hueneme, CA 93043

44. Dr. J. Randolph Paulling 1  
 Dept. of Naval Architecture  
 Univ. of California  
 Berkeley, CA 94720
45. Dr. George Rodenbusch 1  
 Shell Development Co.,  
 P. O. Box 481  
 Houston, TX 77001
46. Dr. E. A. Silva 1  
 Office of Naval Research  
 800 N. Quincy St.  
 Arlington, VA 22217
47. Dr. Richard Silvester 1  
 Dept. of Civil Engineering  
 Univ. of Western Australia  
 Nedlands 6009  
 WESTERN AUSTRALIA
48. Dr. Alf Torum 1  
 Norwegian Hydrodynamics Laboratory  
 P. O. Box 4118  
 Valentinlyst, N-7001  
 Trondheim, NORWAY
49. Dr. J. Kim Vandiver 1  
 MIT  
 Dept. of Ocean Engineering  
 77 Mass Ave., Rm: 5-222  
 Cambridge, MA 02139
50. Marine Civil Engineering 1  
 Institute of Hydrodynamics & Hydraulics  
 Technical Univ. of Denmark  
 DK-2800 Lyngby  
 DENMARK
51. Franzius-Institut fur Wasserbau 1  
 Technische Universitat Hannover  
 Mienburgerstrasse 4, 3-Hannover  
 WEST GERMANY
52. Delft Hydraulics Laboratory 1  
 Voorsterweg 28, 8316PT Marknesse  
 THE NETHERLANDS
53. Prof. C. C. Mei 1  
 MIT, Bldg. 48  
 Cambridge, MA 02139

54. Prof. F. Raichlen 1  
W. M. Keck Laboratory  
California Institute of Technology  
Pasadena, CA 91109
55. Chief of Naval Research 1  
800 N. Quincy St.,  
Arlington, VA 22217
56. Hokkaido University 1  
Dept. of Engineering Science  
Kita 13, Nishi 8  
Sapporo, JAPAN
57. Osaka City University 1  
Faculty of Engineering  
459 Sugito-cho, Sumiyoshi-ku  
Osaka, JAPAN
58. Technische Universitat Hannover 1  
Library  
15 Callinstrasse  
3 Hannover, WEST GERMANY
59. University of Melbourne 1  
Library  
Parkville, Victoria 3052  
AUSTRALIA
60. Det-Norske Veritas 1  
Boks 300  
1322 H0vik  
NORWAY
61. Norwegian Hydrodynamics Laboratories 1  
Marine Technology Centre  
P. O. Box 4125 Valentinlyst  
7001 Trondheim  
NORWAY
62. Institut Francais du Petrol 1  
Library  
1 - 4 Av. Bois Preau  
92506 Rueil Malmaison  
FRANCE
63. London Marine Technology Centre 1  
University College  
Torrington Place  
London, ENGLAND

64. Dr. John Chaplin 1  
 Univ. of Liverpool  
 Dept. of Civil Engineering  
 P. O. Box 147  
 Liverpool, ENGLAND
65. Hydraulic Research Station 1  
 Howbery Park  
 Wallingford, Oxfordshire OX10 8BA  
 ENGLAND
66. Nagasaki Technical Institute 1  
 Mitsubishi Heavy Industries, Ltd.,  
 1-1 Askunoura-Macht  
 Nagasaki 850-91, JAPAN
67. National Maritime Institute 1  
 Library  
 Feltham, Middlesex TW14 0LQ  
 ENGLAND
68. National Research Council of Canada 1  
 Ottawa, Ontario K1A 0R6  
 CANADA
69. Dr. Gilles Susbielles 1  
 Institut Francais du Petrol  
 1-4 Avenue de Bois Preau  
 92506 Rueil-Malmaison  
 FRANCE
70. Swedish Maritime Research Centre SSPA 1  
 Library  
 Statens Skeppsprovninganstalt  
 P. O. Box 24001  
 S-400 22 Gothenburg  
 SWEDEN
71. Technische Universitat Berlin 1  
 Inst. fur Wasserbau und Wasserwirtschaft  
 Strasse des 17. Juni 142-144  
 1000 Berlin 12  
 WEST GERMANY
72. University of Melbourne 1  
 Library  
 Grattan St.,  
 Parkville, Victoria 3052  
 AUSTRALIA

73. U. S. Naval Academy 1  
Hydromechanics Lab.,  
Rickover Hall  
Annapolis, MD 21402
74. Webb Institute of Naval Architecture 1  
Attn: Library  
Crescent Beach Road  
Glen Cove, L.I., N. Y. 11542
75. Woods Hole Oceanographic Institute 1  
Ocean Engineering Department  
Woods Hole, MA 02543
76. Dr. M. M. Zdravkovich 1  
Mechanical Engineering  
University of Salford  
Salford M5 4WT, ENGLAND
77. Prof. Werner Zielke 1  
University of Hannover  
Callinstrasse 32  
D3000 Hannover 1  
WEST GERMANY

END

DTIC

8-86