

AD-A169 625

IMPROVED SIGNAL DELAY BOUNDS FOR RC TREE NETWORKS(U)
MASSACHUSETTS INST OF TECH CAMBRIDGE RESEARCH LAB OF
ELECTRONICS D STANDLEY ET AL. MAY 86 VLSI-MEMO-86-317
N00014-80-C-0622

1/1

UNCLASSIFIED

F/B 9/1

NL

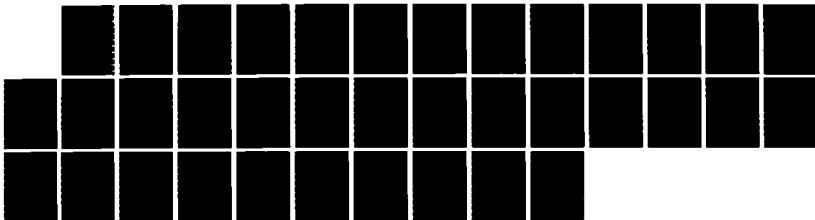

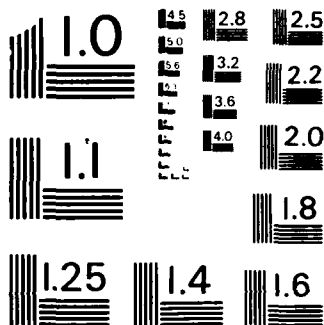

MICROCOPY RESOLUTION TEST CHART
NATIONAL BUREAU OF STANDARDS-1963-A

12



AD-A169 625

MASSACHUSETTS INSTITUTE OF TECHNOLOGY

VLSI PUBLICATIONS

VLSI Memo No. 86-317
May, 1986

IMPROVED SIGNAL DELAY BOUNDS FOR RC TREE NETWORKS

David Standley and John L. Wyatt, Jr.

Abstract

Paul Penfield and collaborators have derived upper and lower bounds on the step response of RC tree networks used to model device interconnections in MOS integrated circuits [Rubinstein, Penfield, and Horowitz]. These bounds are computationally efficient and hence suited for use in CAD programs for timing analysis. The main result of this paper, Theorem 1, allows us to replace the time constant, T_p , in the original bounds by a new one $T_{pi} \leq T_p$, thereby tightening the original bounds given by Rubinstein, Penfield, and Horowitz.

DTIC FILE COPY

DTIC
JUL 10 1986

Approved for Release by NSA on 05-08-2013 pursuant to E.O. 13526

86 7 2 0 6

Microsystems
Research Center
Room 39-321

Massachusetts
Institute
of Technology

Cambridge
Massachusetts
02139

Telephone
(617) 253-8138

Acknowledgements

This research was supported in part by the National Science Foundation under Grant No. ECS83-10941 and by the Defense Advanced Research Projects Agency under Contract No. N00014-80-C-0622.

Author Information

Standley and Wyatt: Research Laboratory of Electronics and the Department of Electrical Engineering and Computer Science, MIT, Cambridge MA 02139,
Standley: Room 36-865, (617) 253-0464, Wyatt: Room 36-864, (617) 253-6718.

Copyright (c) 1986, MIT. Memos in this series are for use inside MIT and are not considered to be published merely by virtue of appearing in this series. This copy is for private circulation only and may not be further copied or distributed, except for government purposes, if the paper acknowledges U. S. Government sponsorship. References to this work should be either to the published version, if any, or in the form "private communication." For information about the ideas expressed herein, contact the author directly. For information about this series, contact Microsystems Research Center, Room 39-321, MIT, Cambridge, MA 02139; (617) 253-8138.



Improved Signal Delay Bounds for RC Tree Networks

David Standley and John L. Wyatt, Jr.

Accession For	
NTIS GRA&I	<input checked="" type="checkbox"/>
DTIC TAB	<input type="checkbox"/>
Unannounced	<input type="checkbox"/>
Justification	
By _____	
Distribution/ _____	
Availability Codes	
Avail and/or	
Dist	Special
A-1	

ABSTRACT

Paul Penfield and collaborators have derived upper and lower bounds on the step response of RC tree networks used to model device interconnections in MOS integrated circuits [Rubinstein, Penfield, and Horowitz]. These bounds are computationally efficient and hence suited for use in CAD programs for timing analysis. The main result of this paper, Theorem 1, allows us to replace the time constant T_p in the original bounds by a new one $T_{pi} \leq T_p$, thereby tightening the original bounds given in [Rubinstein, Penfield, and Horowitz].

This research was supported in part by the National Science Foundation under Grant No. ECS83-10941 and by the Defense Advanced Research Projects Agency under Contract No. N00014-80-C-0622.

I. Introduction

Paul Penfield and collaborators have derived upper and lower bounds on the step response of RC tree networks used to model device interconnections in MOS integrated circuits [Rubinstein, Penfield, and Horowitz]. These bounds are computationally efficient and hence suited for use in CAD programs for timing analysis. The main result of this paper, Theorem 1, allows us to replace the time constant T_p in the original bounds by a new one $T_{p_i} \leq T_p$, thereby tightening the original bounds in [Rubinstein, Penfield, and Horowitz].

Definition 1

A node k in a general tree network is a leaf node if it has exactly one branch attached to it. In an RC tree network a leaf node is a node that is attached to exactly one resistor and is not attached to a source.

Definition 2

An RC tree is nonseparable if $R_{jk} > 0, \forall j,k$. Otherwise it is separable.

If a separable RC tree has all of its resistors positive, then there are at least two resistors attached to the voltage source, so that this tree consists of two or more component trees such that each has exactly one resistor attached to the source. But each of these component trees is nonseparable. Thus, a separable RC tree having only positive resistors can be "separated" into several nonseparable, non-interacting, RC trees driven by a voltage source; this is important to recognize when applying

the improvement given in this paper.

Main Result - Theorem 1

Given a nonseparable RC tree network for which the Penfield bounds are applicable, and given an output node i , the time constant $T_P \triangleq \sum_k R_{kk} C_k$ in [Rubinstein, Penfield, and Horowitz] can be replaced in all bound formulas by the new time constant $T_{Pi} \leq T_P$ given by

$$T_{Pi} = \max \left\{ T_{Di}, \max_{\substack{\text{all leaf} \\ \text{nodes } l}} \left\{ \sum_k \frac{R_{ki} R_{kl}}{R_{il}} C_k \right\} \right\}. \quad (1.1)$$

The resulting step response bounds will be valid, and if $T_{Pi} < T_P$, they will be strictly tighter than those in [Rubinstein, Penfield, and Horowitz]. If i is a leaf node, then i can be (but does not have to be) omitted from the set of nodes for which the expression is computed, i.e.,

$$T_{Pi} = \max \left\{ T_{Di}, \max_{\substack{\text{all leaf} \\ \text{nodes} \\ l \neq i}} \left\{ \sum_k \frac{R_{ki} R_{kl}}{R_{il}} C_k \right\} \right\}. \quad (1.2)$$

A brief review of the derivation of the Penfield bounds and the improvement given in [Nabors] for an RC line are given in section II, along with a numerical example to illustrate the basic idea. A proof of Theorem 1 is given in section III; it is an extension of the improvement in [Nabors] for RC trees. Section IV contains the proof of a special lemma used in section III.

II. Room for Improvement in Existing Results

2.1) Structure of the Bound Derivation

The partial derivation of the Penfield bounds given here provides the background needed to understand the improvement. For convenience we consider the input to be a falling unit step as in [Horowitz]. The voltage at node i can be written in terms of the capacitor voltage derivatives as:

$$v_i(t) = -\sum_k R_{ki} C_k \dot{v}_k(t), \quad \forall t \geq 0. \quad (2.1)$$

The state variable $g_i(t)$ is defined as:

$$g_i(t) \triangleq \int_t^{\infty} v_i(t') dt', \quad \forall t \geq 0. \quad (2.2)$$

Using (2.1) in (2.2) gives

$$g_i(t) = -\sum_k R_{ki} C_k \int_t^{\infty} \dot{v}_k(t') dt', \quad \forall t \geq 0, \quad (2.3)$$

or

$$g_i(t) = \sum_k R_{ki} C_k v_k(t), \quad \forall t \geq 0, \quad (2.4)$$

which can be expressed as

$$g_i(t) = \left[\sum_k R_{ki} C_k \left(\frac{v_k(t)}{v_i(t)} \right) \right] v_i(t), \quad \forall t \geq 0, \quad (2.5)$$

because $v_i(t) \neq 0, \forall t$. Any time-independent upper bound \bar{b}_{ki} on the ratio $v_k(t)/v_i(t)$ can be used in (2.5) to give

$$g_i(t) \leq \left[\sum_k R_{ki} C_k \bar{b}_{ki} \right] v_i(t), \quad \forall t \geq 0, \quad (2.6)$$

where

$$v_k(t)/v_i(t) \leq \bar{b}_{ki}, \quad \forall t \geq 0. \quad (2.7)$$

A time constant T_{Pi} can be defined and used in (2.6):

$$g_i \leq T_{Pi} v_i(t), \quad \forall t \geq 0, \quad (2.8)$$

where

$$T_{Pi} \triangleq \sum_k R_{ki} C_k \bar{b}_{ki}. \quad (2.9)$$

The value for \bar{b}_{ki} used in the original work was [Rubinstein, Penfield, and Horowitz, p. 204]

$$\bar{b}_{ki} = R_{kk}/R_{ki}, \quad (2.10)$$

which, when substituted into (2.9), yields

$$T_{Pi} = \sum_k R_{kk} C_k. \quad (2.11)$$

Note that this expression for T_{Pi} is independent of the output node i ; it is the original time constant T_p in the bound formula:

$$T_p = \sum_k R_{kk} C_k. \quad (2.12)$$

The contribution of this paper is to derive a smaller value for \bar{b}_{ki} , yielding the lower value for T_{Pi} in (1.1) and (1.2).

2.2) An Illustration of the Bound Improvement Technique

This section illustrates the idea for improving the bounds described by [Nabors]. Figure 2.1 shows a nonuniform RC line with a corresponding plot of a typical node voltage distribution at a fixed instant of time. A plot of the upper bound on $v_k(t)$ (given $v_i(t)$) in (2.10) is also shown. Note that $v_k(t)$ is "concave downward" as a function of the distance along the abscissa (which is scaled in proportion to R_{kk} for each k). However, the upper bound on $v_k(t)$ is "concave upward"; it is a very loose bound. A better bound can be found by drawing a straight line through the point $(i, v_i(t))$ so that it lies on or above $v_k(t)$

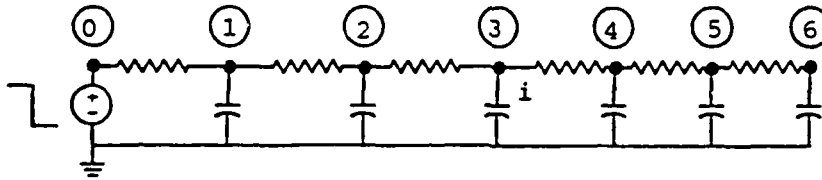

Fig. 2.1a) Nonuniform RC line.

for each k . The resulting \bar{b}_{ki} , which is valid for the instant of time being considered, can be substituted into (2.6) to give a tighter state constraint valid at that instant. Generally this improved \bar{b}_{ki} will change with time; there is no simple form for it. However, the result of substituting this time-varying \bar{b}_{ki} into the expression $\sum_k R_{ki} C_k \bar{b}_{ki}$ of (2.6) can in turn be bounded by a time-independent constant; this constant can replace the original coefficient in (2.6) (which is T_p). It is a smaller yet valid value for T_{pi} in (2.9). A demonstration of this

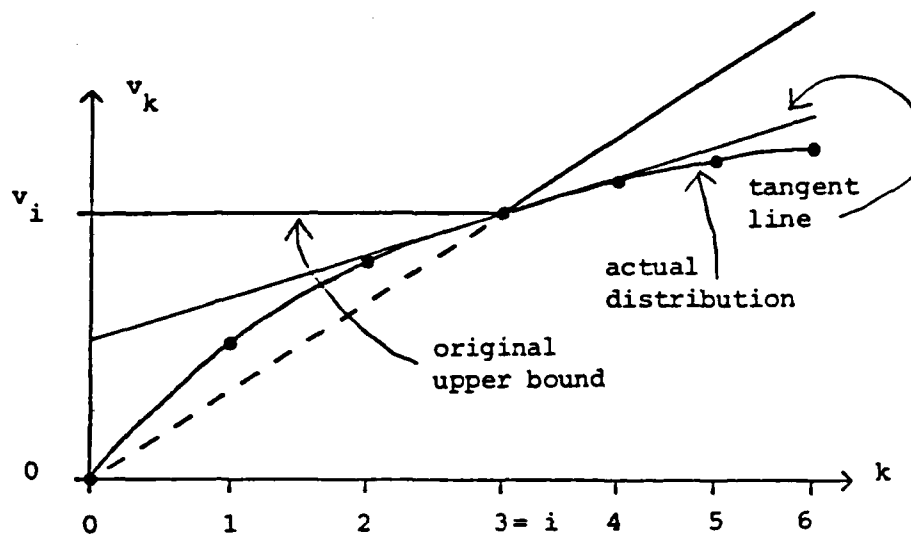

Fig. 2.1b) Plot of a typical node voltage distribution at some fixed $t > 0$. Since distance along the abscissa is proportional to R_{kk} in this plot, the slope of the voltage distribution represents dv/dR_{kk} or resistor current. The plot is concave downward because resistor current decreases with distance along the line. The observation that any tangent line is a global upper bound for a function that is concave downward enables us to find a better value for T_{pi} than that which results from use of the original upper bound, drawn above.

follows in two parts: 1) existence of a straight-line bound, and 2) derivation of the resultant improved T_{pi} value.

Existence of a Straight-Line Bound

From Fig. 2.1 (and the general property of voltage convexity along the line) it can be seen that there is a straight-line bound that has a slope between 0 and v_i/R_{ii} (where the t argument is dropped from $v_k(t)$). This is equivalent to the existence of a $\lambda(t) \in [0,1]$ such that

$$v_k \leq \hat{v}_k \triangleq v_i + \lambda(R_{ki} - R_{ii})(v_i/R_{ii}) \quad (2.13)$$

for all k , because the right side of (2.13) is the expression for this bound in terms of a normalized slope parameter λ . Thus at each instant there is some $\lambda \in [0,1]$ such that

$$\frac{v_k}{v_i} \leq \frac{\hat{v}_k}{\hat{v}_i} = 1 + \frac{\lambda(R_{kk} - R_{ii})}{R_{ii}} \triangleq \hat{b}_{ki}(\lambda). \quad (2.14)$$

Improved T_{pi} Value

Substituting (2.14) into (2.5) yields

$$g_i(t) \leq \left[\sum_k R_{ki} C_k \hat{b}_{ki}(\lambda(t)) \right] v_i(t) = \hat{T}_{Pi}(\lambda(t)) v_i(t), \quad \forall t \geq 0, \quad (2.15)$$

where

$$\begin{aligned} \hat{T}_{Pi}(\lambda) &\triangleq \sum_k R_{ki} C_k \hat{b}_{ki}(\lambda) \\ &= \sum_k R_{ki} C_k \left(1 + \left(\frac{\lambda(R_{kk} - R_{ii})}{R_{ii}} \right) \right). \end{aligned} \quad (2.16)$$

Note that $\hat{T}_{Pi}(\lambda)$ is of the form $a+b\lambda$, and hence for each t

$$\begin{aligned} \hat{T}_{Pi}(\lambda(t)) &\leq \max \{ \hat{T}_{Pi}(0), \hat{T}_{Pi}(1) \} \\ &\triangleq T_{Pi}. \end{aligned} \quad (2.17)$$

This bound is time-independent. A substitution using (2.15), (2.16), and

(2.17) gives

$$g_i(t) \leq T_{Pi} v_i(t) , \quad (2.18)$$

where

$$T_{Pi} = \max \left\{ T_{Di} , \sum_k \left(\frac{R_{kk} R_{ki}}{R_{ii}} \right) C_k \right\}. \quad (2.19)$$

Since $R_{ki}/R_{ii} \leq 1$,

$$\sum_k R_{kk} C_k (R_{ki}/R_{ii}) \leq T_P . \quad (2.20)$$

Also $T_{Di} \leq T_P$; this and (2.20) used in (2.19) give

$$T_{Pi} \leq T_P . \quad (2.21)$$

Circuit Interpretation of the Straight-Line Bound

The new bound has a circuit interpretation in the sense that it can be produced by a line of resistors with the same values as those in the original RC line; this is called the bounding line. Figure 2.2 shows this line with a voltage source at the input end and a current source at the other end. The source values are parameterized by λ and are constrained so that the node i voltage in the bounding line, \hat{v}_i , equals v_i (in the actual line). The distribution $\{\hat{v}_k\}$ in the bounding line is given by the right side of (2.13). The previous argument has shown that there is some value of λ between 0 and 1 that will give a voltage distribution $\{\hat{v}_k(\lambda)\}$ that upper bounds $\{v_k\}$ (of the real line) for a given instant of time. One of the two endpoint values of λ , $\lambda=0$ or $\lambda=1$, gives a $\{\hat{v}_k\}$ such that a valid value of T_{Pi} ($= \hat{T}_{Pi}(\lambda)$) results from its substitution

into (2.16).

A subtle point to note here is that this choice of λ corresponds to a voltage distribution $\{\hat{v}_k\}$ that is not a valid upper bound for the true distribution $\{v_k\}$. But the use of this distribution maximizes

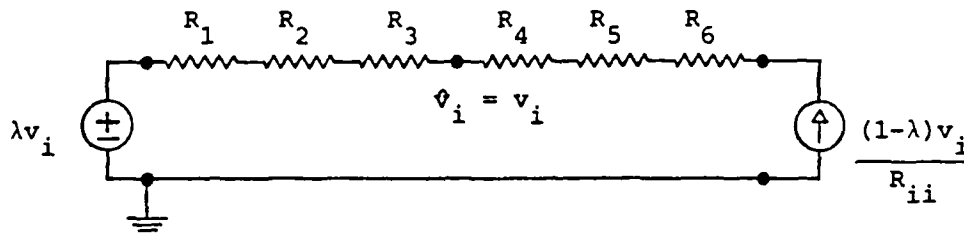

Fig. 2.2 The "bounding line", a circuit for producing a node voltage bounding distribution $\{v_k\}$. There exists a $\lambda(t) \in [0,1]$ such that $\hat{v}_k \geq v_k$, $\forall k$, for any instant of time.

$$\hat{T}_{Pi}(\lambda) \text{ and thus } \hat{T}_{Pi}(\lambda(t)) \leq \max_{\lambda=0,1} \hat{T}_{Pi}(\lambda) \triangleq T_{Pi}.$$

2.3) Numerical Example

Example 2.1 is a sample calculation of all the time constants for a uniform version of the line in Fig. 2.1 with i in the middle of the line. The new constant T_{Pi} can be compared with the original constant T_p ; it gives a tighter bound when used in the formulas. Values of R_k , C_k , R_{kk} , and R_{ki} are given below for $i=3$.

k	R_k	C_k	R_{kk}	$R_{ki} = R_{k3}$
1	1	1/6	1	1
2	1	1/6	2	2
3	1	1/6	3	3
4	1	1/6	4	3
5	1	1/6	5	3
6	1	1/6	6	3

$$e=3$$

$$T_{D3} = \sum_k R_{k3} C_k = 2.5$$

$$T_{R3} = \sum_k R_{k3}^2 C_k / R_{33} = 2.28$$

$$T_P = \sum_k R_{kk} C_k = 3.5$$

$$T_{P3} = \max \left\{ \left(\sum_k (R_{kk} R_{k3} C_k / R_{33}) \right), T_{D3} \right\}$$

$$= \max \{ 59/18, 2.5 \} = 3.28$$

$$T_{R3} = 2.28$$

$$T_{D3} = 2.5$$

$$T_P = 3.5$$

$$T_{P3} = 3.28$$

Example 2.1. Sample calculation of T_{Ri} , T_{Di} , T_P , and T_{Pi} for a uniform six resistor line with i at the center.

III. Proof of Theorem 1 (Main Result)

3.1) Notation

This section gives notation and some definitions used in the proof of Theorem 1. The following definition is based on an RC tree satisfying the conditions of Theorem 1 with a falling unit step input. An example appears in Fig. 3.1.

Definition 3.1

N is defined as the network that results by removing all non-resistive branches in the tree.

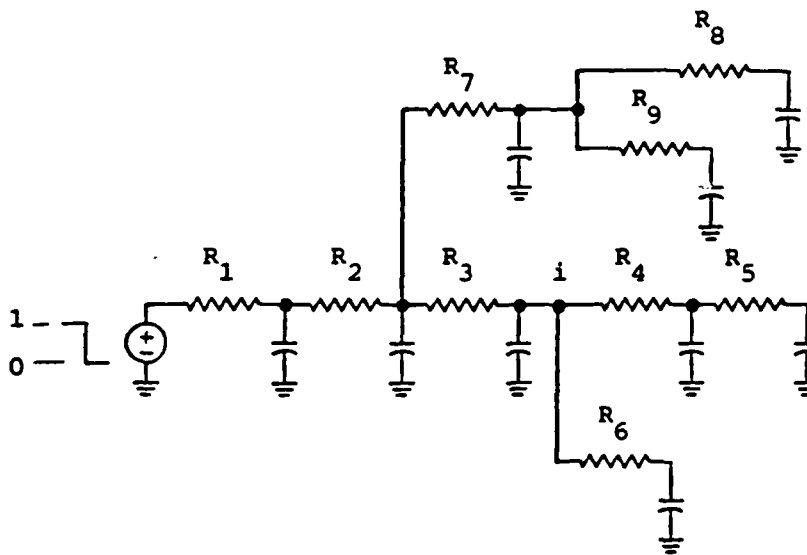

Fig. 3.1 RC tree satisfying the conditions of Theorem 1, with falling step input. $R_k > 0, \forall k$. The tree is nonseparable.

Fig. 3.2 shows N for the tree of Fig. 3.1. N has $n+1$ nodes and m leaf nodes. The node numbering convention for N and each of its corresponding nodes in the RC tree is as follows:

- 1) The input node, also called datum, is node 0.
- 2) The m leaf nodes are numbered consecutively from 1 to m .
- 3) The remaining $n-m$ nodes, if any, are numbered consecutively from $m+1$ to n .

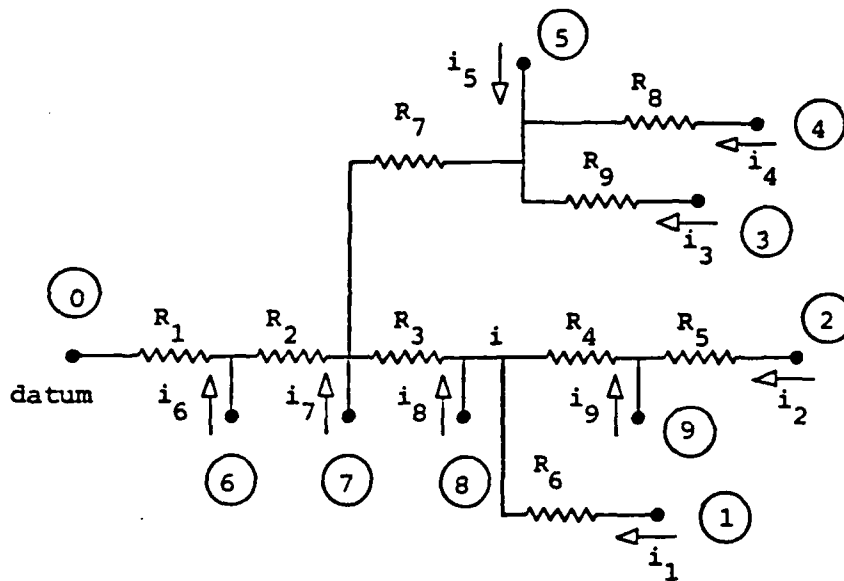

Fig. 3.2 Resistor network N for the tree of Fig. 3.1. Here $n=9$ and $m=4$.

Circuit Parameters and Variables

- 1) $v_k(t)$ is the voltage at node k of the tree, $\forall t \geq 0$, $k \in \{0, 1, \dots, n\}$.
- 2) $i_k(t) \stackrel{\Delta}{=} -C_k \dot{v}_k(t)$.
- 3) $\underline{v}(t)$ is the column n -vector having k th component $v_k(t)$,
 $k \in \{1, 2, \dots, n\}$.
- 4) $\underline{i}(t)$ is the column n -vector having k th component $i_k(t)$,
 $k \in \{1, 2, \dots, n\}$.
- 5) $\underline{0}$ is a column n -vector with all components 0.
- 6) $\underline{1}$ is a column n -vector with all components 1.
- 7) \underline{R} is the resistance matrix of N ; i.e., \underline{R} is such that

$$\underline{v}(t) - \underline{1} v_0(t) = \underline{R} \underline{i}(t) . \quad (3.1)$$

Vector Inequality

A vector is non-negative if and only if all its components are non-negative. Example: $\underline{v}(t) \geq \underline{0}$, $\Leftrightarrow v_k(t) \geq 0$, $\forall k \in \{1, 2, \dots, n\}$.

3.2) Bounding Tree

Definition 3.2

The bounding tree at time $t \geq 0$ is defined as the resistor network N with a voltage source $\hat{v}_0(\lambda(t))$ at datum and a current source $\hat{i}_l(\lambda(t))$ at each leaf node l as shown in Fig. 3.3, where $\lambda(t)$ is the column m -vector with l th component $\lambda_l(t)$, and $\hat{v}_0(\lambda(t))$ and $\hat{i}_l(\lambda(t))$ are given by

$$\hat{i}_l(\lambda(t)) = -\frac{v_i(t) \lambda_l(t)}{R_{il}} , \quad l \in \{1, 2, \dots, m\}$$

and

$$\hat{v}_0(\lambda(t)) = v_i(t) \left(1 - \sum_{l=1}^m \lambda_l(t) \right) .$$

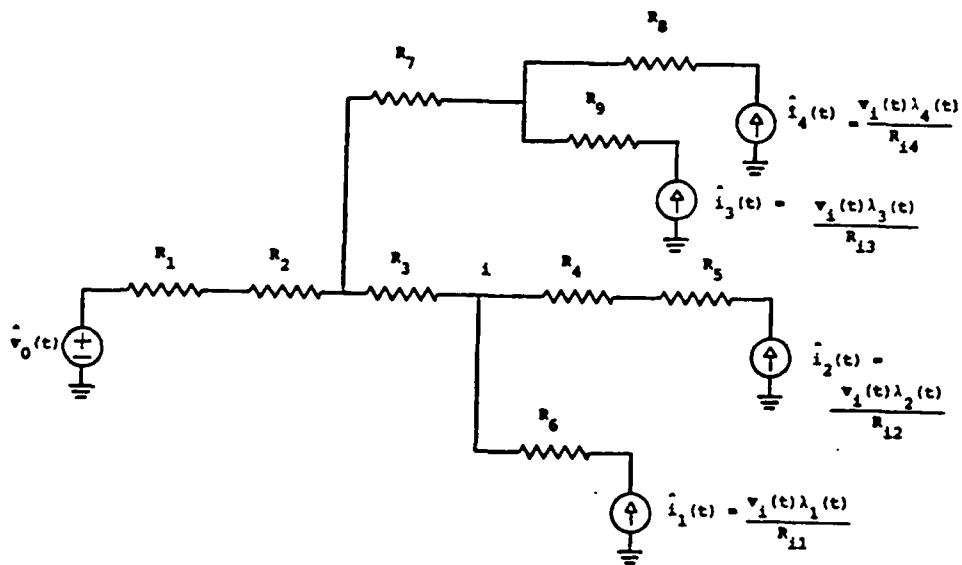

Fig. 3.3 Bounding tree for tree of Fig. 3.1.

The idea of the bounding tree is to extend the concept of the bounding line of section 2.2. In analogy with the improved straight-line bound generated by the bounding line for a $\lambda \in [0,1]$, an improved "straight" bound is generated by the bounding tree for a $\lambda(t)$ in a certain convex region of Euclidean m -space. Then the expression $\sum_k R_{ki} C_k v_k(t)$ is upper bounded by evaluating it using the bounding tree voltage distribution $\{\hat{v}_k(\lambda)\}$ in place of $\{v_k(t)\}$ at the extreme values of λ and finding the maximum. Here, as for the line, it is true that

$$g_i(t) \leq T_{Pi} v_i(t) , \quad (3.2)$$

where

$$T_{Pi} \triangleq \max_{\lambda} \sum_k R_{ki} C_k \hat{b}_{ki} , \quad (3.3)$$

but it is not true that $v_k \leq \hat{v}_k(\lambda)$ (for all k) when λ takes the extreme value required to produce a maximum in (3.3).

3.3) Bounding Tree Lemma

Here an existence lemma about the bounding tree is stated, but its proof is deferred until section IV.

Lemma 1

Given an RC tree network satisfying the conditions of Theorem 1, let $\hat{v}(\lambda)$ denote the voltage distribution in the corresponding bounding tree as defined in section 3.2. Then there exists a $\lambda(t)$ defined for all $t > 0$ such that

$$\underline{\lambda}(t) \geq \underline{0} ,$$

$$\sum_{\ell=1}^m \lambda_{\ell}(t) \leq 1 ,$$

$$v_k(t) \leq \hat{v}_k(\underline{\lambda}(t)) , \forall k \in \{1, 2, \dots, n\} ,$$

and

$$v_i(t) = \hat{v}_i(\underline{\lambda}(t)) .$$

3.4) Conclusion of Proof of Theorem 1

From Lemma 3.1 we have that

$$\sum_k R_{ki} C_k v_k(t) \leq \sum_k R_{ki} C_k \hat{v}_k(\underline{\lambda}(t)) , \forall t \geq 0 , \quad (3.4)$$

for a $\underline{\lambda}(t)$ that lies in a convex region of Euclidean m -space. Since the right side of (3.4) is an affine function of $\underline{\lambda}(t)$, it can be bounded above by evaluating it for $\underline{\lambda}$ at each corner of this convex region and taking the maximum. There are $m+1$ corners of this region: $\underline{\lambda} = \underline{0}$, and for each $\ell \in \{1, 2, \dots, m\}$, $\underline{\lambda}$ such that $\lambda_{\ell} = 1$ and $\lambda_{k \neq \ell} = 0$. The former corresponds to the voltage source in the bounding tree being "full on" and all the current sources being off. Each of the latter corresponds to current source i_{ℓ} being "full on" and all other sources being off. Evaluating the right side of (3.4) at all $m+1$ corners and finding the maximum gives the time-independent upper bound

$$\sum_k R_{ki} C_k \hat{v}_k(\underline{\lambda}) \leq \max \left\{ \left(\sum_k R_{ki} C_k \right) v_i(t) , \max_{1 \leq \ell \leq m} \left\{ \left(\sum_k R_{ki} C_k \left[\frac{R_{k\ell}}{R_{i\ell}} \right] \right) v_i(t) \right\} \right\} . \quad (3.5)$$

Using (3.4) in (3.5) gives

$$\sum_k R_{ki} C_k v_k(t) \leq T_{Pi} v_i(t), \quad \forall t \geq 0, \quad (3.6)$$

where

$$T_{Pi} \triangleq \max \{ T_{Di}, \max_{1 \leq l < m} \left\{ \sum_k \frac{R_{ki} R_{kl}}{R_{il}} C_k \right\} \}. \quad (3.7)$$

Now consider the case where i is a leaf node. For $l=i$,

$$\begin{aligned} \sum_k \frac{R_{ki} R_{kl}}{R_{il}} C_k &= \sum_k \frac{R_{ki}^2}{R_{ii}} C_k \\ &= T_{Ri} \\ &\leq T_{Di}, \end{aligned} \quad (3.8)$$

since $T_{Ri} \leq T_{Di}$ [Rubinstein, Penfield, and Horowitz, p. 204]. Using (3.8) in (3.7) allows us to eliminate i from the set of leaf nodes the maximum is taken over (if it happens to be in this set); i.e.,

$$T_{Pi} = \max \left\{ T_{Di}, \max_{\substack{1 \leq l < m \\ l \neq i}} \left\{ \sum_k \frac{R_{ki} R_{kl}}{R_{il}} C_k \right\} \right\}. \quad (3.9)$$

Equation (3.6) is a state constraint of the form used in the Penfield bounds (except for the falling step input convention); it is through this constraint only that the original T_p constant appears in the derivation of the bound formulas (except possibly the property $T_p \geq T_{Di}$). Thus, T_{Pi} as given by (3.7) and (3.9), which is used in (3.6) as T_p is used in the original bound derivation, can be used in place of T_p in the bound formulas; note that it has the property $T_{Pi} \geq T_{Di}$.

Two statements in Theorem 1 remain to be proven: 1) $T_{Pi} \leq T_p$, and
 2) strict bound improvement results if $T_{Pi} < T_p$.

Proof that $T_{Pi} \leq T_p$

It is known that $R_{ii}R_{kj} \geq R_{ki}R_{ij}$ [Rubinstein, Penfield, and Horowitz, p. 210]. Changing subscripts gives

$$R_{ki}R_{kl} \leq R_{kk}R_{il} . \quad (3.10)$$

But (3.10) gives

$$\sum_k \left(\frac{R_{ki}R_{kl}}{R_{il}} \right) C_k \leq \sum_k R_{kk} C_k . \quad (3.11)$$

Using (3.11) in (3.7) along with the definition of T_p and the property $T_{Di} \leq T_p$, the result is proven:

$$T_{Pi} \leq T_p . \quad (3.12)$$

Demonstration that if $T_{Pi} < T_p$, Strict Bound Improvement Results

This is shown by noting that there are values of t for which a segment of the state trajectories in the v_i - g_i plane corresponding to the bounds must lie on the constraint [Tan and Wyatt, pp. 2-8]; any strict tightening of the constraint eliminates these trajectories from the set of all possible ones and forces a strict improvement of the bounds.

IV Proof of the Bounding Tree Lemma

4.1) Introduction

In this section Lemma 1 of section III is proven. First it is shown that $\{v_k(t)\}$ in the RC tree can be produced by a circuit consisting of N and non-negative current sources as shown in Fig. 4.1. Next it is shown that this circuit can be transformed, by stages, into one that has the form of the bounding tree, with a voltage source at the input and a current source at each leaf node, but no other sources. Each stage of the transformation never decreases any v_k in N , and always holds v_i constant. It is shown that the resultant source values can be expressed

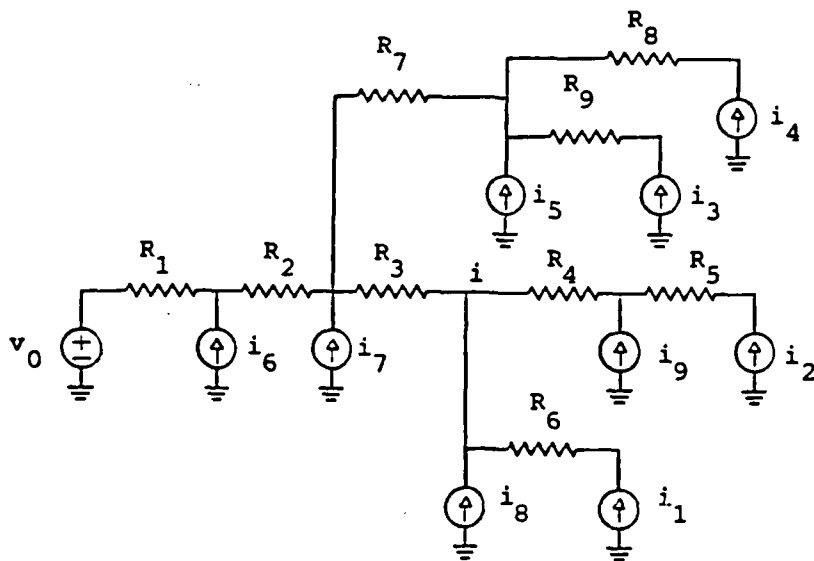

Fig. 4.1 T , the circuit that produces $v(t)$ from N .

in terms of a $\lambda(t)$ having all the properties stated in Lemma 1. From here on, the argument t is dropped from all functions, because we can choose an arbitrary instant of time and then prove the lemma with all functions of t evaluated at that instant.

4.2) Source Replacement

Because of (3.1), N can be made to produce the node voltage distribution \underline{v} by attaching it to current sources and a voltage source as shown in Fig. 4.1. The voltage source has value v_o and the current source for node k has value i_k ; the resulting network is denoted T . Of course

$$\underline{v}_o = 0 . \quad (4.1)$$

From monotonicity of the response [Rubinstein, Penfield, and Horowitz, p. 204],

$$\underline{i} \geq \underline{0} . \quad (4.2)$$

4.3) Proof of Lemma 1 Based on an Algebraic Existence Lemma

It can be seen that the circuit of Fig. 4.1, which produces \underline{v} , has the same form as the bounding tree; only the source values are different. This suggests that the bounding tree lemma can be proven using an algebraic existence lemma. In this section such an existence lemma is stated and used to prove the bounding tree lemma. The existence lemma is proven in a later section.

Notation

- 1) \hat{v}_k is the node k voltage in the bounding tree, $k \in \{0, 1, \dots, n\}$.
- 2) \hat{i}_k is the current feeding into node k of the N subnetwork of the bounding tree, $k \in \{1, 2, \dots, n\}$.
- 3) $\hat{\underline{v}}$ is the column vector for \hat{v}_k , $k \in \{1, 2, \dots, n\}$.
- 4) $\hat{\underline{i}}$ is the column vector for \hat{i}_k , $k \in \{1, 2, \dots, n\}$.
- 5) $\{l\}$ is the set of all leaf nodes.
- 6) $\{j\}$ is the set of all nodes such that $j \neq 0$ and $j \notin \{l\}$.
- 7) \underline{r}_j is the jth column of R.

In the bounding tree, $\hat{i}_j = 0$ for any $j \in \{j\}$; whereas in the actual tree $i_j \geq 0$ and usually $i_j > 0$. If it can be shown that there is a transformation on T such that the current source at any $j \in \{j\}$ is removed and the current sources at the leaf nodes and the voltage source at the input are each held constant or increased, with the result that v_i stays constant and all other voltages don't decrease, then such a transformation can be successively applied to each $j \in \{j\}$, the final result being a bounding tree with non-negative sources, $\hat{\underline{v}} - \underline{v} \geq \underline{0}$, and $\hat{v}_i = v_i$. It is then easily shown that the resultant source values can be expressed in terms of a $\lambda(t)$ as in the lemma statement.

Proof of Existence of Bounding Tree

Define

$$\delta \underline{i} \triangleq \hat{\underline{i}} - \underline{i} . \quad (4.3)$$

From (3.1) and (4.1)

$$\underline{v} = R \underline{i} \quad (4.4)$$

and

$$\underline{\hat{v}} = \underline{1} \underline{\hat{v}}_0 + R \underline{\hat{i}}. \quad (4.5)$$

Equation (4.4) and (4.5) give

$$\begin{aligned} \underline{\hat{v}} - \underline{v} &= \underline{1} \underline{\hat{v}}_0 + R(\underline{\hat{i}} - \underline{i}) \\ &= \underline{1} \underline{\hat{v}}_0 + \sum_{j \in \{j\}} r_j (\hat{i}_j - i_j) \\ &\quad + \sum_{l \in \{l\}} r_l (\hat{i}_l - i_l). \end{aligned} \quad (4.6)$$

The goal is to show that there exists an $\{\underline{\hat{i}}, \underline{\hat{v}}_0\}$ such that all of the following hold:

- i) $\hat{i}_j = 0, \forall j \in \{j\}$.
- ii) $\hat{i}_l \geq 0, \forall l \in \{l\}$.
- iii) $\hat{v}_0 \geq 0$.
- iv) $\hat{v} - v \geq 0$.
- v) $\hat{v}_i = v_i$.

For each $j \in \{j\}$, there exists a leaf node $l(j) \in \{l\}$ such that j is on the path from $l(j)$ to node 0. Given such a mapping from j to $l(j)$, we define $J_l, l \in \{l\}$, to be the set of all nodes $j \in \{j\}$ such that $l(j) = l$. Note that J_l may be empty for some l and that $J_{l_1} \cap J_{l_2} = \{\}$ for $l_1 \neq l_2$. Express i_l and \hat{i}_l in terms of two new variables $i_{l(j),j}$ and $\hat{i}_{l(j),j}$, both indexed by j , as follows:

$$i_l = \sum_{j \in J_l} i_{l(j),j}, \forall l : J_l \neq \{\}. \quad (4.7)$$

and

$$\hat{i}_\ell = \sum_{j \in J_\ell} \hat{i}_{\ell(j),j}, \quad \forall \ell : J_\ell \neq \{ \}. \quad (4.8)$$

We let the variables $\hat{i}_{\ell(j),j}$ be independent and use (4.8) to find \hat{i}_ℓ . On the other hand, i_ℓ is fixed; (4.7) imposes a constraint on the variables $i_{\ell(j),j}$. We can guarantee that (4.7) is satisfied by choosing $i_{\ell(j),j} = i_\ell$ for any $j \in J_\ell$ and $i_{\ell(j),j} = 0$ for all other $j \in J_\ell$. Then:

$$i_{\ell(j),j} \geq 0, \quad \forall j \in J_\ell \neq \{ \}. \quad (4.9)$$

Using (4.7) and (4.8) in (4.6) yields

$$\begin{aligned} \hat{\underline{v}} - \underline{v} = & \underline{1} \hat{\underline{v}}_0 + \sum_{j \in \{j\}} [r_j (\hat{i}_j - i_j) + r_{\ell(j)} (\hat{i}_{\ell(j),j} - i_{\ell(j),j})] \\ & + \sum_{\substack{\ell \in \{\ell\} \\ J_\ell = \{ \}}} [r_\ell (\hat{i}_\ell - i_\ell)], \end{aligned} \quad (4.10)$$

where we have used the facts that the union of the sets J_ℓ for all $\ell \in \{\ell\}$ is $\{j\}$, and J_{ℓ_1} and J_{ℓ_2} are disjoint for $\ell_1 \neq \ell_2$. Assign \hat{i}_j as

$$\hat{i}_j = 0, \quad \forall j \in \{j\}, \quad (4.11)$$

and assign \hat{i}_ℓ (for all $\ell \in \{\ell\}$ such that J_ℓ is empty) as

$$\hat{i}_\ell = i_\ell, \quad \forall \ell \in \{\ell\} \text{ and } J_\ell = \{ \}. \quad (4.12)$$

Using (4.11) and (4.12) in (4.10) gives

$$\hat{\underline{v}} - \underline{v} = \underline{1} \hat{\underline{v}}_0 + \sum_{j \in \{j\}} [-r_j i_j + r_{\ell(j)} \delta i_{\ell(j),j}] \quad (4.13)$$

where

$$\delta i_{\ell(j),j} \stackrel{\Delta}{=} \hat{i}_{\ell(j),j} - i_{\ell(j),j} . \quad (4.14)$$

The only variables remaining to be assigned are \hat{v}_0 and \hat{i}_ℓ for ℓ such that J_ℓ is not empty. The latter will be assigned by choosing $\hat{i}_{\ell(j),j}$ in (4.8). Now the existence lemma is stated; it will be proven in a later section.

Lemma 2

The equation set

$$\frac{1}{r_j} \delta v_0 - r_j i_j + r_{\ell(j)} \delta i_{\ell(j),j} \geq 0$$

$$\delta v_0 - R_{ij} i_j + R_{i\ell(j)} \delta i_{\ell(j),j} = 0$$

has a solution $\{\delta v_0, \delta i_{\ell(j),j}\} \geq 0$ for each $j \in \{j\}$.

If $\{j\}$ is empty, simply assign $\hat{v}_0 = 0$. If $\{j\}$ is not empty, then, by using Lemma 2 in (4.13), we see that there exists a

$\{\hat{v}_0, \{\delta i_{\ell(j),j}\}_{\forall j \in \{j\}}\}$ such that

$$\delta i_{\ell(j),j} \geq 0, \forall j \in \{j\}, \quad (4.15)$$

$$\hat{v}_0 \geq 0, \quad (4.16)$$

$$\hat{v} - v \geq 0, \quad (4.17)$$

and

$$\hat{v}_i = v_i . \quad (4.18)$$

Property i) is proven with (4.11). Property ii) is proven for $\ell : J_\ell = \{ \}$ with (4.2) and (4.12); and it is proven for $\ell : J_\ell \neq \{ \}$ with (4.8), (4.9), (4.14), and (4.15). Properties iii), iv), and v) are proven with

(4.16), (4.17), and (4.18), respectively. This concludes the proof of the existence of a bounding tree with properties i) through v).

Proof of Existence of λ and its Associated Properties

Here the source values corresponding to the bounding tree of section III are denoted by $\hat{v}_0(\lambda)$ and $\hat{i}_\ell(\lambda)$ to distinguish them from those of the bounding tree shown to exist in this section (which are denoted by \hat{v}_0 and \hat{i}_ℓ). To complete the proof of Lemma 1, it will be shown that λ can be chosen, with all the properties stated in the lemma, so that the corresponding source values are equal.

The bounding tree current source values given in section III can be written as

$$\hat{i}_\ell(\lambda) = \frac{v_i \lambda_\ell}{R_{i\ell}}, \quad \forall \ell \in \{\ell\}. \quad (4.19)$$

Since $R_{i\ell} > 0$, (4.19) shows that there exists a $\lambda_\ell \geq 0$ for each $\ell \in \{\ell\}$ such that

$$\hat{i}_\ell(\lambda) = \hat{i}_\ell; \quad (4.20)$$

this defines λ , which is such that

$$\lambda \geq 0. \quad (4.21)$$

We can write

$$\hat{v}_i = \hat{v}_0 + \sum_{\ell \in \{\ell\}} R_{i\ell} \hat{i}_\ell. \quad (4.22)$$

Equations (4.19), (4.20), and (4.22) yield

$$\hat{v}_0 = \hat{v}_i - \sum_{\ell \in \{\ell\}} v_i \lambda_\ell. \quad (4.23)$$

From property v), (4.23) yields

$$\hat{v}_0 = v_i (1 - \sum_{\ell \in \{l\}} \lambda_\ell) . \quad (4.24)$$

Thus

$$\hat{v}_0 = \hat{v}_0(\lambda) . \quad (4.25)$$

Since $\hat{v}_0 \geq 0$ (property iii)) and $v_i > 0$, (4.24) yields

$$\sum_{\ell \in \{l\}} \lambda_\ell \leq 1 . \quad (4.26)$$

Equations (4.20), (4.21), (4.25), and (4.26) together prove that the bounding tree in this section, with properties i) through v), has source values expressible in terms of λ with all the properties stated in Lemma 1, given that Lemma 2 is true.

4.4) Proof of Lemma 2

There are two cases: 1) j is on the line from node i to node 0 inclusive, and 2) j is not on the line from node i to node 0 inclusive. In each case a solution to the equation set is given and shown to have the stated properties. A circuit interpretation of each case is given.

Case 1

Node j is on the line from node i to node 0 inclusive.

Choose

$$\delta v_0 = R_{jj} i_j \quad (4.27)$$

and

$$\delta i_{\ell(j),j} = 0 . \quad (4.28)$$

From (4.2), (4.27), and (4.28),

$$(\delta v_o, \delta i_{\ell(j),j}) \geq 0 . \quad (4.30)$$

From (4.27) and (4.28),

$$\begin{aligned} \frac{1}{-} \delta v_o - \frac{r_j}{-} i_j + \frac{r_{\ell(j)}}{-} \delta i_{\ell(j),j} = \\ \frac{(1 R_{jj} - r_j)}{-} i_j . \end{aligned} \quad (4.31)$$

in general [Rubinstein, Penfield, and Horowitz, p. 204]

$$R_{kj} \leq R_{jj} . \quad (4.32)$$

Equations (4.2), (4.31), and (4.32) yield

$$\frac{1}{-} \delta v_o - \frac{r_j}{-} i_j + \frac{r_{\ell(j)}}{-} \delta i_{\ell(j),j} \geq \frac{0}{-} . \quad (4.33)$$

The case 1 condition means that

$$R_{ij} = R_{jj} . \quad (4.34)$$

From (4.31) and (4.34),

$$\delta v_o - R_{ij} i_j + R_{i\ell(j)} \delta i_{\ell(j),j} = 0 . \quad (4.35)$$

Equations (4.30), (4.33), and (4.35) prove case 1 of Lemma 2.

Circuit Interpretation of Case 1

Figure 4.2a) shows a typical network T for an RC tree at a fixed time. Figure 4.2b) shows a transformation of T in which the current source at

node $j \in \{j\}$ is removed from T and the voltage source is increased. The node voltages for both circuits are shown in Fig. 4.2c). Note that the removal of i_j from T decreases the slopes for all branches between 0 and j , but leaves all other slopes unchanged. This means that v_0 must increase to keep v_i unchanged. If we denote the $\{v_k\}$'s of the original and transformed T by $\{v_{k(\text{before})}\}$ and $\{v_{k(\text{after})}\}$, respectively, then $v_{k(\text{after})} \geq v_{k(\text{before})}$ for all k . Note that this transformation

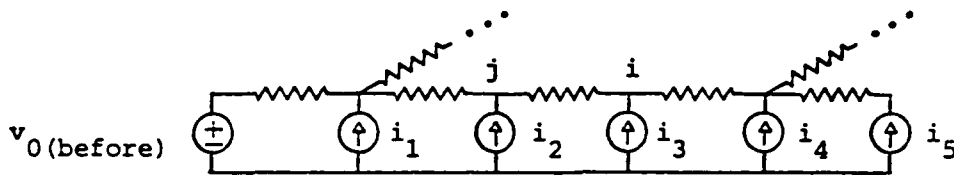

Fig. 4.2a) T for an RC tree at a fixed time (for case 1).

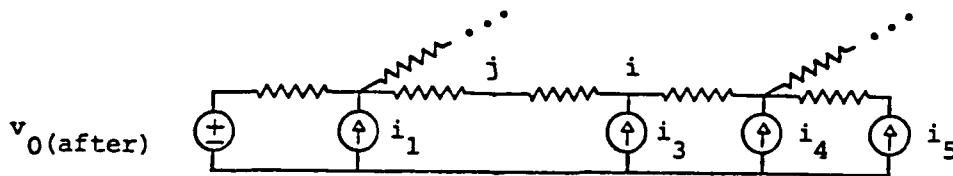

Fig. 4.2b) Transformed T for case 1.

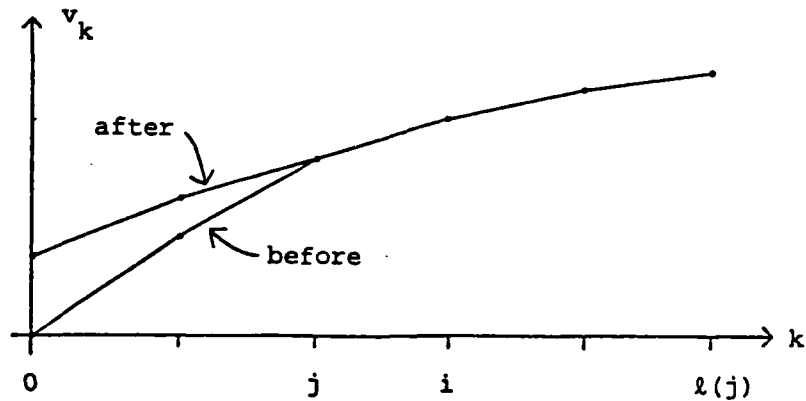

Fig. 4.2c) v_k for original and transformed T of Figs 4.2a) and 4.2b).

can be applied successively until all of the current sources i_j on the line from node i to the source, including i itself, are gone; this was done when Lemma 2 was used.

Case 2

Node j is not on the line from node i to node 0 inclusive.

Choose

$$\delta v_o = 0 \quad (4.36)$$

and

$$\delta i_{l(j),j} = i_j . \quad (4.37)$$

From (4.2), (4.36), and (4.37),

$$(\delta v_o, \delta i_{l(j),j}) \geq 0 . \quad (4.38)$$

From (4.36) and (4.37),

$$\begin{aligned} \frac{1}{r_o} \delta v_o - \frac{r_j}{r_j} i_j + \frac{r_{l(j)}}{r_{l(j)}} \delta i_{l(j),j} = \\ (\frac{r_{l(j)}}{r_{l(j)}} - \frac{r_j}{r_j}) i_j . \end{aligned} \quad (4.39)$$

Since j is on the line from $l(j)$ to 0,

$$R_{il(j)} \geq R_{ij} . \quad (4.40)$$

Equations (4.2), (4.39), and (4.40) yield

$$\frac{1}{r_o} \delta v_o - \frac{r_j}{r_j} i_j + \frac{r_{l(j)}}{r_{l(j)}} \delta i_{l(j),j} \geq 0 . \quad (4.41)$$

The path from $l(j)$ to 0 can be divided into a path consisting entirely of nodes in common with the path from i to 0 and a path containing no nodes on the path from i to 0. Node j is on the latter path by the case 2 condition; this means that

$$R_{ij} = R_{il(j)} \quad (4.42)$$

Equations (4.39) and (4.42) yield

$$\frac{1}{z} \delta v_o - R_{ij} i_j + R_{il(j)} \delta i_{l(j),j} = 0 \quad (4.43)$$

Equations (4.38), (4.41), (4.43) prove case 2 of Lemma 2.

Circuit Interpretation of Case 2

Figure 4.3b) shows a transformation of the T of Fig. 4.3a) in which the current source at j is removed and an equivalent source is added to $l(j)$. Fig. 4.3c) shows the voltage distribution for both T and its

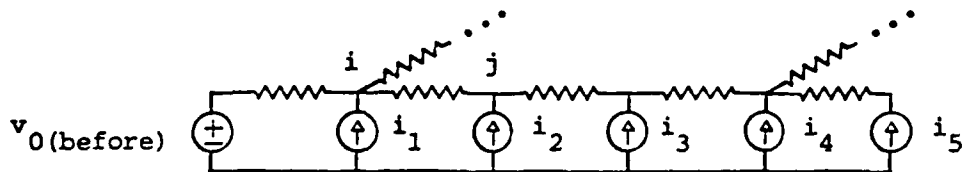

Fig. 4.3a) T for an RC tree at a fixed time (for case 2).

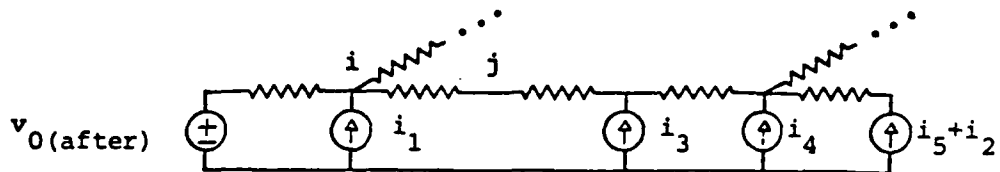

Fig. 4.3b) Transformed T for case 2.

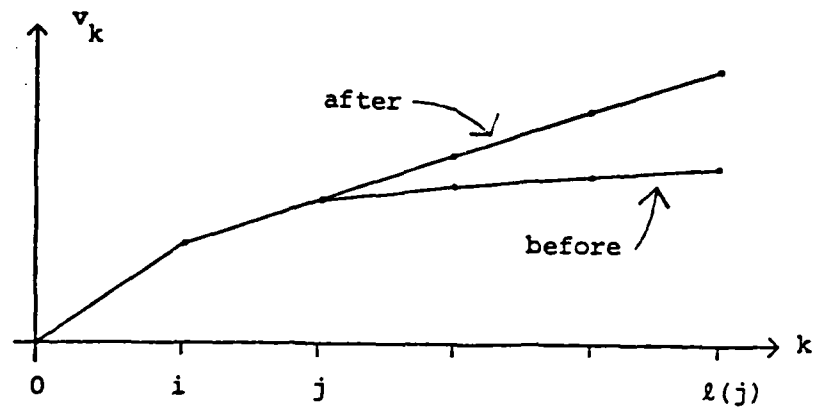

Fig. 4.3c) v_k for original and transformed T of Figs. 4.3a) and 4.3b).

transformed circuit. Note that the slopes increase for all branches between j and $l(j)$ but remain the same for all other branches. Note that v_i is unchanged, and $v_{k(\text{after})} \geq v_{k(\text{before})}$ for all k . The transformation can be applied until all the current sources i_j (such that $j \in \{j\}$ and j satisfies case 2) are gone.

References

- [Horowitz] M.A. Horowitz, "Timing Models for MOS Circuits", Technical Report No. SEL83-003, Stanford University, December 1983, p. 22.
- [Nabors] K. Nabors; Masters Thesis Proposal, MIT, September 1984, pp. 1-10.
- [Rubinstein, Penfield,
and Horowitz] J. Rubinstein, P. Penfield, and M.A. Horowitz, "Signal Delay in RC Tree Networks", IEEE Transactions on Computer-Aided Design, vol. CAD-2, no. 3, July 1983, pp. 202-211.
- [Tan and Wyatt] H. Tan and J.L. Wyatt, Jr., "Time Optimal Trajectories Associated with Voltage Bounds in RC Tree Networks", VLSI Memo No. 84-205, MIT, October 1984, pp. 2-8.

END

DTIC

8-86