



AD-A170 447

2

C³ AUTOMATED PLANNING AND MANAGEMENT INFORMATION SYSTEM
METHODOLOGY STUDY

LIEUTENANT COLONEL L.W.WILSON
DEPUTY CHIEF OF STAFF FOR PLANS
DEVELOPMENT CENTER
MARINE CORPS DEVELOPMENT AND EDUCATION COMMAND
QUANTICO, VIRGINIA 22134-5080

MAY 1986

DTIC
ELECTE
JUN 12 1986
S D D

UNLIMITED DISTRIBUTION

DISTRIBUTION STATEMENT A

Approved for public release
Distribution Unlimited

COMMANDANT OF THE MARINE CORPS
CODE RD
HEADQUARTERS, U.S.MARINE CORPS
WASHINGTON D.C. 20380

DTIC FILE COPY

86 6 12 011



DEPARTMENT OF THE NAVY
HEADQUARTERS UNITED STATES MARINE CORPS
WASHINGTON, D.C. 20380

RD/CCTR-63
SCN: DM 411056

1 MAY 1986

From: Commandant of the Marine Corps

Subj: C3 AUTOMATED PLANNING AND MANAGEMENT INFORMATION SYSTEM
METHODOLOGY STUDY

1. The study objective was to develop a methodology for acquiring a C3 Automated Planning and Management Information System (C3APMIS). The methodology was to ensure that the specification and design of the system would be technically and economically feasible and that the result would be responsive to documented user requirements in the area of acquisition project management.
2. The study objective has been met. The study provides a foundation for further user requirement evaluation, analysis, and implementation of a Mission Element Needs Statement (MENS) for this system. The final report is recommended for distribution.
3. The recommended course of action of the study is deferred. The study is approved as a basis for future testing and evaluation with the proviso that existing low cost acquisition management systems be used to satisfy immediate user requirements until such time as the Justification for Systems New Start (JSNS) be staffed as the Mission Element Needs Statement (MENS) for this system.
4. A copy of this letter will be affixed inside the front cover of each copy of the subject study report prior to its distribution.

Distribution:

DTIC (2) ~~1~~
CNA (2)
CG FMFPAC (6)
CG FMFLANT (6)
CG MCDEC (DevCtr - 4)
(EdCtr - 2)
CMC (M-1) (4)
CMC (LMA) (2)
CMC (CC) (4)

RAY "M" ...
Major General, United States Marine Corps
Deputy ... for RD&S

UNCLASSIFIED

SECURITY CLASSIFICATION OF THIS PAGE

AD-A170 447

REPORT DOCUMENTATION PAGE

1a REPORT SECURITY CLASSIFICATION UNCLASSIFIED		1b RESTRICTIVE MARKINGS None	
2a SECURITY CLASSIFICATION AUTHORITY N/A		3 DISTRIBUTION/AVAILABILITY OF REPORT Unlimited	
2b DECLASSIFICATION/DOWNGRADING SCHEDULE N/A			
4 PERFORMING ORGANIZATION REPORT NUMBER(S)		5 MONITORING ORGANIZATION REPORT NUMBER(S) CMC/RDS-40-86-1	
6a NAME OF PERFORMING ORGANIZATION Electrospace Systems Inc.	6b OFFICE SYMBOL (if applicable)	7a NAME OF MONITORING ORGANIZATION Commandant of the Marine Corps	
6c ADDRESS (City, State, and ZIP Code) 1725 Jefferson Davis Hwy., Suite 501 Arlington, Virginia 22202		7b ADDRESS (City, State, and ZIP Code) Headquarters U.S. Marine Corps Code RDS-40 Washington, D.C. 20380-0001	
8a NAME OF FUNDING/SPONSORING ORGANIZATION Plans Division	8b OFFICE SYMBOL (if applicable) D081	9. PROCUREMENT INSTRUMENT IDENTIFICATION NUMBER M00027-84-D-0033	
8c ADDRESS (City, State, and ZIP Code) Development Center MCDEC Quantico Virginia 22134-5080		10 SOURCE OF FUNDING NUMBERS	
		PROGRAM ELEMENT NO 65151	PROJECT NO C0030
11 TITLE (Include Security Classification) (U) C3 AUTOMATED PLANNING AND MANAGEMENT INFORMATION SYSTEM METHODOLOGY STUDY			
12 PERSONAL AUTHOR(S) Burgess, R.S.; Becker, W.A.; Poppe, C.R.; Arata, H.J.			
13a. TYPE OF REPORT Final	13b TIME COVERED FROM 1984 TO 1985	14 DATE OF REPORT (Year, Month, Day) 860501	15 PAGE COUNT 128
16 SUPPLEMENTARY NOTATION			
17 COSATI CODES		18. SUBJECT TERMS (Continue on reverse if necessary and identify by block number) C3, Methodology, Automated, Information, System	
FIELD	GROUP SUB-GROUP		
19 ABSTRACT (Continue on reverse if necessary and identify by block number)			
<p>(C3)</p> <p>Planning and managing the development of command, control and communications systems is a complex, multi-dimensional task affected by many variables. Several attempts have been made to provide planners with a frame of reference against which to target and manage their efforts. Each of these efforts has been done manually without benefit of an automated model to address the dynamic nature of C3 developmental environment. Manual efforts to update our plans have not been adequate. This study will serve as a precursor effort to development of an automated planning and management system. It identifies and establishes the methodology for a C3 automated planning and management information system. This methodology ensures that the system addresses specific user needs, and that the system specifications and design is both technically and economically feasible.</p>			
20 DISTRIBUTION/AVAILABILITY OF ABSTRACT <input checked="" type="checkbox"/> UNCLASSIFIED/UNLIMITED <input type="checkbox"/> SAME AS RPT <input type="checkbox"/> DTIC USERS		21 ABSTRACT SECURITY CLASSIFICATION UNCLASSIFIED	
22a NAME OF RESPONSIBLE INDIVIDUAL Lt. Col. L. W. Wilson		22b TELEPHONE (Include Area Code) 703-640-3321	22c OFFICE SYMBOL D081

DD FORM 1473, 84 MAR

83 APR edition may be used until exhausted
All other editions are obsolete

SECURITY CLASSIFICATION OF THIS PAGE

UNCLASSIFIED

EXECUTIVE SUMMARY

The purpose of this effort was to research and develop a methodology for acquiring a C³ Automated Planning and Management Information System (C³APMIS). The objective of the methodology is to ensure that the specification and design of the system would be technically and economically feasible, and that the result would be responsive to documented user requirements. The study confirmed the need and provides the most cost effective solution through an evolutionary acquisition of a system which builds on existing capabilities and ongoing projects.

The attached group of documents consolidates and updates the preliminary work and includes the final requirements of a Prototype System Specification and a Statement of Work. The document set is structured to be used by the Marine Corps in obtaining and managing a C³APMIS Integration Support Contractor. It includes all of the documentation specified for the initiation and acquisition of the required automated information system.

Several surveys were conducted as part of this effort. Project management personnel at Headquarters, Marine Corps (HQMC) and the Marine Corps Development and Education Command (MCDEC) were interviewed in order to accurately define the need. The interviews also confirmed the acceptability of an automated system and identified the information elements needed to create the data bases. A survey was also conducted to identify equipment and software currently in the USMC inventory or commercially available which could be used in the C³APMIS design specifications.

The results of the surveys showed universal agreement on the need for an automated decision support capability to assist in C³ acquisition planning and project management tasks. The key requirement and benefit is the ability of all participants to share, on a real-time basis, data which is



Distribution/	
Availability Codes	
Dist	Avail and/or Special
A-1	

now fragmented and available only to individual participants. This includes information now resident in Marine Corps Class I Automated Information Systems. The surveys also showed that the C³APMIS could essentially be developed using hardware and software already used in the Marine Corps and that the system could be implemented with the existing End User Computing (EUC) Guidelines ↙

The study identified several on-going efforts within the Marine Corps, most notably at MCDEC and HQMC, which already address part of the requirements of C⁴SysDiv in the area of acquisition project management. The Prototype System Specification and SOW build upon these efforts, thereby averting the need to begin a long-term development effort for a C³APMIS. This recommended course of action substantially minimizes financial, technical, and time risks.

The Prototype System Specification translated identified user requirements into logical groupings of activities in a baseline functional specification and then describes detailed hardware and software specifications. The SOW provides direction for an Integration Support Contractor to implement a prototype C³APMIS based upon the Prototype System Specification. The prototype will include a microcomputer based local area network in Code CCT which will have the capability to directly access selected Class I AIS data bases. The prototype will demonstrate the capability of an automated system to provide C³ acquisition project management support. It will also provide the basis for final design of a follow-on, mature system in conformance with OMB Circular A-109.

STATEMENT OF WORK

TABLE OF CONTENTS

<u>Section</u>	<u>Page</u>
1.0 SCOPE	1
1.1 Background	1
2.0 APPLICABLE DOCUMENTS	2
2.1 Specification	2
2.2 References	2
3.0 REQUIREMENTS	3
3.1 General	3
3.2 Task 1	8
3.3 Task 2	8
3.4 Task 2.1	8
3.5 Task 2.2	10
3.6 Task 2.2.1	12
3.7 Task 2.2.2	12
3.8 Task 2.3	13
3.9 Task 2.4	13
3.10 Task 3	16
3.11 Task 4	16
3.12 Task 5	16
3.13 Task 5.1	17
3.14 Task 5.2	17
3.15 Task 6	17
3.16 Task 7	18
3.17 Task 8	18
4.0 SCHEDULE OF DELIVERABLES	19
5.0 SUMMARY OF DELIVERABLES	20

LIST OF FIGURES

<u>Title</u>	<u>Page</u>
3.1 Prototype System Network	4
3.2 Acquisition Planning and Management System Information Flow	6
3.3 Requirements Module Data Flow Diagram	9
3.4 Acquisition Management Module Data Flow Diagram	11
3.5 PPBS Sub Module Data Flow Diagram	14
3.6 Resource Allocation Sub Module Data Flow Diagram	15
APPENDIX A Contract Data Requirements List	A-1

STATEMENT OF WORK

1. Scope. The Integration Support Contractor (ISC) shall provide technical, analytical and development assistance to implement an operational prototype C³ Automated Planning and Management Information System (C³APMIS). This system will assist the Acquisition Program Sponsor (APS) and his designated representative, the Acquisition Sponsor Project Officer (ASPO), in those efforts necessary to organize and implement project requirements. The C³APMIS shall be capable of accumulating cost and schedule data, evaluating and reporting status, identifying cost and schedule variances, and performing "what if" analyses for Command, Control, Communications and Computer Systems Division (C⁴SysDiv) acquisition projects.

The implementation of this prototype system will require the ISC to install a local area network (LAN), design data bases, and demonstrate and evaluate the system. The prototype will provide the basis for developing detailed specifications for a follow-on mature system.

1.1. Background. The Director, C⁴SysDiv provides for the planning, directing and coordinating of staff activities on matters relating to command and control, telecommunications and automated information systems. Acting in this capacity, the DirC⁴SysDiv is designated as the APS for the acquisition of Marine Corps C⁴ systems and equipment.

Marine Corps Order (MCO) P5000.10A, Systems Acquisition Management Manual, and MCO P5231.1, Life Cycle Management for Automated Information Systems, prescribe a structured process to manage the acquisition of new systems. Each acquisition project is subject to a series of reviews and decisions at

specific milestones during the acquisition cycle. Each review/decision is dependent on successful completion of specific requirements and supported with comprehensive documentation.

Detailed planning and support for the APS is accomplished primarily through the Acquisition Coordinating Group (ACG) consisting of, as a minimum, an Acquisition Sponsor Project Officer (ASPO), Acquisition Project Officer (APO), Development Coordinator (DC), and Development Project Officer (DPO). ACG members are responsible for project documentation from their functional area. Each ACG member is dependent upon the activities of, and data supplied by, other ACG members. Information is exchanged among ACG members by personal contact, written memoranda/reports, or telephonic means. Presently, ACG members use a combination of manual status tracking and individually developed automated aids. The procurement of automated equipment to improve the acquisition process has been made by individual headquarters staff agencies in limited quantities and on a piecemeal basis. There is virtually no automated capability to exchange data between staffs.

2. Applicable Documents. The following documents provide task guidance and requirements.

2.1 Specification. C3 APMIS Prototype Systems Specification, 6 September 1985 referred to herein as the Prototype Specification (PS).

2.2 References. The following documents provide guidance and background information.

- a. DOD Directive 5000.1, Major System Acquisition
- b. DOD Instruction 5000.2, Major System Acquisition Procedures

- c. SECNAVINST 5000.1, System Acquisition in the Department of the Navy
- d. MCO P5000.10A, Systems Acquisition Management Manual
- e. MCO P5231.1, Life Cycle Management for Automated Information Systems
- f. MCO P5233.1A, ADP Standards Program, Microcomputer Standards (DRAFT)
- g. USMC End User Computing Guidelines, 30 October 1984

3. Requirements. The ISC shall design and implement the prototype C³APMIS, consisting of a LAN within the office spaces of HQMC, Code CCT, and a management information system consisting of two modules and two sub modules which will automate the management process for the acquisition of C⁴ equipment. The ISC will be responsible for selecting hardware and software, establishing interfaces with existing main frame computers, developing operational procedures and demonstrating and evaluating the effectiveness of the C³APMIS. Upon validation of the prototype system, a detailed design specification and cost estimate will be prepared for the follow-on mature C³APMIS.

3.1. General. The prototype system will consist of a microcomputer LAN located within the office space of HQMC, Code CCT with connection to selected Marine Corps main frame computers which provides the ability to extract information from Class I Automated Information System (AIS) data bases, as well as commercial time sharing computer systems currently in use, as depicted in Figure 3.1. The LAN will provide system subscribers the ability to share files and exchange information.

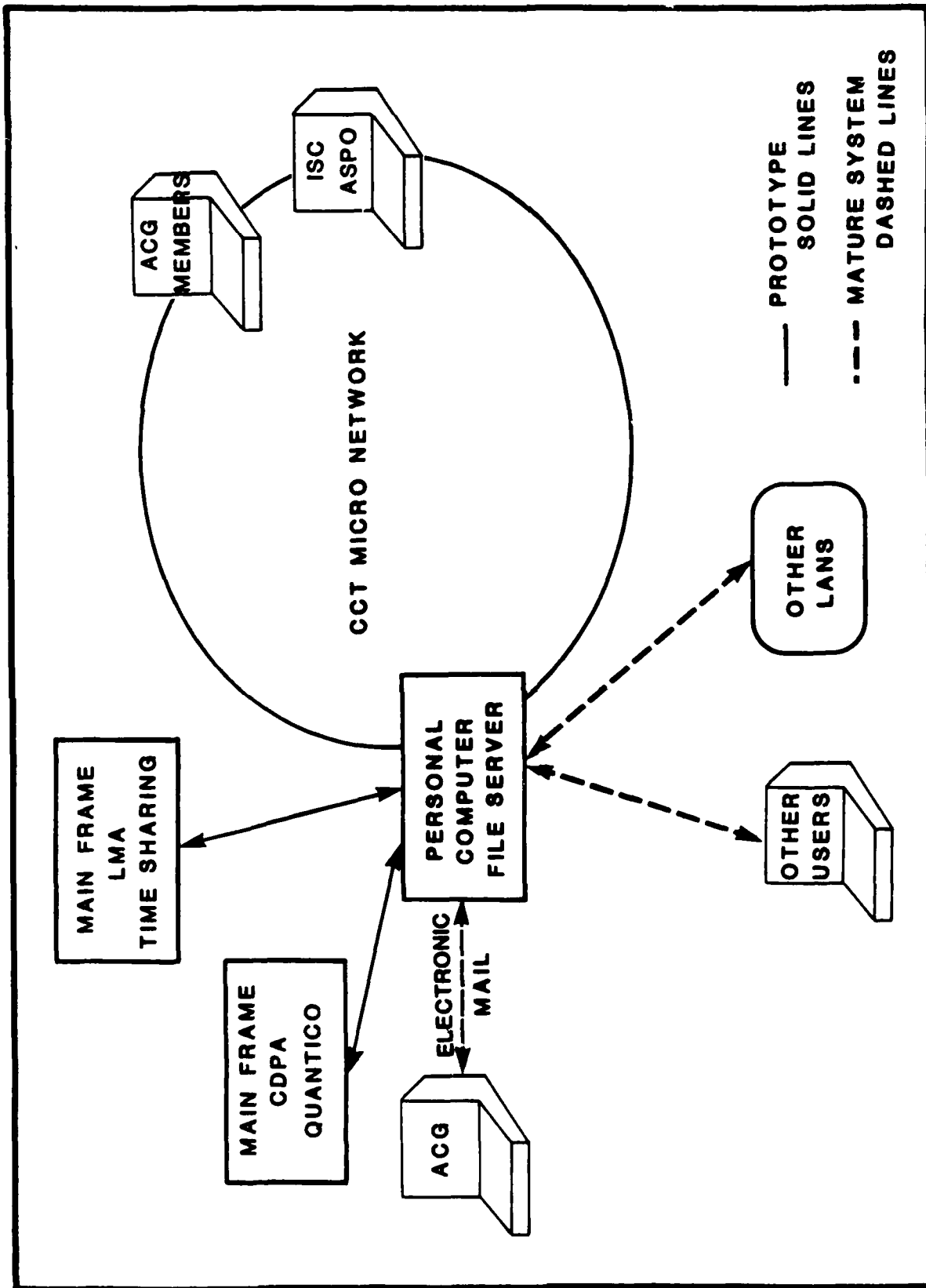

Figure 3.1. Prototype System Network

The prototype system will provide automated management assistance for the acquisition of C⁴ systems and demonstrate the management process as shown in Figure 3.2. This management process will consist of two main modules (Requirements and Acquisition Management), and two sub modules (PPBS and Resource Allocation). These modules provide acquisition management support from the program initiation phase through the production-deployment phase of the acquisition cycle in the areas of requirement identification, planning, and project management. One C⁴ acquisition project will be identified as a model for the demonstration of the prototype C³APMIS. HQMC, Code CCT will provide the ASPO responsible for the selected project to act as the technical representative point-of-contact during the development of the system.

The prototype C³ Automated Planning and Management Information System will not utilize classified information during the demonstration and evaluation of the system. However, it is anticipated that the mature system will process classified and or sensitive data, therefore, consideration must be given during the prototype development for the future application of classified data.

The prototype system requires connection to data bases located at MCCDPA, Quantico. Major Marine Corps automated data processing equipment and software is IBM compatible and uses IBM compatible operating system software. Master data bases at the MCCDPA sites are composed of standard data base elements as defined by DATAMANAGER.

Existing Marine Corps hardware, software and telecommunications assets will be used as much as possible. Substitute hardware and software required to implement the prototype system shall be completely justified by the ISC. Available Marine Corps assets are as follows:

- o HQMC, Code CCT

Hardware

- (1) Three AT&T 6300 Microcomputers with one more on order
 - 512 RAM, one 10M Hard Disc, one 120 cps dot-matrix printer
- (2) Three TEMPEST approved IBM PC-XT on order
 - Two dot matrix and one letter quality printer
- (3) One IBM PC-XT on order

Software

- (1) Word processor: Microsoft Word, Volkswriter Deluxe
- (2) Spread sheet: Lotus 123
- (3) Data base management: dBase II, dBase III
- (4) Scheduler: PERT Master
- (5) Communications software: AT&T 4410 Emulation Package, QMODEM, PC-TALK (IBM 3301 Emulation)
- (6) Graphics: DR Draw and Graph
- (7) 3270 Terminal Emulation

- o Marine Corps Central Design and Programming Activity, Quantico

Hardware

- (1) AMDAHL 470/V8A and 470/V8 CPU
- (2) IBM 4341 Main frame
- (3) NCR COMTEN

(1) Data Base Management System: DATAMANAGER

- o HQMC, Code LMA (Contract Time Sharing)

(1) Project Management: Integrated Management
Planning and Cost Tracking (IMPACT)

3.2 Task 1. Local Area Network Installation. The ISC shall install a LAN internal to Code CCT with connection to selected main frame computers as depicted in Figure 3.1. This includes the physical layout of network components. Network components include all hardware and software necessary to connect workstations within Code CCT using twisted pair wire. Microcomputers and software used for the prototype system shall be selected from the existing Code CCT equipment listed in paragraph 3.1. Network components selected shall meet system requirements as detailed in the PS. System telecommunications requirements for connection to Marine Corps main frame and commercial time sharing computer systems will be satisfied by the use of government owned facilities or leased services. The ISC will effect the necessary coordination to acquire these circuits. (PS Para. 3.2, 3.3, 3.4)

3.3 Task 2. Detailed Physical System Design. The ISC shall develop the detailed physical systems design in accordance with the PS. The physical design of the system shall include the creation of files, data bases, data entry formats, and a data dictionary. A C⁴ acquisition project will be automated to demonstrate the system modules in support of the acquisition management process as shown in Figure 3.2. (PS Para. 2.2) (CDRL 0001)

3.4 Task 2.1 Requirements Module. The Requirements Module (Figure 3.3) provides for the collection and review of supporting data to justify project new starts, and assists the APS to identify new operational

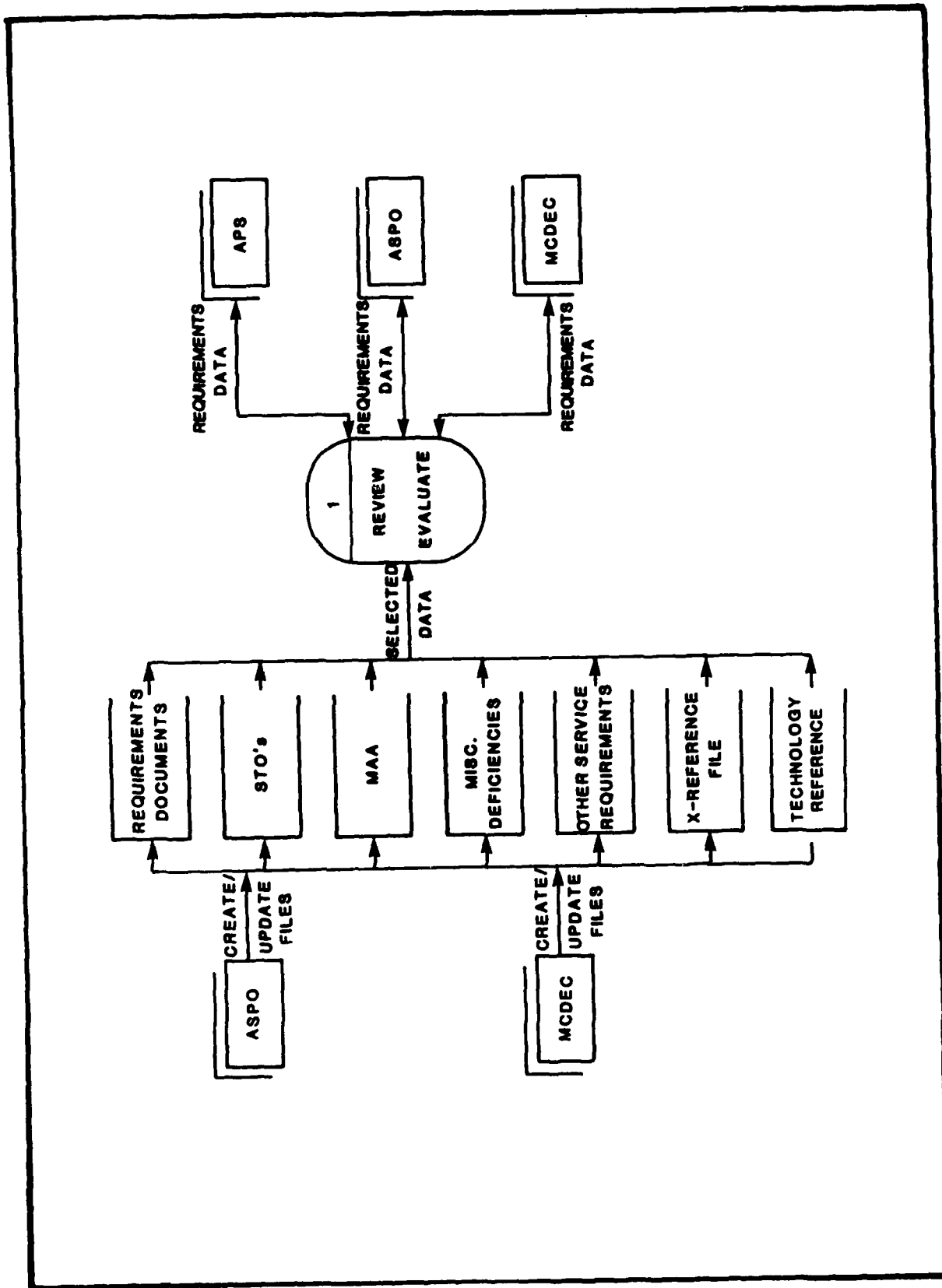

Figure 3.3. Requirements Module Data Flow Diagram

requirements or existing deficiencies. The processes of review and evaluation of requirements, new technologies and deficiencies are the primary functions of this module. This module will consist of seven files as follows:

- o Requirements Documents File (PS Para. 2.2.1.1)
- o Science and Technology Objectives (STO) File (PS Para. 2.2.1.2)
- o Mission Area Analysis (MAA) File (PS Para. 2.2.1.3)
- o Miscellaneous Deficiencies File (PS Para. 2.2.1.4)
- o Other Service Requirements File (PS Para. 2.2.1.5)
- o Cross Reference File (PS Para. 2.2.1.6)
- o Technology Reference File (PS Para. 2.2.1.7)

The Requirements Module will be simulated by the ISC during the Prototype System development; however, specifications will be developed in accordance with Task 6 for development of the mature system. (PS Para 2.2.1) (CDRL 0003)

3.5 Task 2.2 Acquisition Management Module. The ISC shall design an Acquisition Management Module to accomplish the planning and scheduling necessary for acquisition management (Figure 3.4). The project management program, software and data bases currently being used by HQMC, Code LMA will be utilized to the greatest extent possible to satisfy the requirements of the Acquisition Management Module. The ISC shall develop this module to utilize previous efforts and maintain compatibility with the project management system developed for Code LMA. The Acquisition Management Module shall be designed to assist the user in constructing a time-

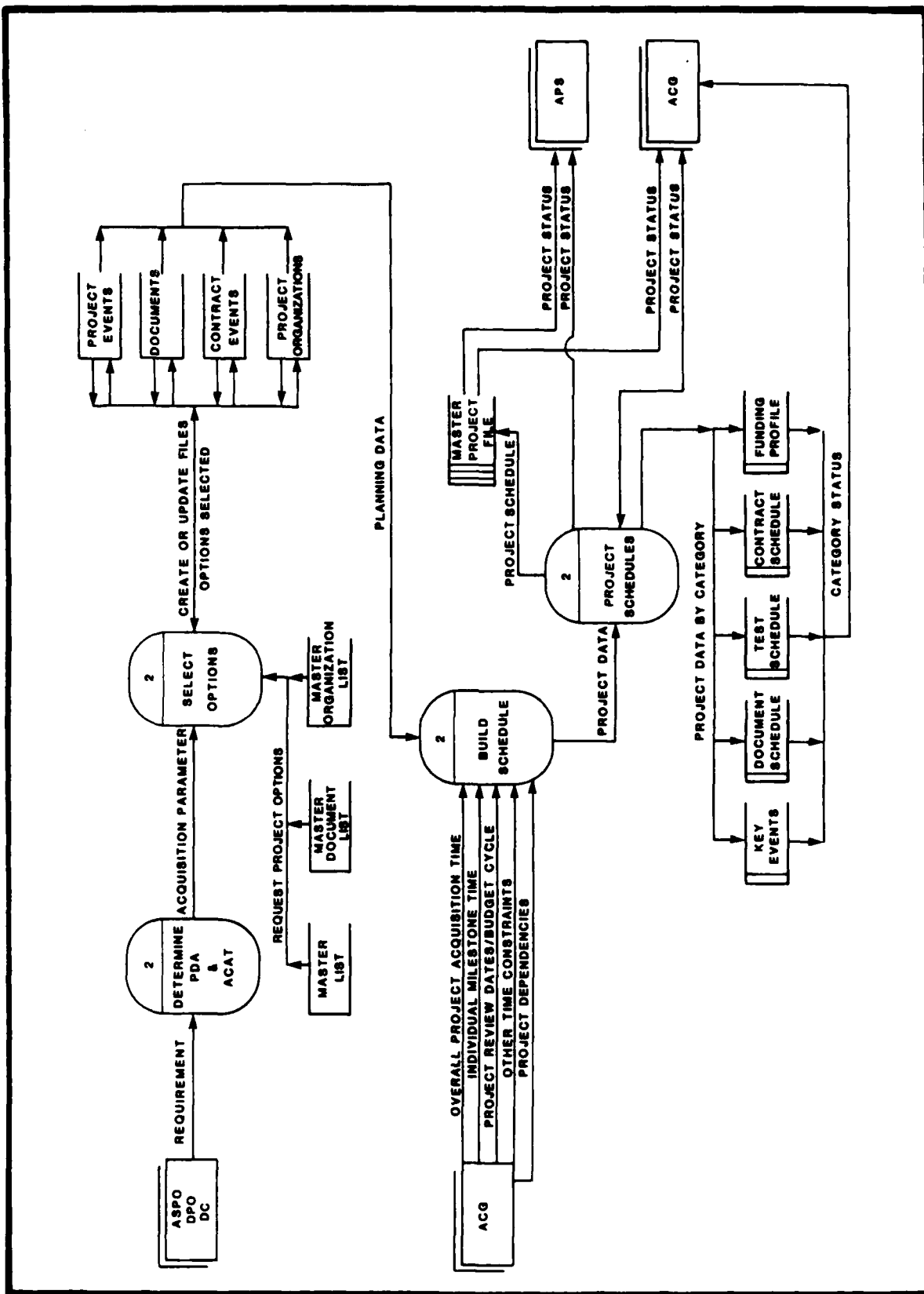

Figure 3.4. Acquisition Management Module Data Flow Diagram

phased dependency network schedule to provide a "What If" capability, and the capability to monitor the planned versus actual progress of projects. The Acquisition Management Module will integrate key project events from all functional and supporting areas, generate project management alternatives, evaluate the impact of management actions, and utilize decision support methodologies to assist the APS and ASPO to exercise control of the acquisition project. (PS Para. 2.2.2) (CDRL 0001)

3.6 Task 2.2.1 Master Data Base Files. The ISC shall develop three Master Data Base Files. These files will contain a listing of generic project events, documentation and organizations that could apply to any acquisition project. A capability shall be developed that by entering the Principal Development Activity (PDA) and the Acquisition Category (ACAT), applicable events, documentation and organizations from the master files can be displayed as candidates for project planning for a given acquisition project as follows: (CDRL 0001)

- o Master Event List File (PS Para. 2.2.2.1)
- o Master Documentation List File (PS Para. 2.2.2.2)
- o Master Organization List File (PS Para. 2.2.2.3)

3.7 Task 2.2.2 Master Project File. The ISC shall design a Master Project File (PS Para. 2.2.2.9). This file, when functional, will contain data from all C⁴ acquisition projects and provide the capability to determine inter-project dependencies and assess the impact of changes in one project upon other projects. Data representing C⁴ acquisition projects other than the project selected for demonstration will be simulated during the development of the prototype system. (CDRL 0001)

3.8 Task 2.3 PPBS Sub Module. This sub module (Figure 3.5) shall be designed to satisfy the requirements of the APS, ASPO, and other ACG members for PPBS related data, primarily current baseline resource requirement profiles and information needed to justify project requirements during the development and procurement process. The ISC shall construct five files as follows: (PS Para. 2.2.3) (CDRL 0001)

- o PMC POM Initiative Data File (PS Para. 2.2.3.1)
- o FYDP File (PS Para. 2.2.3.2)
- o Budget Execution File (PS Para. 2.2.3.3)
- o Budget History File (PS Para. 2.2.3.4)
- o C⁴ Project Priority File (PS Para. 2.2.3.5)

3.9 Task 2.4 Resource Allocation Sub Module. The ISC shall construct a sub module (Figure 3.6) that will allow system users to conduct "What If" analyses concerning the allocation of project resources and assessment of changes in funding or schedule. This module will require interfaces to Marine Corps Class I AIS data bases. Access is required to the Logistics Management Information System (LMIS) and Table of Manpower Requirements (TMR) data bases. The "What If" analysis will be accomplished using commercially available integration software packages. Four files shall be constructed for this module as follows: (PS Para. 2.2.4) (CDRL 0001)

- o Logistic Management Information System (LMIS) Access File (PS Para. 2.2.4.1)
- o Table of Manpower Requirements (TMR) Access File (PS Para. 2.2.4.2)

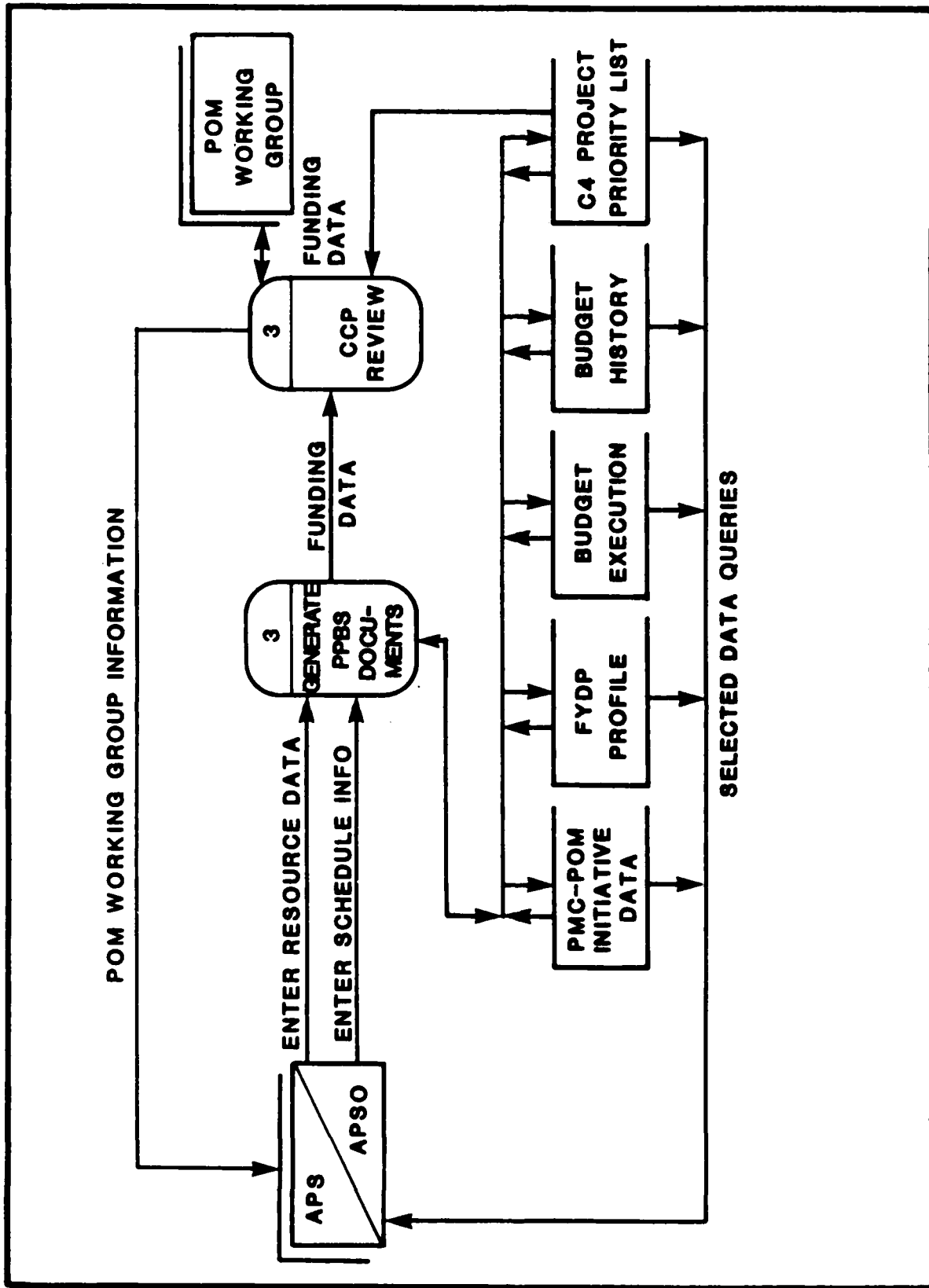

Figure 3.5. PPBS Sub Module Data Flow Diagram

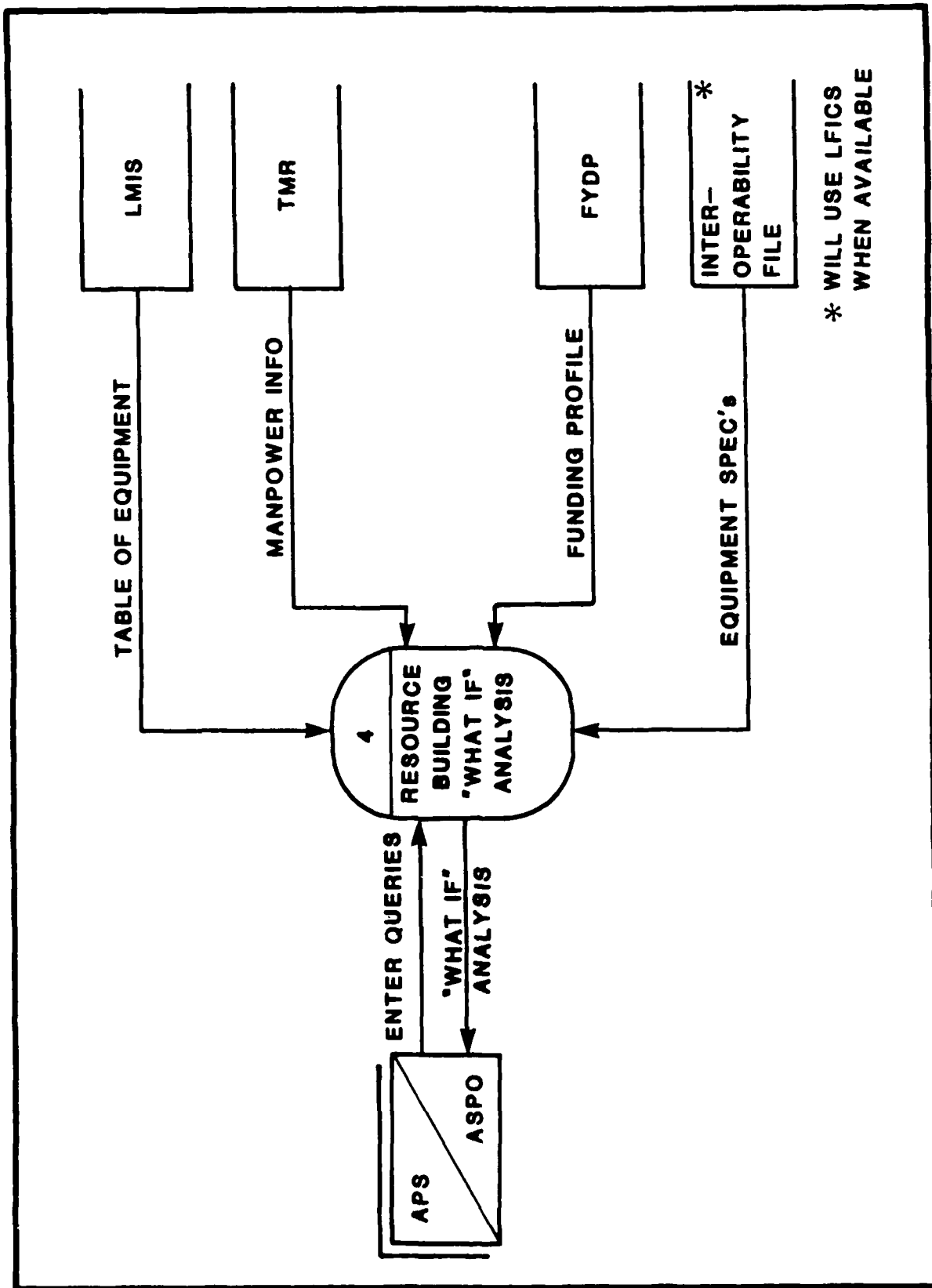

Figure 3.6. Resource Allocation Sub Module Data Flow Diagram

- o FYDP File (PS Para. 2.2.4.3)
- o Interoperability File (PS Para. 2.2.4.4)

3.10 Task 3. Format Development. The ISC shall, in the development of the prototype system create and test screen formats, and design document and report formats for each file (less those simulated modules). The ISC will physically perform the data input responsibilities for the ACG members as listed below during system development, test and evaluation: (CDRL 0002)

<u>MEMBER</u>	<u>RESPONSIBILITY</u>
Acquisition Sponsor Project Officer	System Advocate
Acquisition Project Officer	Supportability
Development Project Officer	RDT&E Management
Development Coordinator	Monitor RDT&E
Manpower Point of Contact	Advise on Manpower
Training Review Officer	Advise on Training

3.11 Task 4. Management Plan. The ISC shall prepare a Prototype C³APMIS Management Plan to be submitted to HQMC, Code CCT within 30 days after contract award. The management plan will detail how the ISC will implement the prototype C³APMIS and include as a minimum the milestone schedule for the "schedule of events" associated with completion and demonstration of SOW tasks. If applicable include government support required. (CDRL 0003)

3.12 Task 5. Demonstration and Evaluation Plan. The ISC will develop test objectives and performance standards to evaluate C³APMIS concept viability, to include:

- a. Demonstration of the acquisition management support capabilities of the prototype system.
- b. Identification of prototype system deficiencies and corrective action required.
- c. Identification of prototype system enhancements and benefits.

The C³APMIS modules will be tested as they are completed. (CDRL 0004)

3.13 Task 5.1 Test Reports. A test report shall be submitted for each module and sub module tested and for the total system demonstration and evaluation. The test reports will consist of data collection and analysis necessary to measure predictive performance standards and test objectives against actual results. The reasons for differences will be explained. (CDRL 0005)

3.14 Task 5.2 Test Scenario. In order to test individual modules and the entire prototype system throughout the acquisition cycle from program initiation to production deployment, event and situation simulation will be necessary. The contractor shall build a test scenario and the performance evaluation standards necessary to evaluate each module and the C³APMIS as a complete system. The scenario and standards shall be submitted for government approval within 60 days after contract award. (CDRL 0004)

3.15 Task 6. Detailed System Specification. The ISC, based on information gained from the prototype system, shall develop a detailed design specification for the mature system. The mature system will include completing the development of the C³APMIS modules demonstrated in the

prototype, developing additional sub modules to assist in trending and forecasting, and extending the local area network to other members of the ACG. (CDRL 0006)

3.16 Task 7. System Support. The ISC shall write system operational procedures for the mature system. This will include Data Administrator and Data Base Manager responsibilities, in addition to system maintenance requirements. (CDRL 0007).

3.17 Task 8 Cost Estimate. The ISC shall develop a cost estimate for the development and subsequent operation of the mature C³ Automated Planning and Management Information System. (CDRL 0008)

4. Schedule of Deliverables

<u>Task</u>	<u>CDRL #</u>	<u>Deliverable</u>	<u>Due Date</u>
1		Local Area Network Installation	60 DAC
2	0001	Detailed Physical System Design	60-180 DAC
2.1	0003	Requirements Module	NOTE 1
2.2	0001	Acquisition Management Module	NOTE 1
2.2.1	0001	Master Data Base Files	NOTE 1
2.2.2	0001	Master Project File	NOTE 1
2.3	0001	PPBS Sub Module	NOTE 1
2.4	0001	Resource Allocation Sub Module	NOTE 1
3	0002	Format Development	60 DAC
4	0003	Management Plan	30 DAC
5	0004	Demonstration and Evaluation Plan	60 DAC
5.1	0005	Test Reports	30 DAYS AFTER COMPLETION OF TEST
5.2	0004	Test Scenarios	60 DAC
6	0006	Detailed System Specification	240 DAC
7	0007	System Support	240 DAC
8	0008	Cost Estimate	240 DAC

NOTE 1: The Integration Support Contractor shall deliver the module and sub modules in sequence commencing 60 DAC and continue at 60 day intervals until completed. The sequence of files shall be determined by the ISC with the actual schedule of delivery included in the Management Plan (Task 4 CDRL 0003).

5. Summary of Deliverables

Requirement	Status				
	Requires				Simulate Only
	Design	Develop	Interface AIS's W/Existing ALS	Test	
Local Area Network Installation	X	X	X	X	
Requirements Module	X				X
1. Requirements Document File	X				X
2. STO File	X				X
3. MAA File	X				X
4. Miscellaneous Information File	X				X
5. Other Services File	X				X
6. Cross Reference File	X				X
7. Technology Reference File	X				X
Acquisition Management Module					
8. Master Event List File				X	X
9. Master Document List File				X	X
10. Master Organization List File	X	X		X	
11. Project Event File					
12. Project Document File				X	X
13. Contract Event File	X	X		X	
14. Project Organizations File					
15. Master Project File					X
PPBS Sub Module					
16. PMC POM Initiative Data File	X	X		X	
17. FYDP File	X	X		X	
18. Budget Execution File	X	X		X	
19. Budget History File	X	X		X	
20. C4 Project Priority File	X	X		X	

5. Summary of Deliverables (Continued)

Requirement	Status				
	Requires				Simulate Only
	Design	Develop	Interface AIS's W/Existing ALS	Test	
Resource Allocation Sub Module					
21. LMS Access File			X	X	
22. TMR Access File		X	X	X	
23. FYDP File	X			X	
24. Interoperability File					X
Format Development	X	X		X	
Management Plan	X	X			
Demonstration and Evaluation Plan	X	X			
Test Reports	X	X			
Test Scenario	X	X			
Detailed System Specification	X	X			
System Support	X	X			
Cost Estimate	X	X			

PROTOTYPE SYSTEM SUPPORT PLAN

TABLE OF CONTENTS

<u>Section</u>	<u>Page</u>
1.0 GENERAL	1-1
1.1 Purpose	1-1
1.2 Project References	1-1
1.2.1 C ³ Automated Planning and Management Information System Documentation	1-1
1.2.2 Reference Documentation	1-1
1.3 Terms and Abbreviations	1-2
1.4 Security	1-3
2.0 SYSTEM SUMMARY	2-1
2.1 System Description	2-1
2.1.1 Existing System	2-1
2.2 System Configuration	2-2
3.0 HARDWARE SUPPORT	3-1
3.1 Hardware Environment	3-1
3.2 Siting Factors	3-2
3.3 Logistics Support	3-2
3.3.1 Maintenance Concept	3-2
3.3.2 Supply Support	3-3
3.3.3 Packaging, Storage, and Transportation	3-3
3.3.4 Documentation	3-3
3.3.5 Configuration Control	3-3
3.4 Accountability	3-3
4.0 SOFTWARE SUPPORT	
4.1 Software Environment	4-1
4.2 Interfaces	4-1
4.3 Program Storage Requirements	4-1
4.4 Configuration Control	4-1
5.0 PERSONNEL/MANPOWER SUPPORT	5-1
5.1 Organizational Impacts	5-1
5.2 Training	5-1
5.3 HQMC, Code CCT, Participation.	5-1

TABLE OF CONTENTS (Continued)

<u>Section</u>	<u>Page</u>
6.0 TELECOMMUNICATIONS SUPPORT	6-1
6.1 Data Transfer Requirements	6-1
6.2 Telecommunications Services	6-1
6.2.1 Equipment	6-1
6.2.2 Responsibilities	6-1
6.2.2.1 ISC	6-1
6.2.2.2 HQMC, Code CCT	6-2
7.0 IMPLEMENTATION CONSIDERATIONS	7-1
7.1 System Implementation Planning Factors	7-1
7.1.1 Personnel	7-1
7.1.2 Organizational Tasks	7-1
7.1.3 Site Preparation	7-1
7.1.4 Material Requirements	7-1
7.1.5 Financial Summary	7-1
7.2 Milestone Schedule	7-1
8.0 TEST SUPPORT REQUIREMENTS	8-1
8.1 Test Program Objectives	8-1
8.2 Test Items	8-1
8.3 Test Activity Description	8-1
8.4 Test Reports	8-2
8.5 Test Support	8-2
9.0 CONTRACTOR SUPPORT	9-1
9.1 Contractor Support Requirements	9-1

LIST OF FIGURES

<u>Title</u>	<u>Page</u>
2.1 Prototype System Network	2-3

SUPPORT PLAN

PROTOTYPE C³ AUTOMATED PLANNING AND MANAGEMENT INFORMATION SYSTEM

SECTION 1. GENERAL

1.1 Purpose. The purpose of the Support Plan (SP) is to identify support requirements for a prototype C³ Automated Planning and Management Information System (C³APMIS) in the areas of hardware, software, personnel, telecommunications, testing, and other implementation considerations.

1.2 Project References. The following documents are applicable to this SP.

1.2.1 C³ Automated Planning and Management Information System Documentation:

- a. Justification for System New Start (JSNS), 6 September 1985
- b. Prototype System Specification, 6 September 1985
- c. Prototype System Statement of Work, 6 September 1985

1.2.2 Reference Documentation:

- a. DOD Directive 5000.1, Major System Acquisition
- b. DOD Instruction 5000.2, Major System Acquisition Procedures
- c. SECNAVINST 5000.1, System Acquisition in the Department of the Navy

- d. MCO P5000.10A, Systems Acquisition Management Manual
- e. MCO P5231.1, Life Cycle Management for Automated Information Systems
- f. MCO P5233.1A, ADP Standards Program, Microcomputer Standards (DRAFT)
- g. USMC End User Computing Guidelines, 30 October 84

1.3 Terms and Abbreviations. The following abbreviations are used in the SP:

ACG	Acquisition Coordinating Group
ADP	Automated Data Processing
ADPE	ADP Equipment
AIS	Automated Information Systems
APO	Acquisition Project Officer
APS	Acquisition Program Sponsor
ASPO	Acquisition Sponsor Project Officer
AT&T	American Telephone and Telegraph
C3	Command, Control and Communications
C ³ APMIS	C3 Automated Planning and Management Information System
DC	Development Coordinator
DOD	Department of Defense
DPO	Development Project Officer
GFE	Government Furnished Equipment
HQMC	Headquarters, Marine Corps
HZ	Hertz
IBM	International Business Machines Corporation
ISC	Integration Support Contractor
JSNS	Justification for System New Start

LAN	Local Area Network
LMIS	Logistics Management Information System
MCCDPA	Marine Corps Central Design and Programming Activity
MCO	Marine Corps Order
MIMMS	Marine Corps Integrated Maintenance Management System
NCR	National Cash Register
PC	Personal Computer
POM	Program Objective Memorandum
PPBS	Planning, Programming, and Budgeting System
SOW	Statement Of Work
TBD	To Be Determined
VAC	Volts Alternating Current

1.4 Security. The SP is unclassified. No classified information will be processed by the prototype C³APMIS.

SECTION 2. SYSTEM SUMMARY

2.1. System Description. The C³APMIS is a management information system which will assist the Acquisition Program Sponsor (APS) and his designated representative, the Acquisition Sponsor Project Officer (ASPO), in those efforts necessary to organize and implement project requirements. The C³APMIS shall be capable of accumulating cost and schedule data, evaluating and reporting status, identifying cost and schedule variances, and performing "what if" analyses for Command, Control, Communications and Computer Systems Division (C⁴SysDiv) acquisition projects.

2.1.1 Existing System. Marine Corps Order (MCO) P5000.10A, System Acquisition Management Manual, and MCO P5231.1, Life Cycle Management for Automated Information Systems, prescribe a structured process to manage the acquisition of new systems. Each acquisition project is subject to a series of reviews and decisions at specific milestones during the acquisition cycle. Each review/decision is dependent on successful completion of specific requirements and is supported with comprehensive documentation. Detailed planning and support for the APS is accomplished through the Acquisition Coordinating Group (ACG) consisting primarily of an ASPO, Acquisition Project Officer (APO), Development Coordinator (DC), and Development Project Officer (DPO). Each ACG member is responsible for maintenance of project documentation from his functional area that pertains to the acquisition project. ACG members are dependent on the activities of, and data supplied by, other ACG members. Information is exchanged among ACG members by personal contact, written memoranda/reports, or telephonic means. Presently, ACG members use a combination of manual status tracking and individually developed automated aids to satisfy acquisition management tasks. Procurement of ADPE has been made on a piecemeal basis by individual staff agencies and there is virtually no automated capability to exchange data between staffs.

2.2 System Configuration. The prototype system will consist of a microcomputer LAN located within the office space of HQMC, Code CCT with connection to selected Marine Corps main frame computers which provides the ability to extract information from Class I Automated Information System (AIS) data bases, as well as commercial time sharing computer systems currently in use, as depicted in Figure 2.1. The LAN will provide system subscribers the ability to share files and exchange information.

The prototype system will provide automated management assistance for the acquisition of C⁴ systems and demonstrate the management process which will consist of two main modules (Requirements and Acquisition Management), and two sub modules (PPBS and Resource Allocation). These modules provide acquisition management support from the program initiation phase through the production-deployment phase of the acquisition cycle in the areas of requirement identification, planning, and project management. One C⁴ acquisition project will be identified as a model for the demonstration of the prototype C³APMIS. HQMC, Code CCT will provide the ASPO responsible for the selected project to act as the technical representative point-of-contact during the development of the system.

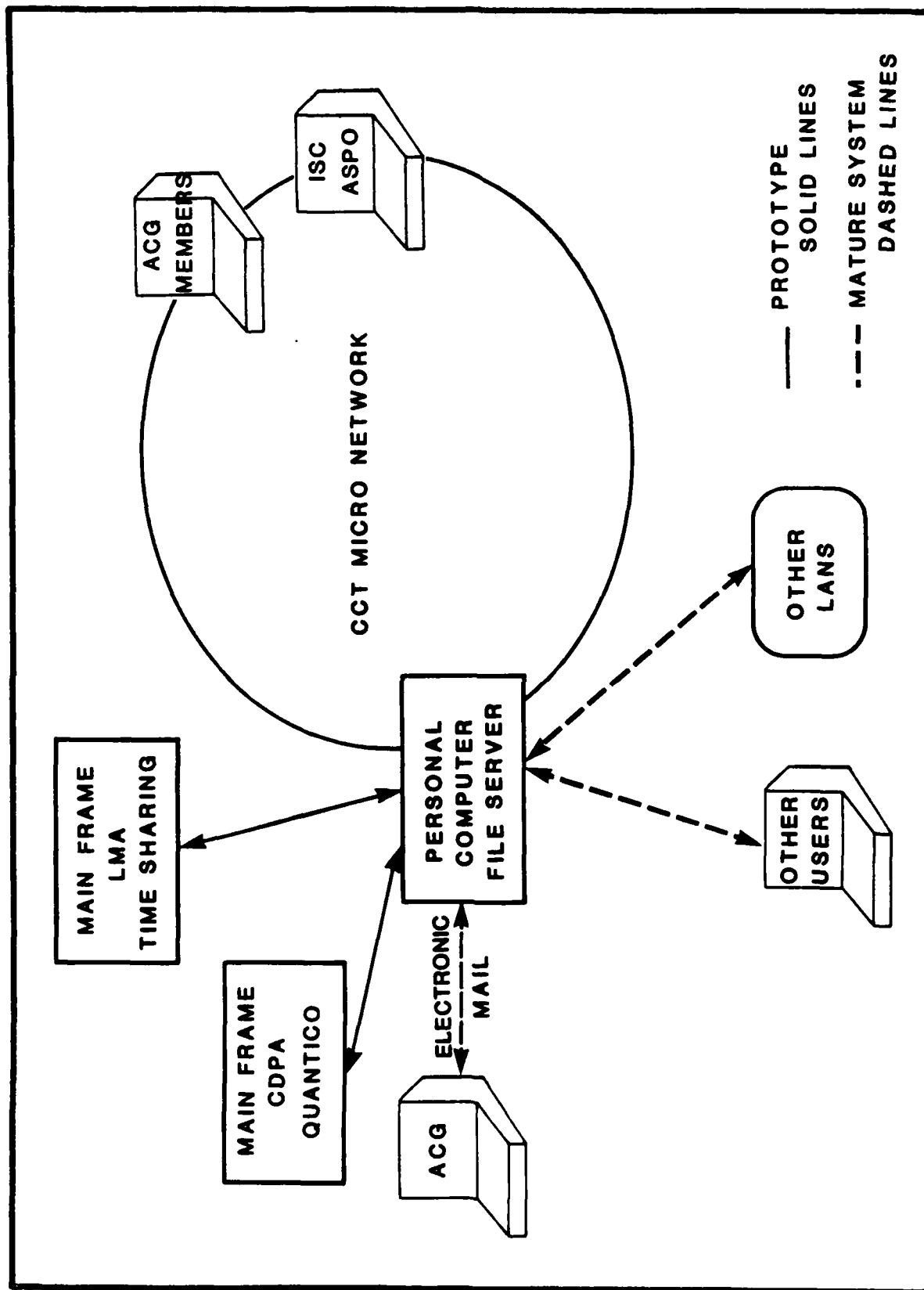

Figure 2.1. Prototype System Network

SECTION 3. HARDWARE SUPPORT

3.1 Hardware Environment

Marine Corps ADPE which supports the major AISs is IBM compatible and uses IBM compatible operating system software. Major data processing facilities operate with Marine Corps controlled standard software. The large master data bases maintained at the MCCDPA sites are composed of standard data base elements. ACG members require information from data bases located at MCCDPA, Quantico.

Hardware available at HQMC, Code CCT, and MCCDPA, Quantico, will be utilized in the prototype C³APMIS. Microcomputers required for the prototype system will be selected from the existing Code CCT equipment listed below. The prototype system will be interconnected with the MCCDPA, Quantico main frame computer equipment listed below. Additional equipment which must be obtained to implement the prototype C³APMIS will be provided by the Integration Support Contractor (ISC).

- o HQMC, Code CCT
 - (1) Three AT&T 6300 Microcomputers, one on order
 - 512K RAM, one 10M Hard Disc, one 120 cps dot-matrix printer
 - (2) Three TEMPEST Approved IBM PC-XT on order
 - Two dot matrix and one letter quality printer
 - (3) One IBM PC-XT (with letter quality printer) on order

- o MCCDPA, Quantico
 - (1) AMDAHL 470/V8A and 470/V8 CPU's
 - (2) IBM 4341 Main Frame
 - (3) NCR COMTEN

3.2 Siting Factors. There are no siting factors for equipment listed in paragraph 3.1, above. For additional equipment required to implement the prototype C³APMIS, the following siting factors are applicable:

- o Equipment must be capable of installation in HQMC, Code CCT work areas on either commonly available tables/desks or specially designed stands which are provided by the equipment vendor.
- o Equipment must operate on standard 60 Hz, 110/120 VAC power.
- o Cabling installed to support the LAN must not interfere with normal work area functions.

3.3 Logistics Support. Existing hardware utilized by the prototype C³APMIS will be supported in accordance with in being procedures. The ISC will satisfy the logistic support requirements listed below for additional equipment provided to implement the prototype C³APMIS.

3.3.1 Maintenance Concept. Maintenance of equipment will be a responsibility of the ISC, but may in-fact be performed by a third-party contractor, such as the equipment vendor, and will include maintenance of any interface devices, connectors, or cabling needed to interface the equipment with GFE system components.

3.3.2 Supply Support. Parts and consumable supplies for equipment will be obtained by the ISC.

3.3.3 Packaging, Storage, and Transportation. The ISC will identify packaging, storage, and transportation requirements or instructions. Physical relocation of equipment by the Government shall not be accomplished without approval of the ISC.

3.3.4 Documentation. No hardware documentation is required for the prototype C³APMIS.

3.3.5 Configuration Control. The ISC will be responsible for configuration management.

3.4 Accountability. The Government shall appoint an individual(s) to be custodian of contractor provided equipment(s). Procedures should be established by the Government to periodically verify equipment presence and condition and to include the equipment in periodic security checks.

SECTION 4. SOFTWARE SUPPORT

4.1 Software Environment. A wide range of Marine Corps and commercial software is available for the C³APMIS and is compatible with the hardware listed in Section 3. Available software packages will be utilized unless alternatives can be fully justified.

Code CCT currently utilizes the following commercial software packages.

- o Word Processor: Microsoft Word, Volkswriter Deluxe
- o Spread sheet: Lotus 123
- o Data Base Management: dBase II, dBase III
- o Scheduler: PERT Master
- o Communications Software: AT&T 4410 Emulation Package, QMODEM, PC-TALK (IBM 3301 Emulation), 3270 Terminal Emulation
- o Graphics: DR Draw and Graph

4.2 Interfaces. Interface with Class I AIS will allow electronic transfer of data resident in existing data bases and eliminate the requirement to manually input data. Access into the LMIS and TMR data bases is required as well as access to the IMPACT data base which supports the HQMC, Code LMA-1, project management main frame time sharing effort.

4.3 Program Storage Requirements. TBD.

4.4 Configuration Control. C³APMIS software maintenance and configuration control will be a responsibility of the ISC. The ISC will develop procedures to process and implement revisions to system software to accommodate changes identified by HQMC, Code CCT, needed to improve the

performance or capability of the prototype C³APMIS. All software developed to support the C³APMIS will become the property of the USMC upon completion of the prototype system integration support contract.

SECTION 5. PERSONNEL/MANPOWER SUPPORT

5.1 Organizational Impacts. Implementation of the prototype C³APMIS will not result in the need for any modification of organizational responsibilities.

5.2 Training. The ISC will be responsible for operation of the prototype C³APMIS. Training for USMC personnel is not required.

5.3 HQMC, Code CCT, Participation. The ASPO responsible for the acquisition project selected for demonstration of the prototype C³APMIS capabilities will act as the Code CCT liaison for the ISC. This individual will provide technical advice to the ISC concerning ASPO responsibilities/requirements and assist as necessary in the development of data input procedures, screen display formats, and standard reports.

SECTION 6. TELECOMMUNICATIONS SUPPORT

6.1 Data Transfer Requirements. TBD by the ISC. In the prototype C³APMIS, data transfer will be required between HQMC, Code CCT, and MCCDPA, Quantico, Va and HQMC, Code CCT and the Code LMA time-sharing facility in Annandale, Va.

6.2 Telecommunications Services. The prototype C³APMIS will require the following telecommunications services.

- o Within HQMC, Code CCT office spaces, the LAN components will be networked utilizing internal house cabling.
- o Connectivity between the HQMC, Code CCT LAN and both the MCCDPA main frame computer at Quantico and the HQMC, Code LMA-1 program management time-sharing main frame computer facility in Annandale, Va.

6.2.1 Equipment. Communications equipment required to implement the HQMC, Code CCT LAN will be provided by the ISC. Communications equipment required to provide the circuits between Code CCT and Quantico and Annandale will be provided by the Government.

6.2.2 Responsibilities. Telecommunications support responsibilities are outlined below.

6.2.2.1 ISC. The ISC will identify the type of telecommunications support needed and the effective dates such support is required. C³APMIS telecommunications equipment will be contractor operated.

6.2.2.2 HQMC, Code CCT. Code CCT will provide telecommunications circuits and or equipment needed to implement the C³APMIS between the Code CCT LAN and Quantico and between the LAN and Annandale.

SECTION 7. IMPLEMENTATION CONSIDERATIONS

7.1 System Implementation Planning Factors. The prototype C³APMIS will be implemented by the ISC. ISC tasks are specified in the prototype C³APMIS Statement of Work. The ISC is required by the SOW to develop a Management Plan which will address implementation requirements.

7.1.1 Personnel. Key contacts for prototype C³APMIS implementation are:

- a. HQMC, Code CCT. LTCOL P. Wilder, 694-1197
- b. HQMC, Code CCTS. TBD
- c. MCCDPA, Quantico. TBD
- d. Integration Support Contractor. TBD
- e. HQMC, Code LMA. TBD

7.1.2 Organizational Tasks. TBD.

7.1.3 Site Preparation. TBD.

7.1.4 Material Requirements. TBD.

7.1.5 Financial Summary. TBD.

7.2 Milestone Schedule. TBD.

SECTION 8. TEST SUPPORT REQUIREMENTS

8.1 Test Program Objectives. The contractor will conduct a Demonstration and Evaluation of the prototype C³APMIS to test system performance. The objectives of the test are as follows:

- o Demonstrate acquisition management support capabilities of the prototype C³APMIS.
- o Identification of prototype system deficiencies and corrective action required.
- o Identification of additional prototype system enhancement and benefits.
- o Provide the basis to develop detailed specifications for a follow-on system.

8.2 Test Items. Prototype C³APMIS LAN hardware will be a combination of contractor and GFE equipment. Additionally, testing will demonstrate the capabilities of each software module and the LAN.

8.3 Test Activity Description. An actual C⁴ project will be used as the acquisition model for demonstration. The contractor will be responsible to conduct the demonstration and evaluation of the C³APMIS. Each of the C³APMIS modules/sub modules will be tested both individually as they are completed and together as an overall system. In order to test individual modules and the entire prototype system across the acquisition spectrum from program initiation to production-deployment, certain event and situation simulation will be necessary. The contractor will include a test

scenario and the performance evaluation standards necessary to test each module and the C³APMIS as a complete system in the Demonstration and Evaluation Plan required by the Statement of Work..

8.4 Test Reports. Each of the C³APMIS modules will require a test report as well as a final System Demonstration and Evaluation Report. The test reports will consist of data collection and analysis necessary to measure predictive performance standards and test objectives against actual results and any differences will be explained.

8.5 Test Support. HQMC, Code CCT will monitor the demonstration and evaluation testing and approve test reports.

SECTION 9. CONTRACTOR SUPPORT

9.1 Contractor Support Requirements. Contractor tasks/support requirements which have been identified throughout the SP are listed below. The number in parenthesis following each statement identifies the SP reference paragraph.

- a. Utilize available USMC equipment. (3.1)
- b. Provide certain equipment to implement the prototype C³APMIS. (3.1)
- c. Comply with siting factors for contractor provided equipment. (3.2)
- d. Maintain contractor provided equipment. (3.3.1)
- e. Support contractor provided equipment. (3.3.2)
- f. Provide packaging, storage, and transportation requirements for contractor provided equipment. (3.3.3)
- g. Be responsible for configuration control of contractor provided equipment. (3.3.5)
- h. Utilize specifically identified software packages. (4.1)
- i. Operate the prototype C³APMIS. (5.2)
- j. Determine data transfer requirements. (6.1)

- k. Network prototype C³AMIS system components within HQMC, Code CCT, office spaces. (6.2)
- l. Identify communications connectivity needed between the HQMC, Code CCT network and the MCCDPA main frame computer at Quantico, Va. and the CCT network and Annandale, Va. (6.2.2.1)
- m. Operate communications equipment/services required for the prototype C³APMIS. (6.2.2)
- n. Prepare the Management Plan. (7.1)
- o. Conduct prototype C³APMIS Demonstration and Evaluation (8.1 and 8.3)
- p. Prepare test scenario (8.3)
- q. Prepare Development and Evaluation Plan (8.3)
- r. Prepare test reports (8.4)

COST ESTIMATE

TABLE OF CONTENTS

<u>Section</u>	<u>Page</u>
1.0 INTRODUCTION	1-1
1.1 Organization	1-1
1.2 Assumptions	1-1
2.0 COST ESTIMATE	2-1
2.1 General	2-1

LIST OF FIGURES

<u>Title</u>	<u>Page</u>
1.1 Prototype System Network	1-2

LIST OF TABLES

<u>Title</u>	<u>Page</u>
2.1 Acquisition and Operating Costs	2-2
2.2 Estimated Hardware, Software and Support Costs for C ³ APMIS . . .	2-3

C³ Automated Planning and Management Information
Preliminary Cost Estimate

SECTION 1. INTRODUCTION

1.1 Organization. The C³Automated Planning and Management Information System (C³APMIS) prototype will consist of a microcomputer LAN located within the office space of HQMC, Code CCT with connection to existing Marine Corps main frame computers to provide access to Class I Automated Information Systems (AIS) data bases as depicted in Figure 1.1. This network will provide system subscribers the ability to share files and exchange information.

The prototype system will provide automated management assistance for the acquisition of C⁴ systems and demonstrate the acquisition management process. This management process will consist of two main modules (Requirements and Acquisition Management), and two sub modules (PPBS and Requirements Allocation). These modules provide acquisition management support from the program initiation phase through the production-deployment phase in the areas of requirement identification, planning, and project management.

The prototype system requires connection to data bases located at MCCDPA, Quantico. Major Marine Corps automated data processing equipment and software is IBM compatible and uses IBM compatible operating system software. Major sites in the MCDN network operate with Marine Corps controlled standard software.

1.2 Assumptions. The following assumptions have been utilized in determining costs shown in Table 2.1 and Table 2.2.

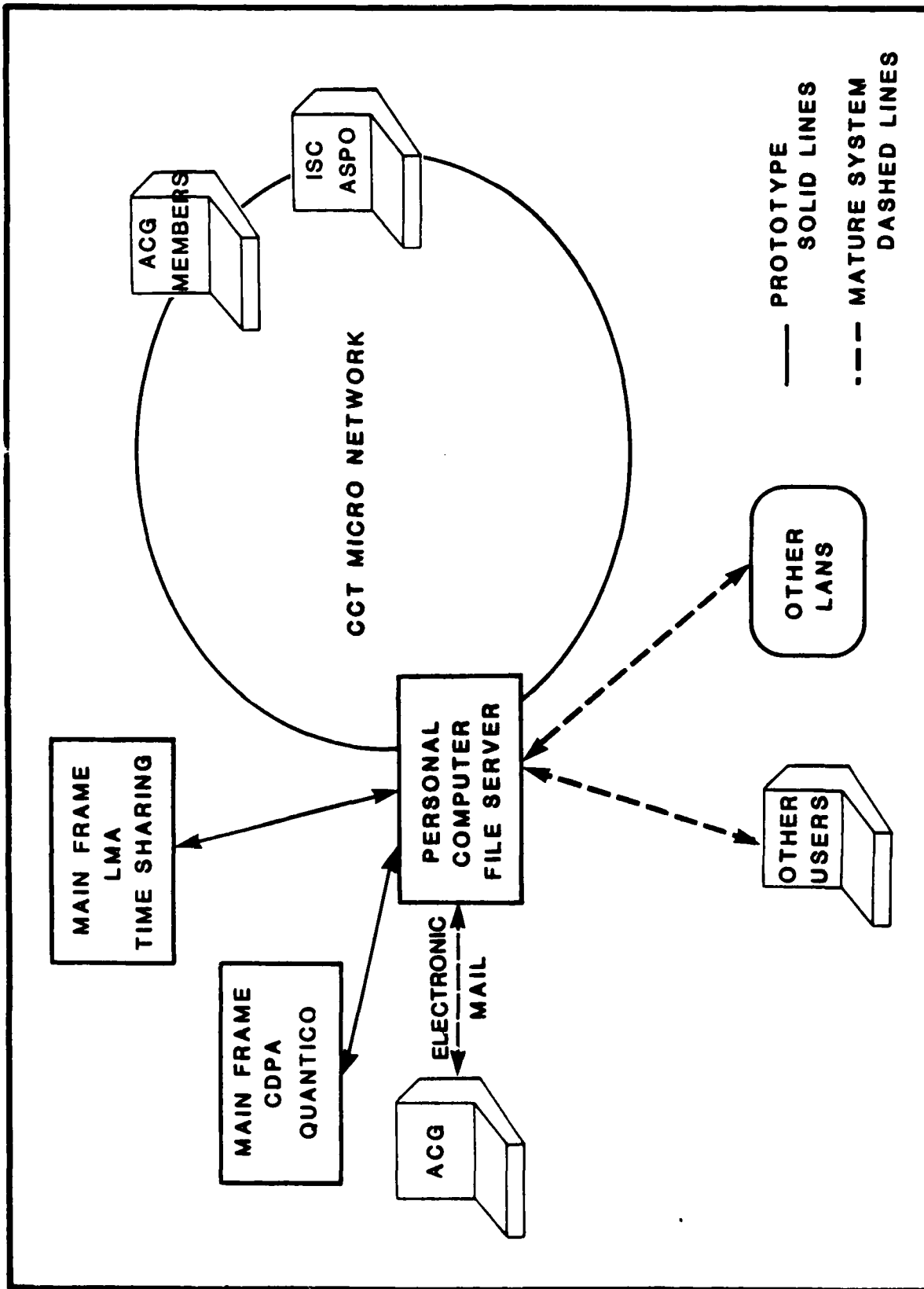

Figure 1.1. Prototype System Network

1. Selected Marine Corps hardware, software and telecommunications assets will be used in the prototype system. These assets are listed in the C³APMIS Statement of Work dated 6 September 1985.
2. The current contractual effort providing HQMC, Code LMA access to the Integrated Management Planning Cost Tracking (IMPACT) model will continue.
3. Data bases and data dictionaries created by the Integration Support Contractor (ISC) will be developed in accordance with DATAMANAGER, the Marine Corps standard.
4. No classified information will be processed on the prototype C³APMIS.
5. Hardware procured for the prototype C³APMIS will be capable of installation in HQMC, Code CCT workspaces on either commonly available tables/desks or specially designed stands provide by the ISC.
6. The ISC will procure equipment and software to complete the LAN installation and will have access to the GSA schedule for purchases.
7. Hardware shall operate on standard 60 Hz, 110/120 VAC power.
8. Maintenance of equipment and replacement/spare parts provide by the ISC shall be the responsibility of the ISC.
9. The prototype C³APMIS will be developed, demonstrated and implemented during FY86. Cost estimates are in current year dollars.

10. HQMC, Code CCT IBM PC-XT microcomputers will be used for the LAN.

11. Telecommunications will be furnished by the government. If unavailable, ISC will furnish.

SECTION 2. COST ESTIMATE

2.1 General. The cost estimate has been developed from tasks identified in the C³APMIS Statement of Work to assist the government in evaluating bids submitted in response to the anticipated solicitation. The prototype C³APMIS will be developed demonstrated and implemented by the ISC. Contractor personnel, equipment and specific GFE will be utilized to validate the C³APMIS concept. Acquisition and Operating Costs are summarized in Table 2.1. Estimate Hardware, Software and Support Costs are itemized in Table 2.2

TABLE 2.1 Acquisition and Operating Costs

PRODUCTION

Procurement Estimates

Hardware	5,050
Installation	9,962
Software Services	<u>213,967</u>

Total Estimated Procurement Costs	228,979
-----------------------------------	---------

Operating and Support

O&M	0
MILPERS	0
Total O&S	<u>0</u>

TOTAL LIFE-CYCLE REQUIREMENTS	228,979
-------------------------------	---------

Table 2.2 Estimated Hardware, Software and Support Costs for a C 3 Automated Planning and Management Information System

ITEM	QUANTITY	NON-RECURRING			RECURRING				
		PROCUREMENT COST		INSTALLATION		LEASE	MAINT	TOTAL COST PER MONTH	TOTAL COST PER YEAR
		EACH	TOTAL	EACH	TOTAL				
TASK 1									
INSTALL, TEST AND EVALUATE LAN	160 MH			9,962	9,962				
EQUIPMENT									
IBM PCXT	2	GFE	0						
LTR QUALITY PRINTER	1	GFE	0						
PC FILE SERVER	1	3,500	3,500						
MODEM	1	700	700						
COMMUNICATION WIRE	100 FT		250						
COMMUNICATION BOARDS	2	300	600						
SOFTWARE									
COMMUNICATIONS		GFE	0						
SYSTEM SOFTWARE		GFE	0						
TELEPHONE LINES		GFE	0						
TASK 2									
DEVELOP DETAILED PHYSICAL SYSTEM DESIGN									
2.1 REQUIREMENTS									
MODULE (DESIGN ONLY)									
REQUIREMENTS									
DOCUMENT FILE	160 MH		7,962						
STO FILE	160 MH		7,962						
MAA FILE	160 MH		7,962						
MISCELLANEOUS DEF FILE	160 MH		7,962						
OTHER SERVICE FILE	160 MH		7,962						
PAGE TOTALS	960 MH		44,860		9,962				

Table 2.2 Estimated Hardware, Software and Support Costs for a C 3 Automated Planning and Management Information System

ITEM	QUANTITY	NON-RECURRING			RECURRING			
		PROCUREMENT COST	INSTALLATION		MAINT	LEASE	COSTS	
			EACH	TOTAL			EACH	MONTH
- CROSS REFERENCE FILE	160 MH							
- TECHNOLOGY FILE	160 MH	7,962						
2.2 DEVELOP ACQUISITION MANAGEMENT FILE		7,962						
MASTER EVENT FILE		0						
MASTER DOCUMENT FILE		0						
MASTER ORGANIZATIONAL FILE	320 MH	15,923						
MASTER PROJECT FILE	320 MH	15,923						
2.2 DEVELOP PPBS SUB-MODULE								
PMC POM								
INITIATIVE FILE	320 MH	15,923						
FYDP FILE	320 MH	15,923						
BUDGET EXECUTION FILE	320 MH	15,923						
BUDGET HISTORY FILE	320 MH	15,923						
C4PROJECT PRIORITY FILE	320 MH	15,923						
TASK 3 DEVELOP AND TEST SCREEN FORMATS AND REPORT FORMATS	CONCURRENT FUNDED AS PART OF TASK 2							
TASK 4 DEVELOP MANAGEMENT PLAN	80 MH	4,439						
TASK 5 DEMONSTRATION AND EVALUATION PLAN	80 MH	4,439						
PAGE TOTALS	2,720 MH	136,263						

Table 2.2 Estimated Hardware, Software and Support Costs for a C 3 Automated Planning and Management Information System

ITEM	QUANTITY	NON-RECURRING			RECURRING				
		PROCUREMENT COST		INSTALLATION		MAINT	LEASE	COSTS	
		EACH	TOTAL	EACH	TOTAL	TOTAL COST PER YEAR	COST PER MONTH EACH	TOTAL COST PER MONTH	TOTAL COST PER YEAR
5.1 TEST REPORT	80 MH		4,439						
5.2 TEST SCENARIO	40 MH		2,220						
TASK 6 DEVELOP A DETAILED DESIGN SPECIFICATION FOR MATURE SYSTEM	320 MH		15,923						
TASK 7 DEVELOP SYSTEM OPERATIONAL PROCEDURES	160 MH		7,656						
TASK 8 COST ESTIMATE	160 MH		7,656						
PAGE TOTALS	760 MH		37,894						
TOTALS	4,440 MH		219,017						9,962

UNCLASSIFIED

PROTOTYPE SYSTEM SPECIFICATION

TABLE OF CONTENTS

Section	Page
1.0 Introduction	1-1
1.1 Background	1-1
1.2 Purpose	1-3
1.3 Scope	1-3
2.0 Baseline Functional Specification	2-1
2.1 Methodology	2-1
2.2 General System Specification	2-2
2.2.1 Requirements Module	2-2
2.2.1.1 Requirements Documents File	2-5
2.2.1.2 Science and Technology Objectives (STO) File	2-6
2.2.1.3 Mission Area Analysis File	2-6
2.2.1.4 Miscellaneous Deficiencies File	2-7
2.2.1.5 Other Service Requirements File	2-8
2.2.1.6 Cross Reference File	2-8
2.2.1.7 Technology Reference File	2-9
2.2.2 Acquisition Management Module	2-10
2.2.2.1 Master Event List File	2-12
2.2.2.2 Master Document List File	2-13
2.2.2.3 Master Organization List File	2-13
2.2.2.4 Project Event File	2-13
2.2.2.5 Project Document File	2-14
2.2.2.6 Contract Events File	2-14
2.2.2.7 Project Organizations File	2-14
2.2.2.8 Build Schedule	2-15
2.2.2.9 Master Project File	2-15
2.2.3 PPBS Sub Module	2-16
2.2.3.1 PMC POM Initiative Data File	2-16
2.2.3.2 FYDP File	2-18
2.2.3.3 Budget Execution File	2-19
2.2.3.4 Budget History File	2-19
2.2.3.5 C ⁴ Project Priority File	2-20
2.2.4 Resource Allocation Sub Module	2-20
2.2.4.1 Logistics Management Information System (LMIS) Access File	2-22
2.2.4.2 Table of Manpower Requirements (TMR) Access File	2-22
2.2.4.3 FYDP File	2-22
2.2.4.4 Interoperability File	2-23
3.0 System Design Specification	3-1
3.1 Hardware/Software Requirements	3-1
3.1.1 Hardware Requirements	3-1
3.1.2 Software Requirements	3-2
3.1.3 Software Availability	3-3
3.2 Network Design	3-4

3.3	Network Components	3-7
3.3.1	File Facility	3-7
3.3.2	Workstations	3-7
3.3.2.1	Display	3-8
3.3.2.2	Keyboard	3-8
3.3.2.3	Computer	3-8
3.3.2.4	Disk Storage	3-8
3.3.2.5	Printers	3-9
3.3.2.6	Operating System	3-9
3.3.3	Communications to Main Frame Computers	3-9
3.3.3.1	Asynchronous Interactive Terminal Emulation	3-10
3.3.3.2	RJE Terminal Emulation Using Bisynchronous Protocols	3-10
3.3.3.3	3270 Terminal Emulation	3-11
3.4	Application Software	3-12
3.4.1	Word Processing	3-12
3.4.2	Electronic Spread Sheet	3-15
3.4.3	Graphics/Report Generation	3-15
3.4.4	Calendar Management	3-16
3.4.5	Data Base Management	3-16
3.4.6	Project Management	3-17
3.4.7	Electronic Mail	3-17

List of Figures

	Title	Page
2.1	Acquisition Planning and Mangement System Information Flow	2-3
2.2	Requirements Module Data Flow Diagram	2-4
2.3	Acquisition Management Module Data Flow Diagram	2-11
2.4	PPBS Sub Module Data Flow Diagram	2-17
2.5	Resource Allocation Sub Module Data Flow Diagram	2-21
3.1	Prototype System Network	3-5

Appendix

Appendix A	File Description	A-1
Appendix B	Information Sources and Data Elements	B-1

C³ AUTOMATED PLANNING AND MANAGEMENT INFORMATION SYSTEM
PROTOTYPE SYSTEM SPECIFICATION

1.0 Introduction

1.1 Background

The Director, Command, Control, Communications and Computer (C⁴) Systems Division (DirC⁴SysDiv) provides for the planning, directing and coordinating of staff activities on matters relating to command and control systems, telecommunications and automated information systems. Acting in this capacity, the DirC⁴SysDiv is designated as the Acquisition Program Sponsor (APS) for the acquisition of Marine Corps C⁴ systems and equipment.

To assist in carrying out acquisition responsibilities the APS designates an Acquisition Sponsor Project Officer (ASPO) for each acquisition project. The ASPO, acting as the project advocate, chairs the Acquisition Coordinating Group (ACG). This group is composed of Headquarters Marine Corps (HQMC) and Marine Corps Development and Education Command (MCDEC) representatives. The collection, analysis and exchange of information between members of the ACG is critical to decisions affecting project planning, scheduling, monitoring, and controlling of C⁴ projects.

Marine Corps Order (MCO) P5000.10A, Systems Acquisition Management Manual, and MCO P5231.1, Life Cycle Management for Automated Information Systems,

prescribe a structured process to manage the acquisition of new systems. Each acquisition project is subject to a series of reviews and decisions at specified milestones during the acquisition cycle. Each review/decision is dependent on successful completion of specific requirements and must be supported with comprehensive and detailed project documentation.

Resources required to implement an acquisition project must be included in the Five Year Defense Program (FYDP) which is produced during the DOD Planning, Programming and Budgeting System (PPBS) process. The ASPO plays a significant role in programming and monitoring required resources and must have access to FYDP data.

Each ACG member is responsible for maintenance of project documentation from his functional area that pertains to the acquisition project. ACG members are dependent on the activities and data supplied by other ACG members. Information is exchanged among ACG members by personal contact, written memoranda/reports, or telephonic means.

Presently, ACG members use a combination of manual status tracking and individually developed automation aids to satisfy information processing requirements. Although ACG members have a limited amount of automated equipment to assist them in acquisition management tasks, procurement of this equipment has been made on a piecemeal basis by individual staff agencies, and there is virtually no automated capability to exchange data between staffs.

1.2 Purpose

This document specifies the prototype system requirements necessary to design and implement a Prototype C³ Automated Planning and Management Information System and provides the detailed hardware and software system design guidance required to produce an operational prototype system.

1.3 Scope

The Prototype System Specification is divided into two sections.

- o Section 1, Baseline Functional Specification (BFS). The purpose of this specification is to translate identified user requirements into logical groupings of activities and data. The BFS graphically displays the logical processes and the data files required for the C³ Automated Planning and Management Information System. This structured systems analysis approach constitutes the basis for the more detailed System Design Specification and specifies the

developmental constraints and system requirements which must be satisfied during all subsequent system development efforts. The BFS is written as a statement of requirements and constraints to guide the Integration Support Contractor (ISC) in developing the Prototype C³ Automated Planning and Management Information System

- o Section 2, System Design Specification. The purpose of this specification is to describe the detailed hardware and software specifications necessary to implement the structured functional design requirements contained in Section 1. These detailed specifications provide specific guidance for the Prototype C³ Automated Planning and Management Information System, which will consist of a Local Area Network (LAN) of microcomputers connected to the Marine Corps main frame computer located at Marine Corps Central Design and Programming Activity (MCCDPA), Quantico, Va. and commercial time sharing computer systems currently in use.

The aggregate of these specifications will provide a road map for the acquisition of equipment or software, and a logical system framework within which the ISC will complete the physical design and implementation of the prototype system.

2.0 Baseline Functional Specification

2.1 Methodology

The C³ Automated Planning and Management Information System is designed to assist the APS and his designated representative, the ASPO, in those efforts necessary to organize and implement program requirements, accumulate cost and schedule data, evaluate and report status, identify cost and schedule variance, perform "what if" analyses, and integrate changes while maintaining the required traceability to the original project baseline.

To satisfy these system requirements, activities performed or required by the APS were identified. These activities were then mapped against the logical processes required to accomplish these activities, and the data flow and logical data bases necessary to support these processes were defined. This analysis was used to construct data flow diagrams which showed the sources and destination of data, boundaries of the system, and identified logical processes to be performed. The product of this top down design is an understandable graphic and narrative description of the C³ Automated Planning and Management Information System to guide the ISC in implementing the physical design of the system.

2.2 General System Description

The acquisition methodology utilized by the APS and the ASPO can be described as a management process, as shown in Figure 2.1, consisting of two main modules (Requirements and Acquisition Management), and two sub modules (PPBS and Resource Allocation). These modules provide acquisition management support from the program initiation phase through the production deployment phase of the acquisition cycle in the areas of requirement identification, planning, and project management. Each of the modules/submodules consist of a group of functionally related data files. Appendix A, File Description, provides an example of how a file would be constructed, showing the data elements contained in the file, a typical screen display/report format and standard screen menu.

Sources of information to construct data files have been identified as a result of a review of Marine Corps acquisition documentation and interviews with members of the ACG and other personnel involved in the C⁴ system acquisition process. Appendix B contains a listing of the information sources and data elements identified.

2.2.1 Requirements Module. The Requirements Module (Figure 2.2) provides for the collection and review of supporting data to justify program new starts. In coordination with the CG, MCDEC, this module will assist the APS in identifying new operational requirements or deficiencies. The processes of review and evaluation of requirements, new technology and deficiencies are

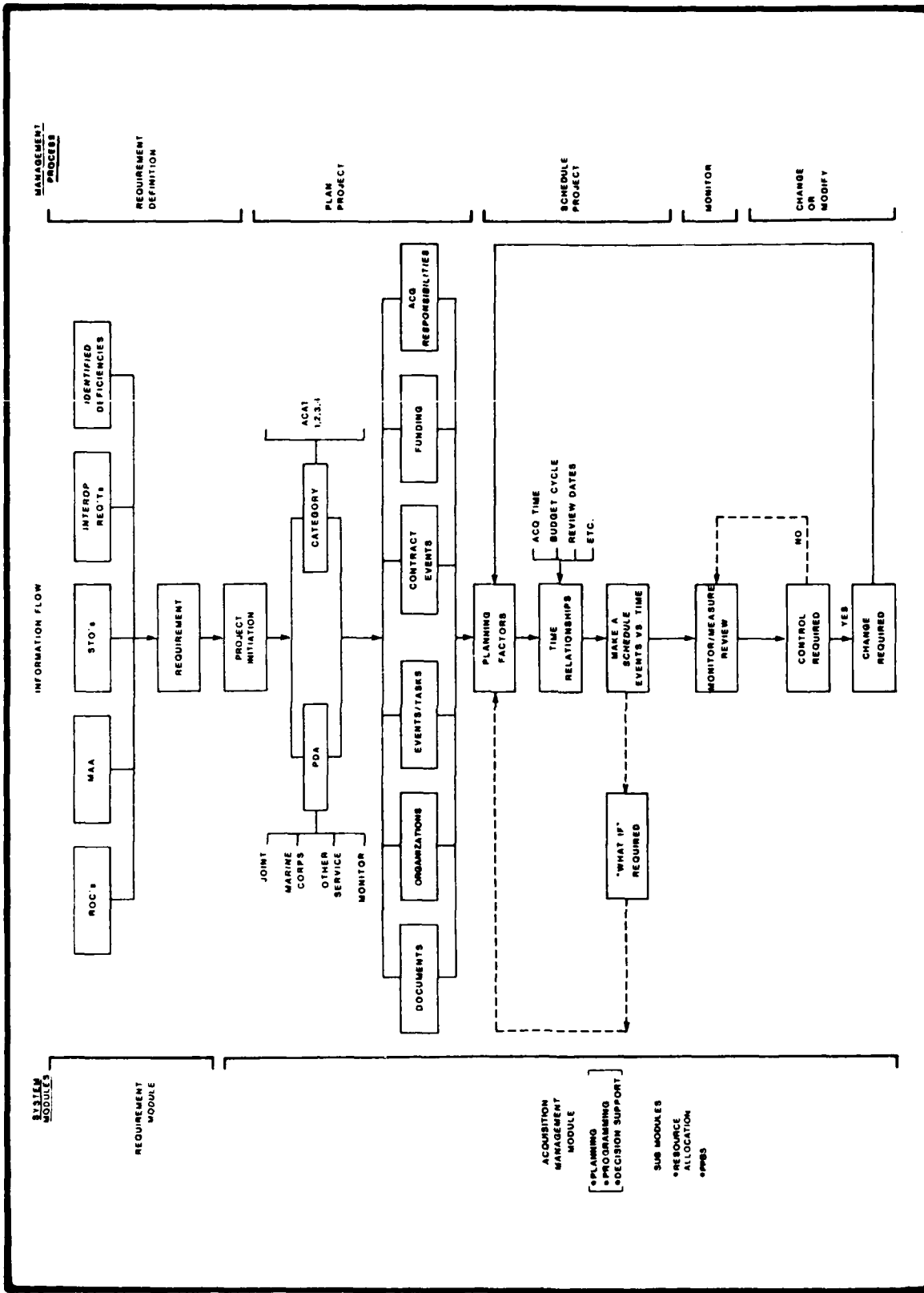

Figure 2.1. Acquisition Planning & Management System Information Flow

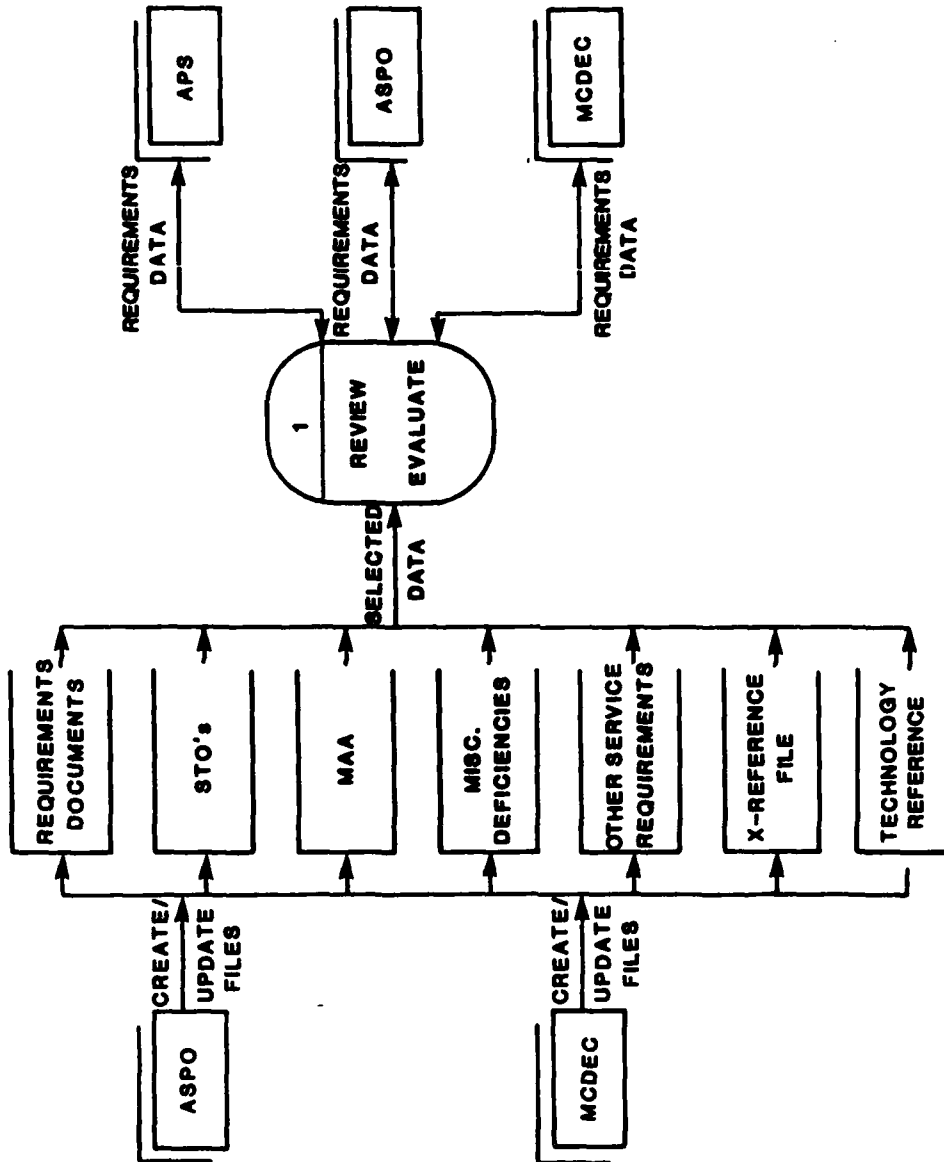

Figure 2.2. Requirements Module Data Flow Diagram

the primary functions of this module. This data base is similar to the McKees system used at one time by the Development Center at MCDEC. There are seven files that comprise this module.

2.2.1.1 Requirements Documents File. This file will contain data pertaining to program initiation and operational requirements documents as follows:

- o Listing of Justification for Major System New Starts (JMSNS)/ Justification for System New Starts (JSNS) by Science and Technology Objective (STO) and mission areas in the STO and MAA Files
 - oo For JSNS, include narrative description of the requirement and capabilities
 - oo For JMSNS, include narrative description of the mission and threat
- o Listing of Required Operational Capability Documents (ROCs) and Draft ROCs by STO and mission areas in the STO and MAA Files. The following data will be included:
 - oo Narrative descriptions of the requirement and operational deficiency

- oo Most recently achieved acquisition cycle milestone and date achieved
- oo Responsible office at HQMC

2.2.1.2 Science and Technology Objectives (STO) File. This file is closely related to and built upon the MAA File and will contain the following information for each STO related to the mission areas contained in the MAA file:

- o USMC objectives for the mid-long range (10-20 years) period
- o Technology base program guidance
- o FMF unique operational requirements
- o Common user system desired characteristics
- o Basis for Product Improvement Programs

The STO file will have the following characteristics:

- o Afford read access to all USMC system users
- o Restrict write access to the DPO
- o Interface with word processing, electronic mail, and report generation system functions

2.2.1.3 Mission Area Analysis File. This file will contain the following data:

- o An index of appropriate mission areas, with narrative description of each
- o The decision tree for each mission area contained in the file
- o A listing of deficiencies keyed to the decision tree, to include a narrative description, the source of the deficiency, and recommendations for resolution for the deficiency

The MAA File will have the following characteristics:

- o Afford read access to all USMC system users
- o Restrict write access to the ASPO and DPO
- o Interface with word processing and electronic mail system functions

2.2.1.4 Miscellaneous Deficiencies File. This file will contain requirements/ deficiencies identified by other sources which cannot be appropriately entered into the other Requirements Module files. For example, this file can be utilized by any system user to catalog deficiencies identified through such activities as exercises or evaluations, test programs, logistics reports, or field visits. The file will be established as an unstructured narrative file which can meet the particular needs of any system user.

2.2.1.5 Other Service Requirements File. This file will contain the following data:

- o Listing of all other service documents with C⁴ implications forwarded to MCDEC for review/comment
- o The STO/mission area, if appropriate, which applies to each other service requirement
- o Narrative description of requirement or operational deficiency from each other service document
- o USMC position on harmonization for each other service requirement

The Other Service File will have the following characteristics

- o Afford read access to all system users
- o Restrict write access to MCDEC
- o Interface with word processing and electronic mail system functions

2.2.1.6 Cross Reference File. This file will contain relationships between requirements documents, and provide a capability to accomplish the following:

- o Sort and query documents by requirement deficiency, STO or Mission Area
- o Identify common requirement developed from requested capabilities and identified deficiencies

- o Establish audit trail between stated requirement/deficiency and corrective action or project improvement

2.2.1.7 Technology Reference File. This file will contain bibliographic reference to current articles and studies pertaining to various command, control, communications and computer technologies which are deemed critical by the C⁴ SysDiv and will contain the following data:

- o Listing of current articles or information by title and author.
- o Narrative description of article content by subject.

The Technology Reference File will have the following characteristics:

- o Afford read access to all system users.
- o Afford users the ability to add additional reference citations.
- o Interface with word processing and electronic mail system functions.

2.2.2 Acquisition Management Module. Two major acquisition processes are accomplished by the Acquisition Management Module, (Figure 2.3) planning and scheduling.

- o Planning - Dependent upon the selection of the Principal Development Activity (PDA) and project Acquisition Category (ACAT), the Acquisition Management Module defines the tasks to be accomplished and how the work will be organized, which includes assignment of organizational responsibilities, project events to be tracked, and documentation needed

- o Scheduling - After the project events, have been identified, time lines are then applied against events identified . The Acquisition Management Module assists the user in constructing a time-phased dependency network schedule, which provides a "what if" capability, and the capability to monitor the progress of the project, i.e., planned versus actual. The Acquisition Management Module will integrate key project events from all functional and supporting areas, generate project management alternatives, evaluate impacts of management actions, and utilize decision support methodologies to assist ACG members and the APS to exercise control of the acquisition project

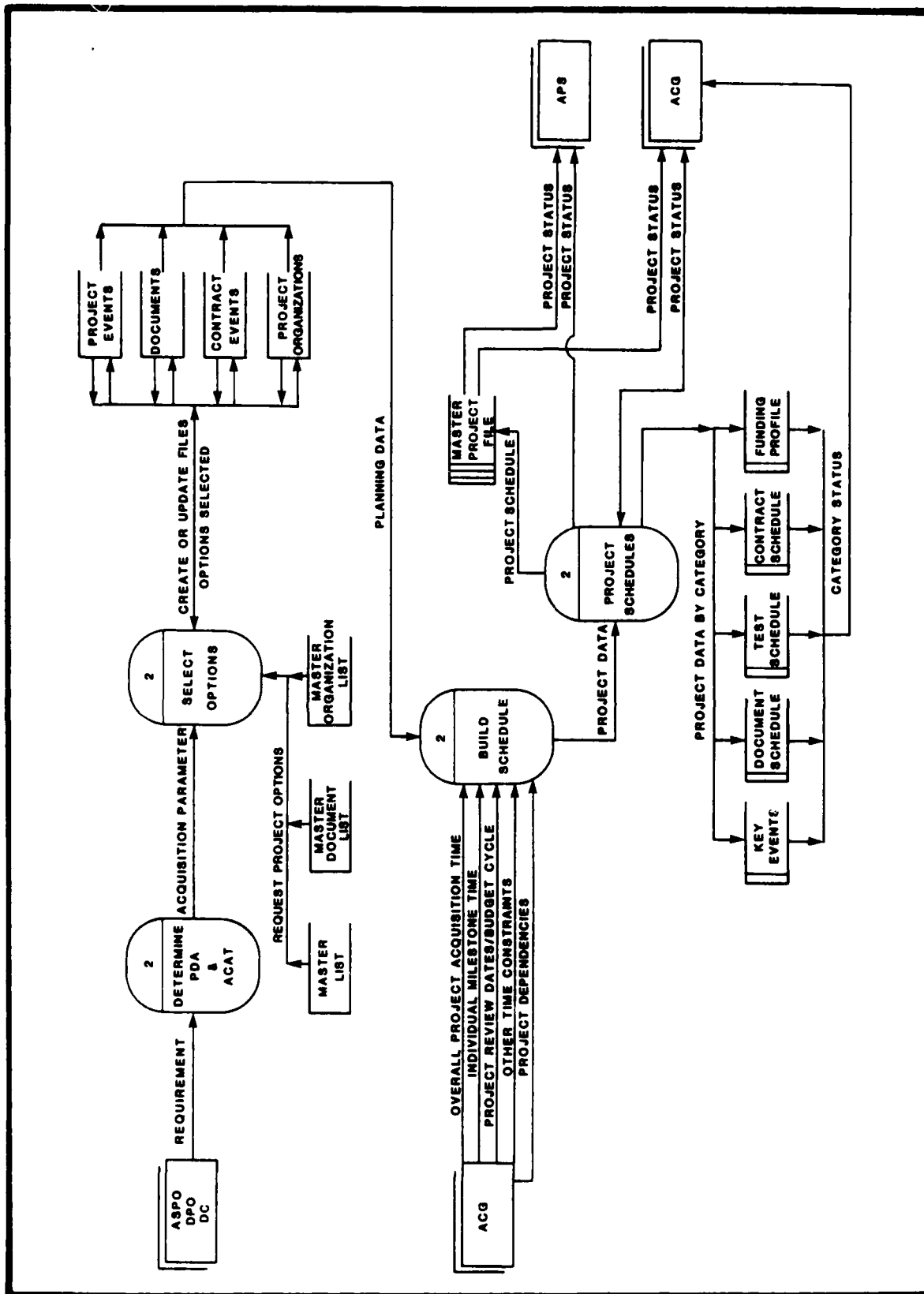

Figure 2.3. Acquisition Management Module Data Flow Diagram

This module is constructed using a series of three master data base lists from which unique project files are created based upon the selection of control parameters. The control parameters are the Principal Development Activity (PDA) and the Acquisition Category (ACAT) of the project. Each data element contained in the master data lists will be coded with the appropriate control parameters or combinations of control parameters.

Unique project files will be created from the master data base files. The ASPO will call up project master data base listings of events, documents and organizations on a menu driven format and select or discard planning factors to be used in the project acquisition process. This capability allows the system user to add or delete entries and build project files. There are four distinct project files. The discrete project files are the Project Event File, Project Document File, Contract Event File and the Project Organization File.

2.2.2.1 Master Event List File. This file is a comprehensive listing of all possible events that could pertain to any given acquisition project. This data base has been constructed under a previous Marine Corps contract and is currently being utilized by HQMC Code LMA. This data base will be utilized as the Master Event List. Appropriate procedures will be developed in conjunction with LMA for input and output of data to satisfy the C³ Automated Planning and Management Information System user requirements.

2.2.2.2 Master Document List File. This file will contain a listing of all documentation, organized by acquisition cycle milestone, that could pertain to any given acquisition project. This file will have the following characteristics:

- o Afford read access to all system users
- o Restrict write access to HQMC/CCT

2.2.2.3 Master Organization List File. This file will contain a listing of all organizations which could have responsibilities for any given acquisition project. Each organizational entry shall contain an office symbol, mailing address and, if appropriate, a point-of-contact telephone number. This file will have the following characteristics:

- o Afford read access to all system users
- o Restrict write access to HQMC/CCT

2.2.2.4 Project Event File. This file will contain a listing of all events which apply to the acquisition project and will have the following characteristics:

- o Afford read access to all ACG members
- o Restrict write access to the ASPO

2.2.2.5 Project Documents File. This file will contain a listing of all documentation which applies to a given acquisition project. As appropriate, each document shall be referenced to an event from the Project Event File, due-date, and the responsible office. The Project Documents File will have the following characteristics:

- o Afford read access to all ACG members
- o Restrict write access to the ASPO

2.2.2.6 Contract Events File. This file will be an extraction of all events from the Project Event File which pertain to the contracting process for project contracts. The Contract Events File will identify all contracting events required to obtain contracts through each phase of the acquisition cycle from R&D through production. This file shall have the following characteristics:

- o Afford read access to all ACG members and HQMC/CCP
- o Restrict write access, by data element, to any single user or conceivable combination of users
- o Interface with word processing, spread sheet, report generation, and electronic mail system functions

2.2.2.7 Project Organizations File. This file will contain a listing of all organizations with responsibilities for the acquisition project. This file

shall have the following characteristics:

- o Afford read access to all ACG members
- o Restrict write access to the ASPO

2.2.2.8 Build Schedule. After the program events, milestones, etc., have been selected, time lines derived from individual milestone times, project review dates/budget cycle and other time constraints are applied against planning data identified during option selection. This scheduling capability assists the user in constructing a time-phased dependency network schedule, and provides a "what if" capability as needed. It also provides the capability to monitor the progress of the project, i.e., planned versus actual. This includes the measurement of schedule, documentation, contractor performance, and funds. With the benefit of this information, reviews are held at different management levels to determine if program control is needed or changes are required to be made.

2.2.2.9 Master Project File. This file will contain Project Event File data from all C⁴ acquisition projects and have the capability of determining inter-project dependencies and assessing the impact of changes within one project upon all other projects. This file will also have the capability to produce reports or schedules across all or selected C⁴ projects tailored to a specific function, event, or group of events. For example, testing schedules, design reviews, or documentation schedules for either all or a selected number of projects could be produced for analysis or review. The Master Project File will have a menu-driven index which allows any system user to select any grouping of projects or events for presentation. As updates to

individual Project Event Files are accomplished, the Master Project File will be automatically updated. The Master Project File will have the following characteristics:

- o Afford reread access to all ACG members
- o Restrict write access to the ASPO

2.2.3 PPBS Sub Module. The PPBS Sub Module (Figure 2.4) is designed to satisfy the requirements of the APS, ASPO, and other ACG members for PPBS related data, primarily current baseline resource requirement profiles and information needed to justify project requirements during the POM development process. Resource information is obtained from many different sources encompassing virtually all functional staff areas, but it is the ASPO and APS, as the program sponsor, who must insure resource requirements are entered into the FYDP to satisfy project requirements in a timely and adequate manner.

2.2.3.1 PMC POM Initiative Data File. The ASPO must develop the Procurement Marine Corps (PMC) Program Objective Memorandum (POM) Initiative document. This document contains programmatic and resource requirements data and other information utilized by the POM Working Group to prioritize the project in the USMC POM. All of the data contained in the PMC POM Initiative document shall be entered into the PMC POM Initiative File. This file will have the following characteristics:

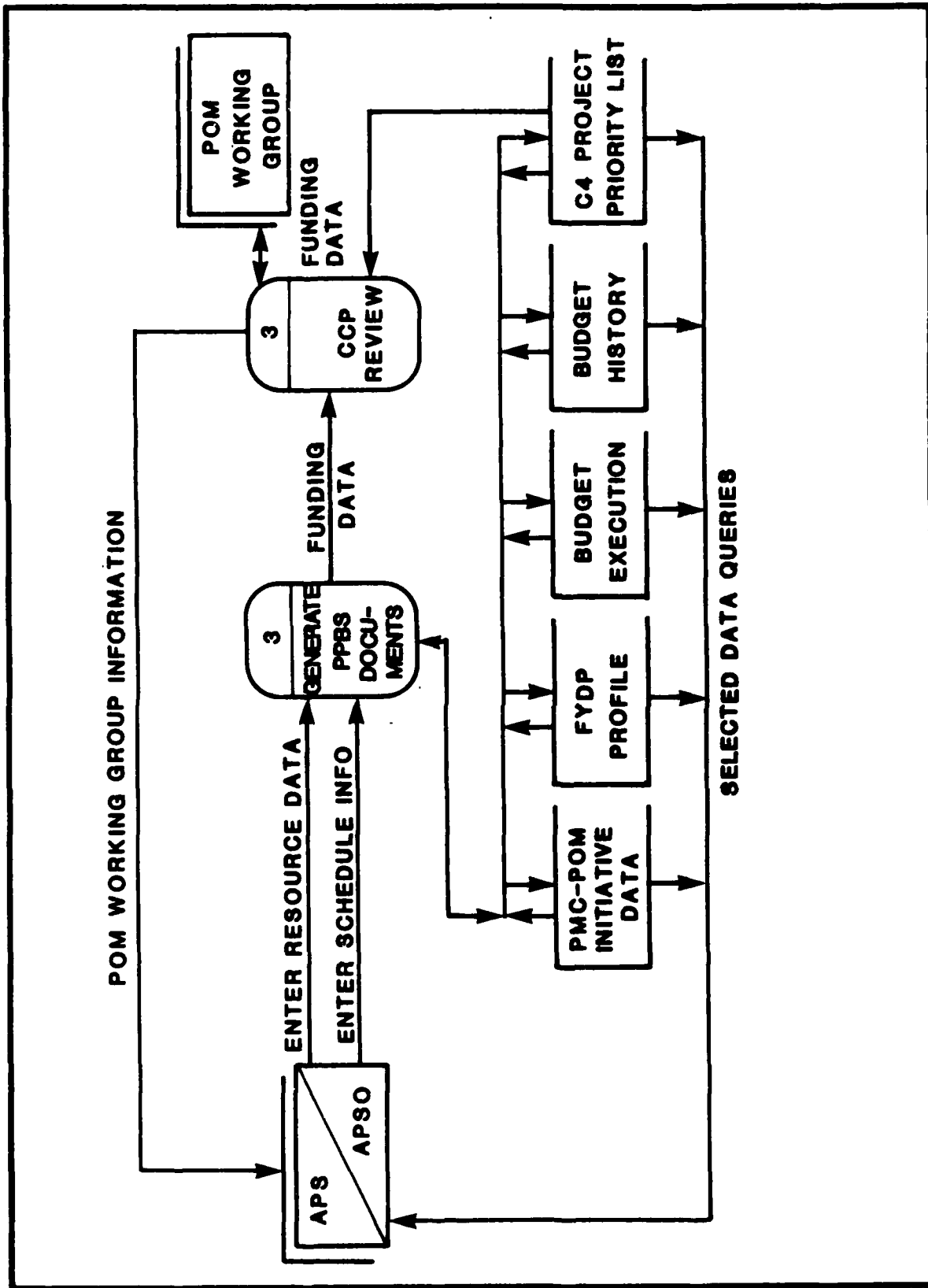

Figure 2.4. PPBS Sub Module Data Flow Diagram

- o Accommodate entry of discrete data elements, such as dates, costs, equipment quantities, etc., as well as narrative descriptions
- o Afford read access to all ACG members and HQMC, Code CCP
- o Restrict write access, by data element or narrative entry, to any single user or conceivable combination of users
- o Interface with report generation, word processing, spread sheet, and electronic mail system functions

2.2.3.2 FYDP File. All data related to program cost and manpower requirements in the file created for the PMC POM Initiative must be capable of being extracted into a second distinct file identified as the FYDP File. The FYDP File will contain all FYDP updates until the project reaches completion. The FYDP File will have the following characteristics:

- o Accommodate entry of cost, manpower, and equipment quantity information for FYDP years, by appropriation and by program element, for each FYDP update
- o Identify differences between any combination of eight consecutive FYDP updates for any data element, and accommodate a narrative explanation of that difference
- o Afford read access for any FYDP update to all ACG members and HQMC, Code CCP
- o Interface with report generation, word processing, spread sheet, and electronic mail system functions

2.2.3.3 Budget Execution File. This file will store data depicting initiation, commitment, and obligation status of funds in each appropriation over the life of the project. Data files will be established consistent with cost detail information contained in the FYDP.

The Budget Execution File will have the following characteristics:

- o Accommodate entry of discrete data elements, such as costs and dates, as well as narrative information
- o Compare baseline dollar totals with each status entry of initiated, committed, and obligated funds and calculate resultant percentage
- o Afford read access to all ACG members and HQMC, Code CCP
- o Interface with report generation, word processing, spread sheet, and electronic mail functions

2.2.3.4 Budget History File. This file will be an unstructured narrative file which is capable of maintaining documentation pertaining to special point papers prepared to justify budget submission or execution requests, budget issue papers, congressional budget marks, and reclaims. The Budget History File will have the following characteristics:

- o Provide an indexing scheme of information contained within the file
- o Afford read access to all ACG members and HQMC, Code CCP
- o Restrict write access to the ASPO

2.2.3.5 C4 Project Priority File. This file will be constructed as follows:

- o Cover the FYDP years
- o Contain a listing of all C⁴ projects, and for each project list the total obligation authority and funding totals by appropriation
- o Provide an indication of the current approved budget level which shows which projects are included in the FYDP

The C⁴ Project Priority File will have the following characteristics:

- o Afford read access only to C⁴ Systems Division users
- o Restrict write access to HQMC, Code CCP
- o Interface with report generation, spread sheet, word processing, and electronic mail system functions

2.2.4 Resource Allocation Sub Module. The purpose of the Resource Allocation Sub Module (Figure 2.5) is to allow system users to conduct "what if" analyses concerning the allocation of project resources. "What if" analysis allows system users to choose among alternatives in allocation of resources and to assess the impacts of changes in resource levels, e.g., changes in funding or schedule. Several individual files within this sub module will contain program resource data. Utilization of these files in conjunction with system functions, for example spread sheet, will allow system users to manipulate resource data without destroying the integrity of the baseline data base.

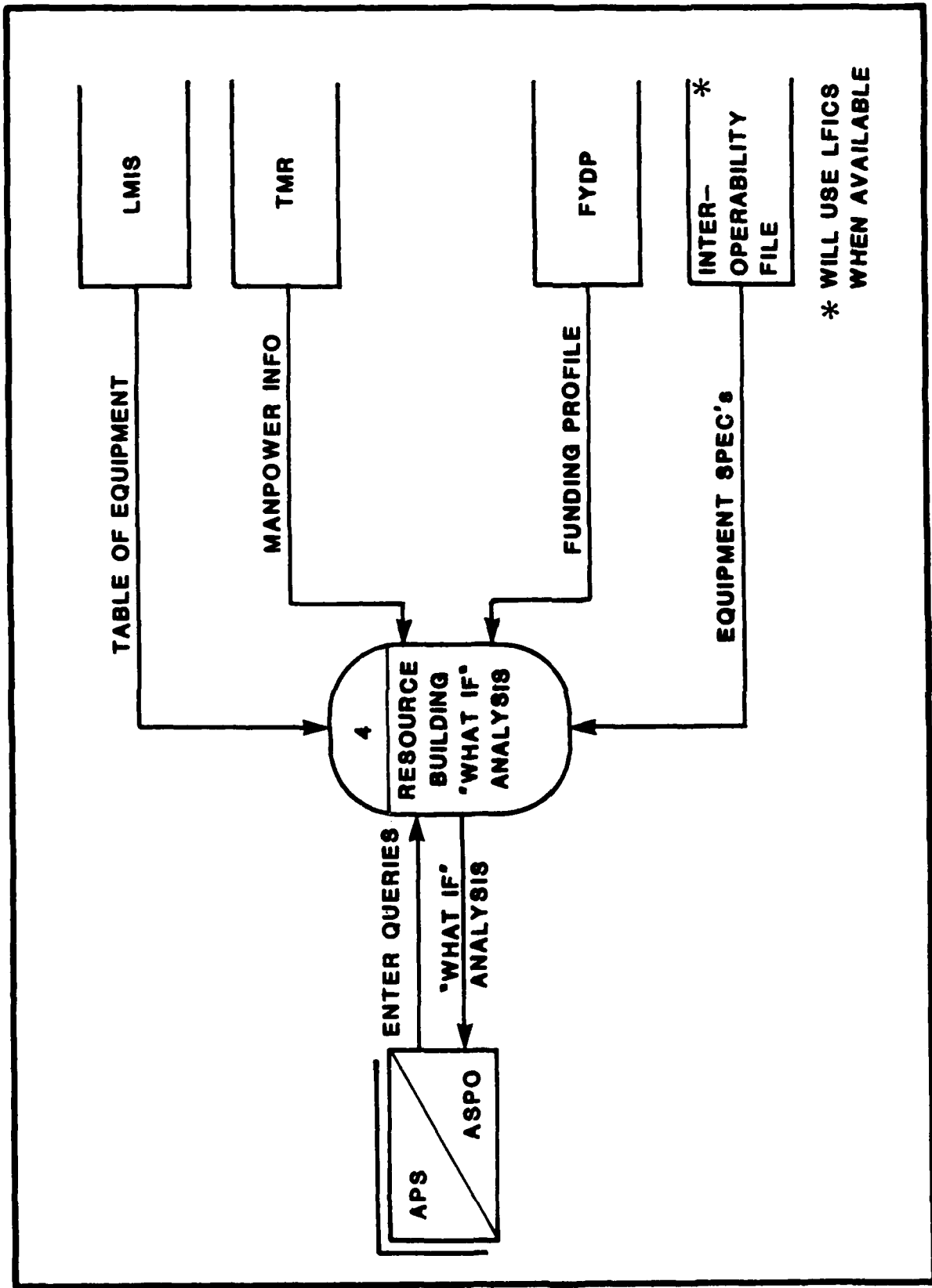

Figure 2.5. Resource Allocation Sub Module Data Flow Diagram

2.2.4.1 Logistics Management Information System (LMIS) Access File. This file will be specially constructed to access the LMIS data base so that information concerning equipment distribution can be withdrawn, displayed, and manipulated. This file will be utilized whenever adjustments to equipment distribution or fielding may be necessary to accommodate changes in funding levels, production schedules, or priorities. This file will include a capability to construct a new Table of Equipment (T/E) or Letter of Adoption and Procurement (LAP) input which can be locally printed but will not have the capability to write into the LMIS data base. All ACG members will be able to utilize this file.

2.2.4.2 Table of Manpower Requirements (TMR) Access File. This file will be constructed to access the TMR data base so that information concerning manpower resources associated with project implementation can be withdrawn, displayed, and manipulated. This file will be utilized whenever adjustments to manpower may be required to accommodate changes in resource levels or production schedules. All ACG members will have access to this file.

2.2.4.3 FYDP File. This file, shared with the PPBS sub module, contains FYDP funding and manpower data. When this file is used as part of the Resource Allocation Sub Module, system users will have access to project funding data indexed either by total program cost or by appropriation in any combination of program years maintained in the file. For example, all costs of a program may be compared over several years, or cost detail for a particular appropriation can be displayed. By manipulating this data, alternatives can be developed

for the accommodation of funding adjustments and construction of revised cost detail breakouts. All USMC ACG members should have access to this file.

2.2.4.4 Interoperability File. This file contains equipment interoperability data and will perform two functions.

- o Store a list of selected technical parameters for equipment being procured under each acquisition project. Required parameters:
 - oo Nomenclature
 - oo TAM Number
 - oo Frequency Range
 - oo Power Output
 - oo Bandwidth
 - oo Channel Spacing
 - oo Bit/Data Rates
 - oo Modulation
 - oo Data Ports
 - oo Standard Interface Capability
 - oo Input Power
 - oo COMSEC Interface

- o Interface with the Landing Force Integrated Communication System (LFICS) Model data bases being developed at MCDEC.

This interface shall permit a "system evaluation" capability to determine how any given project interoperates with other USMC equipments and to validate operational concepts.

3.0 System Design Specification

The C³ Planning and Management Information System architecture is based on a microcomputer Local Area Network (LAN) linked to current Marine Corps main frame computers which provide access to existing Class I data bases. Existing communications networks will provide system users the ability to share files and exchange information.

3.1 Hardware/Software Requirements

All of the Marine Corps automated data processing equipment which support the major AISS is IBM compatible and uses IBM compatible operating system software. The large master data bases maintained at the MCCDPA sites are composed of standard data base elements. ACG members require information from the data bases located at MCCDPA, Quantico, and MCCDPA, Albany.

3.1.1 Hardware Requirements. Existing hardware available for the C³ Planning and Management Information System consists of microcomputers located at HQMC, Code CCT and main frame computers at MCCDPA, Quantico, Va. Available equipment, as listed below, is available for use by the prototype system. Exceptions shall only be made based on technical compatibility issues and must be fully justified.

--CURRENT TECHNICAL REPORTS STATS PAGE 1 OF 2 JUN 26, 1986

NO FINDS END OF LEVEL 2

--TOTAL-SEARCH FINDS**-----	0	ARMY--	0
-- FIRST LEVEL FINDS**-----	118	NAVY--	0
-- FIRST AND SECOND LEVEL FINDS**----	0	AF----	0
-- 1+2+3 LEVEL FINDS**-----	0	OTHER-	0
-- 1+2+3+4 LEVEL FINDS**-----	0		

--SEARCH	KYL21B	FINDS-	0
--TIME OF DAY	11:21:18	COMPUTER TIME	.4

--FINDS** REPRESENT NUMBER OF ACCESSIONS RETRIEVED
--EXCLUDING DUPLICATES

<<P, C, OR W FOR ADDITIONAL STATISTICS>>

uscfwps@

MSG RECEIVED

-- 1 OF 1

-- 1 - AD NUMBER: A167246

-- 5 - CORPORATE AUTHOR: HUMAN RESOURCES RESEARCH ORGANIZATION ALEXANDRIA VA

-- 6 - UNCLASSIFIED TITLE: DEVELOPMENT OF PARALLEL LEARNING STRATEGIES CURRICULA USING VIDEO DISC AND STANDARD OFF-LINE FORMATS.

-- 9 - DESCRIPTIVE NOTE: FINAL REPT. SEP 83-DEC 85,

-- 0 - PERSONAL AUTHORS: RAMSBERGER, PETER F. ; HARRIS, CAROLYN D. ; KNERR, C. M. ; HOPWOOD, DAVID ;

-- 11 - REPORT DATE: DEC , 1985

-- 14 - REPORT NUMBER: HUMRRD-FR-PRD-85-16

-- 15 - CONTRACT NUMBER: MDA903-83-C-0453

-- 20 - REPORT CLASSIFICATION: UNCLASSIFIED

-- 34 - SOURCE SERIES: F

-- 35 - SOURCE CODE: 405260

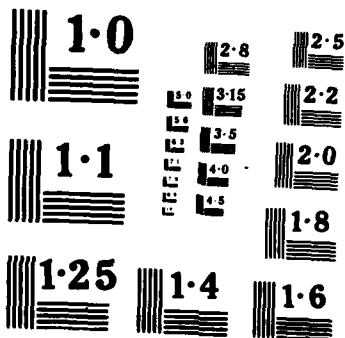

- o HQMC, Code CCT

- (1) Three AT&T 6300 PC's (w/512K RAM, one floppy disk, one 10 Meg Hard Disk, one 120 cps dot-matrix printer) and one AT&T 6300 PC on order
- (2) Three TEMPEST IBM PC-XT on order (with two dot matrix/one letter quality printer)
- (3) One IBM PC-XT (w/letter quality printer) on order

- o MCCDPA Quantico, VA

- (1) AMDAHL 470/V8A and 470/V8 CPU's
- (2) IBM 4341 Main Frame
- (3) NCR COMTEN

3.1.2 Software Requirements. Software selected for the C³ Automated Planning and Management Information System must possess the capability to perform the following functions:

- (1) Data Base Management
- (2) Project Management
- (3) Report Generation/Graphics
- (4) Spread Sheet
- (5) Word Processing

(6) Electronic Mail/File Transfer

(7) Calendar Mangement

3.1.3 Software Availability. HQMC, Code CCT currently has the following software packages available for use with the C³ Automated Planning and Mangement Information System. These software packages will be utilized by the prototype system unless alternatives can be fully justified.

Word Processor:

Microsoft Word

Volkswriter Deluxe

Spread sheet:

Lotus 123

Database Manager:

dBase II

dBase III

DATAMANAGER

Scheduler:

PERT Master

Communications Software:

AT&T 4410 Emulation Package

QMODEM

PC-TALK (IBM 3301 Emulation)

3270 Terminal Emulation

Graphics:

DR Draw

DR Graph

Project Management:

Integrated Management Planning and Cost Tracking (IMPACT)

Available through HQMC, Code LMA Contract Time Sharing)

3.2 Network Design

The prototype system network (Figure 3.1) consists of the physical layout of system subscribers and network components. Network components include all hardware and software necessary to connect the individual workstations within a single office to provide access to centralized file storage and facilities, to allow users to communicate with each other via electronic mail, and to communicate with other locations via common carrier communication facilities. "Workstations" refer to computers for the use of one person at a time in performing tasks related to office automation, processing, and project management. The LAN system must also provide, as a function of either the network or the workstations, communication with selected main frame computers now used by the Marine Corps. The prototype will follow the IEEE

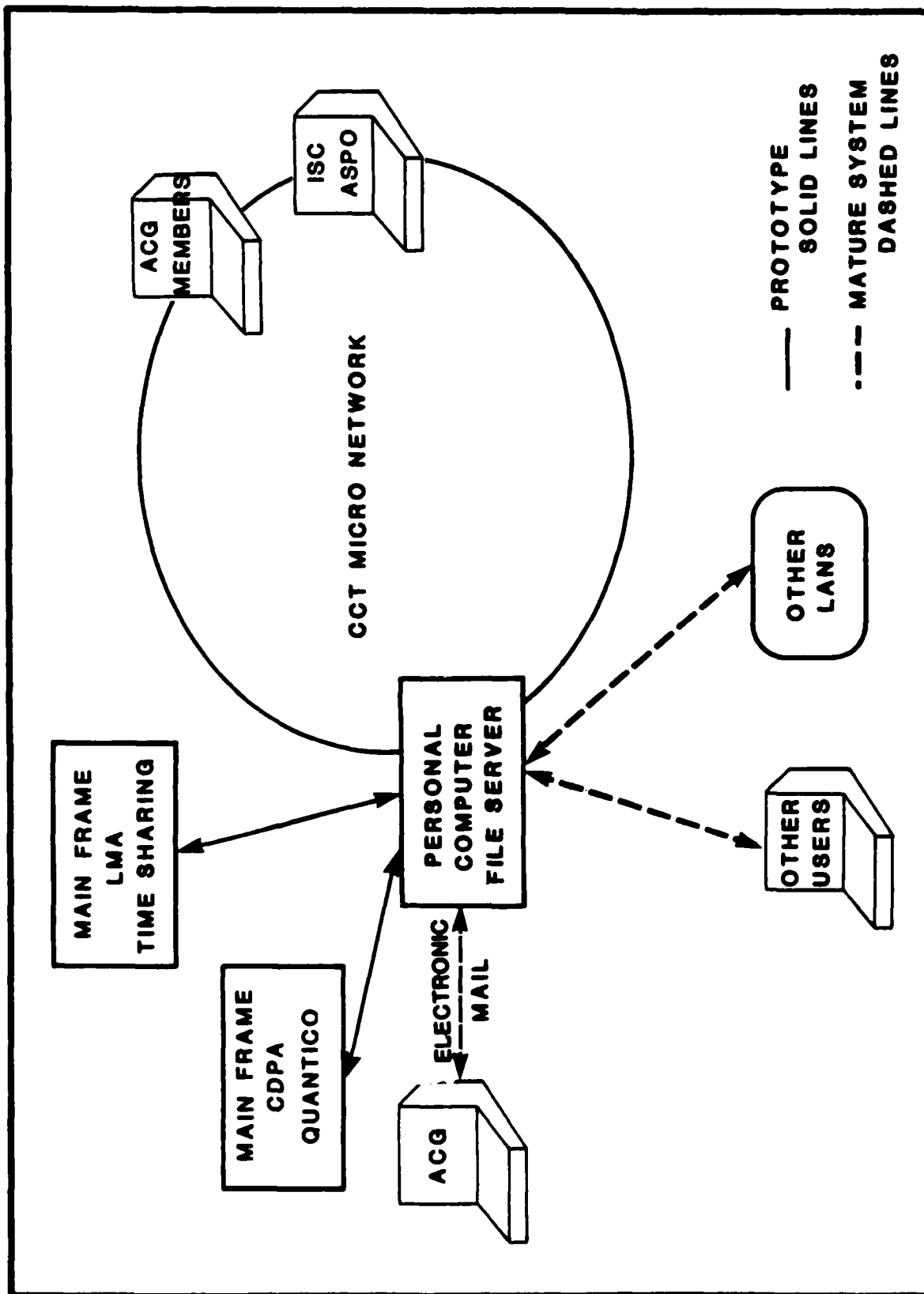

Figure 3.1. Prototype System Network

802 Standard for LAN communications. The prototype network will represent the linkage of members of the ACG as listed below: (All members of the ACG will be simulated in the prototype system by a systems integrator. One ASPO will be available to provide technical guidance on request)

<u>MEMBER</u>	<u>LOCATION</u>	<u>RESPONSIBILITY</u>
ASPO	HQMC	System Advocate/Recorder
APO	HQMC	Supportability
DPO	MCDEC	RDT&E Management
DC	HQMC	Monitor R&D
MPOC	HQMC	Advise on Manpower
TRO	HQMC	Advise on Training

Workstations will serve a very broad range of application requirements by appropriate programming. They are not intended to replace the large computers that the Marine Corps now uses for its major Class I system processing, but rather to extend and supplement these facilities by providing highly responsive interactive facilities as implied in the End User Computing Guidelines. To support the Marine Corps long-range plans for interactive systems development, the workstations must use portable operating systems, compilers, and application software packages and must be able to run a broad variety of packages from third-party software development companies.

3.3 Network Components

The LAN shall consist of shared devices and network management software.

3.3.1 File Facility. A shared file facility will be established which can be used by all work- stations on the LAN and which provides for storing and archiving text, graphics, programs, and data, according to the following specifications:

- o The shared file facility will be able to store at least 30 megabytes of data after its own operating software is loaded
- o There will be the ability to establish libraries of Marine Corps software and to transfer executable programs on demand from the file storage facility to individual work- stations for execution. These libraries will be limited in size only by the capacity of the shared file facility
- o There will be a facility for back-up and archive operations for data and program files. The network file storage facility will provide back-up and archive functions for the workstations

3.3.2 Workstations. The LAN system will use two personal computers which can meet the full array of application requirements listed in this system specification as the workstations for the system. The small computers used as the workstations will have the following basic characteristics:

3.3.2.1 Display. The screen display will have the following capabilities:

- o At least 24 lines by 80 characters with each character at least 6 x 9 dots with a least 2 dot descenders
- o A graphics mode size of approximately 350 x 700 dots or more
- o At least a 60 Hz refresh rate to eliminate flicker in normal use

3.3.2.2 Keyboard. S QWERTY keyboard with 88 characters and controls substantially consistent with the defacto office standard for office typewriters for use by touch typists will be utilized and have the following capabilities:

- o At least 10 programmable function keys, cursor control keys, or equivalent pointing device
- o Escape, control, and break keys

3.3.2.3 Computer. The workstation will have sufficient memory to run the advanced, integrated packages now available for spread sheet, graphics, word processing and data filing operations. Memory must be sufficient to support large (64K) spread sheet models and provide as fast response as is practical. To accommodate anticipated developments in this application area during the system's life cycle, the workstation shall have the capability to increase to at least 512K memory capacity.

3.3.2.4 Disk Storage. At least 10 megabytes (unformatted) of hard disk storage. All software must be storable on and executable from the hard disk. One 5-1/4 inch floppy disk drive shall be provided.

3.3.2.5 Printers. Each workstation shall be capable of supporting up to two printers of the following characteristics:

- o Letter quality at a minimum speed of 30 CPS
- o Draft quality and graphics at a minimum speed of 120 CPS
- o Underlining and at least two dot descenders are required, and the graphics resolution must be sufficient to print the contents of the display screen. 10 and 12 pitch type styles and 132 character print lines must be provided. Each printer shall include an adjustable pin-fed forms tractor with the capability to use paper from 4-1/4" to 12-1/4" wide (pin to pin)

3.3.2.6 Operating System. One of the following operating systems will be provided as the primary operating system (in alphabetical order):

- o CP/M-86 (Digital Research)
- o MS-DOS 3.0 (Microsoft)
- o UNIX or a UNIX-like system only if the shell has been specifically designed for use by professional, technical and clerical personnel who are not trained computer programmers

3.3.3 Communication to Main Frame Computers. The LAN will provide for data communications between workstations on the LAN system and the main frame

computer centers used by Marine Corps. This will be done by providing the following terminal emulation and communication protocol facilities and software.

3.3.3.1 Asynchronous Interactive Terminal Emulation. Asynchronous interactive terminal emulation using the ASCII code set and the TTY protocol will provide for the following:

- o 300 and 1200 bps line speed
- o The capability to transmit data from a workstation's hard disk storage to the main frame computer, as well as directly from the keyboard
- o The capability to receive data from the main frame computer to the workstation's hard disk storage, as well as to the workstation's display. Data received from the main frame computer must be stored in a form that is retrievable by the workstation's local programs
- o A facility which translates the word processing software's formatting codes into ASCII codes recognized by the main frame computer so that a "print image" of the data is transmitted
- o A functional single key BREAK key

3.3.3.2 RJE Terminal Emulation Using Bisynchronous Protocols. Implementation of RJE terminal emulation will provide for the following:

- o 4800 and 9600 bps line speeds
- o The capability to transmit data from a workstation's hard disk storage to the main frame computer
- o The capability to receive data to a workstation's hard disk storage and to a printer or printers on the LAN. The RJE printer facility must support up to 132 character print positions and upper and lower case printing

RJE terminal emulation may be provided either at the individual workstations or as a network service which is useable by all workstations on the LAN.

3.3.3.3 3270 Terminal Emulation. 3270 terminal emulation will use the SDLC protocol. Implementation of 3270 terminal emulation shall provide for the following:

- o 4800 and 9600 bps line speed
- o A facility on each LAN which serves as the equivalent of the IBM 3276 Model 12, 13, or 14 controller which features 9082 (EBCDIC character set), 6302 (communications feature without business machine clock), and 3701 (external modem interface), or an IBM 3274 Model 51C Controller which features 9112 (configuration support C), 6302, and 3701
- o 3270 terminal emulation on each workstation for use with controller required in paragraph above

3.4 Application Software

Application software packages are required for word processing, electronic spread sheets, graphics/report generation, calendar management, data base management, project management and electronic mail.

3.4.1 Word Processing Word processing software packages shall include the following features:

- o Full screen editing, which is the ability to edit text by manipulating the screen image using cursor control and function keys
- o Movement of the cursor left and right one character, up and down one line, to the top of the page, and to the top of a specified page
- o Automated word wrap around during text entry and reformatting
- o Scrolling through text horizontally and vertically. Horizontal scrolling shall provide for at least 132 character positions. Vertical scrolling shall provide for both forward and reverse scrolling, either line-by-line or screen-load by screen-load
- o Formatting of text, including:

- (1) Setting left and right margins, including multiple sets of margins on a page
 - (2) Setting and clearing tabs
 - (3) Inserting page breaks
 - (4) Automatic centering of text
- o Editing of text, including:
- (1) Inserting new text at any point in a document and automatic reformatting of the document upon completion of the insert
 - (2) Deleting text, including one character, one word, and through a specified point in the document, and automatic reformatting of the document upon completion of the delete
 - (3) Moving a specified block of text to any other position in the same document, and automatic reformatting of the document upon completion of the move
 - (4) Copying a specified block of text to any other position in the same document, and automatic reformatting of the document upon completion of the copy
 - (5) Copying a specified block of text to a specified position in another document, and automatic reformatting of the receiving document upon completion of the copy

- (6) Finding a specified string of text within the document.
 - (7) Automatic underlining of text
 - (8) Automatic placing of headers and footers in a document.
 - (9) Automatic page numbering at either the top or the bottom of the page
- o Printing of documents, including the following features:
 - (1) Print the complete document
 - (2) Print a specified page of the document
 - (3) Print multiple copies of the document or the specified page
 - (4) Print in background operation so the workstation can be used for other functions while a document is printing
 - o Filing of documents, including the following features:
 - (1) Naming of documents
 - (2) Storing of documents on the workstation's local hard disk storage
 - (3) Renaming of documents
 - (4) Deleting specified documents
 - o A facility for moving and copying from the specified program of the word processing program and then editing and reformatting of the data using the word processing software.

- o The ability to accept key strokes without data loss at a rate at least equivalent to a typist speed of 100 words per minute

3.4.2 Electronic Spread Sheet Electronic spread sheet software will include the following features:

- o The ability to handle large models, i.e., to use the full memory available in the workstation
- o The ability to add dollar signs, commas, and decimal points to selected cells
- o The ability to consolidate multiple models, e.g., to post or summarize values from one spread sheet to another
- o The ability to store data in a format that makes it accessible to other programs and systems
- o The ability to incorporate all or part of a model into a document being created using the text editor
- o The ability to route data to the graphics program

3.4.3 Graphics/Report Generation. Business graphics will include software which can use data from the spread sheet program or from data files and produce labeled bar, pie and multi-line charts. Directed-graph type graphics will include software which can be used to create organizational charts, precedence diagrams, milestone charts, data flow diagrams, etc.

3.4.4 Calendar Management. A calendar management package will include software which can create, maintain and query data-oriented lists and can be used to establish "suspense" or "tickler" files.

3.4.5 Data Base Management. Data Base Management System (DBMS) to support interactive data collection, entry, editing, review and maintenance of data. The DBMS must have both a host language interface, e.g., PASCAL, PL/1, COBOL, etc., and an end user interface which can be used by non-ADP personnel. The following additional specific features are required:

- o To support data independence, a separate data definition which drives all data operations. This language must be usable interactively for the creation and maintenance of data definitions and must support network, hierarchical and relational structures with one to one, one to many, many to one and many to many relationships
- o Features necessary to support data maintenance, integrity and security including:
 - (1) Data security and password protection at the data item level
 - (2) Transaction logging and data base recovery procedure

- (3) Conditional updates with a backout capability
 - (4) A data base reorganization and structural maintenance facility which is easy to use
 - (5) Collection of usage statistics for optimization
- o The retrieval capabilities must include:
- (1) Support for the creation of alternate views
 - (2) Support for multiple data bases
 - (3) A report writer
 - (4) The ability to interface with non-data base file structures

3.4.6 Project Management. A project planning and scheduling capability that provides GANTT, PERT, or CPM network analysis and tabular and graphic display shall be provided for the LAN. Interactive network creation and updating shall be provided.

3.4.7 Electronic Mail. Software that provides for exchanging messages and files between users via electronic mail will be provided and possess the following capabilities:

- o Create, send, receive, reply to, and dispose of messages
- o Include or attach any type of file
- o Create, maintain and use distribution lists
- o Address mail to users of C⁴ Acquisition System LANs

APPENDIX A
FILE DESCRIPTION
DATA ELEMENTS

FILE NAME: C4 Priority List

ABSTRACT DESCRIPTION: Contains listing of C4 acquisition projects which can be displayed by Total Project Cost or cost by Individual Appropriation. FYDP cutoff can be overlaid on project total cost listing to indicate funded projects.

<u>DATA ELEMENTS</u>	<u>DATA TYPE</u>	<u>RECORD LENGTH</u>	<u>COMMENTS</u>
1. Baseline	A/N	5 positions	
2. Designator	N	5 positions	
3. FYDP Priority	N	3 positions	
4. Initiative Descrp	A/N	16 positions	
5. New Start	A	1 position	
6. Sponsor	A	1 position	
7. Target FY(TFY) Cost	N	5 positions	Note 1, 5
8. TFY + 1 Cost	N	5 positions	Note 1, 5
9. TFY + 2 Cost	N	5 positions	Note 1, 5
10. TFY + 3 Cost	N	5 positions	Note 1, 5
11. TFY + 4 Cost	N	5 positions	Note 1, 5
12. Total Proj Cost	N	6 positions	Note 1, 2, 3
13. Total TFY Cost	N	7 positions	Note 3, 5
14. Total TFY + 1 Cost	N	7 positions	Note 3, 5
15. Total TFY + 2 Cost	N	7 positions	Note 3, 5
16. Total TFY + 3 Cost	N	7 positions	Note 3, 5
17. Total TFY + 4 Cost	N	7 positions	Note 3, 5
18. FYDP Cutoff TFY	N	7 positions	Note 4
19. FYDP Cutoff TFY+1	N	7 positions	Note 4
20. FYDP Cutoff TFY+2	N	7 positions	Note 4
21. FYDP Cutoff TFY+3	N	7 positions	Note 4
22. FYDP Cutoff TFY+4	N	7 positions	Note 4
23. C4 FYDP TFY	N	7 positions	Note 6
24. C4 FYDP TFY+1	N	7 positions	Note 6
25. C4 FYDP TFY+2	N	7 positions	Note 6
26. C4 FYDP TFY+3	N	7 positions	Note 6
27. C4 FYDP TFY+4	N	7 positions	Note 6

NOTES:

1. This data element is for each C4 project.
2. This is the total for each C4 project across all FYDP years.
3. This is the total cost of all C4 projects.
4. This is the total cost of all projects in the FYDP.
5. This data element must be repeated for each C4 project, or FYXX totals of all C4 projects, as follows:
 - a. Project total cost
 - b. Project RDT&E cost
 - c. Project PMC cost
 - d. Project O&MMC cost
 - e. Project O&MMCR cost
 - f. Project MCSF cost
6. This is the total cost of all C4 projects in FYDP.

APPENDIX A

FILE DESCRIPTION
STANDARD REPORT FORMAT

C4 PRIORITY LIST
PMC (\$M)

BASELINE: 87POM

DESIG	PRI	INITIATIVE	S	B	FY 87	FY 88	FY 89	FY 90	FY 91	TOTAL
11 - 1	005	MIFASS	N	A	96.8	109.6	119.8	127.8	142.4	673.8
11 - 2	008	TCO	N	A	- - -	- - -	176.0	299.0	117.3	719.3
11 - 3	014	JTIDS	N	A	- - -	- - -	45.7	14.8	15.1	98.7
11 - 5	036	NAVSTAR GPS	N	T	9.7	4.7	1.1	0.6	- - -	19.7
12 - 1	042	AN/MS - 63A TCC	N	T	- - -	18.0	17.2	2.1	0.4	40.2
12 - 2	055	SINGARS	Y	T	- - -	87.6	89.0	89.4	94.9	365.9
12 - 4	056	AN/TRC - 170	N	T	- - -	50.8	66.0	69.9	4.8	200.1
12 - 7	060	ULMS	N	T	25.6	22.8	0.6	0.3	4.5	64.9
12 - 12	097	RC - 292 ANT MOD	Y	T	0.5	0.1	- - -	- - -	- - -	0.5
12 - 15	109	LOW RATE MUX MOD	Y	T	2.2	0.1	- - -	- - -	- - -	2.3

** TOTALS **

ALL C4 PROJ	150.2	361.6	603.5	693.5	576.0	- - -
C4 PROJ IN FYDP	135.6	289.1	402.5	457.2	435.0	- - -
FYDP CUTOFF	- - -	- - -	- - -	- - -	- - -	- - -

NOTES

1. Projects and cost listed are for example purposes only to depict the types of data elements required in this file.
2. Totals listed have no mathematical relation to the example initiatives listed for display purpose.
3. For example purposes, this display is a C4 Priority List of PMC Initiatives. The capability to display a C4 Priority List by any other fiscal appropriation and by total project cost (sum of all appropriations) is also required. Screen/report format for each display will be identical.
4. The "FYDP CUTOFF" total line is only utilized in the Total Project Cost display.

APPENDIX A
FILE DESCRIPTION
SAMPLE STANDARD SCREEN MENU

Ext 340-B

100

TEXT TASK SELECTION

ID	ITEM
a	Create Document
b	Revise Document
c	Paginate Document
d	Print Document
e	Spelling Tasks
f	Merge Documents Tasks
g	Merge with File Task
h	Create File Description
i	Revise File Description
j	Document Utilities
k	Profile Tasks
l	DOS Command Task
z	Return To DOS

Type file description name; press ENTER:

Create File Descr. DW3.DES

Ext 340-B

100

CREATE OR REVISE FILE DESCRIPTION

ID	ITEM
a	Create Field Descriptions
b	Revise or Display Field Descriptions
c	Delete Field Descriptions

When finished with this menu, press ENTER.

Type ID letter to choose ITEM; press ENTER:

Revise File Descr. DW3.DES

Ext 340-B

100

CREATE OR REVISE FILE DESCRIPTION

- ID ITEM
- a Create Field Descriptions
- b Revise or Display Field Descriptions
- c Delete Field Descriptions

When finished with this menu, press ENTER.

Type ID letter to choose ITEM; press ENTER:

Create Field Descr. DW3.DES

Ext 340-B 100

FIELD DESCRIPTION

ID	ITEM	YOUR CHOICE	POSSIBLE CHOICES
a	Field Name		
b	Field Type	2	1 = Numeric 2 = Character
c	Length	200	1 - 17: Numeric 1 - 500: Character

When finished with this menu, press ENTER.

Type ID letter to choose ITEM; press ENTER:

Revise File Descr. DW3.DES

Ext 340-B 100

CREATE OR REVISE FILE DESCRIPTION

- ID ITEM
- a Create Field Descriptions
- b Revise or Display Field Descriptions
- c Delete Field Descriptions

When finished with this menu, press ENTER.

Type ID letter to choose ITEM; press ENTER:

Field description contains no fields. Task cancelled.

APPENDIX B
INFORMATION SOURCES AND DATA ELEMENTS

TABLE OF CONTENTS

Section	Page
1. Introduction.	B-1
1.1 Purpose.	B-1
1.2 Assumptions.	B-1
1.3 Methodology.	B-2
2. Essential Information Elements.	B-3
2.1 Background	B-3
2.2 Current Efforts.	B-3
Annex 1 R&T MIRA Study Data Element List.	B-1-1
Annex 2 LCC Model Acquisition Activity Listing.	B-2-1
Annex 3 ASPO Data Element List.	B-3-1

List of Tables

Table	Page
B.1 Acquisition Documentation by Milestones.	B-3

1. Introduction

1.1 Purpose. This document identifies the essential information elements needed to perform the C³ planning function and recommends the technical data to be utilized in a C³ Automated Planning and Management Information System.

A survey was conducted of Marine Corps acquisition managers in the C⁴ Systems Division of Headquarters Marine Corps (HQMC) and the C³ Division, Marine Corps Development and Education Command (MCDEC) to identify the essential information elements needed to perform C³ planning and management functions. In addition, existing acquisition directives, policies, procedures, and related studies were reviewed. The document review and interviews identified data that should be utilized in a C³ Automated Planning and Management Information System.

1.2 Assumptions

Assumptions made in preparing this document are as follows:

- o Marine Corps acquisition directives and organizational structures will remain unchanged in terms of function and relationships.
- o Recommendations for an automated system will conform to existing Marine Corps directives and organizational relationships.

- o Development of a C³ Automated Planning and Management Information System will improve decision support to the Director, C⁴ System Division and provide improved acquisition management capabilities for the ASPO.

1.3 Methodology

The methodology used to identify the essential information elements needed to perform the C³ planning and management functions are summarized below:

- o Review of existing acquisition directives, policies, procedures and related contractual studies.
- o Visiting and observing principal members of the Acquisition Coordinating Group (ACG) in their work areas.
- o Conducting interviews and administering questionnaires to ACG members and other personnel responsible for the initiation, processing, or execution of acquisition documentation. This step identified documents of prime interest to the Acquisition Project Sponsor (APS).

2. Essential Information Elements

2.1 Background

As a result of the review of existing acquisition documentation and indepth interviews of ACG members, the types of information needed and the capabilities required in an automated system were identified. The documents which were reviewed identified discrete data elements which could be included in an automated data base. Table B.1 is a listing by milestone of the major documents required during the acquisition process.

In addition to the examination of acquisition documentation, a review of existing systems and methods being employed to satisfy current information requirements was conducted. This review included existing and planned Marine Corps AIS assets with special attention given to existing models and data bases which are used in management and decision making.

2.2 Current Efforts

Three efforts which have been initiated by the Marine Corps that relate directly to the C³ Automated Planning and Management Information System are the Research and Technology Management Information Requirements Analysis (R&T MIRA) Study of 15 October 1983; the Office Information Network

Table B.1 Acquisition Documentation by Milestone

PROGRAM INITIATION MILESTONE 0

MLRP Marine Corps Long Range Plan
 MMRP Marine Corps Mid-Range Objectives Plan
 MAA Mission Area Analysis
 TCP Technology Coordinating Paper
 JMSNS Justification for Major System New Start
 JSNS Justification for System New Start
 TAP Task Area Plan
 STO Science and Technology Objective
 DCP Decision Coordinating Paper
 EDG Exploratory Development Goal
 DROC Draft Required Operational Capability
 WD Work Directive
 AP Acquisition Plan
 ADM Acquisition Decision Memorandum

FULL SCALE DEVELOPMENT MILESTONE II

TPD Test Planning Document
 DD Form 1634
 APP Advanced Procurement Plan (R&D/PMC)
 ILSP Integrated Logistics Support Plan
 LAP Letter of Adoption/Procurement Part 2
 DCP Decision Coordinating Paper
 MTIA Manpower Training & Impact Analysis
 EA Economic Analysis
 ADM Acquisition Decision Memorandum
 ALO Preliminary Advanced Logistic Order
 DT/OT Development Test/Operation Test Reports
 TSP Training Support Plan
 SOW Statement of Work
 CDRL Contract Data Requirements List

DEMONSTRATION-VALIDATION MILESTONE I

ROC Required Operational Capability
 ADO Advanced Development Objective
 MIP Master Information File
 HCA HQ Commitment Authorization
 APP Advanced Procurement Plan
 ADM Acquisition Decision Memorandum
 AP Acquisition Plan
 T&E Test and Evaluation Reports
 TCP Technology Coordinating Paper
 COO Concept of Operations
 LAP Letter of Adoption/Procurement, Part 1
 MTIA Manpower & Training Impact Analysis
 RDOPP RDT&E Obligation Phasing Plan
 ADM Acquisition Decision Memorandum
 TEMP Test & Evaluation Master Plan
 SOW R&D Contract
 CDRL R&D Contract
 SPEC Development Specification
 RFP/IFB Request for Proposal/Invitation for Bid

PRODUCTION/DEVELOPMENT MILESTONE III

ALO Advanced Logistics Order
 RFP/IFB Request for Proposal/Invitation for Bid
 PWO Procurement Work Order
 MIPR Military Interdepartmental Purchase Request
 MCPR Marine Corps Purchase Request
 PO Purchase Order
 ILSP Integrated Logistics Support Plan
 QDR Quality Deficiency Report
 LAP Part 1&2 Update
 ILSP (Update)
 APP (Update)
 MTIA (Update)
 FOT&E Follow on Test and Evaluation Report

solicitation sponsored by the Development Center, MCDEC, and; a current task to develop a methodology to help members of the ACG develop and manage R&D and Acquisition Funding Plans under the Life Cycle Cost Model for Defense Materiel Systems sponsored by the Material Acquisition Support Branch, HQMC Code LMA.

The MIRA study identified the requirements for a system that will collect, disseminate, report, and retrieve RDT&E management information. The study developed a list of data elements and recommended responsible data base sources for the data elements. The data element lists developed from this study are displayed in Annex 1 of this document.

The Office Automation Network at MCDEC which will provide automated support, hardware, software and system maintenance to assist in performing the acquisition process functions of the Development Project Officer (DPO) has not been developed at this time, but will have an impact on the C3 Automated Planning and Management Information System during the prototype development.

The LMA sponsored task to develop and manage the R&D and Acquisition Funding Plans under the Life Cycle Cost Model provides a base line acquisition activity list. This list details each step in the acquisition cycle in the areas of acquisition management, configuration management,

computer support, contracting, programming, facilities, human factors, system engineering, logistics management, logistics support analysis, maintenance, manpower, packaging, quality assurance, reliability, availability and maintainability, support and test equipment, supply support, testing, technical documentation, transportation and training. The activity list can be tailored to a specific project based on its Acquisition Category (ACAT) status and decisions made by the APS. The activity listing has been included in Annex 2 of this document. Discrete data elements developed for each of the activities listed will be available from LMA upon completion of the contract task in September 1985.

Currently, there are over six hundred pages of data elements available. The R&D and Acquisition Funding Plans information will be available to LMA on a time sharing basis from a commercial source. This method was selected to eliminate conversion problems, minimize software maintenance costs, maintain configuration control of the model and to facilitate the sharing of data between Government and industry by electronic transfer of data bases.

The C³ Automated Planning and Management Information System will utilize the data elements from the MIRA and LMA studies as the foundation for a data base. This approach has two significant advantages:

- o The effort required to construct a data base will be minimized, and;
- o Commonality and interoperability between ACG systems could be achieved.

The MIRA and LMA data element listings were developed to support the activities of the Development Project Officer and Acquisition Project Officer and the Acquisition Project Officer. In addition, the documents prepared by ASPO's were reviewed, and the data elements needed to prepare these documents are included in Annex 3. When combined with the data element listings from the MIRA and LMA studies, the data elements contained in Annex 3 form the basis for the construction of a C³ Automated Planning and Management Information System data base.

- b. IPR
 - c. DNSARC
 - d. DSARC
 - e. Other
- 7. Development Category
 - a. Unilateral
 - b. Joint
 - c. DOD Directed
 - d. Other Service
 - 8. Requirement Documents
 - 9. Objective/Task Description
 - 10. Item Description
 - 11. References
 - 12. Enclosures
 - 13. Contractors/Producers
 - 14. Coordinating Commands/Agencies
 - 15. Historical Summary
 - 16. Development Summary
 - 16a. Milestone List
 - 17. Related Efforts
 - 18. Action
 - 19. Funding
 - 20. Cancellation

Document Title: RDT&E Obligation Phasing Plan for Approved Funding
(RDOPP)

Directive:

Other Authority: HQMC letter of instruction

Used by: HQMC, MCDEC

Comment: This document is in matrix form, showing the planned obligation of funds by month in the year of execution by sub project line, as well as the total for each month and the cumulative amount in each month. Also shown are the total amounts expected in the FYDP years, by sub project line.

Data Elements

1. Date
2. Fiscal year
3. Program Element No.
4. Project No.
5. Title
6. Subproject No/Title
7. Task
8. Location
9. Description
10. Performer

11. Obligation amounts per month of Execution FY
12. Planned Obligation total per month (vertical)
13. Planned Obligation cumulative total per month (vertical)
14. Total planned obligation per task (horizontal)
15. FYDP amounts by FY per task

Document Title: Headquarters Commitment Authorization (HCA), NAVMC 122
with Essential Data Element Summary

Directive: MCO P5000.10A

Other Authority: Memorandum instructions issued annually by DC/S, RD&S

Used by: MCDEC, HQMC

Comment: The key funding document for RDT&E projects which
require funds to be sent to another service and
projects involving contracting by HQMC, Code LBC

Data Elements

1. Date
2. Authorization No.
3. Amendment No.
4. Previous Amount
5. Increase/Decrease
6. New total
7. From
8. To
9. Funds Chargeable (Appropriation data)
 - a. Appropriation
 - b. Subhead
 - c. Object Class
 - d. BCN

- e. Sub Allotment
 - f. AAAN
 - g. Trans Type Code
 - h. PAAN
 - i. Cost Code
10. Description
- a. Project No/Title
 - b. Period of Performance
 - c. Obligation by date
11. Requested by
12. Approved by

Data Elements, Essential Data Element Survey (C)

1. Contractor/Performer
- a. Contract to be awarded by LBC
 - b. Funds forwarded to External Command
 - (1) In-house
 - (2) Contract Effort
 - (3) Indicate Command
2. Sole Source Justification
- a. Applicable
 - b. Not applicable
 - c. Justification
- 2a. Personal Services

- a. Applicable
 - b. Not applicable
 - c. Non-Personal Service Documentation Attached
3. Work Statement
4. Statement of Coordination
5. Deliverable Items
- a. Applicable
 - b. Not Applicable
 - c. Quantity
 - d. NSN
 - e. Description
 - f. DOD Address Code
 - g. Required Date of Delivery
 - h. Special P&P or Marking
 - i. Instructions
6. Reports Required
- a. Applicable
 - b. Not applicable
 - c. Describe
7. Data Package
- a. Contractor
 - b. Marine Corps
 - c. Not Applicable

- d. Describe Package Requested
- 8. Government Furnished Equipment Requirements
 - a. Applicable
 - b. Not Applicable
 - c. FSN
 - d. Description
 - e. Unit of Issue
 - f. Unit Cost
 - g. SAC Code
- 9. Force Activity/Urgency of Need Designators/Priority
 - a. FAD
 - b. UND
- 10. Patent Rights or Title Clause Required
 - a. Applicable
 - b. Not Applicable
 - c. Pre-award Patent Rights Documentation Checklist Attached
 - d. Explain
- 11. Remarks

Document Title: Registration of Estimated Deficiency (RED)

Directive: MCO 5000.10A

Other Authority:

Used by: HQMC, MCDEC

Comment: Used to secure funding not included in the current budget or FYDP.

Data Elements

1. Date
2. FY
3. Claimant
4. HQMC Sponsor
5. Project Number
6. Project No/Title
 - a. Sub-Project No/Title
7. Task
8. Amount (\$)
9. Purpose
10. Date Funds Needed
11. Type of Funding Document
12. Lead time to obligate (months)
13. Contracting Agency
14. Work Performer
15. Period of Performance (months)

16. \$ Expanded by end of performance period
17. Estimated Fund Usage
 - a. Unbudgeted Requirement
 - b. Subcontracts
 - c. Long Lead Items
 - d. Other
18. Type Contract
 - a. Firm Fixed Price
 - b. Cost Plus Incentive Fee
 - c. Cost Plus Fixed Fee
 - d. Purchase Request
 - e. Work Request (Government installation)
 - f. Basic Ordering Agreement
 - g. Performance Payments Authorized
19. Impact if not received
20. RDD recommendation
21. RDP comment
22. DC/S RD&S decision

Document Title: Requirements Review and Approval Format (RRAF)

Directive: MCO 4200.27

Other Authority:

Used by: HQMC, CNM, all USMC activities requiring contractor support services (CSS) as defined in the directive.

Comment: The RRAF must be submitted by the requiring activity to the appropriate approval authority for all requests for CSS in excess of \$50,000. The RRAF is submitted along with the proposed statement of work for CSS, a DD Form 1498, Research and Technology Work Unit Summary, and the document reserving the requested funds (HCA or PWO, as appropriate).

Data Elements

1. Project number
2. Project title
3. Date (of preparation)
4. CSS Category
5. Procurement Request Number
6. Description of CSS Required
7. Procurement Method (Type of contract)
 - a. Estimated Cost
 - b. Prior Procurement History
 - c. Contracting Officer Technical Representatives

8. Certification of Availability of Funds
9. Justification of Need to Procure CSS
 - a. Use of In House Resources
 - b. Other Government Resources
 - c. Retention of Essential Management Control
of the Program
 - d. Assessment of Services to be Construed as Being
Personal in Nature
10. Assessment of Decision to Procure Noncompetitively
(if applicable)
11. Certifications and Approvals (preformatted)

Document Title: Special Analysis Exhibit - Consultants, Studies and Analyses, and Management Support Contracts (Budget Exhibit PB-21)

Directive: Assistant Secretary of Defense (Comptroller) Special Budget Analysis (PB-21) letter directive

Other Authority: SECNAVINST 4200.31, MCO 4220.27, CMC ltr RDP-32-32-19-JMG of 30 Oct 81

Used by: MCDEC, HQMC, Chief of Naval Research

Comment: Document consists of a cover letter and an enclosure in columnar format which identifies funds budgeted for various categories of contractor support services (CSS) for the Marine Corps in the previous, current, and next Fiscal Year (FYs). The requiring directive is issued annually by the Assistant Secretary of Defense (Comptroller).

Data Elements

1. Appropriation
2. Date (of preparation)
3. Constant columnar headings
 - a. FY (last) (entries in \$000 by CSS category/subcategory)
 - b. FY (current) (entries in \$000 by CSS category/subcategory)
 - c. FY (next) (entries in \$000 by CSS category/subcategory)
4. CSS Categories, General Sub-categories, and Specific Subcategories

a. Experts and Consultants

(1) Personnel Appointments

(a) Experts

(b) Consultants

(1) Federal Advisory Committee Members

(2) All Other Appointed Consultants

(2) Contract Consultants

b. Contract Studies and Analyses

(1) Consulting Services

(2) Other

c. Professional and Management Services by Contract

(1) Program Management Support

a. Consulting Services *

b. Other *

* (These specific subcategories are applicable to all
general subcategories in Category C)

(2) Policy Review and Development

(3) Specification Development

(4) System Engineering

(5) Technology Sharing/Utilization

(6) Logistic Support Services

(7) Technical Data Collection

(8) Public Affairs and Advertising

- (9) Other Professional and Management Services by Contract
 - d. Contract Engineering Technical Services (CETS)
 - (1) Contract Plant Services
 - (2) Contract Field Services
 - (3) Field Service Representatives
 - e. Total (of all \$000 in all FY columns for Categories A through D)
 - f. Summary
 - (1) Personnel Appointments (in \$000 by FY)
 - (2) Contract Consulting Services (in \$000 by FY)
 - (3) Other Contract Services (in \$000 by FY)
 - (4) Total (of all \$000 in FY columns for items 1 through 3)
5. The enclosure to the PB-21 is entitled PB-21A and summarizes only those CSS categories in the PB-21 for which money has been budgeted. The PB-21A is a columnar display which includes data elements in the following format.
- a. Column headings
 - 1) Line item (Refers to CSS category and subcategory in a 2 or 3 digit code. Codes are keyed to the elements listed in paragraph 4 above. For example, funds budgeted for Contract Studies and Analyses (Category B) Consulting Services (subcategory 1) is displayed in "Line Item" as B1.)
 - 2) Program Element Number

- 3) Project Number/Title
 - 4) Constant columnar headings from PB-21
 - 5) Subtotal of \$000 by FY by Line Item
- b. Narrative justification/impact of funding action for selected projects
6. Promulgating letter correspondence reference data

Document Title: Master Information Paper (MIP)

Directive:

Other Authority: Specific instructions are published by memorandum each year when the POM guidance is issued.

Used by: HQMC, OPNAV, OSD

Comment: Used to support annual formulation of USMC input to Navy POM and budget. A one-page summary about a Program Element or a Project within a Program Element.

Data Element

1. Classification (Security)
2. Date
3. Sponsor (CMC Code)
4. Coordinator (CMC Code)
5. Project Manager (PDA)
6. Mission Area No/Title
7. PBD
8. BA
9. Acquisition Category
10. PEN¹ and Title
11. Project number¹ and Title
12. Requirement/Description (of Project)
13. Current Status (of Project)
14. Planned FY (next) Program

15. Planned FY (succeeding - fourth) Program
16. Major Milestones
17. Principal Performers
 - a. Contractors
 - b. Government
18. Funding Data Matrix
 - a. Horizontal column headings
 - 1) RDT&E, N (\$M)
 - 2) CFY
 - 3) Next FY
 - 4)-8)Succeeding FYs
 - b. Vertical column headings
 - 1) POM - CFY (as of :(mo/yr))
 - 2) (CFY) Navy Budget (as of: (mo/yr))
 - 3) (CFY) OSD Submission (as of: (mo/yr))
 - 4) (CFY) Presidential Budget (as of: (mo/yr))
 - c. column entries in decimals of \$M
19. Procurement Appropriations (A matrix similar to item 18 above)

Document Title: U.S. Marine Corps RDT&E, N POM
Directive: DoDI 7045.7
Other Authority: SECNAVINST 5000.16D
Used by: HQMC, DON, DOD, MCDEC
Comment: The most important planning document in the PPBS cycle with respect to the out years. A matrix document showing funds by fiscal year for each project.

Data Elements

1. POM year
2. Program element number and title
3. Project number and title
4. Funding by project per Fiscal Year for the 5 year POM period, in a matrix
5. Program element total
6. Total Marine Corps RDT&E, N per Fiscal Year
7. Promulgating letter correspondence reference data

Document Title: FY____ Marine Corps Allocation of RDT&E, N Funds

Directive:

Other Authority: HQMC promulgating letter

Used by: MCDEC, HQMC

Comment: Document consists of cover letter and funding allocation by project for all CFY USMC RDT&E projects in matrix form. Not a preprinted form. Promulgation may occur more than once in each FY.

Data Elements

1. Horizontal columnar headings
 - a. PEN/Project #
 - b. Title
 - c. As of date in (CFY) Budget
 - d. Increase (amount)
 - e. Decrease (amount)
 - f. As of date in (CFY) Budget
 - g. Note
2. Vertical column entries
 - a. PEN/Project #(s)
 - b. PE Title/Abbreviated Project Title
 - c. \$000 for c. above
 - d. \$000 for d. above, if applicable, and reason
 - e. \$000 in e. above, if applicable, and reason

f. \$000 in f. above

g.

h. (Reason) Codes (Applied to the \$000 entries)

- 1) A = Reprogramming
- 2) B = Congressional Approval Required
- 3) C = Program Element Total
- 4) D = Deferred by OSD
- 5) DR = Deferment Released
- 6) E = Program Element Realignmeant
- 7) F = Deferred by Navy
- 8) G = DC/S, RD&S Deferment
- 9) H = ASN, RE&S Action
- 10) I = Inflation
- 11) R = Reduction
- 12) S = Congressional Action
- 13) T = Travel

3. Cover letter correspondence reference data

Document Title: Order for Work and Services - NAVCOMPT FORM 2275

Directive: NAVCOMPTINST 7000.43

Other Authority:

Used by: HQMC, (RDP, FDA), MCDEC

Comment: Used to procure in-house work from Navy and Marine Corps performing activities. Data elements are numbered in document.

Data Elements

1. (Not used; contains instructions only)
2. Document Number
3. Reference Number
4. Funds Expire on
5. Work completion date
6. Date prepared
7. Amendment No.
8. From address
9. Point of Contact
10. To address
11. Billing address
12. Accounting data
 - a. ACRN
 - b. Appropriation
 - c. Sub head

- d. Object Class
 - e. Budget Control
 - f. Sub Allotment
 - g. AAA Number
 - h. Transaction Type Code
 - i. PAA Number
 - j. Cost Code
 - k. Amount
 - l. Total this document
 - m. Cumulative total
13. This order is issued as
- a. Project order
 - b. Economy Act order
 - c. Fixed Price basis
 - d. Cost Reimbursement basis
14. Description of Work to be performed
15. Authorizing Official/date
16. Accepting Official/date

Document Title: Request for Contractual Procurement - NAVCOMPT FORM
2276

Directive: NAVCOMPTINST 7000.43

Other Authority: MCO 4200.27

Used by: Organizations procuring contractor support services

Comment: Used in conjunction with RRAF. Following numbered data
elements correspond to numbered blanks on NAVCOMPT Form
2276.

Data Elements

1. Contracts Division Code/PWO No.
2. Document Number
3. Reference Number
4. Funds expiration date
5. DMS Rating
6. Priority
7. Date required
8. Amendment Number
9. From address
10. Point of Contact
11. To address
12. Invoice address
13. Accounting data
 - a. ACRN

- b. Appropriation
 - c. SubHead
 - d. Object Class.
 - e. Budget Control Number
 - f. Sub allotment
 - g. AAA Number
 - h. Trans Type Code
 - i. PAA/Number
 - j. Cost Code
 - k. Amount
 - l. Total this document
 - m. Cumulative total
14. (No data entry, information item only)
15. Procurement item description
- a. ACRN
 - b. Item No.
 - c. Federal Supply Category
 - d. Description
 - e. Quantity
 - f. Unit
 - g. Estimated unit price
 - h. Estimated amount
 - i. Grand total

16. (No data entry, information item only)
17. Transportation allotment
18. Authorizing Official/date
19. Accepting Official/date

Document Title: Claimant Program Proposal (CPP)
Directive: MCO 3900.12A
Other Authority: NAVMATINST 3910.20A
Used by: MCDEC, HQMC, (RD&S), Chief of Naval Development, ASN
(RE&S), USDR&E
Comment: The CPP is a five year program plan and is the formal documentation used in developing the Marine Corps Exploratory Development Program. The purpose of the CPP is to ensure that resources allocated for Marine Corps exploratory development are properly identified and assigned.

Data Elements

1. Title (POM Yr)
2. Originator (Claimant Technology Base Manager)
3. Approval (Claimant approving authority)
4. Program Overview
5. Technology Option Descriptions
6. Claimant Base Program Fiscal Summary
 - a. PEN
 - b. Subproject
 - c. Title
 - d. Budget Year (\$ by PEN & Subproject)
 - e. BY + 1 (\$ by PEN and Subproject)

- f. BY + 2 (\$ by PEN and Subproject)
 - g. BY + 3 (\$ by PEN and Subproject)
 - h. BY + 4 (\$ by PEN and Subproject)
 - i. BY + 5 (\$ by PEN and Subproject)
 - j. Total Base Program (\$ by BY through BY + 5 totals)
7. Technology Option Fiscal Summary
- a. PEN
 - b. Technology Option Title (TOT)
 - c. BY (\$ by PEN & TOT)
 - d. BY + 1 (\$ by PEN & TOT)
 - e. BY + 2 (\$ by PEN & TOT)
 - f. BY + 3 (\$ by PEN & TOT)
 - g. BY + 4 (\$ by PEN & TOT)
 - h. BY + 5 (\$ by PEN & TOT)
 - i. Total Proposed Technology Options (\$ by BY through BY + 5 totals)
8. Issues
9. Funding (\$ by FYDP, base, and margin for each alternative)
10. Cover letter correspondence reference data

Document Title: Subproject Program Plan (SPP)

Directive: MCO 3900.12A

Other Authority: NAVMATINST 3910.20A

Used by: MCDEC, HQMC (RD&S), Chief of Naval Development, ASN
(RE&S), USDR&E

Comment: The SPP is based upon the Claimant Program Proposal
(CCP) and presents in more detail the plans for
execution of the budget year program on an annual
basis.

Data Elements

1. Subproject Number
2. Subproject Title
3. Responsible Individual
4. Administering Office Approval
5. ONT Approval
6. Naval need
7. Technical Problem
8. Technical Approach
9. Payoff
10. Task Description (for each task)
11. Funding
 - a. Task number
 - b. Current year (\$ by Task number)

- c. Budget year (\$ by Task number)
 - d. BY + 1 (\$ by Task number)
12. Milestones (consists of graphic time line display)
- a. Milestone Title
 - b. Execution Year (by quarter)
 - c. Budget year
 - d. BY + 1
 - e. Current fiscal year SPP Milestone titles
 - f. Current fiscal year by month
13. Cover letter correspondence reference data

Document Title: FY ____ RDT&E Descriptive Summary (Common Title: PEDS
(Program Element Descriptive Summary)

Directive:

Other Authority: DC/S, RD&S

Used by: HQMC, MCDEC, DON, DOD

Comment: The PEDS provides a detailed summary of the projects listed under each program element by FY. The PEDS concentrates on project funding status and the past, current, and future FY actions taken or planned within each project.

Data Elements

1. PEN
2. PE Title
3. Mission Area
4. Budget Activity
5. FY (next) Resources (Columnar listing of projects under the PEN, project titles, and funding profile for each project.)
 - 1) Project number
 - 2) Project title
 - 3) FY (past) Actual (\$000 allocated to each project)
 - 4) FY (current) Estimate (\$000 allocated to each project)
 - 5) FY (next) Estimate (\$000 allocated to each project)
 - 6) FY (succeeding) Estimate (\$000 allocated to each project)
 - 7) Additional to Completion (\$000 required to complete each project)

- 8) Total Estimated Cost (\$000 total of elements 3) through 7)
above by project)
- 9) Total for Program Element (\$000 total for PE by FY)
6. Description of Element and Mission Need
7. Comparison with FY (current) Descriptive Summary
8. Funding as Reflected in the FY (current) Descriptive
Summary (contains all elements listed in element 5 above)
9. Other FY (current) Appropriations Funds (contains all
elements listed in element 5 above)
10. Related Activities (Identifies all other existing or
developmental systems to which the projects within
this PE are related.)
11. Work Performed by:
 - a. In house (all military agencies performing and their
locations)
 - b. Contractors (all contractors performing and their
locations)
12. Projects Less Than \$10 Million in FY (next):
(Narrative summary of actions taken or planned for each
applicable project by past, current, and future FY).

Document Title: Test Support Package (TSP)

Directive: MCO 5000.11A

Other Authority:

Used by: HQMC, MCDEC, MCOTEA

Comment: This is not a document, per se, but is a collection of documents. The TSP "document" may consist of a cover letter with a list of the documents included in the package.

Data Elements

1. Cover letter correspondence identification data
2. Approved threats and scenarios
3. Concept of Employment
4. Organizational Concept
 - a. T/Os
 - b. T/Es
5. Logistic Support System
6. Training Concept

Document Title: Test Planning Document (TPD)
Directive: MCO 5000.11A
Other Authority:
Used by: HQMC, MCDEC
Comment: Used to provide an estimate of FMF resources required
in support of a testing program.

Data Elements

1. System Identification
 - a. Title and type test
 - b. Project Number
 - c. Program Element
 - d. System Description
 - e. System Mission
 - f. Milestone Review
 - g. Points of contact
 - (1) Sponsor
 - (2) APO
 - (3) DC
 - (4) DPO
 - (5) Operational Test and Evaluation Project Officer
 - (6) Other
 - h. Source Documentation
 - (1) DOD Directive for System

- (2) GOR
 - (3) ROC
 - (4) DCP
 - (5) Prior Test Reports
 - (6) Study Reports and other documents
- 2. Objective/Operational Issues
 - 3. Test Concept
 - 4. Test Resource Requirements
 - a. Test items/support equipment and supplies
 - b. Ranges/Facilities
 - c. Personnel
 - d. Training
 - e. Contractor/Laboratory Support
 - f. Test dates
 - 5. Costs (A table which shows funding requirements by appropriation per fiscal year for the following items):
 - a. Ranges/Facilities
 - b. Support Equipment
 - c. Ammunition
 - d. POL
 - e. Consumables/Expendables
 - f. Test items
 - g. Training

- h. Contractor Support
 - i. TAS/Command Support
 - j. Total by appropriation per FY
6. Cover letter correspondence reference data

Document Title: Research and Technology Work Unit Summary, DD FORM 1498
Directive: DoD 3200.XX-R-1 (Draft)
Other Authority:
Used by: HQMC, MCDEC, DON, DoD
Comment: Data elements numbers correspond to numbered blocks on the form.

Data Elements

1. Agency Accession
2. Date of Summary
3. Date of Previous Summary
4. Kind of Summary
5. Summary Security
6. Work Security
7. Regrading
8. Distribution Instructions (Release Limitations)
9. Level of Summary
10. Number/Codes
 - a. Program Element
 - b. Project Number
 - c. Task Area Number
 - d. Work Unit Number
11. Title
12. Subject Areas

- 13. Start Date
- 14. Estimated Completion Date
- 15. Funding Agency
- 16. Performance Method
- 17A1 Contract/Grant Effective Date
- 17A2 Contract/Grant Expiration Date
- 17B Contract/Grant Number
- 17C Contract Type
- 17D Contract/Grant Amount
- 17E Kind of Award
- 17F Contract/Grant Cumulative Dollar Total
- 18. Resources Estimate
- 18A Professional Man Years
- 18B Funds
- 19A Responsible DoD Organization Name
- 19B Responsible DoD Organization Address
- 19C Responsible Individual
- 20A Performing Organization Name
- 20B Performing Organization Address
- 20C Principal Investigator
- 20F/GAssociate Investigators
- 21. Military/Civilian Application Code
- 22. Keywords

23. Technical Objective

24. Approach

25. Progress

Document Title: RDT&E Program Review

Directive: MCO P5000.10A, MCO 3900.11B

Other Authority:

Used by: MCDEC for briefing programs at HQMC

Comment: Format changes frequently. Following are typical data elements RDOPPs may be used for financial data.

Data Elements

1. RDT&E Overview (matrix display)
 - a. Mission Area No.
 - b. Mission Area Title
 - c. Number of projects for Mission Area
 - d. FYXX Budget per Mission Area
 - e. Total Budget
2. Mission Area Breakout (matrix display)
 - a. Mission Area Number and Title
 - b. Project Number
 - c. Project Title
 - d. Program Element for each Project
 - e. FYXX Budget for each Project
 - f. REDS for each Project
 - g. Remarks for each project
 - h. Mission Area Total for FYXX Budget
 - i. Mission Area Total for RED

3. Project Breakout

- a. Project Name
- b. Project Number
- c. Program Element No.
- d. Sponsor
- e. Mission Area No.
- f. Objective
- g. Documentation and Status
- h. Completed items list
- j. FYXX Milestones (Timeline)
- k. FYXX Tasks
- i. Subtasks
 - (1) Location and subtask list
 - (2) FYXX Authorized and current budget amounts
- m. PMC Item Nomenclature
- n. PMC Resource Category Number (RCN)
- o. Total items required
- p. Unit Cost
- q. Funding profile by FY (matrix display)
 - (1) RDT&E Funding
 - (2) PMC Pres Budget and Quantity
 - (3) PMC POM and Quantity
 - (4) Remarks

Document Title: Military Interdepartmental Purchase Request (MIPR) DD
Form 448

Directive: DoD INST 4115.1

Other Authority:

Used by: HQMC, PDAs

Comment: Used to transmit funds from HQMC to other Armed
Services for either in-house work or contracted
efforts. Data elements are numbered on the document,
and correspond to the numbers listed below.

Data Elements

1. Page No.
2. FSC
3. Control Symbol No.
4. Date Prepared
5. MIPR Number
6. Amend. NO.
7. To
8. From
9. Interservice Supply Support (Check boxes for
status relative to) Purchase Description
 - a. Item No.
 - b. Description
 - c. Quantity

- d. Unit
- e. Estimated Unit Price
- f. Estimated Total Price
- 10. (Information only, not used for data)
- 11. Grand Total
- 12. Transportation Allotment
- 13. Invoice mailing address
- 14. Funding/Accounting data
 - a. ACFN
 - b. Appropriation
 - c. Limit/Subhead
 - d. Supplemental Accounting Classification
 - e. ACCTG STA DOD AAD
 - f. Amount
- 15. Authorizing Officer
- 16. Signature
- 17. Date

ANNEX 2

LCC MODEL ACQUISITION

ACTIVITY LIST

ACQUISITION ACTIVITIES LIST

list Record #	ACTIVITY	DESCRIPTION
1	AM-001	PROPOSED ACQ STRAT (III & ABOVE)
2	AM-002	INIT WORK DIR PROMUL (ALL PROJ)
3	AM-003	PDA SELECTN (ALL PROJ-MCDEC OR OTHER)
4	AM-004	PDA REQ LTR (IF DESIRED PDA, NONMCDEC)
5	AM-005	PDA ACCEPTANCE (NON MCDEC PDA)
6	AM-006	PDA DESIGNTN (NON MCDEC PDA, WORK DIR)
7	AM-007	PDA DESIGNTN (IF MCDEC PDA, WORK DIR)
8	AM-008	PDA (PM) CHARTER DRAFT (NONMCDEC PDA)
9	AM-009	PDA (PM) CHARTER APPRV (NONMCDEC PDA)
10	AM-010	PROPOSED ACQ STRAT SUB (IV-MCDEC PDA)
11	AM-011	JT SVC MOA DRAFT (NONMCDEC PDA)
12	AM-012	JT SVC MOA APPRV (NONMCDEC PDA)
13	AM-013	ACQ STRAT & COST EST REVS (NONMCDEC PDA)
14	AM-118	INITIAL ISSUE IOC (ALL PROJ)
15	CM-001	CONDUCT TYPE A SPEC SRR
16	CM-010	CONDUCT TYPE B SPEC SDR
17	CM-055	DEVELOP TYPE A SPECIFICATION
18	CM-059	APPROVE TYPE A SPEC (FUNCT BASELINE)
19	CM-060	PREPARE CONFIGURATION MANAGMT PLAN
20	CM-100	DEVELOP TYPE B SPECIFICATION
21	CM-105	APPROVE TYPE B SPEC (ALLOC BSLN)
22	CM-110	DEVELOP CONFIGURATION AUDIT PLAN
23	CM-165	PERFORM FUNCT CONFIGURATION AUDIT
24	CM-175	FCA MINUTES
25	CM-180	FCA AGENDA
26	CM-190	PREPARE CONFIG STATUS ACCOUNT REPORT
27	CM-195	DEVELOP TYPE C SPEC
28	CM-196	DEVELOP TYPE D SPEC
29	CM-197	DEVELOP TYPE E SPEC
30	CM-198	APPROVE C, D, E, SPECS (PRODUCT BSLN)
31	CM-200	PERFORM PHYS CONFIGURATION AUDIT
32	CM-205	PCA AGENDA
33	CM-210	PCA MINUTES
34	CM-220	SUBMIT ENG CHG PROPOSALS (ECP'S)
35	CM-250	CONDUCT PDR
36	CM-300	CONDUCT CDR
37	CS-005	DETERMINE PREL COMPUTER RESOURCES RQMT
38	CS-010	DEVELOP SOFTWARE DEVELOPMENT PLAN
39	CS-015	IDENTIFY SOFTWARE SUPPORT AGENT
40	CS-020	PREPARE PROG PERFORMANCE SPEC
41	CS-025	PREPARE COMPUTER PROGR TEST PLANS
42	CS-026	PREPARE COMPUTER PROGR TEST SPECS
43	CS-027	PREPARE COMPUTER PROGR TEST PROCEDR

44	CS-030	CONDUCT SECURITY RISK ASSESSMENT
45	CS-035	PREPARE PROGRAM DESIGN SPEC
46	CS-040	DEV INTERFACE DESIGN SPECIFICATIONS
47	CS-045	DEVELOP DATA BASE DESIGN DOCUMENT
48	CS-050	DEVELOP SYS OPERATORS MANUAL
49	CS-055	DEVELOP OPERATORS MANUAL
50	CS-056	DEV PROGRAM DESCRIPTION DOCUMENT (PDD)
51	CS-060	PREPARE COMPUTER TEST REPORTS
52	CS-065	REVISE ALL DOCUMENTATION AS REQUIRED
53	CS-070	DEVELOP PROGRAM PACKG DOCUMENT
54	CS-075	CONDUCT/REPORT INDEPENDENT SECURITY TEST
55	CS-076	PREP SOFTWARE PROJECT STATUS REVIEW RPT
56	CS-077	PREP SOFTWARE CONFIGURATION MANGMT PLAN
57	CS-078	PREP SOFTWARE QUALITY ASSURANCE PLAN
58	CS-079	PREPARE SOFTWARE TROUBLE REPORT
59	CS-080	OBTAIN SECURITY ACCREDITATION
60	CS-085	SSA SUPPORT
61	CS-090	REVISE COMPUTER PROG AS REQ'D
62	CT-001	ADV PROC PLAN (APP) DEV & SUB
63	CT-002	APP APPROVED (IF APP REQD)
64	CT-101	IFB SUBMITTED -- SS, RIGID CONTR
65	CT-102	IFB RELEASED --MS, RIGID CONTR
66	CT-103	RFP SUBMITTED -- SS, FLEX CONTR
67	CT-104	RFP RELEASED -- MS, FLEX CONTR
68	CT-105	SOLE SOURCE JUSTIF SUB -- RIGID CONTR
69	CT-106	SOLE SOURCE JUSTIF SUB -- FLEXIBLE CONTR
70	CT-107	PREPROPOSAL CONFERENCE
71	CT-108	CONTRACTOR BIDS SUBMITTED
72	CT-109	SOLE SOURCE REVW BD -- RIGID CONTR
73	CT-110	SOLE SOURCE REVW BD -- FLEXIBLE CONTR
74	CT-111	CONTRACTOR PROPOSAL SUBMITTED
75	CT-112	LOW BID CONTRACTOR SELECTED
76	CT-113	IFB RELEASED -- SS, RIGID CONTR
77	CT-114	RFP RELEASED -- SS, FLEX CONTR
78	CT-115	SOLE SOURCE SELECT BD -- MS, FLEX CONTR
79	CT-116	CONTRACT NEGOTIATIONS MS, FLEX CONTR
80	CT-117	CONTRACTOR PROP SUB -- SS, FLEX CONTR
81	CT-118	CONTRACT NEGOTIATIONS -- SS, FLEX CONTR
82	CT-119	D&V CONTRACT AWARD -- IF D&V PHASE REQD
83	CT-120	D&V CONTRACT AWARD -- MS, RIGID CONTR
84	CT-121	D&V CONTRACT AWARD -- MS, FLEX CONTR
85	CT-201	IFB SUBMITTED -- SS, RIGID CONTR
86	CT-202	IFB RELEASED -- MS, RIGID CONTR
87	CT-203	RFP SUBMITTED -- SS, FLEX CONTR
88	CT-204	RFP RELEASED -- MS, FLEX CONTR
89	CT-205	SOLE SOURCE JUSTIF SUB -- RIGID CONTR

90	CT-206	SOLE SOURCE JUSTIF SUB -- FLEXIBLE CONTR
91	CT-207	PREPROPOSAL CONFERENCE -- MS, FLEX CONTR
92	CT-208	CONTRACTOR BID SUBMITTED MS, RIGID CONTR
93	CT-209	SOLE SOURCE REVW BD -- RIGID CONTR
94	CT-210	SOLE SOURCE REVW BD -- FLEX CONTR
95	CT-211	CONTRACTOR PROPOSAL SUBM MS, FLEX CONTR
96	CT-212	LOW BID CONTRACTOR SEL MS, RIGID CONTR
97	CT-213	IFB RELEASED -- SS, RIGID CONTR
98	CT-214	RFP RELEASED -- SS, FLEX CONTR
99	CT-215	SOLE SOURCE SELECT BD -- MS, FLEX
100	CT-216	CONTRACT NEGOTIATIONS MS, FLEX CONTR
101	CT-217	CONTRACTOR PROP SUB -- SS, FLEX CONTR
102	CT-218	FSD CONTR AWARD -- IF FSD PHASE REQD
103	CT-219	FSD CONTR AWARD -- MS, RIGID CONTR
104	CT-220	FSD CONTR AWARD -- SS, FLEX CONTR
105	CT-221	FSD CONTR AWARD -- MS, FLEX CONTR
106	CT-222	PROD CONTRACT AWARD, IF PROD CONTR REQ
107	CT-301	IFB SUBMITTED -- SS, RIGID CONTR
108	CT-302	IFB RELEASED -- MS, RIGID CONTR
109	CT-303	RFP SUBMITTED -- SS, FLEX CONTR
110	CT-304	RFP RELEASED -- MS, FLEX CONTR
111	CT-305	SOLE SOURCE JUSTIF SUB -- RIGID CONTR
112	CT-306	SOLE SOURCE JUSTIF SUB -- SS, FLEX CONTR
113	CT-307	PREPROPOSAL CONFERENCE -- MS, FLEX CONTR
114	CT-308	CONTRACTOR BIDS SUB MS, RIGID CONTR
115	CT-309	SOLE SOURCE REVW BD -- SS, RIGID CONTR
116	CT-310	SOLE SOURCE REVW BD -- FLEX CONTR
117	CT-311	CONTRACTOR PROPOSAL SUB MS, FLEX CONTR
118	CT-312	LOW BID CONTRACTOR SEL -- MS, RIGID CONTR
119	CT-313	IFB RELEASED -- SS, RIGID CONTR
120	CT-314	RFP RELEASED -- SS, FLEX CONTR
121	CT-315	SOLE SOURCE SELECT BD -- MS, FLEX
122	CT-316	CONTRACT NEGOTIATIONS MS, FLEX CONTR
123	CT-317	CONTRACTOR PROP SUB -- SS, FLEX CONTR
124	CT-318	CONTRACT NEGOTIATIONS SS, FLEX CONTR
125	CT-319	SYS REQ REVIEW -- MS, FLEX CONTR
126	CT-320	MS-I, NDCP & TEMP TO SECNAV ACAT IIS ONLY
127	CT-321	PROD CONTR AWARD -- SS, FLEX CONTR
128	CT-322	PROD CONTR AWARD -- MS, FLEX CONTR
129	D-100	MS-I MC DOCUMENT IDENT - ACAT I
130	D-101	MS-I SCP & MC DOCU PREP - ACAT I ONLY
131	D-102	MS-I DOC REVIEWED HQMC - ACAT I
132	D-103	MS-I MSARC REVIEW - ACAT I
133	D-104	MS-I ADM ISSUED - ACAT I
134	D-105	MS-I SCP & TEMP TO SECNAV
135	D-106	MS-I BRIEF TO OSD - ACAT I ONLY

136	D-107	MS-I SCP & TEMP TO SECDEF - ACAT I ONLY
137	D-108	MS-I DSARC - ACAT I ONLY
138	D-109	SECDEF ISSUES SDDM - ACAT I ONLY
139	D-110	MS-I MC DOUCMENT IDENT - ACAT IIS
140	D-111	MS-I ROC PREP, REVIEWED & SUBMITTED
141	D-112	MS-I NDCP & MC DOCU PREP - ACAT IIS ONLY
142	D-113	MS-I DOC REVIEWED HQMC - ACAT IIS
143	D-114	MS-I MSARC REVIEW - ACAT IIS
144	D-115	MSARC APPROVES ROC
145	D-116	MS-I ADM ISSUED - ACAT IIS
146	D-117	MS-I NDCP & TEMP TO SECNAV - ACAT IIS ON
147	D-118	ROC SUBMITTED TO SECNAV
148	D-119	MS-I DNSARC REVIEW
149	D-120	SECNAV APPROVES ROC
150	D-121	SECNAV ISSUES SNDM - ACAT IIS ONLY
151	D-122	MS-I MC DOCUMENT IDENT - ACAT IIC
152	D-123	MS-I ROC PREP, REVIEWED & SUBMITTED
153	D-124	MS-I MC DOC PREP - ACAT IIC ONLY
154	D-125	MS-I DOC REVIEWED HQMC ACAT IIC
155	D-126	MS-I MSARC REVIEW - ACAT IIC
156	D-127	MS-I ADM ISSUED - ACAT IIC
157	D-128	MSARC APPROVES ROC
158	D-130	MS-I MC DOCUMENT IDENT - ACAT III
159	D-131	MS-I ROC PREP, REVIEWED & SUBMITTED
160	D-132	MS-I MC DOC PREP - ACAT III ONLY
161	D-133	MS-I DOC REVIEWED HQMC - ACAT III
162	D-134	MS-I IPR - ACAT III
163	D-135	IPR APPROVES ROC
164	D-136	MS-I ADM ISSUED - ACAT III
165	D-140	MS-I MC DOCUMENT IDENT - ACAT IV
166	D-141	MS-I ROC PREP, REVIEWED & SUBMITTED
167	D-142	MS-I MC DOCUMENT PREP ACAT IV
168	D-143	MS-I DOC REVIEWED HQMC - ACAT IV
169	D-144	MS-I APS REVIEW - ACAT IV
170	D-145	MS-I ADM ISSUED - ACAT IV
171	D-146	APS APPROVES ROC
172	D-147	MS PLAN MTG OPTIONAL 3-6MO PRIOR TO DSARC
173	D-148	SUBMIT A "FOR COMMENT" SCP OR DCP/IPS OSD
174	D-149	COMMENTS ON DOC TO DOD COMPNT-2MOS PR
175	D-150	MS-I DOC UPDATE TO OSD 3WKS PRIOR
176	D-151	COMPONENTS STAFF BRIEFING TO OSD-3WKS PR
177	D-152	DSARC PREBRIEF BY OSD STAFF 2WKS PRIOR
178	D-153	OSD STAFF RPTS TO DAE, 6WDAYS TO DSARC
179	D-200	MS-II MC DOCUMENT IDENT - ACAT I
180	D-201	MS-II DCP/IPS & MC DOC PREP - ACAT I
181	D-202	MS-II DOC REVJEWED HQMC - ACAT I

182	D-203	MS-II MSARC REVIEW - ACAT I
183	D-204	MS-II ADM ISSUED ACAT I
184	D-205	MS-II DCP/IPS & TEMP TO SECNAV
185	D-206	MS-II BRIEF TO OSD - ACAT I ONLY
186	D-207	MS-II DCP/IPS & TEMP TO SECDEF ACAT I ONLY
187	D-208	MS-II DSARC - ACAT I ONLY
188	D-209	SECDEF ISSUES SDDM - ACAT I ONLY
189	D-210	MS-II MC DOCUMENT IDENT - ACAT IIS
190	D-211	MS-II NDCP & MC DOC PREP - ACAT IIS ONLY
191	D-212	MS-II DOC REVIEWED HQMC - ACAT IIS
192	D-213	MS-II MSARC REVIEW - ACAT IIS
193	D-214	MS-II ADM ISSUED - ACAT IIS
194	D-215	MS-II NDCP & TEMP TO SECNAV ACAT IIS ONLY
195	D-216	MS-II DNSARC
196	D-217	SECNAV ISSUES SNDM - ACAT IIS ONLY
197	D-218	MS PLAN MTG OPTIONAL 3-6MO PRIOR TO DSARC
198	D-219	SUBMIT A "FOR COMMENT" SCP OR DCP/IPS OSD
199	D-220	MS-II MC DOCUMENT IDENT - ACAT IIC
200	D-221	MS-II MC DOC PREP - ACAT IIC ONLY
201	D-222	MS-II DOC REVIEWED HQMC ACAT IIC
202	D-223	MS-II MSARC REVEIW - ACAT IIC
203	D-224	MS-II ADM ISSUED - ACAT IIC
204	D-225	COMMENTS ON DOC TO DOD COMPNT, 2MO PR
205	D-226	MS-II DOC UPDATE TO OSD, 3WKS PRIOR
206	D-227	COMPONENTS STAFF BRIEFING TO OSD-3WKS PR
207	D-228	DSARC PREBRIEF BY OSD STAFF 2WKS PRIOR
208	D-229	OSD STAFF RPTS TO DAE, 6WDAYS TO DSARC
209	D-230	MS-II MC DOCUMENT IDENT - ACAT III
210	D-231	MS-II MC DOC PREP - ACAT III ONLY
211	D-232	MS-II DOC REVIEWED HQMC - ACAT III
212	D-233	MS-II IPR - ACAT III
213	D-234	MS-II ADM ISSUED - ACAT III
214	D-240	MS-II DOCUMENT IDENT - ACAT IV
215	D-241	MS-II MC DOC PREP - ACAT IV ONLY
216	D-242	MS-II DOC REVIEWED HQMC - ACAT IV
217	D-243	MS-II APS REVIEW - ACAT IV
218	D-244	MS-II ADM ISSUED - ACAT IV
219	D-300	MS-III MC DOCUMENT IDENT - ACAT I
220	D-301	MS-III NDCP & MC DOC PREP ACAT I ONLY
221	D-302	MS-III DOC REVIEWED HQMC - ACAT I
222	D-303	MS-III MSARC REVIEW ACAT I
223	D-304	MS-III ADM ISSUED ACAT I
224	D-305	MS-III NDCP & TEMP TO SECNAV
225	D-306	MS-III DNSARC
226	D-307	MS-III BRIEF TO OSD IF REQD ACAT I ONLY
227	D-308	MS-III DCP/IPS & TEMP TO SECDEF ACAT I ONL

228	D-309	MS-III DSARC ACAT I ONLY
229	D-310	SECDEF ISSUES SDDM - ACAT I ONLY
230	D-311	SECNAV ISSUES SNDM
231	D-312	MS PLAN MTG OPTIONAL 3-6MO PRIOR TO DSARC
232	D-313	SUBMT A "FOR COMMENT" SCP OR DCP/IPS OSD
233	D-314	COMMENTS ON DOC TO DOD COMPNT, 2MO PR
234	D-315	MS-III DCP/IPS & MC DOC PREP ACAT I ONLY
235	D-316	MS-III DOC REVIEWED HQMC ACAT I
236	D-317	MS-III MSARC REVIEW ACAT I
237	D-318	MS-III ADM ISSUED ACAT I
238	D-319	MS-III DCP/IPS & TEMP TO SECNAV
239	D-320	MS-III MC DOCUMENT IDENT - ACAT IIS
240	D-321	MS-III DOCUM UPDATE TO OSD 3WKS PRIOR
241	D-322	MS-III NDCP & MC DOC PREP - ACAT IIS ONLY
242	D-323	MS-III DOC REVIEWED HQMC - ACAT IIS
243	D-324	MS-III MSARC REVIEW - ACAT IIS
244	D-325	COMPONENTS STAFF BRIEFING TO OSD-3WKS PR
245	D-326	MS-III ADM ISSUED - ACAT IIS
246	D-327	MS-III NDCP & TEMP TO SECNAV ACAT IIS ONLY
247	D-328	DSARC PREBRIEF BY OSD STAFF 2WKS PRIOR
248	D-329	OSD STAFF RPTS TO DAE, 6WDAYS TO DSARC
249	D-330	SECNAV ISSUES SNDM - ACAT IIS ONLY
250	D-331	MS-III MC DOCUMENT IDENT - ACAT IIC
251	D-332	MS-III MC DOC PREP - ACAT IIC ONLY
252	D-333	MS-III DOC REVIEWED HQMC ACAT IIC
253	D-334	MS-III MSARC REVIEW - ACAT IIC
254	D-335	MS-III ADM ISSUED - ACAT IIC
255	D-336	MS-III MC DOCUMENT IDENT - ACAT III
256	D-337	MS-III MC DOC PREP - ACAT III ONLY
257	D-338	MS-III DOC REVIEWED HQMC - ACAT III
258	D-339	MS-III IPR - ACAT III
259	D-340	MS-III ADM ISSUED - ACAT III
260	D-341	MS-III MC DOCUMENT IDENT - ACAT IV
261	D-342	MS-III MC DOC PREP - ACAT IV
262	D-343	MS-III DOC REVIEWED HQMC ACAT IV
263	D-344	MS-III APS REVIEW - ACAT IV
264	D-345	MS-III ADM ISSUED - ACAT IV
265	D-346	MS-III DNSARC
266	D-P00	MS-0 MC DOCUMENT IDENT ACAT I
267	D-P01	MS-0 JMSNS & MC DOC PREP - ACAT I ONLY
268	D-P02	MS-0 DOC REVIEWED HQMC - ACAT I
269	D-P03	MS-0 MSARC REVIEW ACAT I
270	D-P04	MS-0 ADM ISSUED ACAT I
271	D-P05	MS-0 JMSNS & TEMP TO SECNAV
272	D-P06	MS-0 SECNAV APPROVES POM
273	D-P07	MS-0 JMSNS & TEMP TO SECDEF

274	D-P08	SECDEF APPROVES POM - ACAT I ONLY
275	D-P09	SECDEF ISSUES PDM - ACAT I ONLY
276	D-P10	SECDEF ISSUES SDDM JNT SERV ACAT I
277	D-P11	MS-O MC DOCUMENT IDENT - ACAT IIS
278	D-P12	MS-O JSNS & MC DOC PREP - ACAT IIS ONLY
279	D-P13	MS-O DOC REVIEWED HQMC - ACAT IIS
280	D-P14	MS-O MSARC REVIEW ACAT IIS
281	D-P15	MS-O ADM ISSUED ACAT IIS
282	D-P16	JSNS & TEMP SUBMITTED TO SECNAV
283	D-P17	SECNAV APPROVES POM
284	D-P20	MS-O MC DOCUMENT IDENT - ACAT IIC
285	D-P21	MS-O JSNS & MC DOC PREP - ACAT IIC ONLY
286	D-P22	MS-O DOC REVIEWED HQMC - ACAT IIC
287	D-P23	MS-O MSARC REVIEW ACAT IIC
288	D-P24	MS-O ADM ISSUED ACAT IIC
289	D-P25	MSARC APPROVES POM
290	D-P30	MS-O MC DOCUMENT IDENT - ACAT III
291	D-P31	MS-O JSNS & MC DOC PREP - ACAT III
292	D-P32	MS-O DOC REVIEWED HQMC - ACAT III
293	D-P33	MS-O IPR - ACAT III
294	D-P34	MS-O ADM ISSUED ACAT III
295	D-P35	IPR APPROVES POM SUBMIT
296	D-P40	MS-O MC DOCUMENT IDENT - ACAT IV
297	D-P41	MS-O MC DOC PREP ACAT IV ONLY
298	D-P42	MS-O DOC REVIEWED HQMC - ACAT IV
299	D-P43	MS-O APS REVIEW ACAT IV
300	D-P44	MS-O ADM ISSUED ACAT IV
301	D-P45	APS APPROVES POM SUBMIT
302	END.	
303	ENG-015	DETERMINE DESIGN PROJECTIONS
304	ENG-090	DETERMINE RMA & LOG GOALS/CONSTRAINTS
305	ENG-140	CORRECT DESIGN
306	ENG-195	ANALYZE TEST RESULTS AND ECPS
307	ENG-200	ANALYZE PROD IMPROV PROPOSAL MODIFICATION
308	FAC-001	DETERMINE PRELIMINARY FACILITY RQMTS
309	FAC-005	DETERMINE FAC SUPPORT RQMTS (FSR)
310	FAC-010	PREP BASIC FAC RQMTS LST BFRL NVMC 10915
311	FAC-020	ANALYZE EXISTG ASSETS (FACSO P/OUTS)
312	FAC-030	PREP ACTIVITY FACS PLAN (NAVMC 10801)
313	FAC-040	IDENTIFY FACILITIES PROJECTS
314	FAC-050	SELECT SITES & REQ APPRVL (NAVMC 11069)
315	FAC-060	SBMT SUMM FOR CORRCTN OF FAC DEFIC NMC10
316	FAC-070	PREPARE A/E PLANS
317	FAC-080	PREP PROJECT ENGINEERING DOC (PED)
318	FAC-090	CONSTRUCT FACILITIES & INSTALL EQP
319	FAC-110	MODIFY EXISTING FACILITIES AS REQUIRED

320	FAC-120	MAINTENANCE OF FACILITIES
321	FAC-175	ENSURE SUBMIT OF FACILITY PROJECT DOC
322	FAC-180	UPDATE FACILITIES PLANNING
323	HF&SE-005	PREPARE HUMAN ENGR PROGRAM PLAN
324	HF&SE-010	PREP HUMAN FACTORS ENGR PROGRESS RPT
325	HF&SE-015	PREPARE SYSTEM SAFETY PROGRAM PLAN
326	HF&SE-020	PREPARE SYSTEM HAZARD ANALYSIS REPT
327	HF&SE-025	PREPARE O&S HAZARD ANALYSIS REPT
328	LCC-010	MAKE INITIAL LCC/DTUPC ESTIMATE
329	LCC-015	PREPARE LCC/DTUPC ESTIMATE
330	LCC-020	PREPARE LCC/DTUPC ESTIMATE
331	LM-005	ASSIGN ACG AND APO
332	LM-010	PREPARE LAP PART I
333	LM-015	ESTABLISH ILSMT
334	LM-020	PREPARE ILSP
335	LM-030	PARTICIPATE IN LRG
336	LM-035	PREPARE ILS MGT PLAN
337	LM-040	UPDATE ILSP
338	LM-045	REVIEW FUNCTIONAL PLANS
339	LM-050	PREPARE ILS TEST RQMTS FOR DT/OT 1
340	LM-055	PREPARE LAP (PART II)
341	LM-060	PREPARE ACQUISITION PLAN
342	LM-065	PARTICIPATE IN LRG
343	LM-070	UPDATE ILS INPUT TO MCDCP
344	LM-075	UPDATE ILSP
345	LM-080	PREPARE ILSMT AGENDA
346	LM-085	PREPARE ILSMT MINUTES
347	LM-090	PREP POM FOR PMC FUND 20M BEFORE MSARC3
348	LM-095	PREPARE DRAFT ALO
349	LM-100	PREP ILS TEST REQUIREMENTS FOR DT/OT II
350	LM-105	PREPARE ACQUISITION PLAN
351	LM-110	PARTICIPATE IN LRG
352	LM-115	UPDATE ILS INPUT TO MCDCP
353	LM-120	REVIEW FUNCTIONAL PLANS
354	LM-125	PREP ILS TEST RQMTS FOR 1ST ARTICLE TEST
355	LM-130	PREPARE ILSMT AGENDA
356	LM-131	PREPARE ILSMT MINUTES
357	LM-140	DEVELOP LOGISTICS EVALUATION PLAN
358	LM-145	FINALIZE AND DISTRIBUTE ALO TO USERS
359	LM-150	VALIDATE DEL OF LOGISTIC RESOURCES
360	LM-155	CONDUCT LOGISTICS EVALUATION
361	LSA-001	EARLY LSA STRATEGY (101)
362	LSA-002	UPDATE TASK 101
363	LSA-003	UPDATE TASK 101
364	LSA-004	LSA PLAN (102)
365	LSA-005	UPDATE TASK 102

366	LSA-006	UPDATE TASK 102
367	LSA-007	UPDATE TASK 102
368	LSA-008	PROG/DSN REVIEWS (103)
369	LSA-009	UPDATE TASK 103
370	LSA-010	UPDATE TASK 103
371	LSA-011	UPDATE TASK 103
372	LSA-012	USE STUDY (201)
373	LSA-013	UPDATE TASK 201
374	LSA-014	UPDATE TASK 201
375	LSA-015	UPDATE TASK 201
376	LSA-016	SYSTEM STANDARDIZATION (202)
377	LSA-017	UPDATE TASK 202
378	LSA-018	UPDATE TASK 202
379	LSA-019	UPDATE TASK 202
380	LSA-020	COMPARATIVE ANALYSIS (203)
381	LSA-021	UPDATE TASK 203
382	LSA-022	UPDATE TASK 203
383	LSA-023	UPDATE TASK 203
384	LSA-024	UPDATE TASK 203
385	LSA-025	TECHNOLOGIES OPPORTUNITIES (204)
386	LSA-026	UPDATE TASK 204
387	LSA-027	SUPPORTABILITY FACTORS (205)
388	LSA-028	UPDATE TASK 205
389	LSA-029	UPDATE TASK 205
390	LSA-030	UPDATE TASK 205
391	LSA-031	FUNC. REQUIR. IDENT (301)
392	LSA-032	UPDATE TASK 301
393	LSA-033	UPDATE TASK 301
394	LSA-034	UPDATE TASK 301
395	LSA-035	SUPPORT SYSTEMS ALTERNATIVES (302)
396	LSA-036	UPDATE TASK 302
397	LSA-037	UPDATE TASK 302
398	LSA-038	EVAL OF ALTERNATIVES & TRADE-OFFS (303)
399	LSA-039	UPDATE TASK 303
400	LSA-040	UPDATE TASK 303
401	LSA-041	TASK ANALYSIS (401)
402	LSA-042	UPDATE TASK 401
403	LSA-043	EARLY FIELDING (402)
404	LSA-044	POST PRODUCTION SUPPORT (403)
405	LSA-045	SUPPORTABILITY ASSESSMENT (501)
406	LSA-046	UPDATE TASK 501
407	LSA-047	UPDATE TASK 501
408	LSA-048	UPDATE TASK 501
409	LSA-049	LSAR DATA SHEET A O&M REQUIREMENTS
410	LSA-050	UPDATE LSAR DATA SHEET A
411	LSA-051	UPDATE LSAR DATA SHEET A

412	LSA-052	UPDATE LSAR DATA SHEET A
413	LSA-053	LSAR DATA SHEET B ITEM R&M CHARACTER
414	LSA-054	UPDATE LSAR DATA SHEET B
415	LSA-055	UPDATE LSAR DATA SHEET B
416	LSA-056	UPDATE LSAR DATA SHEET B
417	LSA-057	LSAR DATA SHEET B1 FMEA
418	LSA-058	UPDATE LSAR DATA SHEET B1
419	LSA-059	UPDATE LSAR DATA SHEET B1
420	LSA-060	UPDATE LSAR DATA SHEET B1
421	LSA-061	LSAR DATA SHEET B2 CRIT & MAINT ANAL
422	LSA-062	UPDATE LSAR DATA SHEET B2
423	LSA-063	UPDATE LSAR DATA SHEET B2
424	LSA-064	UPDATE LSAR DATA SHEET B2
425	LSA-065	LSAR DATA SHEET C O&M TASK SUMMARY
426	LSA-066	UPDATE LSAR DATA SHEET C
427	LSA-067	UPDATE LSAR DATA SHEET C
428	LSA-068	UPDATE LSAR DATA SHEET C
429	LSA-069	LSAR DATA SHEET D O&M TASK ANALYSIS
430	LSA-070	UPDATE LSAR DATA SHEET D
431	LSA-071	UPDATE LSAR DATA SHEET D
432	LSA-072	UPDATE LSAR DATA SHEET D
433	LSA-073	LSAR DATA SHEET D1 PERSONL & SUPT REQ.
434	LSA-074	UPDATE LSAR DATA SHEET D1
435	LSA-075	UPDATE LSAR DATA SHEET D1
436	LSA-076	UPDATE LSAR DATA SHEET D1
437	LSA-077	LSAR DATA SHEET E SUPT EQP OR TRNG MAT
438	LSA-078	UPDATE LSAR DATA SHEET E
439	LSA-079	UPDATE LSAR DATA SHEET E
440	LSA-080	UPDATE LSAR DATA SHEET E
441	LSA-081	LSAR DATA SHEET E1 UUT & AUTO PROGRMS
442	LSA-082	UPDATE LSAR DATA SHEET E1
443	LSA-083	UPDATE LSAR DATA SHEET E1
444	LSA-084	UPDATE LSAR DATA SHEET E1
445	LSA-085	LSAR DATA SHEET F FAC DESC & JUSTIF
446	LSA-086	UPDATE LSAR DATA SHEET F
447	LSA-087	UPDATE LSAR DATA SHEET F
448	LSA-088	UPDATE LSAR DATA SHEET F
449	LSA-089	LSAR DATA SHEET G SKILL EVAL & JUSTIF
450	LSA-090	UPDATE LSAR DATA SHEET G
451	LSA-091	UPDATE LSAR DATA SHEET G
452	LSA-092	UPDATE LSAR DATA SHEET G
453	LSA-093	LSAR DATA SHEET H SUPPORT ITEMS IDENT.
454	LSA-094	UPDATE LSAR DATA SHEET H
455	LSA-095	UPDATE LSAR DATA SHEET H
456	LSA-096	UPDATE LSAR DATA SHEET H
457	LSA-097	LSAR DATA SHEET H1 SUPPORT ITEM IDENT.

458	LSA-098	UPDATE LSAR DATA SHEET H1
459	LSA-099	UPDATE LSAR DATA SHEET H1
460	LSA-100	UPDATE LSAR DATA SHEET H1
461	LSA-101	LSAR DATA SHEET H SUPPORT ITEMS IDENT.
462	LSA-102	UPDATE LSAR DATA SHEET H
463	LSA-103	UPDATE LSAR DATA SHEET H
464	LSA-104	UPDATE LSAR DATA SHEET H
465	MAINT-005	FORMULATE INITIAL MAINT CONCEPT
466	MAINT-010	EVALUATE ALTERNATIVE MAINT CONCEPTS
467	MAINT-025	UPDATE MAINTENANCE CONCEPT
468	MAINT-045	DEVELOP PRELIMINARY MAINT PLAN
469	MAINT-060	EVALUATE MAINTENANCE PLAN
470	MAINT-061	PREP LEVEL OF REPAIR (LOR) PROGRAM PLAN
471	MAINT-064	PREPARE LOR ANALYSIS REPORT
472	MAINT-065	PREPARE LOR STATUS REPORT
473	MAINT-066	PREPARE LOR SUMMARY REPORT
474	MAINT-070	DETERMINE DMA REQUIREMENTS
475	MAINT-075	REQUEST DEPOT MAINT NEW STARTS
476	MAINT-080	ASSIGN DMA/DMI
477	MAINT-085	DETERMINE INTERIM MAINT RQMTS
478	MAINT-086	DETERMINE ENGINEERING SERVICES RQMTS
479	MAINT-090	UPDATE MAINTENANCE PLAN
480	MAINT-103	LOGISTIC SUPPORT ANALYSIS REV
481	MAINT-104	ESTABLISH INTERIM MAINT PROGRAM
482	MAINT-105	ESTABLISH MAINTENANCE PROGRAM
483	MAINT-110	FINALIZE MAINTENANCE PLAN
484	MAINT-115	PREPARE LOR STATUS REPORT
485	MAINT-120	UPDATE MAINTENANCE PLAN
486	MAINT-125	PROVIDE DATA TO MIMMS
487	MP-005	PREPARE MTIA
488	MP-010	UPDATE MTIA
489	MP-015	CONDUCT MANPWR PERSONNEL TRADE-OFFS
490	MP-025	PREPARE MANPWR IMPACT ANALYSIS
491	MP-030	CONDUCT MANPWR TRADE-OFF ANALYSES
492	MP-035	PREPARE TABLE OF ORGANIZATN INPUT
493	MP-040	ASSIGN PERSONNEL FOR MAINT DEMO
494	MP-045	UPDATE MOS REQUIREMENTS
495	MP-050	UPDATE TABLE OF ORGANIZATN INPUT
496	MP-055	DETERMINE PERSONNEL AVAILABILITY
497	MP-060	NOTIFY MMOA/MMEA OF PERSONNEL RQMT
498	MP-065	ASSIGN KEY PERSONNEL TO FACTORY TRNG
499	MP-070	ASSIGN INSTRUCTORS TO FACTORY TRNG
500	MP-075	ASSIGN PERSONNEL TO TRNG/OPS UNITS
501	PACK-001	PREPARE PRESERVATION & PACKAGING PLAN
502	PACK-002	PREPARE PRESERVATION & PACKAGING DATA
503	PACK-003	UPDATE PRESERVATION & PLAN

504	PACK-004	UPDATE PRESERVATION & PACKAGING DATA
505	PACK-040	CONSIDER STORAGE/STOWAGE RQMTS
506	PACK-080	DETERMINE STORAGE/STOWAGE RQMTS
507	PACK-090	DETERMINE RE-USABLE CONTAINER RQMT
508	QA-001	PREP QUALITY ASSURANCE PROGRAM PLAN
509	QA-005	INSPECTION SYSTEM PROGRAM PLAN
510	QA-010	PRODUCTION/ACCEPTANCE PROCEDURES
511	QA-015	ENVIRONMENTAL TEST REPORT
512	QA-020	PRODUCTION INSPECTION REPORTS
513	QA-025	FINAL ITEM INSPECTION
514	QA-030	ACCEPTANCE RECORDS
515	QA-035	END ITEM INSPECTION REPORTS
516	RAM-010	IDENTIFY RAM & LOG GOALS/CONSTRAINTS
517	RAM-015	PREPARE RELIABILITY PROGRAM PLAN
518	RAM-020	PREPARE PROGRAM PLAN
519	RAM-023	DEVELOP RELIABILITY MATH MODEL
520	RAM-025	PERFORM FMECA
521	RAM-040	PREPARE MAINTAINABILITY PREDICTION RPT
522	RAM-065	PREPARE RELIABILITY PREDICTION RPT
523	RAM-070	UPDATE FMECA
524	RAM-075	PREPARE RELIABILITY STATUS REPORT
525	RAM-076	PREPARE MAINTAINABILITY STATUS REPORT
526	RAM-077	PREPARE RELIABILITY STATUS REPORT
527	RAM-078	PREPARE MAINTAINABILITY STATUS REPORT
528	RAM-095	PERFORM RELIABILITY DESIGN REVIEW
529	RAM-110	UPDATE FMECA
530	RAM-112	PREPARE RELIABILITY STATUS REPORT
531	RAM-113	PREPARE MAINTAINABILITY STATUS REPORT
532	RAM-120	PREPARE RELIABILITY TEST PLAN
533	RAM-121	PREPARE RELIABILITY TEST PROCEDRS
534	RAM-125	PERFORM/REPORT RELIABILITY TEST & DEMONSTR
535	RAM-126	PREPARE MAINTAINABILITY DEMO PLAN
536	RAM-130	PERFORM/REPORT MAINTAINABILITY DEMONSTR
537	RAM-135	ANALYZE TEST RESULT/FAILURE REPORTS
538	RAM-150	PREPARE RELIABILITY STATUS REPORTS
539	RAM-155	PREPARE MAINTAINABILITY MAINTAINABILITY REPORT
540	RAM-170	PERFORM RELIABILITY DESIGN REVIEW
541	RAM-180	PREPARE RELIABILITY PROD TEST PLAN
542	RAM-185	PERFORM RELIABILITY PROD TEST
543	RAM-190	PREPARE RELIABILITY PROD TEST RPT
544	RAM-195	FAILURE ANALY & CORRECTIVE ACTION REPORT
545	RAM-200	FAILED ITEM ANALYSIS REPORT
546	S&TE-005	DETERMINE PRELIMINARY S&TE RQMTS
547	S&TE-010	DETERMINE S&TE REQUIREMENTS
548	S&TE-011	SUBMIT GROUND SUPPORT EQUIP REC DATA GSE
549	S&TE-015	UPDATE S&TE REQUIREMENTS

550	S&TE-020	TOOL, JIG AND TEST FIXTURE REQUIREMENTS
551	S&TE-021	SUBMIT TOOLS AND TEST EQUIP
552	S&TE-025	ATE REQUIREMENTS
553	S&TE-030	TPS/TRD REQUIREMENTS
554	S&TE-035	GPTE-SPTE REQUIREMENTS
555	S&TE-040	EVALUATE EDM FOR TESTABILITY
556	S&TE-045	UPDATE S&TE REQUIREMENTS
557	S&TE-050	ENSURE ATE AVAILABILITY FOR MAINT DEMO
558	S&TE-055	TOOL, JIG AND TEST FIXTURE REQUIREMENTS
559	S&TE-060	ATE REQUIREMENTS
560	S&TE-065	TPS/TRD REQUIREMENTS
561	S&TE-070	GPTE/SPTE REQUIREMENTS
562	S&TE-075	REVIEW GSERD
563	S&TE-080	DETERMINE SUPPORT EQUIP REQUIREMENTS
564	S&TE-085	DEVELOP CONSOLIDATED BUY LIST
565	S&TE-090	PROCURE AND SHIP S&TE
566	S&TE-091	CROSS REFERENCE TABLES
567	S&TE-092	DIAGNOSTIC FLOW CHARTS
568	S&TE-096	MODIFY S&TE
569	S&TE-100	MASTER TEST PROGRAM SET INDEX
570	S&TE-105	SOURCE & OBJECT PROGRAM LISTING
571	S&TE-110	TEST STRATEGY REPORT
572	SS-005	EVALUATE/ALTER SUPPLY SUPPORT CONCEPTS
573	SS-010	DETERMN PRELIM SUPPLY SUPPORT REQUIREMENT
574	SS-011	SUBM INITL SPARES WKSHEET TO MCLB, ALBANY
575	SS-015	PREPARE PROVISIONING RQMT STATEMENT
576	SS-020	DEVELOP SUPPLY SUPPORT PLAN
577	SS-040	CONDUCT PROVISIONING GUIDANCE CONF
578	SS-041	PREPARE COMMON & BULK ITEM LIST
579	SS-042	PREP PROVISING & OTHER PRE-PROCURMT DATA
580	SS-044	PREPARE NPAR/PROP ADDITIONS APPROVD
581	SS-045	UPDATE SUPPLY SUPPORT PLAN
582	SS-046	PREPARE PROGRAM PARTS SELECTION LIST
583	SS-047	PREP DESIGN CHANGE NOTICES (DCN) (PTD)
584	SS-048	PREP ITEM LOGISTIC DATA RECORDS (ILDR)
585	SS-050	DEVELOP PTD PACKAGES & LISTS
586	SS-055	PREPARE STOCK LIST
587	SS-056	IDENTIFY LONG LEAD ITEMS
588	SS-058	PROCURE LONG LEAD ITEMS
589	SS-059	RECEIVE REVISE PROVISION TECH DOC
590	SS-060	PREP CNTR TECH INFO CODING OF REPLMT PTS
591	SS-061	DEVELOP TECH DATA IDENTIF CHECK-LIST
592	SS-062	PROVIDE TEST DATA FOR NON STANDARD PARTS
593	SS-063	CONDUCT PROVISIONING CONF (QTRLY)
594	SS-064	INITIATE ACTION TO REGISTER USERS
595	SS-065	PROCURE AND SHIP INITIAL SPARES

596	SS-066	RECEIVE SVC MIPR
597	SS-067	SVCS VERIFY W/DLSC THAT SICA CAT ACT
598	SS-068	PROVISIONING ITEMS ORDER REG TO ITTDCD
599	SS-069	PICA PROCESSES INITIATES NISMR
600	SS-070	UPDATE STOCK LIST (AS REQUIRED)
601	SS-071	RECEIVE PROVISIONING ITEM ORDER
602	SS-075	ATTAIN INITIAL SPARES READY FOR ISSUE
603	SS-080	RELEASE INITIAL SPARES TO SMU
604	SS-085	ATTAIN IN-SERVICE DATE
605	SS-090	DETERMINE INTERIM SUPP REQUIREMENTS
606	SS-095	ID SPARES REQUIRED FOR TESTING
607	SS-100	PROCURE & DISTRB SYSTEM SUPPORT PACKAGE
608	SS-105	ESTABLISH INTERIM SUPPLY SUPPORT
609	SS-110	DEVLP/PUBLISH TRANSITION PLAN
610	START.	
611	T-001	TEMP PREPARED (III OR ABOVE)
612	T-002	TEMP APPROVED (III OR ABOVE)
613	T-003	DT/OT-O TPD PUB (IV, IF OT, DT&FMF REQ)
614	T-004	DT-O TPD PUB (III OR ABV IF DT&FMF REQ)
615	T-005	OT-O TPD PUB (III OR ABV IF OT&FMF REQ)
616	T-006	OT-O TST SPT PKG PREP (II & UP, IF OT RE)
617	T-007	OT-O TST SPT PKG APRV (II & UP, IF OT RE)
618	T-008	DT-O DTP DRAFT & APRVD (IF DT REQ-3MOS P)
619	T-009	DT-O DTP DRAFT & APRVD (IV, 3 MOS PR)
620	T-010	OT-O DRAFT & APRVD (III & UP, 3MOS PR)
621	T-011	DT-O TEST CONDUCT (IF DT-O REQD)
622	T-012	OT-O TST ITEM SAF CERT (ALL IF DT NOT REQ)
623	T-013	OT-O TST ITEM SAF CERT (ALL IF DT NOT RE)
624	T-014	DT-O TEST REPORT (IF DT REQD)
625	T-015	OT-O TEST CONDUCT (ALL IF DT/OT REQ)
626	T-016	OT-O TEST CONDUCT (ALL, IF DT NOT REQ)
627	T-017	OT-O TEST REPORT (III OR ABOVE)
628	T-018	OT-O INDEP EVAL RPI (III OR ABOVE)
629	T-020	OT-O TEST RPT (IV, IF OT REQ)
630	T-101	ADM CTROR DEV TST-CDT (IF REQD)
631	T-102	DT/OT-I TPD PUB'D (IF DT, OT & FMF REQD)
632	T-103	DT-I TPD PUB'D (III & UP IF OT & FMF REQD)
633	T-104	OT-I TPD PUB'D (III & UP, IF DT & FMF REQD)
634	T-105	OT-I TST SPT PKG PREP (III & UP IF OT RE)
635	T-106	OT-I TST SPT PKG APRV (III & UP IF OT RE)
636	T-107	DT-I DTP DRAFT & APRVD (IF DT REQ-3MOS P)
637	T-108	OT-I DTP DRAFT & APPVD (IV, 3MOS PRIOR)
638	T-109	OT-I DTP DRAFT & APPVD (III & UP, 3MOS PR)
639	T-110	DT-I TEST CONDUCTED (IF DT REQD)
640	T-111	OT-I TST ITEM SAF CERT (ALL IF OT/DT REQ)
641	T-112	OT-I TST ITEM SAF CERT (ALL, ONLY OT REQ)

642	T-113	DT-I TEST RPT (III & UP IF DT REQ)
643	T-114	OT-I TEST COND (III & UP, OT/DT REQ)
644	T-115	OT-I TEST COND (III & UP, ONLY OT REQ)
645	T-116	OT-I TEST RPT III & UP IF ONLY OT REQ)
646	T-117	OT-I INDEP EVL RPT (III & UP IF ONLY OT REQ)
647	T-118	OT-I TEST RPT (IV, IF OT REQ)
648	T-119	OT-I INDEP EVL RPT (III & UP IF OT/DT REQ)
649	T-201	PREL COMP TST PLAN SUB (ALL W/COMPT)
650	T-202	COMP PROG TST PLAN UPDT (ALL W/COMPT)
651	T-203	COMP PROG TST SPEC DEV (ALL W/COMPT)
652	T-204	COMP PROG TST PLAN & SPEC SUB (ALL W/COMPT)
653	T-205	COMP PROG TST PROC DEV (ALL W/COMPT)
654	T-206	CPCI TST DOCUM APVD (ALL W/COMPT)
655	T-207	HDWR CDT (ALL WITH COMPUTERS)
656	T-208	CPCI DEV TST (ALL W/COMPT, INDEP EVAL?)
657	T-209	CPCI FORM QUAL TST-FQT (ALL W/COMPT, EVAL?)
658	T-210	CPCI TST RPT (ALL W/COMPT, INDEP EVAL?)
659	T-211	EDM CTROR DEV TST-CDT (IF REQD)
660	T-212	DT/OT-II TPD PUB'D (IV, IF FMF REQ)
661	T-213	DT-II TPD PUB (III & UP IF DT& FMF REQ)
662	T-214	OT-II TPD PUB (III & UP IF FMF REQ)
663	T-215	OT-II TST SPT PKG PREP (III OR ABOVE)
664	T-216	OT-II TST SPT PKG APRV (III OR ABOVE)
665	T-217	DT-II DTP DRAFT & APPVD (IF DT REQ, 3MOS)
666	T-218	DT-II DTP DRAFT & APPVD (IV, 3MOS PRIOR)
667	T-219	OT-II DTP DRAFT & APPVD (III & UP, 3M PR)
668	T-220	DT-II TEST CONDUCT (IF DT-II REQ)
669	T-221	OT-II TST ITEM SAF CERT (ALL IF DT REQ)
670	T-222	OT-II TST ITEM SAF CERT (ALL DT NOT REQ)
671	T-223	DT-II TEST REPORT (IF DT-II REQ)
672	T-224	OT-II TEST CONDT (ALL, IF DT REQ)
673	T-225	OT-II TEST COND (ALL, DT NOT REQ)
674	T-226	OT-II TEST RPT (III OR ABOVE)
675	T-227	OT-II INDEP EVAL RPT (III & UP DT NOT REQ)
676	T-228	OT-II TST RPT (III & UP OT/DT REQ)
677	T-229	OT-II TEST REPORT (IV PROGRAM)
678	T-301	OT/DT-III TPD PUB'D (IV-OT, DT & FMF REQ)
679	T-302	DT-III TPD PUB (III & UP IF DT & FMF REQ)
680	T-303	OT-III TPD PUB (III & UP, OT REQ)
681	T-304	OT-III TST SPT PKG PREP (III & UP, OT REQ)
682	T-305	OT-III TST SPT PKG APPVD (III & UP, OT REQ)
683	T-306	DT-III DTP DRAFT & APPVD (DT REQ, 3M PR)
684	T-307	OT-III DTP DRAFT & APRVD (IV, 3M PRIOR)
685	T-308	OT-III DTP DRAFT & APPVD (III & UP, 3MOS)
686	T-309	DT-III TEST CONDUCT (IF DT-III REQD)
687	T-310	OT-III TEST ITEM SAF CERT (ALL IF DT & OT REQ)

688	T-311	OT-III TEST ITEM SAF CERT (ALL, OT REQ)
689	T-312	DT-III TEST RPT (IF DT-III REQ)
690	T-313	OT-III TEST CONDUCT (ALL, DT & OT REQ)
691	T-314	OT-III TEST CONDUCT (ALL, OT REQD ONLY)
692	T-315	OT-III TEST RPT (III & UP OT REQD)
693	T-316	OT-III INDEP EVAL RPT (III & UP OT ONLY REQ)
694	T-317	OT-III INDEP EVAL RPT (III & UP DT/OT REQ)
695	T-318	OT-III TEST RPT (IV, IF OT REQ)
696	T-319	FIRST ARTICLE TEST (AS REQ)
697	TD-006	DEFINE TECH MANUAL CONCEPTS
698	TD-011	PREPARE TECH MANUAL PLAN
699	TD-015	DEVELOP PRELIM TECHNICAL MANUALS
700	TD-020	PERFORM IPR (10%)
701	TD-026	CONTINUE DEVEL OF TECHNICAL MANUALS
702	TD-027	PERFORM IPR (70%)
703	TD-030	VALIDATE PRELIMINARY MANUALS
704	TD-035	VERIFY PRELIMINARY MANUALS
705	TD-036	PREPARE DRAFT REBUILD STD
706	TD-039	PREPARE FINAL TECHNICAL MANUALS
707	TD-041	PREPARE FINAL REBUILD STD
708	TD-045	SUMIT VALIDATED DRAFT TECH MANUALS
709	TD-046	ACCEPT REBUILD STANDARD
710	TD-047	VERIFY TECH MANUALS
711	TD-048	DELIVER PRELIMINARY TECH MANUALS
712	TD-049	TECH MANUALS CAMERA READY COPY
713	TD-050	PRINT AND DISTRIBUTE MANUALS
714	TD-051	PRINT AND DISTRIBUTE REBUILD STD
715	TD-052	FINAL TECHN MANUALS
716	TD-054	REVISE MANUALS AS REQUIRED
717	TD-056	REVISE REBUILD STANDARD
718	TD-057	PREPARE ENGR DRAWINGS & ASSOC LISTS
719	TD-058	PREP IMAGED APPERTURE CARDS
720	TD-059	PREPARE ILLUSTRATIONS
721	TRANS-005	CONDUCT PREL TRANSPORTABLTY ASSESSMENT
722	TRANS-010	DETERMINE PREL FIRST DESTINATIONS
723	TRANS-011	DETERMINE PREL SECOND DESTINATION
724	TRANS-015	CONSIDER SECURITY/HAZARD RQMTS
725	TRANS-020	DETERMINE PREL TRANSPORTATION SUPP RQMTS
726	TRANS-025	CONDUCT TRANSPORTBLTY ASSESSMENT
727	TRANS-030	CONSIDER SPECIAL HANDLING RQMTS
728	TRANS-045	DETERMINE FIRST DESTINATIONS
729	TRANS-046	DETERMINE SECOND DESTINATIONS
730	TRANS-050	CONSIDER SECURITY/HAZARD RQMTS
731	TRANS-055	TEST FOR TRANSPORTBLTY
732	TRANS-065	DETERMINE TRANSPORTATION SUPPORT RQMTS
733	TRANS-070	CONDUCT TRANSPORTBLTY ASSESSMENT

734	TRANS-075	DETERMINE SECURITY/HAZARD RQMTS
735	TRANS-085	DETERMINE SPECIAL HANDLING RQMTS
736	TRANS-100	DETERMINE 1ST AND 2ND DESTINATIONS
737	TRANS-110	DETERMINE TRANSPORTATION SUPPORT RQMTS
738	TRANS-115	TEST FOR TRANSPORTBLTY
739	TRANS-120	CONDUCT FINAL TRANSPORTBLTY ASSESSMENT
740	TRANS-125	OBTAIN TRANSPORTBLTY CERTIFICATION
741	TRANS-135	TEST FOR TRANSPORTBLTY
742	TRANS-140	DETERMINE TRAN RQMTS FOR DMA & DISPOSAL
743	TRNG-005	PREPARE TRNG & TRNG EQUIPMENT PLAN
744	TRNG-010	PREPARE PREL TASK & SKILL ANALYSIS REPT
745	TRNG-015	PERFORM TASK AND MEDIA ANALYSIS
746	TRNG-016	PREP TRAINING COURSES/CURRIC OUTLINES
747	TRNG-020	PERFORM TRNG DEVICE RQMTS ANALYSIS
748	TRNG-025	ID TRAINING SUPPORT REQUIRED
749	TRNG-030	FINALIZE SCOPE OF TRAINING PROGRAM
750	TRNG-035	CONDUCT TRAINING FOR MAINT DEMO
751	TRNG-040	DEVELOP OPERATIONAL TRAINING PLAN
752	TRNG-045	PREPARE AUDIO VISUAL AIDS/MASTER REPROD
753	TRNG-046	PREPARE INSTRUCTOR LESSON GUIDES
754	TRNG-050	PREPARE OJT HANDBOOK
755	TRNG-055	SELECT TRAINING DEVICES/EQUIP
756	TRNG-060	CONDUCT FACTORY TRAINING
757	TRNG-065	EVALUATE TRAINING PROGRAM
758	TRNG-070	PREPARE TURNKEY TRNG PACKAGE
759	TRNG-075	PREPARE TRAINING INPUT PLAN
760	TRNG-080	PREPARE ENGR SPEC TO PROVID TRNG DEVICES
761	TRNG-085	CONDUCT FACTORY TRAINING
762	TRNG-090	CONDUCT INITIAL TRAINING
763	TRNG-095	PROCURE, DEL AND INSTALL TRNG DEVICES
764	TRNG-097	BEGIN FORMAL TRAINING
765	TRNG-100	REVISE TRAINING AS REQUIRED

ANNEX 3
ASPO DATA ELEMENT LIST

Document Title: Concept of Operations (COO)

Directive: MCO P5000.10A

Other Authority:

Used by: HQMC, MCDEC

Comment: This document expands the Required Operational Capability (ROC) to describe how a system would be used within the context of Marine Corps doctrine.

Data Elements

1. Executive Summary
2. Table of Contents
3. Mission
4. Threat
5. General System Description
 - a. Function
 - b. System Components
 - c. Interoperability
6. Operational Concept
 - a. General
 - b. System Employment
 - c. Mission Areas
7. Logistics
 - a. Training

- b. Maintenance
 - c. Supply Support
 - d. Software Support
 - e. Manpower
- 8. Annexes
 - 9. List of Tables
 - 10. List of Figures

Document Title: Manpower Training Impact Analysis (MTIA)
Directive: MCO P5000.10A Systems Acquisition Management Manual
Other Authority:
Used by: HQMC, MCDEC
Comment: This document is an analysis of the personnel and training impact as a result of fielding a new system.

Data Elements

1. Purpose
2. Background
 - a. System Description
 - b. Operator Requirements
 - c. Maintenance Requirements
3. Discussion
 - a. Manpower Requirements
 - b. Training Requirements

Document Title: POM XX Procurement Initiatives Justification Format

Directive:

Other Authority:

Used by: HQMC

Comment: The program submission for a new system or initiative may be included in the POM program year or any of the out-years. This document provides funding profiles, procurement costs, and distribution of O&MMC portion of POM-XX Initiatives.

Data Elements

1. Identification
 - 1) Item Nomenclature
 - 2) Program Sponsor
 - 3) ASPO
 - 4) APO
2. Justification (consists of a narrative description, improved capability impact if not procured, dependence and remarks).
3. Table of Organization (T/O) and Table of Equipment (T/E) Implications
 - a. Constant horizontal column headings
 - 1) Program Element
 - 2) Title
 - 3) Quantity

- 4) T/O #
- 5) T/E #
- b. T/O modified/developed?
- c. T/E modified/developed?
- 4. Manpower Program Change Summary
 - a. Constant horizontal column headings
 - 1) FY XX
 - 2) FY XX
 - 3) FY XX
 - 4) FY XX
 - 5) FY XX
 - b. Left-hand margin, vertical column headings
 - 1) Officer
 - 2) Enlisted
 - 3) Civilian
 - c. Personnel Initiative (copy must be attached)
 - d. Funding Appropriation: O&MMC, O&MMCR, or RDT&E
- 5. Expected Service Life (YRS)
- 6. Documentation
 - a. All new programs except ADP
 - 1) Horizontal column headings
 - (a). Yes
 - (b). No



1.0



1.1



1.25

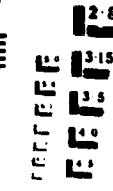

1.4

2.8

3.15

3.5

2.5

2.2

2.0

1.8

1.6

9. Production/Pricing Information

a. Vertical column headings

- 1) Administrative lead time:
- 2) Production lead time:
- 3) Minimum Economical Production Rate per month (Qty):
- 4) 1-8-5 Rate per Month (Qty):
- 5) Maximum Production Rate per month (Qty):
- 6) Lead Service/Contractor:

10. Other Service or Foreign Gov't:

11. Amphibious Lift Requirement

a. Identify square foot and cubic foot requirements per major end items.

- 1) FT²
- 2) FT³

b. Identify square ft and cubic foot requirements per major end item being replaced.

- 1) FT²
- 2) FT³

c. Total Lift Delta (+ or -)

- 1) FT²
- 2) FT³

12. Alternative or Competitive System

13. Facilities

- a. Facilities required to support this program.
- b. Renovation of existing facilities required.
- c. Cost, location, and FY of facilities requirement (relate to MILCON cost in cost data).

14. Approval/Disapproval

15. Sponsor Signature

16. Date

17. Staff Routing

- a. Horizontal column headings
 - 1) Staff
 - 2) Date
 - 3) Approval
 - 4) Disapproval
 - 5) CMTS Attached (yes or no)
- b. Left-hand margin, vertical column headings
 - 1) DC/S for RD&S
 - 2) DC/S for I&L
 - 3) DC/S for R&P

18. Summary Funding Profile (Table) (matrix display)

- a. \$ FYDP (000)
- b. Item Nomenclature

- (c). Date
- 2) Left hand margin vertical column headings
 - (a). ROC
 - (b). Development Plan
 - (c). MSARC I
 - (d). Acquisition Plan
 - (e). LAP Part I
 - (f). MSARC II
 - (g). ILSP
 - (h). LAP Part II
 - (i). MSARC III/IPR III
- b. ROC Projected Manpower Savings:
- c. Automated Information Systems Only (MCO P5231.1)
 - 1) Horizontal column headings
 - (a) Yes
 - (b) No
 - (c) Date
 - 2) Left hand margin, vertical column headings
 - (a) MENS (Milestone)
 - (b) Steering Committee Charter
 - (c) Project Management Plan
 - (d) Requirements Determination Statement
 - (e) Feasibility Study

(f) Configuration Management Plan

(g) System Decision Paper I

(h) System Decision Paper II

(i) System Decision Paper III

(j) Validation and Verification

7. Approval for Service Use Date/ADPE System Test (Vertical Column Headings)

1) Code A

2) Code B

8. Current Development and Test Status

a. Vertical column headings

1) DT&E

2) IOT&E

3) OT&E

4) IOC

b. Horizontal column headings

1) Date compl

c. Vertical column headings

1) EST Date

d. Horizontal column headings

1) Prototype Acq.

2) Prototype Eval.

3) System Test

c. Vertical column headings

(A table which shows funding requirements by appropriation per fiscal year for the following items:

- 1) APPROPRIATION
- 2) PMC
- 3) O&MMC
- 4) O&MMCR
- 5) MPMC
- 6) RPMC
- 7) MCON
- 8) MCSF
- 9) TOTAL
- 10) RDT&E (N) (NON-ADD)

d. Horizontal column headings (Entries in \$000)

1. FY XX
2. FY XX
3. FY XX
4. FY XX
5. FY XX
6. FY XX
7. Total

19. Procurement Cost Program FYDP (\$000) (A table which shows funding requirements per fiscal year for the following items).

a. Left hand margin, vertical column headings

Item Nomenclature

- (1) Quantity
- (2) Unit Cost (1x2)
- (3) Sub Total
- (4) Other SPT Cost
- (5) SP Test Equip
- (6) Gen Test Equip
- (7) MOD KITS
- (8) TRNG Devices
- (9) Sub Total (4+5+6+7+8)
- (10) Total (3+9)
- (11) Initial Spares
- (12) Total (10 +11)

b. Horizontal Column Headings

- 1) FY XX
- 2) FY XX
- 3) FY XX
- 4) FY XX
- 5) FY XX
- 6) FY XX-FY XX
- 7) Total

20. Distribution of O&MC Portion of POM-XX Initiatives (FYDP \$000)

- a. Initiative Number/Title
- b. Date Prepared
- c. Program Sponsor
- d. Action Officer
- e. (A table which shows distribution of funds per fiscal year for the following items).
- f. Left hand margin, vertical column headings
 - 1) General Purpose Forces
 - 2) Land Forces
 - 3) (O&M of New Equipment)
 - 4) (Initial Issue)
 - 5) Naval Forces
 - 6) Tactical Air Forces
 - 7) (O&M of New Equipment)
 - 8) (Initial Issue)
 - 9) Central Supply & Maint
 - 10) Supply Depot Operations
 - 11) Inventory Control Point
 - 12) Transportation of Things - Total
 - 13) (1st Destination)
 - 14) (2nd Destination)

- 15) Other Logistics Support
- 16) Commissaries
- 17) Equipment Maintenance
- 18) (Installation of Mods-5th Echelon)
- 19) Training & Education
- 20) Recruit Training
- 21) Special Skill Training
- 22) Professional Development
- 23) Flight Training
- 24) Training Support
- 25) Officer Acquisition
- 26) Other Personnel Support
- 27) MJROTC
- 28) Off-Duty Education
- 29) Other Personnel Support
- 30) Recruiting & Advertising
- 31) Recruiting
- 32) Advertising
- 33) Administration
- 34) Departmental
- 35) Non-Departmental
- 36) Other Administration
- 37) TOTAL

g. Base Communications

- 1) Forces
- 2) Supply & Maintenance
- 3) Training & Education
- 4) Administration

h. Base Operations

- 1) Real Property Maintenance Act
- 2) Forces
- 3) Supply & Maintenance
- 4) Training & Education
- 5) Administration

i. Other Base Operations

- 1) Forces
- 2) Supply & Maintenance
- 3) Training & Education
- 4) Administration

j. Remarks

k. Mission Forces

- 1) Fuel and Lubricants

- 2) Spare parts (incl. tires, tracks)
- 3) Training (tuition, travel, per diem)
- 4) Publications
 - a. Organizational maintenance
 - b. Contract Maintenance
 - c. Tools
 - d. Mount-out materials
 - e. Comm/elec (wire, batteries, generators)
 - f. Special clothing (helmets, gloves, etc.)
 - g. Transportation of things (TOT):
 - 1) Shipment to units from storage
 - 2) Shipment to and from training
 - 3) Shipment from MC repair activities
 - 4) Shipment to and from non-MC repair
 - 5) Replacement of worn out items
- 5) Depot Maintenance
 - a. 4th and 5th echelon maintenance
- 6) Other Support - Base Operations
 - a. Construction - storage/maintenance
 - b. Utilities
 - c. Security systems
 - d. SMCR administration

e. Collateral equipment

f. ADP support

7. Other Support - Other Activities

a. Recruiting

b. Advertising

c. Individual reserve administration

8. Totals

1. Horizontal column headings

FY XX

FY XX

FY XX

FY XX

FY XX

FY XX - FY XX

m. Functional Sponsor Review

Document Title: CMC Fact Sheet

Directive:

Other Authority:

Used By: CMC

Comment: This document provides current status of C3 RDT&E projects to CMC.

Data Elements

1. Title
2. HQMC Sponsor/Date
3. Purpose
4. Background
5. Intended Role
6. Employment
7. Basic Characteristics
8. Current Status
9. Remarks

Document Title: Mission Area Analysis

Directive: MCO P5000.10A

Other Authority:

Used By: HQMC, MCDEC

Comment: Purpose of this document is to identify deficiencies in existing capabilities or opportunities to establish new capabilities.

Data Elements

1. Title
2. Introduction
 - a. Purpose
 - b. Sources
 - c. Definition and Scope
 - d. Methodology
 - e. Structure
3. Analysis
 - a. Process
 - b. Tasks
 - c. Operational Functions
 - d. Analysis
 - e. Mission Area Tasks
4. Findings

- a. Mission, Organization, and Employment
- b. Current and Future Capability
- 5. Deficiencies and Recommendations
- 6. Conclusions

DEVELOPMENT PLAN

TABLE OF CONTENTS

	Page
Section 1. Needs, Constraints, Thresholds and Program Structure. .	1
1.1 Statement of Need	1
1.2 Program Constraints and/or Thresholds	2
1.3 Resources and Funding	3
1.4 Program Structure	3
 Section 2. Risk Analysis	 5
 Section 3. Strategy to Achieve Objectives and Implementation . . .	 6
3.1 Planning Requirements	6
3.1.1 Objectives and Goals for the Acquisition Effort.	 6
3.1.2 Program Schedule.	6
3.1.3 Program Activities.	9
3.1.4 Acquisition Alternatives.	9
3.1.4.1 Stand Alone Terminals	11
3.1.4.2 Main Frame or Minicomputer.	11
3.1.4.3 Microcomputer Network and Main Frame Connection.	 11

	Page
3.1.5 Plan for Alternative Selection, Timing and Key Selection Decisions	12
3.1.6 Interdependence of System Selected with Other Programs	13
3.1.7 Risk Management	15
3.1.7.1 Technical	15
3.1.7.2 Cost.	15
3.1.7.3 Schedule.	15
3.1.7.4 Logistics	15
3.1.8 Design and Preplanned Product Improvement (P ³ I)	15
3.1.9 Plan for Achieving Reliability in Design and Manufacturing	16
3.1.10 Standardization Considerations.	16
3.1.11 Design-to-Cost and Affordability.	16
3.1.12 Logistics/Personnel/GFE	16
3.1.13 Use of Organizational Assests	16
3.1.14 Mobilization and Deployability Considerations.	17
3.1.15 Financial Strategy.	17
3.1.16 Test Funding.	17
3.1.17 Business Management	17

	Page
3.1.17.1 General Content of Solicitations for Proposals and General Source Selection Criteria.	18
3.1.17.2 Competition	19
3.1.17.3 Use of Technical Data and Rights Thereto.	19
3.1.17.4 Program Thresholds.	20
3.1.17.5 Reliability	20
3.1.18 Audit Trail of Key Decisions.	20

APPENDIX

Appendix A Requirements Statements	A-1
Appendix B Justification for System New Start.	B-1

LIST OF FIGURES

<u>Title</u>	<u>Page</u>
3.1 Contract Time Requirements.	8
3.2 Microcomputer Network Timeline.	10
3.3 Acquisition Coordinating Group Relationships.	14

C3 AUTOMATED PLANNING AND MANAGEMENT INFORMATION SYSTEM

DEVELOPMENT PLAN (DP)

Section 1. Needs, Constraints, Thresholds and Program Structure

1.1 Statement of Need.

Existing decision support to the Acquisition Project Sponsor (APS) is not adequate. Decision making must be augmented with automated analytical management techniques. An improved capability for retrieval of needed programmatic data is required. The ability to establish critical path dependencies, and the sort and query of information to answer critical program management "what if's" is not now available to the APS. Opportunities may be lost and suboptimal decisions made using the limited decision aids now available. The voluminous amount of multi-source data that must be transposed into usable acquisition documentation to support the executive, manager, and action officer levels of decision making exceeds the manpower capabilities of the acquisition staff personnel.

The satisfaction of acquisition information needs is currently being accomplished by manual processing. Some microcomputer equipment available to the Acquisition Coordinating Group (ACG) community has been provided on a piecemeal basis. No systematic plan for automation improvements or data

maintenance has been developed to meet the needs of the APS or the ACG community.

1.2 Program Constraints and/or Thresholds.

The C3 Automated Planning and Management Information System can be developed in accordance with MCO P5231.1 Life Cycle Management for Automated Information Systems (LCM-AIS), or the United States Marine Corps End User Computing Guidelines. Specific constraints are as follows:

1. Allow for operation with a minimal amount of training.
2. Use consumable supplies which are inexpensive and readily available.
3. Equipment will be capable of TEMPEST certification.
4. Be interoperable with other acquisition management information systems in being or in development.
5. Be maintainable at Headquarters Marine Corps and MCDEC.
6. Be capable of hardware and software improvements made possible by advances in End User Computing Equipment (EUCE) technology.

7. Adhere to Federal and Department of Defense (DoD) regulations governing the use and acquisition of software in that Department of Defense and public domain software will be used whenever possible. Commercially available software will be used only when required, and the development of specialized software will be held to an absolute minimum.

1.3 Resources and Funding.

Estimated costs and funding requirements will be developed as part of Phase II, Task 0002, Contract M00027-84-D-003 Marine Corps Studies and Analysis in Command, Control, Communications and Intelligence during June 1985.

1.4 Program Structure

The C³ Automated Planning and Management Information System is designed to assist the APS and the Acquisition Sponsor Project Officer (ASPO), his designated representative, in those efforts necessary to organize and implement program requirements; accumulate cost and schedule data; evaluate and report status; identify cost and schedule variance; perform "what if" analysis; and integrate changes while maintaining the required traceability

to the original baseline. The automated system will consist of two modules and two sub modules. The modules will provide acquisition support from requirement generation through equipment production in the areas of requirement identification, planning, scheduling, controlling, and funding.

Implementation of the system will consist of two phases:

Phase I, Prototype System. A prototype system representing a scaled down version of the final system will be developed using the system specifications developed by the government. The prototype will be used to demonstrate each of the information modules and will validate the architecture to be used in the mature system. The prototype system Local Area Network (LAN) will be developed internal to the C⁴SysDiv.

Phase II System Development. The mature system will build on the results and demonstrated requirements validated in phase I. Increased capabilities in this phase will be the networking of other LANs and connection to additional Marine Corps main frame computers. This connection will facilitate the up loading and down loading of information from C⁴SysDiv microcomputers to main frame, and permit system expansion to other ACG member systems either by direct microcomputer connection or via main frame. Connection to other ACG members will be made in coordination with these functional users based on demonstrated need.

Section 2 Risk Analysis

Risk was evaluated in the areas of schedule, technical development, cost and logistics. No major risks were identified in selecting the acquisition strategy to achieve the basic program objectives. Program implementation will be accomplished in validated phases and existing hardware will be used in the initial phase of development. Follow on development will use DoD or commercial software, and off-the-shelf hardware. The modular design, system flexibility and phased implementation will permit the Marine Corps to develop the program depending on the availability of funding.

Section 3. Strategy to Achieve Objectives and Implementation

3.1 Planning Requirements.

3.1.1 Objectives and Goals for the Acquisition Effort. A C³ Automated Planning and Management Information System will support the acquisition process and provide the capability to coordinate project management functional areas, generate project alternatives, and analyze impacts caused by various management actions. It will utilize decision support methodologies to assist the APS in fulfilling responsibilities to acquire command, control and communications assets for the Marine Corps.

3.1.2. Program Schedule. Guidance provided by the SOW of Task 0002, Contract M00027-84-D-003 for this Development Plan as quoted below required the acquisition of a system which would be implemented by a follow-on contractor in three phases:

"1. Phase I, Prototype System. Development of a scaled-down prototype of the C³ Automated Planning and Management System, shall be according to the specifications furnished in Task 2. Demonstrate that the prototype system works, and that it validates the architecture to be used for the mature system. The prototype shall utilize the hardware environment and the software development language chosen for the mature system.

2. Phase, II System Development. Development, test, and delivery the submodules of the mature system will be incrementally. Provision for necessary documentation for user test and operation, data base construction and system maintenance.

3. Phase III, System Enhancement. Development, test, and delivery of logic for the C³ Automated Planning and Management System linking the submodules with artificial intelligence for trending and forecasting."

The acquisition of the C³ Automated Planning and Management Information System as outlined above would require that the system acquisition follow the program structure identified in MCO P5231.1, Life Cycle Management for Automated Information Systems. This acquisition methodology would require approximately 3 years to implement. A contract must be awarded first for the contractor to develop a prototype system at Milestone I and a second contract after approval to implement at Milestone III. All documentation must be approved prior to contract award. This two step procedure is a requirement of OMB Circular A-109.

Each contract awarded for system design or procurement must follow the standard contracting procedures as shown in Figure 3.1, Contract Time Requirements. It is evident that fifteen months will be required before the follow-on contractor can begin work on the prototype. The time

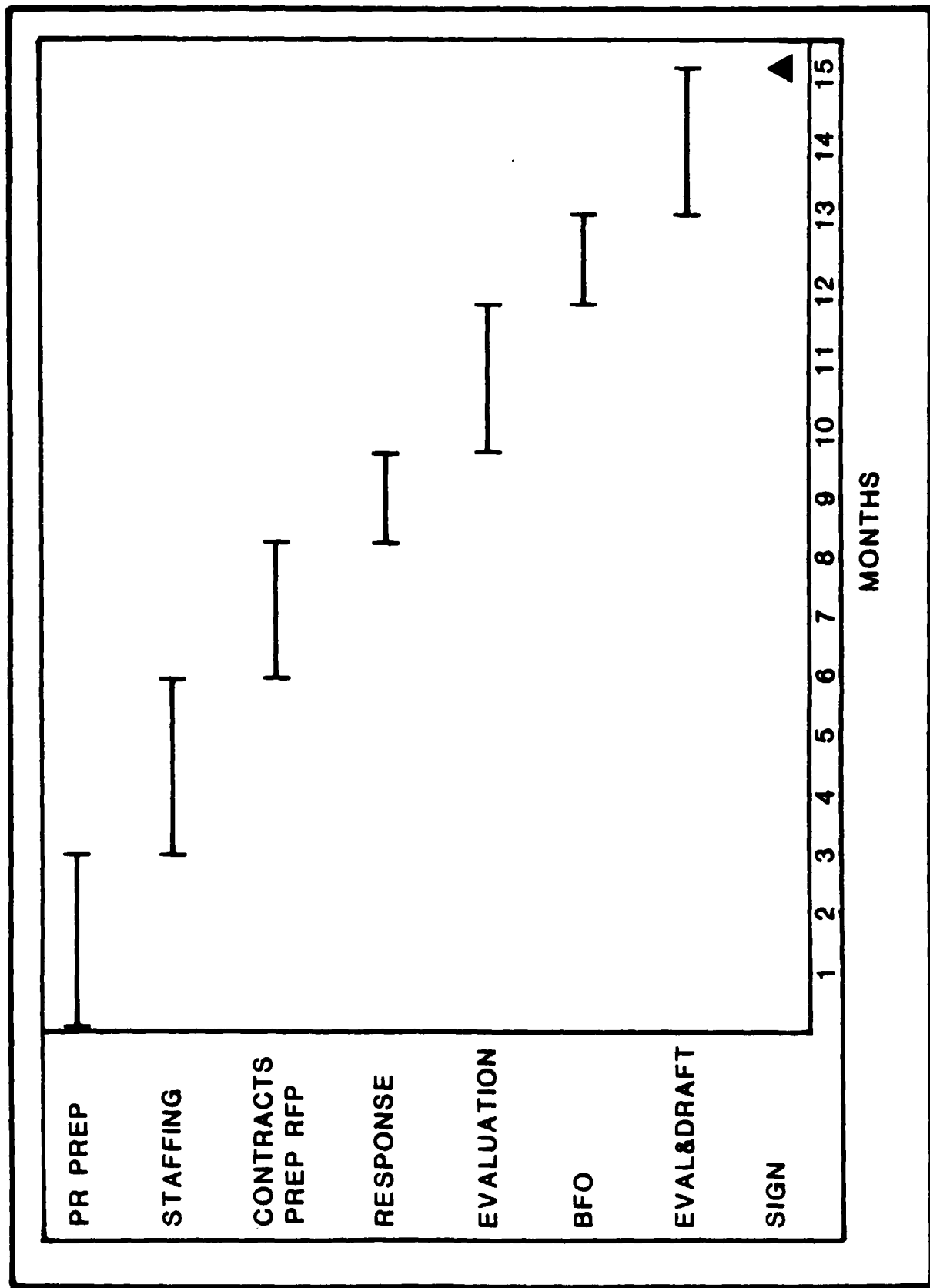

Figure 3.1. Contract Time Requirements

required to produce a functional system can be reduced through the use of current assets and the procurement of additional equipment under the United States Marine Corps End User Computing Guidelines, which streamlines the documentation/justification requirements for end user computers. The acquisition time line for this alternative is shown in Figure 3.2.

3.1.3 Program Activities. Program activities are listed below.

<u>Program Planning</u>	<u>Planned Milestones</u>
Development Plan Approved	May 1985
Prototype System Specification	May 1985
SOW Approved	Jul 1985
RFP Issued	Jan 1986
Contract Award	Apr 1987
Prototype System IOC	Jul 1987

3.1.4 Acquisition Alternatives. To satisfy the APS information requirements three alternate system architectures were considered:

Stand alone terminals (microcomputers).

Main frame or minicomputer (dedicated).

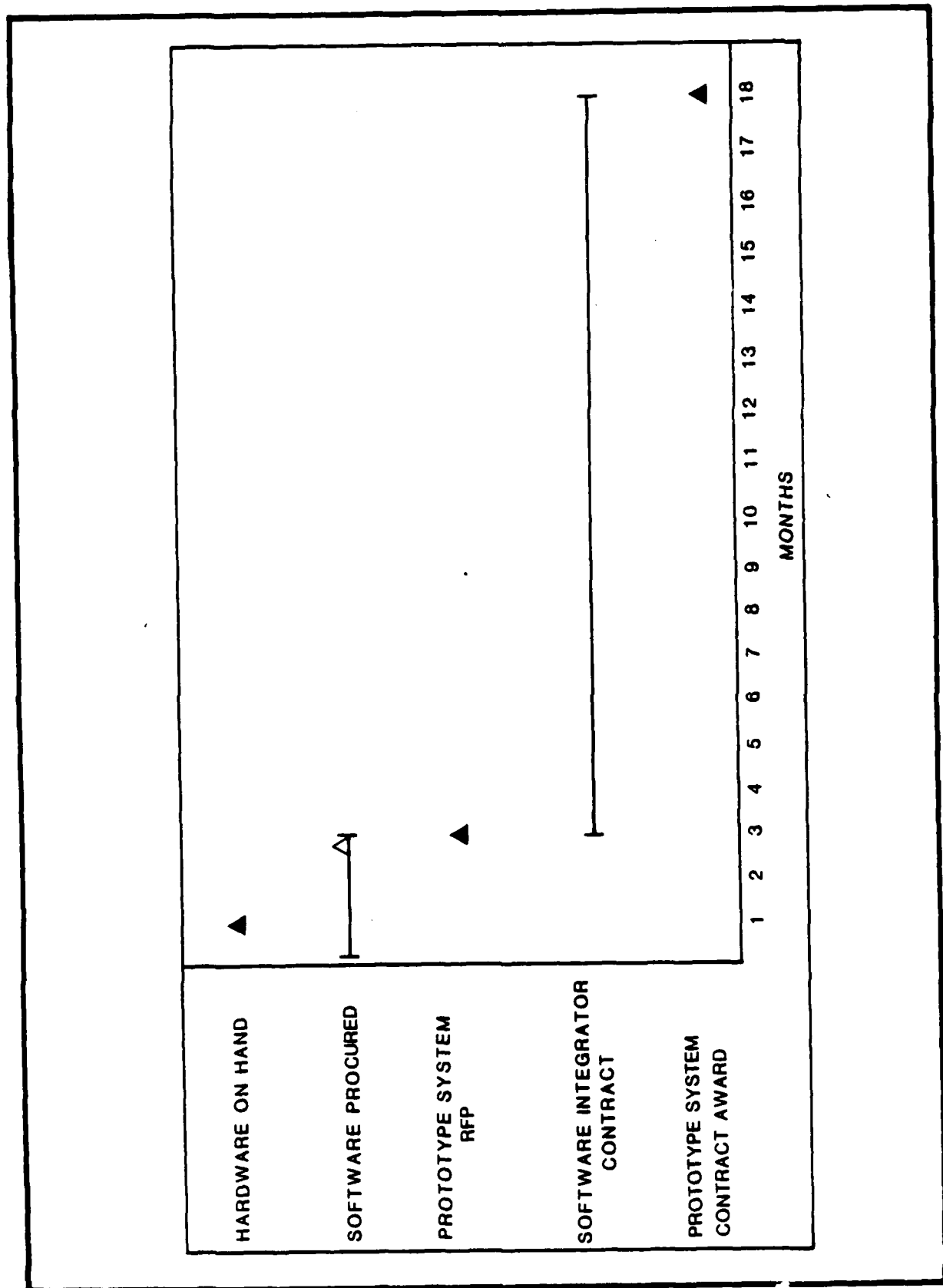

Figure 3.2. Microcomputer Network Timeline

Combination of microcomputer network and main frame connection (shared use).

3.1.4.1 Stand Alone Terminals. The recent technological advances made in end user computing equipment coupled with dramatic price reductions, and the increasing availability of powerful application software, make this option a low risk, easy to implement, inexpensive solution. However, user requirements stated in the interview process indicated that the benefit to be received from the decision support system must exceed the amount of effort expended in data input. The system selected must ultimately link all ACG members to be effective. Stand alone terminals fail to meet the requirements of the user since they are manpower intensive in data entry and provide limited growth potential.

3.1.4.2 Main Frame or Minicomputer. A dedicated main frame or minicomputer provides virtually unlimited computer storage sufficient to implement powerful program management software programs to assist the APS in analytical "what if" analysis. However, this solution is an expensive, time consuming procurement option and possesses excessive capacity for the C3 Automated Planning and Management Information System.

3.1.4.3 Microcomputer Network and Main Frame Connection. This option allows an evolutionary phased development that provides the developer the flexibility to tailor a system to meet exact user requirements. This

approach capitalizes on the strengths of both previously discussed alternatives allowing user friendly off line stand alone terminal work, networking with selected users, and entry into the entire acquisition community via connection to existing Marine Corps main frame computers.

Implementation of this alternative could be accomplished under EUCE guidelines, and an initial operating capability could be provided in the near term.

3.1.5 Plan for Alternative Selection, Timing and Key Selection Decisions. The guidance provided for this Development Plan as stated in paragraph 3.1.2 and supported by the Electrospace Systems, Incorporated Technical Proposal, dated 8 October 1984, states that the acquisition concept should "follow the guidance of OMB Circular A-109 which allows for the development of a prototype system to validate and redefine requirements, prior to the large scale acquisition. It will be a two stage procurement."

Investigation to date, supported by the Hardware/Software Survey and Technical Data Report shows that an approach that proposes a prototype phase using Marine Corps owned hardware is feasible, however, a software system integrator must be acquired to establish data bases and provide system engineering.

Two alternatives exist to accomplish this approach. First, the issuance of a competitive RFP for a systems integrator which would follow the time line depicted in figure 3.2. A second alternative would be to utilize in house resources including on-board support contractors. The former alternative would take 18 months to acquire a system integrator while the latter would take 9 months.

3.1.6 Interdependence of System Selected with Other Programs. The fully mature C³ Automated Planning and Management Information System will support all members of the ACG. Figure 3.3 depicts the interrelationships of the ACG members and outside agencies. It is anticipated that the selected system will take advantage of existing ACG automation initiatives and other functional area data bases. ACG members require information from data bases located at MCCDPA, Quantico, and MCCDPA, Albany. Read only access from data bases at these locations will enable the ASPO to have information to manipulate to assist in the decision making process. The Office Information Network being procured for use by Development Project Officers (DPO) and the Development Coordinator (DC) will provide significant input for the research and development aspect of the acquisition process. Additionally, Headquarters Marine Corps (Code LMA) is developing an acquisition and ILS funding model as part of the Defense Materiel Systems Life Cycle Cost Model contract effort. C⁴, through the POM Working Group,

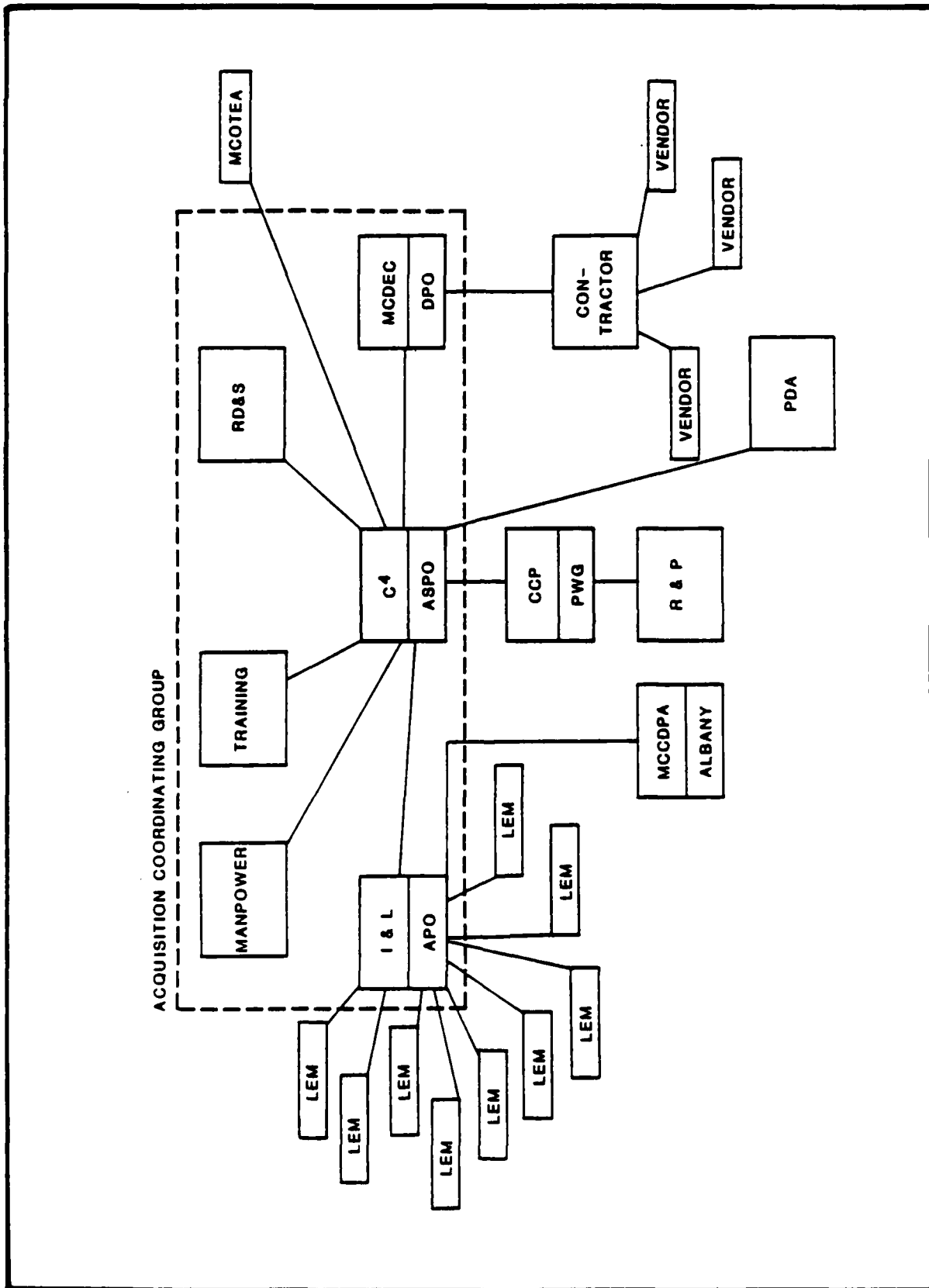

Figure 3.3. Acquisition Coordinating Group Relationships

will be networked to R&P and the Department of the Navy Programming and Budgeting AIS. C⁴ Systems Division will then have access to a data base that will provide current PPBS information.

3.1.7 Risk Management. Total program risk is low as a result of the proposed phased procurement. Specific risk is detailed below.

3.1.7.1 Technical. The only technical risk involved in the system is caused by the possible requirement to modify existing software and obtain access to major Marine Corps data bases associated with Class 1 AIS's, such as LMIS and MIMMS. Technical risk is considered low.

3.1.7.2 Cost. Cost risk has not been determined at this time.

3.1.7.3 Schedule. No schedule risk has been identified.

3.1.7.4 Logistics. No logistics risk has been identified.

3.1.8 Design and Preplanned Product Improvement (P³I) The contractor will utilize existing hardware and software for the prototype C³ Automated Planning and Management Information System. It is not anticipated that the

system will require Preplanned Product Improvement (P3I) during the acquisition cycle, however hardware and software innovations should be investigated as they become available.

3.1.9 Plan for Achieving Reliability in Design and Manufacturing. Utilization of available commercial hardware obviates the requirement to develop a reliability plan.

3.1.10 Standardization Considerations. Equipment must meet or exceed technical standards promulgated under the ADP Standards Program (MCO P5233.1A).

3.1.11 Design to Cost (DTC) and Affordability. The DTC program for the C3 Automated Planning and Management Information System acquisition will be consistent with the provisions of Department of Defense Directive 5000.28.

3.1.12 Logistics/Personnel/GFE. The system will be operated and maintained in HQMC and MCDEC office spaces and will require no unique support. It is anticipated that currently assigned personnel within HQMC and MCDEC will operate the equipment and require only minimal familiarization training to become proficient.

3.1.13 Use of Organizational Assets. Microcomputers currently on hand will be utilized in the prototype system. Software currently on hand,

which does not require modification, will be integrated into the system.

Hardware available within HQMC, Code CCT that can be utilized is:

3 AT&T 6300 PC's and one AT&T 6300 PC on order

3 TEMPEST IBM PC-XT on order

1 IBM PC-XT on order

3.1.14 Mobilization and Deployability Considerations. The C³ Automated Planning and Management Information System will not be affected by mobilization and will not deploy.

3.1.15. Financial Strategy. Following selection of an acquisition alternative, a financial strategy which considers available funds will be developed.

3.1.16 Test Funding. Testing requirements of the C³ Planning and Management Information System will be a contractual responsibility.

3.1.17 Business Management. It is anticipated that a firm fixed price contract will result from the solicitation for the C³ Automated Planning and Management Information System.

3.1.17.1 General Content of Solicitation for Proposals and General Source Selection Criteria. The following evaluation factors will be utilized in the source selection process.

Ability of the offerer to

1. Conform to Federal Processing and Telecommunications Standards
2. Satisfy human factors considerations.
3. Meet hardware/software specifications
4. Meet data exchange and communications requirements.
5. Provide system training/education
6. Provide maintenance service/warranty
7. Provide realistic cost

The cost evaluation for any hardware procured will consist of a detailed evaluation of total lease/rental cost or purchase price plus maintenance costs. The Government reserves the right to award either for the lease/rental items or purchase/maintenance items, whichever is determined to be most advantageous.

The award will be made to the responsible offeror whose offer is most advantageous to the Government based on the evaluation criteria set forth above.

3.1.17.2 Competition. Selection and integration of the system will be done through a competitive contract. Each phase of the acquisition process outlined in Section 1.4 will be based on direct competition.

3.1.17.3 Use of Technical Data and Rights Thereto. The Government, for itself and such others as it deems appropriate, will have unlimited rights in data and computer software specifically developed or generated (i.e., designed and developed) under this Development Plan. Unlimited rights refer to rights to use, duplicate, or disclose software data, in whole or in part, in any manner and for any purpose whatsoever. As a minimum, the Government will have the right to:

- (1) Have unlimited use of such software on computer systems for which or with which it is acquired.
- (2) Use such software with a backup system if the system for which or with which it was acquired is inoperative because of a malfunction, an emergency, change(s) in engineering performance, or change(s) in computer features or models.
- (3) Use such software with the computer at any Government installation to which the computer may be transferred by the Government.
- (4) Copy computer software for safekeeping (archives) or backup purposes.

3.1.17.4 Program Thresholds. Program thresholds will be identified upon selection of an acquisition alternative.

3.1.17.5 Reliability. The use of off the shelf hardware increases the probability of reliable equipment and successful demonstration of the system architecture enhances the probability of program success. Software will be demonstrated to ensure system success. As indicated previously there is low technical risk associated with this system procurement.

3.1.18 Audit Trail of Key Decisions. To be determined.

APPENDIX A
REQUIREMENTS STATEMENT

REQUIREMENTS STATEMENT (RS)

C3 AUTOMATED PLANNING AND MANAGEMENT INFORMATION SYSTEM

SECTION 1 GENERAL

1. Purpose. An automated capability to coordinate acquisition project management functions, generate project alternatives, and analyze impacts caused by various management actions is required to support acquisition project management responsibilities of the Acquisition Program Sponsor (APS), the Acquisition Sponsor Project Officer (ASPO) and other members of the Acquisition Coordinating Group (ACG) chartered by MCO P5000.10A.

2. Point of Contact. The project manager is LTCOL P. Wilder, HQMC/CCTR.

SECTION 2 CURRENT SYSTEM

1. Project References.

- a. MCO P5000.10A, Systems Acquisition Management Manual.
- b. SECNAVINST 5000.1, System Acquisition in the Department of the Navy.
- c. DOD Directive 5000.1, Major System Acquisition
- d. DOD Instruction 5000.2, Major System Acquisition Procedures.
- e. DOD Directive 5000.3, Test and Evaluation

f. MCO 3900.3, Marine Corps Research Development, Test and Evaluation.

g. MCO P4110.1, Acquisition Management Standard Integrated Support Management System.

h. MCO 3900.4, Marine Corps Operational Requirements Documents.

i. MCO P5231.1, Life Cycle Management Automated Information Systems (LCM-AIS)

2. Problem Description. The reference documents prescribe a structured process to manage the acquisition of new systems. Each acquisition project is subject to a series of reviews and decisions at specified milestones during the acquisition cycle. Each review/decision is dependent on successful completion of specific requirements and must be supported with comprehensive and detailed project documentation completed/compiled by ACG members under the direction of the ASPO to support the Director, C⁴ Systems Division.

Each ACG member is responsible for maintenance of project documentation from his functional area that pertains to the acquisition project. ACG members are dependent on the activities of, and data supplied by, other ACG members to accomplish their project management tasks. Without timely exchange of information, ACG members - and especially the ASPO who must coordinate all aspects of the project - are unable to effectively accomplish

their tasks. There is no present automated capability to integrate the varied management actions of the ACG members, ascertain the impact of actions taken by one functional staff activity upon other activities, or effectively maintain the project management information in a manner useful to the ASPO and other ACG members.

3. Existing System

a. Methods/equipment. A combination of manual status tracking and individually developed automation aids using office microcomputers is used to satisfy information processing requirements. Information is exchanged between ACG members by personal contact, written memoranda/reports, or telephonic means. Certain ACG members have limited automated support to assist them in acquisition management tasks; however, since procurement of automation equipment has been accomplished on a piecemeal basis by individual staff agencies, there is virtually no ability to automatically exchange data between staffs. A list of automated equipment now in use follows:

- (1) HQMC/CCT - AT&T 6300 PCs; IBM PC-XT; HP 110; Wang PC
- (2) HQMC/CCP - IBM PC-XT
- (3) HQMC/RD&S - IBM PC
- (4) HQMC/R&P - Programmed to receive terminal for a new DON Programming and Budgeting Automated Information System (AIS)
- (5) MCDEC - AIS now in procurement stages

b. Organizational and Personnel Responsibilities. ACG membership is mandated by MCO P5000.10A. Specific duties of Acquisition Program Sponsors and ACG members from Headquarters Marine Corps staff elements and other agencies are outlined in MCO P5000.10A, chapter 1.

SECTION 3 REQUIRED CAPABILITIES

1. Capability Identification. The following system capabilities are required:

a. Analyze the impacts caused by various programmatic, schedule, and cost changes.

b. Compatibility with existing USMC Class I Automated Information Systems and programmed acquisition management AISs.

c. Ability to store, retrieve, display, manipulate, transfer, and print project management data.

d. Network microcomputers and access main frames.

e. TEMPEST certification.

f. Computer assisted user training.

g. General system capabilities.

(1) Program Management

(2) Report Generation

(3) Spread Sheet

- (4) Word Processing
- (5) Electronic Mail/File Transfer
- (6) Calendar Management
- (7) Data Base Management

2. Organizational Structure. The C³ Automated Planning and Management Information System is designed for use by the APS with input from staff members at Headquarters Marine Corps, MCDEC, and the Principal Development Activity for C⁴ systems.

a. Within Headquarters Marine Corps, the primary system users will be the Director, C⁴ Systems Division, the ASPOs assigned to CCTS and members of the Acquisition Coordinating Group for each C⁴ sponsored acquisition project. ACG membership is prescribed by MCO P5000.10A.

b. At MCDEC, the system will be utilized by Development Project Officers assigned in the C³ Division within the Development Center.

c. A Principal Development Activity (PDA) is assigned for each project. The PDA for Marine Corps C⁴ acquisition projects is normally the Space and Naval Warfare Systems Command (SPAWAR).

3. Interface with Other Systems. Interface with Class I Automated Information Systems is required. This interface would allow automatic transfer of data and eliminate the requirement to manually input data which are resident in existing data bases. A requirement for access into the

LMIS and TMR data bases has been identified; as the system is implemented other requirements may also be identified.

4. Operating Environment. The system will provide an automated capability for the C⁴ APS, ASPOs and members of the ACG for C⁴ sponsored projects. There is no requirement for deployed operation.

5. Communications Requirements. Each user must have the capability to exchange data with every other user. Data exchange will occur on a daily basis between the ASPO and primary ACG members in MCDEC and Headquarters Marine Corps. Data to be exchanged include formatted reports, project documentation, and individual data elements describing project events, cost, or schedule. The volume of data to be exchanged has not yet been determined.

6. Classification. The prototype C³ Automated Planning and Management Information System will not utilize classified information during the demonstration and evaluation of the system. However, it is anticipated that the mature system will process classified and or sensitive data; therefore, consideration must be given during the prototype development for the future application of classified data.

7. Performance Requirements. The system must be capable of meeting the requirements of the ASPO and ACG members in managing acquisition projects. Specific performance criteria for the C³ Automated Planning and Management Information System have not been developed. The hardware and software selected for this system must meet the technical standards prescribed in the USMC Microcomputer Standard (ADP Standards Program), dated 19 Nov 84.

8. Requirements for Backup Capability. There is no requirement for system redundancy to assure 100% operational availability. Duplicate copies of systems software and master data bases should be maintained to prevent catastrophic loss because of system malfunction or inadvertent destruction of the data base.

SECTION 4 VALIDATION OF USER REQUIREMENTS

The user requirements identified in Section 3 were identified as the result of Task 0002 performed under contract M00027-84-D-0033. Each user requirement was defined during a survey of personnel and agencies involved in C⁴ acquisition programs. The system capabilities were identified by survey respondents as being necessary for the accomplishment of their program management tasks as mandated by DOD, DON and HQMC Directives.

APPENDIX B

JUSTIFICATION FOR SYSTEM NEW START

JUSTIFICATION for SYSTEM NEW START (JSNS)

for

A C³ AUTOMATED PLANNING AND MANAGEMENT INFORMATION SYSTEM

SECTION 1. MISSION AREA IDENTIFICATION

1. Mission and Authority

The Director, Command, Control, Communications and Computer (C⁴) Systems Division (DirC⁴SysDiv) provides for the planning, directing and coordinating of staff activities on matters relating to command and control systems, telecommunications and automated information systems. Acting in this capacity, the DirC⁴SysDiv is designated as the Acquisition Program Sponsor (APS) for the acquisition of Marine Corps C⁴ systems and equipment.

2. Current Environment

To assist in carrying out acquisition responsibilities the APS designates an Acquisition Sponsor Project Officer (ASPO) for each acquisition project. The ASPO, acting as the project advocate, chairs the Acquisition Coordinating Group (ACG). This group is composed of Headquarters Marine Corps (HQMC) and Marine Corps Development and Education Command (MCDEC) representatives. The collection, analysis and exchange of information

between members of the ACG is critical to decisions affecting planning, scheduling, monitoring, and controlling of C⁴ projects. Voluminous amounts of multi-source data must be transposed into usable information to support decision making; however, the increasingly complex and expensive C⁴ projects continue to be managed by manual procedures without benefit of automated aids.

SECTION 2 DEFICIENCY

1. Scope

Retrieval and analysis of programmatic, schedule, and cost data is needed to provide decision support for the APS and ACG members. This decision support capability is currently limited because of an inability to process and analyze the large amounts of multi-source data available to support executive, manager, and action officer levels of decision making. The workload involved in transforming this data into usable acquisition project documentation exceeds the manpower capabilities of the office/agencies involved in the acquisition process.

2. Jobs to be Accomplished

An automated capability to coordinate acquisition project management functions, generate alternatives, and analyze impacts caused by various programmatic changes is required. Optimum system features will consist of the following:

- a. Compatibility with existing USMC Class I Automated Information Systems (AIS), and programmed acquisition management AISs.
- b. Ability to plan, schedule, store, retrieve, display, manipulate, and print programmatic, cost, and acquisition schedule data.
- c. Capability to network microcomputers and access main frames.
- d. Utilize commercial off-the-shelf hardware and software.
- e. Be TEMPEST certified
- f. System capabilities
 - (1) Program Management
 - (2) Report Generation
 - (3) Calendar Management
 - (4) Spread Sheet
 - (5) Electronic Mail/File Transfer
 - (6) Word Processing
 - (7) Data Base Management
- g. Computer assisted user training.

SECTION 3 EXISTING AND PROGRAMMED CAPABILITIES

1. Current Capability

In an attempt to satisfy the requirement for improved management information to assist in planning, scheduling, and control of acquisition projects, the C⁴ Systems Division and members of the ACG have procured microcomputers. This procurement which is limited in scope, and implementation has been on a piecemeal basis without a coordinated or systematic plan. HQMC Research, Development and Studies (RD&S) Division, has acquired a microcomputer which is utilized by Development Coordinators to maintain budgeting information and track overall program status. Requirements and Programs (R&P) is planning to install a computer terminal connected to the DON Programming and Budget AIS which will also link members of the POM Working Group. MCDEC is planning to upgrade, expand, and network computer terminals which will provide the Development Project Officers (DPO) an office information network. It is apparent from these actions that a system of microcomputer equipment is emerging which could develop into an interactive system between functional users with connection to Marine Corps main frame computers.

2. Programmed Capability

A C³ Automated Planning and Management Information System will provide accurate and up to date information to the acquisition sponsor. The system will provide an automated capability for decision support necessary to organize and implement project requirements, accumulate cost and schedule data, evaluate and report status, identify cost and schedule variance, perform "what if" analyses, and integrate changes while maintaining required traceability to the original baseline.

3. Impact

As the complexity of new projects increases, so does the amount of data and information needed to properly accomplish related management tasks. There is no present automated capability to integrate the varied management requirements and actions of the ACG members. Exchange of information between ACG members cannot be accomplished on a timely basis by manual means. The program management tasks of each ACG member are dependent on the activities of other members. The lack of immediate access to each member's project related information often results in duplication of effort, dependence upon outdated information, and suboptimal decisions, which adversely affect the acquisition of C⁴ equipment.

SECTION 4. CONSTRAINTS

1. Constraints

- a. All equipment and software utilized for this program must be interoperable with existing Marine Corps Class I AIS's.
- b. The system will be developed in accordance with the Marine Corps Order P5231.1, Life Cycle Management for Automated Information Systems (LCM-AIS) or End User Computer Equipment Guidelines, as appropriate.

2. System Sponsor

It is recommended that the Director, C⁴ Systems Division be appointed as the system sponsor.

END

DTIC

8-86