

AD-A170 640

SQUIRREL NEST BOXES: SECTION 511 US ARMY CORPS OF
ENGINEERS WILDLIFE RESO. (U) ARMY ENGINEER WATERWAYS
EXPERIMENT STATION VICKSBURG MS ENVIR. J M TEAFORD
JUL 86 MES/TR/EL-86-11 F/G 6/6

1/1

UNCLASSIFIED

NL



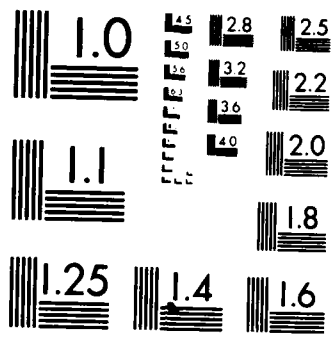

MICROCOPY RESOLUTION TEST CHART
NATIONAL BUREAU OF STANDARDS 1963-A

12

**ENVIRONMENTAL IMPACT
RESEARCH PROGRAM**

TECHNICAL REPORT EL-86-11

SQUIRREL NEST BOXES

Section 5.1.1, US ARMY CORPS OF ENGINEERS
WILDLIFE RESOURCES MANAGEMENT MANUAL

by

James W. Teaford

Environmental Laboratory

DEPARTMENT OF THE ARMY
Waterways Experiment Station, Corps of Engineers
PO Box 631, Vicksburg, Mississippi 39180-0631

DTIC
ELECTE
AUG 5 1986
S B D

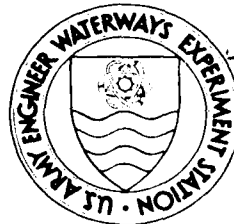

July 1986

Final Report

Approved For Public Release. Distribution Unlimited

Prepared for DEPARTMENT OF THE ARMY
US Army Corps of Engineers
Washington, DC 20314-1000
Under EIRP Work Unit 31631

86 8 5 037



**US Army Corps
of Engineers**

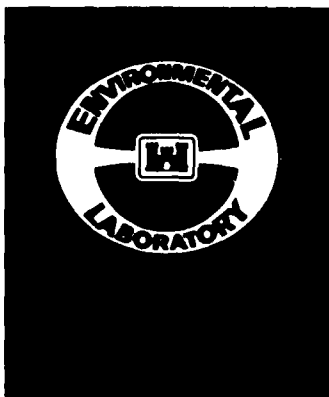

AD-A170 640

DTIC FILE COPY

Destroy this report when no longer needed. Do not return
it to the originator.

The findings in this report are not to be construed as an official
Department of the Army position unless so designated
by other authorized documents.

The contents of this report are not to be used for
advertising, publication, or promotional purposes.
Citation of trade names does not constitute an
official endorsement or approval of the use of
such commercial products.

Unclassified

SECURITY CLASSIFICATION OF THIS PAGE

Form Approved
OMB No 0704-0188
Exp Date Jun 30, 1986

REPORT DOCUMENTATION PAGE

1a REPORT SECURITY CLASSIFICATION Unclassified		1b RESTRICTIVE MARKINGS	
2a SECURITY CLASSIFICATION AUTHORITY		3 DISTRIBUTION / AVAILABILITY OF REPORT Approved for public release; distribution unlimited.	
2b DECLASSIFICATION / DOWNGRADING SCHEDULE		5 MONITORING ORGANIZATION REPORT NUMBER(S)	
4 PERFORMING ORGANIZATION REPORT NUMBER(S) Technical Report EL-86-11		7a NAME OF MONITORING ORGANIZATION	
6a NAME OF PERFORMING ORGANIZATION USAEWES Environmental Laboratory	6b OFFICE SYMBOL (if applicable)	7b ADDRESS (City, State, and ZIP Code)	
6c ADDRESS (City, State, and ZIP Code) PO Box 631 Vicksburg, Mississippi 39180-0631		9 PROCUREMENT INSTRUMENT IDENTIFICATION NUMBER	
8a NAME OF FUNDING / SPONSORING ORGANIZATION US Army Corps of Engineers	8b OFFICE SYMBOL (if applicable)	10. SOURCE OF FUNDING NUMBERS	
8c ADDRESS (City, State, and ZIP Code) Washington, DC 20314-1000		PROGRAM ELEMENT NO.	PROJECT NO.
		TASK NO.	WORK UNIT ACCESSION NO. EIRP 31631
11. TITLE (Include Security Classification) Squirrel Nest Boxes: Section 5.1.1, US Army Corps of Engineers Wildlife Resources Management Manual			
12. PERSONAL AUTHOR(S) Teaford, James, W.			
13a TYPE OF REPORT Final report	13b TIME COVERED FROM _____ TO _____	14 DATE OF REPORT (Year, Month, Day) July 1986	15 PAGE COUNT 19
16 SUPPLEMENTARY NOTATION Available from National Technical Information Service, 5285 Port Royal Road, Springfield, VA 22161.			
17 COSATI CODES		18 SUBJECT TERMS (Continue on reverse if necessary and identify by block number)	
FIELD	GROUP	Squirrel management Nesting structures	
		Squirrel nest boxes (Continued)	
19 ABSTRACT (Continue on reverse if necessary and identify by block number) A management techniques report on squirrel nest boxes is provided as Section 5.1.1 of the US Army Corps of Engineers Wildlife Resources Management Manual. The report was prepared as a guide to assist Corps biologists and resource managers in developing and implementing squirrel management programs on project lands. Topics covered include wooden boxes, rubber tire shelters, placement, personnel and costs, cautions and limitations, and records. The design, construction, and installation of wooden boxes and rubber tire shelters as artificial nesting structures for the eastern gray squirrel (<i>Sciurus carolinensis</i>) and fox squirrel (<i>S. niger</i>) are described. Step-by-step construction procedures are given, specification drawings and lists of materials are provided, and personnel and cost requirements are discussed. Guidelines are provided for placement of nest boxes in suitable squirrel habitat, and methods to ensure maximum use, minimize predation, and reduce vandalism are (Continued)			
20 DISTRIBUTION / AVAILABILITY OF ABSTRACT <input checked="" type="checkbox"/> UNCLASSIFIED/UNLIMITED <input type="checkbox"/> SAME AS RPT <input type="checkbox"/> DTIC USERS		21 ABSTRACT SECURITY CLASSIFICATION Unclassified	
22a NAME OF RESPONSIBLE INDIVIDUAL		22b TELEPHONE (Include Area Code)	22c OFFICE SYMBOL

18. SUBJECT TERMS (Continued).

Artificial nests
Wooden boxes
Rubber tire shelters

Wildlife management
Management practice and techniques

19. ABSTRACT (Continued).

discussed. Recommendations are given for developing a record-keeping system to monitor the success of a squirrel nest box program.

PREFACE

This work was sponsored by the Office, Chief of Engineers (OCE), US Army, as part of the Environmental Impact Research Program (EIRP), Work Unit 31631, entitled Management of Corps Lands for Wildlife Resource Improvement. The Technical Monitors for the study were Dr. John Bushman and Mr. Earl Eiker, OCE, and Mr. Dave Mathis, Water Resources Support Center.

This report was prepared by Mr. James W. Teaford, Wetlands and Terrestrial Habitat Group (WTHG), Environmental Laboratory (EL), US Army Engineer Waterways Experiment Station (WES). Mr. Chester O. Martin, Team Leader, Wildlife Resources Team, WTHG, was principal investigator for the work unit. Review and comments were provided by Mr. Martin and Dr. Wilma A. Mitchell, WTHG, and Dr. Kenneth T. Ridlehuber, Texas A&M University.

The report was prepared under the general supervision of Dr. Hanley K. Smith, Chief, WTHG, EL; Dr. Conrad J. Kirby, Chief, Environmental Resources Division, EL; and Dr. John Harrison, Chief, EL. Dr. Roger T. Saucier, WES, was Program Manager, EIRP. The report was edited by Ms. Jessica S. Ruff of the WES Publications and Graphic Arts Division (PGAD). Drawings were prepared by Mr. John R. Harris, Scientific Illustrations Section, PGAD, under the supervision of Mr. Aubrey W. Stephens, Jr.

At the time of publication, COL Allen F. Grum, USA, was Director of WES, and Dr. Robert W. Whalin was Technical Director.

This report should be cited as follows:

Teaford, James W. 1986. "Squirrel Nest Boxes: Section 5.1.1, US Army Corps of Engineers Wildlife Resources Management Manual," Technical Report EL-86-11, US Army Engineer Waterways Experiment Station, Vicksburg, Miss.



Accession	✓
NI	
DTI	
Unrec	
J	
R	
P	
A	
Dist	
A-1	

NOTE TO READER

This report is designated as Section 5.1.1 in Chapter 5 -- MANAGEMENT PRACTICES AND TECHNIQUES, Part 5.1 -- NESTING AND ROOSTING STRUCTURES, of the US ARMY CORPS OF ENGINEERS WILDLIFE RESOURCES MANAGEMENT MANUAL. Each section of the manual is published as a separate Technical Report but is designed for use as a unit of the manual. For best retrieval, this report should be filed according to section number within Chapter 5.

SQUIRREL NEST BOXES

Section 5.1.1, US ARMY CORPS OF ENGINEERS
WILDLIFE RESOURCES MANAGEMENT MANUAL

WOODEN BOXES	4	PLACEMENT	11
Materials	4	PERSONNEL AND COSTS	11
Construction	5	Materials	11
Installation	7	Construction	12
RUBBER TIRE SHELTERS	8	Installation	12
Materials	8	CAUTIONS AND LIMITATIONS	12
Construction	8	RECORDS	13
Installation	10	LITERATURE CITED	15

Gray squirrels (*Sciurus carolinensis*) and fox squirrels (*S. niger*) use both leaf nests and tree cavities for bedding, nesting, and escape cover, but several investigators have noted the superior cover value of tree cavities (Allen 1942, Brown and Yeager 1945, Nixon et al. 1978). Where the supply of suitable tree cavities is limited, the installation of artificial nesting structures as a management technique has been shown to be effective in increasing the carrying capacity of an area for squirrels (Barkalow and Soots 1965a,b; Flyger and Cooper 1967; Burger 1969; Nixon and Donohoe 1979).

Although the nesting structures discussed here were designed for use by gray squirrels, a number of other animals have used these or similar structures for nesting and roosting. Commonly reported species include the American kestrel (*Falco sparverius*), eastern screech owl (*Otus asio*), northern flicker (*Colaptes auratus*), red-bellied woodpecker (*Melanerpes carolinus*), Carolina wren (*Thryothorus ludovicianus*), opossum (*Didelphis virginiana*), red squirrel (*Tamiasciurus hudsonicus*), southern flying squirrel (*Glaucomys volans*), and mice of the genus *Peromyscus* (Hesselschwerdt 1942, Allen 1943, Nixon and Donohoe 1979, McComb and Noble 1981).

The design, construction, and installation of wooden boxes and rubber tire shelters as artificial nesting structures for gray and fox squirrels are discussed below. Refer to Sanderson (1975) for a discussion of coordinated timber and wildlife management options that have been developed to increase or supplement the supply of natural dens.

WOODEN BOXES

Wooden nest boxes can be made from a variety of materials ranging from surplus ammunition boxes to hollow logs. As long as the materials are durable and the interior dimensions and entry hole approximate those of natural dens, almost any design is suitable. However, the box described by Barkalow and Soots (1965b) is recommended because of its durability and proven acceptance by gray squirrels.

Wooden nest boxes should be constructed of baldcypress heartwood (generally referred to as heart cypress), redwood, western redcedar, incense cedar, Port-Orford cedar, or pressure-treated pine for durability. The sloping roof with an overhang on all sides and hardware cloth floor are designed to reduce the problem of decay resulting from water seeping into or standing in the boxes. The estimated life for heart cypress or treated pine boxes is from 15 to 25 years, whereas an untreated pine box will last only 3 to 5 years.

Materials

The materials needed and the dimensions of each section, after Barkalow and Soots (1965b) and Fields (undated), are given below.

Lumber. Heart cypress, redwood, cedar, or pressure-treated pine; finished dimensions are 1 by 10 in.; approximately 8 lin ft required.

Front. 9-1/4 × 18-1/2 in.; bottom cut square; top beveled 10 deg from back to front.

Back. 9-1/4 × 20 in.; bottom cut square; top beveled 10 deg from back to front.

Entrance side. 7 in. wide; bottom cut square; top angled, 19-3/4 in. long on the back and 18-1/2 in. long on the front; 2-1/2-in.-diam circular opening with the center located 3 in. from the back and 16-1/4 in. from the bottom.

Side. 7 in. wide; bottom cut square; top angled, 19-3/4 in. long on the back and 18-1/2 in. long on the front.

Roof. 10 × 12 in.; cleats 1 × 2 × 6-3/4 in.; front edges of cleats located 1-1/2 in. from long side of roof, outside edges of cleats located 2-1/2 in. from and parallel to short sides of roof; to help minimize warp, the wood used for the roof should be cut from 1- × 10-in. stock (finished dimensions) such that the cleats may be fastened at right angles to the grain; cleats should be located such that they provide a snug fit and prevent shifting of the roof; the roof should overhang the front and back about 3/8 to 1/2 in. and should overhang the sides about 1-3/8 in.

Batten. 1 × 2 × 21-1/2 in.; cut a slot 1/4 in. wide and 1 in. long in center of one end.

Hanger. 20-ga galvanized sheet metal, 2 × 8 in.; drill "keyhole" large enough to fit over 40-penny nailhead near one end; drill 5 nail holes to fit shaft of 6-penny nails near other end.

Floor. 8- × 8-in. square of 1/2- × 1/2-in.-mesh hardware cloth (14-ga iron wire galvanized after welding); bend each side 1/2 in. from margin at right angles, to form 7- × 7- × 1/2-in. "pan."

Wire. No. 10 solid, polyethylene-covered THW conductor, or similar solid core, flexible plastic-covered wire to steady box when mounted in tree.

Hardware. Five 6-penny common galvanized nails to attach batten to box; eleven 6-penny galvanized box nails (5 to attach hanger to batten, 6 to attach cleats to roof); fourteen 8-penny galvanized box nails (12 for box construction, 2 to pin roof to box); two 40-penny aluminum gutter nails; eight 3/4-in. fencing staples to attach hardware cloth bottom to box.

Equipment. Power tools: radial arm or table saw, drill press or portable electric drill, 2-1/2-in. circular hole saw. Lightweight 30-ft extension ladder. Hand tools: hammer, measuring tape, wire clippers.

Construction

Cut the wood to the dimensions given (Fig. 1) and assemble the front, back, and sides as shown in Figure 2. Install the hardware cloth floor so that the wire edges point downward and are even with the lower box edges; staple into place.

Fasten the hanger to the batten using five 6-penny galvanized box nails, and bend the nail ends across the grain of the batten. Attach the batten (with hanger) to the back of the box by driving five 6-penny common galvanized nails through the batten and well into, but not through, the back of the box.

Nail the cleats to the inside of the roof using six 6-penny galvanized box nails. Set the roof in place and drill 1 hole through the top center of each side extending through the roof cleat. Insert two 8-penny galvanized box nails through the holes to secure the roof to the box. Stencil an identification number on the front of each box prior to installation.

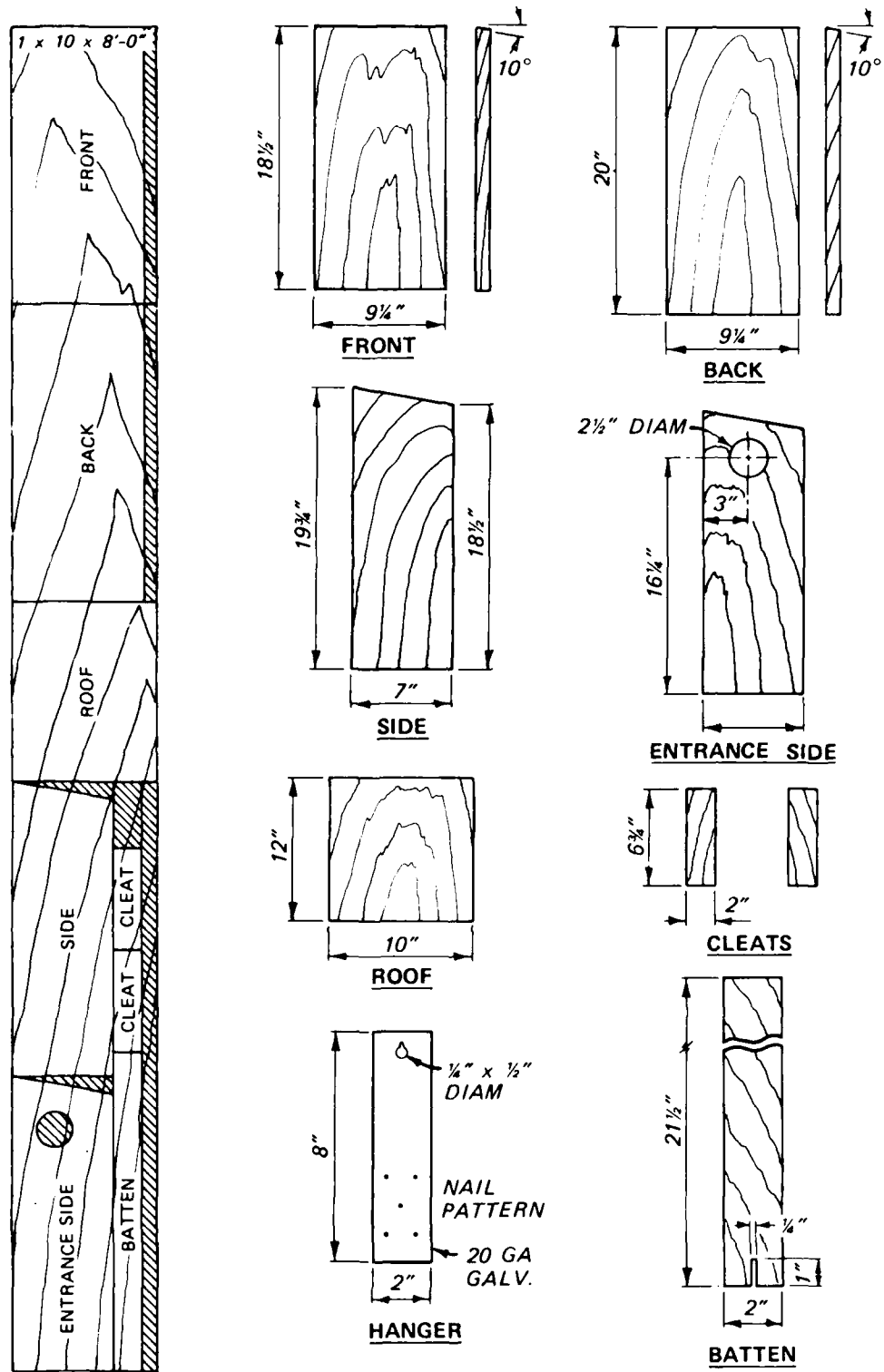

Figure 1. Construction details for a wooden nest box for gray and fox squirrels (after Barkalow and Soots 1965b)

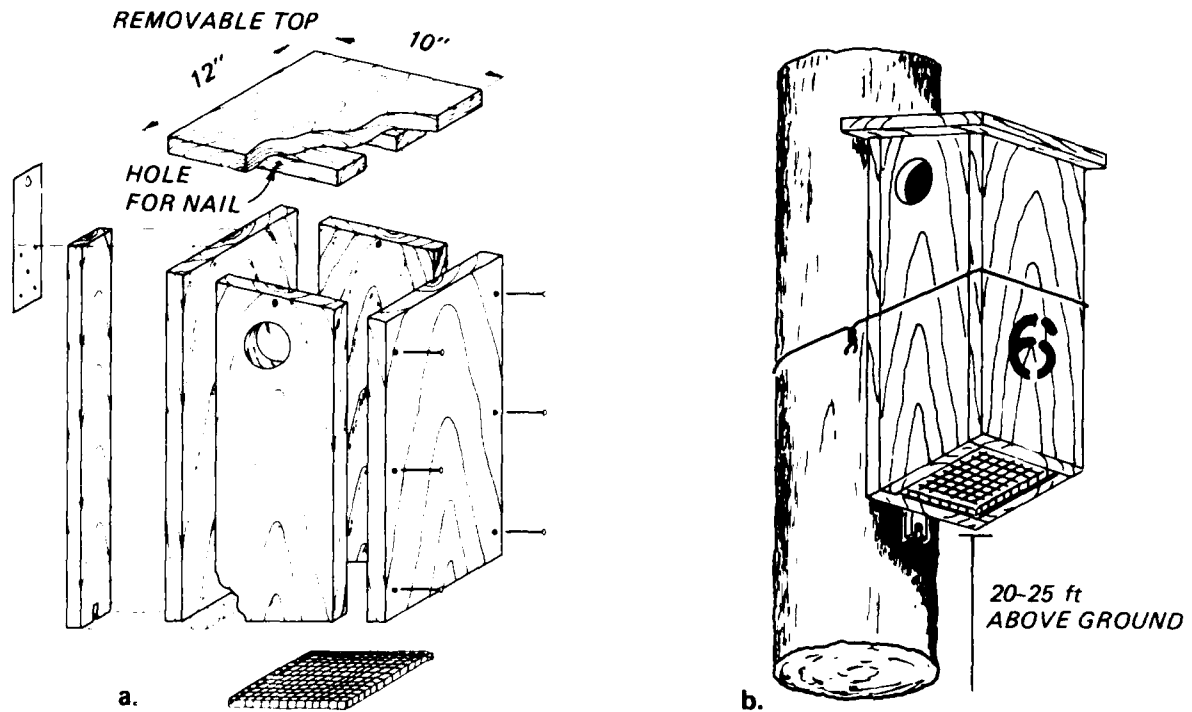

Figure 2. Assembly and installation details for a wooden nest box for squirrels (after Barkalow and Soots 1965b)

Installation

Place a 1-in. layer of dry leaves on the wire floor and mount the box 20 to 25 ft above the ground on the trunk of a tree. Drive one 40-penny non-ferrous nail into the tree and suspend the box by the metal hanger. Drive the second nail through the slot in the batten so that the nail helps to support the weight of the box. Leave a 1- to 2-in. clearance between the nailheads and the top and bottom of the batten strip to allow for tree growth, and check to ensure that the box can be lifted from the supporting nails. Pull the wire taut around the box and the tree trunk and twist the ends together (Fig. 2). The wire should be tight enough to prevent the box from moving as a result of wind action, but loose enough to untwist as the tree grows.

RUBBER TIRE SHELTERS

The Maryland Game and Inland Fish Commission (undated) developed a design that uses one-half of a rubber automobile tire to make a durable, weatherproof squirrel "box." These boxes have been accepted by squirrels (Burger 1969), and they are relatively inexpensive and resistant to damage from vandalism.

Materials

The material and equipment needed to build and install rubber tire shelters are given below:

Box. One 14- to 16-in. automobile tire (1 tire will make 2 boxes). Steel-belted radial tires are not recommended.

Hanger. Eighteen inches of 3/8-in. hot-rolled steel rod. Cold-rolled steel is not recommended because of expense.

Nails. Six 2-in. galvanized roofing nails.

Washers. Seven roofing caps (6 for the nails and 1 for the hanger).

Equipment. Carpet knife, electric jigsaw with knife-edge blades, electric drill with bits, pliers, cord with weight, rope, and metal tubing.

Construction

Remove both beads and cut the tire in half (Fig. 3a). A modified hacksaw blade or a linoleum or carpet knife may be used if only a few tires are to be cut. One should exercise caution when cutting the tires with a carpet knife to prevent slips due to hand and wrist fatigue. If a large number of tires are to be cut, an electric jigsaw fitted with a knife-edge blade may prove handy. Use an appropriately sized drill bit to make a start hole for the jigsaw blade. The knife-edge blades have a tendency to overheat and break, and one should plan on replacing blades after cutting 5 to 10 tires.

Make the cuts and drill the holes in each tire half as shown in Figure 3b. A carpet knife may give better control for making these small cuts. Bend the lower end up and inside the upper end, match the appropriate holes, and fasten the sides together using the roofing nails (Fig. 3c). If there are problems in matching the sides, fold the tire and use the outer holes as guides to mark the inner holes. Fasten holes A to A' and a to a' such that the upper side overlaps the lower side to keep rain out (Fig. 3d). Drill the hole for the hanger such that the entrance will tilt slightly downward to exclude rain, and drill four or five 3/8- to 1/2-in. holes in the bottom of

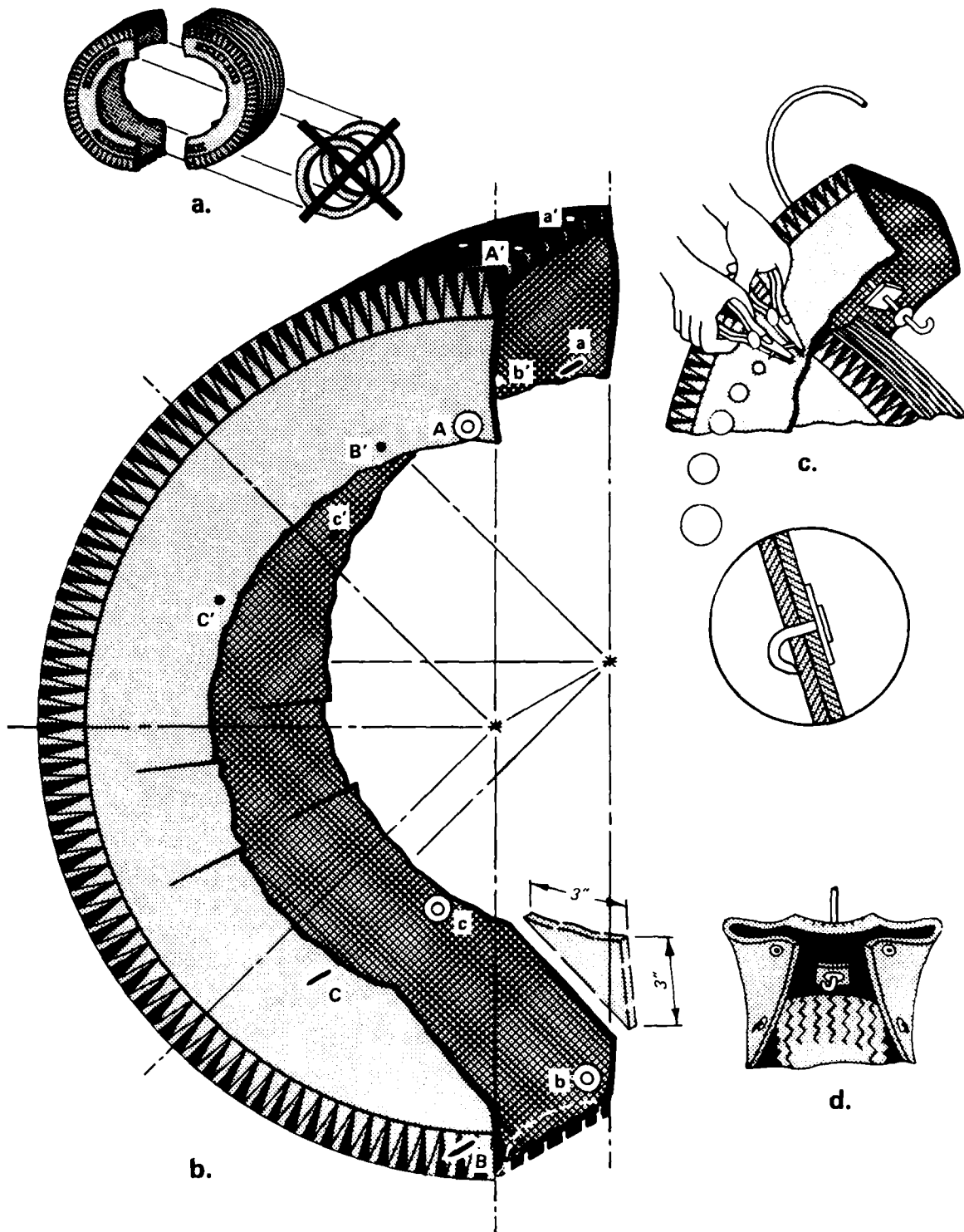

Figure 3. Construction details for a rubber tire shelter showing (a) removal of beads, (b) tire half with cuts and drill holes, (c) sides fastened together with roofing nails, and (d) overlap of sides and position of hanger (after Maryland Game and Inland Fish Commission, undated; Mosby, undated)

the box for drainage. Bend one end of the hanger rod into a tight loop or crimp and slide a roofing cap, followed by a 2- x 2-in. square of rubber, down to this crimp (Fig. 3c); this will help prevent the hanger from pulling through the top (Fig. 3d). Insert the rod through the top of the shelter and bend it to form an open "loop" to fit over a tree limb. An identification number should be stenciled on the front and back of the shelter.

Installation

Use a ladder, rope, or sectional pole and suspend the rubber tire box from a tree limb. Climbing the tree without a support is unsafe and is not recommended. The rope method (Mosby, undated) is described below. Attach a weight (such as a 3- to 6-oz fishing sinker) to a cord and throw the weight over a sound tree limb. Lower the weight to the ground and remove it from the cord. Crimp one half of a 6- to 8-in. piece of metal tubing to one end of a rope; attach the other end of the rope to the cord and pull it over the limb and to the ground. Secure the hanger to the metal tubing as loosely as possible so the rope can be easily freed, and hoist the box up to the limb. When the box is within 5 to 8 ft of the limb, speed up the ascent (but do not jerk) to provide enough momentum for the tubing and hanger to slide over the limb. When the box is hanging properly from the limb, check to ensure that no one is in a position to be injured by the falling metal tube, and shake or jerk the tubing free from the hanger (Fig. 4).

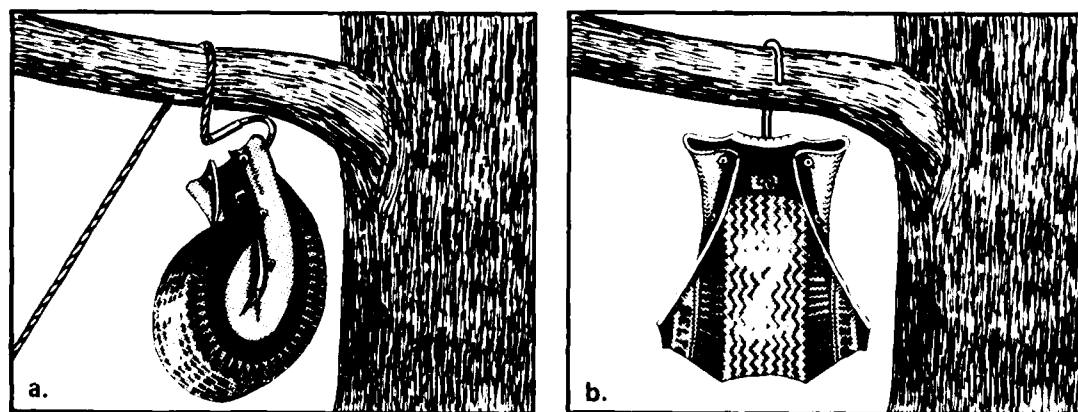

Figure 4. Installation of rubber tire shelters using the rope method (after Mosby, undated)

PLACEMENT

Squirrel nest boxes can be effective when placed in a variety of settings, from hedgerows (Hesselschwerdt 1942) and woodlots (Allen 1943) to extensive forest stands (Barkalow and Soots 1965a). Nest boxes can enable squirrels to use immature poletimber hardwood stands (8- to 12-in. dbh) where adequate food supplies are present but where natural den cavities are lacking (Burger 1969, Nixon and Donohoe 1979). Even-aged oak-hickory stands should be producing hard mast before being considered for nest boxes; even-aged stands 30 to 60 years old are prime candidates, and squirrel populations can benefit significantly from the addition of nest boxes (Nixon and Donohoe 1979). Squirrel populations in mature mixed hardwood-pine stands with adequate food supplies may also show significant increases when the existing supplies of natural dens are supplemented with nest boxes (Barkalow and Soots 1965a). While young poletimber stands and older stands under intensive forest management may show the most net benefit, nest boxes can also be effective in undisturbed mature stands.

One nest box per 2 to 4 acres should be considered the minimum to provide long-term benefits for a squirrel population, and a maximum of 3 to 6 nest boxes per acre may be installed where squirrel management commands a high priority (Sanderson 1975, Nixon and Donohoe 1979). In most cases, however, one nest box per acre appears to be a reasonable goal where squirrels are considered a target species (Barkalow and Soots 1965a).

For aesthetic reasons, the use of rubber tire shelters should be confined to those areas where visitation by the general public is low. In high-visitation areas, i.e. picnic areas, campgrounds, and trails, wooden nest boxes will blend more closely with the natural setting.

PERSONNEL AND COSTS

Materials

Approximately 6.5 bd ft of lumber will be required per wooden box if the various pieces are ripped from 1- x 10-in.-finished dimension lumber. Assuming a breakage rate of about 10%, approximately 725 bd ft of lumber will be

required per 100 boxes. Each box will require 64 sq in. of 1/2- x 1/2-in.-mesh hardware cloth, or approximately 23 to 25 lin ft of a 24-in.-wide roll per 100 boxes. Approximately 3-1/2 lb of 6-penny common galvanized nails, 5-1/2 lb of 6-penny galvanized box nails, 11 lb of 8-penny galvanized box nails, 1-1/2 lb of 3/4-in. fencing staples, and 220 40-penny nonferrous nails will be required per 100 boxes.

Fifty automobile tires, 150 ft of 3/8-in. hot-rolled steel rod, 3 lb of 2-in. galvanized roofing nails, and 1 lb of roofing caps are needed per 100 rubber tire shelters.

Construction

An estimate of 0.8 to 1.6 man-hours per completed squirrel box is reasonable when the time required for gathering materials, making measurements, cutting and drilling, and construction and cleanup is considered. This is equivalent to approximately 10 to 20 man-days per 100 completed boxes.

Installation

Sanderson (1975) reported an estimate by C. M. Nixon, Illinois National History Survey, that a 2-person crew could install up to 5 wooden nest boxes per hour where the terrain was gentle and the distance between boxes was short. This translates to an estimate of 0.4 man-hour per installed box, or 5 man-days per 100 installed boxes. Sanderson (1975) estimated that a 2-person crew, working separately, could install 6 to 8 rubber tire shelters per hour. This gives a range of 0.25 to 0.33 man-hour per installed box or 3 to 4 man-days for 100 installed boxes. However, considering access, movement time, tree inspection and limb selection, recording of information, and actual installation (especially using the rope), a more conservative estimate would range up to 1 man-hour per installed box, or 12 man-days per 100 installed boxes.

CAUTIONS AND LIMITATIONS

Several features have been incorporated into the wooden box design to help minimize predation (Barkalow and Soots 1965b). The 2-1/2-in. circular opening apparently excludes opossums, whereas a 2-1/2-in. square opening does not; furthermore, the opening diameter is small enough to prevent raccoons (*Procyon lotor*) from entering. The 14-in. depth of the box below the bottom of the entrance hole should prevent raccoons and opossums from reaching

squirrels in the nest, and the 1/2- × 1/2-in. mesh of the hardware cloth is small enough to prevent raccoons and other predators from reaching the nest from below. The 14-ga welded iron wire is strong enough to prevent raccoons from forcing the strands apart, while lighter gauges of woven wire apparently are not.

To ensure maximum use and to minimize vandalism, nest boxes should be placed as high as possible (20 to 25 ft for wooden boxes, 20 to 40 ft for rubber tire shelters), and they should be placed in trees that do not contain existing cavities (Lonnie P. Hansen, Illinois National Historical Survey, pers. commun., September 1981). When using the rope method to install rubber tire shelters, select sound limbs that are inclined only slightly to moderately above the horizontal to lessen the chance that the rope will bind in the crotch between the limb and the bole. Boxes nailed to trees having commercial value should be placed above the first log (i.e., at least 20 ft high) to minimize the reduction in timber quality, but for safety reasons they should not be placed higher than 25 ft (Sanderson 1975). Do not rest the wooden box on a tree limb as wind action may dislodge the box, or tree growth may eventually damage the box (Barkalow and Soots 1965b). Maintenance checks should be made at least once every 2 or 3 years to ensure that the stabilizing wire remains taut and does not cut into the tree or cause stress on the box. One should exercise caution while making maintenance and utilization checks as honeybees, wasps, bumble bees, hornets, and rat snakes (*Elaphe* spp.) may be found in the boxes (Hesselschwerdt 1942, Allen 1943, Barkalow and Soots 1965b, Flyger and Cooper 1967).

RECORDS

A record-keeping system that includes cost, man-hours, location, and utilization data should be developed and maintained for a squirrel nest box program. The placement and subsequent relocation of boxes in a management unit can be aided by using a grid overlay placed over a forest stand map. The scale of the overlay should be chosen so that each grid square represents 1 acre. Up to 1 nest box per acre may then be located at the grid intersections; the actual spacing of boxes will depend on the predetermined installation rate expressed as the number of acres per box.

The box number, location, height of the box above ground, the species and diameter at breast height of the tree on which each box is mounted, associated forest vegetation, and forest stand condition should be recorded when the box is installed. Maintenance and utilization surveys should include condition of box, evidence of vandalism, utilization (including use by nontarget species), and any change noted in the condition of the forest stand. Each field inspection should be dated and signed. The conscientious maintenance of records will be invaluable in relocating boxes during surveys; determining changes needed in the location or number of boxes; and preparing annual reports, work plans, and budgets.

LITERATURE CITED

- Allen, D. L. 1942. Populations and habits of the fox squirrel in Allegan County, Michigan. *Am. Midl. Nat.* 27:338-379.
- _____. 1943. Michigan fox squirrel management. Mich. Dep. Conserv. Game Div. Publ. 100. 404 pp.
- Barkalow, F. S., Jr., and R. F. Soots, Jr. 1965a. An analysis of the effect of artificial nest boxes on a gray squirrel population. *Trans. N. Am. Wildl. Nat. Resour. Conf.* 30:349-360.
- _____, and _____. 1965b. An improved gray squirrel nest box for ecological and management studies. *J. Wildl. Manage.* 29:679-684.
- Brown, L. G. and L. E. Yeager. 1945. Fox squirrels and gray squirrels in Illinois. *Ill. Nat. Hist. Surv. Bull.* 23:449-536.
- Burger, G. V. 1969. Response of gray squirrels to nest boxes at Remington Farms, Maryland. *J. Wildl. Manage.* 33:796-801.
- Fields, H. M. Undated. Box housing project for squirrels. N. C. Agric. Exp. Sta., Raleigh. 2 pp.
- Flyger, V. F., and H. R. Cooper. 1967. The utilization of nesting boxes by gray squirrels. *Proc. Southeast. Assoc. Game Fish Comm.* 21:113-117.
- Hesselschwerdt, R. E. 1942. Use of den boxes in wildlife restoration on intensively farmed areas. *J. Wildl. Manage.* 6:31-37.
- Maryland Game and Inland Fish Commission. Undated. Tire nests for squirrels. 2 pp.
- McComb, W. C., and R. E. Noble. 1981. Nest-box and natural-cavity use in three Mid-South forest habitats. *J. Wildl. Manage.* 45:93-101.
- Mosby, H. S. Undated. The eastern gray squirrel. Va. Polytech. Inst. and State Univ. Ext. Div. Publ. 168. 11 pp.
- Nixon, C. M., and R. W. Donohoe. 1979. Squirrel nest boxes--are they effective in young hardwood stands? *Wildl. Soc. Bull.* 7:283-284.
- _____, S. P. Havera, and R. E. Greenberg. 1978. Distribution and abundance of the gray squirrel in Illinois. *Ill. Nat. Hist. Surv. Biol. Notes* 105. 55 pp.
- Sanderson, H. R. 1975. Den-tree management for gray squirrels. *Wildl. Soc. Bull.* 3:125-131.

END

DTIC

9 - 86