

AD-A171 196

ENVIRONMENTAL IMPACT RESEARCH PROGRAM WATERFOWL NEST
BASKETS SECTION 513. (U) ARMY ENGINEER WATERWAYS
EXPERIMENT STATION VICKSBURG MS ENVIR. L E MARCY

1/1

UNCLASSIFIED

JUL 86 MES/TR/EL-86-15

F/G 13/4

ML

3-11-86

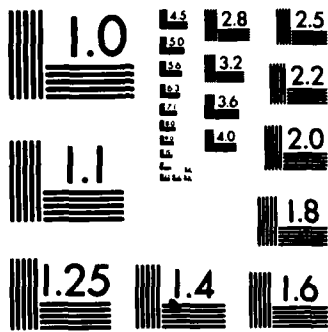

MICROCOPY RESOLUTION TEST CHART
NATIONAL BUREAU OF STANDARDS-1963-A

12

**ENVIRONMENTAL IMPACT
RESEARCH PROGRAM**

TECHNICAL REPORT EL-86-15

WATERFOWL NEST BASKETS

Section 5.1.3, US ARMY CORPS OF ENGINEERS
WILDLIFE RESOURCES MANAGEMENT MANUAL

by

Larry E. Marcy

Environmental Laboratory

DEPARTMENT OF THE ARMY
Waterways Experiment Station, Corps of Engineers
PO Box 631, Vicksburg, Mississippi 39180-0631



US Army Corps
of Engineers

AD-A171 196

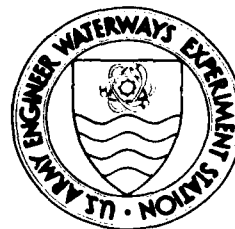
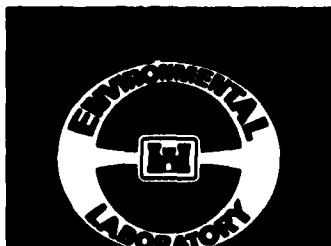
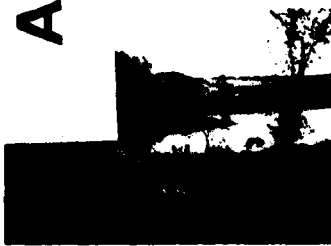

July 1986
Final Report

DTIC
ELECTE
AUG 26 1986
S E D

Approved For Public Release. Distribution Unlimited

DTIC FILE COPY

Prepared for DEPARTMENT OF THE ARMY
US Army Corps of Engineers
Washington, DC 20314-1000
Under EIRP Work Unit 31631

Destroy this report when no longer needed. Do not return
it to the originator.

The findings in this report are not to be construed as an official
Department of the Army position unless so designated
by other authorized documents.

The contents of this report are not to be used for
advertising, publication, or promotional purposes.
Citation of trade names does not constitute an
official endorsement or approval of the use of
such commercial products.

Unclassified

SECURITY CLASSIFICATION OF THIS PAGE

AD-A171196

REPORT DOCUMENTATION PAGE				Form Approved OMB No 0704 0188 Exp Date Jun 30 1986	
1a REPORT SECURITY CLASSIFICATION Unclassified		1b RESTRICTIVE MARKINGS			
2a SECURITY CLASSIFICATION AUTHORITY		3 DISTRIBUTION/AVAILABILITY OF REPORT			
2b DECLASSIFICATION/DOWNGRADING SCHEDULE		Approved for public release; distribution unlimited.			
4 PERFORMING ORGANIZATION REPORT NUMBER(S) Technical Report EL-86-15		5 MONITORING ORGANIZATION REPORT NUMBER(S)			
6a NAME OF PERFORMING ORGANIZATION USAEWES Environmental Laboratory	6b OFFICE SYMBOL (if applicable)	7a NAME OF MONITORING ORGANIZATION			
6c ADDRESS (City, State, and ZIP Code) PO Box 631 Vicksburg, MS 39180-0631		7b ADDRESS (City, State, and ZIP Code)			
8a NAME OF FUNDING/SPONSORING ORGANIZATION US Army Corps of Engineers	8b OFFICE SYMBOL (if applicable)	9 PROCUREMENT INSTRUMENT IDENTIFICATION NUMBER			
8c ADDRESS (City, State, and ZIP Code) Washington, DC 20314-1000		10 SOURCE OF FUNDING NUMBERS			
		PROGRAM ELEMENT NO	PROJECT NO	TASK NO	WORK UNIT ACCESSION NO EIRP 31631
11 TITLE (Include Security Classification) Waterfowl Nest Baskets: Section 5.1.3, US Army Corps of Engineers Wildlife Resources Management Manual					
12 PERSONAL AUTHOR(S) Marcy, Larry E.					
13a TYPE OF REPORT Final report	13b TIME COVERED FROM _____ TO _____	14 DATE OF REPORT (Year, Month, Day) July 1986		15 PAGE COUNT 20	
16 SUPPLEMENTARY NOTATION Available from National Technical Information Service, 5285 Port Royal Road, Springfield, VA 22161.					
17 COSATI CODES			18 SUBJECT TERMS (Continue on reverse if necessary and identify by block number)		
FIELD	GROUP	SUB-GROUP	Waterfowl management Artificial nesting structures Waterfowl nest baskets (Continued)		
19 ABSTRACT (Continue on reverse if necessary and identify by block number) — A management techniques report on waterfowl nest baskets is provided as Section 5.1.3 of the US Army Corps of Engineers Wildlife Resources Management Manual. The report was prepared as a guide to assist Corps biologists and resource managers in developing and implementing waterfowl management programs on Corps lands. Topics covered for nest baskets include waterfowl use, design and construction, installation, placement, maintenance, costs, and cautions and limitations. Specially designed wire fabric nest structures provide the means for potentially increasing breeding populations of waterfowl, especially the mallard (<i>Anas platyrhynchos</i>). The design, construction, installation, placement, and maintenance of four types of nesting structures are described. For purposes of this report, they are referred to as (1) open basket, (2) rectangular basket, (3) horizontal cone, and (4) horizontal cylinder. Detailed (Continued)					
20 DISTRIBUTION AVAILABILITY OF ABSTRACT <input checked="" type="checkbox"/> UNLIMITED <input type="checkbox"/> SAME AS RPT <input type="checkbox"/> DTIC USERS			21 ABSTRACT SECURITY CLASSIFICATION Unclassified		
22a NAME OF RESPONSIBLE INDIVIDUAL			22b TELEPHONE (Include Area Code)		22c OFFICE SYMBOL

18. SUBJECT TERMS (Continued).

Wire nest structures
Mallard
Wildlife management

Waterfowl nesting habitat
Anas platyrhynchos
Management practices and techniques

19. ABSTRACT (Continued).

—specifications and lists of materials required for construction are provided for each design. Recommendations are given for the proper placement and protection of nest structures in suitable habitat to ensure maximum use and productivity. —

Accession For		
NTIS DATA	<input checked="" type="checkbox"/>	
DTIC	<input type="checkbox"/>	
Unannounced	<input type="checkbox"/>	
Distribution/		
Availability Codes		
Distribution/for		
Special		
A-1		



PREFACE

This work was sponsored by the Office, Chief of Engineers (OCE), US Army, as part of the Environmental Impact Research Program (EIRP), Work Unit 31631, entitled Management of Corps Lands for Wildlife Resource Improvement. The Technical Monitors for the study were Dr. John Bushman and Mr. Earl Eiker, OCE, and Mr. Dave Mathis, Water Resources Support Center.

This report was prepared by Mr. Larry E. Marcy, Department of Wildlife and Fisheries Sciences, Texas A&M University, College Station, Tex. Mr. Marcy was employed by the Environmental Laboratory, (EL), US Army Engineer Waterways Experiment Station (WES), under an Intergovernmental Personnel Act contract with Texas A&M University during the period this report was prepared. Mr. Chester O. Martin, Team Leader, Wildlife Resources Team, Wetlands and Terrestrial Habitat Group (WTHG), EL, WES, was principal investigator for the work unit. Mr. Harold A. Doty, US Fish and Wildlife Service, Northern Prairie Wildlife Research Center, Jamestown, N. Dak., provided guidelines on construction, placement, maintenance, and costs of nest structures. Review and comments were provided by Mr. Martin and Dr. Wilma A. Mitchell, WTHG, and Mr. Harold A. Doty, US Fish and Wildlife Service.

The report was prepared under the general supervision of Dr. Hanley K. Smith, Chief, WTHG, EL; Dr. Conrad J. Kirby, Chief, Environmental Resources Division, EL; and Dr. John Harrison, Chief, EL. Dr. Roger T. Saucier, WES, was Program Manager, EIRP. The report was edited by Ms. Jessica S. Ruff of the WES Publications and Graphic Arts Division (PGAD). Drawings were prepared by Mr. John R. Harris, Scientific Illustrations Section, PGAD, under the supervision of Mr. Aubrey W. Stephens, Jr.

At the time of publication, COL Allen F. Grum, USA, was Director of WES, and Dr. Robert W. Whalin was Technical Director.

This report should be cited as follows:

Marcy, Larry E. 1986. "Waterfowl Nest Baskets: Section 5.1.3, US Army Corps of Engineers Wildlife Resources Management Manual," Technical Report EL-86-15, US Army Engineer Waterways Experiment Station, Vicksburg, Miss.

NOTE TO READER

This report is designated as Section 5.J.3 in Chapter 5 -- MANAGEMENT PRACTICES AND TECHNIQUES, Part 5.1 -- NESTING AND ROOSTING STRUCTURES, of the US ARMY CORPS OF ENGINEERS WILDLIFE RESOURCES MANAGEMENT MANUAL. Each section of the manual is published as a separate Technical Report but is designed for use as a unit of the manual. For best retrieval, this report should be filed according to section number within Chapter 5.

WATERFOWL NEST BASKETS

Section 5.1.3, US ARMY CORPS OF ENGINEERS WILDLIFE RESOURCES MANAGEMENT MANUAL

WATERFOWL USE	3	INSTALLATION	12
DESIGN AND CONSTRUCTION	4	PLACEMENT	13
Open Basket	4	MAINTENANCE	13
Rectangular Basket	8	COSTS	14
Horizontal Cone	8	CAUTIONS AND LIMITATIONS	14
Horizontal Cylinder	12	LITERATURE CITED	16

The large-scale use of artificial nest structures to increase waterfowl production has been employed primarily for management of the wood duck (*Aix sponsa*) and Canada goose (*Branta canadensis*). However, specially designed nest structures also provide the means for potentially increasing breeding populations of other species, especially mallards (*Anas platyrhynchos*), where the limiting factor is nesting habitat. Various designs are available, but wire fabric-type structures appear most successful in terms of acceptability by waterfowl, ease of construction, and low cost and maintenance.

The development and management of wire fabric nest structures for waterfowl are discussed in this account. Wire nests have been tested successfully in Iowa, the Dakotas, and other Prairie and Plains states (Burger 1973) and may be suitable for augmenting nesting habitat in other regions.

WATERFOWL USE

Species of waterfowl known to use wire nest structures are the mallard, blue-winged teal (*Anas discors*), gadwall (*A. strepera*), northern pintail (*A. acuta*), redhead (*Aythya americana*), and canvasback (*A. valisineria*). Bishop and Barratt (1970) reported an average of 33% waterfowl use of nest baskets over a 6-year period in Iowa; use was primarily by mallards. Doty et al. (1975) found that 392 of 1038 baskets (37.8%) were used by waterfowl in the

prairie pothole region of the northern United States. Nest success was high in both studies, 87% and 83%, respectively. In comparison, success on natural sites has been reported to range from a low of 27% in agricultural areas of Wisconsin (Gates 1965) to 67% at Greenfield Lake, Montana (Ellig 1955).

Acceptance of artificial nest structures probably relates to an imprinting or learning process (Burger 1973). High nest success over several years was attributed to previously successful nesters and their progeny homing to wire nest baskets (Doty and Lee 1974). These authors found that 46% of female mallards homed at least once to nest baskets in southeastern North Dakota; two-thirds of the birds returning to nests were observed in the same basket where they had been banded. The observed rate of homing by previously successful nesters (52%) was significantly ($P < 0.01$) higher than unsuccessful nesters (16%).

DESIGN AND CONSTRUCTION

The Dutch woven basket was first introduced at the Delta Waterfowl Research Station in Manitoba, Canada, and subsequent designs stemmed from this work (Burger and Webster 1964). The open wire basket was developed for use in the United States by Barratt (1966), Lee et al. (1968), and Bishop and Barratt (1970). Open baskets have proven successful but are subject to avian predation, especially by crows (*Corvus* spp.) (Dwernychuk and Boag 1972, Burger 1973); therefore, covered designs were developed to help reduce egg loss (Doty 1979).

Four types of wire fabric nest structures are described below; for purposes of this report, they are referred to as (1) open basket, (2) rectangular basket, (3) horizontal cone, and (4) horizontal cylinder. Materials required to build each type of structure are listed in Table 1; construction time is approximately 1 to 2 man-hours per structure. Except where cited, information on design and construction was obtained by personal communication with Harold A. Doty of the U.S. Fish and Wildlife Service, Northern Prairie Wildlife Research Center.

Open Basket

The open basket described herein is constructed from a 36-in.-diam circle of 1/4- to 1/2-in.-mesh galvanized hardware cloth. A pie-shaped wedge is cut

Table 1. Materials needed to build four types of wire nest structures for waterfowl

Materials	Quantity
OPEN BASKET	
1/4-in.-diam. × 21-in. cold roll steel rod	4
1/4-in.-diam. × 7-1/2-ft cold roll steel rod	1
1/4- or 1/2-in. hardware cloth (1 sq yd)	1
2-in. ID × 18-in. galv. steel pipe	1
1-1/2-in. × 10-ft ID galv. steel pipe	1
3/8- × 1-in. hexhead bolt and nut	1
Hog rings, small (or use wire)	20 (or 2 ft of 12-1/2-ga wire)
RECTANGULAR BASKET	
1- × 2-in. 14-ga. welded wire mesh (25 × 30 in.)	1
2-in. ID × 12-in. galv. steel pipe (1-1/2-in. ID optional)	1
1-1/2-in. × 10-ft ID galv. steel pipe	1
1/8- × 1- × 18-in. angle iron	1
1/4-in.-diam. × 48-in. cold roll steel rod (plus 28 in. for optional rod ends)	1
Hog rings, large	8
Hog rings, regular	10
3/8- × 1-in. hexhead bolt and nut	1
HORIZONTAL CONE	
1/4- or 1/2-in. hardware cloth (12 sq ft or 32 × 44 in.)	1
20-ga. galv. sheet metal or sheet aluminum (12 × 18 in.) or roofing paper	1
1/4- × 12-in. cold roll steel rod	4
2-in. ID × 18-in. galv. steel pipe (1-1/2-in. ID optional)	1
1-1/2-in. ID × 10-ft galv. steel pipe	1
3/8- × 1-in. hexhead bolt and nut	1
Hog rings, medium (or use wire)	8 (or 2 ft of 12-1/2-ga wire)
1/4- × 18-in. wooden lath	4
HORIZONTAL CYLINDER	
1- × 2-in. welded wire mesh (22 × 44 in.)	1
20-ga. galv. sheet metal or sheet aluminum (20 × 24 in.) or roofing paper	1
1/4-in.-diam. × 4-ft cold roll steel rod	1
2-in. ID × 18-in. galv. steel pipe (1-1/2-in. ID optional)	1
1-1/2-in. ID × 10-ft galv. steel pipe	1
3/8- × 1-in. hexhead bolt and nut	1
Hog rings, small (or use wire)	6 (or 2 ft of 12-1/2-ga wire)
1/4- × 24-in. wooden lath	4

out of the circle, leaving the wire tabs on the body of the circle and not the wedge (Fig. 1). The cone is formed by joining the edges of the notch and fastening them together with the wire tabs. Four small hog rings can be added to the seam for additional strength.

Support for the basket rim is made by bending a 1/4-in. \times 7-1/2-ft steel rod into a hoop and welding the ends together. The diameter of the hoop will be approximately 1 in. smaller than that of the basket. The basket is placed inside the hoop, and the rim of the basket is bent down around the hoop. Basket brace rods are made from four 1/4- \times 21-in. steel rods and are attached to the hoop by bending the ends of the rods around the hoop (Fig. 1). For additional strength, 2 small hog rings can be attached to the basket rim and hoop equidistant between the brace rods. Hog rings can also be used to secure the basket to the rods.

The basket brace pipe is made from a 2-in. ID (inside diameter) galvanized steel pipe 18 in. long, or any suitable diameter pipe that will fit over the support pipe (see Installation). The top end of the brace pipe is partially closed off by welding a small piece of 1/4-in. steel plate to the top inside edge of the pipe or by welding a bead in 2 places along the inside edge (Fig. 1, section detail); this will serve as a "stop" to prevent the support pipe from pushing through the basket. A 7/16-in.-diam hole is drilled in the side of the brace pipe approximately 16 in. below the brace rods, and a 3/8-in. hexnut is welded over the hole; a 3/8- \times 1-in. hexhead bolt can then be screwed into the nut and used as a lockbolt on the support pipe. Basket brace rods are welded equidistant around the top outside edge of the pipe, as shown in Figure 1. A 3-in.-diam adjustable automotive hose clamp can be used to hold the brace rods in place for welding.

All of the nest structures are designed to be installed over a 1-1/2-in. (ID) \times 7- to 10-ft-long galvanized steel pipe (Fig. 1). However, each design can be built so that the brace pipe fits inside the support pipe (see optional mount, Fig. 1). The end of the support pipe to be driven into the substrate should be hammered closed, and 1/4-in.-diam holes are drilled in the pipe at 2-ft intervals; this will permit water drainage and will prevent freezing water from bursting the pipe. A tight-fitting predator guard should always be attached to the support pipe 2 to 3 ft below the nest (see designs presented in Section 5.1.2, WOOD DUCK NEST BOXES).

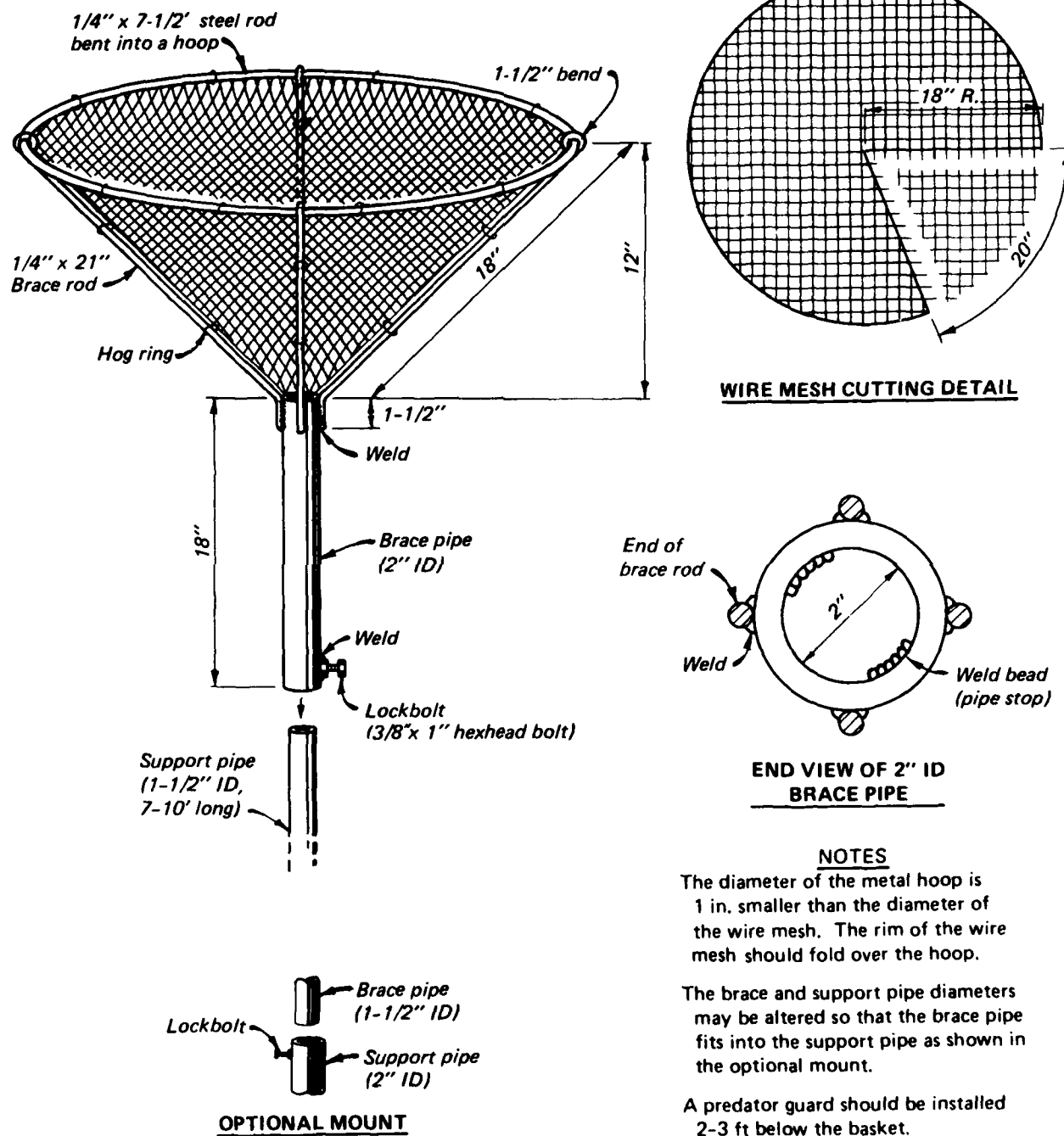

Figure 1. Design specifications for an open basket nest structure for waterfowl (adapted from U.S. Fish and Wildlife Service 1970)

Rectangular Basket

The open-top rectangular nest structure provides a rigid and durable unit with a minimum of hardware (Doty, pers. commun., 1984). It is constructed from a 25- × 30-in. piece of 1- × 2-in., 14-ga. welded wire mesh. Each end of the wire fabric (shorter dimension) is notched to form end flaps (Fig. 2). The end flaps are bent perpendicular to the body of the basket, and the body is folded along the center line (parallel to the long dimension) to form 2 sides approximately 14 in. apart. To facilitate shaping the wire basket, a sturdy wooden frame (jig) should be made, around which the wire mesh can be bent and folded with the aid of a hard rubber mallet (Doty, pers. commun., 1984). The end flaps are squared by folding the top of each flap down against the end of the structure; three hog rings should be used to secure each flap (Fig. 2, folding detail - end view).

The support frame is constructed by welding two 1/4- × 12-in. steel rods in the notch-ends of a 1/8- × 1- × 18-in. length of angle iron (Fig. 2); the free ends of each pair of rods should be approximately 14 in. apart. For additional support, a 1/4- × 14-in. steel rod may be welded between the free ends of each pair of rods. The completed frame is welded to the end of a 2-in. (ID) × 12-in. steel pipe that has been notched to fit the angle iron. The brace pipe can fit over the support pipe or inside the support pipe using the optional mount; the diameter of the brace pipe and the positioning of the lockbolt should be adjusted accordingly.

Two large hog rings per steel rod are used to secure the basket to the frame; hog rings can be used between the shoat rings for additional support. The sides of the welded rectangular basket provide sufficient rigidity to fasten an arched metal cover where protection of duck eggs from avian predators is needed.

Horizontal Cone

Covered nest basket designs such as horizontal cones and cylinders incorporate overhead visual screening to protect eggs from discovery by avian predators. Doty (1979), in a study comparing 3 types of nest structures, found the cone type to be preferred by mallards over the open basket and cylinder; however, there was no difference in nest success among structures. The covered wire fabric cone and cylinder presented here are from Doty (1979).

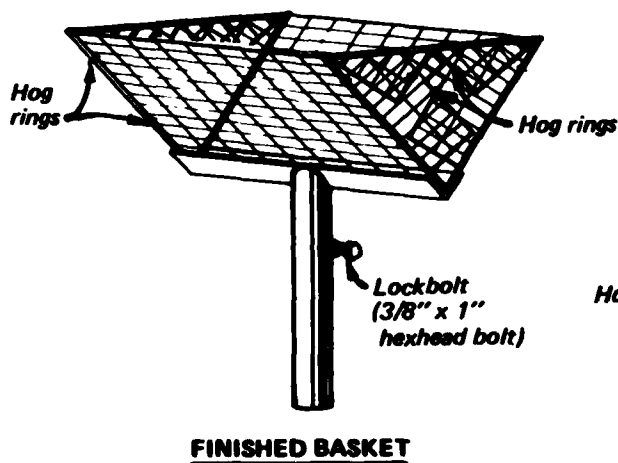
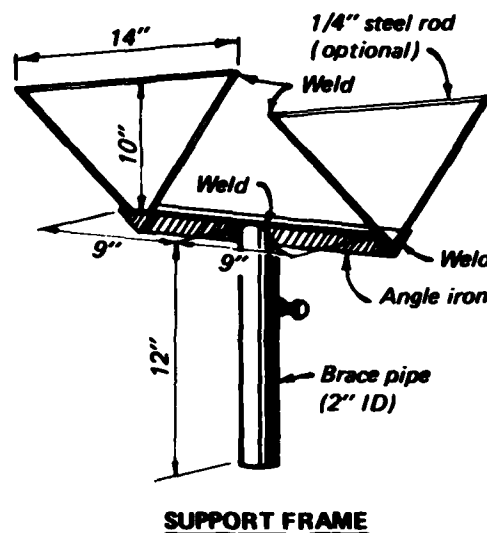
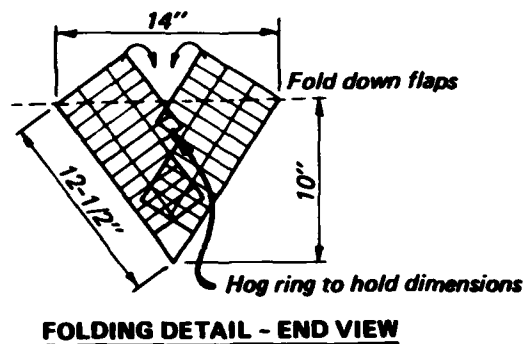
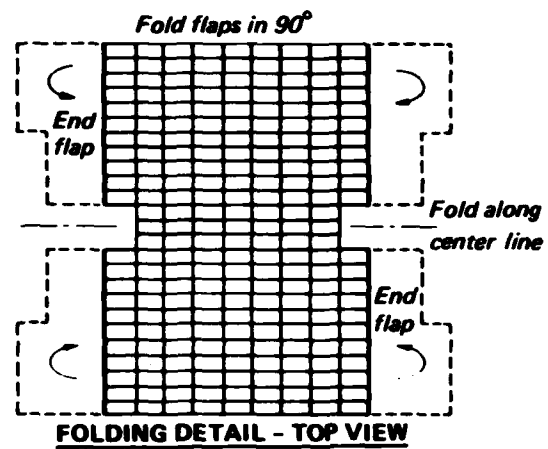
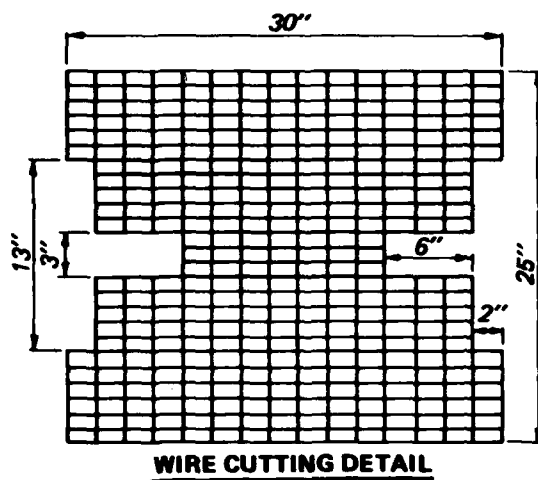

Figure 2. Design specifications for a rectangular basket nest structure for waterfowl (courtesy Harold A. Doty, U.S. Fish and Wildlife Service, Northern Prairie Wildlife Research Center)

Similar structures using wire and other materials such as roofing paper or sisalcraft are described in Burger (1973).

The horizontal cone is constructed from a 32- × 44-in. piece of 1/4- or 1/2-in.-mesh hardware cloth rolled into a cone approximately 14 in. in diameter and 32 in. long (Fig. 3). Although more material is used, it is easier to roll the wire to shape and trim the ends than to cut the fabric to shape and join the edges together. Wire tabs along each edge of fabric can be used to knit the seam together. The ends should be squared with tin snips, and sharp edges and excess tabs should be removed.

A protective roof can be made by cutting a 12- × 18 in. piece of roofing paper and wiring it inside the cone or by cutting a piece of 20-ga. galvanized sheet metal or sheet aluminum (approximately 12 × 18 in.) and bending it to fit inside the top of the cone. Four 1/4- × 18-in. wooden strips (lath) should be wired under the roofing paper for support. Attachment of the metal cover inside the cone is made by wire via three 1/8-in.-diam holes drilled equidistant along the sides of the cover. In addition to providing screening cover, the metal top also gives support to the wire fabric and helps hold its shape.

The support frame is constructed of four 12-in.-long pieces of 1/4-in. steel rod attached to the inside of the cone with hog rings, as shown in Figure 2. Two holes are cut in the top and bottom of the cone to permit attachment of the cone over the brace pipe. The 1/4-in. steel rods are then welded to the sides of a 2-in. (ID) × 18-in. galvanized steel pipe, as shown in Figure 2. A 3/8-in. locknut can be welded to the side of the brace pipe as done for the open basket. An optional method of attaching the nest unit to the support pipe is to use a brace pipe of suitable diameter (1-1/2 in.) to fit inside the support pipe (Fig. 1). The support pipe should be drilled and tapped to receive a 3/8- × 1-in. bolt, or a 7/16-in.-diam hole can be drilled in the support pipe and a 3/8-in. hexhead nut welded over the hole.

Horizontal cones and cylinders should be mounted on support pipes as described for the open basket, and a predator guard should be attached to the support pipe. Protective metal covers should be painted flat green or brown to reduce reflection and aid concealment from aerial predators.

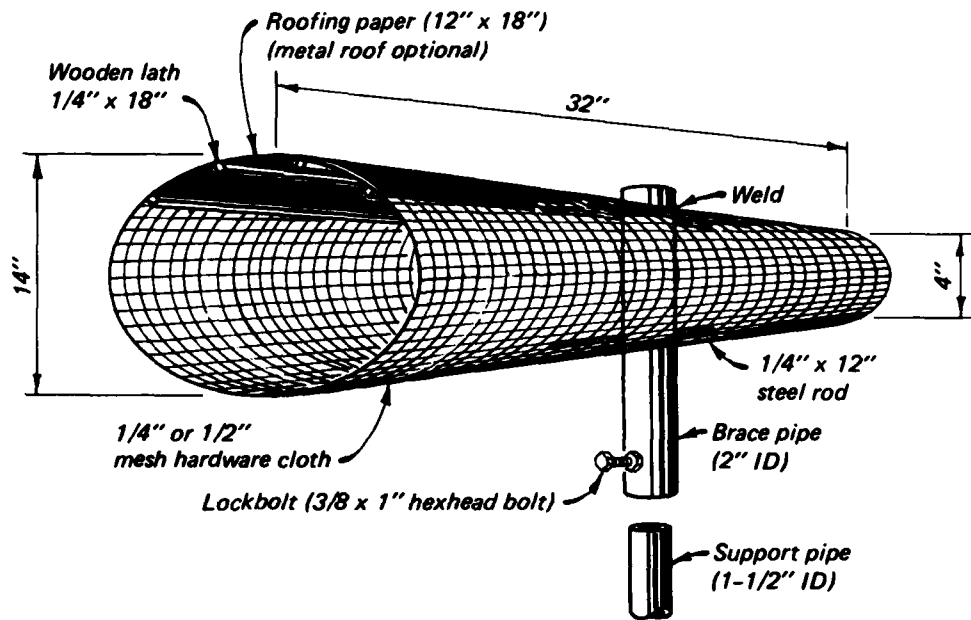

CONE

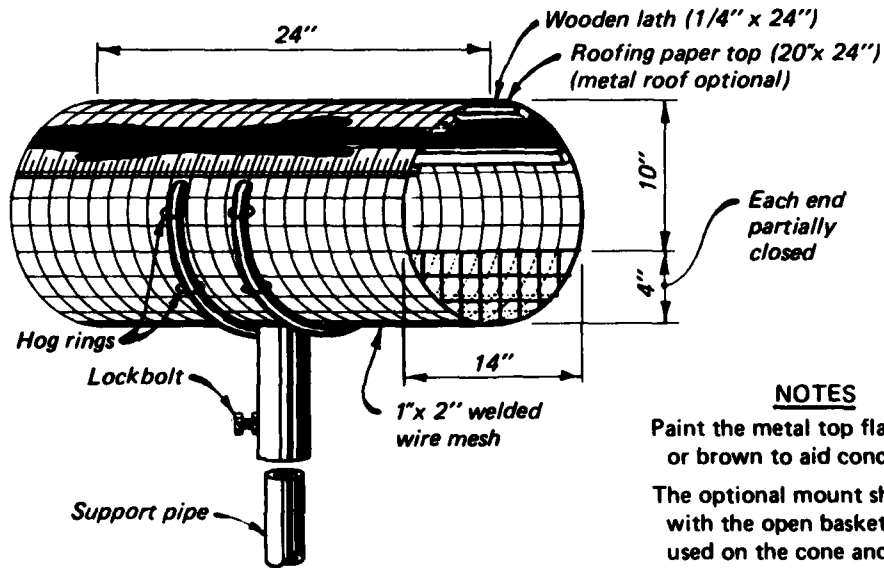

CYLINDER

NOTES

- Paint the metal top flat green or brown to aid concealment.
- The optional mount shown with the open basket may be used on the cone and cylinder.
- A predator guard should be installed 2-3 ft below the basket.
- Wooden lath to support roofing paper

Figure 3. Design specifications for horizontal cone and cylinder nest structures for waterfowl (adapted from Doty 1979)

Horizontal Cylinder

The horizontal cylinder is constructed from a 24- × 44-in. piece of 1- × 2-in. welded wire mesh, which is rolled into a cylinder approximately 14 in. in diameter and 24 in. long (Fig. 3). The wire tabs left from trimming the mesh should be used to knit the edges of the mesh together.

Roofing paper, galvanized sheet metal, or sheet aluminum, 20 × 24 in., should be bent to fit inside the top of the cylinder and fastened in place with wire, as done for the cone. If roofing paper is used, four 1/4- × 24-in. wooden strips (lath) should be wired under the paper for support. Approximately one-third of each end of the cylinder should be covered with a 4- × 14-in. semicircle of welded wire mesh to retain nest materials. The cylinder support is constructed by welding 2 semicircular 1/4- × 24-in. steel rods to one end of a 2-in. (ID) × 18-in. galvanized steel pipe (Fig. 3). A 3/8-in. locknut should be welded on the side of the pipe as was done for the open basket support, or the optional brace pipe can be used. The cylinder is attached to the rods with small hog rings or wire.

INSTALLATION

The nest basket should be installed over water, and the support pipe set at least 1-1/2 ft deep on firm sites or 3 to 4 ft deep in soft muck-bottomed wetland soils (Doty et al. 1975). The basket height should be 3 to 4 ft above the water surface (Bishop and Barratt 1970). Although ducks readily use baskets that are greater than 4 ft above the water surface, hawks and owls find these taller baskets ideal perches. Baskets less than 2 ft above water are within easy reach of predators.

Wood shavings may be used as a base for nest materials (Burger 1973), or nest structures may be lined from 2 to 4 in. thick with grass or straw. Nest materials should be wired to the basket, leaving a depression in the center, and loose nest materials should be placed in the depression up to the rim (Doty 1979).

PLACEMENT

Sites chosen for nest basket placement have a direct influence on use by waterfowl. Doty et al. (1975) found that waterfowl in the prairie pothole region use artificial nest structures more than waterfowl in forest or pasture-stockpond sites. Baskets may be erected in open water or in protected sites close to marshes but should never be located on dry land (Bishop and Barratt 1970). When nest structures are located in marsh sites, they may be spaced evenly around the perimeter and from 30 to 300 ft from shore in water at least 2 to 3 ft deep (Doty et al. 1975, Yoakum et al. 1980). An alternate plan is to locate baskets in groups of 4 spaced 180 to 300 ft apart; one cluster of baskets per mile of shoreline is recommended (Yoakum et al. 1980). Bishop and Barratt (1970) recommend a density of 1 basket per 1.5 acres.

Nest structures should be erected in moderate rather than dense stands of emergent vegetation, because those placed in dense vegetation are rarely used. In North and South Dakota, Doty et al. (1975) found that wire nest structures located in emergent vegetation with scattered openings were used most often. However, vegetation should not restrict the movement of broods to brood-rearing habitat. In Iowa, Bishop and Barratt (1970) found that structures placed in large bodies of water were used frequently by waterfowl, but ice movement caused high basket loss.

Fluctuations in water level can also affect nest basket use. During periods of high water, many additional natural nest sites are available to waterfowl and may cause a decline in nest basket use. Droughts often leave baskets isolated on dry land and unused. Therefore, potential sites for placement should be evaluated in terms of periodic water fluctuation.

MAINTENANCE

Nest structures should be inspected annually prior to the breeding season. If necessary, maintenance should consist of cleaning out nest remains, adding straw, repairing the baskets, and resetting tilted poles (Doty 1979). Inspection and routine maintenance may require approximately 10 to 20 min per structure (Doty, pers. commun., 1984). Doty et al. (1975) found that flax straw nest materials last from 3 to 5 years, but other materials such as

grass, hay, or soft straw should be replaced on an annual basis. Nest material retaining wire should be replaced every 3 years.

Galvanized wire nest structures are potentially long lived. Doty et al. (1975) found that in the prairie pothole region they were structurally sound after 7 years and could be usable for 20 or more years. Baskets erected in 1967 were still usable in 1984 (Doty, pers. commun., 1984). Longevity is determined by the quality of materials used in construction and the protection from wind and ice afforded by the site.

COSTS

The cost of new materials required to build a basket, cone, or cylinder (with galvanized pipe) is approximately \$27 (1984 prices). This initial cost can be prorated over the life span of the structure; e.g., if a structure lasts 20 years, the cost would be \$1.35 per year. Rectangular nest structures require fewer materials and are less expensive. If new materials are purchased for the basket and frame and old water pipe is used for the support, the cost for an entire unit is approximately \$7.25. The annual maintenance cost for all types of baskets is approximately \$3 per structure.

CAUTIONS AND LIMITATIONS

The prerequisites for producing localized, high-density waterfowl populations include (1) provision of adequate nest and brood habitat, (2) control of excessive predation, and (3) possible restriction of hunting near nesting hens (Doty and Lee 1974). Artificial wire nest structures can be used to augment nesting habitat, but it is the manager's responsibility to provide brooding habitat at or adjacent to the site and to protect the hens from excessive predation and human disturbance. Unless artificial nest structures provide safer nest sites than natural ones, they do little to enhance productivity (Bellrose and Low 1978).

Artificial nest structures must always be protected from climbing predators (Bellrose and Low 1978). Major nest predators are the fox squirrel (*Sciurus niger*), raccoon (*Procyon lotor*), and rat snake (*Elaphe obsoleta*).

Metal "truncated cones" or metal sheet "sandwiching" should be attached to the support to prevent predators from climbing the pole (Burger and Webster 1964).

Human disturbance of waterfowl using artificial baskets was determined to be a major cause of nest abandonment (Bishop and Barratt 1970, Dwernychuk and Boag 1972, Doty et al. 1975, Strang 1980). Dwernychuk and Boag (1972) suggested that disturbance of the vegetation in the vicinity of a nest site (in effect creating an obvious trail to the nest) enabled avian predators to easily locate nests. Therefore, the installation and maintenance of nest structures should be accomplished prior to the nesting season, and observations and other forms of disturbance should be minimal while birds are on their nests.

Duck hunting in the vicinity of nesting areas has a detrimental effect on nesting females. Doty and Lee (1974) found that adult females were most vulnerable to hunting mortality near the nest basket site. Jessen (1970) also found a high rate of female mortality near the nesting area. Therefore, hunting on waterfowl production areas should be controlled, as the numbers of experienced nesters on baskets could be depleted and decrease productivity in future years (Doty and Lee 1974).

Baskets are subject to damage by the elements. Therefore, they should be erected in sheltered areas to reduce damage from ice, wind, and wave action. Doty et al. (1975) found that approximately 7% of artificial nest structures were lost annually to these factors.

LITERATURE CITED

- Barratt, B. 1966. Predator proof nests. *Iowa Conserv.* 25:23.
- Bellrose, F. C., and J. B. Low. 1978. Advances in waterfowl management research. *Wildl. Soc. Bull.* 6:63-72.
- Bishop, R. A., and R. Barratt. 1970. Use of artificial nest baskets by mallards. *J. Wildl. Manage.* 34:734-738.
- Burger, G. V. 1973. *Practical Wildlife Management.* Winchester Press, New York. 218 pp.
- _____, and C. G. Webster. 1964. Instant nesting habitat. Page 656 In J. P. Linduska, ed. *Waterfowl Tomorrow.* U.S. Gov. Printing Off., Washington, D.C. 770 pp.
- Doty, H. A. 1979. Duck nest structure evaluations in prairie wetlands. *J. Wildl. Manage.* 43:976-979.
- _____, and F. B. Lee. 1974. Homing to nest baskets by wild female mallards. *J. Wildl. Manage.* 38:714-719.
- _____, _____, and A. D. Kruse. 1975. Use of elevated nest baskets by ducks. *Wildl. Soc. Bull.* 3:68-73.
- Dwernychuk, L. W., and D. A. Boag. 1972. How vegetative cover protects duck nests from egg-eating birds. *J. Wildl. Manage.* 36:955-958.
- Ellig, L. J. 1955. Waterfowl relationships to Greenfield Lake, Teton County, Montana. *Mont. Fish and Game Dept., Tech. Bull. No. 1.* 35 pp.
- Gates, J. M. 1965. Duck nesting and production of Wisconsin farmlands. *J. Wildl. Manage.* 29:515-523.
- Jessen, R. L. 1970. Mallard population trends and hunting losses in Minnesota. *J. Wildl. Manage.* 34:93-105.
- Lee, F. B., A. D. Kruse, and W. H. Thornsberry. 1968. New fashions for the duck marsh. *Naturalist* 19:27-32.
- Strang, C. A. 1980. Incidence of avian predators near people searching for waterfowl nests. *J. Wildl. Manage.* 44:220-222.
- U.S. Fish and Wildlife Service. 1970. New homes for prairie ducks. *U.S. Fish and Wildl. Serv.* 5 pp.
- Yoakum, J., W. P. Dasmann, H. R. Sanderson, C. M. Nixon, and H. S. Crawford. 1980. Habitat improvement techniques. Pages 329-403 In S. D. Schemnitz, ed. *Wildlife Management Techniques Manual.* The Wildl. Soc., Washington, D.C. 686 pp.

END

DTIC

9 - 86