

AD-A171 463

WATERSHED SEDIMENTATION INVESTIGATION FOR THE MENTONE
DANCO) HYDROLOGIC ENGINEERING CENTER DAVIS CA
R C MACARTHUR SEP 83 HEC-SP-83-4

1/1

UNCLASSIFIED

F/G 8/8

NL

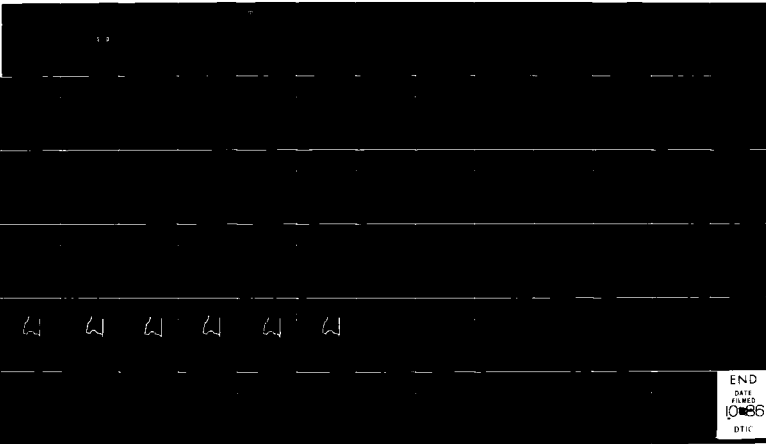

END
DATE
FILMED
10 86
DTIC

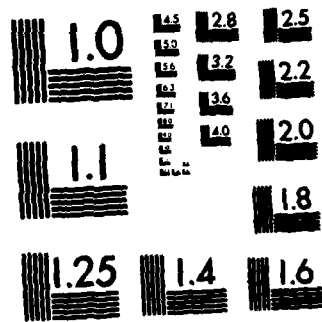

MICROCOPY RESOLUTION TEST CHART
NATIONAL BUREAU OF STANDARDS-1963-A



US Army Corps
of Engineers

The Hydrologic
Engineering Center



AD-A171 463

Watershed Sedimentation Investigation for the Mentone Dam

DTIC
SELECTE
SEP 02 1986
S D
D

Prepared for
Los Angeles District
US Army Corps of Engineers

W/E

DISTRIBUTION STATEMENT A
Approved for public release;
Distribution Unlimited

DTIC FILE COPY

Special Projects Memo No. 83-4
September 1983

86 9 2 072

| REPORT DOCUMENTATION PAGE | | READ INSTRUCTIONS BEFORE COMPLETING FORM |
|---|-----------------------|---|
| 1. REPORT NUMBER | 2. GOVT ACCESSION NO. | 3. RECIPIENT'S CATALOG NUMBER |
| 4. TITLE (and Subtitle) Watershed Sedimentation Investigation for the Mentone Dam. | | 5. TYPE OF REPORT & PERIOD COVERED Special Projects Memo No. 83-4 |
| | | 6. PERFORMING ORG. REPORT NUMBER |
| 7. AUTHOR(S) | | 8. CONTRACT OR GRANT NUMBER(s) |
| 9. PERFORMING ORGANIZATION NAME AND ADDRESS U.S. Army Corps of Engineers, Los Angeles District P.O. Box 2711, Los Angeles, Calif 90053 | | 10. PROGRAM ELEMENT, PROJECT, TASK AREA & WORK UNIT NUMBERS |
| 11. CONTROLLING OFFICE NAME AND ADDRESS U.S. Army Corps of Engineers Los Angeles District, P.O. Box 2711 Los Angeles, California 90053 | | 12. REPORT DATE September 1983 |
| | | 13. NUMBER OF PAGES |
| 14. MONITORING AGENCY NAME & ADDRESS (if different from Controlling Office) | | 15. SECURITY CLASS. (of this report) Unclassified |
| | | 15a. DECLASSIFICATION/DOWNGRADING SCHEDULE |
| 16. DISTRIBUTION STATEMENT (of this Report) Approved for public release; distribution unlimited. | | |
| 17. DISTRIBUTION STATEMENT (of the abstract entered in Block 20, if different from Report) | | |
| 18. SUPPLEMENTARY NOTES Available from National Technical Information Service, 5285 Port Royal Road, Springfield, Virginia 22161 | | |
| 19. KEY WORDS (Continue on reverse side if necessary and identify by block number) Sediment Transport- Upper Santa Ana River Mentone Dam Project Investigations Watershed sedimentation Upper Santa Ana River-Drainage Basin | | |
| 20. ABSTRACT (Continue on reverse side if necessary and identify by block number) This report is an evaluation of the sedimentation characteristics of the pro- posed Mentone Dam. It describes the topography, geology, climate and land usages of the area. The upper Santa Ana River drainage was partitioned into six contributing watersheds from Big Bear to Mentone. Each watershed is analyzed for its potential sediment contribution to the Santa Ana River. The results are summed and evaluated with respect to their potential impact on the proposed Mentone Dam and Reservoir. The study represent the best estimate of | | |

the extent and character of reservoir delta sediment materials. Further study may be warranted during the dam's design for minimizing the impact of sediment deposition in the reservoir.



**US Army Corps
of Engineers**

**The Hydrologic
Engineering Center**

Watershed Sedimentation Investigation for the Mentone Dam

**Prepared for
Los Angeles District
US Army Corps of Engineers**

Special Projects Memo No. 83-4

September 1983

WATERSHED SEDIMENTATION INVESTIGATION FOR
THE MENTONE DAM

By
Robert C. MacArthur, Ph.D., P.E.

Special Projects Memo No. 83-4

Prepared for
Department of the Army
Los Angeles District, Corps of Engineers

The Hydrologic Engineering Center
609 Second Street
Davis, California 95616

September 1983

| | |
|--------------------|-------------------------------------|
| Accession For | |
| NTIS CRA&I | <input checked="" type="checkbox"/> |
| DTIC TAB | <input type="checkbox"/> |
| Unannounced | <input type="checkbox"/> |
| Justification | |
| By | |
| Distribution/ | |
| Availability Codes | |
| Dist | Avail and/or Special |
| A-1 | |



PREFACE

On 11 August 1982, the Los Angeles District, U.S. Army Corps of Engineers (SPL) authorized the Hydrologic Engineering Center (HEC) to perform an evaluation of the sedimentation characteristics of the proposed Mentone Dam. The investigation was completed for the Los Angeles District under Project Order No. CIV 83-11, dated 17 November 1982. This report presents the results of that investigation and summarizes the factors that influence sediment transport along the Upper Santa Ana River Drainage Basin near Mentone, California. These data, procedures and observations supplement the Phase I GDM and Groundwater Modeling Studies being conducted by the Los Angeles District, U.S. Army Corps of Engineers.

The primary objectives of the investigation were: (1) to identify major physical, climatological, and geological factors affecting erosion and yield of sediment within the study area; (2) to quantify total sediment erosion and yield for various hydrologic conditions; and (3) to estimate the extent, shape and character of sediment deltas likely to form within this reservoir. Special attention was given to the effects of fire on erosion and sedimentation in the study area.

The Los Angeles District has used the results of this investigation in their assessment of the effects that sediment deposition may have on infiltration and overall groundwater recharge in the Mentone area.

Information and data used to prepare this document were extracted from many reports, publications, and personal discussions listed in the References section and Appendix of this report.

Personnel from the Hydrologic Engineering Center performed this study under the direction of Arlen D. Feldman, Chief of the Research Branch and Bill S. Eichert, Director of the Hydrologic Engineering Center. Robert C. MacArthur conducted the study and prepared the final report.

The Hydrologic Engineering Center is grateful to the Los Angeles District and particularly to Dr. Abnish Amar, Mr. David Cozakos and Mr. Dennis Majors for their cooperation, suggestions and assistance throughout this project.

TABLE OF CONTENTS

| | <u>Page</u> |
|--|-------------|
| Preface | i |
| List of Tables | iii |
| List of Figures | iv |
| Summary | 1 |
| Introduction | 3 |
| Description of Study Area | 4 |
| Geology | 4 |
| Hydrology | 4 |
| Mentone Dam | 6 |
| Erosion and Sediment Yield | 9 |
| Factors Affecting Erosion and Sediment Yield | 9 |
| Effects of Fire on Peak Discharge | 12 |
| Effects of Fire on Sediment Yield | 13 |
| Sediment Yield to Mentone Damsite | 17 |
| Contributing Watersheds | 17 |
| Hydrologic and Watershed Burn Conditions | 17 |
| Current Burn Average Annual Sediment Production | 19 |
| Reasonable Maximum Burn Average Annual Sediment Production | 21 |
| Estimated Standard Project Flood Sediment Production | 24 |
| Extent, Thickness and Composition of Deltas in the Mentone Reservoir | 36 |
| Application of Computer Program HEC-6 | 36 |
| Delta Simulations | 36 |
| Conclusions | 59 |
| References | 61 |
| Appendix | 65 |

LIST OF TABLES

| <u>Table</u> | <u>Page</u> |
|---|-------------|
| 1 Characteristics of the Proposed Mentone Dam | 8 |
| 2 Estimated Sediment Production Rates for Watersheds Contributing Sediment to the Proposed Mentone Damsite Under Current Burn Watershed Conditions | 20 |
| 3 Sedimentation Data for Reservoirs Located in the San Gabriel Mountains | 22 |
| 4 Estimated Sediment Production for Reasonable Maximum Burn Conditions due to Average Annual Precipitation Occurring on All Watersheds with Less Than One Year of Reforestation Recovery Time | 23 |
| 5 Estimated Standard Project Flood Sediment Production | 27 |
| 6 Estimated Thicknesses of Sediment Deposits at the Mentone Damsite Using Empirical Approximations | 37 |
| 7 Summary of Graphical and Tabular Results | 39 |
| 8 Grain Size Distribution at the Mentone Damsite As a Result of the Mean Annual Flood and Current Burn Conditions | 52 |
| 9 Grain Size Distribution at the Mentone Damsite As a Result of the Mean Annual Flood and Reasonable Maximum Burn Conditions | 53 |
| 10 Grain Size Distribution at the Mentone Damsite As a Result of the SPF and Current Burn Conditions | 54 |
| 11 Grain Size Distribution at the Mentone Damsite As a result of the SPF and Reasonable Maximum Burn Conditions | 55 |
| 12 Grain Size Distribution at the Mentone Damsite As a Result of Fifty Years of Mean Annual Deposits Under Current Burn Conditions | 56 |
| 13 Simulated Depths of Deposited Sediment for Various Hydrologic Events and Watershed conditions | 57 |

LIST OF FIGURES

| <u>Figure</u> | <u>Page</u> |
|--|-------------|
| 1 Location Map | 5 |
| 2 Sketch of Proposed Mentone Dam | 7 |
| 3 Effect of Forest Fire Frequency on Sediment Erosion and Yield in A Typical Watershed | 11 |
| 4 Relationship of Erosion Rates and Normal Peak Discharge | 14 |
| 5 Relation of Erosion Rate to Peak Storm Discharge for Various Forest Fire Recovery Times | 15 |
| 6 Runoff and Sediment Contributing Watersheds for the Santa Ana River at the Mentone Damsite | 18 |
| 7 Runoff and Sediment Contributing Watersheds for the Santa Ana River at Mentone, California with their Estimated Average Annual Sediment Production Rates. | 26 |
| 8 Subbasin Peak Discharge Frequency for Two Different Forest Fire Burn Histories - SANTA ANA RIVER (ABOVE MENTONE) | 28 |
| 9 Subbasin Peak Discharge Frequency For Two Different Forest Fire Burn Histories - OAK CREEK | 29 |
| 10 Subbasin Peak Discharge Frequency For Two Different Forest Fire Burn Histories - PLUNGE CREEK | 30 |
| 11 Subbasin Peak Discharge Frequency For Two Different Forest Fire Burn Histories - MILL CREEK | 31 |
| 12 Subbasin Peak Discharge Frequency For Two Different Forest Fire Burn Histories - MILL CREEK WASH | 32 |
| 13 Subbasin Peak Discharge Frequency For Two Different Forest Fire Burn Histories - MORTON CANYON | 33 |
| 14 Relation of Erosion Rate to Peak Storm Discharge for Various Forest Fire Recovery Times | 34 |
| 15 Runoff and Sediment Contributing Watersheds for the Santa Ana River at the Mentone Damsite with their Estimated Standard Project Flood Sediment Production Rates | 35 |
| 16 Simulated Mean Annual Current Burn Delta | 41 |
| 17 Simulated Mean Annual Reasonable Maximum Burn Delta | 42 |

| <u>Figure</u> | | <u>Page</u> |
|---------------|---|-------------|
| 18 | Simulated Standard Project Flood Current Burn Delta | 43 |
| 19 | Simulated Standard Project Flood Reasonable Maximum Burn Delta | 44 |
| 20 | Fifty Year Delta, Mean Flows and Current Burn | 45 |
| 21 | Mean Annual Flood Simulated Spatial Distribution of Sediment Deposits In The Reservoir For Current Burn Forest Conditions | 46 |
| 22 | Mean Annual Flood Simulated Spatial Distribution of Sediment Deposits in the Reservoir For Reasonable Maximum Burn Forest Conditions | 47 |
| 23 | Standard Project Flood Simulated Spatial Distribution of Sediment Deposits in the Reservoir for Current Burn Forest Conditions | 48 |
| 24 | Standard Project Flood Simulated Spatial Distribution of Sediment Deposits in the Reservoir For Reasonable Maximum Burn Forest Conditions | 49 |
| 25 | Fifty Year Simulation of the Spatial Distribution of Sediment Deposits in the Reservoir For Current Burn Forest Conditions | 50 |
| 26 | One Hundred Year Simulation of the Spatial Distribution of Sediment Deposits in the Reservoir For Current Burn Forest Conditions | 51 |
| 27 | Typical Reservoir Delta Form | 58 |

SUMMARY

This report presents the methods, data and results of an investigation to evaluate the sedimentation characteristics and potential delta formation in the proposed Mentone Reservoir. This study was performed by the Hydrologic Engineering Center (HEC), Davis, California, for the Los Angeles District, U.S. Army Corps of Engineers.

Information pertaining to the description of the study area, its topography, geology, climate, and land usage is presented briefly here and in greater detail in previous Corps documents (U.S. Army Corps of Engineers, 1980). For this study the Upper Santa Ana River drainage was partitioned into six contributing watersheds from Big Bear Lake to Mentone. Each of these watersheds was analyzed for its potential sediment contribution to the Santa Ana River. These results were then summed and evaluated with respect to their potential impact on the proposed Mentone Dam and Reservoir.

Climate, soil types, topography, plant cover and degree of channelization usually determine sediment yield from mountainous regions. In the Upper Santa Ana River basin, the periodic occurrence of brush and forest fires greatly increases sediment erosion rates and yield in its watersheds. Therefore, it was very important to determine the effects of fire on peak discharge and erosion for each of the six contributing watersheds above the Mentone damsite. "Current burn" (CB) conditions represent watershed conditions that reflect the cumulative effect of various forest fires that have occurred in the basin to date. "Reasonable maximum burn" (RMB) conditions were also analyzed in order to evaluate "worst likely" watershed conditions due to fire damages.

For average annual flow conditions, the total sediment production for current burn watershed conditions would be approximately 443,000 cubic yards per year, and for reasonable maximum burn conditions it would be 5,390,000 cubic yards per year. The estimated sediment production for the same area during a standard project flood event is estimated to be 2,026,000 cubic yards and 14,709,000 cubic yards for current burn and reasonable maximum burn conditions, respectively.

Maximum delta thickness determined with computer program HEC-6 varied from about 2 to 15 feet for mean annual flows corresponding to CB and RMB watershed conditions, respectively. After fifty years of average annual flows and current burn conditions, a maximum delta thickness of 34 feet was estimated. The maximum thickness of deposits after one hundred years was extrapolated to be between 40 and 50 feet.

The distributions of sediment grain sizes are tabulated as the "percentage finer than by weight" for each grain size at each computational cross section going upstream from the dam. Comparison of the computed grain size distributions within the delta deposits with measurements from other reservoirs in the Transverse Mountain Range in Southern California shows good correlation with respect to total amount, size and distribution.

The results of this study represent the best estimate of the extent and character of reservoir delta sediment materials. The distribution of sediment in a reservoir depends upon many factors, especially the reservoir operating policy, details of which are currently unknown. Further evaluation of these results may be warranted during the dam's design with a view toward minimizing or mitigating the impact of sediment deposition in the reservoir area.

INTRODUCTION

A serious flood hazard exists within the rapidly developing urban areas of Orange, Riverside, and San Bernardino counties. Without expanded flood protection along the Santa Ana River, future floods could cause an estimated 9.15 million dollars in damage and jeopardize the safety of approximately two million residents living in or along the flood plain (US Army Corps of Engineers, 1980).

The problems along the main stem of the Santa Ana River were initially studied in May of 1964. A preliminary survey report was completed by the Los Angeles District in 1975 (US Army Corps of Engineers, 1975). It summarized plans for alleviating the potentially catastrophic flooding problems, in addition to other issues such as water conservation, recreation, and environmental quality needs. The plans set forth in the Survey Report were studied in greater depth, culminating in the "Santa Ana River Phase I GDM" (US Army Corps of Engineers, 1980). This report outlined nine elements of an overall flood protection plan to provide Standard Project Flood (SPF) protection for the Santa Ana River and flood plain. One of the first elements within the overall plan calls for the construction of a flood storage retention dam in San Bernardino County near the communities of Mentone and East Highlands.

The primary purpose of the Mentone Dam would be to collect and retain floodwaters from Big Bear Lake, the Upper Santa Ana River, Mill Creek, Oak Creek and Plunge Creek. Peak SPF floodflows of up to 126,000 cubic feet per second would be reduced to 6,000 cubic feet per second as they pass through the Mentone Dam outlet works (US Army Corps of Engineers, 1980).

The purpose of this investigation was to analyze the sedimentation characteristics of the Mentone Dam. The following general tasks were performed to accomplish this goal:

- (1) Identify major physical, climatological, and geologic factors affecting erosion and yield of sediment within the study area.
- (2) Quantify total erosion and sediment yield for various hydrologic conditions.
- (3) Estimate the extent, shape and character of sediment deltas likely to form within the reservoir.

Based on the results from these tasks, the Los Angeles District conducted detailed groundwater modeling and geotechnical investigations in order to evaluate the effects that sediment deposition may have on infiltration rates and overall groundwater recharge in the study area. Further details of these investigations are presented elsewhere in this report.

DESCRIPTION OF STUDY AREA

The Santa Ana River flows approximately one hundred miles from its headwaters in the San Bernardino Mountains before emptying into the Pacific Ocean just northwest of Newport Beach (see Figure 1). The overall drainage area of the Santa Ana River Basin is approximately 3200 square miles. It is the largest and most diverse river system in southern California. The most important basin characteristics to consider in this investigation are geologic and hydrologic.

Geology

The geology of the Santa Ana River Basin is diversified and complex. The overall region is composed primarily of crystalline and sedimentary rocks in the upper valleys and mountains with alluvial sediments throughout the valley floor. The San Bernardino Mountains are derived from several varieties of igneous and metamorphic rocks: mostly quartz, quartz monzonite, diorite, and some schists and gneiss. Rock and soil materials, eroded from the higher areas, have deposited at the base of the mountains to form the San Bernardino Valley floor. The combined outwash fans of the Santa Ana River and Mill Creek are the largest in the valley. This alluvial fill was deposited over the last 10 million years and is located near the proposed Mentone damsite. It consists of boulders, gravels and sands with smaller amounts of silts and clays. These sediments also make up portions of the groundwater aquifer in the Santa Ana River Basin.

Alluvium deposits over 1000 feet deep are found in the middle and upper portions of the basin. These widely graded materials have high permeabilities and are excellent aquifer materials. Some of the highest infiltration and groundwater recharge rates in California are found along the Santa Ana River. Concern for possible reduction in groundwater recharge as a result of constructing the Mentone Dam led to this investigation.

Hydrology

The climate in the San Bernardino Valley is typically mild, with long, hot, dry summers and short, cool winters with light precipitation. Rainfall is usually low and highly seasonal with most of the precipitation occurring between December and March. The average annual rainfall is approximately 14 inches in Redlands and 16 inches in San Bernardino.

Flooding is a severe problem in the study area even though the climate is relatively dry. The Santa Ana River and other creeks that drain into the valley receive runoff from large and very steep upper watersheds where annual precipitation often exceeds 45 to 50 inches.

Historically, the Santa Ana River flowed perennially. Today, however, the river is ephemeral throughout most of its length because of various man-induced controls and demands for water. Streamflows from the upper

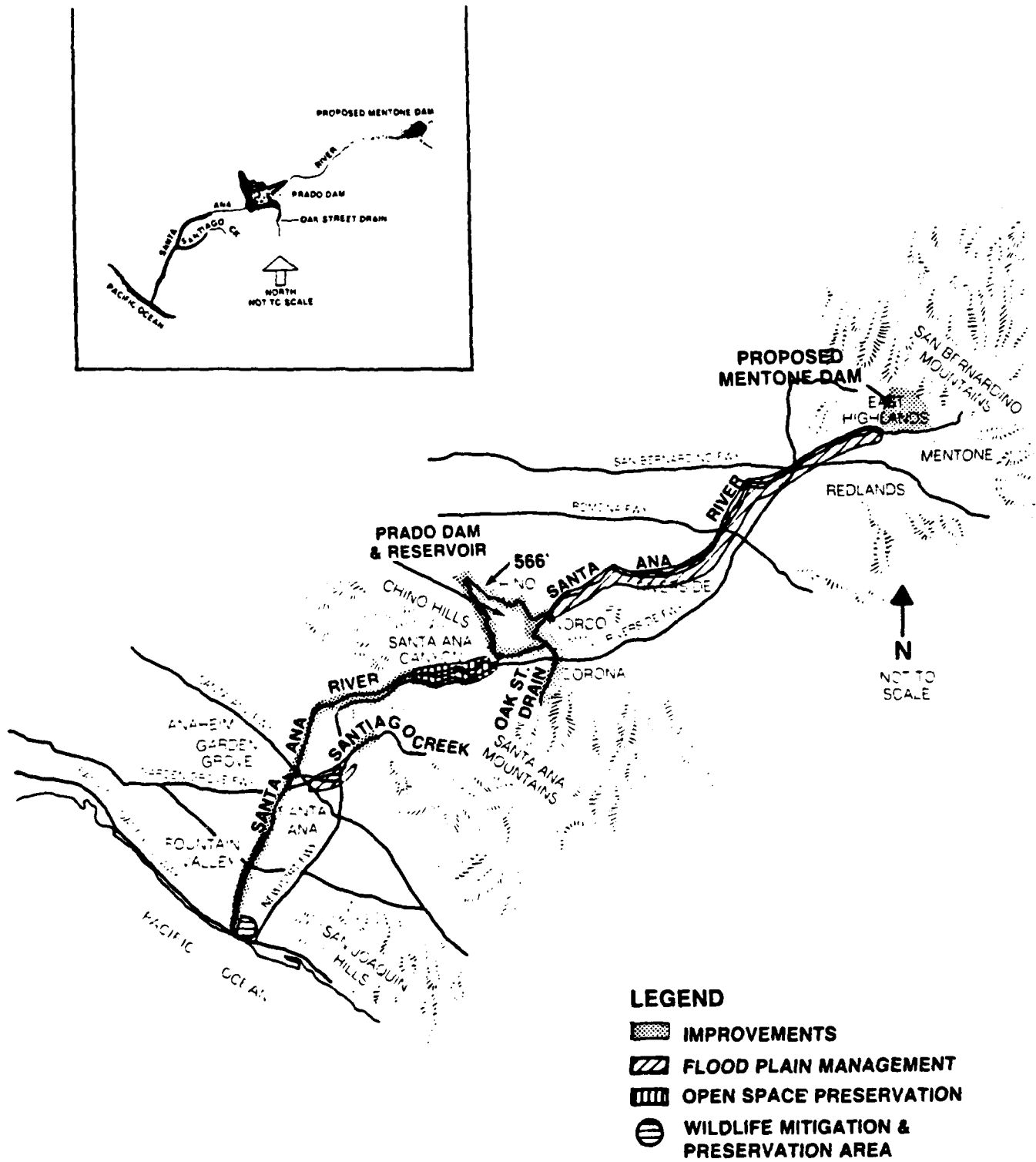

Figure 1. LOCATION MAP

drainages increase rapidly during large storms due to the characteristics of the watershed and steep river gradients. Such conditions, along with high rainfall intensities, often result in flash floods with sharp peaks and short durations.

Mentone Dam

Construction of the proposed Mentone Dam (see Figure 1) is only one aspect of the overall Santa Ana River flood control project. The purpose of the dam will be to store runoff from the Upper Santa Ana River, Bear, Plunge and Mill Creeks. Potential floodwater would be detained 4 to 6 days until the high water level at Prado Reservoir is reduced. Slow release from Mentone Dam would distribute the flow over time and lessen the risk of downstream flooding.

The proposed Mentone Dam would be located between the towns of Mentone and East Highlands near the confluence of Mill Creek and the Santa Ana River. As shown in Figure 2, it would be a horseshoe-shaped earthfill dam with a crest length of about three and one half miles. At its middle portion, its crest would be 230 feet above the riverbed with a top width of 70 feet and a base width of 2700 feet (US Army Corps of Engineers, 1980). The existing Mill Creek levee would be improved and extended farther upstream along Mill Creek to prevent floodwaters from entering the cities of Mentone or eastern Redlands. The reservoir would have a net capacity of 151,000 acre-feet and an area of about 1,800 acres. Retention time for impounded floodwaters would be approximately 3 weeks or less.

Table 1 summarizes some of the pertinent physical and hydrologic characteristics of the Mentone Dam. Details of the design and operation of the Mentone Dam and Reservoir are presented in the "Santa Ana River Phase I GDM" (US Army Corps of Engineers, 1980).

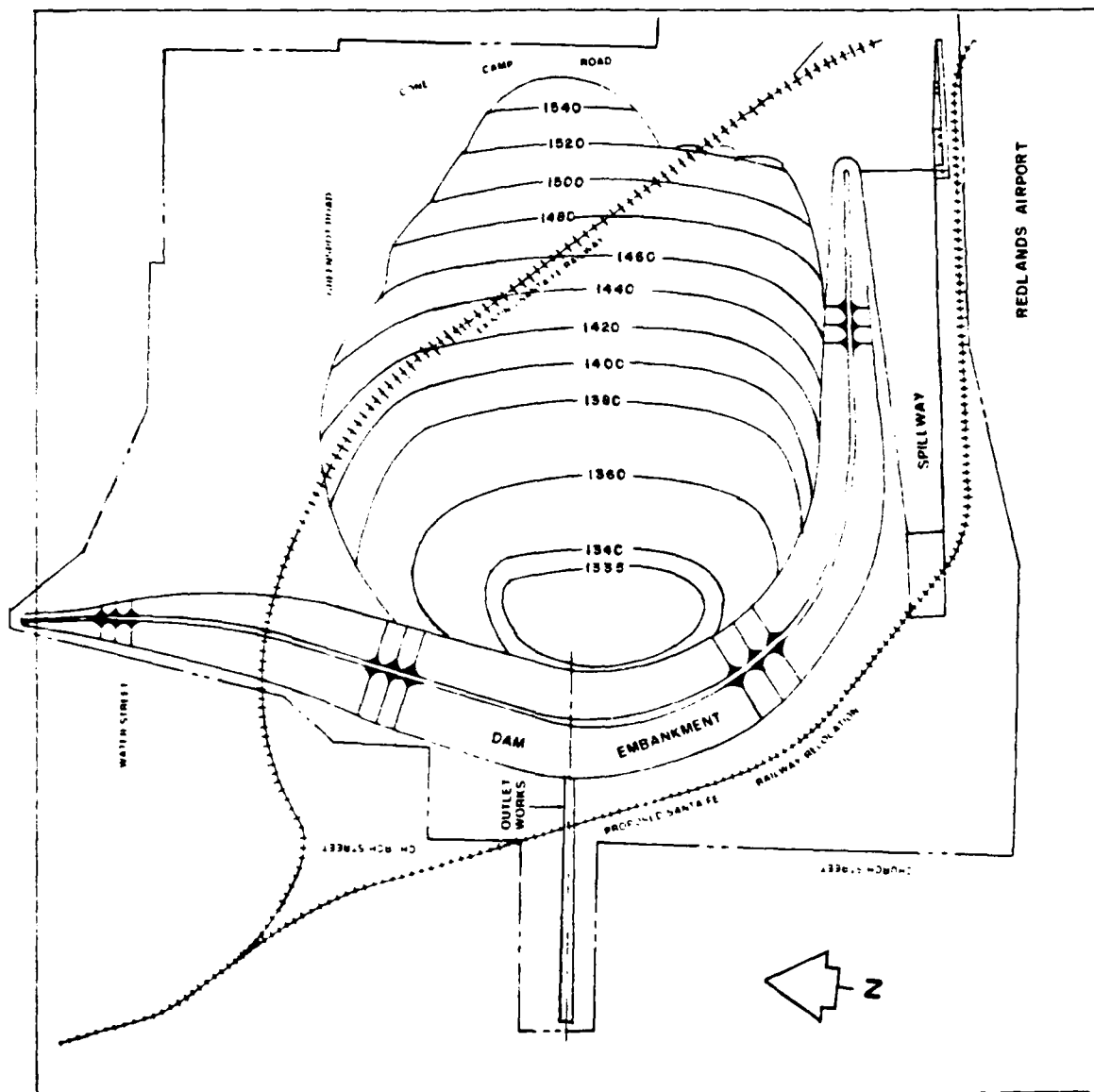

Figure 2. SKETCH OF PROPOSED MENTONE DAM

TABLE 1

Characteristics of the Mentone Dam
 (from "All River Plan", Phase I GDM:
 U.S. Army Corps of Engineers, 1980)

| | | |
|---|---------|---------|
| Drainage area | 260 | sq mi |
| Dam (rolled earthfill) | | |
| Crest Elevation | 1,573.5 | ft msl |
| Maximum height above streambed | 226 | ft |
| Crest length | 17,700 | ft |
| Freeboard | 8 | ft |
| Spillway (overflow, concrete) | | |
| Crest elevation | 1,548.5 | ft msl |
| Crest length | 1,000 | ft |
| Elevation of maximum water surface | 1,565.5 | ft msl |
| Outlet works (gated conduit) | | |
| Diameter of conduit | 14 | ft |
| Length of conduit | 1,373 | ft |
| Intake elevation | 1,335 | ft msl |
| Reservoir | | |
| Area at spillway crest | 1,167 | acre |
| Capacity (gross) at spillway | 181,500 | acre-ft |
| Storage allocation below spillway crest | | |
| Flood control | 144,500 | acre-ft |
| Sedimentation (100-year storage) | 37,000 | acre-ft |
| Standard-project flood | | |
| Total volume (4 days) | 160,000 | acre-ft |
| Peak inflow | 126,000 | cfs |
| Peak outflow | 6,000 | cfs |
| Probable maximum flood | | |
| Total volume | 508,200 | acre-ft |
| Peak inflow | 265,000 | cfs |
| Peak outflow | 256,000 | cfs |

EROSION AND SEDIMENT YIELD*

Factors Affecting Erosion and Sediment Yield

The amount of erosion in a watershed and the amount of sediment transported or deposited in a stream or reservoir are the result of the interaction of two groups of variables. The first group contains those variables which influence the quantity of material eroded at a specific location in the drainage basin. Within the first group of variables are two major categories of factors affecting rates of sediment production from watersheds. They are: (1) climatic factors such as precipitation, temperature and winds, and (2) watershed characteristics such as past fire effects, size of the drainage area, topography, degree of channelization, soils, and plant cover conditions. The second group contains variables which directly influence the sediment transporting capacity of the drainage area. This group includes the geometric, hydraulic and sediment material characteristics of streams or conveyance channels in the basin.

Generally, for a given watershed, the rate of sediment yield per unit area decreases as the size of the drainage area increases. However, in mountainous regions such as the Upper Santa Ana, there may be little difference in sediment yield per unit area due to the size of the drainage area. More important watershed characteristics are: (1) accelerated geological activities such as earthquakes, uplifting, mass wasting and exfoliation, (2) combined land-use impacts from agriculture, urbanization, construction, and off-road recreation, and (3) periodic forest and brush fires.

The single-most important factor affecting erosion and sediment yield in the Upper Santa Ana River Basin is the occurrence of fires. Removal of protective vegetation by fire greatly increases rainfall runoff and subsequently, rates of erosion and yield. Erosion will continue at greater than normal rates from the time the watershed is burned until it has recovered.

* To avoid confusion, it is essential to define some of the terms referred to in this report. "Erosion" includes both removal and transportation of eroded materials in the study area. The units for erosion are usually weight (in tons) per unit of area and time. "Sediment yield" is equal to the net sediment discharge (gross erosion minus amount deposited along the way) from a drainage area. Units for sediment yield are usually a volume (either acre-feet or cubic yards) per unit area (square miles) per unit time (years). For this study sediment yield will be equivalent to the volume of sediment expected to arrive at the Mentone Reservoir site per unit drainage area and time. Not all of the eroded material is effectively sluiced through a river system and delivered to the point of interest (in this case the Mentone Reservoir). The bulk of the eroded sediment may deposit at intermediate locations wherever the entraining runoff waters are insufficient to sustain transport. "Sediment load" refers to the weight of sediment in tons per day being transported by major water courses such as the Santa Ana River.

The return of vegetation in a watershed will provide varying degrees of erosion protection. Minimum protection will occur immediately after the fire. A maximum, and relatively constant resistance to erosion, will occur once normal vegetative cover has returned completely. Recovery from a complete burn may take from three to twenty years, depending on the characteristics of the original vegetation, severity of the burn, and size of the subbasin (Rowe et al. 1949 and 1954). Figure 3 illustrates conceptually the effects of fire on sediment erosion and yield from a watershed. When portions of a watershed burn, then the areal extent of the burn becomes an additional factor to consider. State and county agencies keep records, or "fire histories", of the dates, extent and severity of past fires (Taylor, 1979).

Because of the overriding effect of fire on runoff and erosion rates in the Santa Ana River Basin, fire effects will be discussed in further detail.

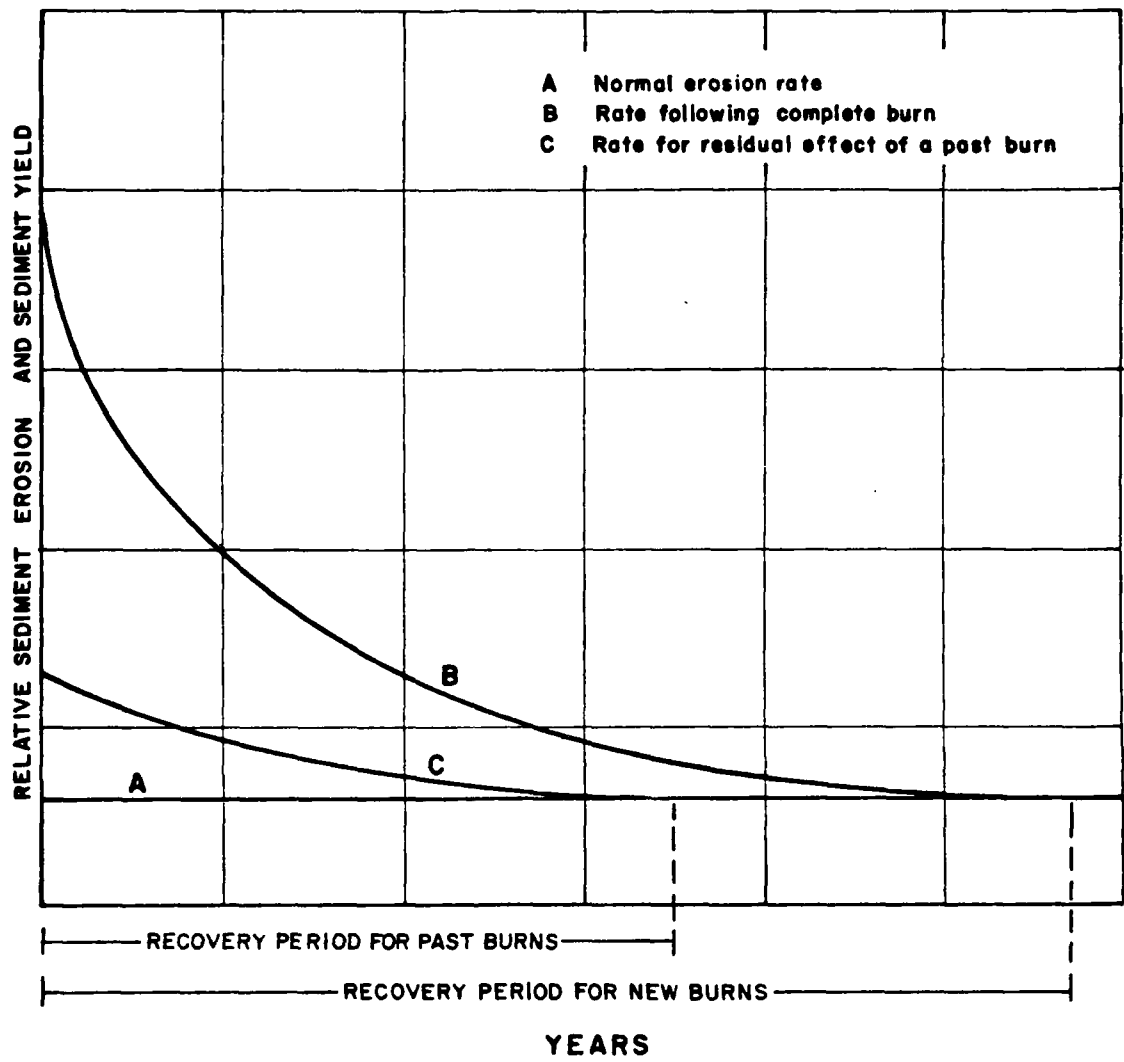

Figure 3. EFFECT OF FOREST FIRE FREQUENCY ON SEDIMENT EROSION AND YIELD IN A TYPICAL WATERSHED

(FROM ROWE, COUNTRYMAN, AND STOREY, 1954)

Effects of Fire on Peak Discharge

The frequency and magnitude of peak runoff flows along with corresponding erosion rates determine the amount of sediment produced within a given watershed. If the relationship between peak discharge and yield is known for a subbasin, then computation of sediment yield is dependent upon the following six factors (Rowe et al. 1954):

1. The frequency and magnitude of normal runoff and peak discharges from the unburned watershed.
2. The effect of fire on changing the magnitudes of normal flows and peak discharges.
3. Residual effects of past fires on runoff flows.
4. Normal annual erosion rates.
5. Effect of fire on erosion rates.
6. Residual effects of fire on erosion rates.

Rowe et al. (1954), investigated over 256 watersheds in southern California. The study area covered approximately 6,800 square miles where extensive precipitation and streamflow data were available. Instantaneous peak discharge for a storm was established as the basic measure of watershed discharge. Rowe et al. (1954), examined streamflow records and found that peak discharge is particularly sensitive to fire effects. They also found peak discharge to be the best indicator of watershed performance with respect to erosion and yield for the types of watersheds found in Southern California.

Rowe et al. (1954), selected key watersheds within five different storm zones in the study area. Reliable precipitation and runoff data for at least 60 years of record were available for the key watersheds within each storm zone. The key watersheds also had the most representative physiographic characteristics among the watersheds in each storm zone.

The frequency and magnitude of normal peak discharges were developed for key watersheds that had no previous fire damage. Precipitation and runoff data for recently burned watersheds were then compared to data collected for the same watershed prior to the burns in order to determine the effects of fire on the magnitudes of flow and peak discharge. Residual effects of past fires on runoff and peak discharge were determined by analyzing historical data for watersheds at various stages of recovery after burns occurred.

Rowe et al. (1954), established relationships between peak discharge frequencies and fire effects for all of the subbasins and watersheds in their study area. Relationships for the six contributing subbasins above Mentone are included in the Appendix.

Effects of Fire on Sediment Yield

Annual erosion rates and sediment yields must be determined for unburned watershed conditions before fire effects can be determined. Annual erosion rates and watershed sediment yield are best determined from measurements of sediment accumulation in reservoirs and sedimentation basins situated in watersheds having natural vegetative cover. As with peak discharge, it is important to evaluate key watersheds that are representative of a particular storm zone or physiographic area. Sediment yield is determined from the total volume of sediment trapped in the reservoir over time (Yield = accumulated sediment volume/years/area of the watershed). Next, the total volume of sediment is distributed to individual peak discharges from events that occurred during the period of accumulation.

Several methods for distributing the sediment to the peak discharge can be used. Rowe et al. (1954), used a method developed by Gibson (1952). This method distributed measured sediment volumes to individual peak discharges in proportion to the fifth power of the representative channel velocity of flow entering the reservoir. This computation was repeated for each key watershed to produce a table of the following values: peak discharge, representative channel velocity during the peak discharge, velocity to the fifth power, percentage of the total cumulative discharge, and the distributed sediment yield in cubic yards per square mile of drainage area. Tables of these values developed for the Los Angeles Basin and Transverse Mountain Range are given by Rowe et al. (1954). The distributed sediment yield values were plotted against the corresponding unit peak discharges on log-log paper, (e.g., Figure 4) for each key watershed in the Angeles storm zone.

Peak discharge versus erosion curves similar to that in Figure 4 were developed by Rowe for several watersheds throughout each storm zone. These curves showed little variation when superimposed on each other. Therefore, a single average curve was developed to represent the average relationship between peak discharge and erosion for all the watersheds within the storm zone. This average curve was essentially the same as the curve presented in Figure 4.

Next, Rowe et al. (1954) computed the average erosion for each individual watershed in the storm zone assuming unburned conditions. They used the peak discharge versus erosion curve from Figure 4, and the individual watershed's peak discharge frequency curve.

To evaluate the effects of fire, they used records of sediment accumulation in debris basins situated in watersheds that were completely burned in 1930. They determined the weighted average annual erosion rate for each year from the time of complete burn to recovery of the watershed. Using the methods described earlier, they distributed the annual sediment volume by peak discharge for each year of recovery following a complete burn. Smooth curves were developed for representative watersheds in each storm zone. Figure 5 is the set of erosion versus peak discharge curves which were adopted for the present Mentone Damsite study.

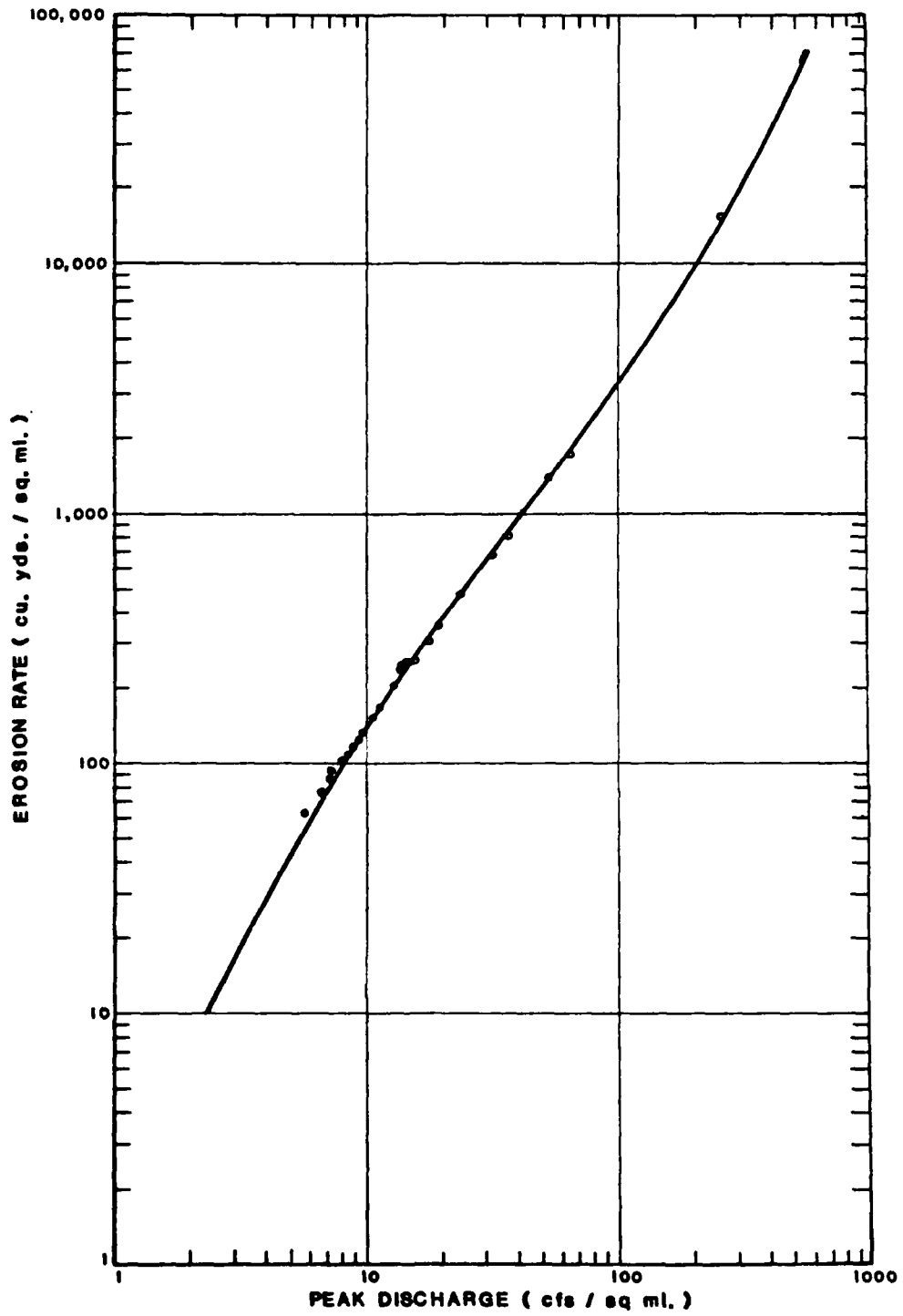

Figure 4. RELATIONSHIP OF EROSION RATES AND NORMAL PEAK DISCHARGE (from Rowe, Countryman, and Storey, 1954)

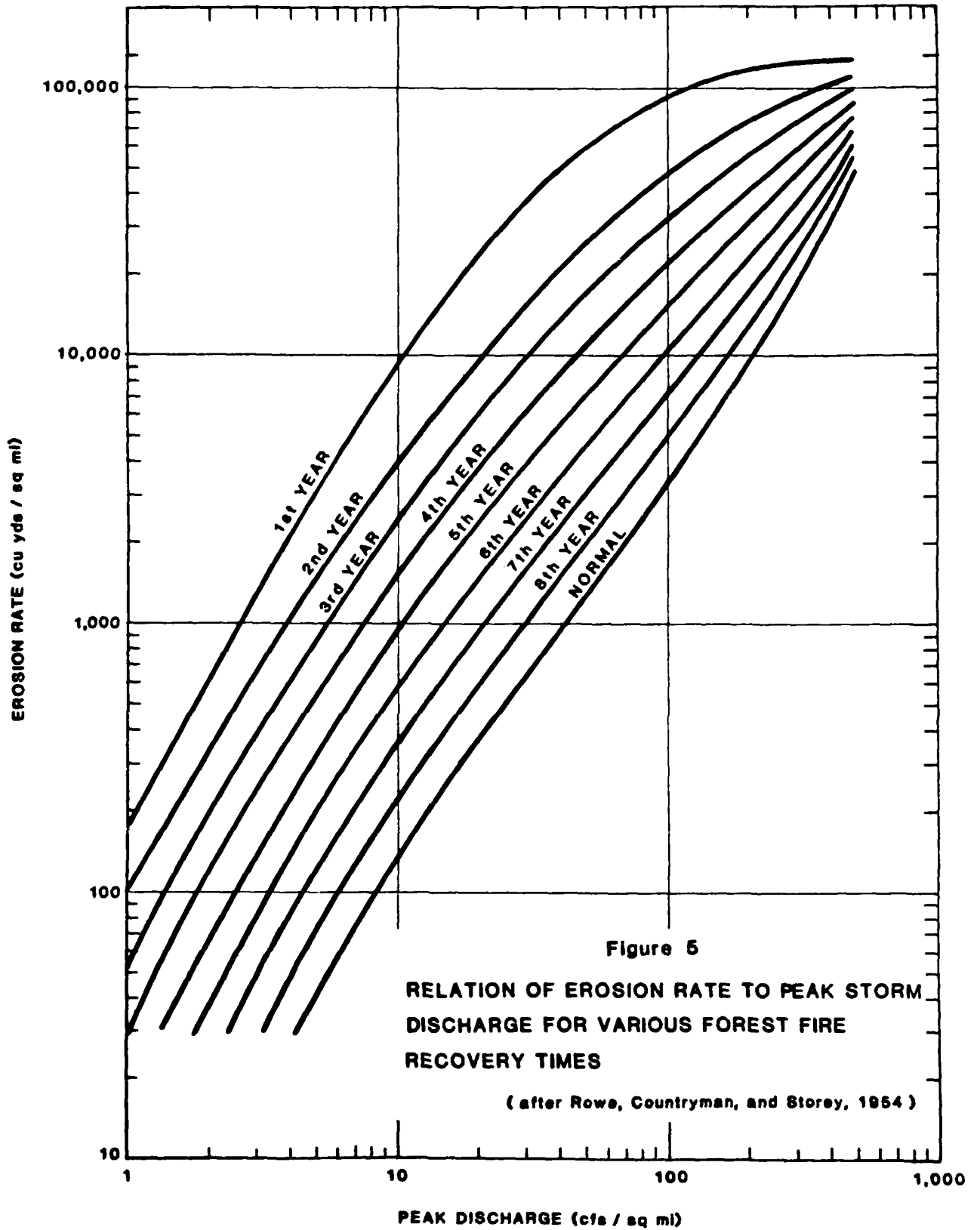

Figure 5

RELATION OF EROSION RATE TO PEAK STORM
DISCHARGE FOR VARIOUS FOREST FIRE
RECOVERY TIMES

(after Rowe, Countryman, and Storey, 1954)

For watersheds that are only partially burned during a fire, it is assumed that the burned portion will erode at the same rate per square mile as if the entire watershed had burned. The unburned portion of the watershed would, therefore, erode at the normal unburned rate per square mile. This assumption provides the mechanism for estimating increases in erosion and sediment yield from watersheds that are partially damaged during a fire.

The following equation was suggested by Rowe et al. (1954), to compute erosion rates following partial burns.

$$E_x = (E_b - E_n) (A_x / A_b) + E_n$$

where E_x = Erosion rate for a given year after a partial burn.

E_b = Estimated erosion rate for a complete burn for a given year (Figure 5).

E_n = The normal unburned watershed erosion rate.

A_x = Percentage of the total watershed area burned.

A_b = Percentage of the total watershed that is burnable.

For watersheds recovering from several partial burns, $(E_b - E_n)(A_x / A_b)$ was computed for each burn and the sum of these values was used to compute the average erosion rate.

This discussion of the method for computing the effect of past fires on erosion rates completes the tasks necessary for determining fire effects on peak discharge and erosion. The following sections will discuss ways in which these methods were applied to evaluate the sediment yield characteristics for the six subbasins above the Mentone damsite.

SEDIMENT YIELD TO MENTONE DAMSITE

Contributing Watersheds

In order to evaluate sediment sources and sediment yield to the proposed Mentone Damsite, the total drainage basin was divided into six subbasins. Each subbasin was then examined individually according to its physiographic character, geology, soil type, hydrology and fire history. Runoff and sediment contribution to the project site from each subbasin was determined.

The total drainage area above the Mentone damsite is approximately 260 square miles. Big Bear Lake and Dam control about 40 square miles of drainage. There are also other small areas within the basin which are locally controlled. Locally controlled drainages were not considered as part of the effective area for the development of the total sediment budget. Therefore, the total effective drainage area for sediment erosion and yield is approximately 210 square miles.

Figure 6 is a schematic diagram of the Upper Santa Ana River Basin and its six watersheds. Soil surveys by Retelas (1980) and the U.S. Department of Agriculture, Soil Conservation Service (1980) provided the necessary information to determine the dominant soil types within each subbasin. The percentage of each major soil type in each subbasin's effective drainage area was estimated, and representative soil characteristics and erosion potential were determined for each subbasin using these data.

Hydrologic and Watershed Burn Conditions

Three different hydrologic conditions were considered: (1) a typical two-year storm, hereafter referred to as the mean annual flood (MAF), (2) the Standard Project Flood (SPF) and (3) fifty successive events of the of mean annual flood. The Los Angeles District provided hydrologic data from past events along with their criteria for the SPF (U.S. Army Corps of Engineers, 1980). Single event simulations were performed for the two-year and SPF events in order to bracket a wide range of possible event impacts. The SPF represents the flood that would result from the most severe combination of meteorologic and hydrologic conditions considered reasonably characteristic of the geographical area. The SPF is normally larger than any recorded flood in the area. Fifty successive years of mean annual flood flows were used to estimate long-term project performance. Gated reservoir operation was assumed. Details of the hydrologic characteristics of these events are presented in the hydrology section of the "Santa Ana River Phase I GDM" (US Army Corps of Engineers, 1980).

The extent and frequency of fires directly affects the amount of runoff and sediment yield from a watershed. Two different forest conditions based on forest fire histories were used to develop the peak discharge and erosion rates from each of the six subbasins. "Current burn" forest conditions were based on what currently exists throughout each subbasin with respect to the extent and dates of past forest fires. Details of the current forest conditions and past fire histories were obtained from the U.S. Forest Service (1982) and the San Bernardino Flood Control District Fire Statistics (1980).

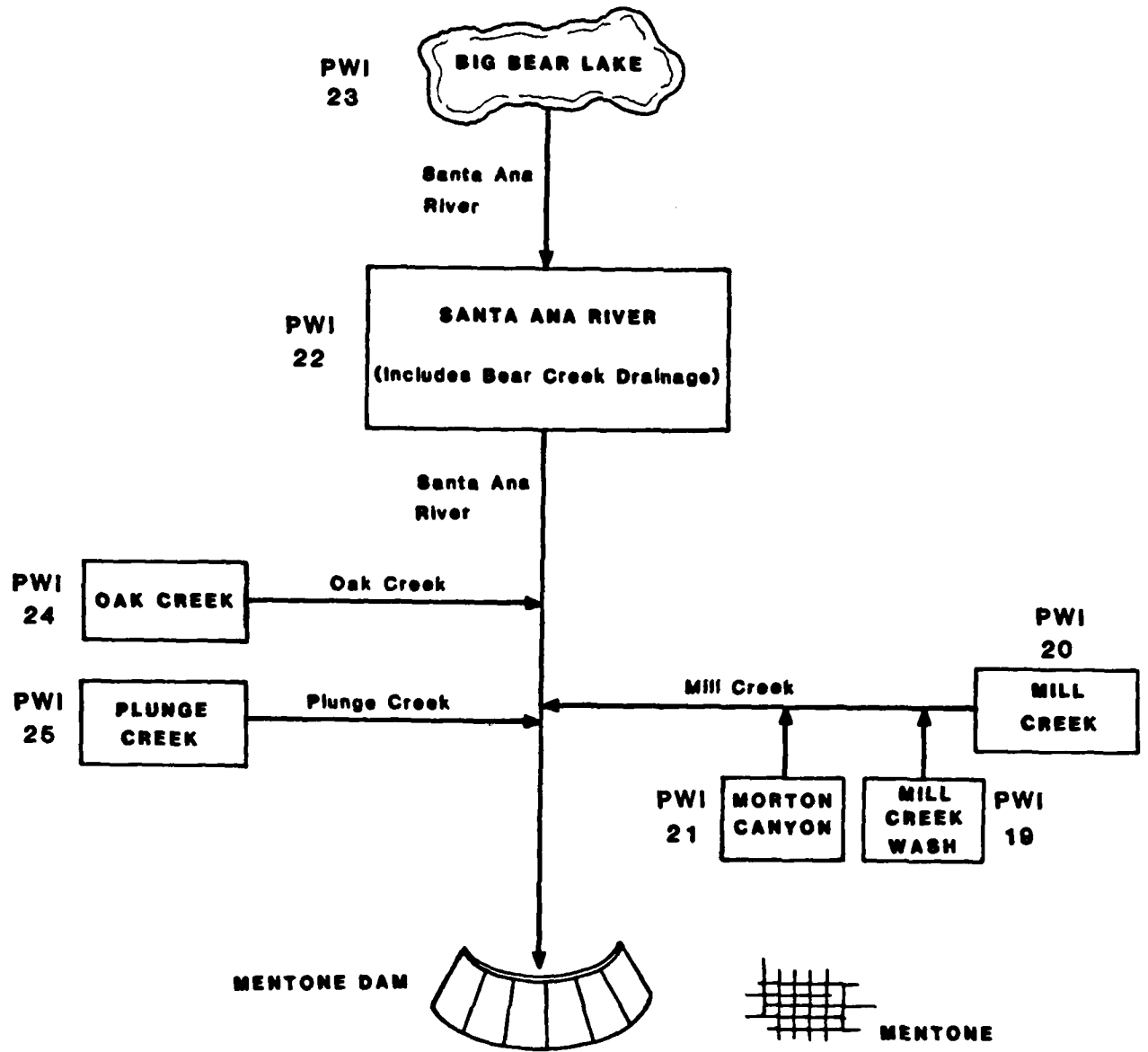

PWI = National Forest Service LD. Numbers for "Project Work Inventory" Watersheds.
 They Delineate the Forest into Separate Watersheds with Unique
 Hydrologic Characteristics and Burn Histories.

Figure 6

Runoff and Sediment Contributing Watersheds for the Santa Ana River
 at the Mentone Dam site

A hypothetical "reasonable maximum burn" (RMB) condition was developed to depict the worst erosion condition that could occur due to forest fires. Development of this condition was closely coordinated with recommendations from personnel from the U.S. Forest Service in San Bernardino, California. The RMB forest condition was based on the amount and types of burnable materials within each watershed and on other important factors such as worst possible wind conditions. The resulting reasonable maximum burn conditions also assume that the burn has been recent and that there has been no time for forest recovery.

Analysis of the combination of the two hydrologic extremes (two-year event and SPF) with the two forest-burn conditions provided a means for developing a broad range of possible sediment yields from each contributing subbasin. The methods used for estimating sediment yield from each subbasin follow.

Current Burn Average Annual Sediment Production. Table 2 presents the estimated average annual sediment production rates for each of the contributing watersheds from Big Bear Lake to Mentone. Sediment production is the total estimated erosion times the watershed delivery ratio (see U.S. Department of Agriculture, SCS, 1971) equalling the total cubic yards of sediment delivered or produced by an event. Values presented in Table 2 are based on current burn forest conditions that existed throughout the drainage basin as of fall, 1982. Average annual sediment production and yield were developed from the data compiled by Rowe et al. (1954), for each individual subbasin.

Appendix A lists the peak discharge rates and annual sediment erosion rates following burning for each of the six subbasins contributing sediment to the Mentone Dam site. These data were used to develop the estimated current burn sediment production rates summarized in Table 2. Sediment production and yield were adjusted upward to reflect current burn forest conditions using fire history maps.

U.S. Forest Service fire history maps were studied to determine dates of past fires and the percentages of each subbasin that were burned. Column 4 in Table 2 lists the subbasin drainage area and column 5 lists the year past fires occurred and the percentage of the subbasin area that was burned. A burn adjustment factor was determined for each burned area depending on how long the area had been recovering from past fires. If an area had burned more than ten years previously, it was considered to be completely recovered, and therefore, had a burn adjustment factor of one. Subbasin areas burned more recently had burn adjustment factors greater than one (see column 6, Table 2). Column 7 lists the estimated average annual sediment production rate for each subbasin for normal unburned watershed conditions.

Adjusted production rates (column 8) are obtained by summing the products of the percentages of previously burned areas and their associated burn adjustments factors times the normal watershed production rates. The sum of the volumes of sediment from each subbasin (approximately 433×10^3 cu. yds/yr) represents the total average annual sediment production from the drainage basin above Mentone for

Table 2
Estimated Sediment Production Rates for Watersheds Contributing Sediment
to the Proposed Mentone Dam Site Under Current Burn Watershed Conditions (1)

| Watershed (2) Number | PVI (2) Number | 70-yr Mean Ann. Prec. (inches) | Area of Watershed (sq. mi.) | Watershed (1) Burn Hist. (Fire yr/watershed) | Adjusted Burn Factor for Current Fire Damage (Dimensionless) | Est. Ave. Ann. Sed. Prod. for Normal Watershed Conditions (cu. yds/sq. mi./yr) x 10 ³ | Ave. Ann. Sed. Prod. Adjusted for Current Burn Conditions (cu. yds/yr) x 10 ³ | Adjusted Ave. Ann. Yield to Mentone Dam Site AF/sq. mi./yr |
|----------------------|----------------|--------------------------------|-----------------------------|--|--|--|--|--|
| 1 | 2 | 3 | 4 | 5 | 6 | 7 | 8 | 9 |
| Big Bear (8) Lake | 23 | 24.8 | 76 (8) | 1973/02 | 2.4 | 0.42 | 16.41 (8) | 0.27 (8) |
| Santa Ana River | 22 | 32.9 | 140.0 | 1970/45, 1979/05 | 1.0, 4.4 | 1.39 | 227.68 | 1.01 |
| Plunge Creek | 25 | 34.8 | 16.9 | 1970/90 | 1.0 | 3.64 | 61.52 | 2.26 |
| Mill Creek | 20 | 34.1 | 43.2 | 1970/10 | 1.0 | 1.42 | 61.34 | 0.88 |
| Morton Canyon | 21 | 21.9 | 2.5 | 1979/60 | 7.9 | 3.60 | 46.26 | 11.47 |
| Mill Creek Wash | 19 | 21.8 | 4.3 | 1970/75, 1979/10 | 7.2 | 3.78 | 26.32 | 3.80 |
| Oak Creek | 24 | 22.9 | 3.7 | 1970/35, 1979/10 | 6.8 | 1.75 | 10.23 | 1.71 |
| | | | | | | | (8) 433.36 x 10 ³ (cu. yds/yr) | (8) 1.28 AF/mi ² /yr. |

(1) Estimated values presented herein have been developed for current forest and watershed conditions and reflect effects due to past forest fires.

(2) Watershed names and PVI numbers are shown on Figure 1.

(3) From San Bernardino National Forest Service fire history maps.

(4) The Burn factor (dimensionless) represents the increased relative magnitude in sediment production for a specific watershed based on the number of recovery years since the last fire occurred. Normal forest conditions are assumed after 10 years of recovery time.

(5) Amount of sediment production that would be produced if the entire forest and watershed were unaffected by previous fire damage.

(6) Adjusted sediment production to reflect increased sediment production rates from fire-damaged watersheds.

(7) Assumes that the average dry density of the material is 95 lbs/ft³.

(8) Although discharging flows from Big Bear Lake contribute to the total flow entering the Santa Ana River, it is assumed that all of the sediment produced from the Big Bear Lake watershed is trapped in the lake. Therefore, sediment production and yield from the Big Bear Lake Watershed were not included in the totals or basin averages.

current burn watershed conditions. This production rate produces a basin-wide average annual sediment yield of approximately 1.3 acre-feet per square mile per year for current burn conditions.

No measured sedimentation or yield data exist for reservoirs or the watersheds in the immediate vicinity of the Mentone site. However, the U.S. Department of Agriculture's Miscellaneous Publication No. 1266 (1970), entitled "Summary of Reservoir Sediment Deposition Surveys Made in the United States" gives sediment deposition data for several reservoirs located in San Gabriel Mountains just west of the study area. A summary of these data is presented in Table 3. Hansen, Big Tujunga, Devil's Gate and Pacoima reservoirs all have similar drainage basins and should be grouped together (referred to as Group 1). Cogswell Dam and the San Gabriel System can be considered as a second group with different basin conditions. The characteristics of the Mentone drainage are very similar to the Group 1 reservoirs. Cogswell and the San Gabriel System have different precipitation and basin characteristics and different burn histories than do Group 1 basins. Therefore, the Group 2 basins have greater sediment yields than Group 1. The Hansen Reservoir drainage is very similar to the Santa Ana River Basin at Mentone Reservoir and the observed yield from the Hansen is similar to the current burn yield estimated for the Mentone site.

The Hansen drainage area is about one third less than that of the drainage area above the Mentone dam site and, therefore, has a larger delivery ratio. Adjusting the estimated sediment yield for the Mentone by the ratio of the Hansen delivery ratio to that of the Mentone gives approximately the same yield (1.43 AF/sq.mi./yr) as that observed for the Hansen Reservoir (1.44 AF/sq. mi./yr). This indicates that the estimated average annual sediment production and yield for the Mentone Dam under current burn conditions is quite reasonable.

Reasonable Maximum Burn Average Annual Sediment Production. Table 4 summarizes the average annual sediment production and yield for reasonable maximum burn watershed conditions in the Upper Santa Ana River drainage basin. As previously mentioned, reasonable maximum burn conditions depict the worst erosion conditions that could occur due to forest fires. As shown in column three of Table 4, it is assumed that fifty percent of the Santa Ana and Mill Creek subbasins would burn and one hundred percent of the four other subbasins would burn during a reasonable maximum burn.

Reasonable maximum burn (RMB) sediment production was determined in the same manner as current burn (CB) production. Data from Appendix A were used to determine the average annual sediment production for each subbasin assuming that each had been burned less than one year previously. With RMB conditions, the average annual sediment production is approximately 5,390,000 cu.yds/yr. This is based on the assumption that all of the sediment delivered to the Santa Ana River from contributing watersheds continues through the system until it reaches the proposed Mentone dam site.

This represents basinwide weighted average annual sediment yields of 1.28 acre-feet per square mile per year for current burn conditions and 15.9 acre-feet per square mile per year for reasonable maximum burn conditions. Thus, the RMB yield is approximately twelve times the CB yield. This is consistent with observations for similar watersheds that have been completely burned (Rowe et al. 1954; Brown, 1972 and Wells, 1981).

Table 3

Sedimentation Data for Reservoirs Located in the San Gabriel Mountains
(data from USDA Misc. Paper 1266)

| Reservoir Name | Net Drainage Area (sq. mi.) | Est. Delivery Ratio ⁽¹⁾ (dimensionless) | Vol. of Sed. Accumulated (AF) | No. of Years of Record (yrs) | Avg. Ann. Sed. Yield (AF/sq.mi./yr) |
|---|-----------------------------|--|-------------------------------|------------------------------|-------------------------------------|
| Hansen | 146.0 | 8.4 | 6,100 | 29 | 1.44 |
| Big Tujunga | 82.2 | 9.8 | 3,779 | 38 | 1.20 |
| Devil's Gate | 31.7 | 13.5 | 2,981 | 49.5 | 1.90 |
| Pacoima | 28.2 | 14.0 | 2,291 | 39.5 | 2.06 |
| Cogswell | 39.0 | 12.5 | 3,542 | 34 | 2.67 |
| Total San Gabriel System ⁽²⁾ | 210.7 | 7.5 | 21,026 | 37.1 | 2.69 |
| Estimated for Mentone ⁽³⁾ | 210.5 | 7.5 | No measurements | None | 1.28 |

(1) Delivery Ratios are based on USDA sediment delivery vs. size of drainage basin (USDA, SCS, 1971).

(2) Includes Cogswell Dam, San Gabriel Dam and Morris Dam.

(3) There are no observed data for the Mentone area. This yield is based on current burn watershed conditions estimated in this study (see Table 2).

Table 4
 Estimated Sediment Production for Reasonable Maximum Burn Conditions
 Due to Average Annual Precipitation Occurring on All Watersheds
 With Less than One Year of Reforestation Recovery Time

| Watershed (1) | Area (mi ²) (2) | Assumed Reasonable Max. Burn Conditions (3) | Adjusted Burn Factor (4) | 100% Burn Sediment Production Rate (cu. yd./sq. mi./yr) x 10 ³ (5) | Reasonable Max. Sediment Prod. (with < 1 year Recovery Time) (cu yds/yr) x 10 ³ (6) | Adjusted Reasonable Max Sed Yield (AP/Sq. mi/yr) (7) |
|-----------------------------|-----------------------------------|---|-----------------------------|--|---|--|
| Santa Ana | 140 | 1982/50 | 18 | 25.02 | 3848.7 | 81.2 |
| Plunge Creek | 16.9 | 1982/100 | 29.8 | 108.67 | 1833.14 | 67.2 |
| Mill Creek | 43.2 | 1982/50 | 21.4 | 70.39 | 687.1 | 9.9 |
| Norton Canyon | 2.5 | 1982/100 | 35 | 126.0 | 315. | 78.1 |
| Mill Creek Wash | 4.3 | 1982/100 | 32.1 | 119.65 | 513.64 | 74.0 |
| Oak Creek | 3.7 | 1982/100 | 29.8 | 52.15 | 192.96 | 32.3 |
| Basin-Wide Weighted Average | | | | | 5.39 x 10 ⁶ cu yds/yr | 15.9 AP / mi ² /yr |

Figure 7 shows each of the contributing watersheds and lists their estimated sediment production rates as well as the total average annual sediment load expected at the Mentone Dam site for current burn (CB) and reasonable maximum burn (RMB) conditions. The production rate listed adjacent to each watershed is the estimated amount for that watershed alone. These are not cumulative amounts. Total amounts are listed at the Mentone Dam site.

Estimated Standard Project Flood Sediment Production. Estimation of sediment production and delivery due to intense rain storms is a difficult task due to many complicating factors. Such factors include climatic variability, differences in local and area-wide geology, antecedent moisture content of the soil, river flow conditions and the character and availability of surface and channel sediment prior to the event.

As with the mean annual sediment estimate, peak discharge frequency data (Appendix A) developed by Rowe et al. (1949 and 1954), were used to estimate the sediment production and delivery as a result of the Standard Project Flood. Their procedures were not directly applicable, however, due to the extreme magnitude of the SPF event. Therefore, individual peak discharge frequency curves were developed for both burn conditions for each subbasin. These curves are shown in figures 8 through 13 for each subbasin for the two different burn conditions (CB and RMB). These curves were developed from the data tables listed in the Appendix .

Current burn conditions were derived to reflect the increased sediment production from burned portions of each watershed due to past fires. The same reasonable maximum burn forest conditions were used to develop the SPF curves as were used for the average annual curves.

Next, the SPF peak discharge was determined for each subbasin from the exceedance frequency that corresponds to the SPF peak discharge of 126,000 cfs expected at the Mentone damsite (US Army Corps of Engineers, 1980). These SPF peak discharges from each subbasin were used with the curves in Figure 14 to determine the cumulative erosion rate for each subbasin. (Figure 5 is repeated here as Figure 14 for reader convenience.) Therefore, peak discharges from Figures 8 through 13 were used with the curves in Figure 14 to determine the amount of sediment produced from each previously burned portion of the subbasin depending upon its recovery time. This procedure provided values for the volume of sediment produced from each subbasin as a result of an SPF storm event. Table 5 summarizes these results along with the estimated values for basinwide sediment yield under current burn and reasonable maximum burn conditions.

This method does not account for large-scale bank caving or landsliding. During an SPF event, it is possible to have more sediment entering water courses from bank caving and landslides than the Rowe method estimates. The material volume produced during an SPF event may be two or three times that estimated by this method (i.e., perhaps a total storm volume as large as 44×10^6 cubic yards). Unfortunately, there are no known ways to predict the occurrence of landslides, or the volume of material associated with them. Therefore, for the purposes of this study the computed erosion volume of 14.7×10^6 cubic yards of sediment will be used for the RMB SPF storm event.

Figure 15 shows each subbasin and lists its individual estimated SPF events production rates for CB and RMS conditions. Figure 15 also presents the cumulative total sediment volumes reaching the Mentone Dansite as a result of an SPF storm event.

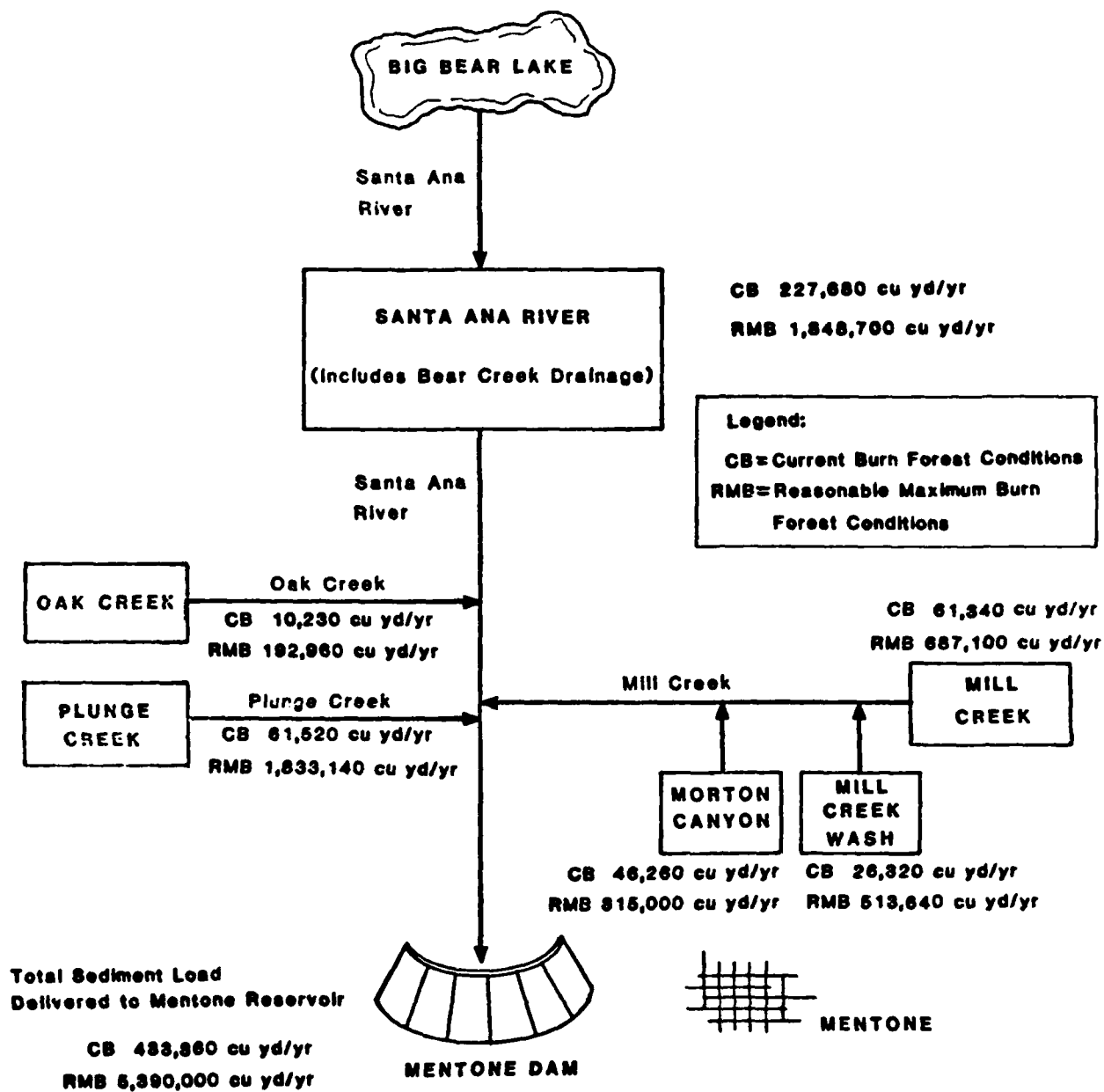

Figure 7

RUNOFF AND SEDIMENT CONTRIBUTING WATERSHEDS FOR THE SANTA ANA RIVER AT MENTONE, CALIFORNIA WITH THEIR ESTIMATED AVERAGE ANNUAL SEDIMENT PRODUCTION RATES

Table 5
Estimated Standard Project Flood Sediment Production

| Watershed (name) | Drainage Area (mi ²) | Current Burn Conditions | | Reasonable Maximum Burn Conditions | |
|---------------------|-------------------------------------|---|--|---|---|
| | | Watershed Burn History (Fire yr/% Burned) | Sediment Production (yd ³ /STORM)x10 ⁶ | Assumed RMB Conditions (Fire yr/% Burned) | Sediment Production (yd ³ /STORM)10 ⁶ |
| Santa Ana | 140.0 | 1970/45, 1979/05 | 1.233 | 1982/50 | 8.366 |
| Plunge Creek | 16.9 | 1970/90 | 0.220 | 1982/100 | 2.197 |
| Mill Creek | 43.2 | 1970/10 | 0.321 | 1982/50 | 2.732 |
| Morton Canyon | 2.5 | 1979/60 | 0.129 | 1982/100 | 0.330 |
| Mill Creek Wash | 4.3 | 1970/75, 1979/10 | 0.076 | 1982/100 | 0.546 |
| Oak Creek | 3.7 | 1970/35, 1979/10 | 0.048 | 1982/100 | 0.538 |
| Totals | 210.6 | | 2.026 x 10 ⁶ yd ³ /STORM 1256 AF/STORM | | 14.709 x 10 ⁶ yd ³ /STORM 9117 AF/STORM |

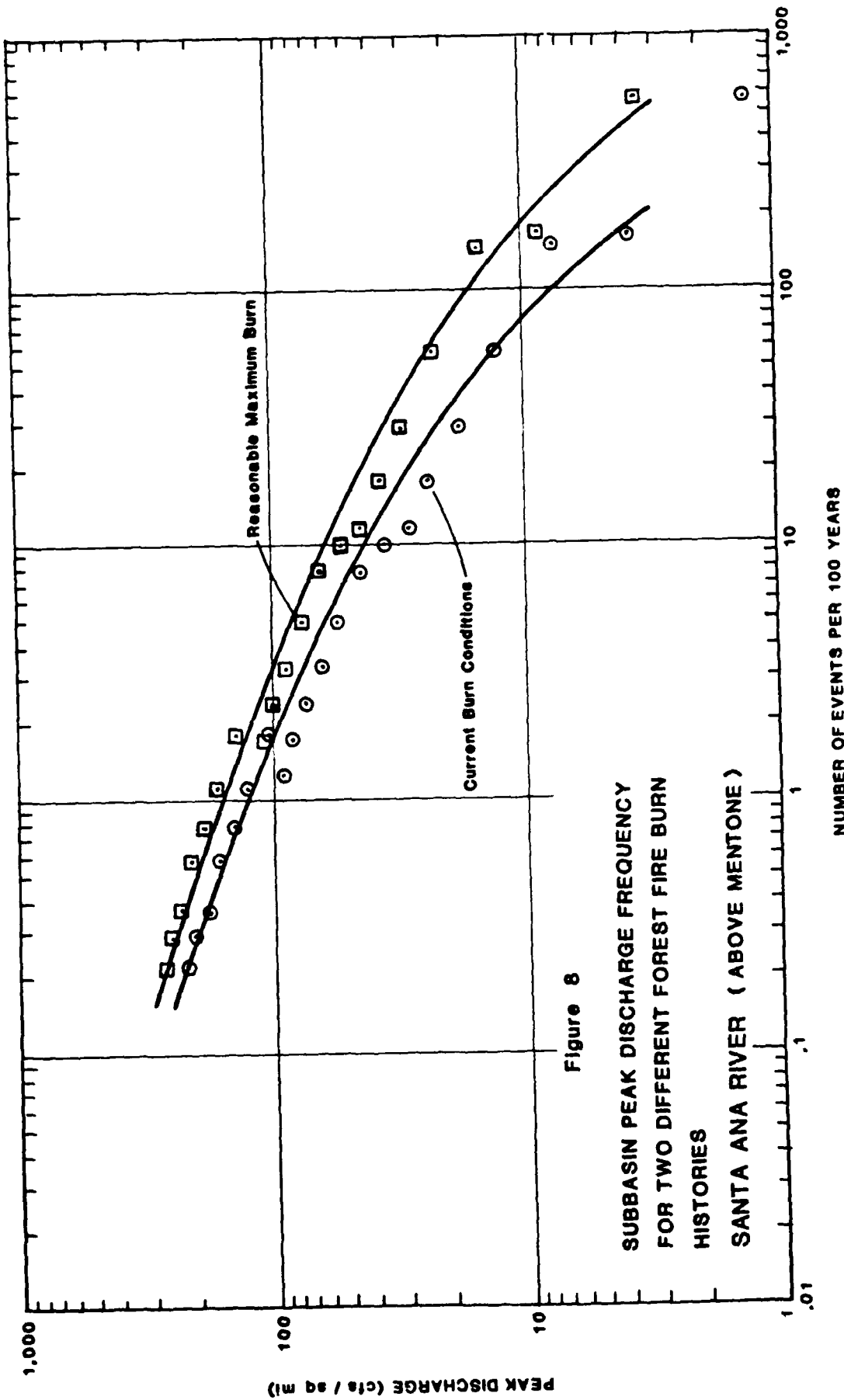

Figure 8

SUBBASIN PEAK DISCHARGE FREQUENCY
 FOR TWO DIFFERENT FOREST BURN
 HISTORIES
 SANTA ANA RIVER (ABOVE MENTONE)

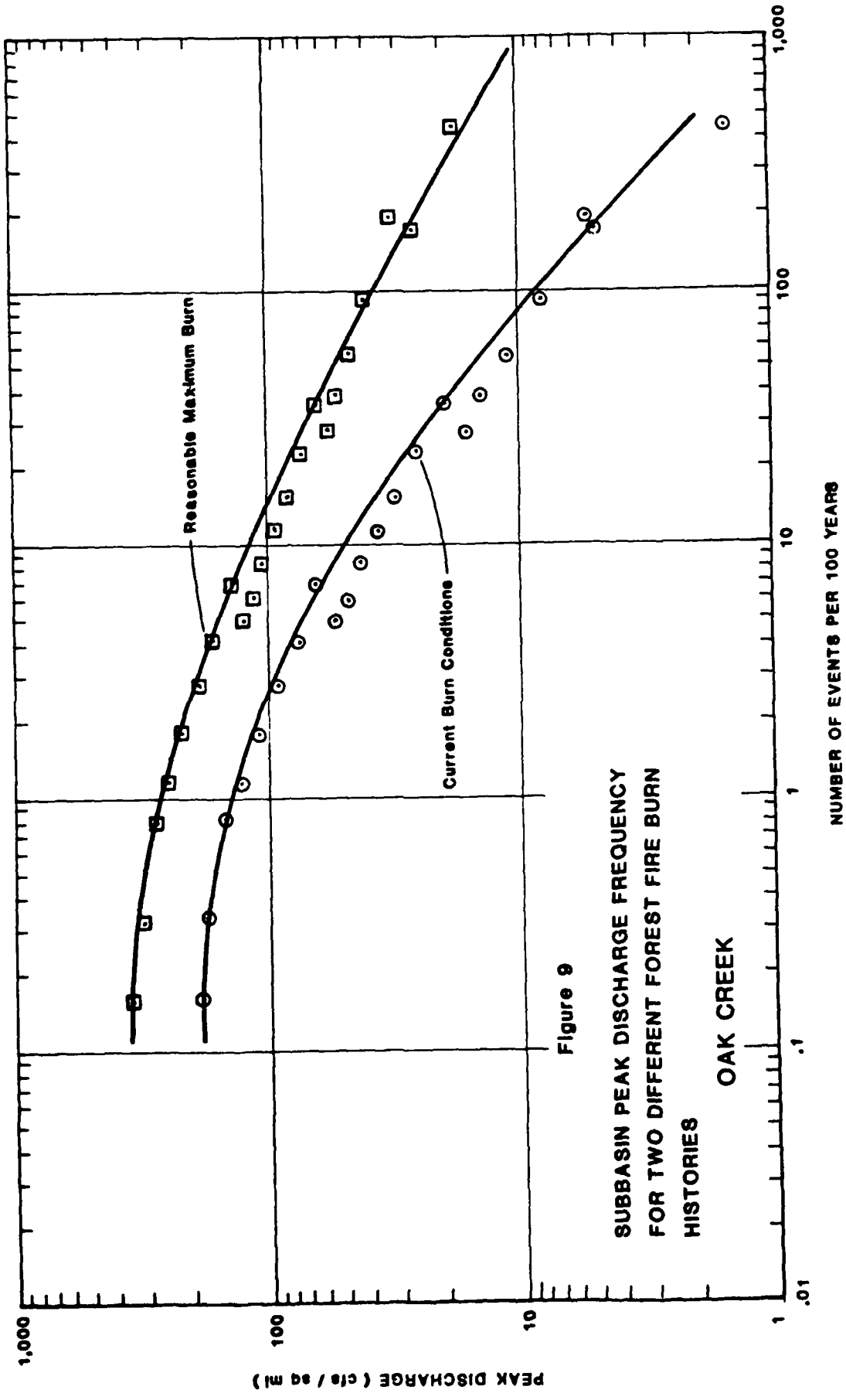

Figure 9

SUBBASIN PEAK DISCHARGE FREQUENCY
FOR TWO DIFFERENT FOREST FIRE BURN
HISTORIES
OAK CREEK

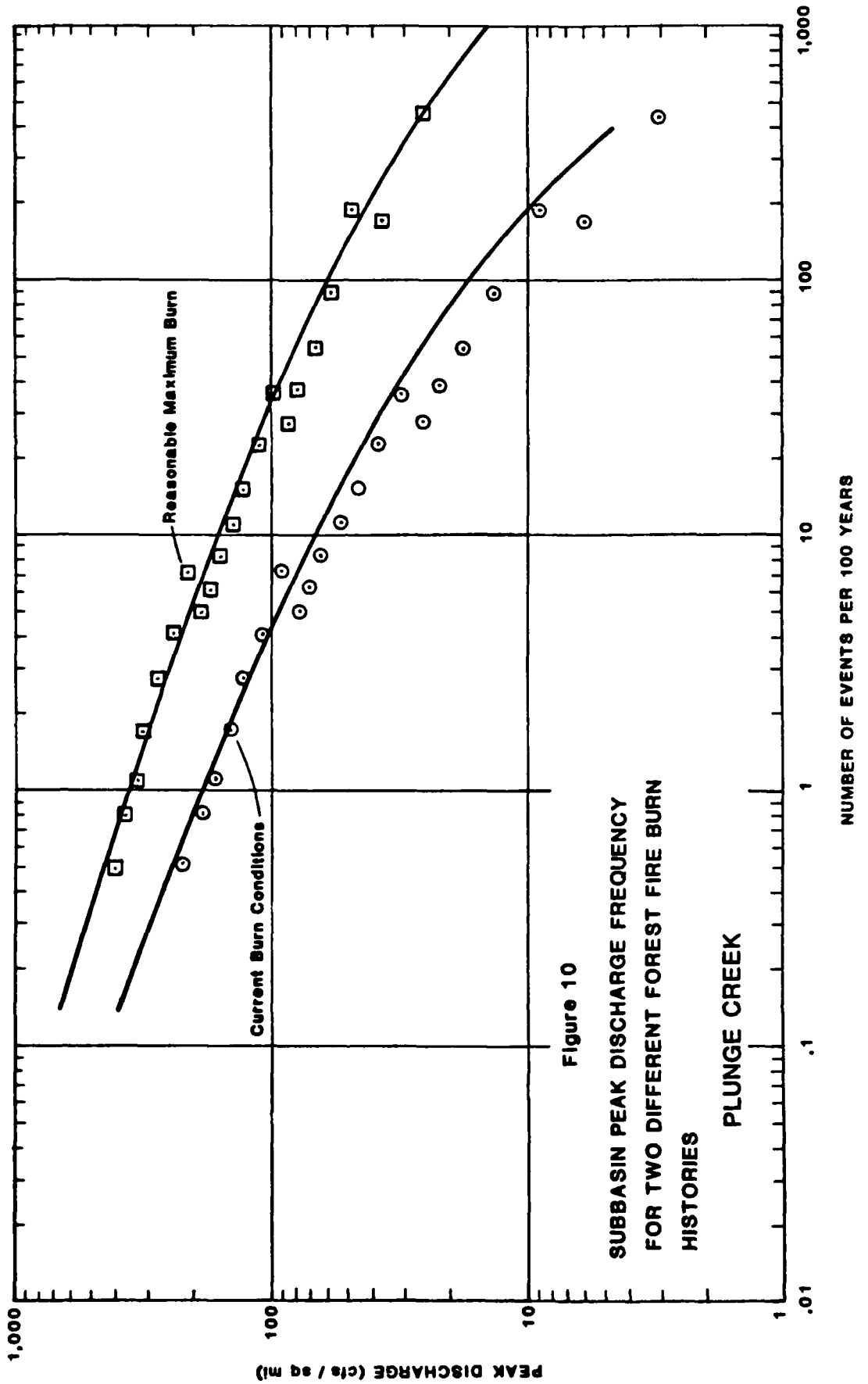

Figure 10
 SUBBASIN PEAK DISCHARGE FREQUENCY
 FOR TWO DIFFERENT FOREST FIRE BURN
 HISTORIES
 PLUNGE CREEK

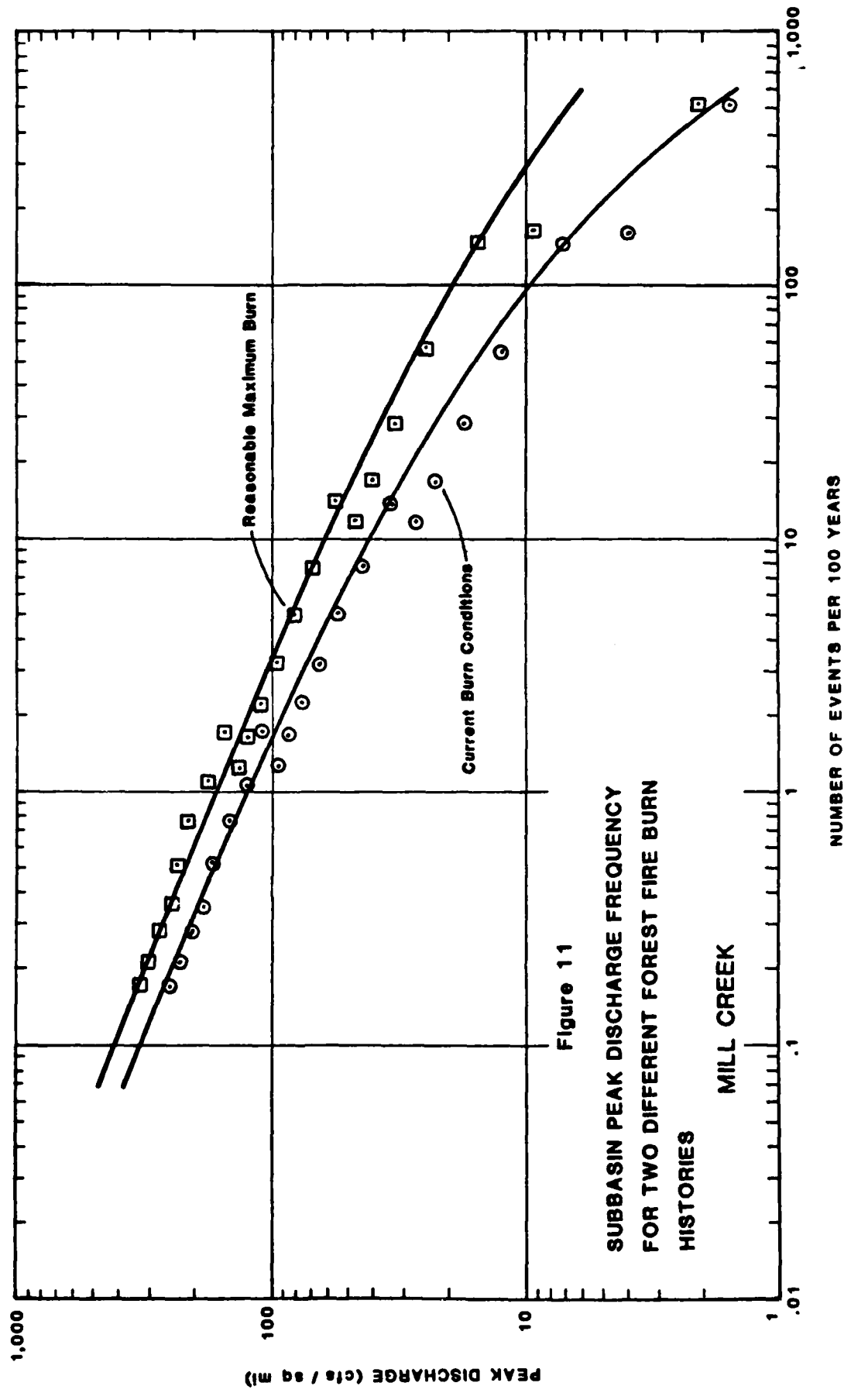

Figure 11
SUBBASIN PEAK DISCHARGE FREQUENCY
FOR TWO DIFFERENT FOREST FIRE BURN
HISTORIES
MILL CREEK

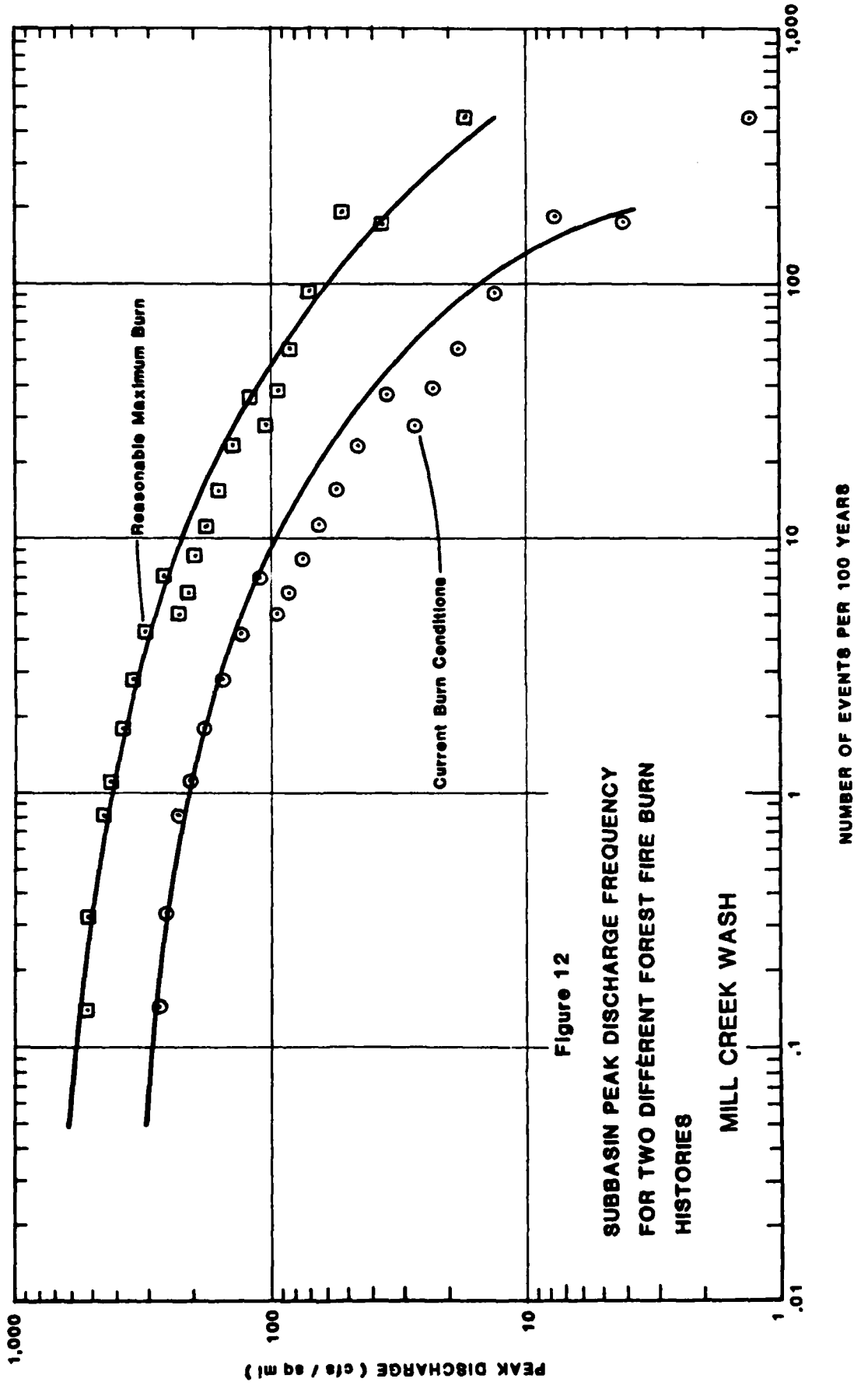

Figure 12
 SUBBASIN PEAK DISCHARGE FREQUENCY
 FOR TWO DIFFERENT FOREST FIRE BURN
 HISTORIES
 MILL CREEK WASH

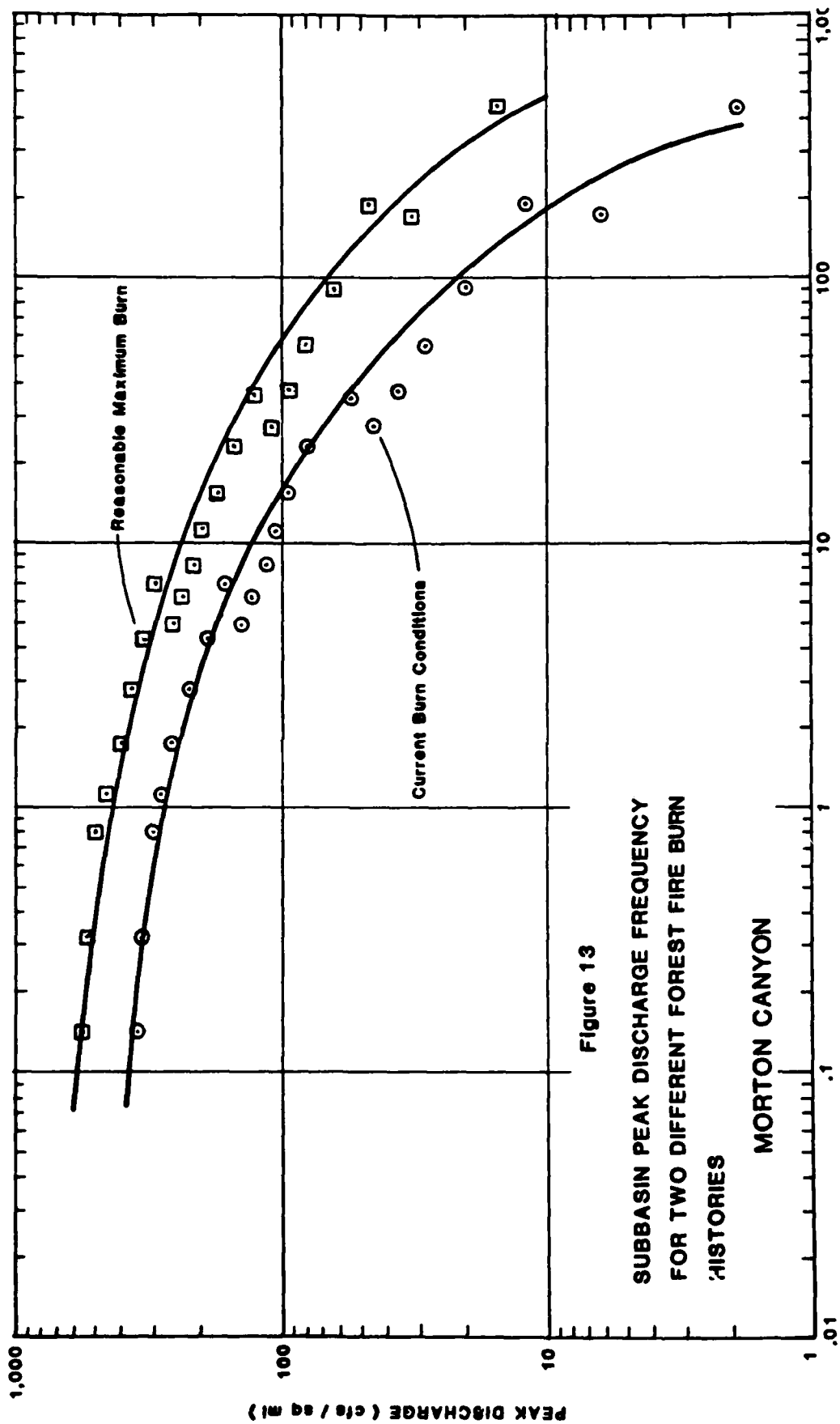
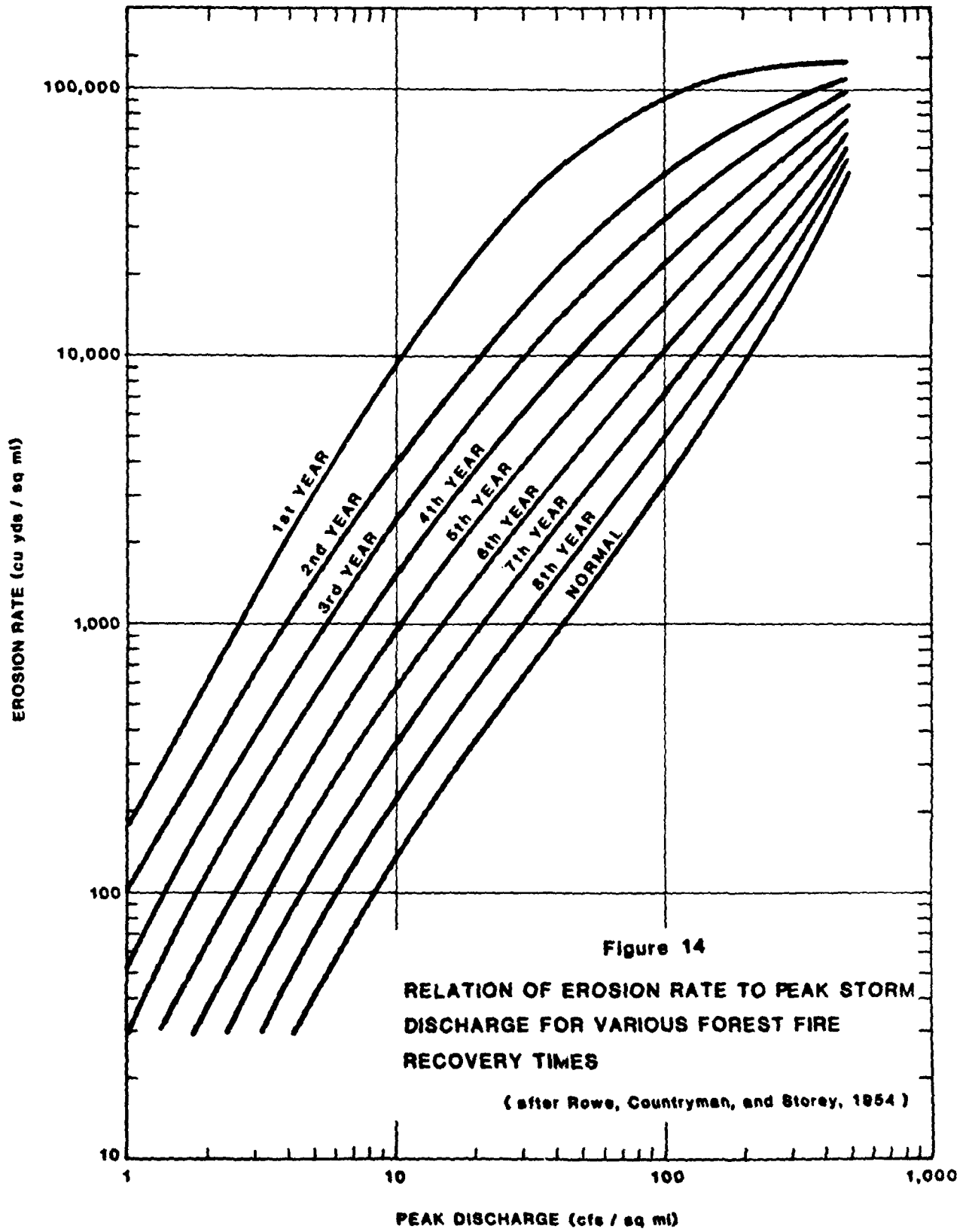

Figure 13

SUBBASIN PEAK DISCHARGE FREQUENCY
FOR TWO DIFFERENT FOREST FIRE BURN
HISTORIES

MORTON CANYON

NUMBER OF EVENTS PER 100 YEARS



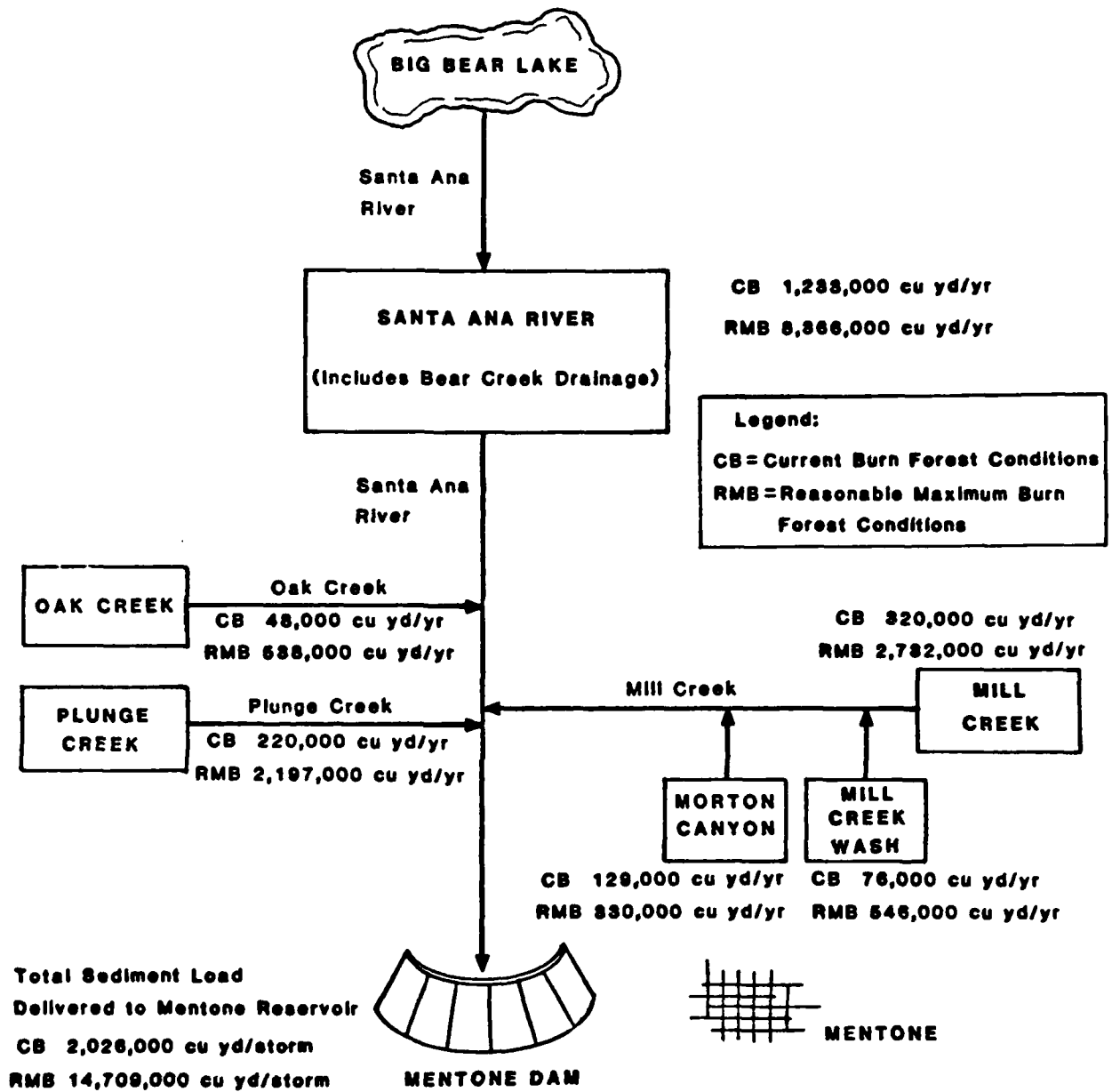

Figure 15

Runoff and Sediment Contributing Watersheds for the Santa Ana River at the Mentone Damsite with their Estimated Standard Project Flood Sediment Production Rates

EXTENT, THICKNESS AND COMPOSITION OF SEDIMENT DELTAS IN THE PROPOSED MENTONE RESERVOIR

Once the total sediment budgets had been developed for the two different burn conditions and hydrologic events, simplified empirical methods were used to estimate the size and depth of the resulting sediment deltas behind the proposed Mentone Dam. These rough estimates are summarized in Table 6 along with estimated grain size distributions for the deposited material. These results, based on simple mass volume procedures, provide only a rough estimate of the extent of the affected area and thickness of deposits. In order to provide a more accurate description of the delta shapes, thicknesses and spatial composition of deposited sediment materials, the computer program HEC-6 "Scour and Deposition in Rivers and Reservoirs" (HEC, 1977) was applied.

Application of Computer Program HEC-6

Computer program HEC-6 is a generalized sediment transport mathematical model. It has been widely used throughout the Corps, federal government, by universities and by private industry to simulate long-term streambed profile behavior. By mathematically coupling sediment transport processes and stream hydraulics, HEC-6 effectively simulates (1) scour and deposition, (2) accounts for streambed armoring and hydraulic sorting for up to fifteen different sediment grain sizes, (3) allows tributary inflow and/or diversions of both sediment and water, and (4) graphically displays the input and output if requested.

For the purposes of this investigation, HEC-6 was used to route the estimated amounts of sediment and runoff (as summarized in the preceding section) into the proposed Mentone Reservoir. Once these sediments reached the reservoir, sophisticated algorithms within the code simulated selective transport and deposition of the various sediment grain sizes in the reservoir pool. Thus a reservoir delta forms as layers of sediment deposit during an event. HEC-6 simulates the longitudinal profile shape, depth of deposit and grain size distribution within the delta deposits. It also computes the reservoir trap efficiency and total volume of sediment deposited in the reservoir. The model accounts for successive filling and emptying of the reservoir during each hydrologic event. Exposed delta deposits from previous events are transported toward the dam as they are scoured by high flow during repeated filling and emptying of the reservoir with each event.

Delta Simulations

A method for estimating the effects of periodic fires on peak discharge and erosion rates from watersheds located in the Upper Santa Ana River drainage basin has been successfully used to develop the sediment budget for the proposed Mentone Dam site. Sediment volumes and delivery data developed by this method (adapted from Rowe et al. 1954) were used to develop inflowing sediment load relationships for computer program HEC-6. Bed material characteristics were obtained from data collected during reconnaissance studies and boring data gathered by the Los Angeles District (US Army Corps of Engineers, 1980). Grain size distribution for the inflowing sediment load was computed from

Table 6
 Estimated Thicknesses of Sediment Deposits
 at the Mentone Dam Site Using Empirical Approximations

| | <u>Two-Year Flood Event</u> | | <u>Fifty Years of Flow,</u> | | <u>Standard Project Flood,</u> |
|--------------------------------------|-----------------------------|-------------------|--------------------------------|--------------------------------|--------------------------------|
| | <u>Current</u> | <u>Reasonable</u> | <u>Current Burn Conditions</u> | <u>Current Burn Conditions</u> | |
| Estimated Area of deposition (acres) | 250 | 250 | 460 | 745 | 745 |
| Deposit Thickness (feet) | 1.08 | 13.4 | 29.2 | 1.7 | 12.2 |

Standard Project Flood,
 Reasonable Maximum Burn
 Conditions

Estimated Grain Size Distributions for Deposited Materials

| | D85 | D60 | D50 | D30 | D10 |
|----------------------|------|------|-------|--------|--------|
| Grain Size in mm. | 48.5 | 8.9 | 2.5 | 0.66 | 0.32 |
| Grain Size in inches | 1.9 | 0.35 | 0.098 | 0.0026 | 0.0126 |

Soil Conservation Service (U. S. Department of Agriculture, 1980) soil survey information for the drainages above the project area. It was estimated that 30, 55, and 15 percent of the total estimated sediment volumes would be composed of fines (clays and silts), sands, and gravels and cobbles, respectively. Single event hydrographs were developed from data reported in the Hydrology section of the Phase I GDM (US Army Corps of Engineers, 1980). Table 7 summarizes the types of hydrologic events and forest watershed conditions considered by this study.

Comparison of computed sediment yields with measured yield data from several adjacent and similar watersheds (see Table 3) supports the accuracy of the estimated sediment production rate and computed sediment volumes reported in Tables 2, 4, and 5. End-of-event reservoir bottom profiles are presented in Figures 16 through 20. These profile plots show the longitudinal and vertical extent of the delta deposits simulated by computer program HEC-6. Figures 21 through 23 show the estimated spatial extent of deltas resulting from the SPF, 50 years of mean annual flows and 100 years of mean annual flows, respectively.

The actual spatial distribution and delta shape will be different from what is shown in Figures 21 through 26. However, the overall extent and depths of deposits should represent expected delta conditions within the reservoir. For simplicity, it was assumed that all of the sediment loads from Plunge Creek, Santa Ana River and Mill Creek entered as one flow oriented in the center of the reservoir. Otherwise, the complex interaction of three intersecting deltas would have to be simulated. The lateral extent of the simulated delta deposits was prescribed by the movable bed width for each cross section used in the HEC-6 model. These widths were based on the shape and contour of the reservoir bottom and on the anticipated water surface elevation for each flood event. Detailed analyses of multidimensional flows such as these are beyond the capabilities of computer program HEC-6. It was also felt that HEC-6 would produce the most conservative results as far as simulating the largest extend and overall size of the delta.

Tables 8 through 12 present the simulated sediment grain size distributions at each cross section in the reservoir area. Table 13 summarizes the simulated sediment depths computed at each cross section for the five different hydrologic events and watershed burn conditions considered.

Maximum depths of delta deposits varied from about 2 to 15 feet for mean annual flows corresponding to current burn and reasonable maximum burn conditions, respectively. A maximum accumulated depth of 34 feet was extrapolated after fifty years of mean annual flows subject to current burn conditions. The 100-year delta deposit was extrapolated to be 40 to 50 feet deep at its deepest point.

The simulated delta profiles possess reservoir delta characteristics as described by Vanoni (1975). Figure 27 presents a sketch of the typical shape of a reservoir delta. Comparison of the characteristics of this sketch with the simulated results presented in Figures 16 through 20 shows that the simulated profiles are very realistic. The longitudinal distributions of various sizes of sediment materials (Tables 8 through

Table 7
Summary of Graphical and Tabular Results⁽¹⁾

| | <u>Type of Hydrologic Event</u> | | |
|----------------------------|--|---|-----------------------------|
| | Typical Two-Year Flood Event (Mean Annual Flood) | : Fifty Years :(Fifty Successive: Mean Ann. Flds.): | : Standard Project Flood |
| Forest Burn Conditions | | | |
| Current Burn | Figure 16 Table 8 | Figure 20 ⁽²⁾ Table 12 | Figure 18 Table 10 |
| Reasonable Maximum Burn | Figure 17 Table 9 | Not Considered | Figure 19 Table 11 |

(1) Refer to the indicated Figure and Table numbers for the computer-simulated results of the delta profiles and sediment grain size distributions for the different hydrologic events evaluated.

(2) The 100-year delta was extrapolated from the fifty-year data for current burn conditions (see Figure 26).

12) also compare well with what is normally observed in typical reservoirs. Coarser sized materials accumulate near the mouth of the river and become progressively finer farther into the reservoir.

Based on these results and comparisons with similar reservoirs, the simulated delta profiles, thicknesses, spatial extent, and grain size distributions are reasonable.

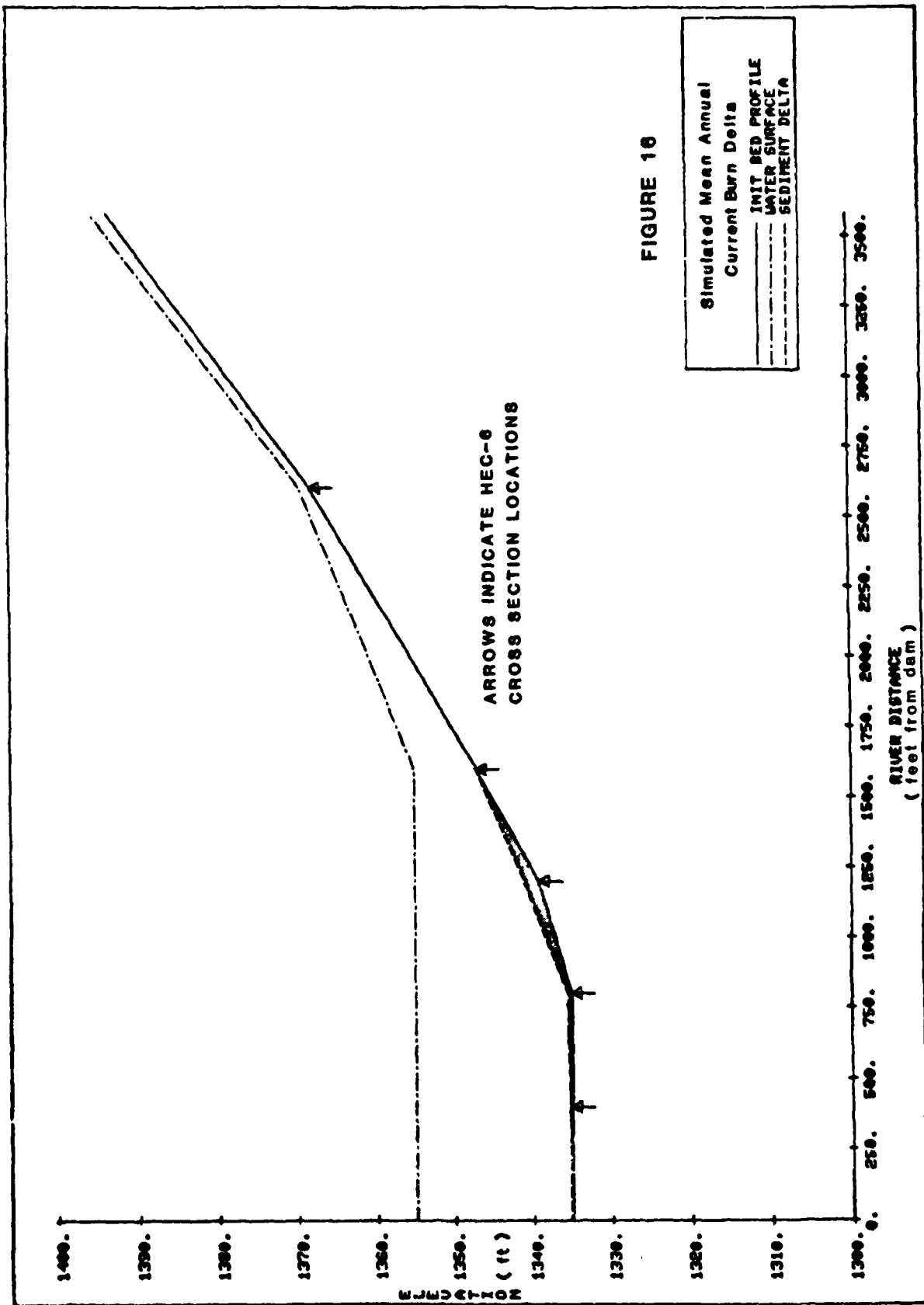

FIGURE 10

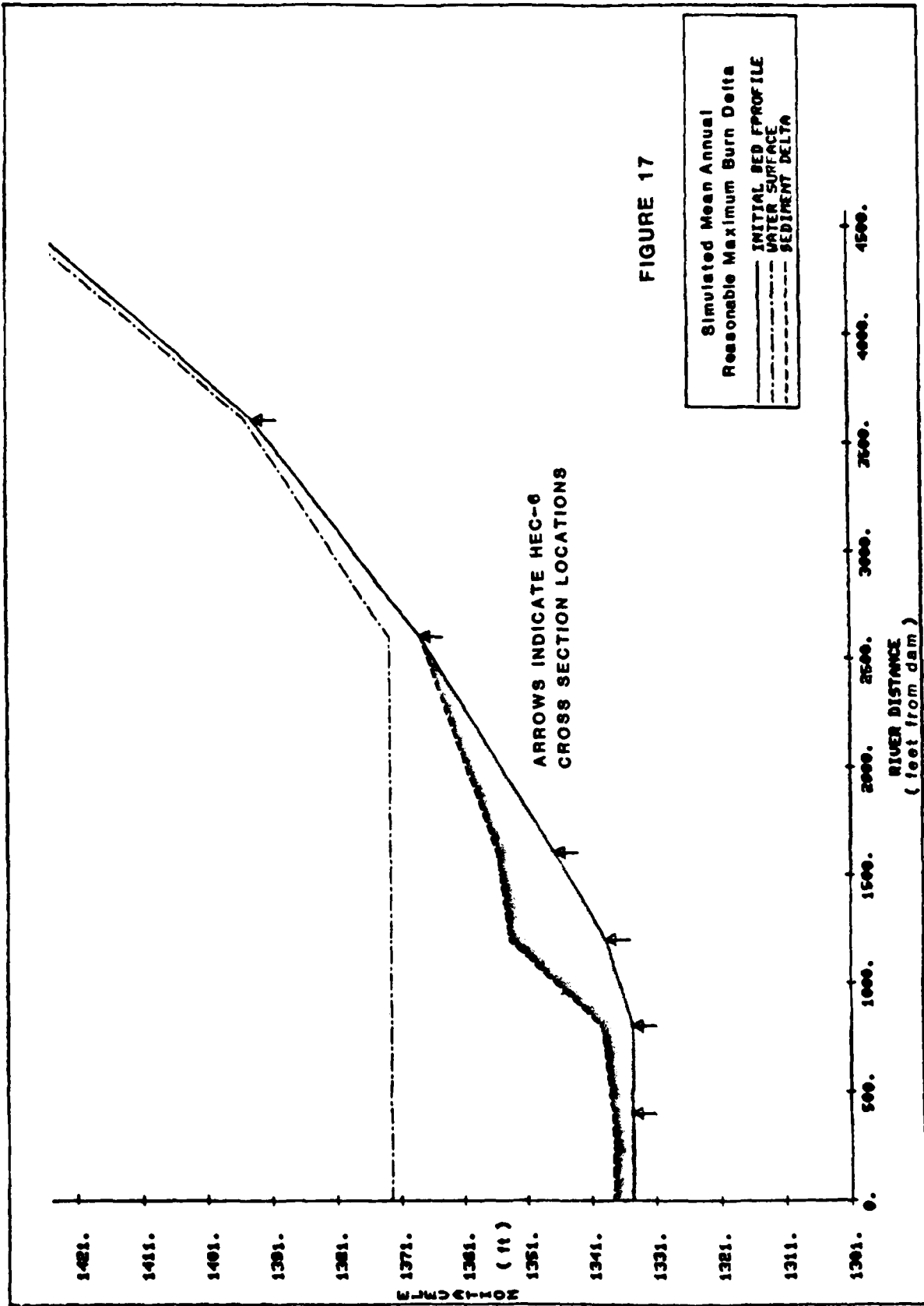

FIGURE 17

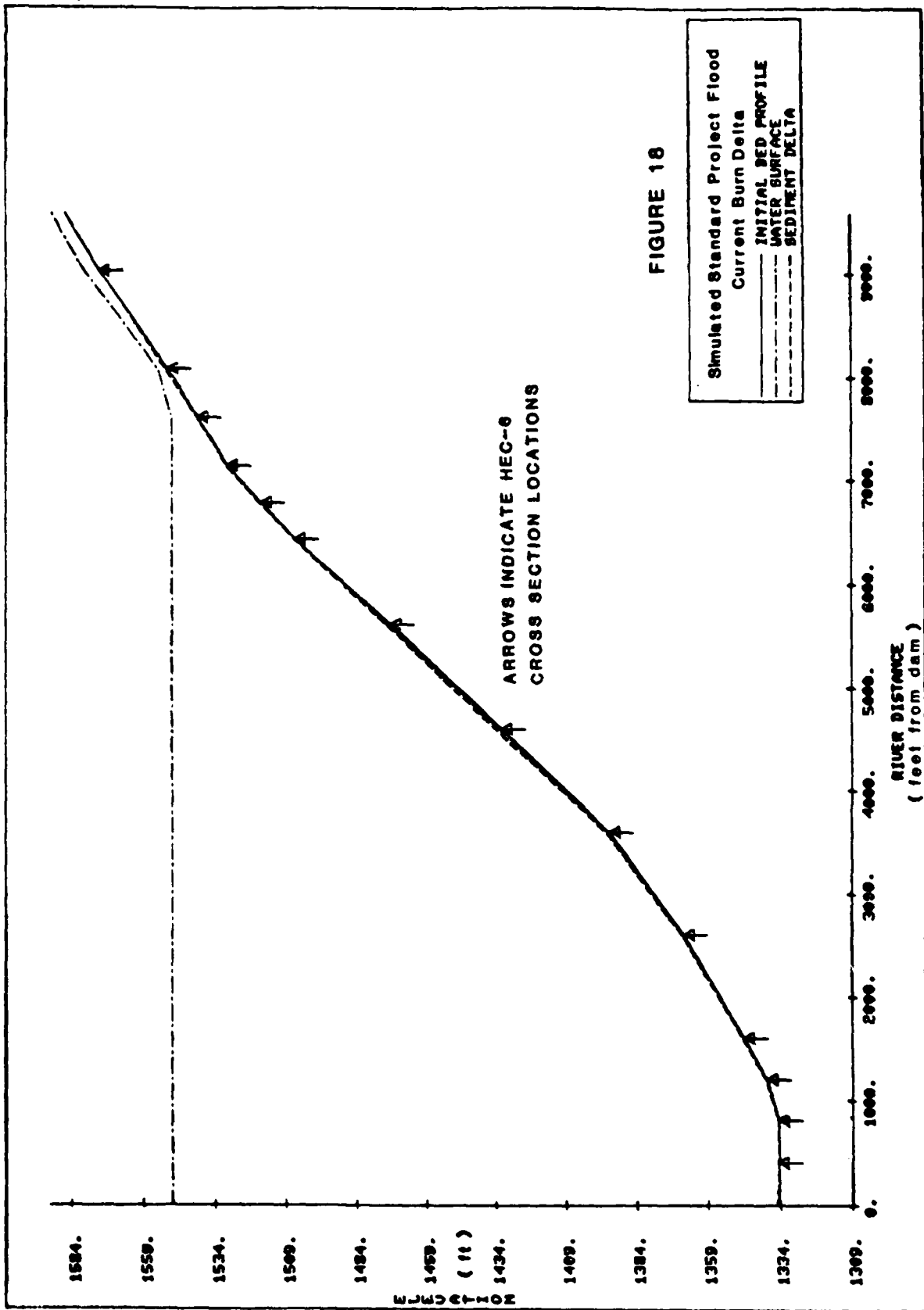

FIGURE 18

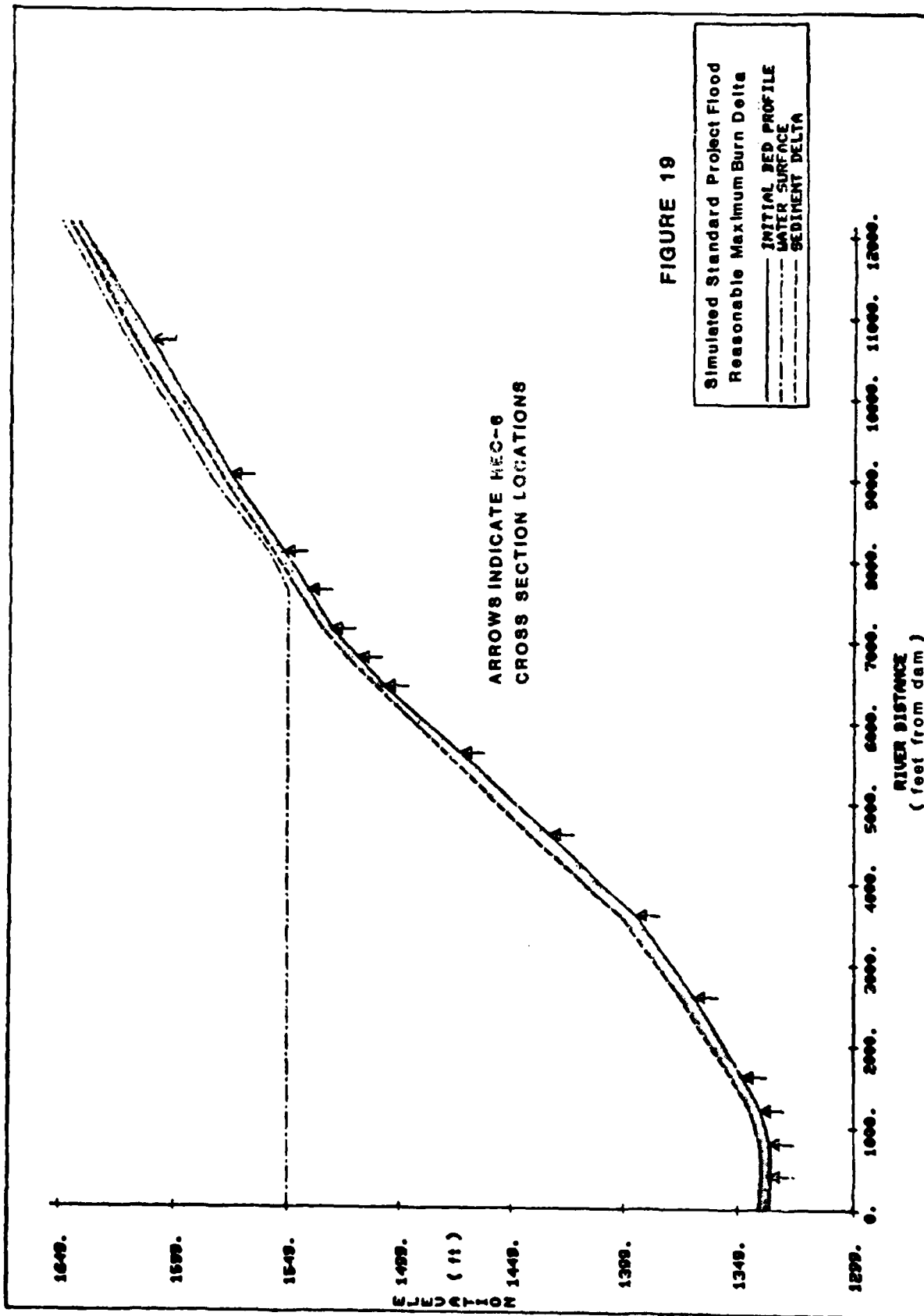

FIGURE 19

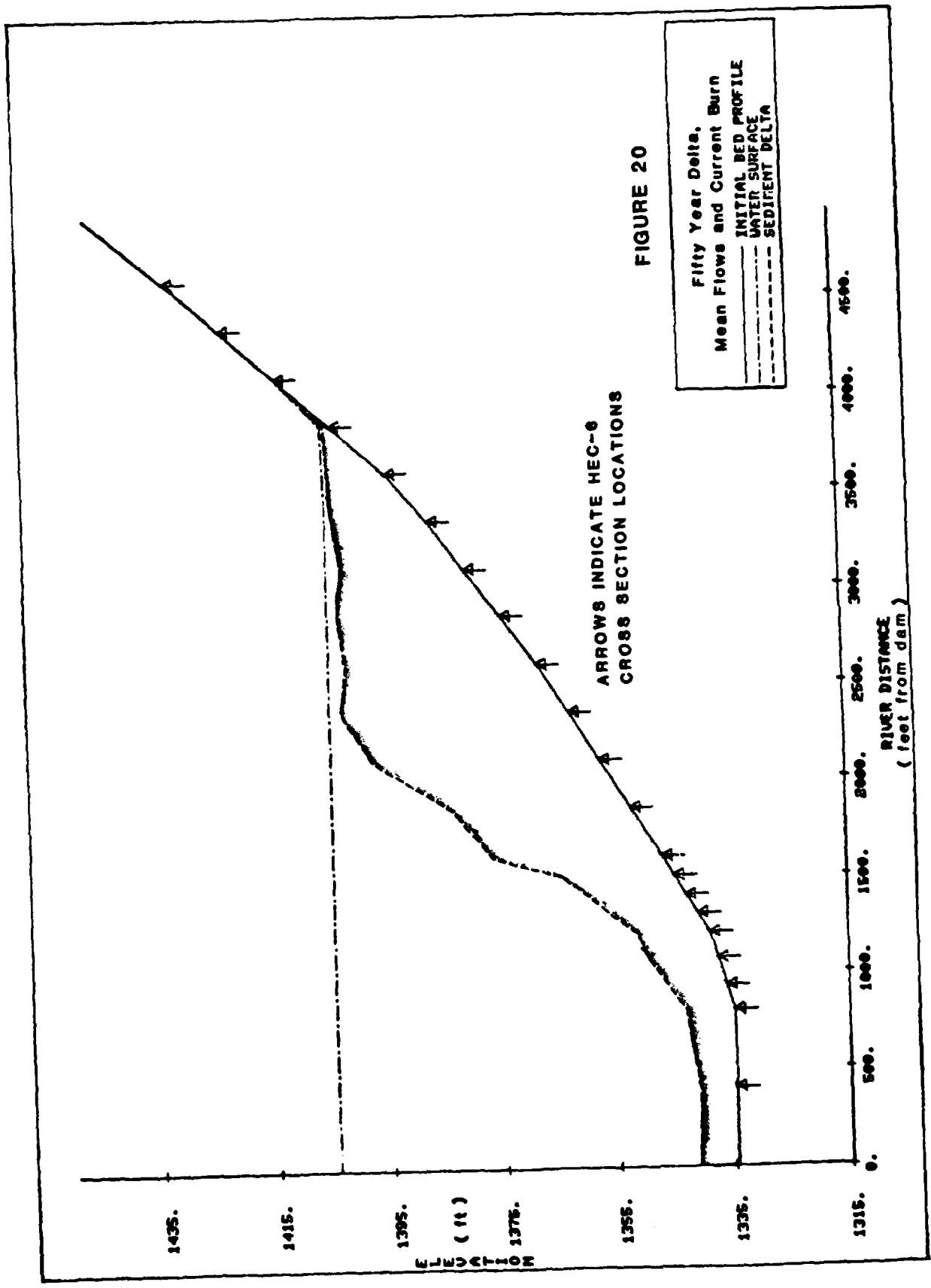
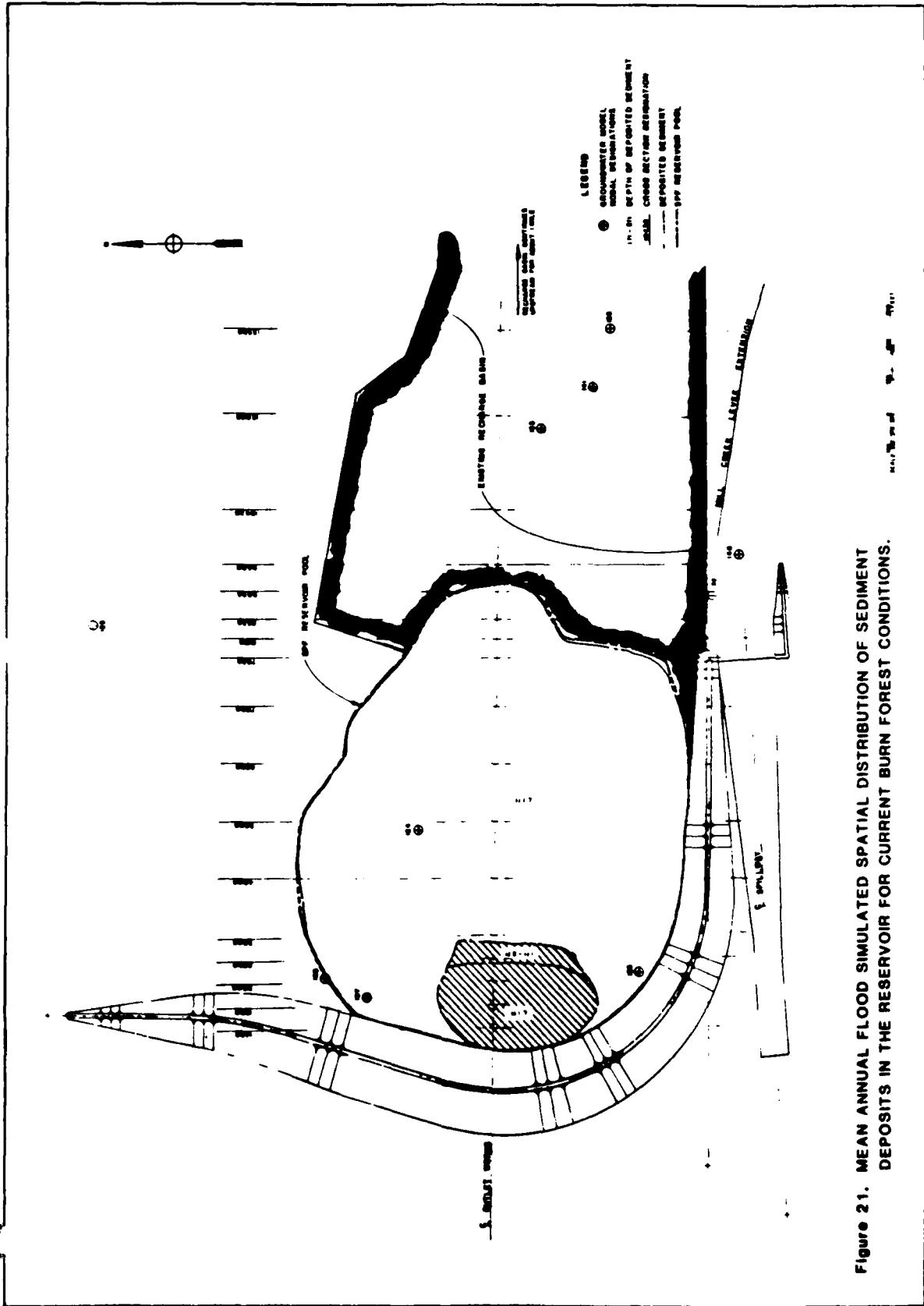

FIGURE 20



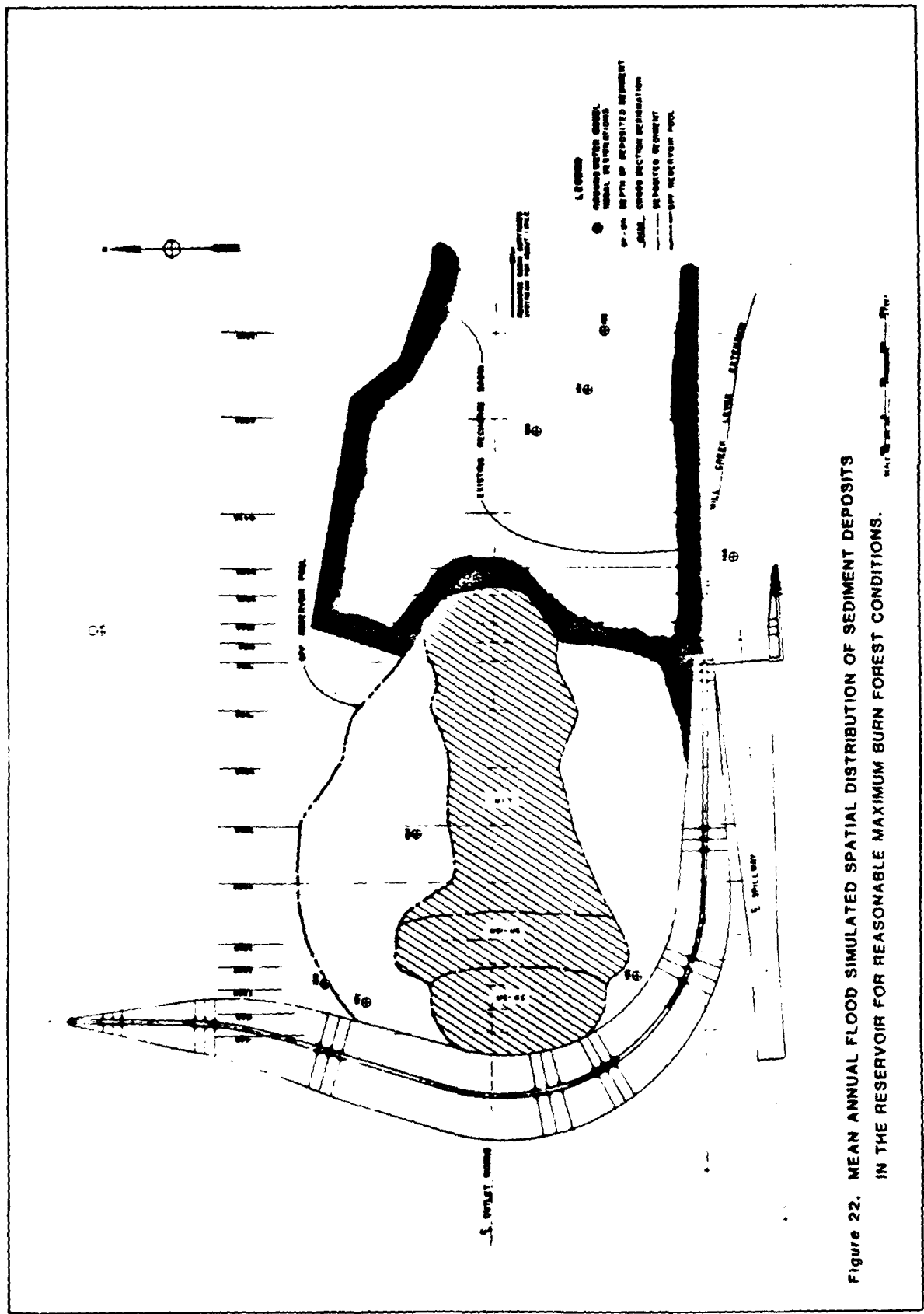

Figure 22. MEAN ANNUAL FLOOD SIMULATED SPATIAL DISTRIBUTION OF SEDIMENT DEPOSITS IN THE RESERVOIR FOR REASONABLE MAXIMUM BURN FOREST CONDITIONS.

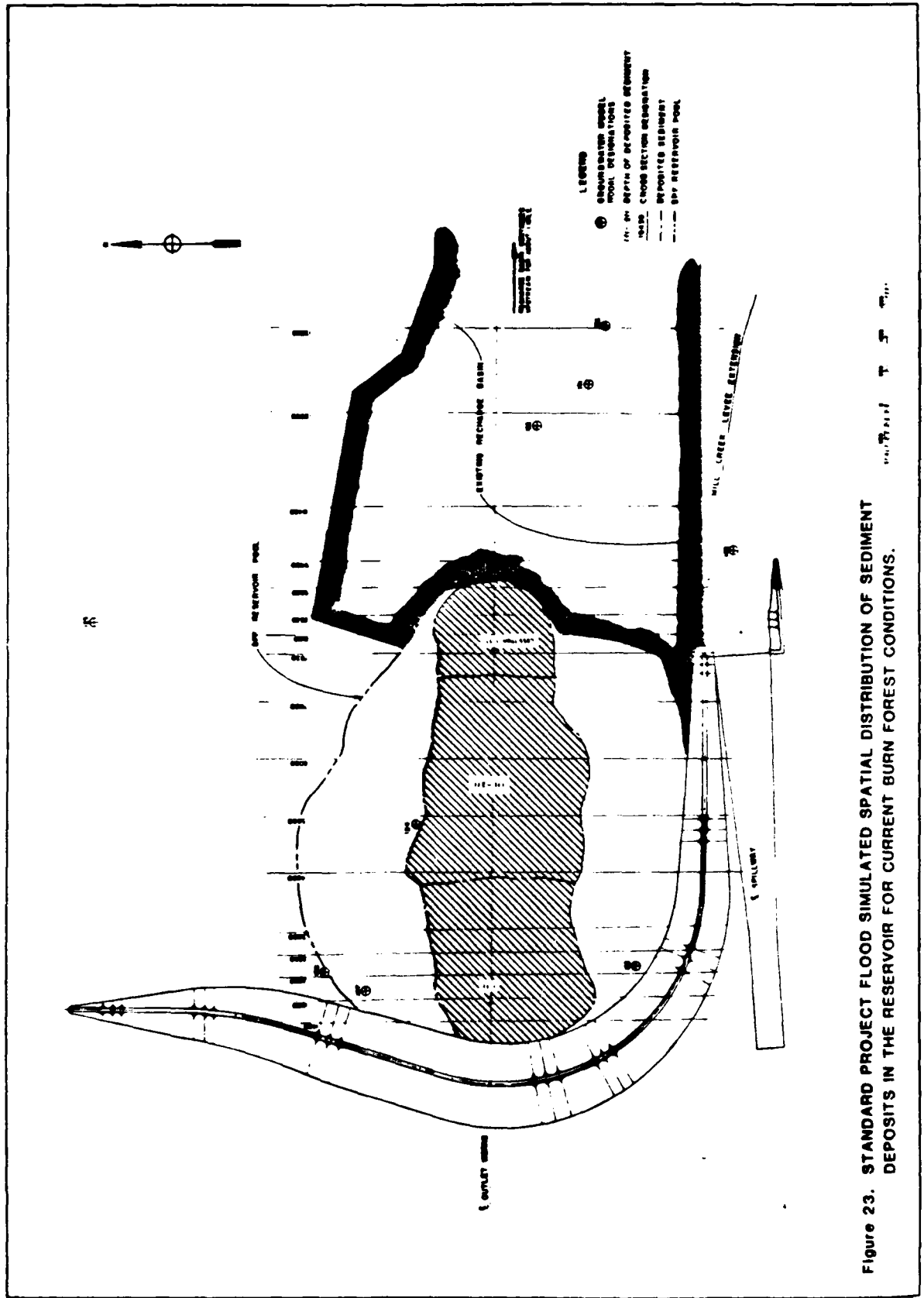

Figure 23. STANDARD PROJECT FLOOD SIMULATED SPATIAL DISTRIBUTION OF SEDIMENT DEPOSITS IN THE RESERVOIR FOR CURRENT BURN FOREST CONDITIONS.

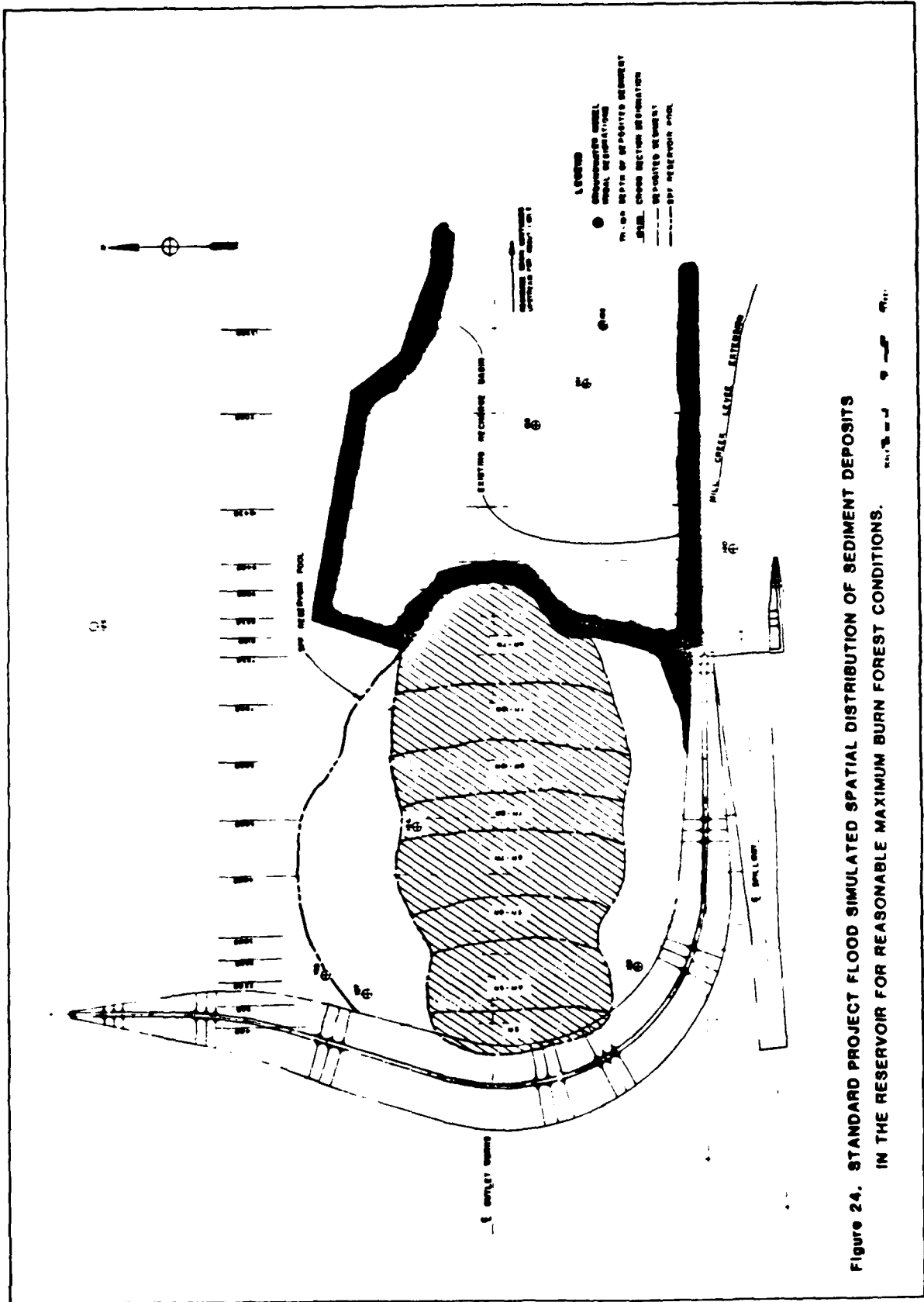

Figure 24. STANDARD PROJECT FLOOD SIMULATED SPATIAL DISTRIBUTION OF SEDIMENT DEPOSITS IN THE RESERVOIR FOR REASONABLE MAXIMUM BURN FOREST CONDITIONS.

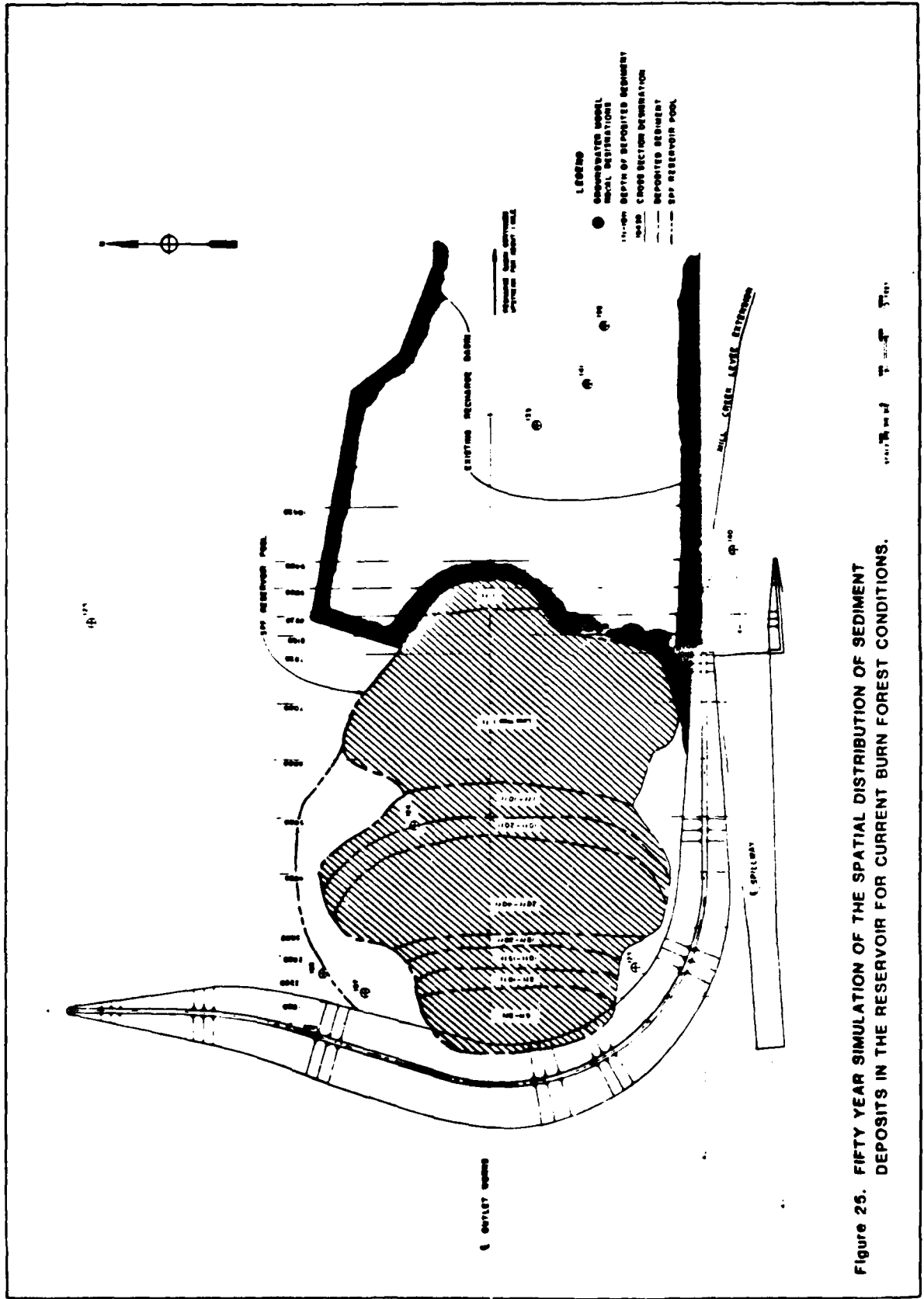

Figure 25. FIFTY YEAR SIMULATION OF THE SPATIAL DISTRIBUTION OF SEDIMENT DEPOSITS IN THE RESERVOIR FOR CURRENT BURN FOREST CONDITIONS.

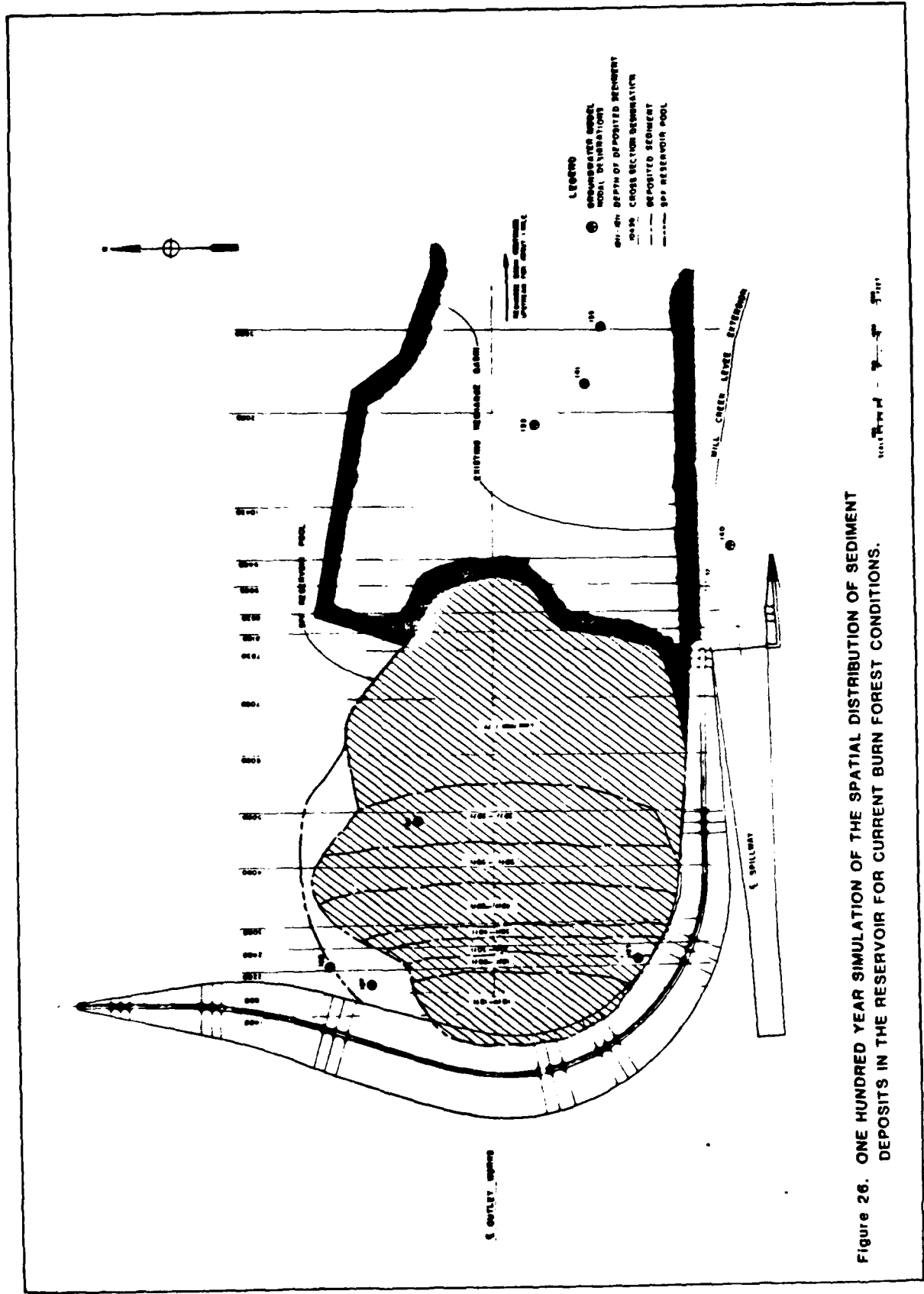

Figure 26. ONE HUNDRED YEAR SIMULATION OF THE SPATIAL DISTRIBUTION OF SEDIMENT DEPOSITS IN THE RESERVOIR FOR CURRENT BURN FOREST CONDITIONS.

Table 8

Grain Size Distribution at the Mentone Damsite
As a Result of the Mean Annual Flood and Current Burn Conditions

| Material | Grain Size Diameter (mm) | Distance from dam (feet) | | | | | | | | | | | | | | | | | | | |
|--------------------|--------------------------|--------------------------|------|------|------|------|------|------|------|------|------|------|------|------|------|-------|-------|-------|-------|-------|------|
| | | 1400 | 1800 | 2200 | 2600 | 3000 | 4000 | 5000 | 6000 | 7000 | 7830 | 8180 | 8530 | 9005 | 9480 | 10430 | 12080 | 13580 | 15080 | 16580 | |
| Clay | <.016 | .312 | .293 | .267 | .113 | .002 | .001 | .002 | .002 | .002 | .002 | .002 | .002 | .002 | .002 | .002 | .001 | .001 | .001 | .002 | .005 |
| Silt | .016-.031 (.022) | .034 | .087 | .303 | .720 | .004 | .004 | .005 | .005 | .006 | .005 | .005 | .005 | .004 | .004 | .003 | .004 | .004 | .005 | .005 | .012 |
| Fine Sand | .125-.250 (.177) | .009 | .009 | .006 | .020 | .113 | .156 | .014 | .095 | .014 | .086 | .016 | .083 | .026 | .082 | .074 | .176 | .093 | .059 | .038 | |
| Medium Sand | .250-.500 (.354) | .059 | .056 | .039 | .017 | .118 | .107 | .090 | .077 | .090 | .080 | .090 | .101 | .096 | .114 | .116 | .163 | .151 | .114 | .070 | |
| Coarse Sand | .500-1.0 (.707) | .138 | .131 | .091 | .032 | .210 | .197 | .210 | .175 | .210 | .153 | .210 | .189 | .209 | .206 | .209 | .188 | .186 | .160 | .101 | |
| Very Coarse Sand | 1.0-2.0 (1.416) | .177 | .168 | .117 | .039 | .240 | .229 | .270 | .246 | .270 | .211 | .269 | .235 | .266 | .251 | .255 | .209 | .235 | .221 | .140 | |
| Very Fine Gravel | 2.0-4.0 (2.83) | .085 | .081 | .056 | .019 | .103 | .103 | .130 | .125 | .130 | .114 | .130 | .116 | .128 | .121 | .124 | .094 | .116 | .134 | .101 | |
| Fine Gravel | 4.0-8.0 (5.66) | .046 | .044 | .030 | .010 | .053 | .051 | .070 | .069 | .070 | .087 | .070 | .067 | .067 | .056 | .065 | .051 | .059 | .071 | .053 | |
| Medium Gravel | 8.0-16.0 (11.31) | .036 | .034 | .024 | .008 | .042 | .040 | .055 | .054 | .055 | .069 | .055 | .053 | .053 | .044 | .040 | .033 | .042 | .064 | .109 | |
| Coarse Gravel | 16.0-32.0 (22.63) | .036 | .034 | .024 | .008 | .042 | .040 | .055 | .054 | .055 | .069 | .055 | .053 | .053 | .044 | .040 | .030 | .040 | .060 | .135 | |
| Very Coarse Gravel | 32.0-64.0 (45.26) | .063 | .059 | .041 | .014 | .072 | .069 | .095 | .094 | .095 | .119 | .095 | .091 | .091 | .075 | .069 | .051 | .069 | .104 | .227 | |

Table 9

Grain Size Distribution at the Mentone Dam Site
As a Result of the Mean Annual Flood and Reasonable Maximum Run Conditions

| Material | Grain Size Diameter (mm) | Distance from Dam (feet) | | | | | | | | | | | Percentage in the Bed | | | | | | | | | | |
|--------------------|--------------------------|--------------------------|------|------|------|------|------|------|------|------|------|------|-----------------------|------|------|-------|-------|-------|-------|-------|--|--|--|
| | | 1400 | 1800 | 2200 | 2600 | 3000 | 4000 | 5000 | 6000 | 7000 | 7830 | 8180 | 8530 | 9005 | 9480 | 10430 | 12080 | 13580 | 15080 | 16580 | | | |
| Clay | <.016 | .808 | .780 | .673 | .229 | .124 | .001 | .001 | .002 | .002 | .002 | .002 | .001 | .001 | .001 | .001 | .001 | .001 | .001 | .000 | | | |
| Silt | .016-.031 (.022) | .018 | .054 | .225 | .746 | .834 | .003 | .004 | .005 | .006 | .006 | .005 | .004 | .003 | .003 | .002 | .002 | .002 | .003 | .001 | | | |
| Fine Sand | .125-.250 (.177) | .002 | .002 | .001 | .001 | .006 | .271 | .235 | .096 | .162 | .071 | .112 | .064 | .222 | .273 | .325 | .465 | .360 | .260 | .317 | | | |
| Medium Sand | .250-.500 (.354) | .016 | .015 | .009 | .002 | .004 | .097 | .081 | .078 | .060 | .077 | .076 | .088 | .092 | .099 | .108 | .143 | .200 | .228 | .240 | | | |
| Coarse Sand | .500-1.0 (.707) | .037 | .035 | .022 | .005 | .008 | .172 | .172 | .188 | .152 | .176 | .159 | .193 | .168 | .160 | .166 | .111 | .129 | .165 | .183 | | | |
| Very Coarse Sand | 1.0-2.0 (1.414) | .047 | .045 | .028 | .006 | .010 | .196 | .211 | .241 | .228 | .235 | .212 | .247 | .210 | .195 | .174 | .120 | .130 | .141 | .142 | | | |
| Very Fine Gravel | 2.0-4.0 (2.83) | .023 | .022 | .013 | .003 | .005 | .087 | .099 | .123 | .120 | .118 | .114 | .120 | .100 | .095 | .083 | .054 | .060 | .066 | .065 | | | |
| Fine Gravel | 4.0-8.0 (5.66) | .012 | .012 | .007 | .002 | .002 | .043 | .050 | .065 | .068 | .076 | .080 | .070 | .051 | .045 | .047 | .029 | .031 | .030 | .019 | | | |
| Medium Gravel | 8.0-16.0 (11.31) | .010 | .009 | .006 | .001 | .002 | .034 | .039 | .050 | .054 | .063 | .063 | .055 | .040 | .034 | .030 | .021 | .023 | .027 | .012 | | | |
| Coarse Gravel | 16.0-32.0 (22.63) | .010 | .009 | .006 | .001 | .002 | .034 | .039 | .050 | .054 | .063 | .063 | .055 | .040 | .034 | .030 | .020 | .023 | .028 | .007 | | | |
| Very Coarse Gravel | 32.0-64.0 (65.26) | .017 | .016 | .010 | .002 | .003 | .059 | .067 | .087 | .091 | .109 | .109 | .095 | .069 | .059 | .051 | .034 | .040 | .049 | .013 | | | |

Table 10
Grain Size Distribution at the Mentone Damsite
As a Result of the Standard Project Flood and Current Run Conditions

| Material | Grain Size Diameter (mm) | Distance from Dam (feet) | | | | | | | | | | | | | | | | | | |
|--------------------|--------------------------|--------------------------|------|------|------|------|------|------|------|------|------|------|------|------|------|-------|-------|-------|-------|-------|
| | | 1400 | 1800 | 2200 | 2600 | 3000 | 4000 | 5000 | 6000 | 7000 | 7830 | 8180 | 8530 | 9005 | 9480 | 10430 | 12080 | 13580 | 15080 | 16580 |
| Clay | <.016 | .057 | .051 | .050 | .043 | .030 | .016 | .013 | .003 | .002 | .006 | .004 | .003 | .001 | .000 | .009 | .026 | .181 | .172 | .035 |
| Silt | .016-.031 (.022) | .499 | .464 | .494 | .458 | .351 | .210 | .174 | .046 | .025 | .071 | .040 | .044 | .002 | .001 | .023 | .066 | .453 | .429 | .088 |
| Fine Sand | .125-.250 (.177) | .006 | .007 | .011 | .028 | .068 | .083 | .199 | .274 | .144 | .182 | .169 | .170 | .065 | .027 | .003 | .000 | .000 | .000 | .000 |
| Medium Sand | .250-.500 (.354) | .040 | .044 | .044 | .066 | .108 | .123 | .136 | .225 | .201 | .192 | .185 | .185 | .137 | .078 | .008 | .001 | .000 | .000 | .001 |
| Coarse Sand | .500-1.0 (.707) | .094 | .102 | .095 | .109 | .151 | .198 | .145 | .187 | .247 | .231 | .232 | .225 | .243 | .172 | .018 | .003 | .000 | .000 | .001 |
| Very Coarse Sand | 1.0-2.0 (1.414) | .120 | .132 | .121 | .124 | .147 | .199 | .164 | .132 | .210 | .209 | .212 | .201 | .276 | .210 | .024 | .004 | .000 | .000 | .002 |
| Very Fine Gravel | 2.0-4.0 (2.83) | .058 | .063 | .058 | .055 | .058 | .080 | .072 | .030 | .046 | .051 | .052 | .049 | .073 | .062 | .009 | .002 | .000 | .000 | .001 |
| Fine Gravel | 4.0-8.0 (5.66) | .031 | .034 | .031 | .029 | .025 | .038 | .051 | .026 | .046 | .049 | .053 | .053 | .066 | .071 | .028 | .003 | .000 | .000 | .001 |
| Medium Gravel | 8.0-16.0 (11.31) | .025 | .027 | .025 | .023 | .016 | .026 | .024 | .029 | .044 | .008 | .053 | .043 | .042 | .066 | .060 | .021 | .000 | .000 | .002 |
| Coarse Gravel | 16.0-32.0 (22.63) | .025 | .027 | .025 | .023 | .016 | .009 | .008 | .041 | .018 | .000 | .000 | .000 | .065 | .097 | .098 | .107 | .002 | .000 | .003 |
| Very Coarse Gravel | 32.0-64.0 (45.26) | .043 | .047 | .043 | .040 | .028 | .016 | .015 | .007 | .017 | .000 | .000 | .025 | .030 | .215 | .703 | .713 | .000 | .056 | .795 |

Table 11

Grain Size Distribution at the Mentone Dam Site
As a Result of the Standard Project Flood and Reasonable Maximum Run Conditions

| Material | Grain Size Diameter (mm) | Distance from Dam (feet) | | | | | | | | | | | | | | | | | | | |
|--------------------|--------------------------|--------------------------|------|------|------|------|------|------|------|------|------|------|------|------|------|-------|-------|-------|-------|-------|------|
| | | 1400 | 1800 | 2200 | 2600 | 3000 | 4000 | 5000 | 6000 | 7000 | 7830 | 8180 | 8530 | 9005 | 9480 | 10430 | 12080 | 13580 | 15080 | 16580 | |
| Clay | <.016 | .149 | .140 | .131 | .119 | .099 | .069 | .048 | .022 | .015 | .022 | .015 | .007 | .000 | .000 | .000 | .000 | .000 | .000 | .000 | .001 |
| Silt | .016-.031 (.022) | .788 | .787 | .804 | .805 | .741 | .557 | .414 | .196 | .119 | .175 | .137 | .078 | .000 | .000 | .000 | .000 | .000 | .000 | .001 | .003 |
| Fine Sand | .125-.250 (.177) | .001 | .001 | .002 | .005 | .068 | .194 | .310 | .499 | .466 | .489 | .516 | .509 | .359 | .204 | .167 | .146 | .069 | .016 | .010 | .010 |
| Medium Sand | .250-.500 (.354) | .006 | .007 | .006 | .010 | .021 | .070 | .136 | .200 | .246 | .187 | .221 | .256 | .349 | .332 | .329 | .313 | .254 | .132 | .075 | .075 |
| Coarse Sand | .500-1.0 (.707) | .013 | .016 | .014 | .016 | .023 | .040 | .040 | .049 | .103 | .092 | .085 | .108 | .196 | .274 | .314 | .327 | .338 | .327 | .295 | .295 |
| Very Coarse Sand | 1.0-2.0 (1.414) | .017 | .020 | .017 | .019 | .023 | .036 | .026 | .017 | .029 | .023 | .018 | .025 | .056 | .099 | .111 | .128 | .199 | .284 | .310 | .310 |
| Very Fine | 2.0-4.0 (2.83) | .008 | .010 | .008 | .008 | .010 | .015 | .012 | .006 | .011 | .009 | .006 | .010 | .024 | .047 | .057 | .069 | .115 | .192 | .241 | .241 |
| Fine Gravel | 4.0-8.0 (5.66) | .004 | .005 | .005 | .004 | .004 | .008 | .006 | .002 | .003 | .002 | .001 | .002 | .004 | .009 | .008 | .008 | .014 | .027 | .036 | .036 |
| Medium Gravel | 8.0-16.0 (11.31) | .004 | .004 | .004 | .003 | .003 | .006 | .003 | .002 | .003 | .001 | .001 | .001 | .004 | .008 | .006 | .006 | .009 | .018 | .025 | .025 |
| Coarse Gravel | 16.0-32.0 (22.63) | .004 | .004 | .004 | .003 | .003 | .002 | .002 | .005 | .002 | .000 | .000 | .000 | .004 | .006 | .002 | .001 | .001 | .002 | .003 | .003 |
| Very Coarse Gravel | 32.0-64.0 (45.26) | .006 | .007 | .006 | .006 | .005 | .004 | .003 | .002 | .005 | .000 | .000 | .004 | .003 | .021 | .006 | .002 | .000 | .000 | .000 | .000 |

Table 12
Grain Size Distribution at The Mentone Dam Site
As a Result of Fifty Years of Mean Annual Floods Under Current Run Conditions

| Material | Grain Size Diameter (mm) | Distance from Dam (feet) | | | | | | | | | | Percentage in the Bed | | | | | | | | | |
|--------------------|--------------------------|--------------------------|------|------|------|------|------|------|------|------|------|-----------------------|------|------|------|-------|-------|-------|-------|-------|--|
| | | 1400 | 1800 | 2200 | 2600 | 3000 | 4000 | 5000 | 6000 | 7000 | 7830 | 8180 | 8530 | 9005 | 9480 | 10430 | 12080 | 13580 | 15080 | 16580 | |
| Clay | <.016 | .901 | .892 | .879 | .744 | .393 | .111 | .007 | .004 | .004 | .003 | .001 | .000 | .000 | .000 | .000 | .003 | .005 | .004 | | |
| Silt | .016-.031 (.022) | .006 | .018 | .052 | .213 | .564 | .749 | .078 | .010 | .011 | .009 | .007 | .004 | .001 | .000 | .000 | .008 | .014 | .009 | | |
| Fine Sand | .125-.250 (.177) | .001 | .001 | .001 | .001 | .025 | .091 | .600 | .130 | .123 | .138 | .166 | .215 | .305 | .284 | .230 | .193 | .063 | .079 | .059 | |
| Medium Sand | .250-.500 (.354) | .008 | .008 | .006 | .004 | .004 | .026 | .212 | .125 | .110 | .132 | .127 | .203 | .278 | .260 | .239 | .215 | .145 | .067 | .093 | |
| Coarse Sand | .500-1.0 (.707) | .019 | .019 | .014 | .009 | .004 | .011 | .070 | .100 | .081 | .105 | .126 | .167 | .192 | .196 | .199 | .195 | .172 | .119 | .115 | |
| Very Coarse Sand | 1.0-2.0 (1.414) | .024 | .024 | .018 | .011 | .004 | .008 | .024 | .079 | .055 | .083 | .113 | .145 | .156 | .163 | .177 | .186 | .165 | .151 | .132 | |
| Very Fine Gravel | 2.0-4.0 (2.83) | .012 | .012 | .009 | .005 | .002 | .002 | .004 | .020 | .006 | .020 | .045 | .059 | .033 | .081 | .102 | .106 | .097 | .096 | .086 | |
| Medium Gravel | 8.0-16.0 (11.31) | .005 | .005 | .004 | .003 | .001 | .001 | .001 | .105 | .171 | .100 | .082 | .041 | .007 | .003 | .002 | .045 | .066 | .059 | .074 | |
| Coarse Gravel | 16.0-32.0 (22.63) | .006 | .005 | .004 | .003 | .001 | .001 | .001 | .105 | .121 | .100 | .082 | .041 | .007 | .003 | .002 | .005 | .087 | .151 | .216 | |
| Very Coarse Gravel | 32.0-64.0 (45.26) | .011 | .009 | .007 | .005 | .002 | .001 | .002 | .181 | .209 | .173 | .141 | .070 | .012 | .005 | .004 | .008 | .150 | .260 | .170 | |

Table 13
 Simulated Depths of Deposited Sediment for
 Various Hydrologic Events and Watershed Conditions

| Flood/ Burn Conditions | Distance from Dam (feet) | | | | | | | | | | Total Vol. of Deposits (cu. yds. x 10 ⁶) | | | | | | | | | | |
|---|--------------------------|------|------|-------|-------|-------|-------|------|------|------|--|------|------|------|------|-------|-------|-------|-------|-------|-------|
| | 1400 | 1800 | 2200 | 2600 | 3000 | 4000 | 5000 | 6000 | 7000 | 7810 | | 8180 | 8530 | 9005 | 9480 | 10430 | 12080 | 13580 | 15080 | 16580 | |
| Mean Annual Flood, Current Burn | 0.31 | 0.34 | 0.59 | 1.98 | 0.06 | 0.08 | 0 | 0 | 0 | 0 | 0 | 0 | 0 | 0 | 0 | 0 | 0 | 0 | 0 | 0 | 0.44 |
| Mean Annual Flood, Reasonable Maximum Burn | 2.95 | 3.05 | 4.79 | 15.25 | 9.23 | 0.13 | 0.08 | 0.02 | 0.01 | 0 | 0 | 0 | 0 | 0 | 0 | 0 | 0 | 0 | 0 | 0 | 5.37 |
| Standard Project Flood, Current Burn | 0.41 | 0.34 | 0.39 | 0.42 | 0.62 | 1.16 | 1.24 | 2.61 | 1.90 | 0.54 | 0.85 | 0.58 | 0.44 | 1.10 | 0 | 0 | 0 | 0 | 0 | 0 | 2.03 |
| Standard Project Flood, Reasonable Maximum Burn | 5.10 | 4.30 | 4.93 | 4.94 | 5.53 | 6.80 | 7.28 | 9.67 | 7.34 | 4.36 | 5.67 | 4.59 | 5.67 | 5.26 | 4.93 | 7.80 | 3.85 | 0.80 | 0.18 | 0 | 14.71 |
| Fifty Years of Mean Annual Floods Under Current Burn Conditions | 6.48 | 6.37 | 8.44 | 12.85 | 29.73 | 34.16 | 10.34 | 0 | 0 | 0 | 0 | 0 | 1.35 | 3.25 | 4.83 | 2.12 | 0 | 0 | 0 | 0 | 24.6 |

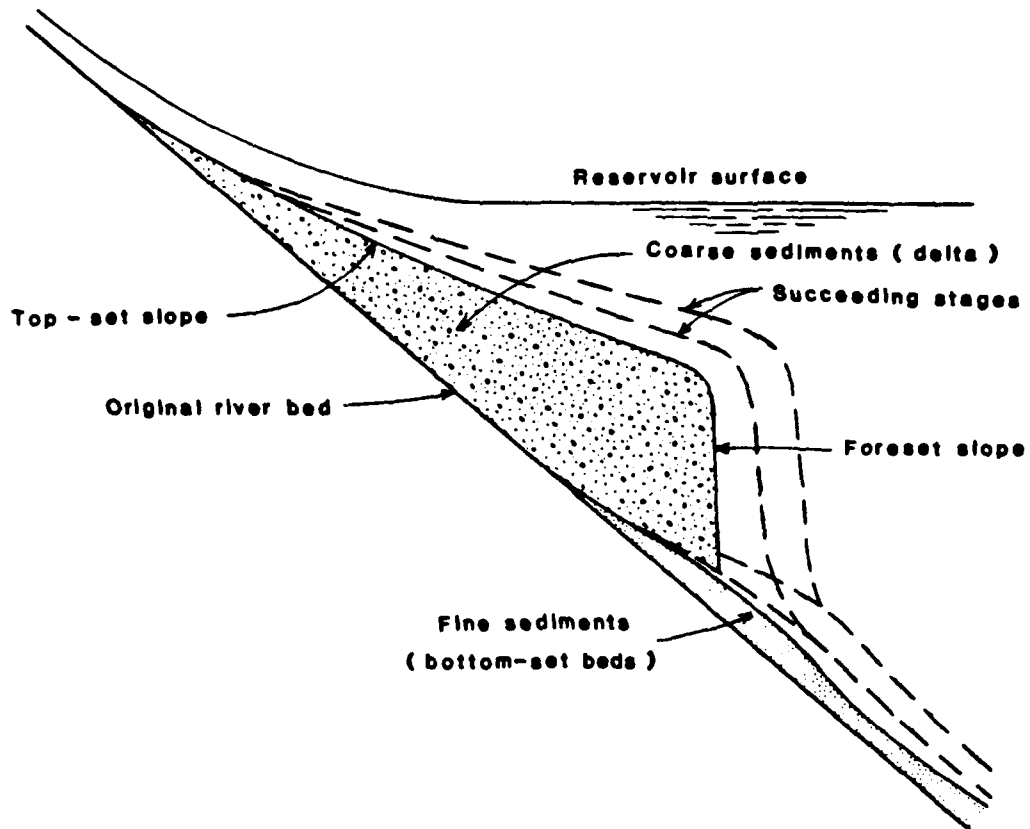

Figure 27. TYPICAL RESERVOIR DELTA FORM

CONCLUSIONS

Based on the data and results presented in this report, the following conclusions are made:

1. Accurate estimation of sediment production rates from watersheds in the Upper Santa Ana River drainage basin requires that past forest fire burn histories be considered. Periodic removal of protective vegetation by fires greatly increases runoff and subsequently, erosion rates.
2. The rates and severity of erosion throughout the Santa Ana River Basin are as varied as the topography and climate throughout the area. The upper reaches of the Santa Ana River along with its tributaries above Mentone are relatively steep pool and riffle type streams. The channel bed is armored with materials ranging from pebbles and cobbles up to large boulders. The prevalence of large-sized bed materials and armoring decreases rapidly below Mentone due to a large decrease in channel bed slope and the occurrence of various man-made controls.
3. For average annual floods, the estimated total sediment production rates for current burn and reasonable maximum burn forest conditions are 433,000 and 5,390,000 cubic yards per year, respectively.
4. For flows associated with a standard project flood event, the estimated total sediment production rates for current burn and reasonable maximum burn forest conditions are 2,026,000 and 11,709,000 cubic yards per storm, respectively. SPF sediment volumes could be as high as 44,000,000 cubic yards if large-scale bank caving and landsliding occur.
5. The calibrated HEC-6 computer model has exhibited good overall correlations between computed results and available data, based on numerous sediment surveys of the reservoir area at Hansen Dam in southern California. These correlations and comparisons consisted of the total amounts of deposited sediments, values of bed elevation change at selected cross sections, and the temporal as well as spatial distribution of various sizes of sediment materials deposited in the reservoir area. This study has also indicated that the contributing drainage basins of Hansen Dam and the proposed Mentone Dam are geomorphologically and hydrologically similar. It is thus concluded that the HEC-6 computer model provides a good predictive tool for simulating reservoir sedimentation processes.

6. Computed maximum delta thickness varied from about 2 feet to 15 feet for mean annual flood events and current burn and reasonable maximum burn forest conditions, respectively. A standard project flood would produce maximum delta deposits approximately 2.6 and 9.7 feet thick for current and reasonable maximum burn conditions. A thinner delta deposit is estimated for the SPF than for the mean annual flood, however, the spatial extent of the SPF pool-delta is much greater than the mean annual flood delta. Fifty years of average annual flows under current burn conditions created a maximum delta thickness of approximately 34 feet. An extrapolated 100-year maximum delta thickness of 40 to 50 feet was obtained.
7. The dynamic and physical characteristics of fluvial delta deposits on an ephemeral river are extremely complex. Added complications are experienced when the reservoir remains dry for long periods of time and is operated primarily for flood control for large events. Therefore, the quantitative results presented in this report should be used cautiously and viewed as qualitative in nature.
8. Based on the results of this investigation, sufficient sediment deposition will occur within Mentone Reservoir (over the project life of the dam) to cause possible reductions in existing groundwater infiltration rates in the immediate vicinity of the Reservoir. It is difficult to evaluate these effects because there are several offsetting factors occurring simultaneously that will tend to increase infiltration, such as increased heads of water within the flood pool, and storage and retention of flood waters for much longer periods over a larger effective area. Most flood waters currently flow through the system and cannot be stored in large volumes for recharge purposes.
9. Alternate methods of reservoir operation, outlet design, reservoir bottom maintenance programs, and relocation of spreading basins should be investigated as possible methods for minimizing the impacts of sediment deposition on groundwater recharge.

REFERENCES

1. Billingsley, G. A. and B. A. Anderson. 1976. Surface water supply of the United States, 1966-70. Part II, Pacific Slope Basins in California. Volume 1, Basins from Tijuana River to Santa Maria River. U.S.G.S. Water-Supply Paper 2128. Washington, D.C.
2. Brown, J. A. H. 1972. Hydrologic Effects of A Brushfire In A Catchment In New South Wales. Journal of Hydrology, Vol. 15, pages 77-96.
3. Brownlie, W. R. and B. D. Taylor. 1981. Sediment management for southern California mountains, coastal plains and shoreline. Part C, Coastal sediment delivery by major rivers in southern California. EQL Report No. 17-C. Environmental Quality Laboratory, California Institute of Technology, Pasadena, California.
4. California. Department of Water Resources. 1966. Upper Santa Ana River drainage area land and water use survey, 1964. Bulletin No. 71-64. Sacramento, California.
5. California. Department of Water Resources. 1970. Meeting water demands in the Bunker Hill - San Timoteo area. Bulletin No. 104-5. Sacramento, California.
6. California. Department of Water Resources. 1977. Upper Santa Ana River drainage area land use study, 1975. Sacramento, California.
7. California. Department of Water Resources. 1978. Updated hydrologic conditions in the Bunker Hill - San Timoteo area. Letter report. Los Angeles, California.
8. Dutcher, L. C. and W. L. Burnham. 1960. Geology and groundwater hydrology of the Mill Creek area, San Bernardino County, California. U.S.G.S. Open-file report. Washington, D.C.
9. Dutcher, L. C. and A. A. Garrett. 1963. Geologic & hydrologic features of the San Bernardino area, California - with special reference to underflow across the San Jacinto fault. U.S.G.S. Water Supply Paper 1419. Washington, D.C.
10. Fall, E. W. 1981. Sediment management for southern California mountains, coastal plains and shoreline. Part A, Regional geological history. EQL Report No. 17-A. Environmental Quality Laboratory, California Institute of Technology, Pasadena, California.
11. Goss, D. W. et al 1973. Fate of suspended sediment during basin recharge. Water Resources Research 9. (3):668-675.
12. Grover, B. L., F. K. Aljibury, and D. D. Baier. 1968. Effects of surface sediments on groundwater recharge. California Agriculture 22(4):12-14.

13. Hendricks, E. L. 1964. Compilation of records of surface waters of the United States, October 1950 to September 1960. Part II, Pacific Slope Basins in California. U.S.G.S. Water Supply Paper 1735. Washington, D.C.
14. Knott, J. M. 1980. Reconnaissance assessment of erosion and sedimentation in the Canada de los Alamos Basin, Los Angeles and Ventura Counties, California. U.S.G.S. Water Supply Paper 2061. Washington, D.C.
15. Lustig, L. K. 1965. Sediment yield of the Castaic watershed, western Los Angeles County, California - a quantitative geomorphic approach. U.S.G.S. Professional Paper 422-F. Washington, D.C.
16. Moreland, J. A. 1972. Artificial recharge in Upper Santa Ana Valley, Southern California. U.S.G.S. Open-file report. Menlo Park, California.
17. Nelson, L. M. 1970. A method of estimating annual suspended-sediment discharge. U.S.G.S. Professional Paper 700-C. Washington, D.C.
18. Price, John L. and Associates. 1972. Environmental analysis of the Mentone Dam alternative to the Santa Ana River plan. Whittier, California.
19. Retelas, James G. 1980. Order 3 soil resource inventory of San Bernardino National Forest California. Draft. U.S.D.A. - Forest Service. Washington, D.C.
20. Rowe, P. B., C. M. Countryman, and H. C. Storey. 1949. Probable peak discharges and erosion rates from southern California watersheds as influenced by fire. U.S.D.A. - Forest Service, California Forest and Range Exp. Station, UCB, Berkeley, California.
21. Rowe, P. B., C. M. Countryman, and H. C. Storey. 1954. Hydrologic analysis used to determine effects of fire on peak discharges and erosion rates in southern California watersheds. U.S.D.A. - Forest Service, California Forest and Range Exp. Station, UCB, Berkeley, California.
22. Scalmanini, Joseph C. and Verne H. Scott. 1979. Design and operational criteria for artificial groundwater recharge facilities. Water Sci. and Eng. Paper No. 2009. LAWR, University of California. Davis.
23. Schaefer, D. H. and J. W. Warner. 1975. Artificial recharge in the Upper Santa Ana River area, San Bernardino County, California. U.S.G.S. Water Resource Investigation 15-75. Washington, D.C.
24. Scott, M. and R. P. Williams. 1978. Erosion and sediment yields in the Transverse Ranges, Southern California. U.S.G.S. Professional Paper 1030.

25. Sidler, W. A. 1957 (updated 1972). Floods of the past; an assemblage of documentary observations with particular reference to the San Bernardino Valley and environs. San Bernardino County Flood Control District, San Bernardino, California.
26. Taylor, B. D. 1979. Sediment management for southern California mountains, coastal plains and shoreline. Draft final report. Appendix B, Inland sediment movements by natural processes. Environmental Quality Laboratory California Institute of Technology, Pasadena, California.
27. Taylor, D., M. Brown, and W. R. Brownlie. 1977. Sediment management for southern California mountains, coastal plains and shoreline. Progress Report No. 3. Environmental Quality Laboratory, California Institute of Technology, Pasadena, California.
28. U.S. Army Corps of Engineers. The Hydrologic Engineering Center. 1977. HEC-6, Scour and Deposition In Rivers and Reservoirs. Users Manual, The Hydrologic Engineering Center. Davis, California.
29. U.S. Army Corps of Engineers. The Hydrologic Engineering Center. 1981. Guidelines for the Calibration and Application of Computer Program HEC-6. Training Document No. 13. The Hydrologic Engineering Center. Davis, California.
30. U.S. Army Corps of Engineers. Los Angeles District. 1980. Santa Ana River; Phase I GDM on the Santa Ana River main stem including Santiago Creek. Main report and supplemental environmental impact statement. Los Angeles, California.
31. U.S. Department of Agriculture. Agricultural Research Service. 1975. Present and prospective technology for predicting sediment yields and sources; proceedings of a sediment-yield workshop, USDA Sedimentation Laboratory. Oxford, Mississippi. November 28-30, 1972. ARS-S-40.
32. U.S. Department of Agriculture. Agricultural Research Service. 1978. Sediment deposition in U.S. reservoirs; summary of data reported through 1975. Misc. Pub. No. 1362. Washington, D.C.
33. U.S. Department of Agriculture. Soil Conservation Service. 1971. National Engineering Handbook "Section 3, Sedimentation" Pages 6-14. Washington, D.C.
34. U.S. Department of Agriculture. Soil Conservation Service. 1980. Soil survey of San Bernardino County, Southwestern part, California. Washington, D.C.
35. U.S. Department of the Army. Office of the Chief of Engineers. 1977. Review report on the Santa Ana River main stem - including Santiago Creek and Oak Street Drain for flood control and allied purposes. Final environmental statement. Washington, D.C.

36. Vanoni, Vito A. 1975. Sedimentation Engineering. American Society of Civil Engineers. New York, New York.
37. Watson, K. K. and F. D. Whisler. 1977. Profile desaturation during sediment deposition in a groundwater recharge trench. Journal of Hydrology 33(3/4):397-401.
38. Wells, J. V. 1960. Compilation of records of surface waters of the United States through September 1950. Part II-A, Pacific Slope Basins in California except Central Valley. U.S.G.S. Water Supply Paper 1315-B. Washington, D.C.
39. Wells, Wade G. 1981. Erosion and Sediment Transport In Pacific Rim Steeplands. I.A.H.S. Public Notice 132. Oristchurch, New Zealand.

APPENDIX

**Peak Discharge Rate Following Watershed Burning
and Annual Erosion Rates Following Burning**

(from Rowe, Contryman and Story, 1954)

Santa Ana River, PWI = 22

Drainage area: 140.02 sq. mi. 70-Yr Mean Annual Precipitation 32.9 in.

A. Peak Discharge Rates Following Burning

| Number of Events Per Year | Years after burning | | | | | | | |
|------------------------------------|---|------|------|------|------|------|----|----------|
| | 1 | 2 | 3 | 7 | 15 | 30 | 70 | (Normal) |
| | (Cubic feet per second per square mile) | | | | | | | |
| 15.0 | 2.17 | 0.63 | 0.48 | 0.41 | 0.38 | 0.37 | | 0.37 |
| 5.50 | 5.63 | 2.03 | 1.63 | 1.39 | 1.31 | 1.26 | | 1.26 |
| 1.59 | 13.5 | 6.15 | 4.99 | 4.16 | 3.90 | 3.75 | | 3.75 |
| 1.42 | 22.6 | 12.2 | 9.99 | 8.36 | 7.77 | 7.47 | | 7.40 |
| .537 | 33.5 | 21.0 | 17.5 | 14.6 | 13.6 | 12.9 | | 12.8 |
| .279 | 43.6 | 29.0 | 24.7 | 20.5 | 19.1 | 18.2 | | 18.0 |
| .168 | 52.9 | 37.2 | 31.8 | 26.7 | 24.8 | 23.9 | | 23.4 |
| .112 | 60.5 | 43.8 | 37.9 | 31.8 | 29.6 | 28.5 | | 27.9 |
| .136 | 71.5 | 53.4 | 46.8 | 39.9 | 37.1 | 35.4 | | 34.7 |
| .076 | 87.4 | 67.8 | 59.8 | 51.3 | 47.7 | 45.5 | | 44.6 |
| .049 | 103 | 81.4 | 72.6 | 62.8 | 58.4 | 56.2 | | 54.6 |
| .032 | 117 | 93.6 | 84.1 | 72.6 | 68.2 | 65.6 | | 63.7 |
| .023 | 130 | 106 | 96.8 | 83.6 | 78.4 | 75.5 | | 73.3 |
| .0167 | 144 | 118 | 108 | 94.1 | 88.3 | 85.0 | | 82.5 |
| .0121 | 158 | 132 | 120 | 106 | 100 | 95.5 | | 92.7 |
| .0169 | 180 | 151 | 138 | 122 | 116 | 110 | | 107 |
| .0106 | 208 | 178 | 163 | 145 | 136 | 131 | | 127 |
| .0075 | 235 | 203 | 187 | 166 | 158 | 150 | | 146 |
| .0051 | 262 | 226 | 210 | 188 | 178 | 170 | | 165 |
| .0035 | 226 | 249 | 231 | 207 | 197 | 189 | | 182 |
| .0028 | 310 | 270 | 252 | 228 | 216 | 208 | | 200 |
| .0021 | 333 | 292 | 272 | 246 | 233 | 225 | | 216 |
| .0007 | 347 | 306 | 286 | 259 | 245 | 236 | | 227 |
| .0100 | 350 | 307 | 286 | 261 | 247 | 238 | | 229 |

B. Annual Erosion Rates Following Burning
(in cubic yards per square mile per year)

| 1 | Years after burning | | | | | | | |
|--------|---------------------|-------|-------|-------|-------|-------|-------|-------|
| | 2 | 3 | 4 | 5 | 6 | 7 | 8 | 10 |
| | (Normal) | | | | | | | |
| 25,020 | 9,170 | 6,120 | 4,450 | 3,340 | 2,640 | 1,950 | 1,440 | 1,390 |

Normal annual watershed sediment production rate = 195,000 yards³/yr.

Santa Ana River, PWI = 19
Mill Creek Wash

Drainage area: 4.25 sq. mi. 70-Yr Mean Annual Precipitation 21.8 in.

A. Peak Discharge Rates Following Burning

| Number of Events Per Year | Years after burning | | | | | | | |
|------------------------------------|---------------------|------|------|------|------|------|------|----------|
| | 1 | 2 | 3 | 7 | 15 | 30 | 70 | (Normal) |
| | 13.71 | 2.25 | 0.41 | 0.24 | 0.15 | 0.12 | 0.11 | 0.10 |
| | 4.42 | 17.3 | 4.00 | 2.53 | 1.64 | 1.35 | 1.19 | 1.18 |
| | 1.70 | 36.8 | 11.9 | 7.92 | 5.20 | 4.34 | 3.81 | 3.77 |
| | 1.88 | 53.4 | 16.9 | 15.0 | 9.94 | 8.17 | 7.24 | 7.10 |
| | .90 | 70.2 | 34.7 | 25.2 | 16.8 | 13.9 | 12.3 | 11.9 |
| | .540 | 84.3 | 45.8 | 34.2 | 23.4 | 19.4 | 17.3 | 16.6 |
| | .375 | 95.8 | 55.8 | 42.4 | 29.7 | 25.0 | 22.0 | 21.2 |
| | .269 | 106 | 64.5 | 50.0 | 35.3 | 30.0 | 26.7 | 25.4 |
| | .352 | 121 | 77.4 | 61.8 | 44.5 | 37.8 | 33.6 | 32.0 |
| | .224 | 142 | 95.5 | 77.2 | 56.9 | 49.0 | 44.0 | 41.5 |
| | .150 | 161 | 112 | 91.8 | 69.0 | 59.8 | 53.7 | 50.7 |
| | .109 | 161 | 128 | 107 | 81.3 | 70.4 | 63.8 | 60.2 |
| | .081 | 200 | 145 | 122 | 93.1 | 81.3 | 73.7 | 69.5 |
| | .060 | 219 | 161 | 137 | 106 | 92.8 | 84.1 | 79.3 |
| | .049 | 237 | 176 | 151 | 117 | 104 | 94.1 | 88.8 |
| | .0695 | 265 | 202 | 173 | 137 | 122 | 110 | 104 |
| | .0415 | 301 | 232 | 202 | 162 | 145 | 131 | 124 |
| | .0272 | 341 | 269 | 235 | 191 | 172 | 156 | 147 |
| | .0174 | 383 | 304 | 268 | 222 | 200 | 183 | 173 |
| | .0109 | 423 | 340 | 301 | 250 | 225 | 208 | 194 |
| | .0079 | 466 | 377 | 335 | 283 | 254 | 234 | 219 |
| | .0052 | 506 | 411 | 368 | 312 | 281 | 259 | 242 |
| | .0014 | 531 | 436 | 392 | 333 | 299 | 276 | 258 |
| | .0100 | 538 | 438 | 394 | 337 | 303 | 279 | 261 |

B. Annual Erosion Rates Following Burning
(in cubic yards per square mile per year)

| 1 | Years after burning | | | | | | | |
|---------|---------------------|--------|--------|--------|-------|-------|-------|-------------|
| | 2 | 3 | 4 | 5 | 6 | 7 | 8 | 10 (Normal) |
| 119,450 | 41,580 | 27,220 | 18,900 | 13,610 | 9,830 | 6,620 | 4,020 | 3,780 |

Normal annual watershed sediment production rate = 16,100 yards³/yr.

Santa Ana River, FWI = 21
Morton Canyon

Drainage area: 2.46 sq. mi. 70-Yr Mean Annual Precipitation 21.9 in.

A. Peak Discharge Rates Following Burning

| Number of Events Per Year | Years after burning | | | | | | | |
|------------------------------------|---|------|------|------|------|------|----------|--|
| | 1 | 2 | 3 | 7 | 15 | 30 | (Normal) | |
| | (Cubic feet per second per square mile) | | | | | | | |
| 13.71 | 3.65 | 0.63 | 0.39 | 0.26 | 0.22 | 0.20 | 0.80 | |
| 4.42 | 15.2 | 3.71 | 2.44 | 1.68 | 1.42 | 1.29 | 1.28 | |
| 1.70 | 32.5 | 11.2 | 7.77 | 5.42 | 4.70 | 4.24 | 4.20 | |
| 1.88 | 47.3 | 20.5 | 14.8 | 10.5 | 8.99 | 8.18 | 8.10 | |
| .90 | 64.3 | 33.4 | 25.2 | 17.9 | 15.5 | 14.0 | 13.7 | |
| .540 | 82.1 | 46.6 | 35.9 | 25.9 | 22.1 | 20.2 | 19.6 | |
| .375 | 96.8 | 58.5 | 45.6 | 33.5 | 28.7 | 26.0 | 25.2 | |
| .269 | 110 | 68.7 | 54.3 | 39.9 | 34.2 | 31.2 | 30.0 | |
| .352 | 128 | 83.6 | 67.5 | 50.0 | 42.9 | 39.2 | 37.3 | |
| .224 | 153 | 105 | 86.0 | 64.7 | 56.0 | 51.2 | 48.3 | |
| .150 | 178 | 124 | 103 | 78.5 | 68.4 | 62.5 | 59.0 | |
| .109 | 201 | 144 | 121 | 92.0 | 80.9 | 73.9 | 69.7 | |
| .081 | 223 | 162 | 138 | 106 | 93.6 | 84.8 | 80.0 | |
| .060 | 247 | 182 | 155 | 120 | 106 | 96.5 | 91.0 | |
| .049 | 268 | 200 | 171 | 135 | 119 | 108 | 102 | |
| .0695 | 303 | 231 | 198 | 157 | 140 | 126 | 119 | |
| .0415 | 343 | 265 | 228 | 185 | 164 | 150 | 140 | |
| .0272 | 389 | 305 | 267 | 216 | 193 | 177 | 165 | |
| .0174 | 431 | 340 | 299 | 246 | 220 | 203 | 188 | |
| .0109 | 466 | 374 | 330 | 274 | 242 | 226 | 209 | |
| .0079 | 508 | 408 | 363 | 305 | 270 | 252 | 233 | |
| .0052 | 544 | 439 | 394 | 330 | 295 | 274 | 254 | |
| .0014 | 572 | 467 | 416 | 351 | 313 | 292 | 270 | |
| .0100 | 581 | 471 | 422 | 356 | 318 | 296 | 274 | |

B. Annual Erosion Rates Following Burning
(in cubic yards per square mile per year)

| Years after burning | | | | | | | | | |
|---------------------|--------|--------|--------|--------|-------|-------|-------|----------|--|
| 1 | 2 | 3 | 4 | 5 | 6 | 7 | 8 | (Normal) | |
| 126,000 | 43,920 | 28,440 | 19,800 | 14,040 | 9,720 | 6,480 | 3,850 | 3,600 | |

Normal annual watershed sediment production rate = 8,850 yards³/yr.

Santa Ana River, PWI = 20
Mill Creek

Drainage area: 43.21 sq. mi. 70-Yr Mean Annual Precipitation 34.1 in.

A. Peak Discharge Rates Following Burning

| Number of Events Per Year | Years after burning | | | | | | | |
|---|---------------------|------|------|------|------|------|----------------|--|
| | 1 | 2 | 3 | 7 | 15 | 30 | 70 (Normal) | |
| (Cubic feet per second per square mile) | | | | | | | | |
| 15.0 | 3.61 | 0.95 | 0.71 | 0.58 | 0.54 | 0.51 | 0.51 | |
| 5.50 | 8.30 | 2.71 | 2.08 | 1.72 | 1.60 | 1.52 | 1.52 | |
| 1.59 | 15.0 | 6.37 | 4.98 | 4.06 | 3.77 | 3.56 | 3.56 | |
| 1.42 | 25.9 | 13.2 | 10.5 | 8.47 | 7.74 | 7.37 | 7.30 | |
| .537 | 37.6 | 22.2 | 18.1 | 14.5 | 13.3 | 12.5 | 12.4 | |
| .279 | 48.4 | 31.0 | 25.7 | 20.6 | 18.8 | 18.0 | 17.6 | |
| .168 | 58.4 | 39.4 | 33.1 | 26.9 | 24.6 | 23.3 | 22.8 | |
| .112 | 66.9 | 46.4 | 39.3 | 32.2 | 29.5 | 27.8 | 27.3 | |
| .136 | 79.0 | 57.1 | 49.2 | 40.4 | 36.9 | 34.9 | 34.2 | |
| .076 | 96.6 | 72.7 | 62.9 | 52.3 | 48.3 | 45.6 | 44.3 | |
| .049 | 114 | 87.4 | 77.0 | 64.4 | 59.5 | 56.2 | 54.6 | |
| .032 | 130 | 102 | 90.3 | 76.1 | 70.3 | 66.4 | 64.5 | |
| .023 | 147 | 116 | 104 | 87.9 | 81.2 | 76.7 | 74.5 | |
| .0167 | 162 | 130 | 117 | 99.7 | 92.1 | 87.0 | 84.5 | |
| .0121 | 180 | 144 | 130 | 112 | 104 | 97.9 | 95.0 | |
| .0169 | 202 | 166 | 150 | 130 | 121 | 114 | 110 | |
| .0106 | 230 | 191 | 173 | 151 | 141 | 133 | 128 | |
| .0075 | 262 | 221 | 201 | 176 | 164 | 155 | 149 | |
| .0051 | 294 | 248 | 228 | 201 | 187 | 177 | 170 | |
| .0035 | 323 | 274 | 251 | 223 | 208 | 197 | 189 | |
| .0028 | 353 | 301 | 276 | 247 | 230 | 217 | 209 | |
| .0021 | 382 | 327 | 302 | 270 | 252 | 240 | 229 | |
| .0007 | 403 | 345 | 321 | 287 | 267 | 255 | 243 | |
| .0100 | 410 | 351 | 326 | 291 | 272 | 259 | 247 | |

B. Annual Erosion Rates Following Burning
(in cubic yards per square mile per year)

| | Years after burning | | | | | | | | | |
|--|---------------------|--------|-------|-------|-------|-------|-------|-------|----------------|--|
| | 1 | 2 | 3 | 4 | 5 | 6 | 7 | 8 | 10 (Normal) | |
| | 30,390 | 10,930 | 7,240 | 5,250 | 3,830 | 2,980 | 2,130 | 1,480 | 1,420 | |

Normal annual watershed sediment production rate = 61,400 yards³/yr.

Santa Ana River, PWI = 25
Plunge Creek

Drainage area: 16.91 sq. mi. 70-Yr Mean Annual Precipitation 34.8 in.

A. Peak Discharge Rates Following Burning

| Number of Events Per Year | Years after burning | | | | | | | |
|------------------------------------|---|------|------|------|------|------|----------------|--|
| | 1 | 2 | 3 | 7 | 15 | 30 | 70 (Normal) | |
| | (Cubic feet per second per square mile) | | | | | | | |
| 13.71 | 9.91 | 2.22 | 1.50 | 1.12 | 0.99 | 0.92 | 0.92 | |
| 4.42 | 25.4 | 6.99 | 4.96 | 3.73 | 3.33 | 3.11 | 3.08 | |
| 1.70 | 37.8 | 13.8 | 9.99 | 7.36 | 6.52 | 6.04 | 5.98 | |
| 1.88 | 48.1 | 21.6 | 15.9 | 11.7 | 10.2 | 9.35 | 9.26 | |
| .90 | 59.3 | 31.5 | 24.1 | 17.5 | 15.3 | 14.0 | 13.7 | |
| .540 | 68.2 | 39.6 | 31.0 | 22.9 | 20.0 | 18.4 | 17.9 | |
| .375 | 79.3 | 48.8 | 38.4 | 28.9 | 25.1 | 22.9 | 22.2 | |
| .269 | 87.1 | 55.5 | 44.5 | 33.4 | 29.0 | 26.7 | 25.7 | |
| .352 | 98.0 | 65.1 | 53.3 | 40.3 | 35.3 | 32.2 | 31.0 | |
| .224 | 114 | 79.1 | 65.6 | 50.2 | 44.0 | 40.5 | 38.6 | |
| .150 | 130 | 92.5 | 77.7 | 60.5 | 53.5 | 48.8 | 46.5 | |
| .109 | 144 | 105 | 88.9 | 69.5 | 62.0 | 56.6 | 53.9 | |
| .081 | 161 | 119 | 102 | 80.0 | 71.3 | 65.1 | 62.0 | |
| .060 | 175 | 131 | 113 | 89.5 | 80.4 | 74.1 | 69.9 | |
| .049 | 191 | 145 | 126 | 100 | 90.0 | 83.0 | 78.3 | |
| .0695 | 217 | 168 | 145 | 118 | 106 | 97.5 | 92.0 | |
| .0415 | 245 | 192 | 168 | 138 | 124 | 114 | 108 | |
| .0272 | 279 | 223 | 197 | 163 | 147 | 136 | 128 | |
| .0174 | 312 | 251 | 223 | 187 | 169 | 157 | 147 | |
| .0109 | 342 | 279 | 248 | 210 | 188 | 177 | 165 | |
| .0079 | 378 | 309 | 277 | 236 | 212 | 199 | 186 | |
| .0052 | 406 | 335 | 302 | 257 | 233 | 218 | 204 | |
| .0014 | 424 | 354 | 319 | 273 | 247 | 232 | 217 | |
| .0100 | 433 | 359 | 321 | 277 | 251 | 235 | 220 | |

B. Annual Erosion Rates Following Burning
(in cubic yards per square mile per year)

| 1 | Years after burning | | | | | | | | 10 (Normal) |
|---------|---------------------|--------|--------|--------|-------|-------|-------|-------|----------------|
| | 2 | 3 | 4 | 5 | 6 | 7 | 8 | | |
| 108,470 | 37,860 | 24,750 | 17,470 | 12,380 | 9,100 | 6,190 | 3,860 | 3,640 | |

Normal annual watershed sediment production rate = 61,500 yards³/yr.

Santa Ana River PWI = 24
Oak Creek

Drainage area: 3.66 sq. mi. 70-Yr Mean Annual Precipitation 22.9 in.

A. Peak Discharge Rates Following Burning

| Number of Events Per Year | Years after burning | | | | | | | 70 (Normal) |
|---|---------------------|------|------|------|------|------|------|----------------|
| | 1 | 2 | 3 | 7 | 15 | 30 | | |
| (Cubic feet per second per square mile) | | | | | | | | |
| 13.71 | 5.99 | 1.12 | 0.67 | 0.43 | 0.35 | 0.31 | 0.30 | |
| 4.42 | 18.6 | 4.40 | 2.82 | 1.88 | 1.56 | 1.39 | 1.38 | |
| 1.70 | 27.1 | 8.88 | 6.00 | 4.05 | 3.42 | 3.03 | 3.00 | |
| 1.88 | 34.1 | 14.1 | 9.90 | 6.66 | 5.59 | 5.00 | 4.90 | |
| .90 | 41.6 | 20.9 | 15.4 | 10.4 | 8.74 | 7.83 | 7.60 | |
| .540 | 48.2 | 26.6 | 20.1 | 14.0 | 11.8 | 10.6 | 10.2 | |
| .375 | 54.3 | 32.1 | 24.6 | 17.7 | 15.0 | 13.4 | 12.9 | |
| .269 | 59.3 | 36.6 | 28.6 | 20.7 | 17.6 | 16.0 | 15.2 | |
| .352 | 66.2 | 43.0 | 34.6 | 25.2 | 21.7 | 19.6 | 18.7 | |
| .224 | 77.1 | 52.8 | 43.1 | 32.3 | 28.0 | 25.5 | 24.1 | |
| .150 | 87.9 | 61.7 | 51.2 | 39.1 | 34.1 | 31.2 | 29.4 | |
| .109 | 97.6 | 70.0 | 59.0 | 45.5 | 40.0 | 36.6 | 34.5 | |
| .081 | 108 | 79.6 | 67.6 | 52.4 | 46.4 | 42.4 | 40.0 | |
| .060 | 118 | 87.7 | 75.0 | 58.8 | 52.4 | 47.9 | 45.2 | |
| .049 | 129 | 97.3 | 84.0 | 66.0 | 59.4 | 54.3 | 51.2 | |
| .0695 | 146 | 112 | 97.1 | 78.3 | 70.4 | 64.3 | 60.7 | |
| .0415 | 170 | 133 | 116 | 95.2 | 84.9 | 78.2 | 73.8 | |
| .0272 | 197 | 157 | 139 | 115 | 103 | 95.1 | 89.7 | |
| .0174 | 228 | 185 | 163 | 137 | 123 | 114 | 107 | |
| .0109 | 256 | 208 | 185 | 156 | 140 | 132 | 123 | |
| .0079 | 290 | 237 | 213 | 182 | 163 | 153 | 143 | |
| .0052 | 330 | 272 | 246 | 211 | 189 | 178 | 166 | |
| .0014 | 357 | 295 | 266 | 228 | 206 | 194 | 181 | |
| .0100 | 364 | 300 | 270 | 233 | 211 | 198 | 165 | |

B. Annual Erosion Rates Following Burning
(in cubic yards per square mile per year)

| 1 | Years after burning | | | | | | | 10 (Normal) |
|--------|---------------------|--------|-------|-------|-------|-------|-------|----------------|
| | 2 | 3 | 4 | 5 | 6 | 7 | 8 | |
| 52,150 | 18,200 | 11,900 | 8,400 | 6,040 | 4,380 | 2,980 | 1,860 | 1,750 |

Normal annual watershed sediment production rate = 6,400 yards³/yr.

FILMED
0-8