

AD-A172 417

A RODENT WATER DISPENSING SYSTEM FOR USE IN HYPOBARIC  
CHAMBERS(U) ARMY RESEARCH INST OF ENVIRONMENTAL  
MEDICINE NATICK MA J A DEVINE ET AL. 04 SEP 86

1/1

UNCLASSIFIED

USARIEN-MSS-86

F/G 13/4

NL



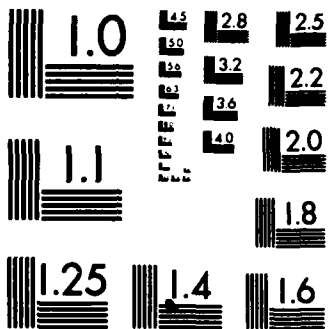

MICROCOPY RESOLUTION TEST CHART  
NATIONAL BUREAU OF STANDARDS-1963-A

UNCLASSIFIED  
SECURITY CLASSIFICATION OF TITLE

AD-A172 417

Form Approved  
OMB No 0704-0188  
Exp Date Jun 30, 1986

1a. REPORT SECURITY CLASSIFICATION <b>UNCLASSIFIED</b>		10. RESTRICTIVE MARKINGS	
2a. SECURITY CLASSIFICATION AUTHORITY		3. DISTRIBUTION/AVAILABILITY OF REPORT Approved for public release, distribution is unlimited.	
2b. DECLASSIFICATION/DOWNGRADING SCHEDULE		5. MONITORING ORGANIZATION REPORT NUMBER(S)	
4. PERFORMING ORGANIZATION REPORT NUMBER(S) M55-86		7a. NAME OF MONITORING ORGANIZATION	
6a. NAME OF PERFORMING ORGANIZATION U.S. Army Rsch Inst of Env Med Natick, MA 01760-5007	6b. OFFICE SYMBOL (if applicable) SGRD-UE-AR	7b. ADDRESS (City, State, and ZIP Code)	
6c. ADDRESS (City, State, and ZIP Code) U.S. Army Rsch Inst of Env Med Natick, MA 01760-5007		9. PROCUREMENT INSTRUMENT IDENTIFICATION NUMBER	
8a. NAME OF FUNDING/SPONSORING ORGANIZATION	8b. OFFICE SYMBOL (if applicable)	10. SOURCE OF FUNDING NUMBERS	
8c. ADDRESS (City, State, and ZIP Code)		PROGRAM ELEMENT NO.	PROJECT NO. 3M161102BS1D
		TASK NO. S10/CA	WORK UNIT ACCESSION NO. 002
11. TITLE (Include Security Classification) A Rodent Water Dispensing System for Use in Hypobaric Chambers			
12. PERSONAL AUTHOR(S) James A. Devine and Allen Cymerman			
13a. TYPE OF REPORT Manuscript	13b. TIME COVERED FROM _____ TO _____	14. DATE OF REPORT (Year, Month, Day) 86/09/04	15. PAGE COUNT 17
16. SUPPLEMENTARY NOTATION			
17. COSATI CODES		18. SUBJECT TERMS (Continue on reverse if necessary and identify by block number)	
FIELD	GROUP	SUB-GROUP	
19. ABSTRACT (Continue on reverse if necessary and identify by block number) A water dispensing system for rodents has been developed for use in chronic research studies involving hypobaric chambers. The system removes an existing problem that has restricted long-term animal exposures due to limitations inherent in the typical water supply bottles. It consists of an external reservoir, connected to water feeding valves located inside the altitude simulation facility,			
20. DISTRIBUTION/AVAILABILITY OF ABSTRACT <input checked="" type="checkbox"/> UNCLASSIFIED/UNLIMITED <input type="checkbox"/> SAME AS RPT. <input type="checkbox"/> DTIC USERS		21. ABSTRACT SECURITY CLASSIFICATION UNCLASSIFIED	
22a. NAME OF RESPONSIBLE INDIVIDUAL James A. Devine		22b. TELEPHONE (Include Area Code) (617) 651-4820	22c. OFFICE SYMBOL SGRD-UE-AR

DTIC FILE COPY

DTIC ELECTED  
S OCT 2 1986  
A

86-10-61-228

SUMMARY

A water dispensing system for rodents has been developed for use in chronic research studies involving hypobaric chambers. The system removes an existing problem that has restricted long-term animal exposures due to limitations inherent in the typical water supply bottles. It consists of an external reservoir, connected to water feeding valves located inside the altitude simulation facility.

Accession For	<input checked="" type="checkbox"/>
NTIS GRA&I	<input type="checkbox"/>
DTIC TAB	<input type="checkbox"/>
Unannounced	<input type="checkbox"/>
Justification	
By	
Distribution/	
Availability Codes	
Dist	

A-1



Running Head: Rodent Water Dispensing System

Title: A Rodent Water Dispensing System for Use in Hypobaric Chambers

Authors: James A. Devine, A.M.E. and Allen Cymerman, Ph.D.

Institute: U.S. Army Research Institute of Environmental Medicine  
Natick, Massachusetts 01760-5007

## A RODENT WATER DISPENSING SYSTEM FOR USE IN HYPOBARIC CHAMBERS

### INTRODUCTION

Hypobaric chambers are facilities that simulate the earth's atmospheric conditions through the reduction of barometric pressure using vacuum pumps (1-5). Any desired pressure can be produced and controlled precisely and conveniently with the exclusion of all complicating influences. Many hypobaric chambers exist that provide realistic simulations of barometric pressure, temperature, and relative humidity. Such facilities have been employed to great advantages in the field of medical research for the study of adaptive life processes of humans and animals (6), in industry for environmentally stressing materials and hardware, and for flight crew and space mission training (7).

This report describes a water dispensing system for rodents that will permit chronic research studies involving hypobaric chambers.

One of the important factors in limiting long-term hypobaric research studies with rodents is the difficulties inherent in the typical water supply bottles. The typical watering system for small animals utilizes a dispensing bottle that cannot be inverted without spillage of some water. Additional water loss occurs when the air expands inside the bottle as water warms to chamber temperatures or from temperature variations in the chamber itself. The reason is due to the bottle design where static pressure results in a surface tension at the nozzle holding the water inside. This external pressure is in delicate balance with the negative pressure of the air space at the top of the fluid. A small disturbance can disrupt this surface tension equilibrium resulting in water loss. This happens when the bottle is jarred, the animal breaks the surface tension when drinking, and/or the ambient barometric pressure changes to

a sufficient degree. The latter condition is magnified when water bottles are used for animal research studies conducted in the low pressure atmospheric conditions of high terrestrial elevations.

During decompression in hypobaric chambers, large amounts of water are lost when the air pocket at the top of the bottle expands (increased volume) inversely to the decreasing atmospheric pressure. Water loss also occurs due to minor oscillations in pressure control and could account for significant amounts when coupled with other disturbances such as animal feeding and nocturnal activities.

Exposed water on the chamber floor induces secondary health and environmental concerns and adds to the difficulties of conducting chronic altitude research studies. Daily returns to sea level in order to replenish drinking water and to clean the chamber became the only available solution, but added a complicating variable to the on-going research project.

#### MATERIALS AND METHODS

In view of the water bottle limitations as described above, the automatic water-drinking system represents a significant technological breakthrough. The water-dispensing system denotes the following achievements: water may be replenished on-line for indefinite operations, water is available to the rodent ad libitum independent of the pressure differential without leakage, the system is insensitive to water pressure and malfunctions due to mineral deposits, and the amount of water consumed can be measured while medications, drugs, and vitamins may be administered. Two lines connect the water reservoir to the hypobaric chamber. A water feedline from the storage reservoir and a reference line that equalizes the air pocket above the water. When the reservoir and chamber pressures are equal, the water supply to the animals is gravity induced.

The water supply reservoir may be a Travenol Intravenous Bottle (I.V.) or similar item suitable to withstand the pressure differential between the referenced chamber pressure and the ambient. The water supply is located externally to the hypobaric chamber so replacement units may be installed without interrupting an on-going study (Fig. 1). Toggle shut-off supply and vent (equalizing) valves isolate the bottle from the chamber facility during replacement. With an I.V. bottle, it is possible to estimate animal water consumption because it is graduated from 0-1000 ml, in increments of 50 ml. Water is gravity-fed at all times because a vent line provides equalization between the air space above the liquid and the chamber pressure. Poly-flo tubing (Imperial Eastman, Type 44P) is used because it is impervious to embrittlement or swelling, has excellent resistance to flexural fatigue, and can withstand a 200 psi burst pressure.

Bulkhead liquid/air tight connectors (Lapp, Model SL-7) provide uninterrupted feed-through for the poly-flo tubing (Fig. 2). A neoprene compression gland fits tightly around the tubing and effects a seal when the domed nut is threaded over the top of the tapered (collet) sleeve. The collet design accommodates various size tubing (.90 in - .265 in outside diameter).

An automatic pivoting stem drinking valve (Edstrom, Model PV1035T) dispenses fluid to the rodent on demand (Fig. 3). When the animal drinks, the stem pivots on one side allowing the flow of water. As soon as the stem is released, the diaphragm closes the valve, stopping the flow of water. The entire system is insensitive to pressure changes since the valve operates with a pressure differential as high as 60 psi or equally well as a gravity line. A Swagelock (Series QC) quick-connect fitting is used to connect the drinking valve to the animal cage inside the chamber. A automatic double-end shut-off

minimizes pressure loss and fluid spillage during the disconnect/connect operation. When disconnected, the stem assembly containing the water feeding valve remains with the cage while the body assembly attached to the hose separates with the cage to facilitate animal removal or cleaning.

#### DISCUSSION

→ The water dispensing system for rodents provides the potential for a no-loss infinite supply of water, permitting uninterrupted chronic research studies in hypobaric chambers. Other undesirable health and environmental problems caused by uncontrolled water losses have been eliminated. Uninterrupted long-term rodent research studies, cleaner cages and chamber interior, water consumption measurements, and the availability for the controlled administration of medications, drugs, and vitamins are the significant technological achievements of the water dispensing system.

The views, opinions, and/or findings contained in this report are those of the authors and should not be construed as an official Department of the Army position, policy, or decision, unless so designated by other official documentation. In conducting the research described in this report, the investigators adhered to the "Guide for the Care and Use of Laboratory Animals" as prepared by the Committee on Care and Use of Laboratory Animals of the Institute of Laboratory Animal Resources, National Research Council.

Citations of commercial organizations and trade names in this report do not constitute an official Department of the Army endorsement or approval of the products or services of these organizations.

#### REFERENCES

1. Baumel IP, Robinson SM, Platt WF: Multi-chamber system for toxicity studies in mice at simulated high altitude. *J. Pharm. Sci.* 56: 918-919, 1967.
2. Blatteis CM, Tucker EF: Construction of a low-cost, temperature-controlled altitude chamber. *J. Appl. Physiol.* 15: 1146-1148, 1960.
3. Bruback HF, Altland PD: Dual purpose pressure chamber with automatic safety device for animal studies. *J. Appl. Physiol.* 18: 1268-1269, 1963.
4. Malette WG, Fitzgerald JB, Elsmann B: Rapid decompression: A protective substance. USAF School of Aviation Medicine. Technical Report 60-62, 1960.
5. Valdivia E, McFee J: A chamber for continuous exposure to low barometric pressure. *J. Appl. Physiol.* 11: 491-492, 1957.
6. Devine JA, Cymerman A: An environmentally-controlled extended-use small animal hypobaric chamber. *Aviat. Space Environ. Med.* Accepted for publication, 1986.
7. Thomas Registers. Chambers, environmental, vacuum, space. 73d ed, Vol 1/92, One Penn Plaza, NY, 1983.

Figure 1. Composite view of the water dispensing system with magnified view of the disconnect fitting containing the water feed valve

Figure 2. Exploded view of the air-tight bulkhead connector used as a feed-through for the water supply tubing.

Figure 3. Exploded and cross sectional views of the pivoting stem drinking valve.

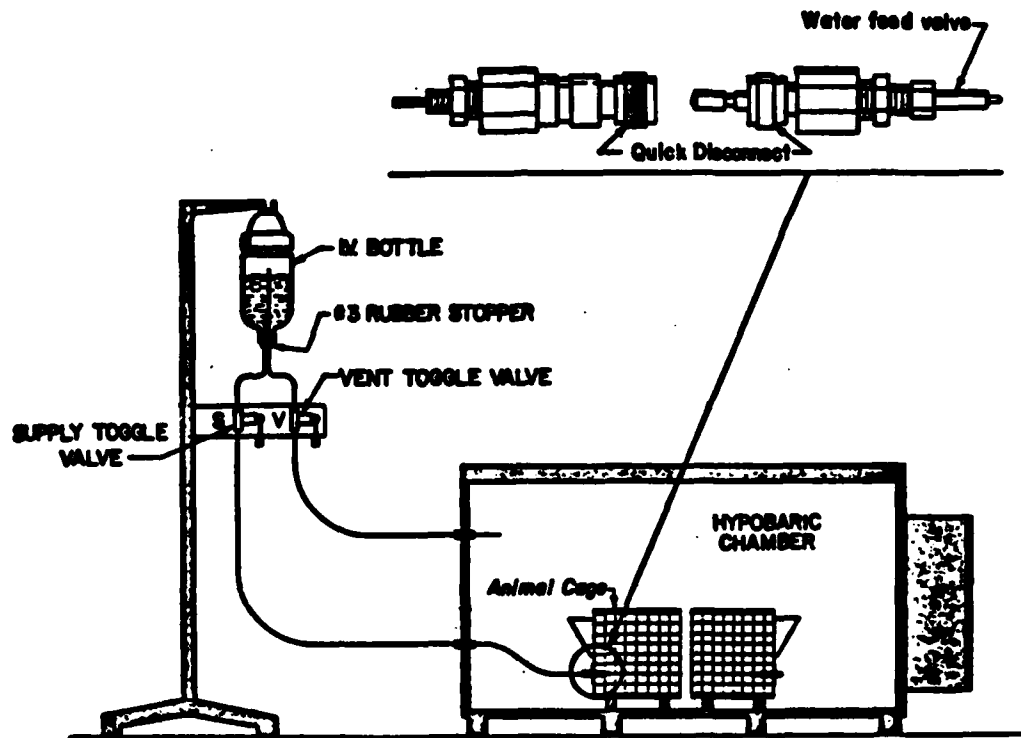

**WATER DISPENSING SYSTEM  
FOR RODENTS IN HYPOBARIC SIMULATOR**

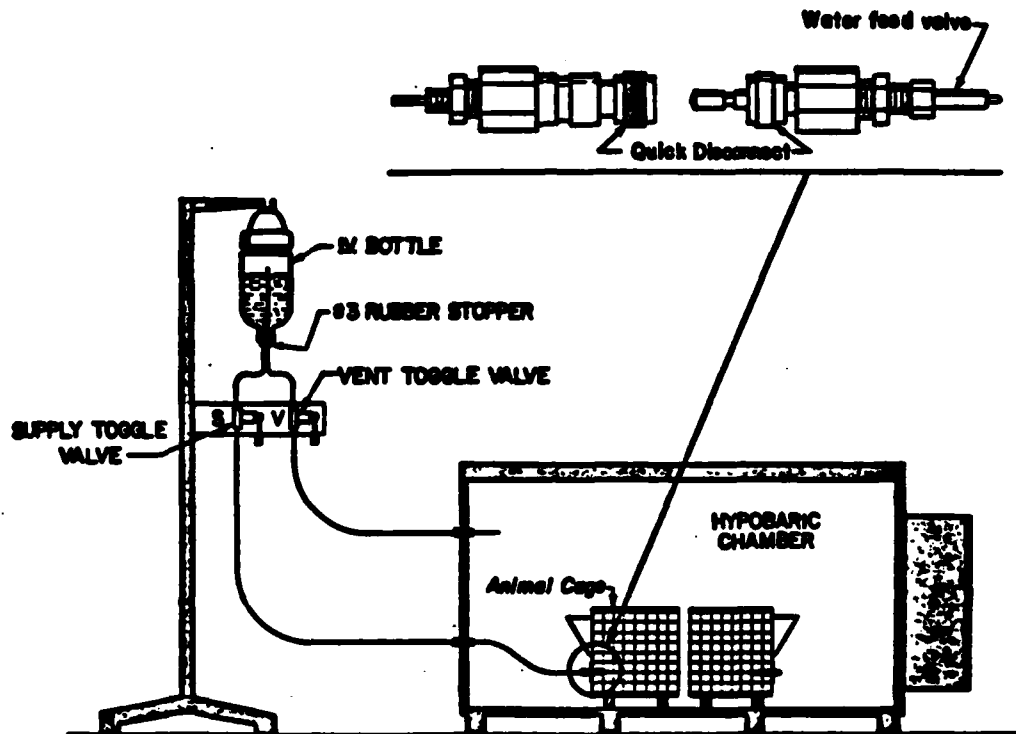

**WATER DISPENSING SYSTEM  
FOR RODENTS IN HYPOBARIC SIMULATOR**

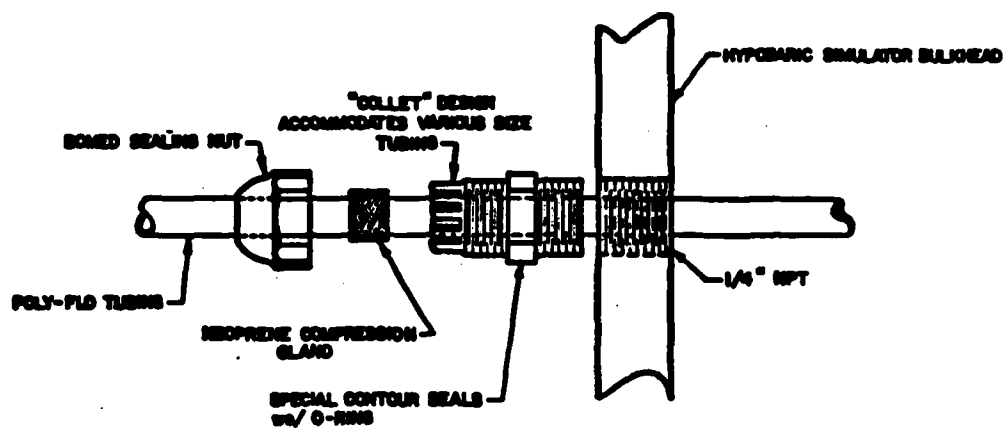

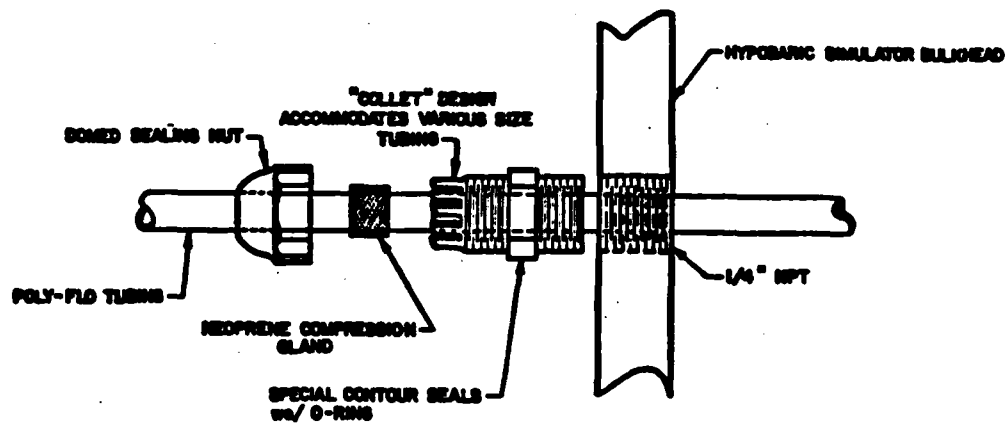

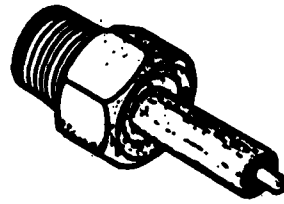

**PIVOTING STEM DRINKING VALVE**

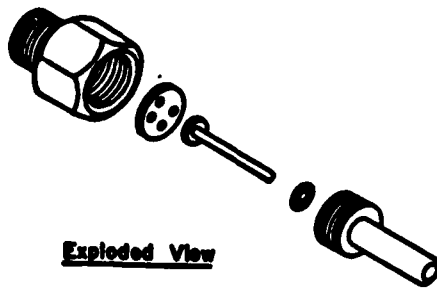

**Exploded View**

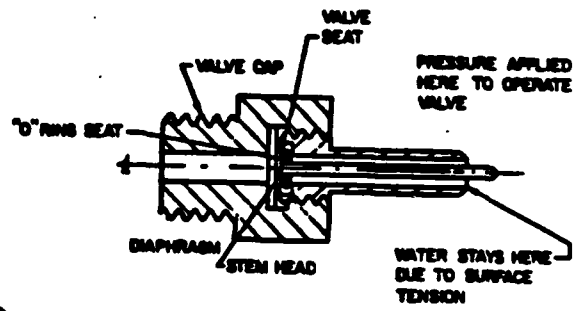

**Cross Section**

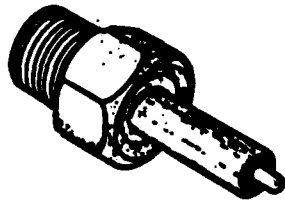

**PIVOTING STEM DRINKING VALVE**

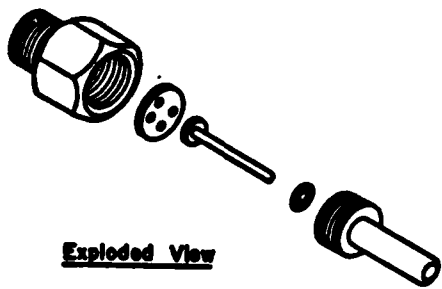

**Exploded View**

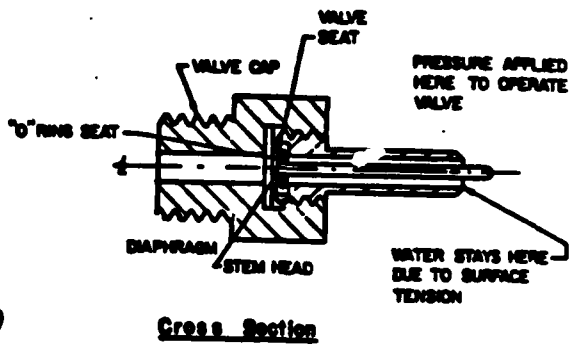

END

10-86

DTIC