

SECURITY CLASSIFICATION OF THIS PAGE (When Data Entered)

REPORT DOCUMENTATION PAGE

1a. REPORT SECURITY CLASSIFICATION UNCLASSIFIED		1b. RESTRICTIVE MARKINGS	
2a. SECURITY CLASSIFICATION AUTHORITY		3. DISTRIBUTION/AVAILABILITY OF REPORT A Statement	
2b. DECLASSIFICATION/DOWNGRADING SCHEDULE			
4. PERFORMING ORGANIZATION REPORT NUMBER(S) NWC TP 5923, Part 1		5. MONITORING ORGANIZATION REPORT NUMBER(S)	
6a. NAME OF PERFORMING ORGANIZATION Naval Weapons Center	6b. OFFICE SYMBOL (If Applicable)	7a. NAME OF MONITORING ORGANIZATION	
6c. ADDRESS (City, State, and ZIP Code) China Lake, CA 93555-6001		7b. ADDRESS (City, State, and ZIP Code)	
8a. NAME OF FUNDING/SPONSORING ORGANIZATION Naval Air Systems Command	8b. OFFICE SYMBOL (If Applicable)	9. PROCUREMENT INSTRUMENT IDENTIFICATION NUMBER	
8c. ADDRESS (City, State, and ZIP Code) Washington, D. C.		10. SOURCE OF FUNDING NUMBERS	
		PROGRAM ELEMENT NO.	PROJECT NO.
		TASK NO. A32-320G/008B/ WF31-330-000	WORK UNIT
11. TITLE (Include Security Classification) Diurnal Temperatures in Dump-Stored Missiles. Part 1. Comparison of Analytical Methods of Prediction With Experimental Data (U)			
12. PERSONAL AUTHOR(S) Ulrich, Richard D..			
13a. TYPE OF REPORT Final	13b. TIME COVERED From 1974 To 1984	14. DATE OF REPORT (Year, Month, Day) 1986, June	15. PAGE COUNT 64
16. SUPPLEMENTARY NOTATION			
17. COASTI CODES			18. SUBJECT TERMS (Continue on reverse side if necessary and identify by block number) Environmental criteria determination; Dump storage; Measurement techniques
FIELD	GROUP	SUB-GROUP	
20. ABSTRACT (Continue on reverse side if necessary and identify by block number) <p>(U) The values of analytical prediction of ordnance temperatures are compared with values of experimentally measured temperatures. Four simple analytical approaches for predicting specific temperature-time values were used, and the experimental values were obtained during 1974 at the Naval Weapons Center. This part, Part 1, covers analytical methods of prediction; Part 2 contains experimental data.</p>			
20. DISTRIBUTION/AVAILABILITY OF ABSTRACT <input checked="" type="checkbox"/> UNCLASSIFIED/UNLIMITED <input type="checkbox"/> SAME AS RPT. <input type="checkbox"/> DTIC USERS		21. ABSTRACT SECURITY CLASSIFICATION Unclassified	
22a. NAME OF RESPONSIBLE INDIVIDUAL C. Maples		22b. TELEPHONE (Include Area Code) 619-939-7252	22c. OFFICE SYMBOL 621

Diurnal Temperatures in Dump-Stored Missiles.

Part 1: Comparison of Analytical Methods of Prediction With Experimental Data

by

Richard D. Ulrich
Range Department

JUNE 1986

NAVAL WEAPONS CENTER
CHINA LAKE, CA 93555-6001



Naval Weapons Center

FOREWORD

The work reported herein covers one aspect of the dump-storage of ordnance; that is, comparison of the values from analytical prediction of ordnance temperatures with experimentally measured temperatures. This continuing effort has been sponsored by the Naval Air Systems Command under the Guided Missile Propulsion Technology Block Program (AirTask A32-320G/008B/WF31-330-000). Mr. Lee N. Gilbert is the NWC technology administrator for this program.

This work has had several contributors; these include: Howard C. Schafer, NWC, technical coordinator; Billy D. Martin, experimental technician; Frank Markarian, NWC, thermal analyst; T. E. Cooper, Naval Postgraduate School, thermal analyst; and Richard D. Ulrich, Brigham Young University, thermal analyst and report coordinator.

This report is being published in two parts; this part (Part 1) covers the analytical methods and results; Part 2 contains experimental data, along with diurnal data from various geographic locations. The report has been reviewed for technical accuracy by Crill Maples. It is released for information at the working level and does not necessarily reflect the views of NWC.

Approved by
R. V. BOYD, *Head*
Range Department
26 June 1986

Under authority of
K. A. DICKERSON
Capt., USN
Commander

Released for publication by
G. R. SCHIEFER
Technical Director

NWC Technical Publication 5923, Part 1

Published by	Technical Information Department
Collation	Cover, 33 leaves
First printing	335 copies

CONTENTS

Introduction	3
Background	3
Analytical Approaches	4
Cooper's Method	5
Markarian's Method	5
Ulrich's Methods	6
Field Temperature Measurements	7
Results and Discussion	16
Summary of Results	16
Detailed Comparisons	19
References	35
Appendixes	
A. Thermocouple Locations, 12 June 1974 Tests	37
B. Thermocouple Locations, 28 June 1974 Tests	43
C. Thermocouple Locations, 29 August 1974 Tests	49
D. Thermocouple Locations, 11 September 1974 Tests	55

INTRODUCTION

The work reported herein is related to temperature-time effects due to dump storage of ordnance items. Specifically, three simple, analytical approaches for predicting specific temperature-time values were compared with experimentally obtained diurnal data. The analysts were given the weather data (that is, air temperatures, humidity, wind speed and direction, and solar heat flux versus time of day) and the thermocouple locations and ordnance specifications. (Actually, the analysts had specified the locations at which they desired to predict the temperatures, and this dictated the thermocouple locations.) The analysts were to predict the temperatures as indicated by the thermocouples for the particular locations on the missile (or container) for the particular days chosen. These analytical results were compared with the experimental data after the predictions had been submitted. An essential part of this effort was the experimental determination of necessary temperature versus time of day, along with local weather data. This was done for a few specific days.

BACKGROUND

In the early 1970s, the question arose as to the ability of thermal analysts to predict the diurnal temperature distribution that would be attained by a dump-stored missile, either in or out of its shipping container. Three persons, fairly experienced in the thermal analysis techniques of the day, were given the following assignment:

1. Choose a specific missile (or missiles) available from the storehouse of those in use in the fleet.
2. Specify the location at which thermocouples should be attached in order to monitor the temperatures attained when the missile is stored in the outdoor environment (herein called "dump storage").
3. Specify the local meteorological data needed so that **you** can calculate the temperature response of the missile to the weather conditions.
4. After the instrumentation has been installed and the data taken for several days, pick a "nice" day, for which you will be given the weather data.
5. Calculate, using your best engineering ability and judgment, the temperature versus time for the 24-hour period you selected for the thermocouple locations you had selected.
6. Submit your predicted results before you see the test results.

This assignment was accepted by the analysts, who chose Shrike and Sidewinder missiles for their predictions.

During the summer of 1974, the field tests were conducted, as planned, at the Salt Wells facility of the Naval Weapons Center, which is located in the Mojave Desert of California. The thermocouples were mounted on the missiles and shipping containers at the specified locations and also at several additional locations. The specific locations of each thermocouple and the data channel numbers are shown in Appendixes A through D for the four configurations chosen for analysis. The additional thermocouples were mounted because this seemed a good opportunity to get much data for future reference and for applications not necessarily related to the needs of these analysts. Also, very little diurnal data had been published, and this seemed to be a good method of getting additional data at little or no cost. The belief was that the several extra thermocouples would have no influence on the output from the specified thermocouples. (The extra data are presented in Part 2 of this report, along with additional diurnal temperature data from a wide variety of geographic locations.)

In parallel with the experimental studies, the analytical approaches were being developed to the point at which the weather data were needed for the final predictions. (Since one analyst used two methods, four analytical approaches were, in fact, developed.) The purpose of these was to determine how close the temperature-time curves could be predicted for a few of the specific thermocouple locations by experienced heat-transfer analysts. The analysts were assumed to be typical of the heat-transfer specialists available in industry. A brief description of the analytical approaches is given in the next section of this report, followed by a description of the experimental data and then a discussion of the results.

ANALYTICAL APPROACHES

Predictions were conducted by Professor T. E. Cooper of the Naval Postgraduate School, Monterey, Calif. (analytical solution); Professor R. D. Ulrich of Brigham Young University and NWC (analytical and thermal standard solutions), and C. F. Markarian of the NWC Aerothermodynamics Branch (computer solution).

With all four techniques, a number of simplifying assumptions were made, including one-dimensional heat transfer (radial direction only) or lumped capacitor models (no internal temperature gradients). Although highly detailed, two- or three-dimensional computer models could have been generated, the usefulness of these models was limited by inadequate knowledge of the input conditions, and it was felt that the additional sophistication of the internal models was not justified. More to the point, it seemed superfluous to calculate temperature numbers to 16 significant digits when several of the inputs were approximated to within 20 to 30%. The objective of this effort was to demonstrate the use of relatively simple techniques to predict open storage thermal response for preliminary design purposes. The test data were, however, of a detailed enough nature to allow verification of complex thermal models.

The goal in this report is not to present details of the predictive analytical models of Cooper, Markarian, and Ulrich, but mainly to compare the analytical results with

experimental results. Hence, only a summary of the analytical methods is presented, along with their individual results. A brief discussion follows the comparison. Since the thermal standard method required experimental results from the thermal standard device, which had been placed in the dump-storage area with the missiles, these predictions were not made until after the purely analytical results from Ulrich had been submitted.

COOPER'S METHOD

The method used by Cooper was to write a "complete" energy balance equation for an object stored outdoors. The equation included solar radiation, long wavelength radiation exchange with the sky, radiation exchange with the ground, convection heat transfer to and from the air, and energy storage in the missile (and/or container). The following equation resulted:

$$\begin{array}{cccccc}
 mc_p \frac{dT}{dt} & + & hA(T - T_\infty) & + & h_s A(T - T_s) & + & h_g A(T - T_g) & = & G^* \\
 \text{capacitance} & & \text{convection} & & \text{linearized sky} & & \text{linearized ground} & & \text{solar} \\
 \text{term} & & \text{term} & & \text{radiation} & & \text{radiation} & & \text{radiation} \\
 & & & & \text{term} & & \text{term} & & \text{term}
 \end{array}$$

where Brunt's equation is used to predict T_s .

The ambient air temperature was fit to a sine curve and was inserted for T_∞ . Another sine curve was fit to the solar radiation data. Since the ground temperature was not known, but was assumed to be close to the missile temperature, this term was assumed to be negligible and was dropped from the solution. All the mass was assumed to have one temperature (this is called the lumped-capacitance method). This implies that there is no radial gradient of temperature in the missile. Brunt's equation was used for the effective sky temperature (Reference 1). Brunt's equation gives sky temperature as a function of air temperature and specific humidity. This effect was then linearized into an "effective convection" heat loss. The convection heat transfer coefficient was obtained from the average wind velocity for the day (blowing normal to a horizontal cylinder) and was used as a constant for the day. All of these assumptions, then, produce a sinusoidal temperature-versus-time distribution for the missile. The sine curve has a 24-hour period.

For the missile-in-container calculations, the same basic energy balance equation was used as before to determine the container temperature, and this temperature was used as a forcing function on the stored missile.

MARKARIAN'S METHOD

The thermal forcing functions used by Markarian were solar radiation (input on an hourly basis as given from the pyrheliometer), atmospheric radiation using Brunt's equation,

$$q_{atm} = \sigma T_{air}^4 (0.5 + 0.06e^{0.5})$$

and convection to and from the ambient air, with the cross flow and parallel flow convection coefficients being averaged. These forcing functions lead to the simplified equation for equilibrium temperature:

$$\alpha_s q_{solar} + \alpha_1 q_{atm} + h(T_{air} - T_{skin}) = \alpha \epsilon T_{skin}^4$$

Markarian's previous experience with environmental effects had shown that equilibrium temperature gave a good approximation to the maximum temperature on the top of ordnance in dump storage when used in conjunction with solar radiation data as measured by a pyrheliometer. This equation shows the sensitivity of T_{skin} to solar absorptivity, emissivity (note that $\alpha_1 = \text{emissivity}$), and the heat transfer coefficient.

For the Shrike missile out of container (12 June 1974) and in a single-store container (28 June 1974), Markarian used a one-dimensional (radial) computer model. Because of their low thermal mass, the lightweight sections (guidance and control) were modeled as a single lump. The sand-filled motor and warhead sections were modeled using 25 radial nodes. For computations of the missile in a container, the container was treated as a single node. Both radiation and convection were used to evaluate heat transfer between the container and the missile.

An energy balance equating the energy "in" minus the energy "out" to the stored energy was set for each node, and the system of equations was solved using the SINDA thermal analyzer program. Input included solar absorptivity, emissivity, thermal properties of the materials, the hourly arrays of solar energy, atmospheric radiation, ambient air temperature, humidity, and wind speed. These all gave an output listing of the hourly temperature for each node. Of specific interest were the nodes containing thermocouples.

ULRICH'S METHODS

Ulrich presented results of two different methods: first, a purely analytical solution and, later, a method based on results obtained with the thermal standard.

Analytical Method

In the analytical approach, only the temperature of the outside skin of the missile, or container, was calculated as a function of time of day. Based on some previously published results for objects the size of Shrike or Sidewinder missiles (Reference 2), the effective thickness was shown to be about 10 to 15% of the radius of cylindrical missiles. Thus, a one-lump, transient method that included this effectiveness thickness was used to estimate the top surface temperature of the missile or container. An energy balance was applied to the effective mass, and the temperatures were calculated. The temperatures for other than the missile top position were estimated by modifying the solar energy data using the cosine law and adjusting solar radiation on the particular east side or west side location for time of day.

The long-wavelength sky radiation was estimated by using the air temperature minus 20°F. This number (20°F) had been gained from experience. It is an effective temperature for the sky--higher than predicted by Brunt's equation for a clear sky by about 30 to 50°F. (Since

the time of these calculations, another sky radiation equation has been published by Idso and Jackson (Reference 3), wherein the sky temperature for the Salt Wells location during a clear summer night would be 15 to 20°F below the ambient air temperature.)

The assumption was made that the ground temperature was the same as the missile temperature; thus, no heat was exchanged between these two bodies. The energy equations were written and programmed for an HP 9830A computer in Basic language. This method uses an effective mass that is between Cooper's single lump using all the mass and Markarian's method wherein 25 lumps are used. The significant differences among these methods in calculated temperature results were not in the number or size of nodes used, but in the surface radiation properties used and the method in which they were handled.

Thermal Standard Method

The second method used by Ulrich was based on a previously published technique using data from a device called the NWC thermal standard (References 4 and 5) (see also Part 2 of this report). The thermal standard is a thin-walled, stainless steel, 6-inch-diameter sphere filled with room-temperature-vulcanizing (RTV) rubber. The original purpose of the NWC thermal standard was to use a relatively passive-looking device, instrumented for temperature monitoring, for data collection purposes. This device could be placed in any area of the world and would produce temperature responses similar to the responses from ordnance items had they been stored at the same location. This device interacts with all the thermal forcing functions and integrates them into an output temperature-versus-time recording. The surface temperature of any particular thermocouple location was shown, in Reference 5, to be predicted very well by the equation

$$T_{item} - T_{air} = \left(\frac{\alpha_{item}}{\alpha_{TS}} \right) (T_{TS} - T_{air})$$

where TS is thermal standard.

Since thermal standard data were being collected continuously at the Salt Wells dump storage simulation location,, it seemed logical to try to use this method to predict the specific temperatures of the missiles and compare these results with the results from the purely analytical methods. The method does not require a knowledge of the weather data, but it does require the thermal standard response temperatures to those elements for the particular day being considered.

FIELD TEMPERATURE MEASUREMENTS

Temperature measurements for comparison with predictions were obtained on an AGM-45A-3 Shrike missile and an AIM-9H-2 Sidewinder missile. Both missiles had operational guidance and control sections but inert warheads and rocket motors. A fresh coat of standard paint was applied to each missile before the series of tests was started. Desert sand was used to simulate rocket motors, and a cast plastic was used to simulate warhead

explosive, which was used in the Sidewinder. Both missiles were extensively instrumented with copper-constantan thermocouples. Details on the locations are given in Appendixes A-D. The missiles were tested in an all-up configuration, although wings and fins were not installed on the Shrike.

Tests were performed with the missiles both in and out of the shipping containers. The same two missiles were used for all the tests, both in and out of containers, the tests being at different times of the summer. The Shrike containers consisted of a Mk 399 Mod 0, light navy gray, steel, single-store container and a three-missile container with a white acrylic top and gray aluminum bottom. The Sidewinder container was white acrylic and accommodated four missiles. During the tests with multistore containers, additional dummy stores were used to fill the container. The containers were also instrumented with thermocouples, as shown in the appendixes.

In addition to the ordnance temperatures, various environmental conditions were monitored for use in the predictions. Ambient air temperature was measured in a Stevenson shelter located about 100 feet from the missiles (Channel 9 on the data logger); wind speed and direction were measured at the test site and at the missile level; solar radiation as measured by a pyrheliometer was obtained from the Range Instrumentation Support Division; and relative humidity was monitored at the test site. The area was desert sand on the surface, and no special changes were made by way of surface conditioning or preparation.

Figures 1 through 6 are photographs of the experimental area, instrumentation, and ordnance tested.

Data were measured continuously throughout the summer of 1974 from early June to the middle of September. Also, the thermal standard data (five thermocouples: top, east side, west side, bottom, and center of the sphere) were monitored during the entire time. All the data were recorded on Honeywell Model 16 recorders.

The dates selected for analysis and the corresponding test configurations are listed in Table 1. These dates were chosen because these were cloudless days with relatively low winds and were deemed to be easier for analysis than other days. Also, the days chosen were similar to the two or three preceding days and at least one following day. This ensured that no weather front passed by and caused a 1-day "glitch" in the long-term data. (The computer predictions described herein were performed with the 12 June, 28 June, 29 August and 11 September data.) The recorded environmental conditions for these dates are listed in Table 2.

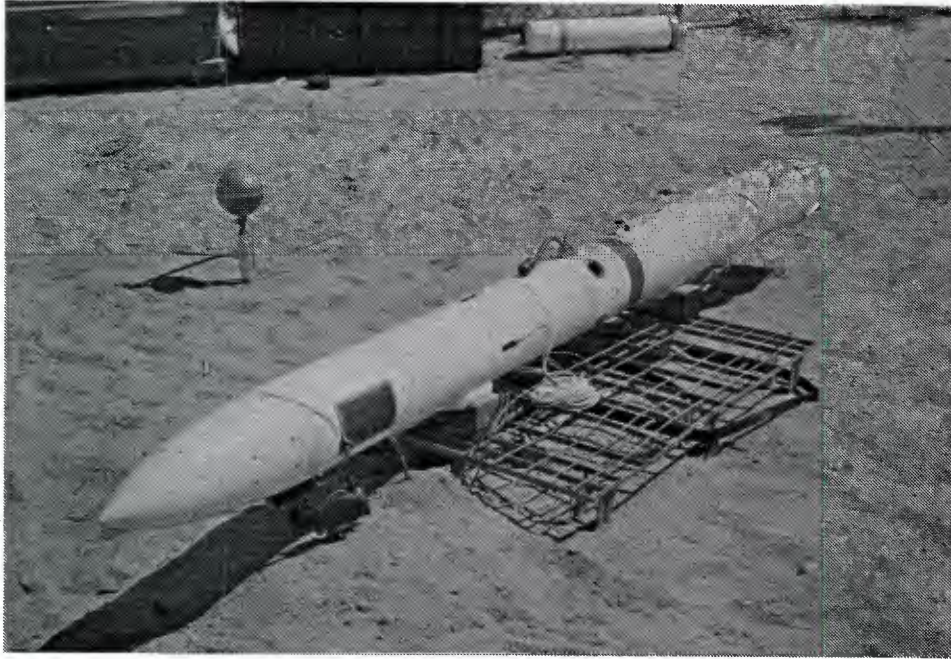

FIGURE 1. Shrike Missile With 18-Inch-High Thermal Standard.



FIGURE 2. All-Up Shrike in Single-Store Container.

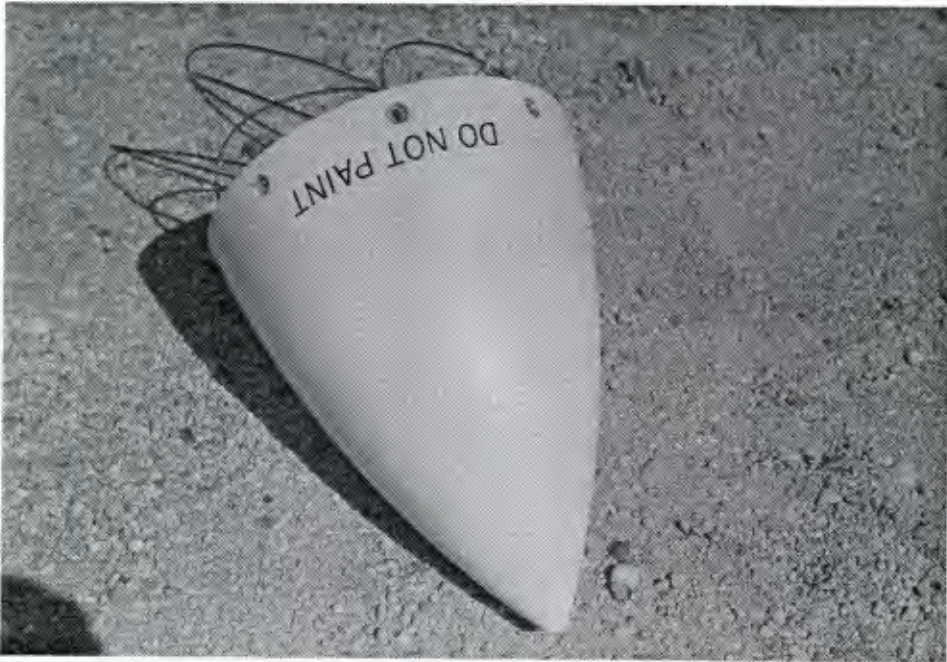

FIGURE 3. Shrike Radome.

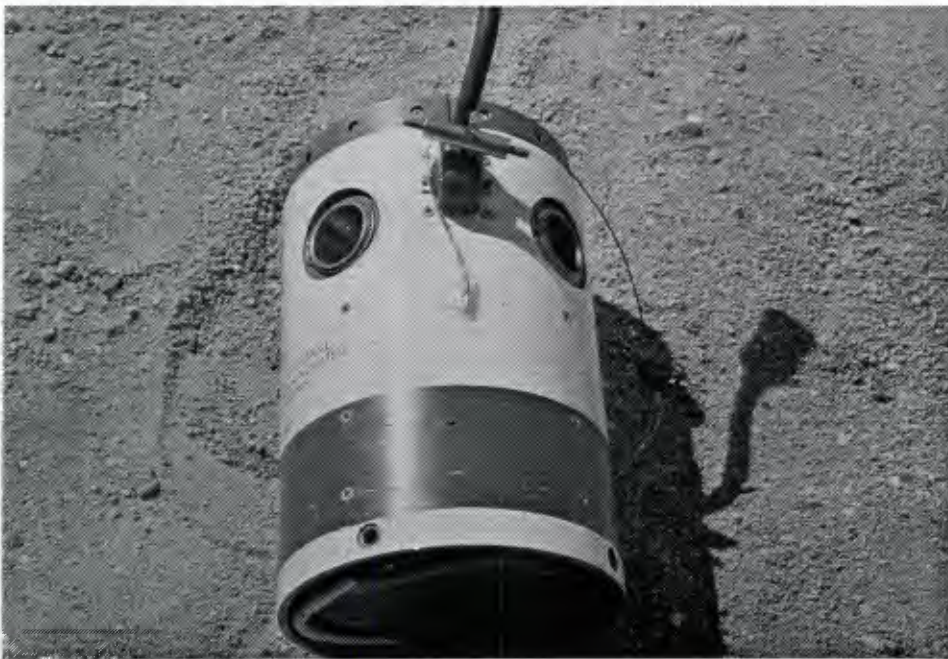

FIGURE 4. Shrike Guidance Section.

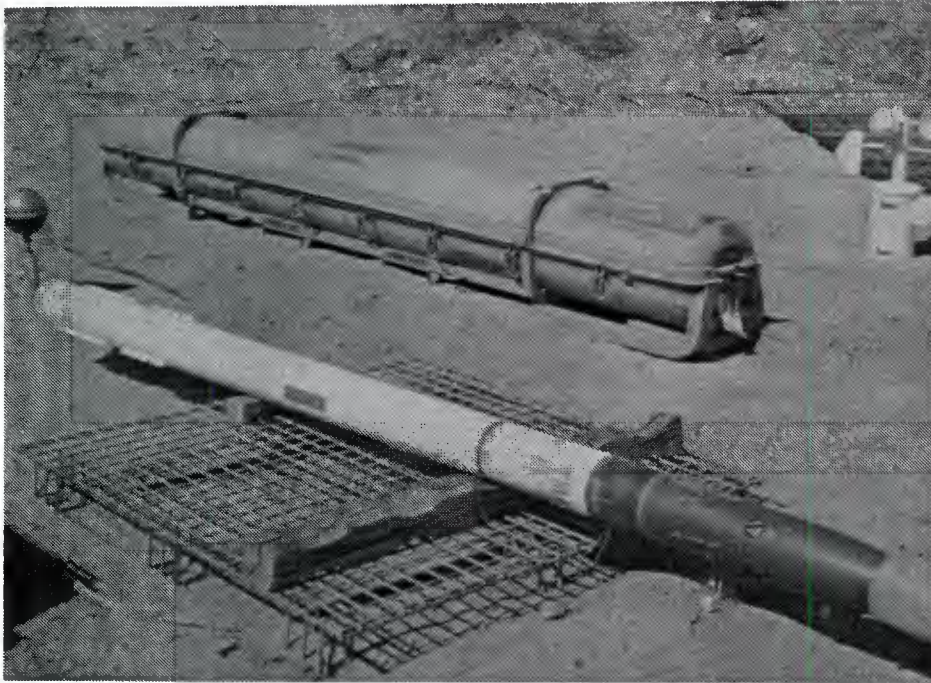
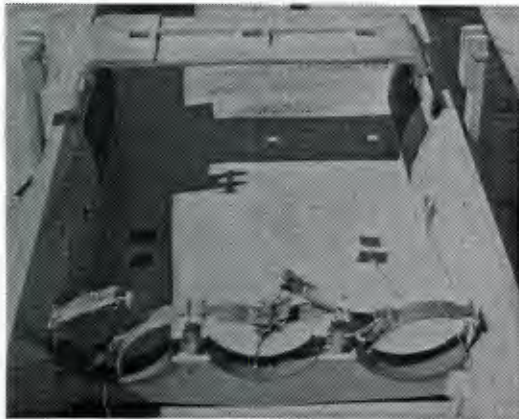

FIGURE 5. Sidewinder Out of Container and Shrike in Single-Store Container.



a. Bottom (Aluminum).



b. Top (Acrylic).

FIGURE 6. Multistore Container.

TABLE 1. Test Dates Selected for Analysis

Date	Test configuration
12 June 1974	Shrike out of container
28 June 1974	Shrike in single-store container
29 August 1974	Sidewinder out of container
11 September 1974	Shrike and Sidewinder in containers

**TABLE 2. Weather Data for the Four Dates Used in the Analyses.
a. 12 June 1974.**

Time	Wind, mph	Wind direction	Relative humidity, %	Air temperature, °F	Solar radiation, langleys
0000	1	variable	28	81	---
0100	2	variable	28	81	---
0200	2	variable	28	74	---
0300	1	variable	30	71	---
0400	1	variable	34	67	---
0500	1	variable	38	67	---
0600	1	variable	44	65	0.6
0700	1	variable	42	72	7.4
0800	2	variable	34	80	22.0
0900	2	variable	30	86	37.2
1000	3	variable	26	94	51.0
1100	3	variable	22	100	63.2
1200	3	variable	20	104	72.0
1300	4	variable	15	106	79.0
1400	4	variable	14	110	78.2
1500	5	variable	14	108	70.8
1600	4	variable	12	110	62.6
1700	3	variable	12	109	49.8
1800	5	variable	12	105	35.4
1900	5	SW	14	100	19.8
2000	4	SW	17	95	7.2
2100	4	SW	20	90	0.4
2200	4	SW	20	86	---
2300	4	SW	25	83	---

TABLE 2. (Contd.)
b. 28 June 1974.

Time	Wind, mph	Wind direction	Relative humidity, %	Air temperature, °F	Solar radiation, langley
0000	2	SW	20	80	---
0100	1	SW	20	77	---
0200	2	variable	21	75	---
0300	1	SW	22	70	---
0400	1	SW	26	67	---
0500	1	SW	33	59	---
0600	1	SW	40	58	0.4
0700	1	SW	34	66	8.2
0800	2	SW	30	70	22.2
0900	2	variable	26	80	37.8
1000	2	variable	22	84	52.2
1100	3	variable	19	90	63.4
1200	3	variable	15	96	72.6
1300	4	variable	14	101	78.8
1400	3	variable	13	108	78.8
1500	4	variable	12	107	72.6
1600	3	variable	11	104	63.6
1700	4	variable	10	102	51.6
1800	3	SW	10	98	37.2
1900	2	variable	11	94	21.2
2000	2	variable	13	90	7.2
2100	3	variable	14	86	0.4
2200	3	SW	20	84	---
2300	3	SW	22	83	---

TABLE 2. (Contd.)
c. 29 August 1974.

Time	Wind, mph	Wind direction	Relative humidity, %	Temperature, °F	Solar radiation, langley
0000	3	S	26	78	---
0100	2	S	26	77	---
0200	1	S	27	74	---
0300	1	S	28	72	---
0400	1	SW	30	70	---
0500	0	SW	32	69	---
0600	1	SW	33	65	---
0700	0	SW	37	66	0.8
0800	1	NW	35	72	9.0
0900	2	NW	32	78	26.0
1000	1	variable	29	82	41.4
1100	2	variable	26	88	54.8
1200	2	variable	22	94	65.6
1300	3	variable	18	97	70.6
1400	3	variable	17	100	70.6
1500	3	variable	12	100	65.4
1600	4	SW	11	100	56.0
1700	2	SW	10	98	43.8
1800	2	SW	10	96	28.8
1900	2	SW	10	86	12.6
2000	3	S	13	80	1.0
2100	1	SW	15	76	---
2200	1	SW	20	76	---
2300	1	variable	24	70	---

NWC TP 5923, Part 1

**TABLE 2. (Contd.)
d. 11 September 1974.**

Time	Wind, mph	Wind direction	Relative humidity, %	Temperature, °F	Solar radiation, langleys
0000	3	SW	21	78	---
0100	3	SW	24	75	---
0200	3	SW	24	75	---
0300	2	variable	24	74	---
0400	2	variable	28	68	---
0500	2	E	30	64	---
0600	1	variable	32	63	---
0700	0	variable	32	64	0.2
0800	0	SW	30	70	7.8
0900	1	variable	29	79	21.8
1000	1	variable	25	85	37.2
1100	2	variable	22	92	51.0
1200	2	variable	20	95	61.2
1300	3	variable	19	97	65.8
1400	3	variable	18	100	65.4
1500	4	variable	16	102	60.4
1600	4	variable	16	102	50.4
1700	7	S	16	98	38.4
1800	4	SW	18	94	22.6
1900	4	SW	21	87	8.4
2000	4	SW	24	82	0.2
2100	4	SW	26	82	---
2200	3	SW	26	80	---
2300	2	SW	28	79	---

Notes: Solar radiation is logged by weather facility using standard time.
All times are daylight.
The correction for solar radiation time has been made.

RESULTS AND DISCUSSION

The comparative results are portrayed in two ways. First, because they take less space, tables of maximum temperatures and the times (on a 24-hour clock) at which they occurred are presented, and the results of the various methods are compared with the experimental temperatures. Second, for the cases in which the analysts calculated temperature versus time of day, the results are given in graph form.

SUMMARY OF RESULTS

Table 3 gives the results for the all-up Shrike (freshly painted with an "epoxy white" paint.) Table 3 also gives the times at which the maximum and minimum temperatures were observed. Markarian's predictions were low by 13 and 10°F, probably owing to his use of Brunt's equation, which gives much lower effective sky temperatures than observed by the author in the desert environment. This would explain why both the maximum and minimum temperature predictions were low. Of course, the predictions were sensitive to surface absorptivity. However, an error in absorptivity of solar energy would affect only daytime temperature calculations and not the minimum predicted temperatures. Cooper's values were closer, but again low, probably because of the much larger effective mass used for the missile, which dampens out extreme variations. This was further verified by the calculated time at which the maximum was predicted--4 hours after it occurred, as indicated by the experimental data. The dampening effect and the time lag are directly connected in lumped-capacity systems. Ulrich's predictions were good for the top and bottom, where the solar energy could be handled easily, but not for the east and west sides. Apparently the cosine of the time-of-day function was not a good way to modify the solar data, which were collected on a horizontal instrument. The thermal standard method did very well. A significant point to remember is that the thermal standard had a bare metal surface, which has a very low emissivity in the long-wavelength range. This would account for the relatively large overprediction of nighttime temperatures.

Values for the Shrike in a single-store container are given in Table 4; for the all-up Sidewinder, in Table 5, and for the Shrike and Sidewinder in a multistore container, in Table 6.

Based on these tables, one would think that reasonable differences between analytical predictions and experimental data are 5 to 15°F when the values are for maximum temperatures in the desert climate and the missile is painted white. This is true when the peak temperatures are measured to be 25 to 30°F above the ambient air temperature. One would expect larger differences for darker paint and smaller differences for other climates. However, the expected error for either darker painted surfaces or a more moderate climate would be a smaller percentage of the difference between the peak missile temperature and the ambient air temperature, even when its magnitude is a number larger than 15°F.

Differences of 5°F or less probably have no significance. That is, on a given day, 5°F is as close as experienced experimentalists can **measure** the same thing. In Part 2 of this report, the detailed test results are presented wherein two "identical" thermal standards were monitored in the same dump-storage site. Comparison of the results from these two nearly

TABLE 3.
Comparison of Maximum and Minimum Temperatures (in °F), 12 June,
All-up Shrike. (Times shown in parentheses.)

Position	Experimental	Cooper	Markarian	Ulrich	Thermal standard
Top:					
max.	123 (1300)	115 (1700)	110 (1500)	122 (1400)	125 (1300)
min.	61 (0500)	57 (0600)	51 (0600)	60 (0600)	68 (0600)
Bottom:					
max.	122 (1600)			116 (1700)	117 (1600)
min.	71 (0500)			72 (0600)	71 (0500)
East:					
max.	116 (1300)			107 (1200)	116 (1600)
min.	65 (0500)			65 (0500)	69 (0500)
West:					
max.	130 (1600)			118 (1600)	126 (1600)
min.	66 (0500)			64 (0600)	67 (0600)

TABLE 4.
Comparison of Maximum and Minimum Temperatures (in °F),
28 June, Shrike in Container. (Times shown in parentheses.)

Position	Experimental	Cooper	Markarian	Thermal standard
Top:				
max.	161 (1400)	125 (1500)	148 (1400)	156 (1400)
min.	54 (0500)	54 (0300)	38 (0600)	61 (0500)
Bottom:				
max.	123 (1800)			127 (1400)
min.	65 (0500)			62 (0500)
East:				
max.	150 (1100)			133 (1100)
min.	56 (0500)			62 (0500)
West:				
max.	157 (1400)			151 (1500)
min.	56 (0500)			62 (0500)

TABLE 5.
Comparison of Maximum and Minimum Temperatures (in °F),
29 August, All-up Sidewinder. (Times shown in parentheses.)

Position	Experimental	Cooper	Thermal standard
Top:			
max.	107 (1500)	104 (1600)	111 (1400)
min.	56 (0600)	58 (0700)	59 (0600)
Bottom:			
max.	108 (1500)		105 (1400)
min.	62 (0700)		60 (0600)
East:			
max.	105 (1500)		104 (1300)
min.	60 (0600)		59 (0600)
West:			
max.	110 (1600)		111 (1500)
min.	59 (0700)		58 (0600)

TABLE 6.
Comparison of Maximum and Minimum
Temperatures (in °F), 11 September, Multistore
Container. (Times shown in parentheses.)

Position	Experimental	Thermal standard
Top:		
max.	102 (1500)	111 (1500)
min.	61 (0700)	66 (0700)
Bottom:		
max.	107 (1600)	109 (1500)
min.	69 (0700)	66 (0700)
East:		
max.	no data	
min.	no data	
West:		
max.	110 (1600)	118 (1500)
min.	63 (0700)	67 (0700)

identical objects placed side by side in the outdoor environment reveals that the temperatures varied by a few degrees. In just these 24 days shown, the maximum temperatures differed by as much as 14°F. These, and other similar results, lead to the statement, "when objects are stored in outdoor situations, measured temperature differences of 5 or 6 degrees are not significant." This is true when an effort is being made to get the same results. When other uncontrolled variables are considered (such as paint aging, surface scratches, random directions relative to north, oxidation, thermocouple attachment method, cloud cover, dust, local wind effects, etc.), it seems that one would be unsure of his ability to predict the temperature difference between an object and the ambient air to within 15 or 20°F. Some of the significant unknowns include effective sky temperature, absorptivity to solar radiation wavelengths, emissivity, heat transfer coefficient, and reflectivity for nonhorizontal surfaces. Also, the presence of thermal instrumentation affects the very thing being measured. These plus random, or unexplainable, measurement errors have led to this $\pm 10^\circ\text{F}$ error statement.

Each of the cases presented in Tables 3-6 is shown graphically in the temperature-versus-time of day comparison curves described below for several locations on the missiles and containers. Typical of these data are temperatures slightly lower than air temperature late at night for the top surfaces. This is due to the radiation to the night sky, which is cooler than the ambient air. The maximum temperatures are 20 to 25°F above the air temperature in the early afternoon for white painted stores and 40 to 50°F above air temperature for the gray painted containers.

DETAILED COMPARISONS

Figure 7 is a comparison of the predictions by Cooper, Markarian, and Ulrich (both analytical and thermal standard methods) with the Shrike motor top data for 12 June 1974. The results show that:

1. The thermal standard method prediction was 2 to 5 degrees high.
2. Cooper's prediction was generally low by 10 to 15 degrees and lagged by about 4 hours.
3. Markarian's prediction was low by 15 to 20 degrees and lagged by about 2 hours.
4. Ulrich's predictions (analytical) were about 2 to 15 degrees low over the 24-hour period.

The 15-degree low for Ulrich's prediction seems to be more of an error in time of sunrise than in calculation of temperature. In the thermal standard method the absorptivity was 0.29 for the white paint and 0.6 for the 304 stainless steel.

Figure 8 is a comparison of the predictions by the thermal standard and by Ulrich (analytical) with data for the same motor, but at the bottom location. The results were all within 2 to 4 degrees at the extreme temperatures. However, in the early morning hours, the analytical method was lagging again by about 2 hours. These results again show the positive value of using the thermal standard.

Figures 9 and 10 show similar results for the east and west sides of the Shrike. Again, Ulrich's analytical method and the thermal standard were used. These results again show the effect of the cosine function on the modification of the solar data as being inadequate.

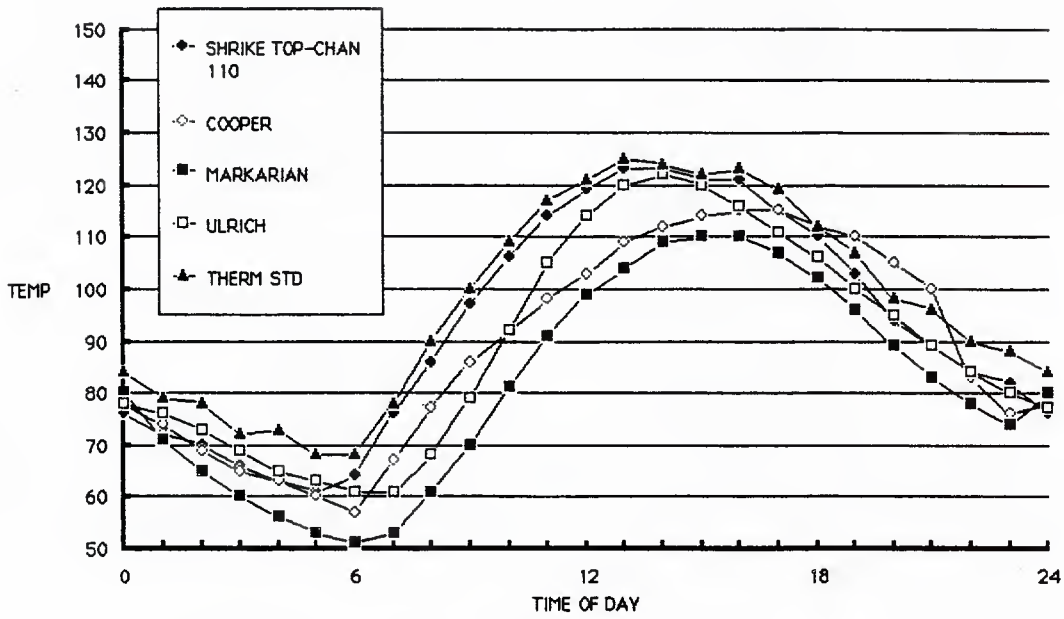

FIGURE 7. Shrike Motor Top, 12 June 1974 Experimental Data.

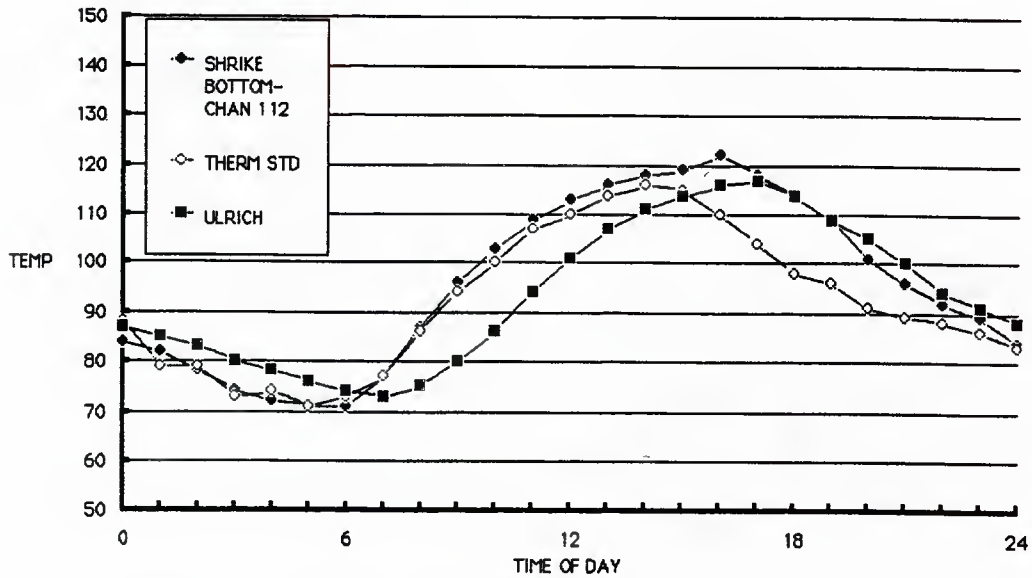

FIGURE 8. Shrike Motor Bottom, 12 June 1974 Experimental Data.

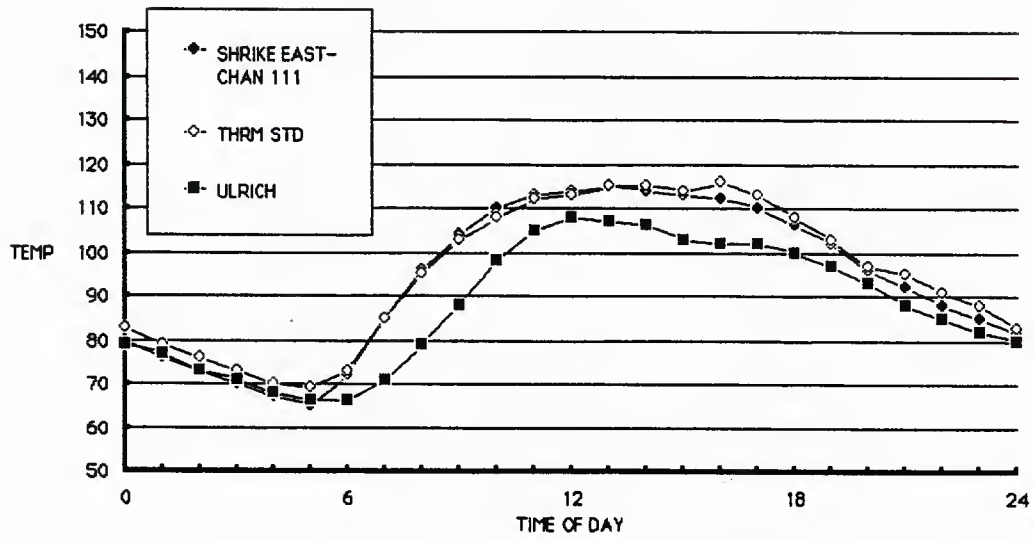

FIGURE 9. Shrike Motor East Side, 12 June 1974 Experimental Data.

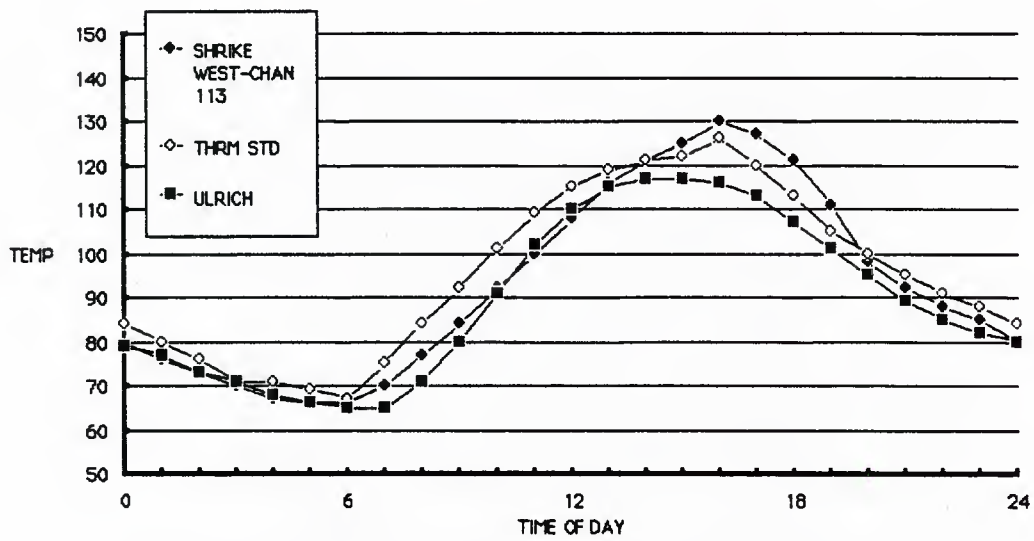

FIGURE 10. Shrike Motor West Side, 12 June 1974 Experimental Data.

Data on the Shrike container top for 28 June 1974 were compared with predictions by all four techniques; the results are presented in Figure 11. The results are qualitatively the same as those for the all-up Shrike, but the magnitude of the prediction errors is greater because the difference between the container and the ambient air is much greater. Since there was very small thermal mass, the lag, or time effect, was not as much in error. However, since Cooper's method put all of the mass in a single lump, the error in predicting the maximum temperature was 35°F.

Figures 12, 13, and 14 show the results by Ulrich and the thermal standard for the west side, east side, and bottom locations, respectively, for the Shrike container. For the east side case, the thermal standard method did not do a good job of prediction; no reason is given for this result.

For the 29 August 1974 Sidewinder motor top, calculations by Cooper and by the thermal standard method were compared with experiment (Figure 15). The results for both were within 6 to 8 degrees. Again, Cooper's method showed a lag of 2 to 3 hours. These were closer than the previous comparisons; however, the difference between missile temperature and ambient air temperature was only 7 degrees.

Figures 16, 17, and 18 show the comparison of predictions by the thermal standard with experimental data for the Sidewinder motor bottom, east, and west sides, respectively. The results compared very well--to within about 4 degrees in all these cases.

Figures 19, 20, and 21 show similar results on the Shrike container for 11 September 1974. In this case, the comparisons were not quite as close as before for the thermal standard method. The reason suggested for the less accurate prediction ability of the thermal standard in this case is the semitransparent nature of the white acrylic container top. The thermal standard method overpredicted the top and west side peak temperatures by about 10 degrees in both cases.

Figures 22 and 23 show the comparison between the Ulrich and thermal standard predictions and the Shrike control section (top outside skin) and Shrike computer control section (center), respectively, for the 6 June 1974 experimental data. Figure 22 shows very close agreement after sunup. The high prediction of the thermal standard before sunrise tends to show the effect of the bare metal emissivity on long wavelength radiation as compared to solar wavelengths. Ulrich's analytical method was uniformly low while the sun was up. Also, the lag indicates that his assumed time of sunrise was 1 or 2 hours too late. Figure 23 shows very good agreement between the thermal standard prediction and the experimental values.

For the 6 June 1974 Shrike motor center, calculations by Markarian and by the thermal standard method were compared with experiment (Figure 24). They are not in very close agreement. The thermal standard method leads the experimental data by about 2 hours, and Markarian's analytical method lags by about 5 to 7 hours. Apparently, the thermal standard was less massive than the Shrike, and Markarian allowed much more mass in his analysis than actually existed.

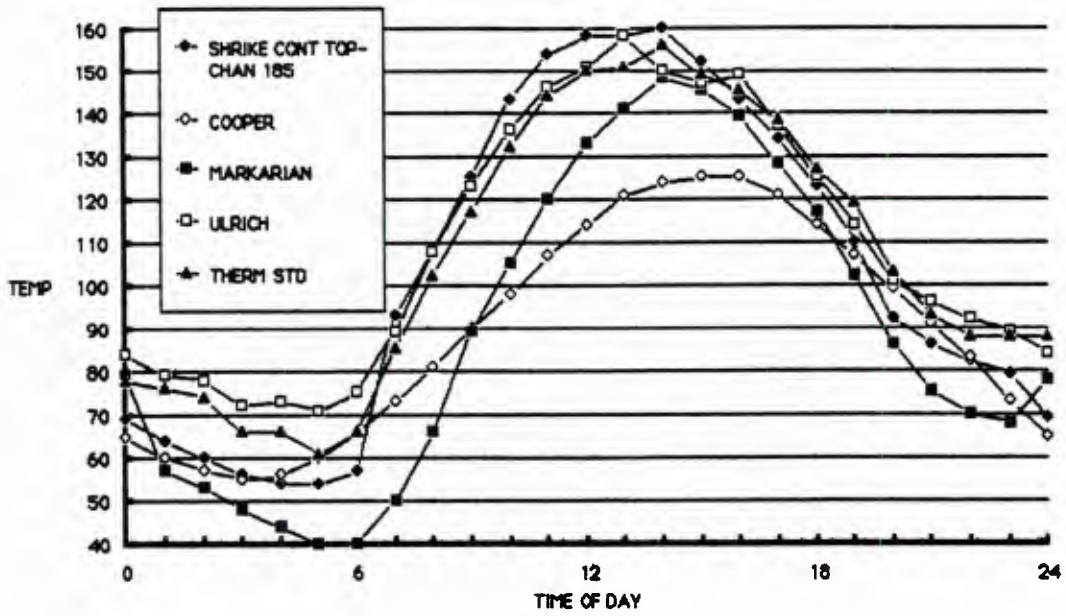

FIGURE 11. Shrike Container, Top, 28 June 1974 Experimental Data.

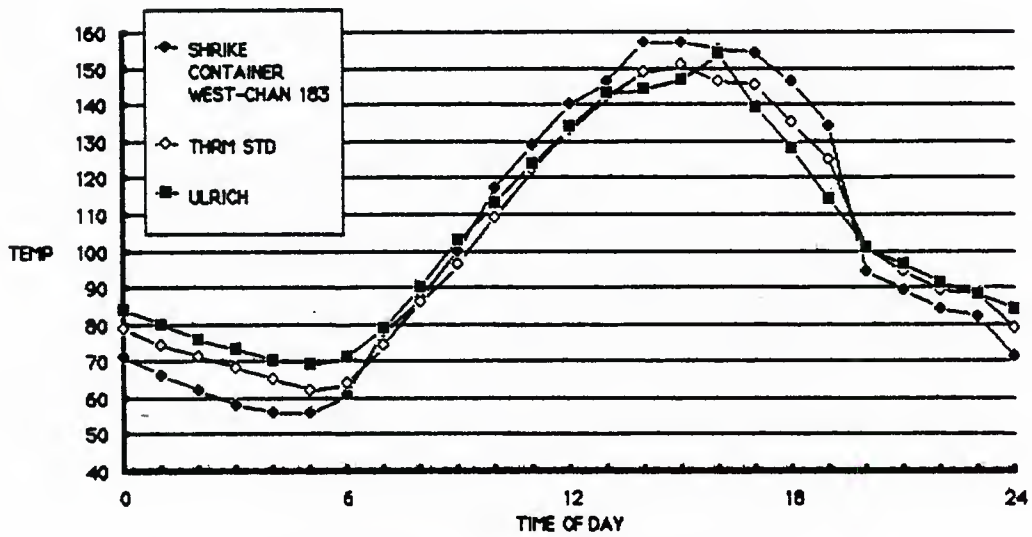

FIGURE 12. Shrike Container West Side, 28 June 1974 Experimental Data.

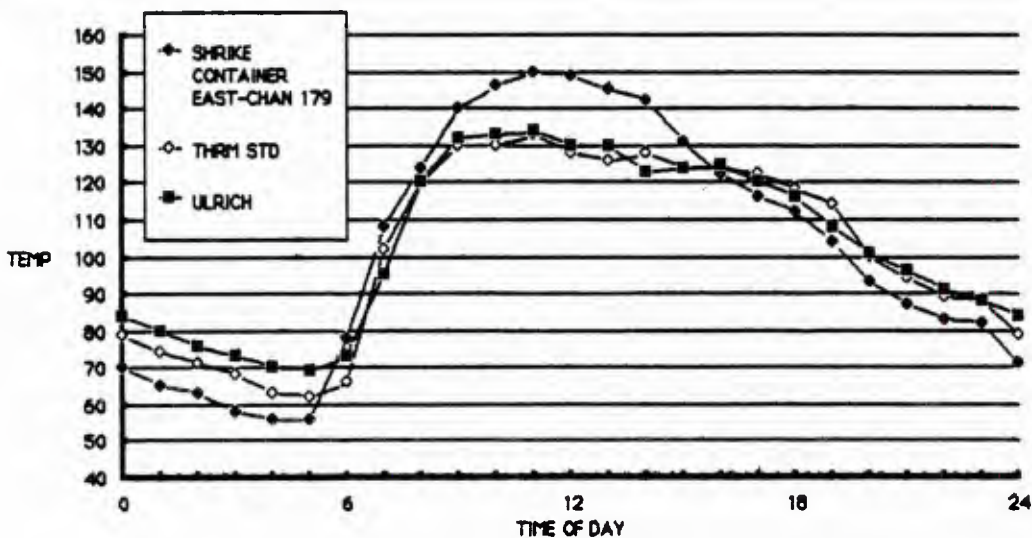

FIGURE 13. Shrike Container East Side, 28 June 1974 Experimental Data.

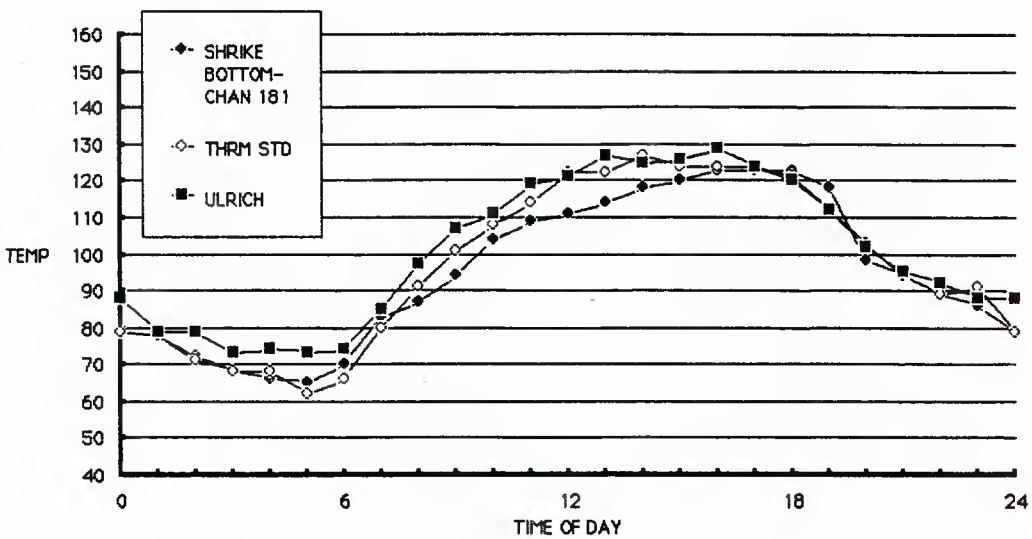

FIGURE 14. Sidewinder Container, Bottom, 28 June 1974 Experimental Data.

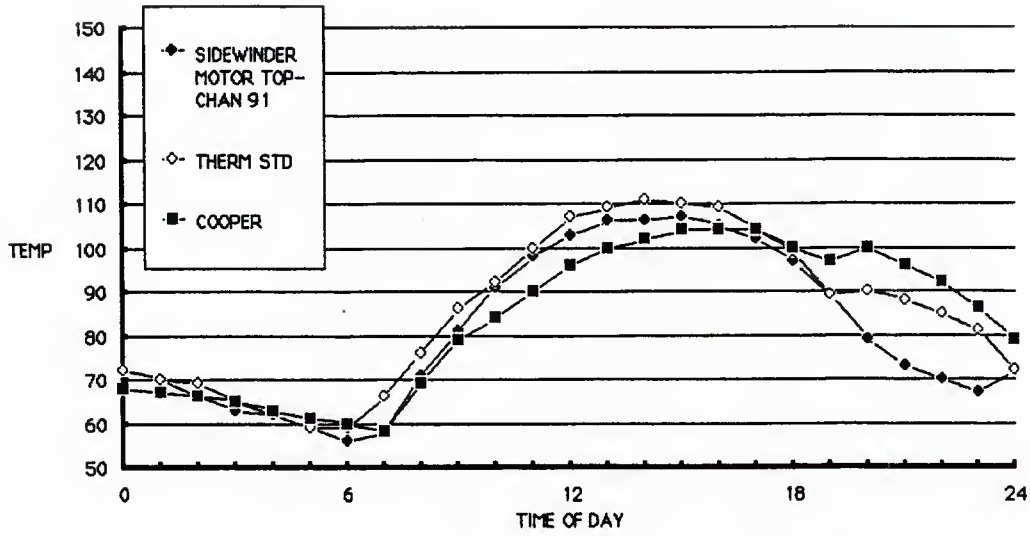

FIGURE 15. Sidewinder Motor Top, 29 August 1974 Experimental Data.

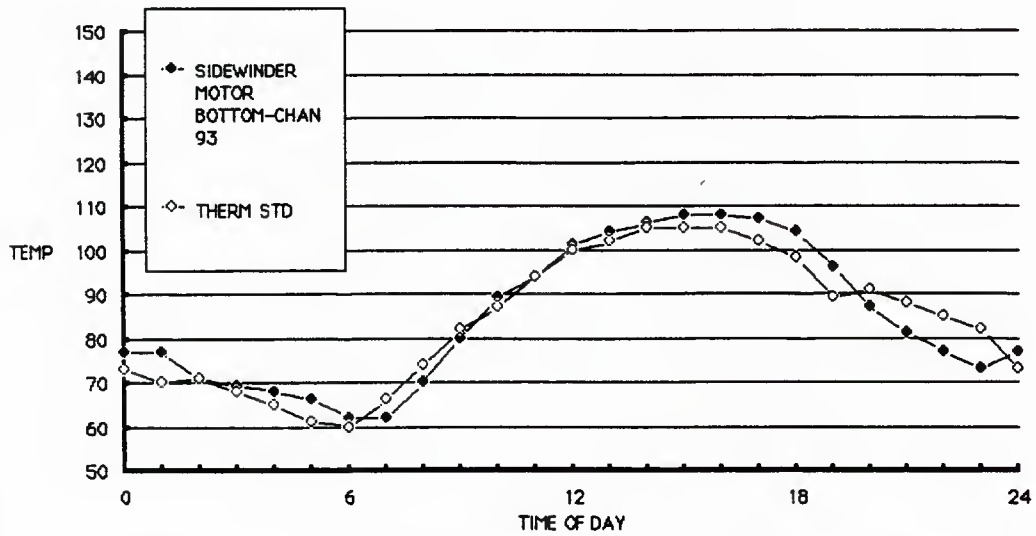

FIGURE 16. Sidewinder Motor Bottom, 29 August 1974 Experimental Data.

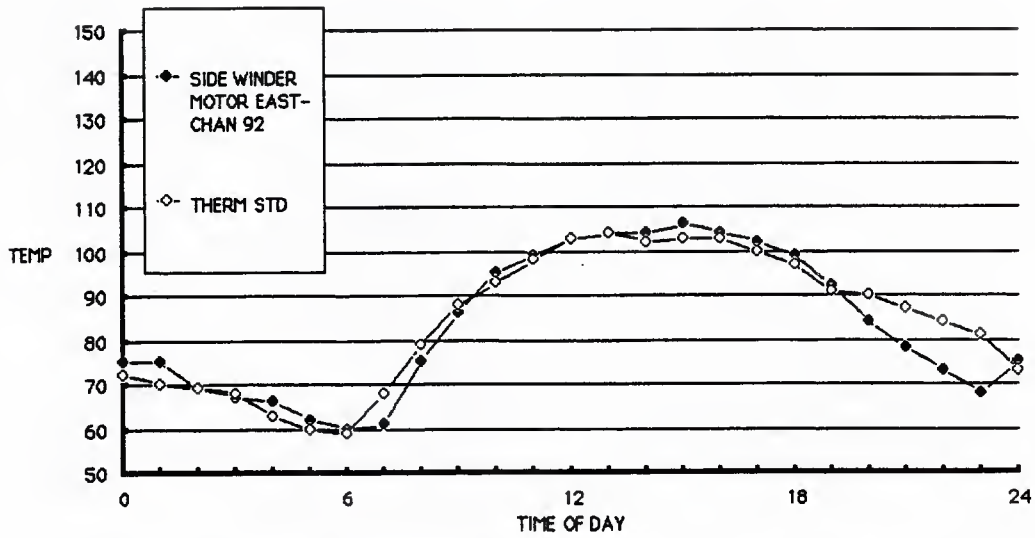

FIGURE 17. Sidewinder Motor, East, 29 August 1974 Experimental Data.

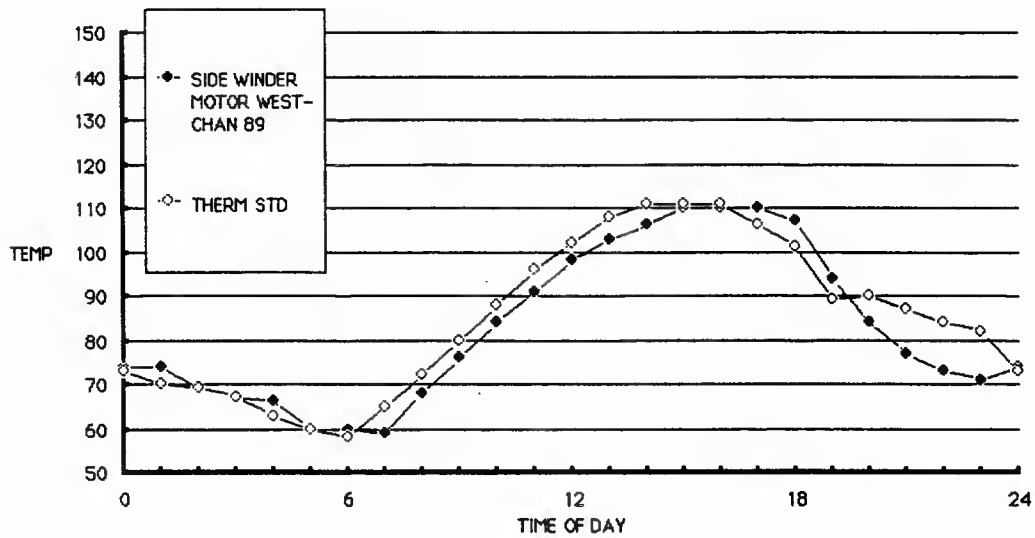

FIGURE 18. Sidewinder Motor, West, 29 August 1974 Experimental Data.

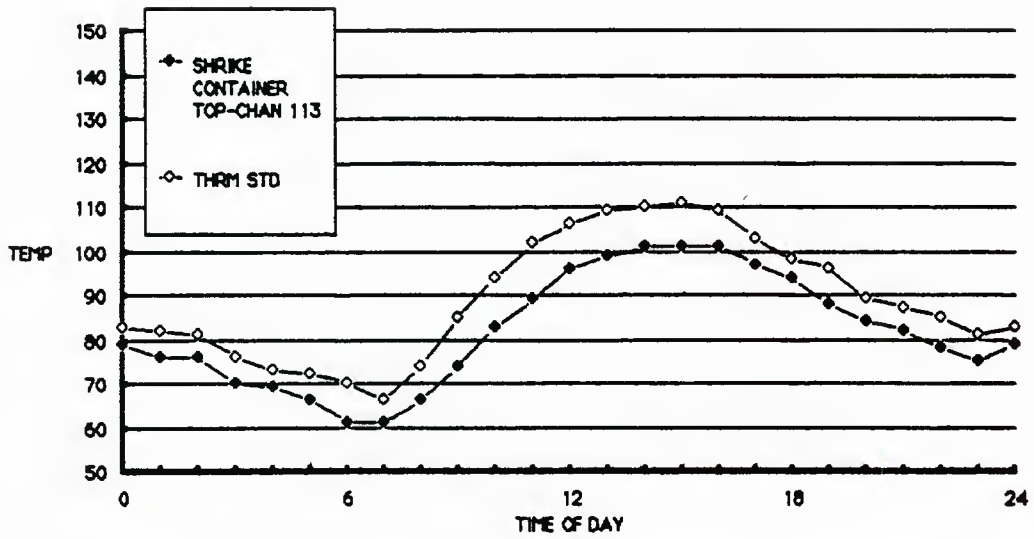

FIGURE 19. Shrike Container, Top, 11 September 1974 Experimental Data.

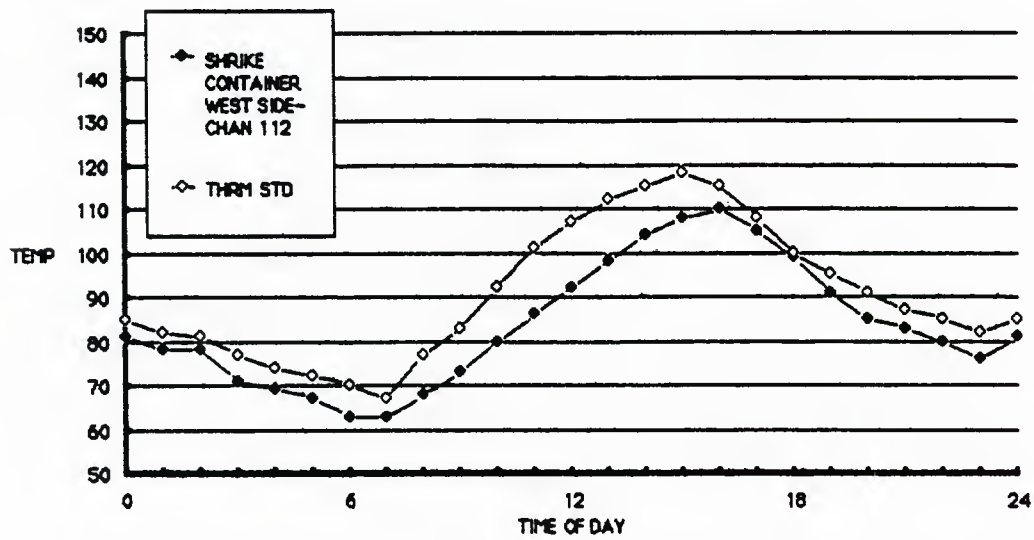

FIGURE 20. Shrike Container, West, 11 September 1974 Experimental Data.

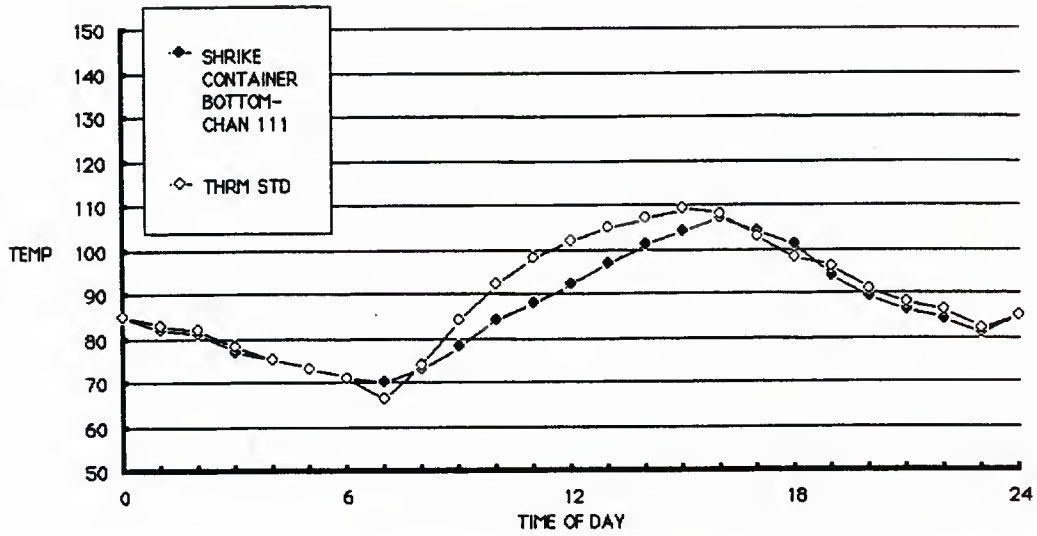

FIGURE 21. Shrike Container, Bottom, 11 September 1974 Experimental Data.

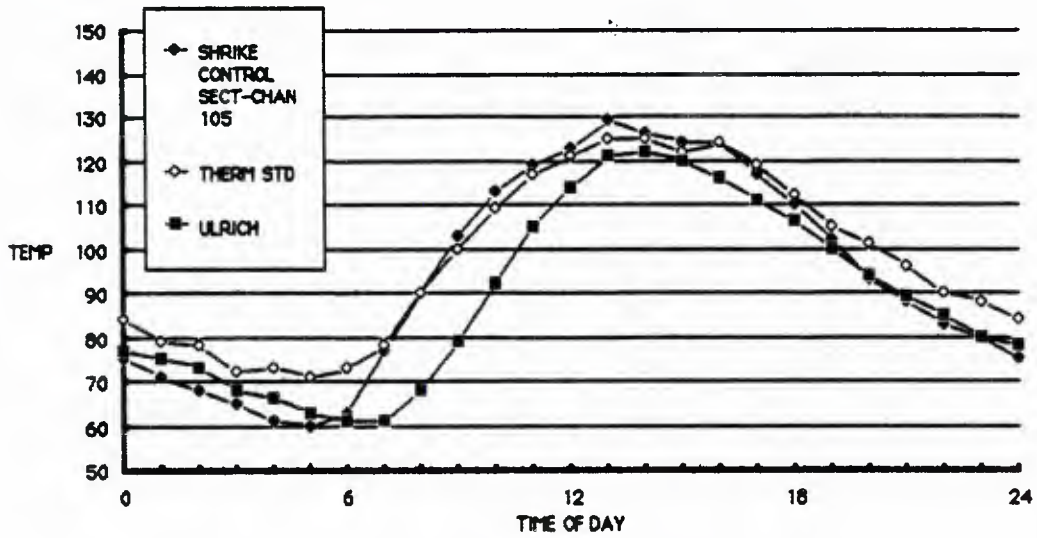

FIGURE 22. Shrike Control Section, Top Outside Skin, 12 June 1974 Experimental Data.

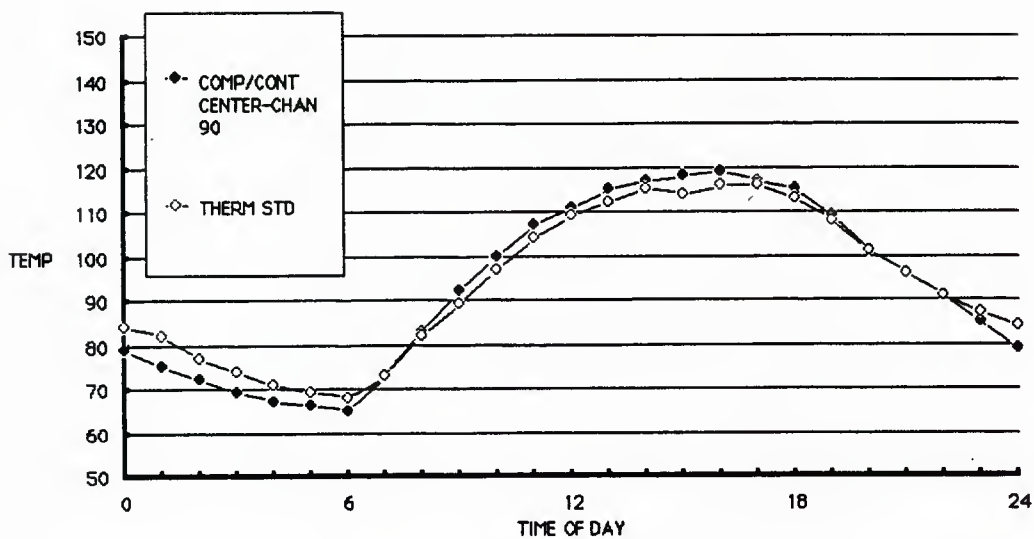

FIGURE 23. Shrike Computer/Control Center, 12 June 1974 Experimental Data.

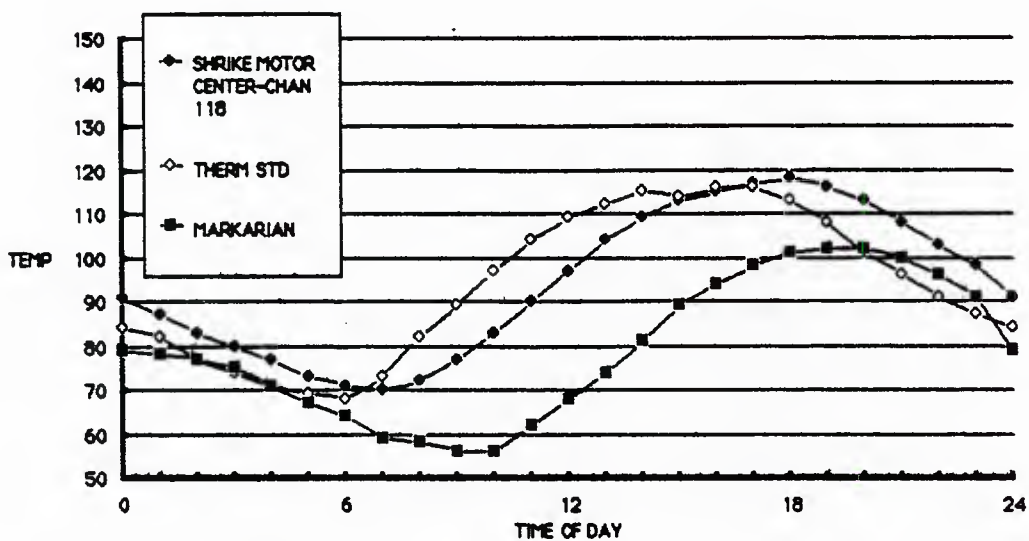

FIGURE 24. Shrike Computer/Control Center, 12 June 1974 Experimental Data.

Figure 25 shows similar comparisons for the 28 June data on the Shrike motor inside the container (top position). Included are predictions from Markarian and Cooper as well as the thermal standard. Predictions from none of the methods compared closely to the experimental values for this low mass container.

Figure 26 shows comparisons of Cooper's and the thermal standard predictions for the top of the Shrike guidance section in the container (28 June data). The thermal standard, being more massive, lags the experimental data by about 1 hour. Cooper's predictions did not lag, but the method underpredicted by about 15°F.

The thermal standard method compared very well with the experimental data on the Sidewinder inside motor location (29 August data), as shown in Figure 27. The reason that the thermal standard compares better with the Sidewinder than with the Strike is probably because it is the same size as the Sidewinder and smaller than the Shrike. (This kind of reasoning fits only the inside temperature comparisons.)

For the light-colored Sidewinder control section, the thermal standard prediction method compared very well with experimental. For this case, the absorptivity to solar wavelengths was assumed to be 0.5. The results are shown in Figure 28.

Based on the number of comparisons shown, one can conclude that there are many more thermal standard comparisons than comparisons using other analytical methods. The reason is that the thermal standard method is much easier. The 24 hourly calculation points can be finished, even on a hand calculator, in only 5 to 10 minutes. The top, east side, west side, bottom, and center can all be done and plotted by hand in less than 1/2 hour. Usually the analytical methods require much more detailed geometric and thermal property information and require more assumptions of unknown properties and, therefore are less accurate because they do not have the advantage of being in the test site. Also, the experience of using the thermal standard was directly applicable to the type of predictions used in the comparisons desired in this series of tests.

By using the best reasoning from values of thermal properties found in various technical references, it is likely that an experienced heat transfer analyst would have differences between his analytical method and experimental results of 15 to 20°F when the object is 40 to 60°F above ambient air temperature. In percentage terms, this would be 25 to 50% of the temperature difference. Part of the difference is experimental, but most is in the following unknowns: absorptivity of the surface to solar wavelength radiant energy, solar energy rate on nonhorizontal surfaces, convection heat transfer coefficient between the surface and the ambient air, effective sky temperature, and lumping of the thermal masses versus the actual distribution of thermal mass.

This work was done more than 10 years ago. If a similar project were to be attempted in 1986, the only difference would be the experience of the analyzers. There are no new analytical tools that could provide better solutions or more accurate answers. If the same thermodynamicists were used, the predictions would be slightly better because of their added experience. If new analysts were chosen with approximately similar experience as the analysts had 10 years ago, the errors would be essentially the same.

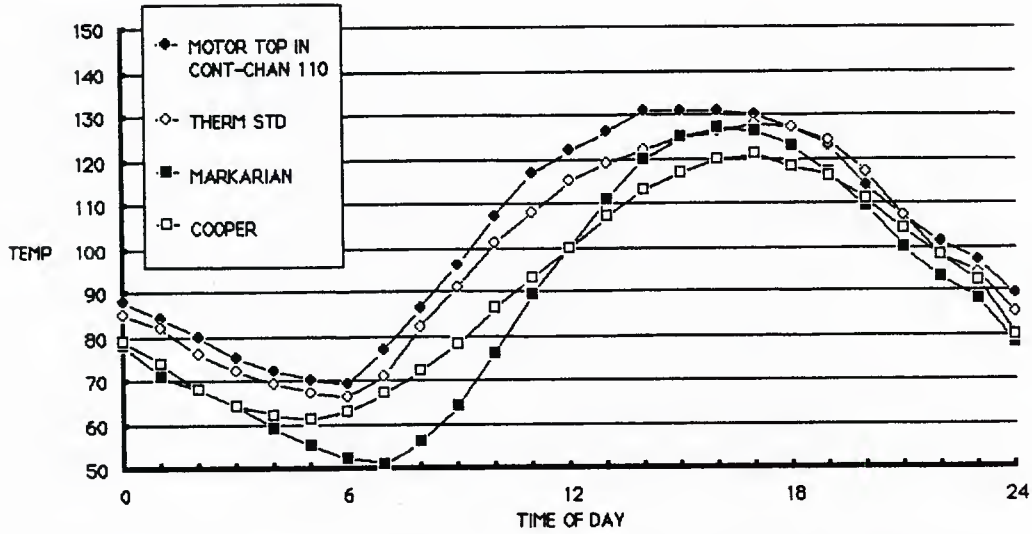

FIGURE 25. Shrike Motor in Container, Top, 28 June 1974 Experimental Data.

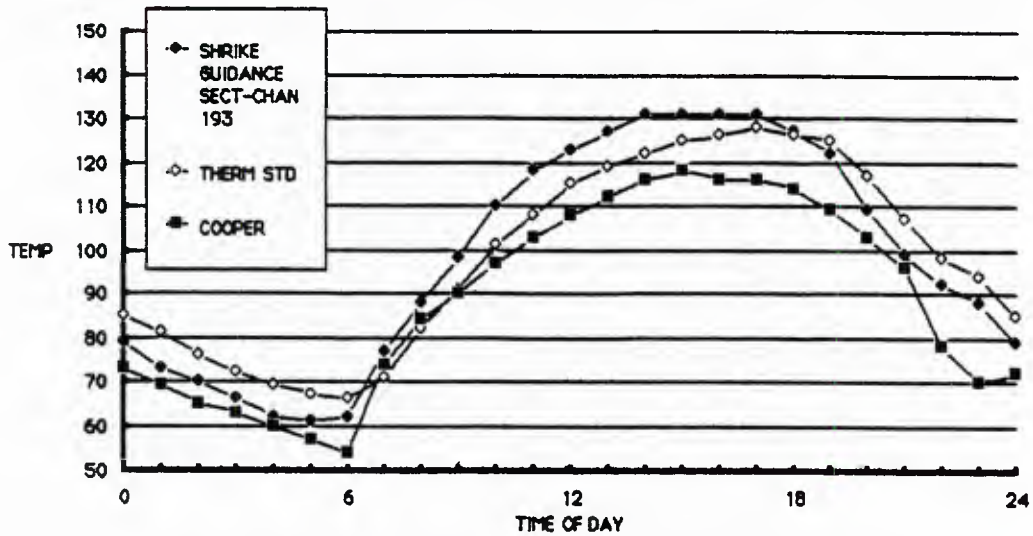

FIGURE 26. Shrike Guidance Section in Container, Top Outside Skin, 28 June 1974 Experimental Data.

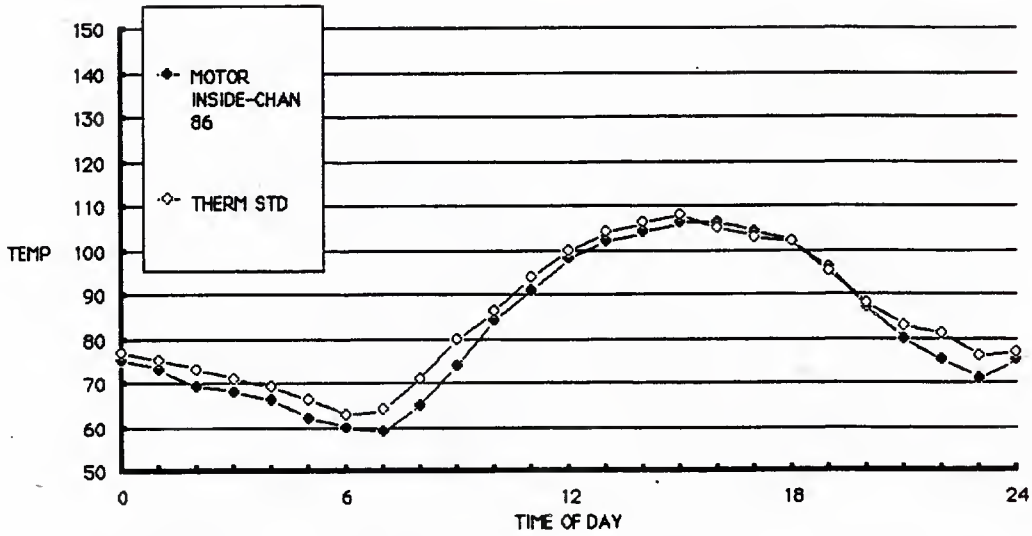

FIGURE 27. Sidewinder Motor, Inside, 29 August 1974 Experimental Data.

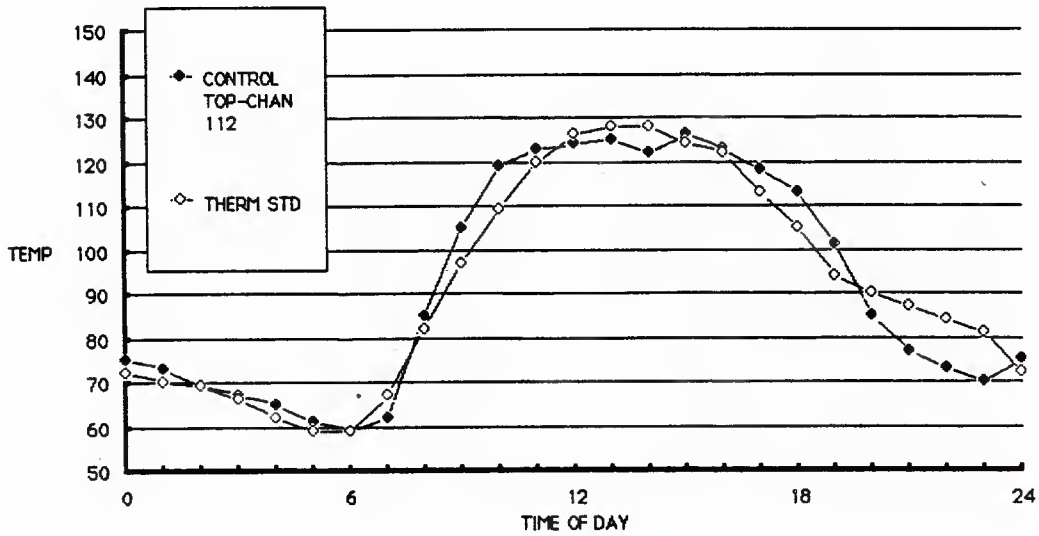

FIGURE 28. Sidewinder Control Section, Top, 29 August 1974 Experimental Data.

CONCLUSIONS

Based on the discussion presented in this report, the following conclusions have been made:

1. Accuracy in the experimental data is probably no better than $\pm 5^{\circ}\text{F}$.
2. Analytical errors are probably another $\pm 15^{\circ}\text{F}$.
3. The total expected difference between measured and calculated temperatures is, therefore, about 30°F .
4. The major causes of this difference are the surface radiation properties that are estimated and the effective sky temperature.
5. The thermal standard prediction method is much better than the purely analytical methods because it has the benefit of having "been there."
6. A repeat of this demonstration today would probably not result in closer predictions to the experimental temperatures.

REFERENCES

1. J. L. Threkeld. *Thermal Environmental Engineering*. New Jersey, Prentice-Hall, Inc., 1962. P. 327.
2. Naval Weapons Center. *Evolution of the NWC Thermal Standard. Part 1. Concept*, by R. D. Ulrich. China Lake, Calif., NWC, February 1970. (NWC TP 4834, Part 1; publication UNCLASSIFIED.)
3. S. B. Idso and R. D. Jackson. "Thermal Radiation From the Atmosphere," *J. of Geophysical Research*, Vol. 74, No. 23 (October 1969), p. 5397.
4. Naval Weapons Center. *Evolution of the NWC Thermal Standard. Part 2. Comparison of Theory With Experiment*, by R. D. Ulrich. China Lake, Calif., NWC, August 1971. (NWC TP 4834, Part 2; publication UNCLASSIFIED.)
5. ———. *Evolution of the NWC Thermal Standard. Part 3. Application and Evaluation of the Thermal Standard in the Field*, by R. D. Ulrich and H. C. Schafer. China Lake, Calif., NWC, August 1977. (NWC TP 4834, Part 3; publication UNCLASSIFIED.)

Appendix A

THERMOCOUPLE LOCATIONS, 12 JUNE 1974 TESTS

This appendix contains sketches showing the locations of the copper-constantan thermocouples used in the 12 June 1974 tests. The missile was an all-up Shrike, model AGM-45A-3. Its nose was pointed north. It had an inert plastic, cast warhead. The motor was filled with dry desert sand. It had no fins.

GUIDANCE SECTION

RADOME

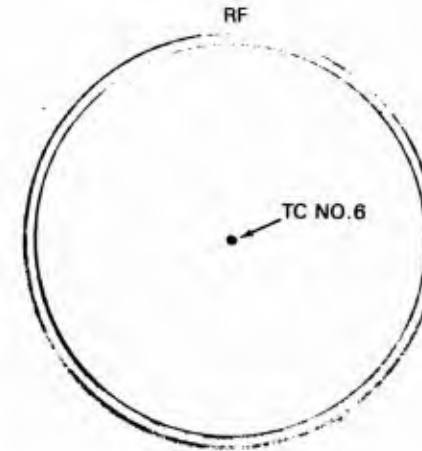
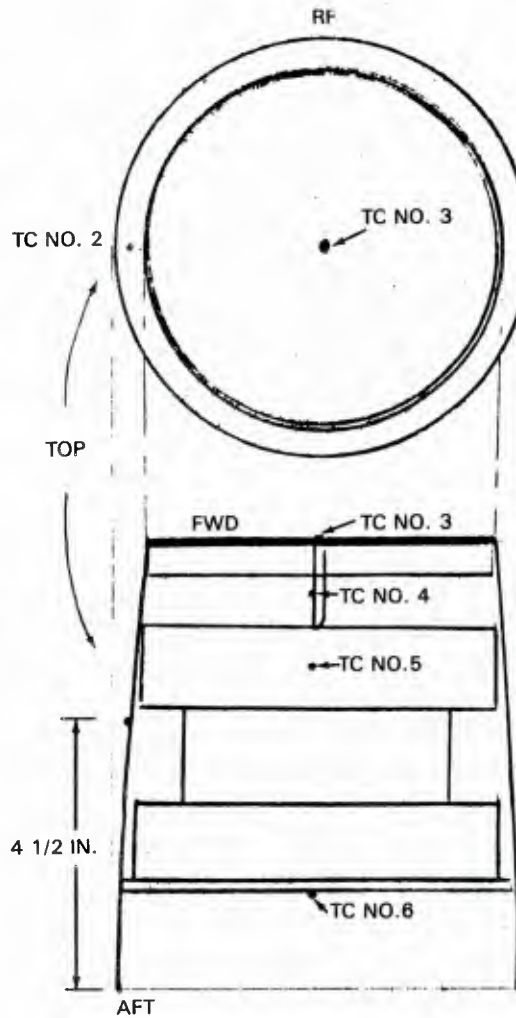
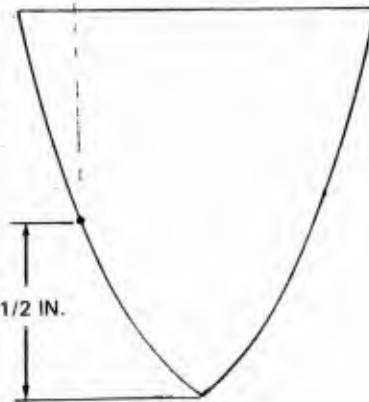
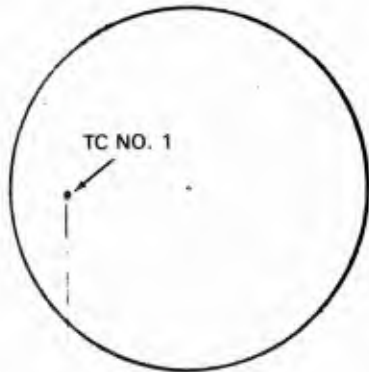

DATA CHANNEL	TC NO.	LOCATION
192	1	TOP OUTSIDE SKIN (NON METAL)
193	2	TOP OUTSIDE SKIN, ALUM.
194	3	CENTER SURFACE ANTENNA NONE METAL
195	4	INSIDE CENTER ANTENNA RF ON ALUM. ROD
196	5	INSIDE CENTER ANTENNA RF AIR
197	6	AFT CENTER RF ANT. ON ALUM. SURFACE

GUIDANCE COMPUTER SECTION

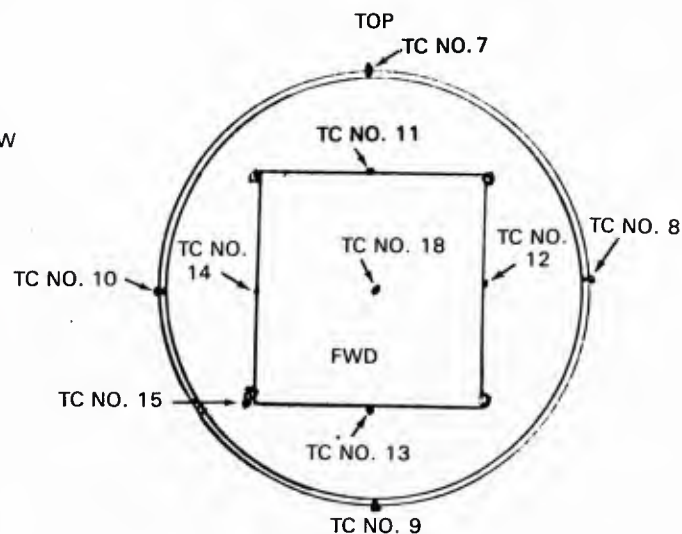
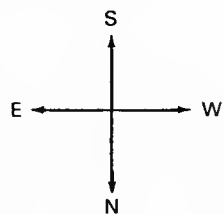
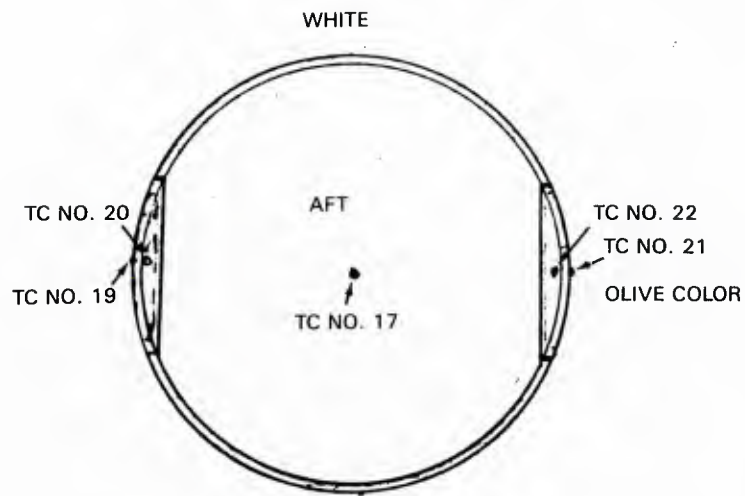

39

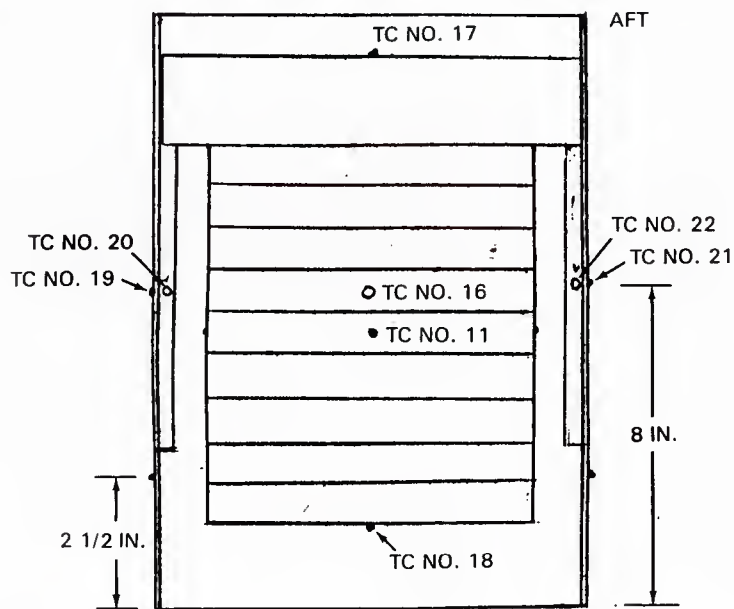

DATA CHANNEL	TC NO.	LOCATION
198	7	TOP OUTSIDE SKIN
199	8	WEST SIDE, OUTSIDE, SKIN
81	9	BOTTOM, OUTSIDE, SKIN
82	10	EAST SIDE, OUTSIDE SKIN
83	11	TOP SKIN, CENTER MODULE
84	12	WEST SKIN, CENTER MODULE
85	13	BOTTOM SKIN, CENTER MODULE
86	14	EAST SKIN, CENTER MODULE
87	15	BOTTOM EAST, MODULE BOLT
88	16	CENTER AIR, 4TH MODULE FROM AFT
89	17	AFT CENTER ON THIN ALUM. SURFACE
90	18	FWD CENTER, ALUM. SURFACE
91	19	EAST ANTENNA FUZE, OUTSIDE SURFACE
92	20	EAST ANTENNA FUZE, CENTER
93	21	WEST ANTENNA FUZE, OUTSIDE SURFACE
94	22	WEST ANTENNA FUZE, CENTER

WARHEAD SECTION TOP

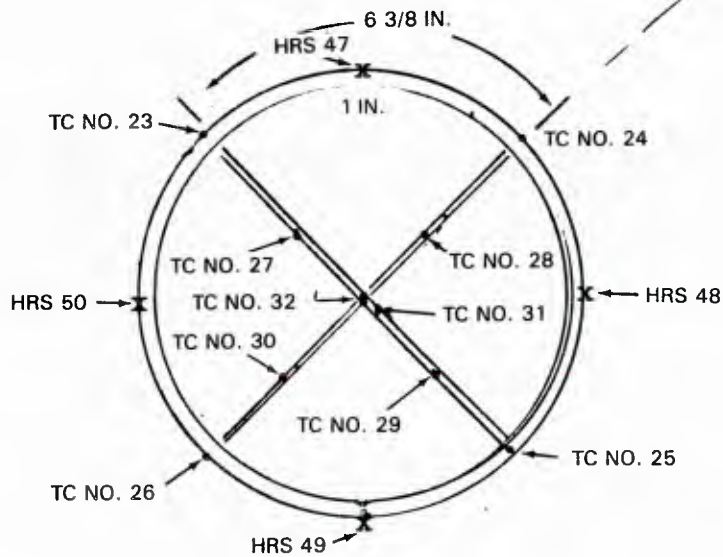
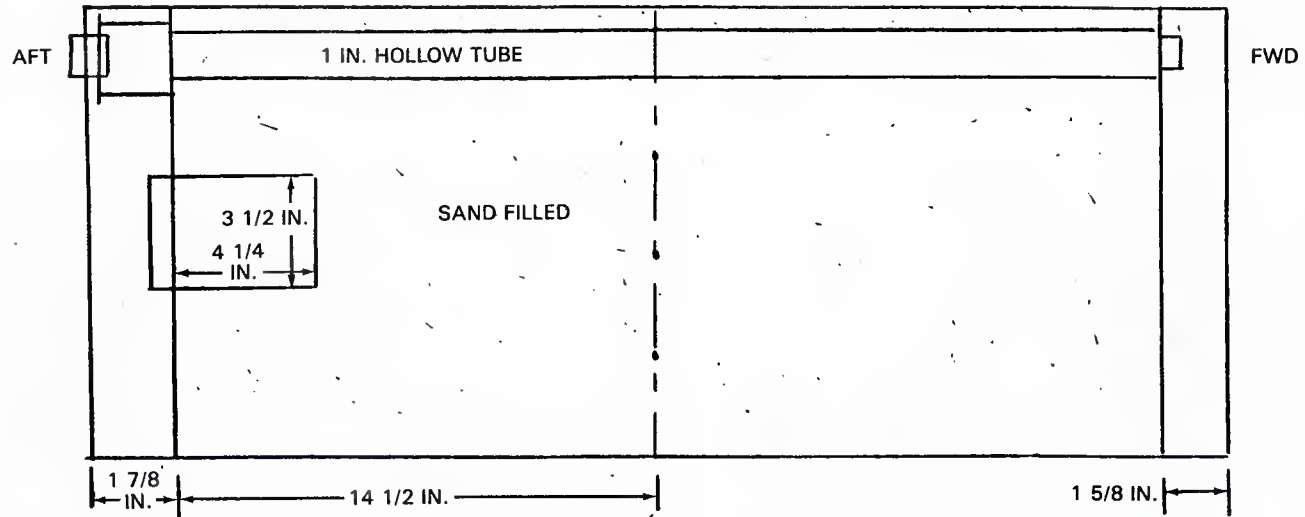

DATA CHANNEL	TC NO.	LOCATION	
95	23	OUTSIDE SKIN, 10:30 O'CLOCK EAST	
96	24	OUTSIDE SKIN, 1:30 O'CLOCK WEST	
97	25	OUTSIDE SKIN, 4:30 O'CLOCK WEST	
98	26	OUTSIDE SKIN, 7:30 O'CLOCK EAST	
99	27	INSIDE, 1 7/8 IN. FROM CENTER 10:30 EAST	
100	28	INSIDE, 1 7/8 IN. FROM CENTER 1:30 WEST	
101	29	INSIDE, 1 7/8 IN. FROM CENTER 4:30 WEST	
102	30	INSIDE, 1 7/8 IN. FROM CENTER 7:30 EAST	
103	31	INSIDE CENTER	
104	32	INSIDE CENTER	
10	HRS 47	0.002 mV/FT ² HR	TOP OUTSIDE
11	HRS 48	0.002 mV/FT ² HR	WEST SIDE
12	HRS 49	0.002 mV/FT ² HR	BOTTOM
13	HRS 50	0.002 mV/FT ² HR	EAST

NWC TTP 5923, Part 1

CONTROL SECTION

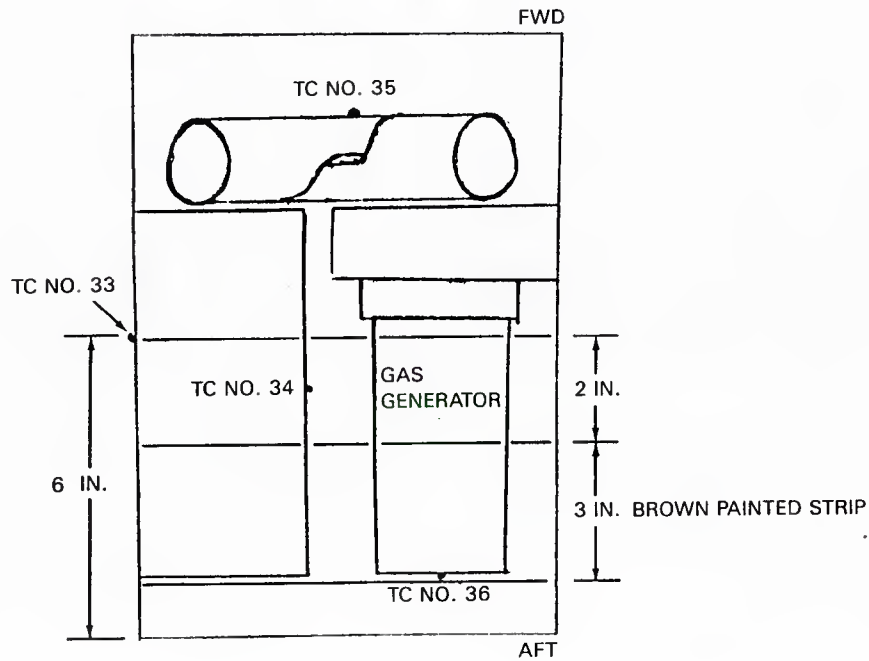
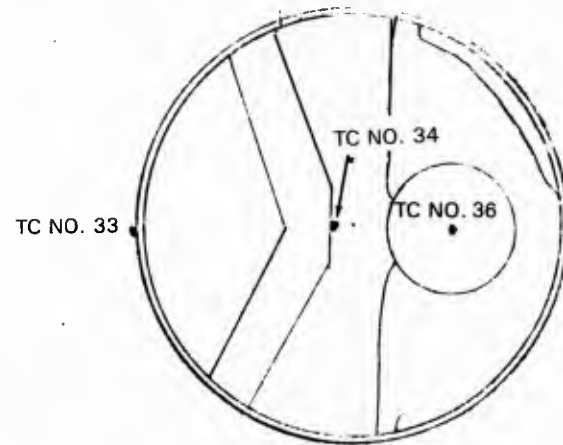
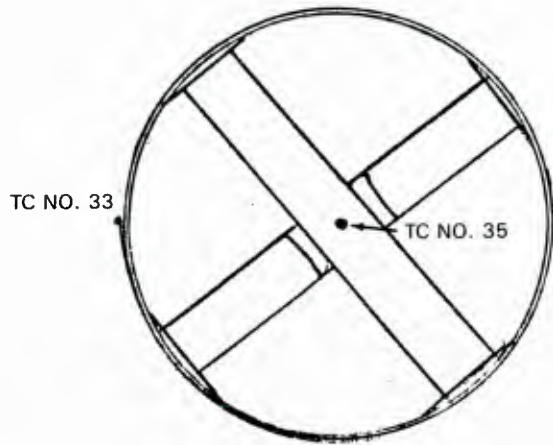

DATA CHANNEL	TC NO.	LOCATION
105	33	TOP OUTSIDE SKIN, ALUM.
106	34	CENTER OF SECTION, NON METAL
107	35	BULKHEAD, STEEL
108	36	TOP OUTSIDE SURFACE OF GAS GEN. STEEL

MOTOR SECTION

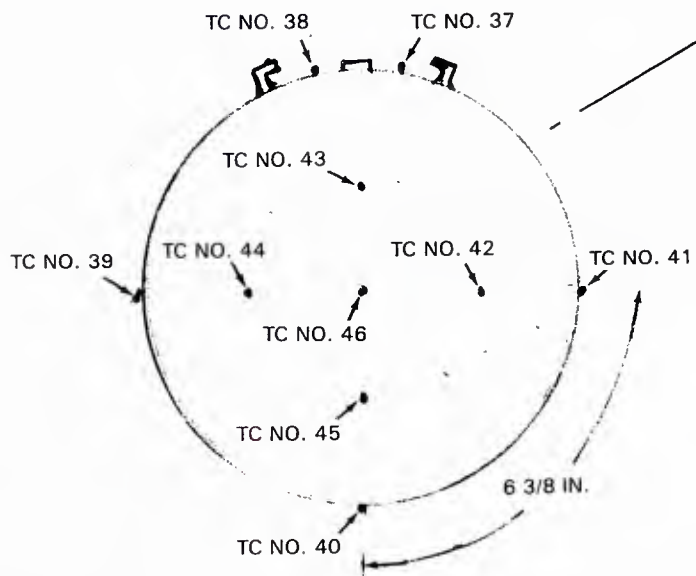
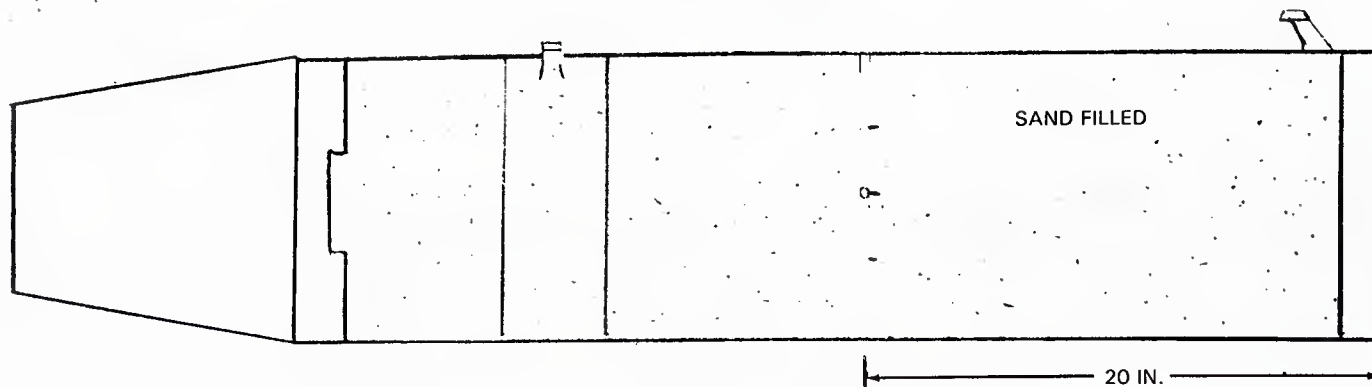

DATA CHANNEL	TC NO.	LOCATION
109	37	TOP OUTSIDE SKIN, SLIGHTLY WEST
110	38	TOP OUTSIDE SKIN, SLIGHTLY EAST
111	39	OUTSIDE SKIN, EAST SIDE
112	40	OUTSIDE SKIN, BOTTOM
113	41	OUTSIDE SKIN, WEST SIDE
114	42	INSIDE, 1 7/8 IN. FROM CENTER, WEST
115	43	INSIDE, 1 7/8 IN. FROM CENTER, TOP
116	44	INSIDE, 1 7/8 IN. FROM CENTER, EAST
117	45	INSIDE, 1 7/8 IN. FROM CENTER, BOTTOM
118	46	INSIDE CENTER

Appendix B

THERMOCOUPLE LOCATIONS, 28 JUNE 1974 TESTS

This appendix contains sketches showing the locations of the copper-constantan thermocouples used in the 28 June 1974 test. The missile was the same as that used in the 12 June tests (an all-up Shrike, model AGM-45A-3) However, this time it was in a single-store container, Mk 399. The nose was pointed north in the container. The container was freshly painted a light navy gray, and it was made of 16-gage steel.

ALL UP SHRIKE IN CONTAINER

NORTH ← → SOUTH

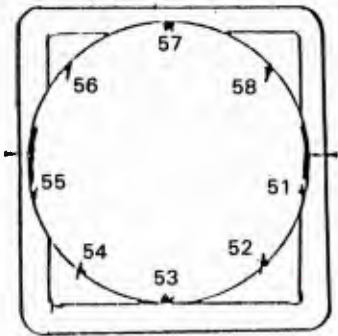
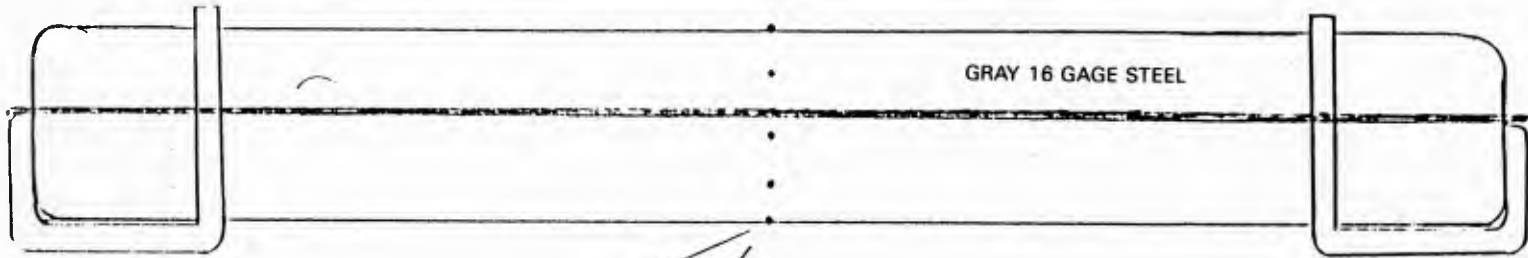

DATA CHANNEL	TC NO.	LOCATION
179	51	EAST SIDE AT 3:30
180	52	EAST SIDE AT 4:30
181	53	BOTTOM
182	54	WEST SIDE AT 7:30
183	55	WEST SIDE AT 8:30
184	56	WEST SIDE AT 10:30
185	57	TOP
186	58	EAST SIDE AT 1:30

GUIDANCE SECTION

RADOME

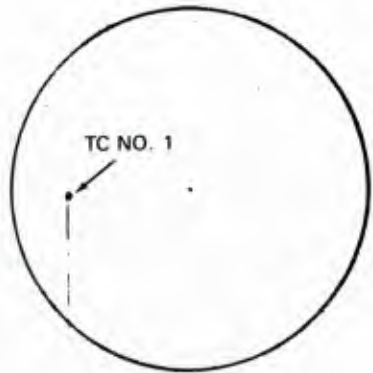

TOP

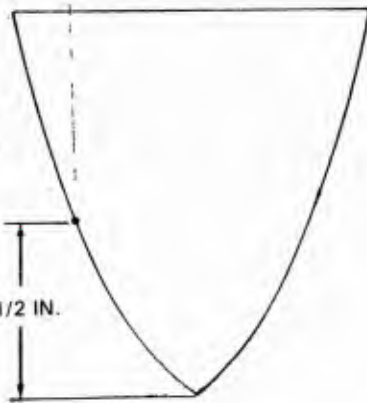

RF

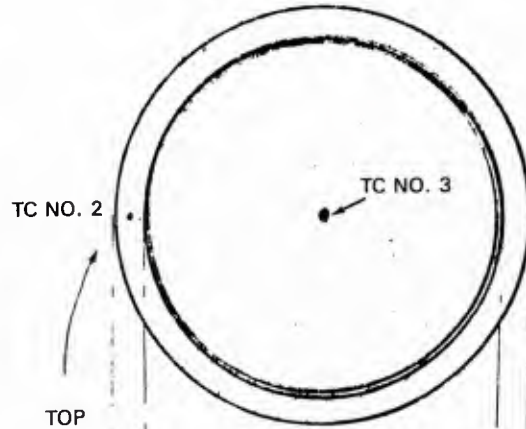

TOP

FWD

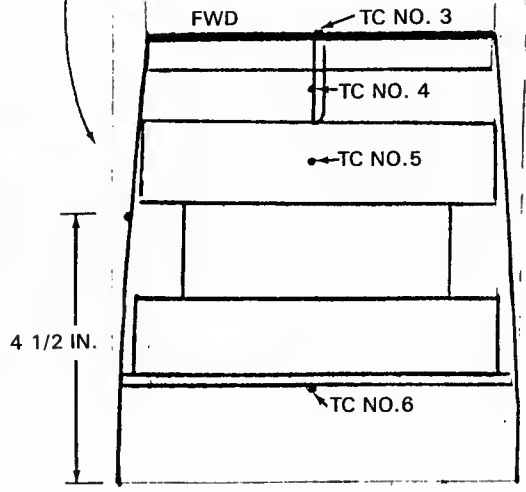

RF

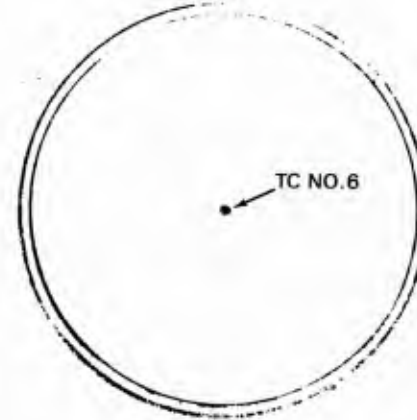

DATA CHANNEL	TC NO.	LOCATION
192	1	TOP OUTSIDE SKIN (NON METAL)
193	2	TOP OUTSIDE SKIN, ALUM.
194	3	CENTER SURFACE ANTENNA NONE METAL
195	4	INSIDE CENTER ANTENNA RF ON ALUM. ROD
196	5	INSIDE CENTER ANTENNA RF AIR
197	6	AFT CENTER RF ANT. ON ALUM. SURFACE

GUIDANCE COMPUTER SECTION

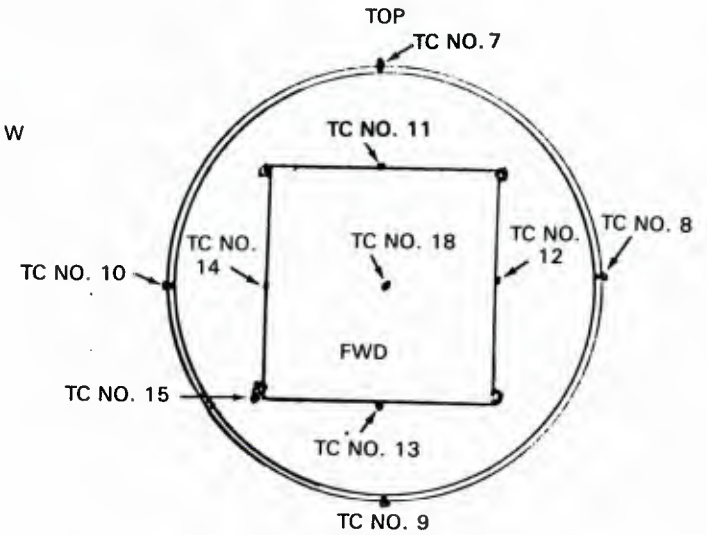
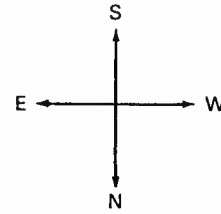
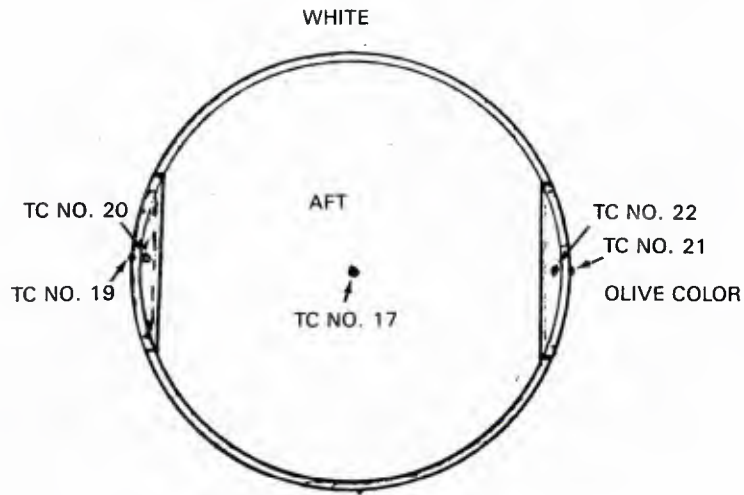

46

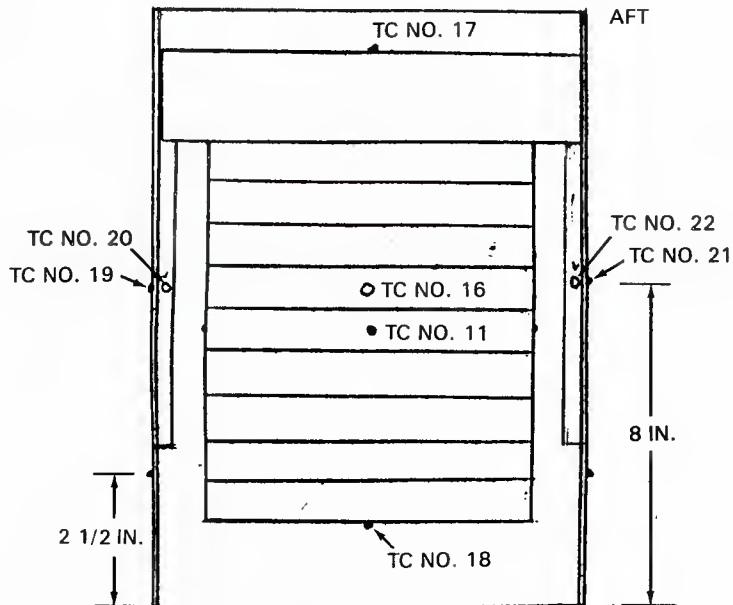

DATA CHANNEL	TC NO.	LOCATION
198	7	TOP OUTSIDE SKIN
199	8	WEST SIDE, OUTSIDE, SKIN
81	9	BOTTOM, OUTSIDE, SKIN
82	10	EAST SIDE, OUTSIDE SKIN
83	11	TOP SKIN, CENTER MODULE
84	12	WEST SKIN, CENTER MODULE
85	13	BOTTOM SKIN, CENTER MODULE
86	14	EAST SKIN, CENTER MODULE
87	15	BOTTOM EAST, MODULE BOLT
88	16	CENTER AIR, 4TH MODULE FROM AFT
89	17	AFT CENTER ON THIN ALUM. SURFACE
90	18	FWD CENTER, ALUM. SURFACE
91	19	EAST ANTENNA FUZE, OUTSIDE SURFACE
92	20	EAST ANTENNA FUZE, CENTER
93	21	WEST ANTENNA FUZE, OUTSIDE SURFACE
94	22	WEST ANTENNA FUZE, CENTER

CONTROL SECTION

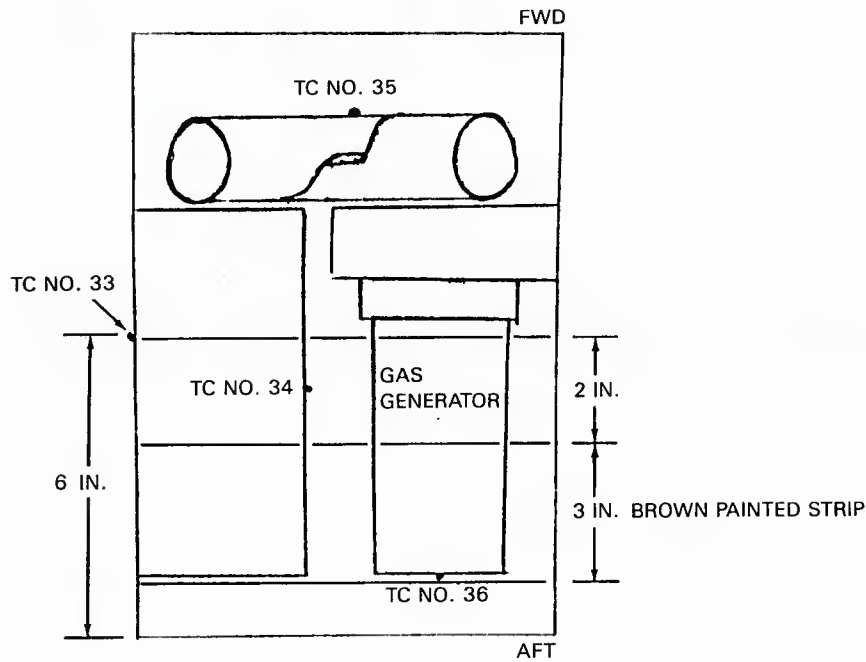
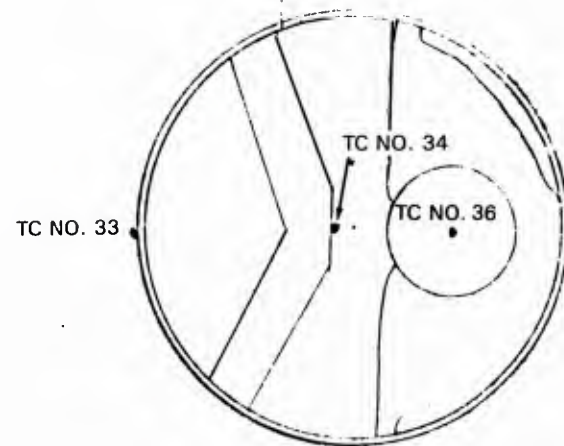
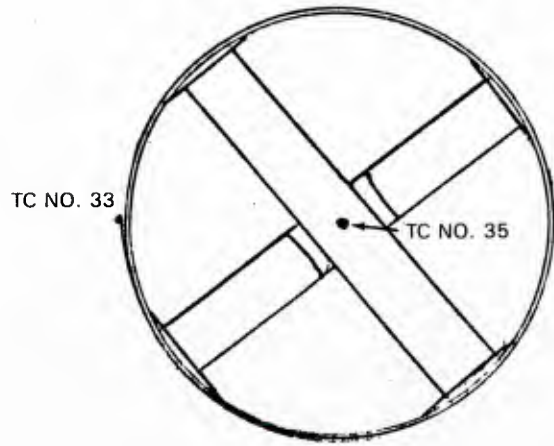

DATA CHANNEL	TC NO.	LOCATION
105	33	TOP OUTSIDE SKIN, ALUM.
106	34	CENTER OF SECTION, NON METAL
107	35	BULKHEAD, STEEL
108	36	TOP OUTSIDE SURFACE OF GAS GEN. STEEL

MOTOR SECTION

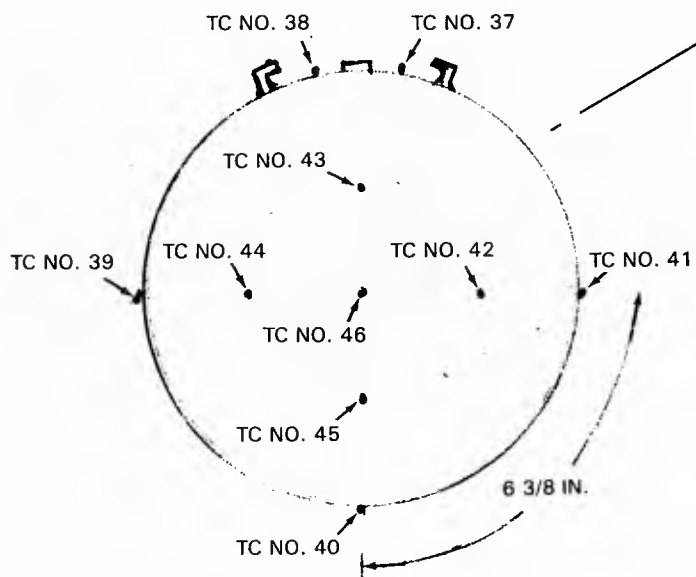
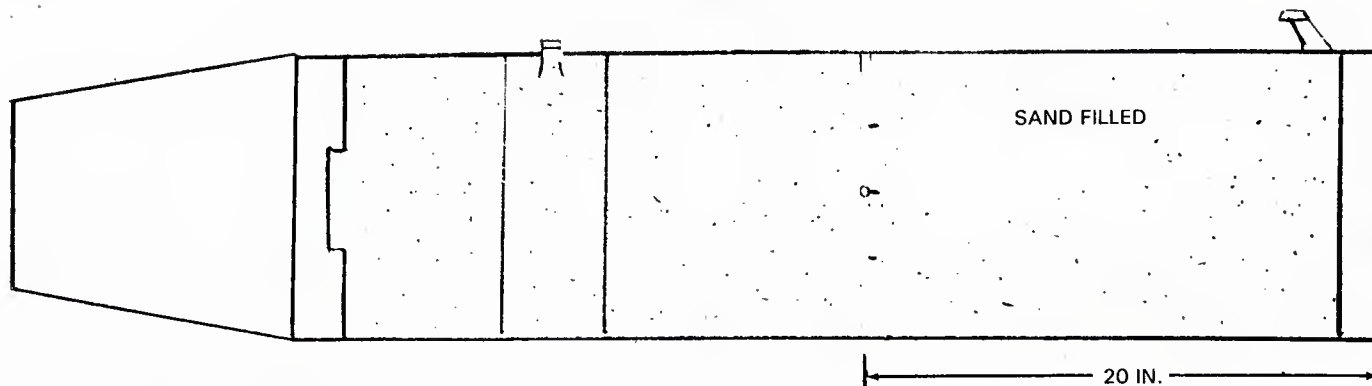

DATA CHANNEL	TC NO.	LOCATION
109	37	TOP OUTSIDE SKIN, SLIGHTLY WEST
110	38	TOP OUTSIDE SKIN, SLIGHTLY EAST
111	39	OUTSIDE SKIN, EAST SIDE
112	40	OUTSIDE SKIN, BOTTOM
113	41	OUTSIDE SKIN, WEST SIDE
114	42	INSIDE, 1 7/8 IN. FROM CENTER, WEST
115	43	INSIDE, 1 7/8 IN. FROM CENTER, TOP
116	44	INSIDE, 1 7/8 IN. FROM CENTER, EAST
117	45	INSIDE, 1 7/8 IN. FROM CENTER, BOTTOM
118	46	INSIDE CENTER

Appendix C

THERMOCOUPLE LOCATIONS, 29 AUGUST 1974 TESTS

This appendix contains sketches showing the locations of the copper-constantan thermocouples used in the 29 August 1974 tests. The missile was an all-up Sidewinder AIM-9H-2, complete with fins. The nose was pointed north. It was freshly painted epoxy white.

SIDEWINDER AIM 9H-2

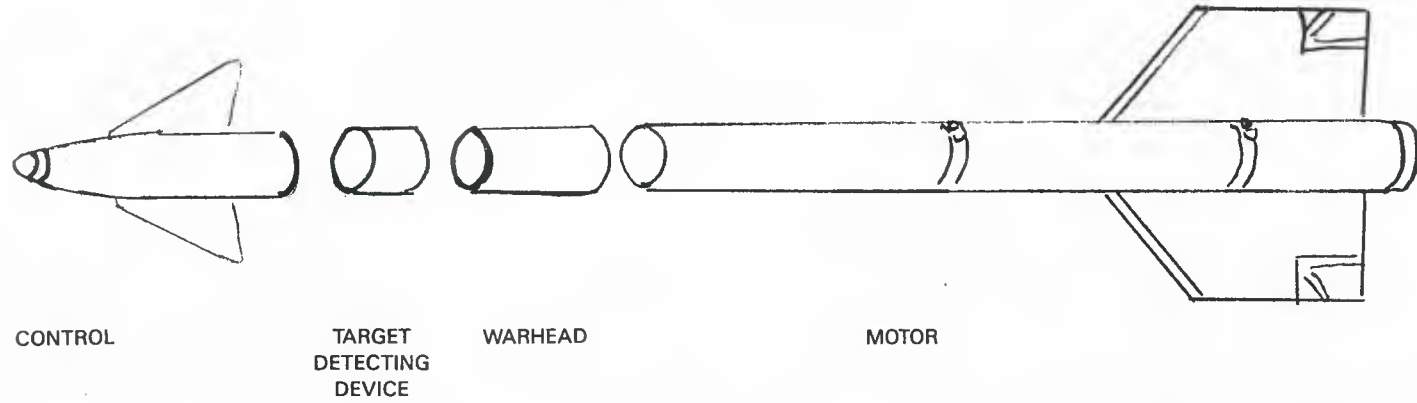

SIDEWINDER AIM 9H-2
CONTROL SECTION

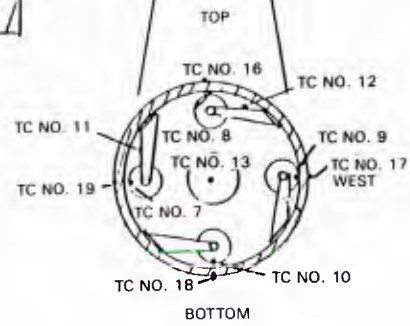
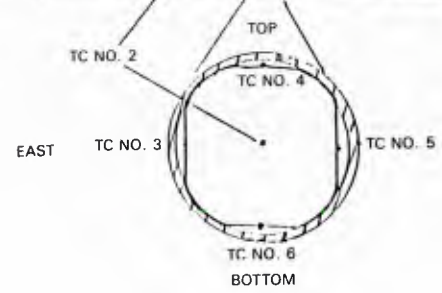
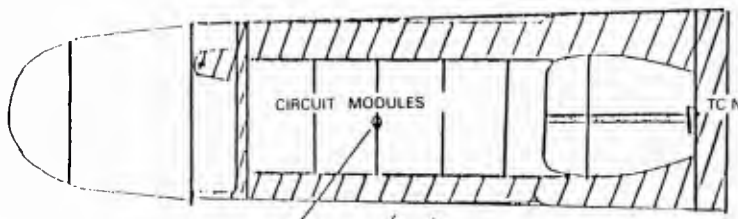
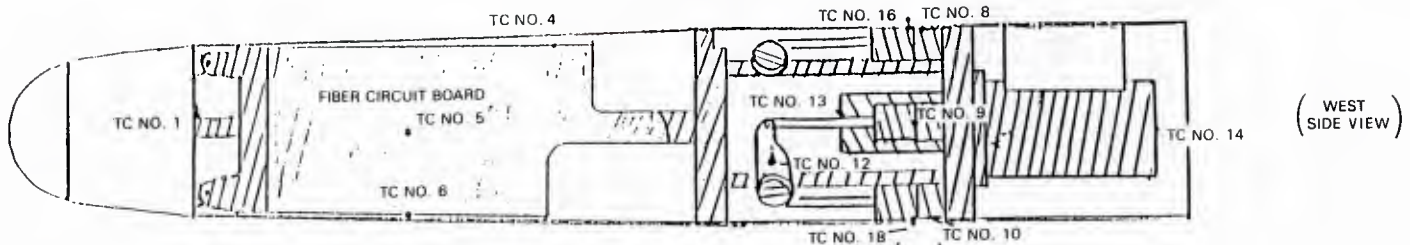

DATA CHANNEL	TC NO.	LOCATION
97	1	ALUM. SURF. CENTER AFT. OF SEEKER SECTION
98	2	CENTER OF CONTROL MODULES
99	3	EAST SIDE CONTROL MODULES
195	4	TOP CONTROL MODULES
84	5	WEST SIDE CONTROL MODULES
102	6	BOT. CONT. MOD.
103	7	SIDE OF EAST ACT.
104	8	TOP ACTUATOR
105	9	WEST ACTUATOR
106	10	BOT. ACTUATOR
107	11	EAST SIDE ACT. ARM AT 10:00
108	12	WEST SIDE ACT. ARM AT 1:00
109	13	
110	14	CENTER SURFACE GAS GENERATOR
101	15	UNDER NUT
112	16	TOP OUTSIDE SURFACE
113	17	WEST OUTSIDE SURFACE
114	18	BOT. OUTSIDE SURFACE
115	19	EAST OUTSIDE SURFACE

SIDEWINDER AIM -9H-2
TARGET DETECTING DEVICE MK 15 MOD 0

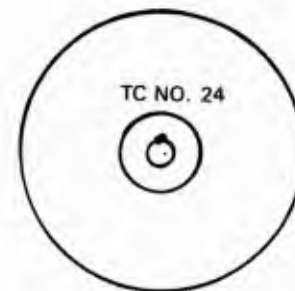
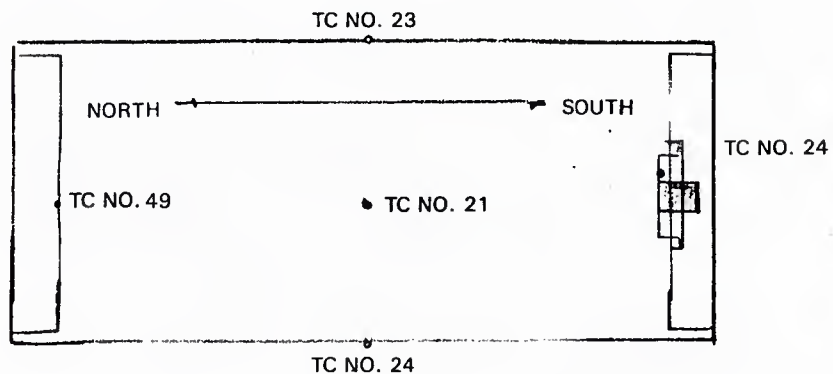
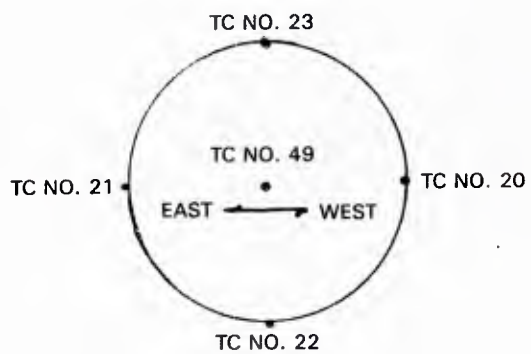

DATA CHANNEL	TC NO.	LOCATION
100	23	TOP OUTSIDE SURFACE (NON-METAL)
116	20	WEST OUTSIDE SURFACE (NON-METAL)
117	21	EAST OUTSIDE SURFACE (NON-METAL)
118	22	BOTTOM OUTSIDE SURFACE (NON-METAL)
119	24	AFT. CENTER ON METAL SURFACE
111	49	FWD. CENTER ON METAL SURFACE

SIDEWINDER MOTOR SECTION

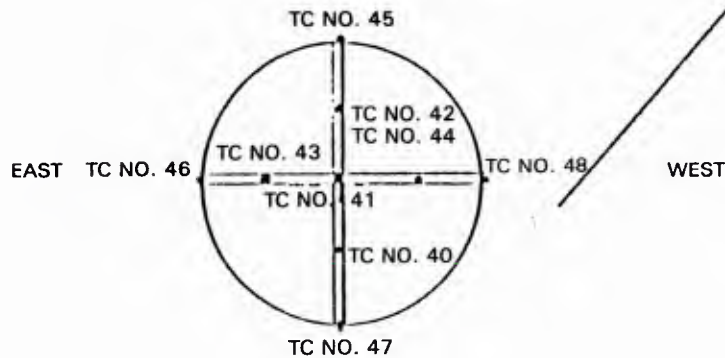
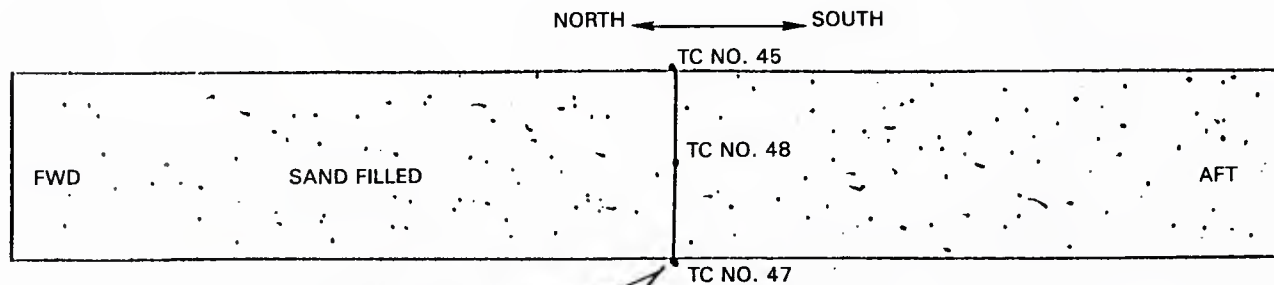

DATA CHANNEL	TC NO.	LOCATION
85	40	INSIDE MOTOR 1 1/4 IN. FROM BOTTOM
86	41	CENTER
87	42	INSIDE MOTOR 1 1/4 IN. FROM TOP
88	43	INSIDE MOTOR 1 1/4 IN. FROM EAST SIDE
89	48	WEST OUTSIDE SURFACE
90	44	INSIDE MOTOR 1 1/4 IN. FROM WEST SIDE
91	45	TOP SURFACE
92	46	EAST OUTSIDE SURFACE
93	47	BOTTOM OUTSIDE SURFACE

SIDEWINDER WARHEAD SECTION
MK 48 MOD 4

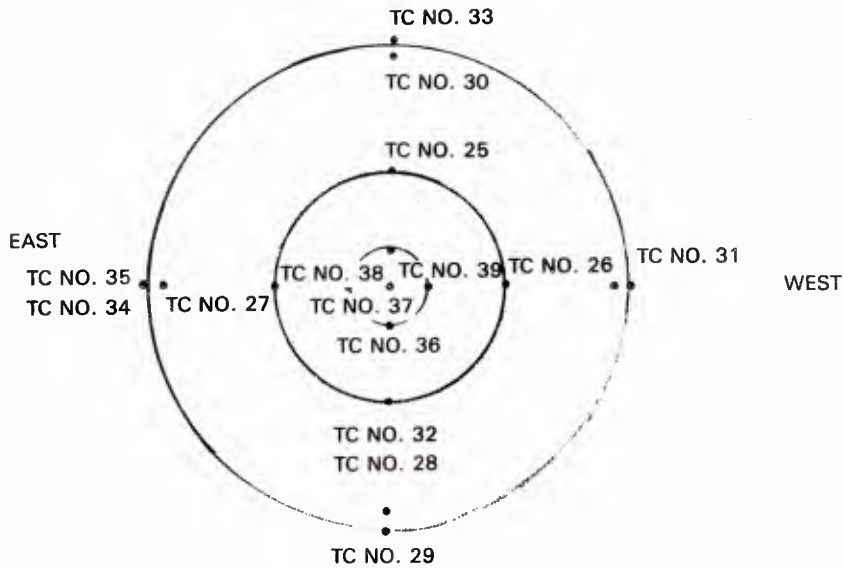
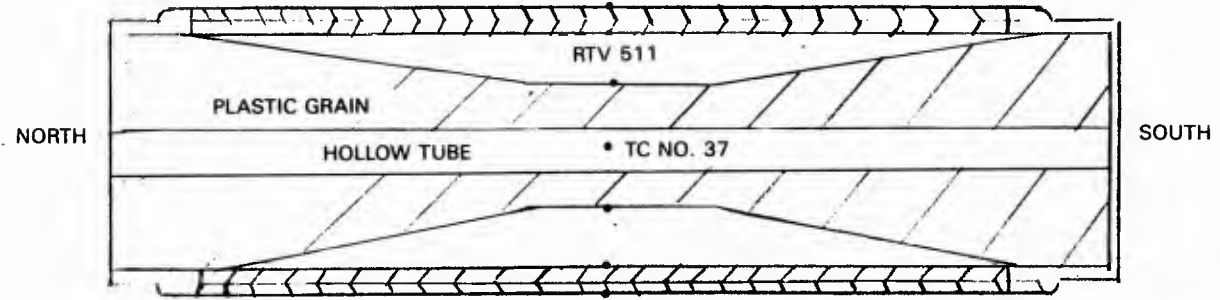

DATA CHANNEL	TC NO.	LOCATION
192	25	TOP SURFACE OF GRAIN
193	26	WEST SURFACE OF GRAIN
194	27	EAST SURFACE OF GRAIN
	28	BOTTOM INSIDE SURFACE OF CASE
196	29	BOTTOM OUTSIDE SURFACE OF CASE
197	30	TOP INSIDE SURFACE OF CASE
198	31	WEST OUTSIDE SURFACE, CASE
199	32	BOTTOM SURFACE GRAIN
81	33	TOP OUTSIDE SURFACE, CASE
82	34	EAST INSIDE SURFACE, CASE
83	35	EAST OUTSIDE SURFACE, CASE
	36	BOTTOM INSIDE SURFACE OF GRAIN
94	37	CENTER OF TUBE IN AIR
95	38	EAST INSIDE SURFACE OF GRAIN
96	39	WEST INSIDE SURFACE OF GRAIN

Appendix D

THERMOCOUPLE LOCATIONS, 11 SEPTEMBER 1974 TESTS

This appendix contains sketches showing the locations of the copper-constantan thermocouples attached to a Sidewinder AIM-9H-2 in a multistore container. The Sidewinder was located in the west side storage location, and three other missiles filled the other storage locations in the container to simulate a full container. Noses of all missiles were pointed north. The multistore container was made of white acrylic material. These tests data were collected on 11 September 1974.

SIDEWINDER MULTISTORE CONTAINER

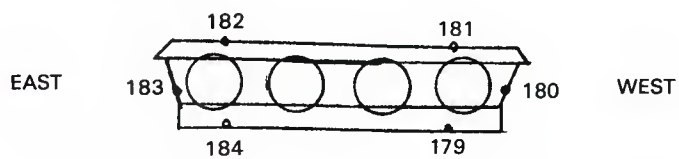
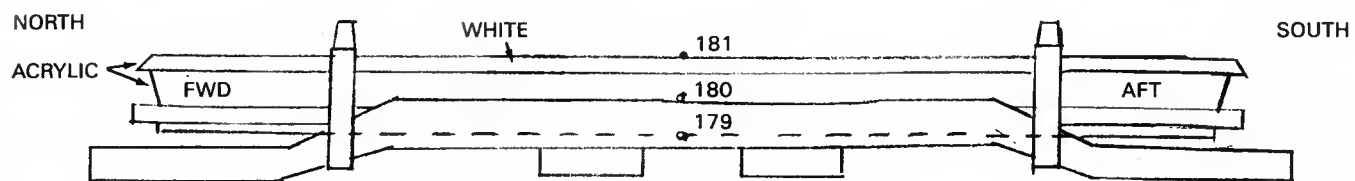
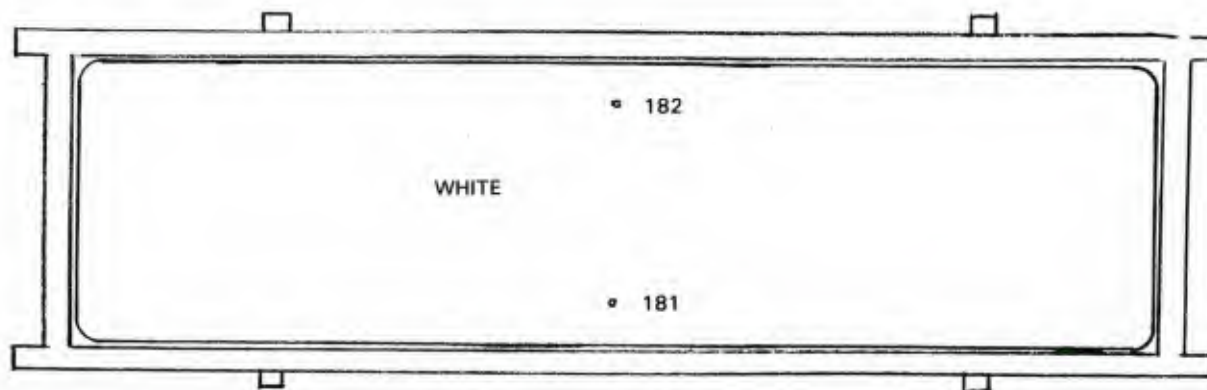

DATA CHANNEL	LOCATION
179	BOTTOM WEST
180	WEST SIDE
181	TOP WEST
182	TOP EAST
183	EAST SIDE
184	BOTTOM EAST

SIDEWINDER AIM 9H 2
CONTROL SECTION

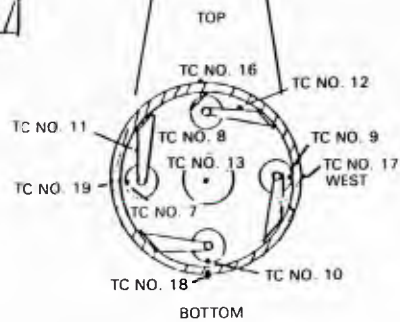
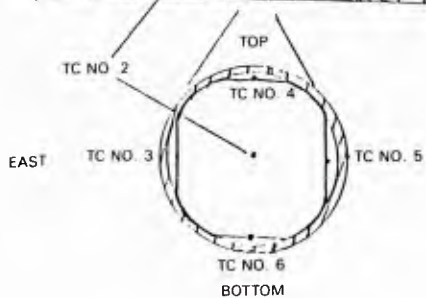
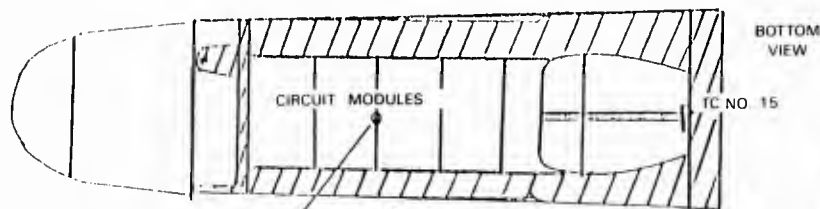
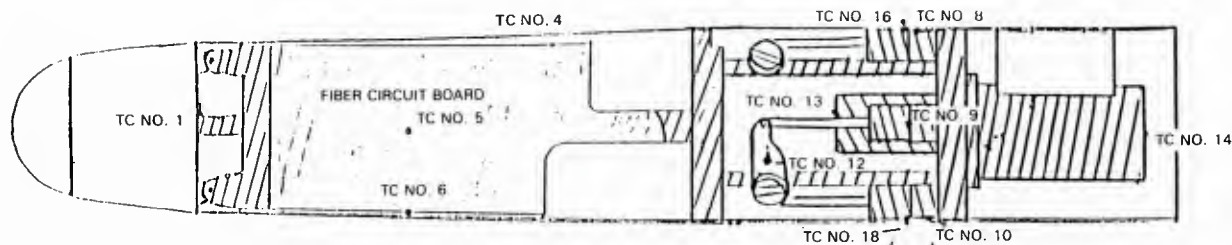

DATA CHANNEL	TC NO.	LOCATION
192	1	ALUM. SURF. CENTER AFT. OF SEEKER SECTION
193	2	CENTER OF CONTROL MODULES
89	3	EAST SIDE CONTROL MODULES
90	4	TOP CONTROL MODULES
194	5	WEST SIDE CONTROL MODULES
87	6	BOTTOM CONTROL MODULES
	7	SIDE OF EAST ACTUATOR
	8	TOP ACTUATOR
88	9	WEST ACTUATOR
	10	BOTTOM ACTUATOR
	11	EAST SIDE ACTUATOR ARM AT 10:00
	12	WEST SIDE ACTUATOR ARM AT 1:00
	13	
195	14	CENTER SURFACE GAS GENERATOR UNDER NUT
196	15	UNDER NUT
	16	TOP OUTSIDE SURFACE
	17	WEST OUTSIDE SURFACE
197	18	BOTTOM OUTSIDE SURFACE
	19	EAST OUTSIDE SURFACE

SIDEWINDER AIM -9H-2
TARGET DETECTING DEVICE MK 15 MOD 0

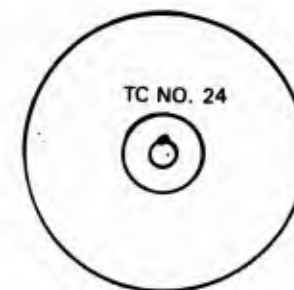
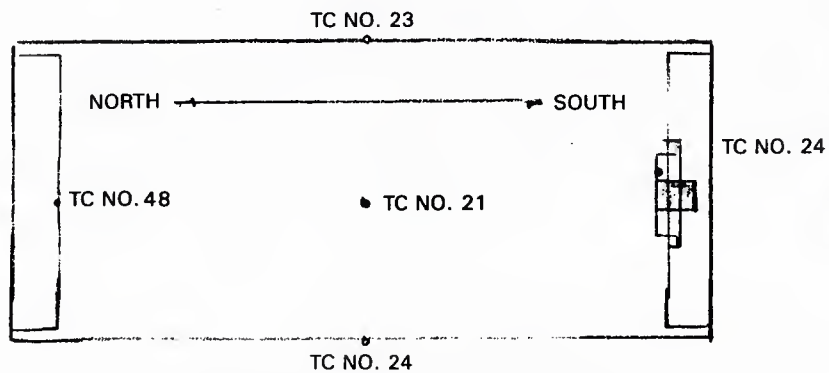
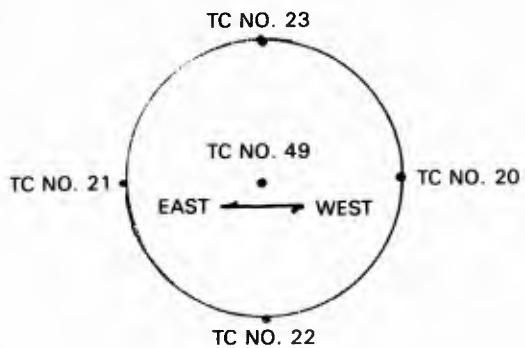

DATA CHANNEL	TC NO.	LOCATION
199	23	TOP OUTSIDE SURFACE (NON-METAL)
	20	WEST OUTSIDE SURFACE (NON-METAL)
	21	EAST OUTSIDE SURFACE (NON-METAL)
198	22	BOTTOM OUTSIDE SURFACE (NON-METAL)
91	24	AFT. CENTER ON METAL SURFACE
	49	FWD. CENTER ON METAL SURFACE

SIDEWINDER WARHEAD SECTION
MK 48 MOD 4



59

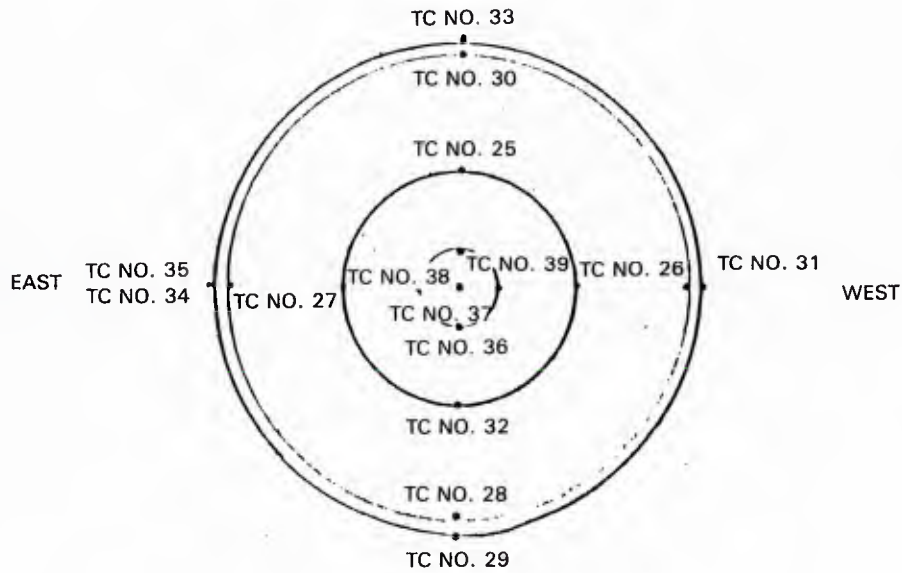

CHANNEL	TC NO.	LOCATION
82	25	TOP SURFACE OF GRAIN
81	26	WEST SURFACE OF GRAIN
	27	EAST SURFACE OF GRAIN
	28	BOTTOM INSIDE SURFACE OF CASE
	29	BOTTOM OUTSIDE SURFACE OF CASE
83	30	TOP INSIDE SURFACE OF CASE
84	31	WEST OUTSIDE SURFACE, CASE
	32	BOTTOM SURFACE GRAIN
85	33	TOP OUTSIDE SURFACE, CASE
	34	EAST INSIDE SURFACE, CASE
	35	EAST OUTSIDE SURFACE, CASE
	36	BOTTOM INSIDE SURFACE OF GRAIN
86	37	CENTER OF TUBE IN AIR
	38	EAST INSIDE SURFACE OF GRAIN
	39	WEST INSIDE SURFACE OF GRAIN

SIDEWINDER MOTOR SECTION

NORTH ← → SOUTH

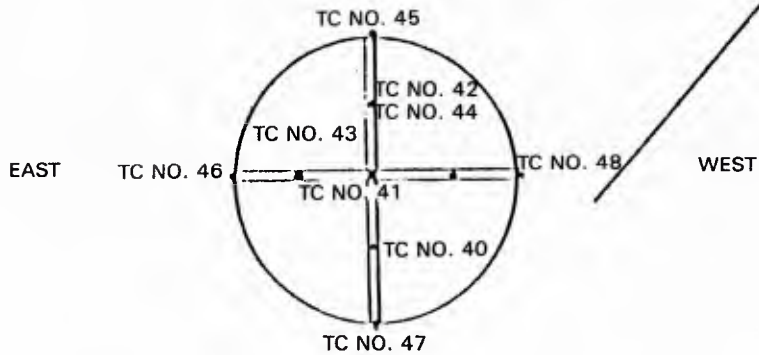
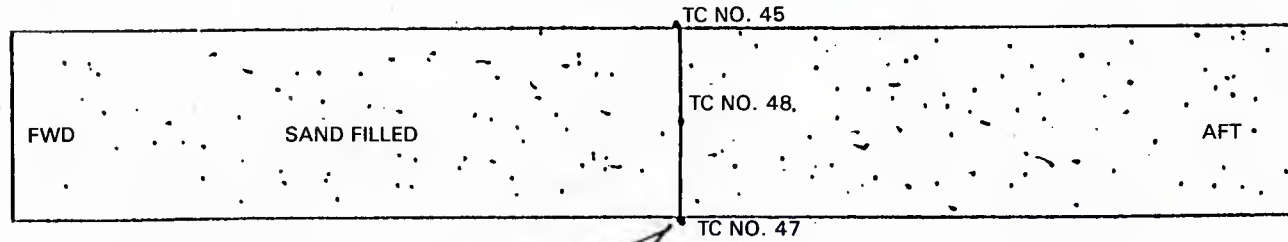

DATA CHANNEL	TC NO.	LOCATION
	40	INSIDE MOTOR 1 1/4 IN. FROM BOTOM
92	41	CENTER
	42	INSIDE MOTOR 1 1/4 IN. FROM TOP
	43	INSIDE MOTOR 1 1/4 IN. FROM EAST SIDE
96	48	WEST OUTSIDE SURFACE
	44	INSIDE MOTOR 1 1/4 IN. FROM WEST SIDE
94	45	TOP SURFACE
95	46	EAST OUTSIDE SURFACE
93	47	BOTTOM OUTSIDE SURFACE

INITIAL DISTRIBUTION

26 Naval Air Systems Command

AIR-00 (1)
AIR-04 (1)
AIR-05 (1)
AIR-05B (1)
AIR-310A (1)
AIR-320 (1)
AIR-330 (4)
AIR-340 (1)
AIR-42 (1)
AIR-5162 (1)
AIR-522 (1)
AIR-53033 (1)
AIR-5405 (1)
AIR-723 (2)
AIR-93A (1)
AIR-93D (1)
PDA-12 (1)
PMA-242 (1)
PMA-242A (1)
PMA-257 (1)
PMA-258 (1)
PMA-259 (1)

6 Chief of Naval Operations

OP-009D2 (1)
OP-092E2 (1)
OP-098 (1)
OP-098W (1)
OP-983 (1)
OP-987 (1)

3 Chief of Naval Research, Arlington

OCNR-10 (1)
OCNR-20 (1)
Technical Library (1)

1 Naval Facilities Engineering Command, Alexandria (NFAC-03)

34 Naval Sea Systems Command

SEA-00 (1)
SEA-003D5 (1)
SEA-06P (1)
SEA-09B312 (2)
SEA-311 (1)
SEA-3133 (1)
SEA-322 (1)
SEA-61C (1)
SEA-61R (1)
SEA-62C (1)
SEA-62C2, G. Mustin (2)
SEA-62D (1)
SEA-62P2 (1)
SEA-62Y (1)

NWC TP 5923, Part 1

- SEA-62Y1 (1)
- SEA-62Y23 (1)
- SEA-62Z (1)
- SEA-62Z1 (1)
- SEA-62Z2 (1)
- SEA-62Z3 (1)
- SEA-63Z (1)
- SEA-64 (1)
- SEA-90 (1)
- SEA-90E (1)
- SEA-90T (1)
- SEA-902 (1)
- SEA-94 (1)
- PMS-402 (1)
- PMS-405 (1)
- PMS-406 (1)
- PMS-407 (1)
- PMS-423, Code TN-11 (1)
- 3 Space and Naval Warfare Systems Command
 - SPAWAR-00 (1)
 - SPAWAR-09 (1)
 - PDW-107 (1)
- 1 Deputy Assistant Secretary of the Navy for Research and Advanced Technology
- 1 Commander in Chief, U.S. Pacific Fleet (Code 325)
- 1 Commander, Third Fleet, Pearl Harbor
- 1 Commander, Seventh Fleet, San Francisco
- 1 Fleet Analysis Center, Naval Weapons Station, Seal Beach, Corona (Code 862, GIDEP Office)
- 6 Joint Cruise Missile Project Office
 - JCM-00 (1)
 - JCM-02 (1)
 - JCM-04 (1)
 - JCM-06 (1)
 - JCM-A-00 (1)
 - JCM-G-00 (1)
- 2 Naval Academy, Annapolis (Director of Research)
- 2 Naval Air Test Center, Patuxent River (Central Library, Bldg. 405)
- 2 Naval Avionics Center, Indianapolis
 - R. D. Stone (1)
 - Technical Library (1)
- 1 Naval Ocean Systems Center, San Diego (Technical Library)
- 25 Naval Ordnance Station, Indian Head
 - Code 5A (1)
 - Code 5011C, A. P. Allen (1)
 - Code 5712A (1)
 - Code FS11C (1)
 - Code FS12A1 (1)
 - Code FS12A2 (1)
 - Code FS12A6 (1)
 - Code FS12B (1)
 - Code FS12D (1)
 - Code FS13 (1)
 - Code FS13A (1)
 - Code FS13C (1)
 - Code FS14 (1)
 - Code FS15A (1)
 - Code FS15B (1)
 - Code FS42 (1)
 - Code FS63 (1)
 - Code FS64 (1)
 - Code FS72 (1)

NWC TP 5923, Part 1

- Code QA (1)
- Code QA3 (1)
- Code TDT (1)
- J. Wiggin (1)
- Technical Library (2)
- 1 Naval Postgraduate School, Monterey (Technical Library)
- 2 Naval Research Laboratory
 - Code 2600, Technical Library (1)
 - Code 5804, R. Volin (1)
- 4 Naval Surface Weapons Center, Dahlgren
 - Code D (1)
 - Code T (1)
 - Code U42, G. W. Allison (1)
 - Technical Library (1)
- 7 Naval Surface Weapons Center, White Oak Laboratory, Silver Spring
 - Code E21
 - C. V. Vickers (1)
 - V. Yarow (1)
 - Code NO, French (1)
 - Code WE (2)
 - Code XWF, Parker (1)
 - Technical Library (1)
- 1 Naval Underwater Systems Center, Newport
- 1 Naval War College, Newport
- 2 Naval Weapons Evaluation Facility, Kirtland Air Force Base
 - Code 210H, G. V. Binns (1)
 - Code 70, L. R. Oliver (1)
- 1 Naval Weapons Handling Center, Colts Neck (Code 805, R. E. Seely)
- 2 Naval Weapons Quality Assurance Office, Washington Navy Yard
 - Director (1)
 - Technical Library (1)
- 3 Naval Weapons Station, Colts Neck
 - Code 70, C. P. Troutman (1)
 - Technical Library (2)
- 1 Naval Weapons Station, Concord (Technical Library)
- 5 Naval Weapons Station, Seal Beach
 - Code QE (1)
 - Code QESX (1)
 - Code QESX-3 (1)
 - Environmental Test Branch (1)
 - Technical Library (1)
- 2 Naval Weapons Station, Yorktown
 - Code 3032, Smith (1)
 - Technical Library (1)
- 7 Naval Weapons Support Center, Crane
 - Code 30331, Lawson (1)
 - Code QETE (1)
 - Code RD (1)
 - NAPEC, J. R. Stokinger (1)
 - S. Strong (2)
 - Technical Library (1)
- 8 Pacific Missile Test Center, Point Mugu
 - Code 1141, T. Elliott (1)
 - Code 1143, C. V. Ryden (1)
 - Code 1202, L. Matthews (1)
 - Code 2133, F. J. Brennan (1)
 - Code 2143, R. W. Villers (1)
 - Code 3322, E. P. Olsen (1)
 - Code 6862, Technical Library (1)
 - Code 7379, Sparrow Office (1)

NWC TP 5923, Part 1

- 3 Strategic Systems Program Office
 - SSPO-26 (1)
 - SSPO-43 (2)
- 1 Army Armament Research and Development Command, Dover (DRDAR-TSS)
- 1 Army Training & Doctrine Command, Fort Monroe (ATCD-T)
- 7 Aberdeen Proving Ground
 - AMSTE-TA
 - Goddard (1)
 - Peterson (1)
 - DRSTE-AD-M, H. Eggbert (3)
 - STEAP-MT-M, J. A. Feroli (1)
 - Technical Library (1)
- 4 Army Engineer Topographic Laboratories, Fort Belvoir
 - ETL-CS-EA (1)
 - ETL-CS-EC, T. Neidringhaus (2)
 - Technical Library (1)
- 2 Chemical Research and Development Center, Aberdeen Proving Ground
 - Research and Development Laboratory (1)
 - Warfare Laboratory (1)
- 3 Harry Diamond Laboratories, Adelphi
 - R. Smith (1)
 - Technical Director (1)
 - Technical Library (1)
- 2 Office Chief of Research and Development
 - Dr. Leo Alpert (1)
 - Technical Library (1)
- 15 Headquarters, U.S. Air Force
 - AF/CVB(S) (1)
 - AF/SA (1)
 - AF/SAG (1)
 - AF/RD (1)
 - AF/RDC (1)
 - AF/RDPS, Allen Eaffy (1)
 - AF/RST (1)
 - AF/XO (1)
 - AS/DASJL (1)
 - ASCC/MC (1)
 - CCN (1)
 - RDQF (1)
 - SAFAL (1)
 - XOORC (1)
 - XOORE (1)
- 1 Air Force Logistics Command, Wright-Patterson Air Force Base (Technical Library)
- 1 Strategic Air Command, Offutt Air Force Base (Technical Library)
- 1 Tactical Air Command, Langley Air Force Base (Technical Library)
- 1 Air Force Acquisition Logistics Division, Wright-Patterson Air Force Base (Technical Library)
- 10 Air Force Armament Division, Eglin Air Force Base
 - AFATL/102 (1)
 - AFATL/AW (1)
 - AFATL/DL (1)
 - AFATL/SD (1)
 - AFATL/SD2 (1)
 - AFATL/SD3 (1)
 - AFATL/SD4 (1)
 - AFATL/SD8 (1)
 - AFATL/SDL (1)
 - Technical Library (1)
- 2 Air Force Cambridge Research Laboratories, Hanscom Air Force Base
 - Code LKI, P. Tattleman (1)
 - Technical Library (1)

- 1 Air Force Intelligence Service, Bolling Air Force Base (AFIS/INTAW, Maj. R. Lecklider)
- 1 Air Force Office of Scientific Research
- 1 Air Force Rocket Propulsion Laboratory, Edwards Air Force Base
 - Dr. Trout (1)
 - RKMA, L. Meyer (1)
 - Technical Director (1)
 - Technical Library (1)
- 1 Air Force Wright Aeronautical Laboratories, Wright-Patterson Air Force Base
 - AFWAL/AA (1)
 - AFWAL/FI (1)
 - AFWAL/FIE (1)
 - Head, Research and Technology Division (1)
- 3 Environmental Technical Applications Center, Scott Air Force Base
 - O. E. Richards (1)
 - Technical Director (1)
 - Technical Library (1)
- 1 Nellis Air Force Base (Technical Library)
- 2 Ogden Air Materiel Area, Hill Air Force Base
 - Munitions Safety (1)
 - Technical Library (1)
- 2 Rome Air Development Center, Griffiss Air Force Base
 - Code RCRM (1)
 - Technical Library (1)
- 1 Sacramento Air Materiel Area, McClellan Air Force Base
- 1 Warner Robins Air Materiel Area, Robins Air Force Base (Technical Library)
- 3 Armament/Munitions Requirements and Development (AMRAD) Committee (2C330, Pentagon)
- 2 DLA Administrative Support Center (Defense Materiel Specifications and Standards Office)
 - J. Allen (1)
 - D. Moses (1)
- 2 Defense Technical Information Center
- 3 Department of Defense Explosives Safety Board, Alexandria
- 3 Deputy Under Secretary of Defense, Acquisition Management
 - Director, Materiel Acquisition Policy, J. A. Mattino, 3E 144 (1)
 - Deputy Director, Standardization and Support, Col. T. A. Musson, 2A318 (2)
- 2 Deputy Under Secretary of Defense, Research and Advanced Technology
 - Director, Engineering Technology (1)
 - R. Thorkildsen (1)
- 1 Director, Defense Test and Evaluation (Deputy Director, Test and Evaluation Resources, W. A. Richardson, 3D1043A)

U225338