

AD-A172 547 CHISEL PLOMS: SECTION 824 US ARMY CORPS OF ENGINEERS 1/1  
WILDLIFE RESOURCES M. (U) ARMY ENGINEER WATERWAYS  
EXPERIMENT STATION VICKSBURG MS ENVIR. T B DOERR  
UNCLASSIFIED JUL 86 WES/TR/EL-86-55 F/G 13/13 NL

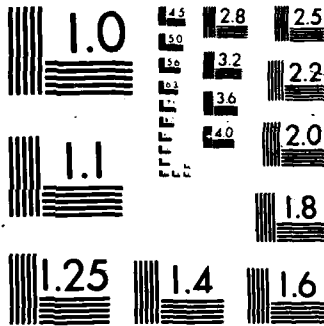





US Army Corps  
of Engineers

AD-A172 547

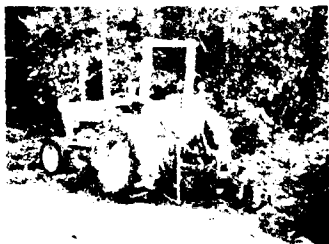

FILE COPY

# ENVIRONMENTAL IMPACT RESEARCH PROGRAM

12

TECHNICAL REPORT EL-86-55

## CHISEL PLOWS

Section 8.2.4, US ARMY CORPS OF ENGINEERS  
WILDLIFE RESOURCES MANAGEMENT MANUAL

by

Ted B. Doerr

Environmental Laboratory

DEPARTMENT OF THE ARMY  
Waterways Experiment Station, Corps of Engineers  
PO Box 631, Vicksburg, Mississippi 39180-0631

DTIC  
ELECTE  
OCT 3 1986  
S B D



July 1986

Final Report

Approved For Public Release. Distribution Unlimited

Prepared for DEPARTMENT OF THE ARMY  
US Army Corps of Engineers  
Washington, DC 20314-1000  
Under EIRP Work Unit 31631

86 10 01 170

Destroy this report when no longer needed. Do not return  
it to the originator.

The findings in this report are not to be construed as an official  
Department of the Army position unless so designated  
by other authorized documents.

The contents of this report are not to be used for  
advertising, publication, or promotional purposes.  
Citation of trade names does not constitute an  
official endorsement or approval of the use of  
such commercial products.

Unclassified

SECURITY CLASSIFICATION OF THIS PAGE

AD-A172547

REPORT DOCUMENTATION PAGE				Form Approved OMB No 0704-0188 Exp Date Jun 30, 1986	
1a REPORT SECURITY CLASSIFICATION <b>Unclassified</b>		1b RESTRICTIVE MARKINGS			
2a SECURITY CLASSIFICATION AUTHORITY		3 DISTRIBUTION/AVAILABILITY OF REPORT  <b>Approved for public release; distribution unlimited.</b>			
2b DECLASSIFICATION/DOWNGRADING SCHEDULE		5 MONITORING ORGANIZATION REPORT NUMBER(S)			
4 PERFORMING ORGANIZATION REPORT NUMBER(S)  <b>Technical Report EL-86-55</b>		7a NAME OF MONITORING ORGANIZATION			
6a NAME OF PERFORMING ORGANIZATION <b>USAEWES Environmental Laboratory</b>	6b OFFICE SYMBOL (if applicable)	7b ADDRESS (City, State, and ZIP Code)			
6c ADDRESS (City, State, and ZIP Code)  <b>PO Box 631 Vicksburg MS 39180-0631</b>		9 PROCUREMENT INSTRUMENT IDENTIFICATION NUMBER			
8a NAME OF FUNDING/SPONSORING ORGANIZATION <b>US Army Corps of Engineers</b>	8b OFFICE SYMBOL (if applicable)	10. SOURCE OF FUNDING NUMBERS		WORK UNIT ACCESSION NO	
8c ADDRESS (City, State, and ZIP Code)  <b>Washington, DC 20314-1000</b>		PROGRAM ELEMENT NO.	PROJECT NO	TASK NO	<b>EIRP 31631</b>
11 TITLE (Include Security Classification) <b>Chisel Plows: Section 8.2.4, US Army Corps of Engineers Wildlife Resources Management Manual</b>					
12 PERSONAL AUTHOR(S) <b>Doerr, Ted B.</b>					
13a. TYPE OF REPORT <b>Final report</b>	13b. TIME COVERED FROM _____ TO _____	14. DATE OF REPORT (Year, Month, Day) <b>July 1986</b>		15 PAGE COUNT <b>9</b>	
16 SUPPLEMENTARY NOTATION <b>Available from National Technical Information Service, 5285 Port Royal Road, Springfield, VA 22161.</b>					
17. COSATI CODES			18. SUBJECT TERMS (Continue on reverse if necessary and identify by block number)		
FIELD	GROUP	SUB-GROUP	Chisel plows Primary tillage		
			Equipment Site preparation		
			Seedbed preparation		
19 ABSTRACT (Continue on reverse if necessary and identify by block number)					
<p>→An equipment report on chisel plows is provided as Section 8.2.4 of the US Army Corps of Engineers Wildlife Resources Management Manual. The report is designed to assist the Corps District or project biologist with the selection and use of types of equipment and materials available for habitat development and manipulation. Topics covered include description, operation and maintenance, limitations, and availability.</p> <p>Chisel plows are simple implements of rugged construction used for primary tillage on sites too rough and rocky for effective disk plowing. They are also used to prepare an area for secondary tillage. Management objectives for using chisel plows are stated, and benefits to wildlife habitat are discussed. The design and assembly of equipment are described and illustrated, and general specifications are provided. Methods of operation are described, and maintenance and safety requirements are given. Appropriate cautions and limitations are discussed.</p>					
20 DISTRIBUTION/AVAILABILITY OF ABSTRACT <input checked="" type="checkbox"/> UNCLASSIFIED/UNLIMITED <input type="checkbox"/> SAME AS RPT <input type="checkbox"/> DTIC USERS			21 ABSTRACT SECURITY CLASSIFICATION <b>Unclassified</b>		
22a NAME OF RESPONSIBLE INDIVIDUAL			22b TELEPHONE (Include Area Code)	22c OFFICE SYMBOL	

## PREFACE

This work was sponsored by the Office, Chief of Engineers (OCE), US Army, as part of the Environmental Impact Research Program (EIRP), Work Unit 31631, entitled Management of Corps Lands for Wildlife Resource Improvement. The Technical Monitors for the study were Dr. John Bushman and Mr. Earl Eiker, OCE, and Mr. Dave Mathis, Water Resources Support Center.

This report was prepared by Mr. Ted B. Doerr, Range Science Department, Colorado State University, Fort Collins, Colo. Mr. Doerr was employed by the Environmental Laboratory (EL), US Army Engineer Waterways Experiment Station (WES), under an Intergovernmental Personnel Act contract with Colorado State University during the period this report was prepared. Mr. Chester O. Martin, Team Leader, Wildlife Resources Team, Wetlands and Terrestrial Habitat Group (WTHG), EL, was principal investigator for the work unit. Review and comments were provided by Mr. Martin, WES, and Mr. Larry E. Marcy, Texas A&M University.

The report was prepared under the general supervision of Dr. Hanley K. Smith, Chief, WTHG, EL; Dr. Conrad J. Kirby, Chief, Environmental Resources Division, EL; and Dr. John Harrison, Chief, EL. Dr. Roger T. Saucier, WES, was Program Manager, EIRP. The report was edited by Ms. Jessica S. Ruff of the WES Information Products Division (IPD). Drawings were prepared by Mr. John R. Harris, Scientific Illustrations Section, IPD, under the supervision of Mr. Aubrey W. Stephens, Jr.

COL Allen F. Grum, USA, was the previous Director of WES. COL Dwayne G. Lee, CE, is the present Commander and Director. Dr. Robert W. Whalin is Technical Director.

This report should be cited as follows:

Doerr, Ted B. 1986. "Chisel Plows: Section 8.2.4, US Army Corps of Engineers Wildlife Resources Management Manual," Technical Report EL-86-55, US Army Engineer Waterways Experiment Station, Vicksburg, Miss.

NOTE TO READER

This report is designated as Section 8.2.4 in Chapter 8 -- EQUIPMENT, Part 8.2 -- SITE AND SEEDBED PREPARATION EQUIPMENT, of the US ARMY CORPS OF ENGINEERS WILDLIFE RESOURCES MANAGEMENT MANUAL. Each section of the manual is published as a separate Technical Report but is designed for use as a unit of the manual. For best retrieval, this report should be filed according to section number within Chapter 8.



Approved	<input checked="" type="checkbox"/>
Reviewed	<input type="checkbox"/>
Checked	<input type="checkbox"/>
Dist	<input type="checkbox"/>
A-1	<input type="checkbox"/>

# CHISEL PLOWS

Section 8.2.4, US ARMY CORPS OF ENGINEERS  
WILDLIFE RESOURCES MANAGEMENT MANUAL

---

DESCRIPTION . . . . .	3	AVAILABILITY . . . . .	6
OPERATION AND MAINTENANCE . . . . .	5	LITERATURE CITED . . . . .	6
LIMITATIONS . . . . .	6		

---

Chisel plows are simple implements of rugged construction suited for primary tillage on sites too rough and rocky for effective disk plowing. They are also used to prepare an area for secondary tillage (i.e., disk harrowing, disk plowing, spring-tooth harrowing). Chisel plows reduce surface soil compaction, increase water infiltration, control herbaceous vegetation, and incorporate soil amendments. The rough, prepared seedbed is suited for broadcast seeding and protects the soil from wind and water erosion. The seedbed provides a variety of seed germination microsites, which enhances establishment of diverse vegetation communities. Chisel plows have been used throughout the United States for primary tillage on agricultural lands prior to disking or harrowing and can be used to prepare the soil for fall fallow. They are also used for seedbed preparation prior to seeding on mine reclamation projects.

## DESCRIPTION

Chisel plows are composed of curved cutting shanks mounted in several rows to a rigid frame set on wheels (Figs. 1 and 2). The shanks are mounted by spring clamps that allow each shank to move independently over rocks and other debris to reduce breakage. A variety of cutting tips (also called teeth or points) and shovels (sweeps) can be attached to each shank depending on tillage requirements (Fig. 2). Plow depth is controlled hydraulically by raising or lowering the frame height in relation to the support wheels. Larger chisel plows are composed of several units that can be folded upright for transport. Additional specifications are presented in Table 1.

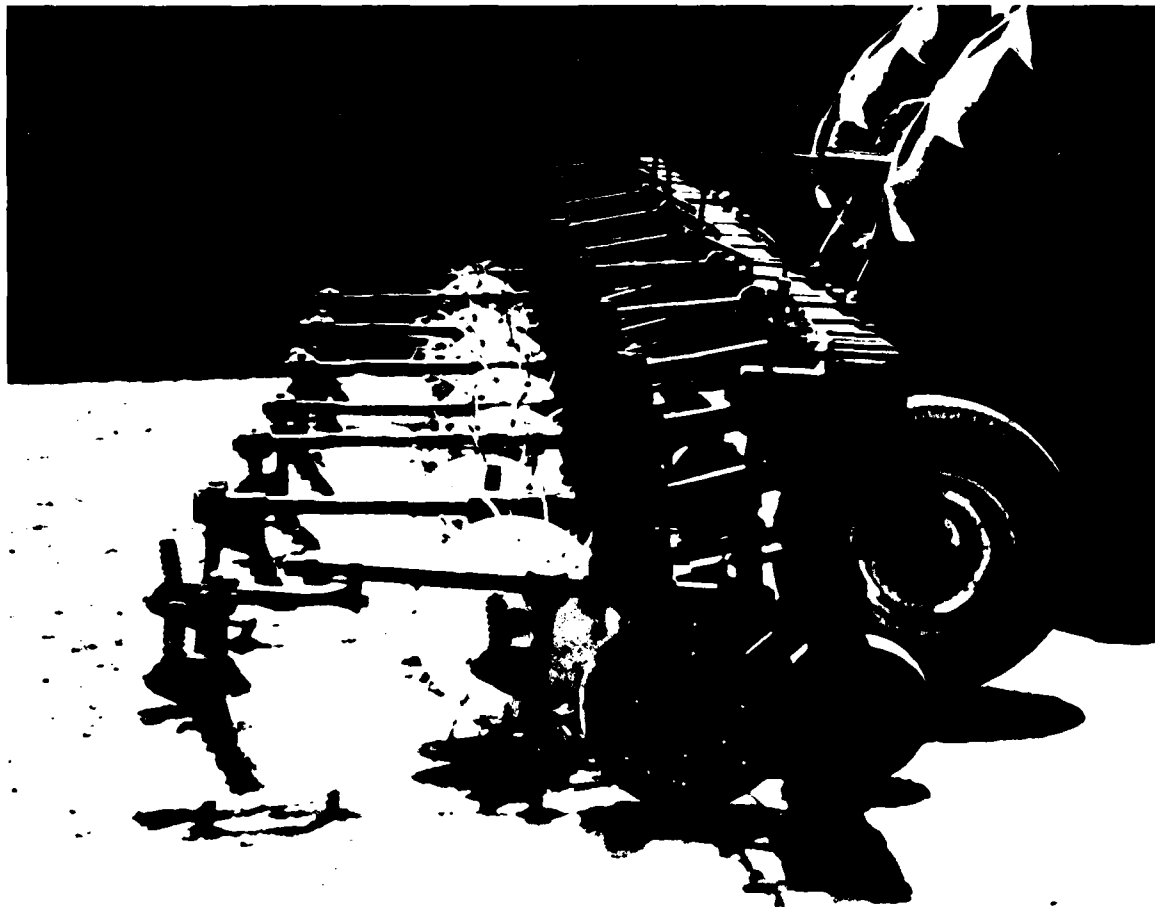

Figure 1. Two-row light-duty chisel plow mounted behind a mulch crimper and furrowing disk

Table 1. General specifications for chisel plows

<u>Feature</u>	<u>Specification</u>
Width	8.5 ft
Number of shank rows	1 to 4
Shank spacing	12-38 in.
Operation depth	6-20 in.
Power requirements	30-315 hp

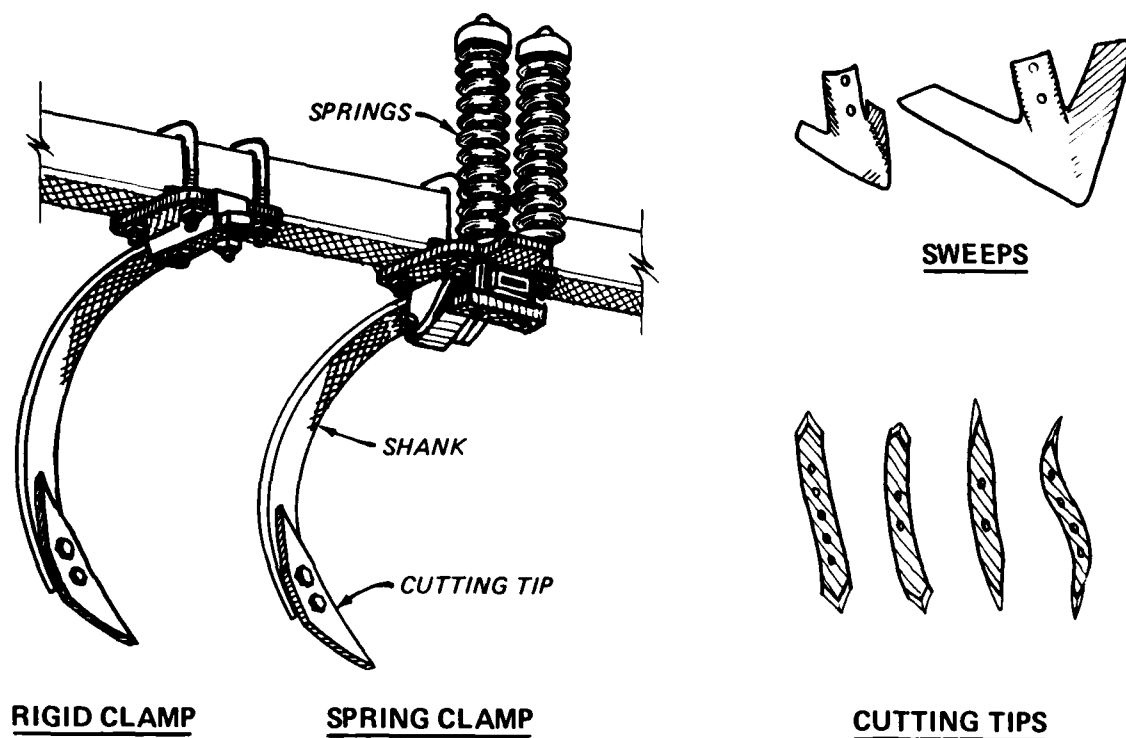

Figure 2. Detail of mounted shanks (left) and variation in sweeps, and cutting tips (right) for chisel plows.

There is considerable variation among chisel plows to meet a wide variety of needs. Small chisel plows have been modified to be disassembled for packing into inaccessible areas and to be pulled by animals (Larson 1980). Some large chisel plow frames are bolted together for ease of repair when damaged. Field cultivators are lightweight chisel plows designed for agricultural operations to disturb only selected rows while not harming crops. Shanks vary in size, flexibility, and curvature depending on the amount of clearance desired and depth of penetration. Cutting tips are also manufactured in a variety of designs.

#### OPERATION AND MAINTENANCE

Chisel plows are pulled behind a tractor at speeds of 3 to 4 mph. They should be pulled on the contour of slopes and perpendicular to the prevailing wind direction on level terrain. Narrow chisel tips create narrow furrows that collect water, reduce runoff velocity, and reduce wind erosion. The

furrows are shallow (about 6 in.) and last only a few weeks if subjected to intense rainfall. Broader shovel and sweep tips create more surface soil clods, mix soil and amendments more thoroughly, and destroy more roots than narrow chisel tips; however, they are more easily damaged by rocks and debris.

Chisel plows should be cleaned prior to storage. Hydraulic lines and fluid levels should be checked periodically, and shanks and tips should be checked for excess wear or breakage and replaced when necessary. When large areas are treated, vegetative debris needs to be cleared periodically from the shanks and frame while the equipment is stopped.

#### LIMITATIONS

Extremely rocky soils limit the use of chisel plows and increase breakage of shanks. Rocks brought to the surface during chisel plowing may impede secondary tillage (Larson 1980). Similarly, the rough seedbed will reduce the operational speed of drill seeding. Drill seed metering and seed placement will not be as accurate on chisel-plowed areas as on smoother disked soils. Chisel plows should not be operated on slopes greater than 30%.

#### AVAILABILITY

Chisel plows are available from most farm implement dealers and manufacturers.

#### LITERATURE CITED

Larson, J. E. 1980. Revegetation equipment catalogue. USDA For. Serv. Equipment Development Center, Catalogue No. 8042 2501. 198 pp.

END

1/156

DTIC